

OV9650 Color CMOS SXGA (1.3 MegaPixel) CameraChip™ Implementation Guide

Last Modified: 7 December 2004
Document Version: 1.1

Revision Number	Date	Revision
1.0	11/29/04	Initial Release
1.1	12/07/04	In Table 4-1 on page 21 , changed last six entries under column "Gain."

This document is provided "as is" with no warranties whatsoever, including any warranty of merchantability, non-infringement, fitness for any particular purpose, or any warranty otherwise arising out of any proposal, specification, or sample.

OmniVision Technologies, Inc. disclaims all liability, including liability for infringement of any proprietary rights, relating to the use of information in this document. No license, expressed or implied, by estoppel or otherwise, to any intellectual property rights is granted herein.

* Third-party brands, names, and trademarks are the property of their respective owners.

Note:

The information contained in this document is considered proprietary to OmniVision Technologies, Inc. This information may be distributed only to individuals or organizations authorized by OmniVision Technologies, Inc. to receive said information. Individuals and/or organizations are not allowed to re-distribute said information.

Table of Contents

Section 1, Introduction	6
1.1 Function Description	6
Section 2, Image Sensor Array	7
2.1 Resolution Formats	8
Section 3, Timing Generator	10
3.1 Array Control and Frame Generation	10
3.1.1 Frame Generation (SXGA, VGA, and lower resolutions)	10
3.2 Sync Signal Selection	10
3.3 Frame Rate Timing	11
3.3.1 Clock Prescaler (Timing Generator)	11
3.3.2 Dummy Pixel Adjustment (Output Formatter)	12
3.3.3 Dummy Line Adjustment	12
3.4 Exposure Control	12
3.4.1 Digital Exposure Control	12
3.5 Strobe Flash Control	19
3.6 RGB Raw Data Output Sequence	20
Section 4, Analog Processing Block	20
4.1 Gain Control	20
4.1.1 Manual Gain Control	20
4.1.2 Automatic Gain Control (AGC)	22
4.2 White Balance Control	23
4.2.1 Automatic White Balance Control	24
4.2.2 Manual White Balance	24
Section 5, Digital Signal Processor (DSP)	25
5.1 Gamma Control	25
5.1.1 Gamma Slope Calculation	26
5.2 Color Matrix	27
5.2.1 Color Matrix Control	27
5.3 Sharpness Control	30
5.4 Noise-Canceling	30
5.5 White Pixel Correction	30
5.6 Digital Black Level Calibration	30
5.7 Lens Shading Correction	31

Section 6, Output Formatter	33
6.1 Windowing	34
6.2 Data Formatting	35
6.2.1 ITU-656 Format Enable	36
6.2.2 Frame Rate Adjust	36
6.2.3 Output Data MSB/LSB Swap Enable	37
6.2.4 D[9:0] - PCLK Reference Edge	37
Section 7, Digital Video Port	38
Section 8, Special Image Effects	38
Section 9, Preview Mode to Still Image Capture Sequence	39
9.1 Exposure Time and Gain Calculation	40
Section 10, SCCB Interface	40
10.1 Control Functions	40
10.1.1 Register Reset	41
10.1.2 Standby Mode Enable	41
10.1.3 Tri-state Enable	41
10.2 Register Set	42
Section 11, Prototyping and Evaluation Modules	53
11.1 OV9650EAA Prototyping Module	53
11.2 OV9650ECX USB 2.0 Evaluation Module	53
Section 12, Lens selection	53
Section 13, OV9650 Bug List	53
Appendix A, Reference SCCB Settings	54

List of Figures

Figure 1-1	OV9650 Functional Block Diagram	6
Figure 3-1	Manual Exposure Frame Drop Timing Diagram	13
Figure 3-2	Desired Convergence	17
Figure 3-3	SXGA Strobe Flash Timing Diagram	19
Figure 3-4	VGA Strobe Flash Timing Diagram	19
Figure 3-5	QVGA Strobe Flash Timing Diagram	19
Figure 5-1	Gamma Curve	25
Figure 5-2	Lens Shading Correction	31
Figure 6-1	Example of Windowing	34
Figure 6-2	MSB/LSB Output Data Swap	37

Preliminary

List of Tables

Table 2-1	OV9650 Output Formats	7
Table 2-2	Resolution Register Settings	8
Table 3-1	Frame Rate, Pixel Clock Rate, and Input Clock Rate (CLKRC=0x81, 4X PLL)	11
Table 3-2	Banding Filter Value (Input Clock Frequency = 12 MHz, 4X PLL)	16
Table 3-3	AEC Convergence Limits	17
Table 3-4	AEC Options	18
Table 4-1	Total Gain to Control Bit Correlation	21
Table 4-2	AGC General Controls	22
Table 4-3	AGC Enable Bit	22
Table 4-4	AGC Convergence Limits	23
Table 4-5	AWB Red/Blue Balance Control	24
Table 5-1	Related Registers and Parameters	25
Table 5-2	Color Matrix Related Registers and Parameters	27
Table 5-3	Color Matrix Related Registers and Parameters	30
Table 5-4	Lens Shading Correction Registers and Parameters	32
Table 6-1	Output Formatting General Controls	33
Table 6-2	RGB:555 and RGB:565 Output Format Controls	33
Table 6-3	Windowing Control Registers	34
Table 6-4	Data Formatting	35
Table 7-1	Output Drive Current	38
Table 8-1	Special Image Effects	38
Table 10-1	SCCB Control Functions	40
Table 10-2	Device Control Register List	42

1 Introduction

This general application note is provided as a brief overview of the settings required for programming the OV9650 CAMERACHIP™. The Implementation Guide supplies the design engineer with quick-start tips for successful design solutions.

The [OV9650 Datasheet](#) provides complete information on the features, pin descriptions, and registers of the OV9650. The Implementation Guide is intended to complement the [OV9650 Datasheet](#) with considerations for PCB layout, register configurations, and timing parameters for rapid product design and deployment.

1.1 Function Description

Figure 1-1 shows the functional block diagram of the OV9650 image sensor. The OV9650 includes:

- Image Sensor Array (1300 x 1028 resolution)
- Timing Generator
- Analog Processing Block
- Digital Signal Processor (DSP)
- Output Formatter
- Digital Video Port
- SCCB Interface

Figure 1-1 OV9650 Functional Block Diagram

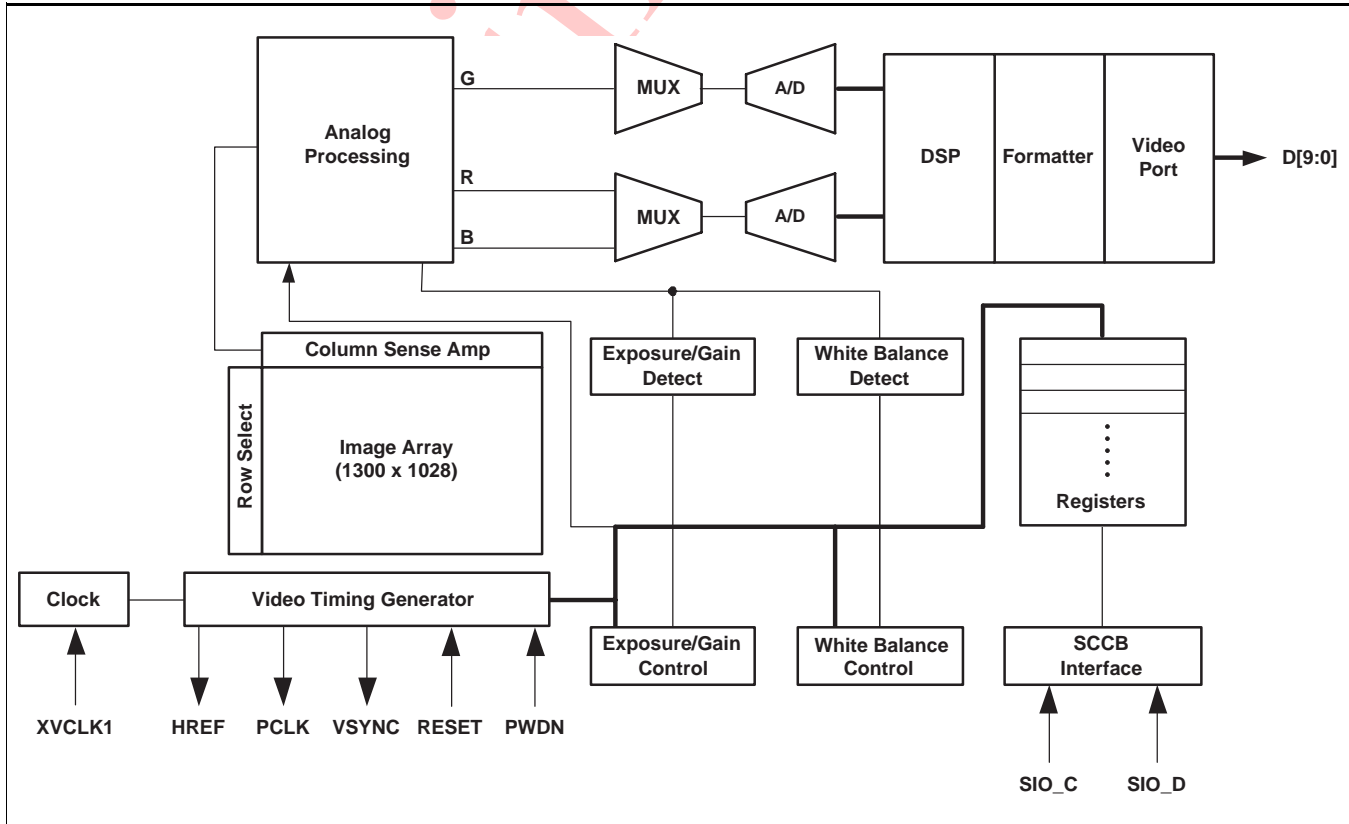

2 Image Sensor Array

The OV9650 CAMERACHIP has an active image array size of 1300 columns by 1028 rows (1,336,400 pixels).

The pixel cells themselves are identical, but have RGB color filters arranged in a line-alternating BG/GR Bayer Pattern. The final YUV/YCbCr image uses this filter pattern to interpolate each pixel's BG or GR color from the light striking the cell directly, as well as from the light striking the surrounding cells. The 'Raw RGB' image does not have any image processing.

Table 2-1 lists all OV9650 output formats.

Table 2-1. OV9650 Output Formats

Device	Format	Output	Register
OV9650	YUV/YCbCr	8 bits, 4:2:2 (Interpolated color)	COM7[2]=0 (0x12)
	GRB	8 bits, 4:2:2 (Interpolated color)	COM7[2]=1 (0x12), COM7[0]=0, COM15[4]=0 (0x40)
	RGB565	5-bit R, 6-bit G, 5-bit B	COM7[2]=1 (0x12), COM7[0] = 0, COM15[4]=1 (0x40), COM15[5]=0
	RGB555	5-bit R, 5-bit G, 5-bit B	COM7[2]=1 (0x12), COM7[0] = 0, COM15[4]=1 (0x40), COM15[5]=1
	Raw RGB	10/8 bits (Bayer filter color)	COM7[0]=1 (0x12), COM7[2] = 1

2.1 Resolution Formats

The OV9650 CAMERACHIP supports SXGA (1280x1024), VGA (640x480), CIF (352x288), QVGA (320x240), QCIF(176x144), QQVGA (160x120) and QQCIF (88x72). The different register settings for different resolution formats are listed in [Table 2-2](#).



Note: Contact your local OmniVision support engineer for OV9650 Reference SCCB settings. Sensor power-on default values are not the best settings for image quality.

Table 2-2. Resolution Register Settings (Sheet 1 of 2)

Resolution	Register Address	Value	Description (12 MHz Input Clock, 4X PLL)
SXGA	COM1 (0x04)	0x00	15 fps SXGA YUV mode
	COM3 (0x0C)	0x00	
	COM4 (0x0D)	0x00	
	CLKRC (0x11)	0x80	
	COM7 (0x12)	0x00	
	ADC (0x37)	0x81	
	ACOM (0x38)	0x93	
	OFON (0x39)	0x50	
VGA	COM1 (0x04)	0x00	30 fps VGA YUV mode
	COM3 (0x0C)	0x04	
	COM4 (0x0D)	0x80	
	CLKRC (0x11)	0x81	
	COM7 (0x12)	0x40	
	ADC (0x37)	0x91	
	ACOM (0x38)	0x12	
	OFON (0x39)	0x43	
QVGA	COM1 (0x04)	0x00	30 fps QVGA YUV mode
	COM3 (0x0C)	0x04	
	COM4 (0x0D)	0x80	
	CLKRC (0x11)	0x83	
	COM7 (0x12)	0x10	
	ADC (0x37)	0x91	
	ACOM (0x38)	0x12	
	OFON (0x39)	0x43	

Table 2-2. Resolution Register Settings (Sheet 2 of 2)

Resolution	Register Address	Value	Description (12 MHz Input Clock, 4X PLL)
QQVGA	COM1 (0x04)	0x24	30 fps QQVGA YUV mode
	COM3 (0x0C)	0x04	
	COM4 (0x0D)	0x80	
	CLKRC (0x11)	0x83	
	COM7 (0x12)	0x10	
	ADC (0x37)	0x91	
	ACOM (0x38)	0x12	
	OFON (0x39)	0x43	
CIF	COM1 (0x04)	0x00	30 fps CIF YUV mode
	COM3 (0x0C)	0x04	
	COM4 (0x0D)	0x80	
	CLKRC (0x11)	0x83	
	COM7 (0x12)	0x20	
	ADC (0x37)	0x91	
	ACOM (0x38)	0x12	
	OFON (0x39)	0x43	
QCIF	COM1 (0x04)	0x00	30 fps QCIF YUV mode
	COM3 (0x0C)	0x04	
	COM4 (0x0D)	0x80	
	CLKRC (0x11)	0x87	
	COM7 (0x12)	0x08	
	ADC (0x37)	0x91	
	ACOM (0x38)	0x12	
	OFON (0x39)	0x43	
QQCIF	COM1 (0x04)	0x24	30 fps QQCIF YUV mode
	COM3 (0x0C)	0x04	
	COM4 (0x0D)	0x80	
	CLKRC (0x11)	0x87	
	COM7 (0x12)	0x08	
	ADC (0x37)	0x91	
	ACOM (0x38)	0x12	
	OFON (0x39)	0x43	

3 Timing Generator

In general, the timing generator controls the following functions:

- [Array Control and Frame Generation](#) (SXGA, VGA, QVGA, QQVGA, CIF, QCIF and QQCIF outputs)
- Internal timing signal generation and distribution
- [Frame Rate Timing](#)
- [Exposure Control](#)
- External timing outputs (VSYNC, HREF/HSYNC, and PCLK)

3.1 Array Control and Frame Generation

3.1.1 Frame Generation (SXGA, VGA, and lower resolutions)

SXGA frame generation uses Progressive scanning of the array in which rows are sequentially read and transferred out to the APB. The 'Raw RGB' output preserves the Bayer Filter pattern, so odd rows follow the pattern (BG) and even rows follow the pattern (GR). Simple sub-sampling mode just skips every other two rows and every other two columns for VGA mode. The OV9650 has built-in VarioPixel™ technology to improve sub-sampled image resolution and reduce noise level. Down-scaling technology down-scales the output size. VGA, QVGA, QQVGA, CIF, QCIF, and QQCIF have the same view angle which cuts 6.25% of the vertical view and keeps the same horizontal view of SXGA.

3.2 Sync Signal Selection

The OV9650 CAMERACHIP supplies two output sync signals: VSYNC and HREF. The vertical sync (VSYNC) signal is output on pin D2. The horizontal reference signal (HREF) is output on pin E1. The HSYNC signal is available on pin E1 (shares with HREF) when register [COM10](#)[6] (0x15) value is set to "1".

The VSYNC and HSYNC signals are continuous. The HREF signal is only valid when there is active output data. If there is no output data, the HREF signal will remain at either high or low, depending on the polarity selection. The HSYNC/VSYNC/HREF/PCLK polarity selection is controlled by register [COM10](#)[0,1,3,4] (0x15), respectively. Usually, an application uses the rising edge of PCLK to capture data when HREF is high.

The OV9650 can encode horizontal and vertical sync information into data. Set register [COM1](#)[6] (0x04) high to enable the CCIR656 format.

Refer to the [OV9650 Datasheet](#) for detailed signal timing information.

3.3 Frame Rate Timing

The OV9650 offers three methods of frame rate adjustment:

- Clock Prescaler (Timing Generator)
- Dummy Pixel Adjustment (Output Formatter)
- Dummy Line Adjustment

3.3.1 Clock Prescaler (Timing Generator)

OV9650 divides the input clock by 2 first. Setting register `CLKRC[7]` (0x11) high turns on the internal clock doubler. Register `CLKRC[5:0]` is the internal clock pre-scaler. By programming register `CLKRC[5:0]` (0x11), the frame rate and pixel rate can be divided by 1, 2, 3, 4, ... 64. The internal clock frequency, $f_{\text{INT CLK}}$, can be expressed as follows:

$$f_{\text{INT CLK}} = f_{\text{CLK}} \times ((\text{CLKRC}[7] + 1) / 2) / (\text{CLKRC}[5:0] + 1)$$

$$t_{\text{INT CLK}} = t_{\text{CLK}} \times (\text{CLKRC}[5:0] + 1) / ((\text{CLKRC}[7] + 1) / 2)$$

Table 3-1 shows the maximum frame rate and pixel clock (PCLK) for the given input clock rate (XCLK1). RGB raw pixel clock rate is half of YUV mode for the same frame rate and resolution.

Table 3-1. Frame Rate, Pixel Clock Rate, and Input Clock Rate (CLKRC=0x81, 4X PLL)

Resolution/Mode	Maximum Frame Rate (fps)	XCLK1 (MHz)	PCLK (MHz)
SXGA/Raw RGB	15	12	24
SXGA/YUV	15	12 ^a	48
VGA/Raw RGB	30	12	12
VGA/YUV	30	12	24
QVGA/Raw RGB	60	12	6
QVGA/YUV	60	12	12
QQVGA/Raw RGB	60	12	3
QQVGA/YUV	60	12	6
CIF/Raw RGB	60	12	12
CIF/YUV	60	12	24
QCIF/Raw RGB	120	12	6
QCIF/YUV	120	12	12
QQCIF/Raw RGB	120	12	3
QQCIF/YUV	120	12	6

a. CLKRC=0x80

3.3.2 Dummy Pixel Adjustment (Output Formatter)

By inserting dummy pixels in each row's output, the frame rate can be changed while leaving the pixel rate unchanged (see Section 6.2.2).

3.3.3 Dummy Line Adjustment

By inserting dummy lines in each frame output, the frame rate can be changed while leaving the pixel rate unchanged (see Section 6.2.2).

3.4 Exposure Control

The OV9650 CAMERACHIP supports both automatic and manual exposure control modes. The exposure time is defined as the interval from the cell precharge to the end of the photo-induced current measurement and can be controlled manually or by using the AEC function. This exposure control uses a 'rolling' shutter as exposure time is set on a row-by-row basis rather than on a frame-by-frame basis.

Exposure Time interval is defined as follows (15 fps in SXGA mode):

$$t_{\text{EXPOSURE}} = 2 \times (1520 \times t_{\text{INT CLK}}) \times \text{AEC}[15:0] \quad \text{where AEC}[15:0] \text{ is defined as:}$$

$$\text{AEC}[15:0] = \{\text{MSB, LSB}\} = \{\text{AECHM}[5:0] (0xA1), \text{AECH}[7:0] (0x10), \text{COM1}[1:0] (0x04)\}$$

$$\text{Each bit in AEC}[15:0] = t_{\text{ROW interval}} = 2 \times (1520 \times t_{\text{INT CLK}})$$

Note that both the AEC and AGC functions are interactive so registers and functions may be common to both. Also, in general, the AEC is the primary control and will be adjusted before the AGC (the AGC acts to adjust and center the AEC).

The algorithm used for the electronic exposure control is based on average luminance of the full, center-quarter, or center-half image. Each frame has digitally-generated averages (YUV for YUV mode or RGB for RGB mode) which are used to set the exposure time. The exposure is optimized for a "normal" scene that assumes the subject is well lit relative to the background. In situations where the image is not well lit, the AEC white/black ratio may be adjusted to suit the needs of the application.

3.4.1 Digital Exposure Control

3.4.1.1 Manual Exposure Control Mode

The manual exposure control mode allows for the companion backend processor to control the OV9650 image exposure. The companion backend processor may write exposure values to CAMERACHIP register **AECHM**[5:0] (0xA1) (MSB), **AECH**[7:0] (0x10), and **COM1**[1:0] (0x04) (LSB) according to its corresponding Auto-Exposure Control (AEC) algorithm.

The minimum allowable exposure value is 1 line. Exposure modes of less than 1 line may be used in special cases. The LSB signifies the 1 line exposure time. The exposure value data is 16-bits in length.

If the exposure increment exceeds the Exposure Gap (SXGA - 15 lines max, VGA - 11 lines max, QVGA/QVGA - 3 lines max, CIF - 89 lines max, QCIF/QQCIF - 41 lines max), the next frame will appear over-exposed. Setting register COM9[1] (0x14) to a value of "1" will eliminate this over-exposure frame by eliminating the HREF signal output. This provision also allows for the companion backend processor to use the VSYNC as a frame data reset to eliminate the undesired frame by register COM9[2] (0x14). Refer to Figure 3-1 for details.

Figure 3-1 Manual Exposure Frame Drop Timing Diagram

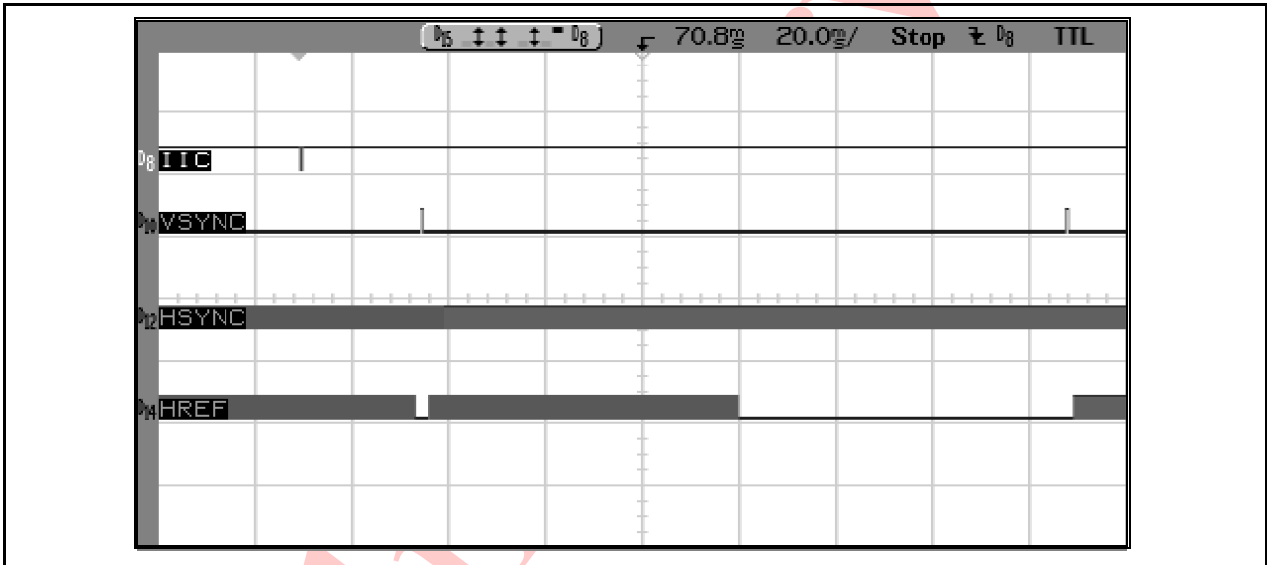

Rolling Horizontal Band Elimination in Manual Mode

The OV9650 supports a rolling shutter exposure mode and requires special exposure values when used in 50/60 Hz lighting conditions to eliminate rolling horizontal band (flicker). The minimum exposure value is 1/120 second for 60 Hz and 1/100 second for 50 Hz lighting conditions. The following steps outline how to calculate the proper exposure value at 50 Hz/60 Hz light conditions:

1. Calculate the CAMERACHIP Minimum Exposure Line (MEL):
 Line period is $T_{line} = K \times T_{pclk} = K/f_{pclk}$, while K is PCLK number in one line, T_{pclk} is PCLK period (sec) and f_{pclk} is PCLK frequency (Hz). $T_{pclk} = 1/f_{pclk}$. For example, for default 1280 x 1024 at 7.5 fps, K is 1520 x 2 in YUV mode and 1520 in RGB Raw Data mode. But YUV PCLK frequency is double that of RGB Raw Data mode with same T_{line} .
 For 60 Hz lighting: $MEL = (1/120)/T_{line} = 1/(120 \times K \times T_{pclk}) = f_{pclk}/(120 \times K)$
 For 50 Hz lighting: $MEL = (1/100)/T_{line} = 1/(100 \times K \times T_{pclk}) = f_{pclk}/(100 \times K)$



Note: For calculating MEL, use the line period of QCIF for QQCIF resolution. For QQVGA, use the line period of QVGA.

2. Set the CAMERACHIP Available Exposure Line (AEL):
Suppose N is integer, $N = 1, 2, 3, \dots$
Available exposure line are: $AEL = N \times MEL$ where AEL should be equal or less than the maximum exposure line limitation based on different resolutions.
3. Convert AEL to binary, and then send 2 LSBs hex number to register **COM1**[1:0] (0x04) and 8 MSBs hex number to register **AECH**[7:0] (0x10) and 6 MSBs to register **AECHM**[5:0] (0xA1).

Maximum Exposure Line Limitation

OV9650 maximum exposure line values are:

- SXGA - 1048 lines
Register setting: {**AECHM**[5:0] (0xA1) = 0x01, **AECH**[7:0] (0x10) = 0x06, **COM1**[1:0] (0x04) = 0x00}
- VGA - 498 lines
Register setting: {**AECHM**[5:0] (0xA1) = 0x00, **AECH**[7:0] (0x10) = 0x7C, **COM1**[1:0] (0x04) = 0x02}
- QVGA - 248 lines
Register setting: {**AECHM**[5:0] (0xA1) = 0x00, **AECH**[7:0] (0x10) = 0x3E, **COM1**[1:0] (0x04) = 0x00}
- QQVGA - 248 lines
Register setting: {**AECHM**[5:0] (0xA1) = 0x00, **AECH**[7:0] (0x10) = 0x3E, **COM1**[1:0] (0x04) = 0x00}
- CIF - 382 lines
Register setting: {**AECHM**[5:0] (0xA1) = 0x00, **AECH**[7:0] (0x10) = 0x5F, **COM1**[1:0] (0x04) = 0x02}
- QQCIF - 190 lines
Register setting: {**AECHM**[5:0] (0xA1) = 0x00, **AECH**[7:0] (0x10) = 0x2F, **COM1**[1:0] (0x04) = 0x02}
- QQCIF - 190 lines
Register setting: {**AECHM**[5:0] (0xA1) = 0x00, **AECH**[7:0] (0x10) = 0x2F, **COM1**[1:0] (0x04) = 0x02}

3.4.1.2 Automatic Exposure Control Mode (AEC)

The AEC function allows for the CAMERACHIP to adjust the exposure without external command or control. The registers **AECHM**[5:0] (0xA1), **AECH**[7:0] (0x10), and **COM1**[1:0] (0x04) are adjusted by the CAMERACHIP internal controls and cannot be overwritten by an external device.

Auto-Exposure Control Enable Bit

To enable the AEC function, set register **COM8**[0] (0x13) to "1". The AEC controls image luminance using registers **AEW** (0x24) and **AEB** (0x25). The register **AEW** (0x24) value indicates the high threshold value and register **AEB** (0x25) indicates the low threshold value. When the target image luminance average value (YAVG) is within the range specified by registers **AEW** (0x24) and **AEB** (0x25), the AEC keeps the image exposure. When YAVG, is greater than the value in register **AEW** (0x24), the AEC will decrease the image exposure. When YAVG is less than the value in register **AEB** (0x25), the AEC will increase the image exposure. Accordingly, the value in register **AEW** (0x24) should be greater than the value in register **AEB** (0x25). The gap between the **AEW** (0x24) and **AEB** (0x25) register values controls the image stability. The recommended values for register **AEW** (0x24) and **AEB** (0x25) are: **AEW** (0x24) = 0x74; **AEB** (0x25) = 0x68.

Rolling Horizontal Band Elimination in Auto Mode

OV9650 also provides rolling horizontal band eliminate function in auto exposure mode. A banding filter is employed to eliminate banding caused by 50/60 Hz lighting. To enable this function, set register [COM8\[5\]](#) (0x13) to high.

When the banding filter is enabled, the AEC will set the exposure time to a set of discrete values, among which the minimum value is called the Banding Filter Value. OV9650 has two options to set the Banding Filter Value. The first option is manual banding filter mode, which is enabled by setting register [COM11\[0\]](#) (0x3B) to high. In manual banding filter mode, the Banding Filter Value is specified by register [MBD\[7:0\]](#) (0x6A) and the companion backend processor can program this register according to the lighting frequency. The second option is auto banding mode, which is enabled by setting register [COM11\[0\]](#) (0x3B) to low. In auto banding mode, the Banding Filter Value is specified by register [BD50ST\[7:0\]](#) (0xA2) if register [COM17\[0\]](#) (0x42) is high, or by register [BD60ST\[7:0\]](#) (0xA3) if register [COM17\[0\]](#) (0x42) is low. The companion backend processor can set register [BD50ST\[7:0\]](#) (0xA2) and [BD60ST\[7:0\]](#) (0xA3) for 50 Hz and 60 Hz, respectively, and then, toggle register [COM17\[0\]](#) (0x42) to switch between 50 Hz and 60 Hz lighting frequency.

If the light is too strong, the minimum exposure time (equal to Banding Filter Value) to eliminate the banding may result in an over-exposed image. To avoid over-exposure, OV9650 has an option to allow the real exposure time to be less than the Banding Filter Value by setting register [COM9\[3\]](#) (0x14).

Banding Filter Value Calculation

The Banding Filter Value depends on the lighting frequency, frame rate, and maximum exposure. The equations are shown below. Frame rate can be derived from [Table 3-1](#). Refer to section [Maximum Exposure Line Limitation](#) for the maximum exposure.

$$\text{Banding Filter Value} = \frac{\text{Frame Rate} \times \text{Maximum Exposure Line}}{120} \quad \text{for 60 Hz}$$

$$\text{Banding Filter Value} = \frac{\text{Frame Rate} \times \text{Maximum Exposure Line}}{100} \quad \text{for 50 Hz}$$

Note:

1. Refer to ["Maximum Exposure Line Limitation"](#) on page 14 for details of maximum exposure line.
2. If the frame rate is adjusted by inserting dummy lines, the Maximum Exposure Line is equal to the original value plus the number of dummy lines. Consequently, the Banding Filter Value does not change with the number of dummy line.
3. If the frame rate is adjusted by inserting dummy pixels, the Maximum Exposure Line does not change. Consequently, the Banding Filter Value will change with the number of dummy pixels. In the case where the OV9650 works at a system clock frequency other than 24 MHz or 48 MHz, it is very convenient to adjust the frame rate by adding some dummy pixels (setting register [EXHCH](#) (0x2A) and [EXHCL](#) (0x2B)) while keep the Banding Filter Value the same with that using a 24 MHz or 48MHz system clock.

Table 3-2 shows the Banding Filter Values for 50 Hz and 60 Hz light frequency conditions. Contact your local OmniVision FAE to get the appropriate setting for your application.

Table 3-2. Banding Filter Value (Input Clock Frequency = 12 MHz, 4X PLL)

Resolution	Clock Pre-Scalar (CLKRC (0x11))	Format	Frame Rate (fps)	Banding Filter Value	
				50 Hz (BD50ST (0xA2))	60 Hz (BD60ST (0xA3))
SXGA	0x81	YUV	7.5	0x4E	0x41
		Raw	15	0x9D	0x83
VGA	0x83	YUV/Raw	15	0x4B	0x3E
QVGA	0x83	YUV/Raw	30	0x4B	0x3E
QQVGA	0x83	YUV/Raw	30	0x4B	0x3E
CIF	0x83	YUV/Raw	30	0x73	0x60
QCIF	0x87	YUV/Raw	30	0x39	0x30
QQCIF	0x87	YUV/Raw	30	0x39	0x30

With Banding Filter Disabled

The AEC function supports both normal and fast speed selections in order to bring the image exposure into the range set by the values in registers **AEW** (0x24) and **AEB** (0x25). AEC set to normal mode will allow for single-step increase or decrease in the image exposure to maintain the specified range. AEC set to fast mode will provide for an approximate ten-step increase or decrease in the image exposure to maintain the specified range. A value of "0" in register **COM8[7]** (0x13) will result in normal speed operation and a "1" will result in fast speed operation.

In fast mode, register **VPT** (0x26) sets the AEC control zone and register **COM8[6]** (0x13) sets the step size. When **COM8[6]=1**, the exposure time will decrease by half if the target image YAVG is greater than **VPT[7:4]** (0x26) × 16 and the exposure time will double if YAVG is less than **VPT[3:0]** (0x26) × 16. When **COM8[6]=0**, the exposure time will increase/decrease by 1/16th.

AEC Convergence Limits

Table 3-3 lists the registers used for setting AEC convergence limits.

Table 3-3. AEC Convergence Limits

Function	Register	Address
Control Zone – Upper Limit high nibble	VPT[7:4]	0x26
Control Zone – Lower Limit high nibble	VPT[3:0]	0x26
Stable Operating Region – Upper Limit	AEW[7:0]	0x24
Stable Operating Region – Lower Limit	AEB[7:0]	0x25
Step Size Limit	COM8[6]	0x13

As shown in Figure 3-2, the AEC/AGC convergence uses two regions, the inner stable operating region and the outer Control Zone, which defines the convergence step size change as follows:

- Outside Control Zone
Exposure time increase: $2 \times (\text{AEC}[15:0])$
Exposure time decrease: $(\text{AEC}[15:0]) / 2$
- Inside Control Zone
Exposure time increase: $(\text{AEC}[15:0]) / 16$
Exposure time decrease: $(\text{AEC}[15:0]) / 16$

Once the current value is inside the stable operating region, the AEC/AGC value has converged.

Figure 3-2 Desired Convergence

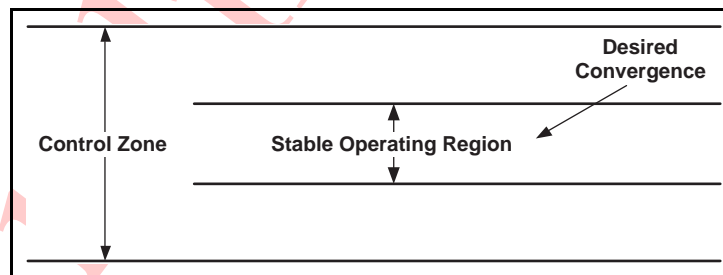

Control Zone Upper Limit: {VPT[7:4] (0x26) (MSB), 4'b0000 (LSB)}

Control Zone Lower Limit: {VPT[3:0] (0x26) (MSB), 4'b0000 (LSB)}

Stable Operating Region Upper Limit: AEW[7:0] (0x24)

Stable Operating Region Lower Limit: AEB[7:0] (0x25)

AEC Options

Table 3-4 shows lists the registers used for various AEC options.

Table 3-4. AEC Options

Function	Register	Address	Description
Center-Based Reference Area Enable	COM11[4:3]	0x3B	00: Full 01: Center-half 10: Center-quarter 11: Not allowed
Banding Filter Enable	COM8[5]	0x13	Banding filter enable "1"
Manual Banding Filter Enable	COM11[0]	0x3B	High enable
Manual Banding Filter Value	MBD[7:0]	0x6A	Minimum banding filter exposure time
Auto Banding Filter Enable	COM11[0]	0x3B	COM11[0]=0
Auto Banding Filter Value	BD50ST[7:0] BD60ST[7:0]	0xA2 0xA3	Minimum banding filter exposure time
Auto Banding Filter Value Selection	COM17[0]	0x42	0: Select BD60ST[7:0] (0xA3) as Auto Banding Filter Value 1: Select BD50ST[7:0] (0xA2) as Auto Banding Filter Value
Banding Filter - Avoid Over-Exposure	COM9[3]	0x14	0: Exposure time CANNOT be less than Banding Filter Value 1: Exposure time CAN be less than Banding Filter Value

Center-Based Reference Area Enable

Enabling this option changes the AEC/AGC exposure reference from the full array to the center-quarter, or center-half of the array.

3.5 Strobe Flash Control

To achieve the best image quality possible in low light conditions, the use of a strobe flash is recommended. The OV9650 supports rolling shutter exposure mode.

To avoid the need for a mechanical shutter, the OV9650 should be set to rolling shutter mode. When the rolling shutter mode is enabled and the image requires strobe flash illumination, the strobe timing must be limited. Timing diagrams for strobe flash timing are shown in Figure 3-4 and Figure 3-5.

Figure 3-3 SXGA Strobe Flash Timing Diagram

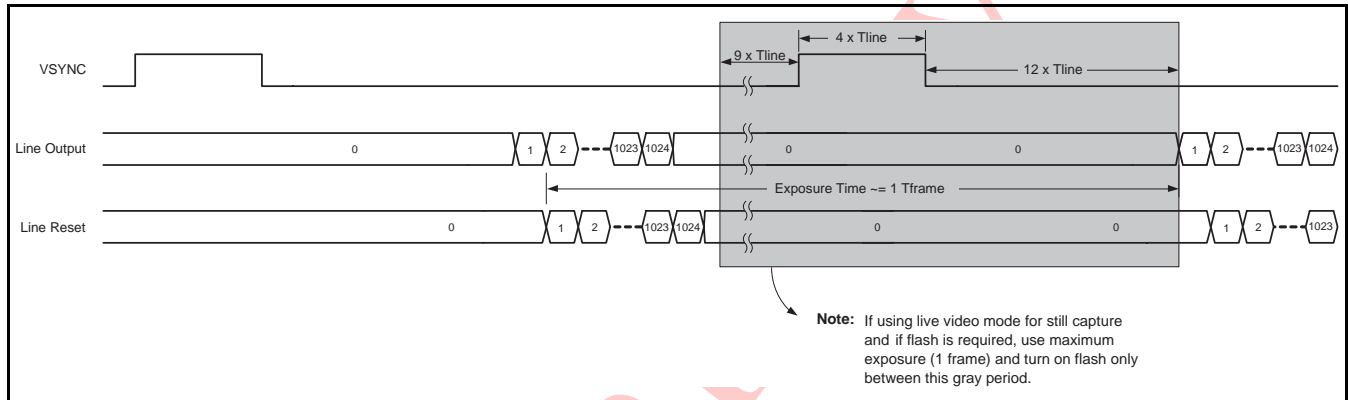

Figure 3-4 VGA Strobe Flash Timing Diagram

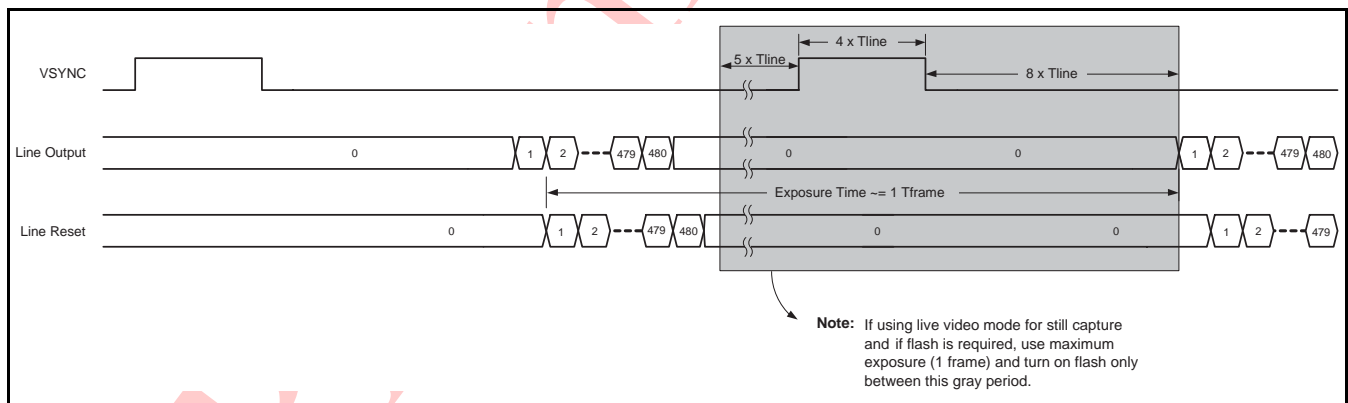
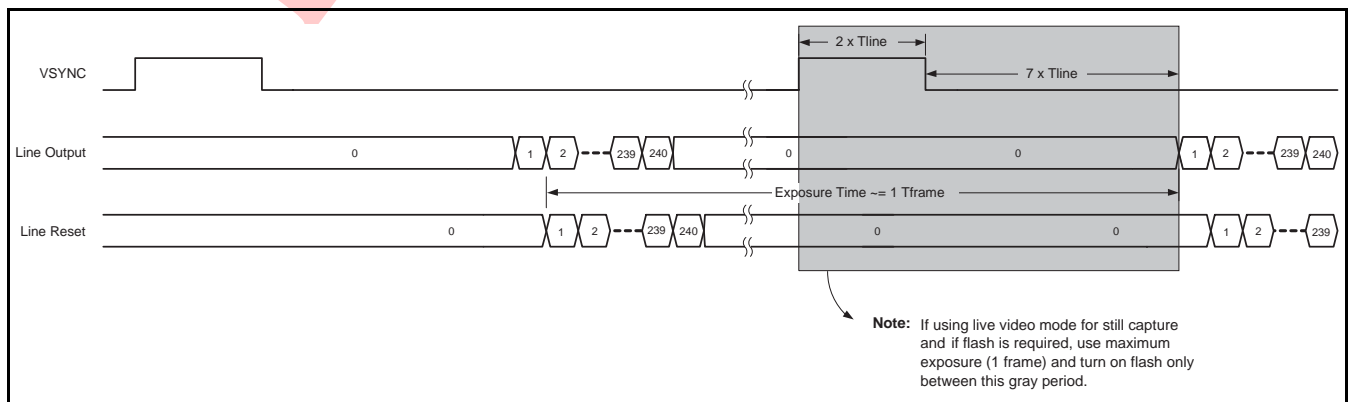

Figure 3-5 QVGA Strobe Flash Timing Diagram



3.6 RGB Raw Data Output Sequence

Review the [OV9650 Datasheet](#) for complete details regarding the RGB raw data output. Register [COM10\[4\]](#) (0x15) determines when the data is valid. Setting register [COM10\[4\]](#) (0x15) to "1" indicates the data is updated at the rising edge and valid at the falling edge of PCLK. Setting register [COM10\[4\]](#) (0x15) to "0" indicates the data is updated at the falling edge and valid at the rising edge of PCLK. The data receiver should latch data when data is valid, with either the rising or falling edge of PCLK, depending on register [COM10\[4\]](#) (0x15). Depending on this polarity selection, if the HREF signal is high, the data is valid. If the HREF signal is low, the data is not valid. HREF polarity can also be changed by setting register [COM10\[3\]](#) (0x15).

When using the HSYNC signal, adjust registers [EXHCH](#) (0x2A), [HSYST](#) (0x30), and [HSYEN](#) (0x31) to adjust the HSYNC signal rising and falling edges to obtain valid data. To obtain the HSYNC and HREF width, set registers [HSTART](#) (0x17) and [HSTOP](#) (0x18) or [EXHCH](#) (0x2A), [HSYST](#) (0x30), and [HSYEN](#) (0x31), respectively.

4 Analog Processing Block

This block performs all analog image functions including Automatic Gain Control (AGC), Automatic White Balance (AWB), and other image manipulation functions

4.1 Gain Control

The OV9650 CAMERACHIP provides support for both AGC and manual gain control modes.

4.1.1 Manual Gain Control

The manual gain control mode allows for the companion backend processor to control the OV9650 gain value. The companion backend processor may write gain control values to the CAMERACHIP RGB raw data register [GAIN\[7:0\]](#) (0x00) according to its corresponding AGC algorithm. The gain value is shown in [Table 4-1](#).

Table 4-1. Total Gain to Control Bit Correlation

Registers VREF[7:6] (0x03), GAIN[7:0] (0x00)	Gain	dB
00 00000000	1	0
00 00000001	$1 + 1/16$.375
00 00000010	$1 + 2/16$.75
00 00000011	$1 + 3/16$	1.125
00 00000100	$1 + 4/16$	1.5
00 00000101	$1 + 5/16$	1.875
00 00000110	$1 + 6/16$	2.25
00 00000111	$1 + 7/16$	2.625
00 00001000	$1 + 8/16$	3
00 00001001	$1 + 9/16$	3.375
00 00001010	$1 + 10/16$	3.75
00 00001011	$1 + 11/16$	4.125
00 00001100	$1 + 12/16$	4.5
00 00001101	$1 + 13/16$	4.875
00 00001110	$1 + 14/16$	5.25
00 00001111	$1 + 15/16$	5.625
00 00010000	$2 \times (1 + 0/16)$	6
00 00110000	$4 \times (1 + 0/16)$	12
00 01110000	$8 \times (1 + 0/16)$	18
00 11110000	$16 \times (1 + 0/16)$	24
01 11110000	$32 \times (1 + 0/16)$	30
11 11110000	$64 \times (1 + 0/16)$	36
11 11111111	$64 \times (1 + 15/16)$	~42

Note: To achieve the best image quality, using "maximum" exposure and "minimum" gain for the highest S/N ratio is recommended. When operating in low-light condition, use the strobe flash.

4.1.2 Automatic Gain Control (AGC)

The AGC function allows the CAMERACHIP to adjust image luminance and target level gain without external command or control. Register setting **COM8[2]** (0x13) enables AGC. The target level control registers are **AEW** (0x24) and **AEB** (0x25). Refer to [Section 3.4.1.2](#) for additional details regarding the target level controls. When operating in fast AEC/AGC mode, use register **VPT[7:0]** (0x26) to set the conditions for fast AGC. [Table 4-2](#) shows the general controls for the AGC.

Table 4-2. AGC General Controls

Function	Register	Address
AGC Enable	COM8[2]	0x13
Gain Setting	VREF[7:6] GAIN[7:0]	0x03 0x00
Gain Ceiling Select	COM9[6:4] 000: 2x 001: 4x 010: 8x 011: 16x 100: 32x 101: 64x 110: 128x 111: 128x	0x14

The analog pixel data first arrives at the AGC amplifier which can be automatically controlled by the AGC circuit or manually programmed by the user (see [Table 4-3](#)). In both cases, the gain control is active but when AGC is disabled, the gain setting is generated by the user and not updated by the AGC circuit.

Table 4-3. AGC Enable Bit

COM8[2] (0x13)	AGC Status	VREF[7:6] (0x03), GAIN[7:0] (0x00)
1	Enabled	Controlled by AGC
0	Disabled	Controlled by user

The AGC operation is identical to the AEC (see [Section 3.4.1.2](#)). [Table 4-4](#) lists the registers used to set the AGC convergence limits.

Table 4-4. AGC Convergence Limits

Function	Register	Address
Control Zone – Upper Limit high nibble	VPT[7:4]	0x26
Control Zone – Lower Limit high nibble	VPT[3:0]	0x26
Stable Operating Region – Upper Limit	AEW[7:0]	0x24
Stable Operating Region – Lower Limit	AEB[7:0]	0x25
Step Size Limit	COM8[6]	0x13

4.1.2.1 Center-Based Reference Area Enable

Enabling this option changes the AEC/AGC exposure reference from the whole image to the center-quarter, or center-half of the array (set in the AEC section - see [Section 3.4.1.2](#)).

4.2 White Balance Control

The OV9650 CAMERACHIP supports auto/manual white balance control. After the initial pixel level adjustment, the Red and Blue channel gains are optimized to the Green channel to set the white balance. This white balance is either automatically-controlled by the AWB circuit or manually-controlled by the user. The following describes these AWB modes:

- Full user control – RED/BLUE channels are set manually
- Normal AWB control – RED/BLUE channels are under AWB control based on R/G/B average values
- Advanced AWB control – RED/BLUE channels are under AWB control based on color temperature

Register [COM8\[1\]](#) (0x13) enables the AWB function. If this bit is set low, the user can manually control red and blue gain. If this bit is set to high, the red and blue gain is controlled by the sensor's internal AWB algorithm.

4.2.1 Automatic White Balance Control

In general, the white balance is done by adjusting the Red/Blue gain to match the Green channel.

The Red/Blue data is first amplified by a fixed pre-gain and then sent to the two (Red and Blue) AWB-controlled amplifiers (see [Table 4-5](#)).

Table 4-5. AWB Red/Blue Balance Control

Function	Register	Address
Blue Channel Preamplifier Gain Setting	HV[7:6]	0x69
Red Channel Preamplifier Gain Setting	HV[5:4]	0x69
Red Channel Gain Setting	RED[7:0]	0x02
Blue Channel Gain Setting	BLUE[7:0]	0x01

Contact your local OmniVision FAE for advanced AWB settings.

4.2.2 Manual White Balance

In manual mode, the companion backend processor can control OV9650 internal Red and Blue register values to achieve white balance. These registers are **BLUE** (0x01) and **RED** (0x02) and are defined as follows:

- Blue Gain: **BLUE**[7:0] (0x01)
- Red Gain: **RED**[7:0] (0x02)

$$\text{Gain} = [40 + ([7] \times 80 + [6] \times 47 + [5] \times 25 + [4] \times 13 + [3] \times 7 + [2] \times 4 + [1] \times 2 + [0] \times 1)] / 120$$

Blue and Red pre-gain are controlled by register **HV**[7:6] (0x69) and **HV**[5:4], respectively. The pre-gain is defined below:

- Blue Pre-Gain = $1 + [7] \times 0.50 + [6] \times 0.25$
- Red Pre-Gain = $1 + [5] \times 0.50 + [4] \times 0.25$

5 Digital Signal Processor (DSP)

The following subsections describe the controls for gamma, color matrix, and sharpness.

5.1 Gamma Control

The OV9650 gamma curve is composed of approximately 16 linear lines as shown in Figure 5-1 and Table 5-1.

Figure 5-1 Gamma Curve

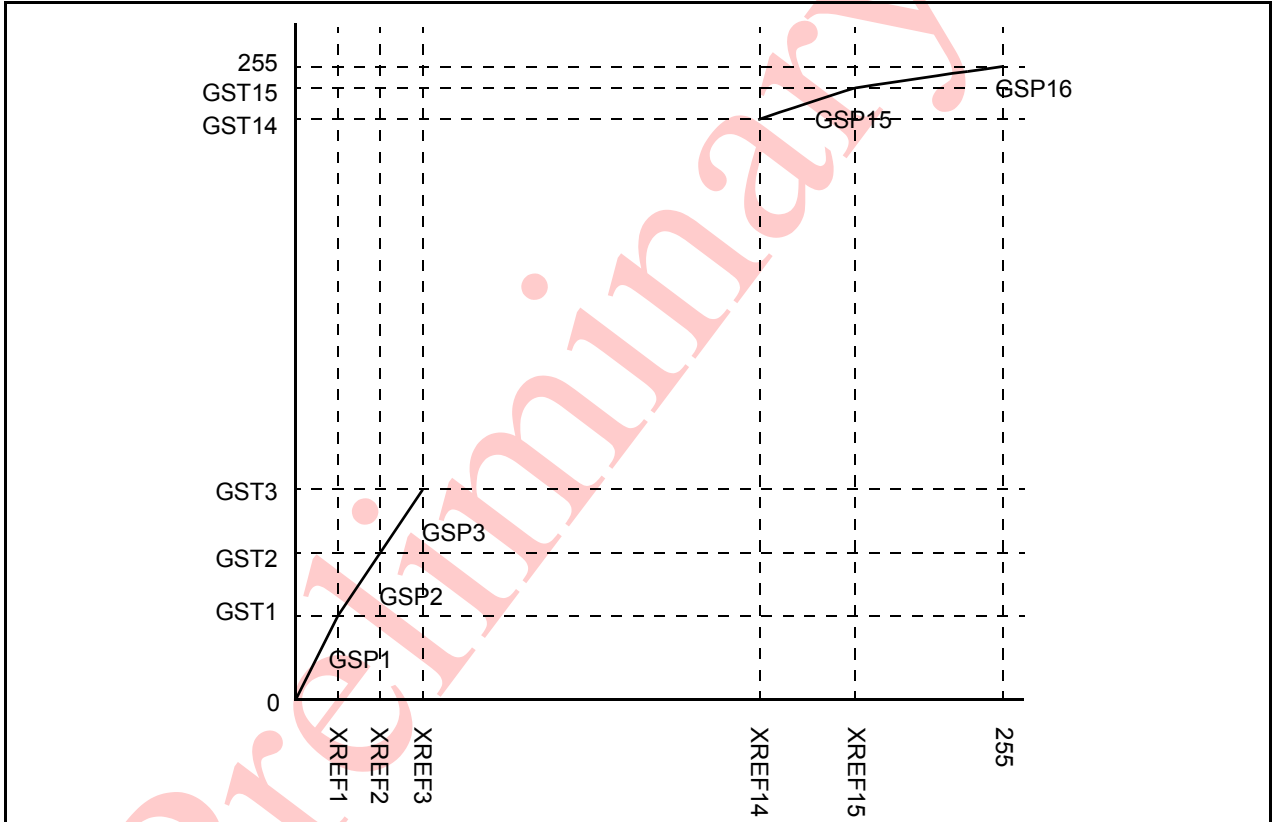

Table 5-1. Related Registers and Parameters (Sheet 1 of 2)

Gamma Start Point		Gamma Slope		Horizontal Reference	
Name	Register	Name	Register	Name	Value
		GSP1	0x6C	XREF1	4
GST1	0x7C	GSP2	0x6D	XREF2	8
GST2	0x7D	GSP3	0x6E	XREF3	16
GST3	0x7E	GSP4	0x6F	XREF4	32
GST4	0x7F	GSP5	0x70	XREF5	40
GST5	0x80	GSP6	0x71	XREF6	48
GST6	0x81	GSP7	0x72	XREF7	56

Table 5-1. Related Registers and Parameters (Sheet 2 of 2)

Gamma Start Point		Gamma Slope		Horizontal Reference	
Name	Register	Name	Register	Name	Value
GST7	0x82	GSP8	0x73	XREF8	64
GST8	0x83	GSP9	0x74	XREF9	72
GST9	0x84	GSP10	0x75	XREF10	80
GST10	0x85	GSP11	0x76	XREF11	96
GST11	0x86	GSP12	0x77	XREF12	112
GST12	0x87	GSP13	0x78	XREF13	144
GST13	0x88	GSP14	0x79	XREF14	176
GST14	0x89	GSP15	0x7A	XREF15	208
GST15	0x8A	GSP16	0x7B		

5.1.1 Gamma Slope Calculation

The Gamma Slope is determined by following equation:

$$\text{Gamma Slope}(i) = \frac{\text{GST}(i) - \text{GST}(i-1)}{\text{XREF}(i) - \text{XREF}(i-1)}$$



Note: GST(0) = 0, GST(16) = 255, XREF(0) = 0, XREF(16) = 255.

To normalize the real number (Gamma Slope) to an 8-bit decimal value, the OV9650 applies 64 as a normalize factor as shown below:

$$\text{GSP}(i) = \text{Gamma Slope}(i) \times 64 = \frac{\text{GST}(i) - \text{GST}(i-1)}{\text{XREF}(i) - \text{XREF}(i-1)} \times 64$$



Note: Gamma Start Point and Slope should be matched; otherwise, there will be discontinuous points in the Gamma curve.

5.2 Color Matrix

The color matrix is used to eliminate the cross talk induced by the micro-lens and color filter process. It also compensates for lighting and temperature effects. It also can be implemented for hue, color saturation, color space conversion from RGB to YUV or RGB to YCbCr.

5.2.1 Color Matrix Control

OV9650 has a 3x3 color matrix circuit inside. This color matrix performs the color correction and the RGB to YUV/YCbCr conversion. Also, because of the Matrix linear algebra characteristic, it can also do color gain and hue control as shown below:

$$[YUV] = [\text{Gain Matrix}] \times [\text{Hue Matrix}] \times [\text{RGB to YUV/YCbCr Matrix}] \times [\text{Color correction}] \times [\text{RGB}]$$

$$[YUV] = [\text{Combined Matrix}] [\text{RGB}]$$

Table 5-2. Color Matrix Related Registers and Parameters

Name	Register	Address
MTX1	MTX1	0x4F
MTX2	MTX2	0x50
MTX3	MTX3	0x51
MTX4	MTX4	0x52
MTX5	MTX5	0x53
MTX6	MTX6	0x54
MTX7	MTX7	0x55
MTX8	MTX8	0x56
MTX9	MTX9	0x57
SIGN	MTXS[7:0] for MTX9 through MTX2, respectively	0x58
SIGN	HV[0] for MTX1	0x69
ENABLE	COM13[4] 0: Disable Matrix 1: Enable Matrix	0x3D
DOUBLER	COM16[1] 0: Directly use Matrix 1: Double Matrix	0x41

Each matrix component has 9-bits(1-bit sign and 8-bit data). This 3x3 matrix can be described as shown below:

M1 M2 M3
M4 M5 M6
M7 M8 M9

And, the sign is assigned as shown below:

HV[0] (0x69) sign bit of the MTX1
MTXS[0] (0x58) sign bit of the MTX2
MTXS[1] (0x58) sign bit of the MTX3
MTXS[2] (0x58) sign bit of the MTX4
MTXS[3] (0x58) sign bit of the MTX5
MTXS[4] (0x58) sign bit of the MTX6
MTXS[5] (0x58) sign bit of the MTX7
MTXS[6] (0x58) sign bit of the MTX8
MTXS[7] (0x58) sign bit of the MTX9

5.2.1.1 Color Correction Matrix

Below is the OV9650 color correction matrix:

1.43	-0.36	-0.07
-0.24	1.38	-0.14
-0.05	-0.66	1.71

5.2.1.2 RGB to YUV conversion Matrix

Below is the OV9650 RGB to YUV conversion matrix.

5 /16	9/16	2/16
-5 /16	-9/16	14/16
11/16	-9/16	-2/16

5.2.1.3 Hue Control

1	0	0
0	$\cos\alpha$	$\sin\alpha$
0	$\sin\alpha$	$-\cos\alpha$

5.2.1.4 Color Saturation

1	0	0
0	Gain	0
0	0	Gain

5.2.1.5 Final Matrix

In OV9650, the M1M2M3 and M7M8M9 is swapped in YUV and RGB mode as shown below:

In YUV output mode:

- $Y' = r * M7 + g * M8 + b * M9$
- $U' = r * M4 + g * M5 + b * M6$
- $V' = r * M1 + g * M2 + b * M3$

In RGB output mode:

- $R' = r * M1 + g * M2 + b * M3$
- $G' = r * M4 + g * M5 + b * M6$
- $B' = r * M7 + g * M8 + b * M9$

YUV Derivation from RGB:

- $Y: 0.59G + 0.31R + 0.11B$
- $U: B - Y$
- $V: R - Y$

YCbCr Derivation from RGB:

- $Y: 0.59G + 0.31R + 0.11B$
- $Cb: 0.563 (B - Y)$
- $Cr: 0.713 (R - Y)$

B&W Derivation from RGB:

- Y Channel

Preliminary

5.3 Sharpness Control

The OV9650 features digital sharpness enhancement. It detects edge first and then, amplifies the edge difference only.

Table 5-3. Color Matrix Related Registers and Parameters

Function	Register	Address	Note
Sharpness Enable	COM14[1]	0x3E	Active high
Edge Detect Threshold	COM22[7:6], EDGE[7:4]	0x8C 0x3F	00 0000 is minimum threshold
Edge Enhancement	EDGE[3:0]	0x3F	0000 is minimum enhancement
Double Edge Enhancement	COM14[0]	0x3E	Active high

5.4 Noise-Canceling

The OV9650 has a built-in noise-canceling circuit to reduce noise. Setting register COM22[5] (0x8C) to high enables the noise-canceling function.

5.5 White Pixel Correction

The OV9650 has a built-in white pixel correction circuit. Setting register COM22[1:0] (0x8C) to "11" enables the white pixel correction function.

5.6 Digital Black Level Calibration

The OV9650 calibrates black level automatically. Setting register TSLB[0] (0x3A) to high enables black level calibration function.

5.7 Lens Shading Correction

Because of the non-uniform light transparency, the outer areas of the image appears darker than the center area. The lens correction function amplifies the outer areas of the image to obtain a uniform image.

Figure 5-2 Lens Shading Correction

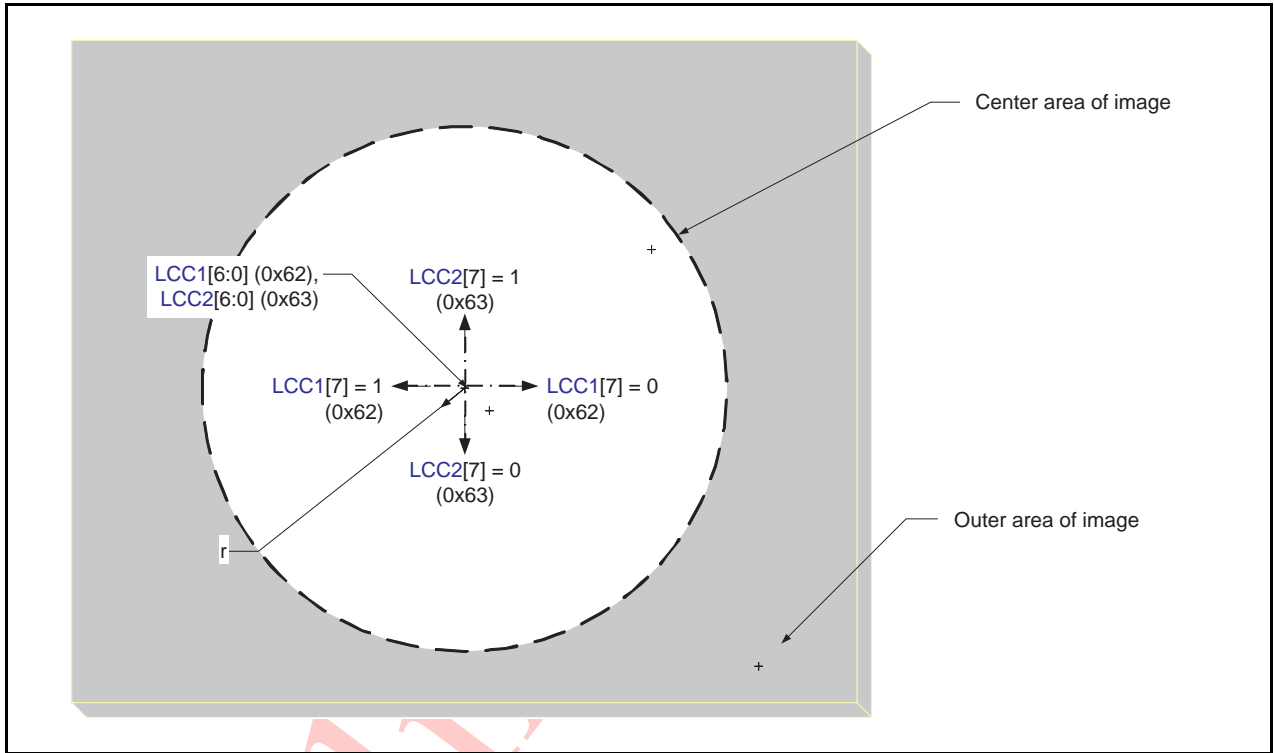

Table 5-4. Lens Shading Correction Registers and Parameters

Function	Register	Address	Note
Lens Correction Center Coordinates X Default LC_XY = (X,Y) = (0,0)	LCC1[6:0] LCC1[7] 0: Offset LCC1[6:0] to +X direction 1: Offset LCC1[6:0] to -X direction	0x62	Lens Correction Center Coordinates X, one bit equals one pixel in full resolution.
Lens Correction Center Coordinates Y Default LC_XY = (X,Y) = (0,0)	LCC2[6:0] LCC2[7] 0: Offset LCC2[6:0] to +Y direction 1: Offset LCC2[6:0] to -Y direction	0x63	Lens Correction Center Coordinates Y, one bit equals one line in full resolution.
Radius of the circular section where lens correction is not needed	LCC4	0x65	
Green Gain Parameter/ 3-channel (R, G and B) Gain Parameter	LCC3	0x64	Green gain parameter if LCC5[2] = 1; Gain parameter for R,G,B channels if LCC5[2] = 0
Multi-Gain Control	LCC5[2] 0: Use register LCC3 for gain parameter for R, G, and B channels 1: Use register LCC3 for Green Gain parameter, LCCFB for Blue Gain parameter, and LCCFR for Red Gain parameter LCC5[0] 0: Disable lens correction 1: Enable lens correction	0x66	
Blue Gain Parameter	LCCFB	0x9D	Not used if LCC5[2] = 0
Red Gain Parameter	LCCFR	0x9E	Not used if LCC5[2] = 0

6 Output Formatter

This block controls all output and data formatting required prior to sending the image out on D[9:0]. [Table 6-1](#) lists the control registers for the Output Formatting functions.

Table 6-1. Output Formatting General Controls

Function		Register	Address
Mirror Image Enable		MVFP[5]	0x1E
Vertical Flip Enable		MVFP[4]	0x1E
YUV/YCbCr Mode		COM7[2] = 0	0x12
RGB Mode	Raw RGB	COM7[2] = 1, COM7[0] = 1	0x12
	GRB 4:2:2	COM7[2] = 1, COM7[0] = 0, COM15[4] = 0	0x12, 0x40
	RGB:565	COM7[2] = 1, COM7[0] = 0, COM15[5] = 0, COM15[4] = 1	0x12, 0x40
	RGB:555	COM7[2] = 1, COM7[0] = 0, COM15[5] = 1, COM15[4] = 1	0x12, 0x40

RGB:565 and RGB:555 are alternate output formats where each color is represented by different D[9:2] bit widths (see [Table 6-2](#)).

Table 6-2. RGB:555 and RGB:565 Output Format Controls

Format	D[9:2]		
	Red	Green	Blue
RGB:565	RRRR Rxxx	GGGG GGxx	BBBB Bxxx
RGB:555	RRRR Rxxx	GGGG Gxxx	BBBB Bxxx

This format uses an odd/even byte pair to express the color for each pixel:

- RGB:565

Bytes	D9	D8	D7	D6	D5	D4	D3	D2
Even	R7	R6	R5	R4	R3	G7	G6	G5
Odd	G4	G3	G2	B7	B6	B5	B4	B3

- RGB:555

Bytes	D9	D8	D7	D6	D5	D4	D3	D2
Even	00	R7	R6	R5	R4	R3	G7	G6
Odd	G5	G4	G3	B7	B6	B5	B4	B3

6.1 Windowing

The OV9650 CAMERACHIP windowing feature allows the users to define the active pixels used in the final image (frame) as required for low-resolution applications. Selecting the Start/Stop Row/Column addresses (modifying window size and/or position) does not change the frame or data rate. When windowing is enabled, the HREF signal is asserted to be consistent with the programmed 'active' horizontal and vertical region. Table 6-3 lists the control registers

Table 6-3. Windowing Control Registers

Function	Register	Address
Horizontal Frame (HREF Column) Start	HSTART[7:0] HREF[2:0]	0x17 0x32
Horizontal Frame (HREF Column) Stop	HSTOP[7:0] HREF[5:3]	0x18 0x32
Vertical Frame (Row) Start	VSTRT[7:0] VREF[2:0]	0x19 0x03
Vertical Frame (Row) Stop	VSTOP[7:0] VREF[5:3]	0x1A 0x03

Figure 6-1 shows an example of a windowed frame.

Figure 6-1 Example of Windowing

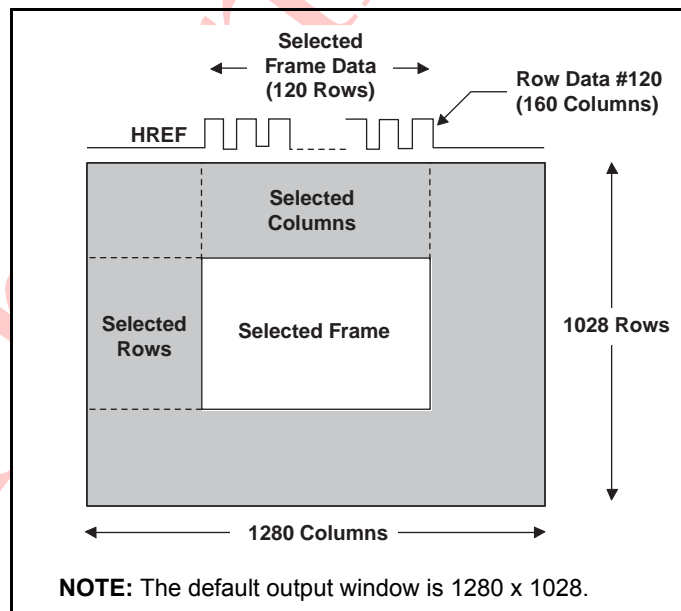

OV9650 windowing function can be implemented with the sub-sampling mode for the camera zoom function. For example, if the preview image size is 160 x 120 (QQVGA), the camera can be set to output QQQVGA sub-sampling mode, then set to output QVGA mode (320 x 240) and use the windowing function to capture center-quarter area (160 x 120) to implement the 2x zoom-in function. Then, the camera can be set to VGA mode (640 x 480) or SXGA (1280 x 1028) mode, to implement 4x and 8x zoom-in function.

6.2 Data Formatting

Table 6-4 lists the registers used for Data Formatting.

Table 6-4. Data Formatting (Sheet 1 of 2)

Function	Register	Address	Note	
HSYNC/VSYNC Polarity	COM10[1:0]	0x15	High: Negative	
HREF Polarity	COM10[3]	0x15	High: Negative	
YUV Formatting	COM7[2]	0x12	0: YUV 1: RGB	
YUV Sequence Exchange	TSLB[3:2]	0x3A	00: YVYU 01: YUYV 10: VYUY 11: UYVY	
Output Data MSB/LSB Swap Enable	COM3[6]	0x0C	8-bits: D[9:2] 10-bits: D[9:0]	
D[9:0] - PCLK Reference Edge	COM10[4]	0x15	0: Data update at falling edge 1: Data update at rising edge	
ITU-656 Format Enable	COM1[6]	0x04	High: Enable	
Output Range	COM15[7:6]	0x40	00: 0x10 to 0xF0 01: 0x10 to 0xF0 10: 0x01 to 0xFE 11: 0x00 to 0xFF	
Frame Rate Adjust Setting (by inserting dummy pixels)	EXHCH[6:4] (MSB) EXHCL[7:0] (LSB)	0x2A 0x2B	SXGA	LSB: 1/1520 Line Period increase
			VGA	LSB: 1/1600 Line Period increase
			QVGA	LSB: 1/1600 Line Period increase
			QQVGA	LSB: 1/1600 Line Period increase
			CIF	LSB: 1/1040 Line Period increase
			QCIF	LSB: 1/1040 Line Period increase
			QQCIF	LSB: 1/1040 Line Period increase
Frame Rate Adjust Setting (by inserting dummy lines)	DM_LNH[7:0] (MSB) DM_LNL[7:0] (LSB)	0x93 0x92	SXGA	LSB: 1/1050 Frame Period increase
			VGA	LSB: 1/500 Frame Period increase
			QVGA	LSB: 1/250 Frame Period increase
			QQVGA	LSB: 1/250 Frame Period increase
			CIF	LSB: 1/384 Frame Period increase
			QCIF	LSB: 1/192 Frame Period increase
			QQCIF	LSB: 1/192 Frame Period increase

Table 6-4. Data Formatting (Sheet 2 of 2)

Function	Register	Address	Note
Auto Frame Rate Adjust Range	COM11[6:5]	0x3B	00: Frame rate does not change 01: Minimum 1/2 frame rate 10: Minimum 1/4 frame rate 11: Minimum 1/8 frame rate
Pixel Delay Select	PSHFT[7:0]	0x1B	
Output HSYNC on HREF Pin Enable	COM10[6]	0x15	0: HREF 1: HSYNC
PCLK Output Gated by HREF Enable	COM10[5]	0x15	0: Free running PCLK 1: PCLK gated by HREF
HSYNC Rising Edge Delay	EXHCH[1:0] (MSB) HSYST[7:0] (LSB)	0x2A 0x30	
HSYNC Falling Edge Delay	EXHCH[3:2] (MSB) HSYEN[7:0] (LSB)	0x2A 0x31	
VSYNC and HREF/DATA drop	COM9[2:1]	0x14	Drop over-exposure image

6.2.1 ITU-656 Format Enable

Instead of using HREF to define each row, the ITU-656 standard inserts a 4-byte header before and after the row data.

Header Footer: [FF] [00] [00] [Sync Byte]

OmniVision suggests using output range control register COM15[7:6] (0x40) to limit image data range so that the image data does not contain 0x00 and 0xFF.

6.2.2 Frame Rate Adjust

The OV9650 offers three methods of frame rate adjustment using the clock prescaler (see Section 3.3.1), by inserting 'dummy' pixels in each row's output, and by inserting dummy lines in each frame output. By inserting these dummy pixels (using EXHCH[6:4] (0x2A) and EXHCL[7:0] (0x2B)), the frame rate can be changed while leaving the pixel unchanged.

Dummy Pixel Number = EXHCH[6:4] (0x2A) + EXHCL[7:0] (0x2B)

Refer to Table 6-4 for the number of dummy pixels that changes the frame rate.

By inserting dummy lines at frame output, the user can get the same data rate and the same data read out time at one frame.

Also, in low light (night mode) conditions, the user can turn on auto frame adjust to decrease the random noise and increase the sensitivity (get more exposure time). In this mode, COM11[7] (0x3B) is high. COM11[6:5] (0x3B) is used to control the frame adjust range. See Table 6-4 for details.

6.2.3 Output Data MSB/LSB Swap Enable

See Figure 6-2 for details when MSB/LSB output data swap is enabled.

Figure 6-2 MSB/LSB Output Data Swap

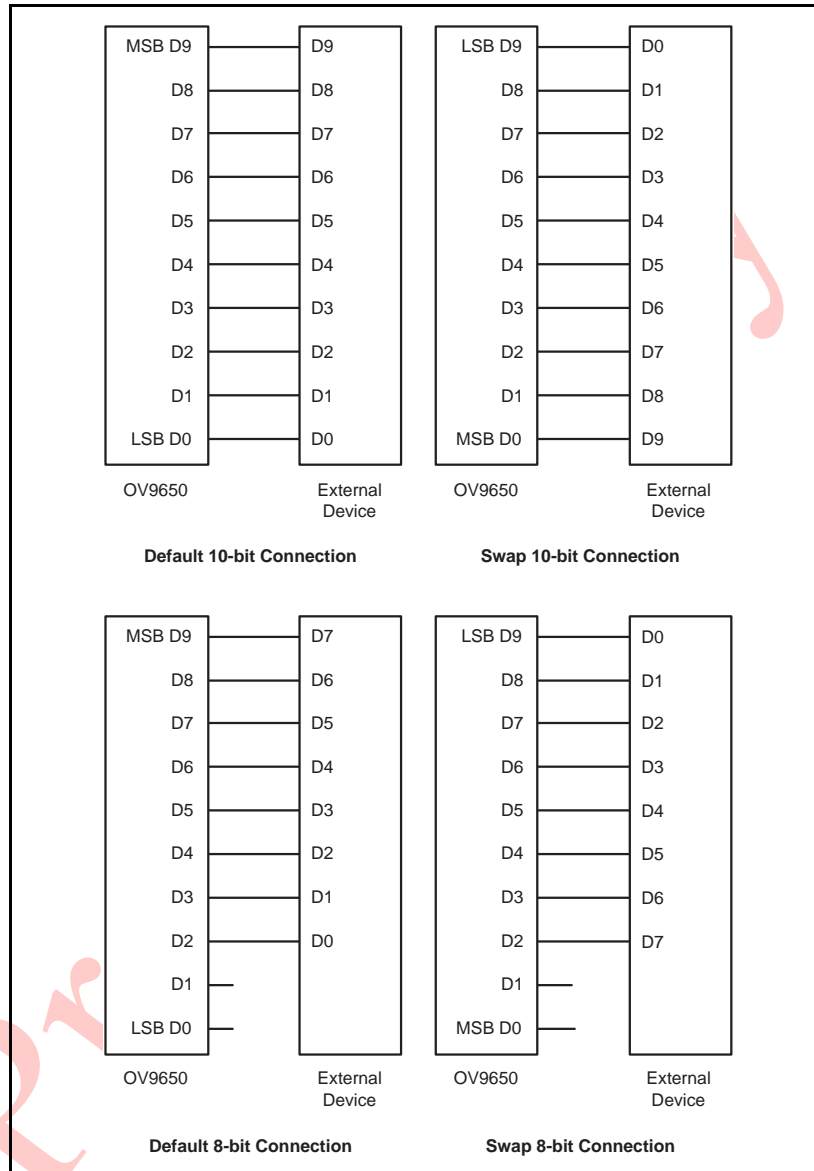

6.2.4 D[9:0] - PCLK Reference Edge

To conserve the user's memory space, the PCLK output can be gated by HREF, which defines the active video period.

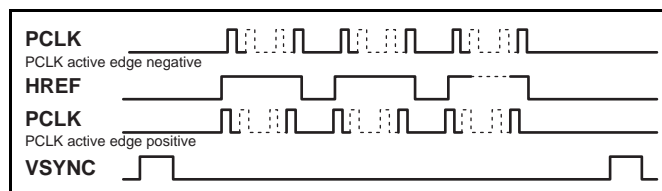

7 Digital Video Port

The two bits shown in Table 7-1 are used to increase I_{OL}/I_{OH} drive current and can be adjusted as a function of the customer's D[9:0], HREF, VSYNC, and PCLK loading.

Table 7-1. Output Drive Current

Function	Register	Address	Value
1x I_{OL}/I_{OH} Enable	COM2[1:0]	0x09	2b'00
2x I_{OL}/I_{OH} Enable	COM2[1:0]	0x09	2b'01 or 2b'10
4x I_{OL}/I_{OH} Enable	COM2[1:0]	0x09	2b'11

8 Special Image Effects

Table 8-1. Special Image Effects

Mode	Register	Address	Value
Normal Color	TSLB[7:0]	0x3A	0x01
	MANU[7:0]	0x67	0x80
	MANV[7:0]	0x68	0x80
Black & White	TSLB[1:0]	0x3A	0x11
	MANU[7:0]	0x67	0x80
	MANV[7:0]	0x68	0x80
Sepia	TSLB[1:0]	0x3A	0x11
	MANU[7:0]	0x67	0x40
	MANV[7:0]	0x68	0xA0
Blush	TSLB[1:0]	0x3A	0x11
	MANU[7:0]	0x67	0xC0
	MANV[7:0]	0x68	0x80
Reddish	TSLB[1:0]	0x3A	0x11
	MANU[7:0]	0x67	0x80
	MANV[7:0]	0x68	0xC0
Greenish	TSLB[1:0]	0x3A	0x11
	MANU[7:0]	0x67	0x40
	MANV[7:0]	0x68	0x40
Negative	TSLB[1:0]	0x3A	0x21
	MANU[7:0]	0x67	0x80
	MANV[7:0]	0x68	0x80

9 Preview Mode to Still Image Capture Sequence

The procedure for OV9650 preview mode to still image capture sequence for different resolution and frame rate is as follows:

1. Preview image
2. Press still image button
3. Read out sensor below register values:
 - Gain: Register GAIN[9:0] {VREF[7:6] (0x03), GAIN[7:0] (0x00)}
 - Exposure: Register AEC[15:0] {AECHM[15:10] (0xA1), AECH[9:2] (0x10), COM1[1:0] (0x04)}
4. Set sensor to still image resolution (just change a few registers that are different to preview)
 - Turn off sensor AGC and AEC by setting register COM8[2] and COM8[0] (0x13) to low, respectively
 - Calculate and set the gain {VREF[7:6] (0x03), GAIN[7:0] (0x00)} and exposure time {AECHM[15:10] (0xA1), AECH[9:2] (0x10), COM1[1:0] (0x04)} of the still image from the gain and exposure time of the preview image
5. Wait for two frames and capture the third frame
6. Set back to preview mode and turn on AGC and AEC
7. Preview image

AEC[15:0] responds to horizontal line period for each bit. Horizontal line period includes an active pixel period and a horizontal blanking period. It counts both active pixel number and blanking pixel number. So the line period will be:

- 1520Tp (1280+240) for SXGA
- 800Tp (640+160) for VGA:
- 400Tp (320+80) for QVGA
- 400Tp ((160+40)x2) for QQVGA
- 520Tp (352+168) for CIF
- 260Tp (176+84) for QCIF
- 260Tp ((88+42)x2) for QQCIF

where Tp depends on the frame rate.

9.1 Exposure Time and Gain Calculation

To get the same luminance level, the product of exposure time and gain of the still image should be the same as the preview image. To reduce still image noise, always set the exposure time "high" and the gain "low". If the frame rate of the preview image is higher than that of the still image, convert as much gain as possible to exposure time. Refer to [Table 4-1](#) for the gain calculation. The maximum exposure time $AEC[15:0] = \{AECHM[15:10] (0xA1), AECH[9:2] (0x10), COM1[1:0] (0x04)\}$ is dependent on the resolution:

- SXGA: 000001 00000110 00 (1048)
- VGA: 000000 01111100 10 (498)
- QVGA: 000000 00111110 00 (248)
- QQVGA: 000000 00111110 00 (248)
- CIF: 000000 01011111 10 (382)
- QCIF: 000000 00101111 10 (190)
- QQCIF: 000000 00101111 10 (190)

10 SCCB Interface

The *OmniVision Serial Camera Control Bus (SCCB) Functional Specification* is available at <http://www.ovt.com>. The Functional Specification provides complete information for using the SCCB to control the features of an OmniVision CAMERACHIP.

The OV9650 CAMERACHIP uses the SCCB protocol to control the features noted in this document via the companion backend system ASIC. The device slave addresses of the OV9650 CAMERACHIP are: 0x60 for write (7-bit address and 1-bit write) and 0x61 for read (7-bit address and 1-bit read). The first command in the SCCB transmission must be a register reset, as most registers will rely on the default value setting.

10.1 Control Functions

[Table 10-1](#) lists the SCCB control functions.

Table 10-1. SCCB Control Functions

Function	Register	Address
Register Reset	COM7[7]	0x12
Standby Mode Enable	COM2[4]	0x09
Tri-state Enable – D[9:0]	COM17[1]	0x42

10.1.1 Register Reset

All registers can be reset to their default values by using the RESET pin (RESET to VDD_IO) or by using the SCCB interface (see register [COM7\[7\]](#) (0x12)). OmniVision suggests putting the reset register setting (set register [COM7](#) (0x12) to 0x80) at the beginning of the sensor initialization. After software reset, wait 1 ms for the next register access (there is no limitation for other register settings).

10.1.2 Standby Mode Enable

The OV9650 CAMERACHIP can be placed in Standby mode by using the PWDN pin (PWDN to VDD_IO) or by using the SCCB interface (see register [COM2\[4\]](#) (0x09)). Note that using the PWDN pin results in lower Standby current (see Electrical Characteristics in the [OV9650 Datasheet](#)).

Setting register [OFON\[3\]](#) (0x39) to high before standby can reduce the current a little bit.

10.1.2.1 Standby Mode Using the PWDN Pin

Internal device clock is halted and all internal counters are reset to their default values and all SCCB registers remain unchanged.

10.1.2.2 Standby Mode Using the SCCB Interface

Suspends internal circuit activity but does not halt the device clock.

10.1.3 Tri-state Enable

This bit control will immediately tri-state the data outputs. However, all internal signals will continue to be generated and transfer to the output as if it were active. It is the user's responsibility to ensure that the tri-state command is used after all functions have completed their operation.

If the device is put into Standby mode, all outputs, including data and clock, are automatically tri-stated.

10.2 Register Set

Table 10-2 provides a list and description of the Device Control registers contained in the OV9650. For all register Enable/Disable bits, ENABLE = 1 and DISABLE = 0. The device slave addresses for the OV9650 are 0x60 for write and 0x61 for read.

For factory-recommended settings, contact your local OmniVision FAE.



Note: All registers shown as reserved have no function or are very sensitive analog circuit references. Use OmniVision reference values (not default values).

Table 10-2. Device Control Register List

Address (Hex)	Register Name	Default (Hex)	R/W	Description
00	GAIN	00	RW	AGC[7:0] – Gain control gain setting • Range: [00] to [FF]
01	BLUE	80	RW	AWB – Blue channel gain setting • Range: [00] to [FF]
02	RED	80	RW	AWB – Red channel gain setting • Range: [00] to [FF]
03	VREF	12	RW	Vertical Frame Control Bit[7:6]: AGC[9:8] (see register GAIN for AGC[7:0]) Bit[5:3]: VREF end low 3 bits (high 8 bits at VSTOP [7:0]) Bit[2:0]: VREF start low 3 bits (high 8 bits at VSTRT [7:0])
04	COM1	00	RW	Common Control 1 Bit[7]: Reserved Bit[6]: CCIR656 format Bit[5]: QQVGA or QQCIF format. Effective only when QVGA (register bit COM7 [4]) or QCIF (register bit COM7 [3]) output is selected and related HREF skip option based on format is selected (register COM1[3:2]) Bit[4]: Reserved Bit[3:2]: HREF skip option 00: No skip 01: YUV/RGB skip every other row for YUV/RGB, skip 2 rows for every 4 rows for Raw data 1x: Skip 3 rows for every 4 rows for YUV/RGB, skip 6 rows for every 8 rows for Raw data Bit[1:0]: AEC low 2 LSB (see registers AECM for AEC[15:10] and AEC for AEC[9:2])
05	BAVE	00	RW	U/B Average Level Automatically updated based on chip output format
06	GEAVE	00	RW	Y/Ge Average Level Automatically updated based on chip output format
07	RSVD	00	–	Reserved

Table 10-2. Device Control Register List (Continued)

Address (Hex)	Register Name	Default (Hex)	R/W	Description
08	RAVE	00	RW	V/R Average Level Automatically updated based on chip output format
09	COM2	01	RW	Common Control 2 Bit[7:5]: Reserved Bit[4]: Soft sleep mode Bit[3:2]: Reserved Bit[1:0]: Output drive capability 00: 1x 01: 2x 10: 3x 11: 4x
0A	PID	96	R	Product ID Number MSB (Read only)
0B	VER	52	R	Product ID Number LSB (Read only)
0C	COM3	00	RW	Common Control 3 Bit[7]: Reserved Bit[6]: Output data MSB and LSB swap Bit[5:4]: Reserved Bit[3]: Pin selection 1: Change RESET pin to EXPST_B (frame exposure mode timing) and change PWDN pin to FREX (frame exposure enable) Bit[2]: VarioPixel for VGA, CIF, QVGA, QCIF, QQVGA, and QQCIF Bit[1]: Reserved Bit[0]: Single frame output (used for Frame Exposure mode only)
0D	COM4	00	RW	Common Control 4 Bit[7]: VarioPixel for QVGA, QCIF, QQVGA, and QQCIF Bit[6:3]: Reserved Bit[2]: Tri-state option for output clock at power-down period 0: Tri-state at this period 1: No tri-state at this period Bit[1]: Tri-state option for output data at power-down period 0: Tri-state at this period 1: No tri-state at this period Bit[0]: Reserved
0E	COM5	01	RW	Common Control 5 Bit[7]: System clock selection. If the system clock is 48 MHz, this bit should be set to high to get 15 fps for YUV or RGB Bit[6:5]: Reserved Bit[4]: Slam mode enable 0: Master mode 1: Slam mode (used for slave mode) Bit[3:0]: Reserved

Table 10-2. Device Control Register List (Continued)

Address (Hex)	Register Name	Default (Hex)	R/W	Description
0F	COM6	43	RW	<p>Common Control 6</p> <p>Bit[7]: Output of optical black line option 0: Disable HREF at optical black 1: Enable HREF at optical black</p> <p>Bit[6:4]: Reserved</p> <p>Bit[3]: Enable bias for ADBLC</p> <p>Bit[2]: ADBLC offset 0: Use 4-channel ADBLC 1: Use 2-channel ADBLC</p> <p>Bit[1]: Reset all timing when format changes</p> <p>Bit[0]: Enable ADBLC option</p>
10	AECH	40	RW	<p>Exposure Value</p> <p>Bit[7:0]: AEC[9:2] (see registers AECHM for AEC[15:10] and COM1 for AEC[1:0])</p>
11	CLKRC	00	RW	<p>Data Format and Internal Clock</p> <p>Bit[7]: Digital PLL option 0: Disable double clock option, meaning the maximum PCLK can be as high as half input clock 1: Enable double clock option, meaning the maximum PCLK can be as high as input clock</p> <p>Bit[6]: Use input clock directly (no clock pre-scale available)</p> <p>Bit[5:0]: Internal clock pre-scalar $F(\text{internal clock}) = F(\text{input clock}) / (\text{Bit}[5:0] + 1)$ • Range: [0 0000] to [1 1111]</p>
12	COM7	00	RW	<p>Common Control 7</p> <p>Bit[7]: SCCB Register Reset 0: No change 1: Resets all registers to default values</p> <p>Bit[6]: Output format - VGA selection</p> <p>Bit[5]: Output format - CIF selection</p> <p>Bit[4]: Output format - QVGA selection</p> <p>Bit[3]: Output format - QCIF selection</p> <p>Bit[2]: Output format - RGB selection</p> <p>Bit[1]: Reserved</p> <p>Bit[0]: Output format - Raw RGB (COM7[2] must be set high)</p>
13	COM8	8F	RW	<p>Common Control 8</p> <p>Bit[7]: Enable fast AGC/AEC algorithm</p> <p>Bit[6]: AEC - Step size limit (used only in fast condition and COM5[0] is low) 0: Fast condition change maximum step is VSYNC 1: Unlimited step size</p> <p>Bit[5]: Banding filter ON/OFF</p> <p>Bit[4:3]: Reserved</p> <p>Bit[2]: AGC Enable</p> <p>Bit[1]: AWB Enable</p> <p>Bit[0]: AEC Enable</p>

Table 10-2. Device Control Register List (Continued)

Address (Hex)	Register Name	Default (Hex)	R/W	Description
14	COM9	4A	RW	<p>Common Control 9</p> <p>Bit[7]: Reserved</p> <p>Bit[6:4]: Automatic Gain Ceiling - maximum AGC value</p> <p>000: 2x</p> <p>001: 4x</p> <p>010: 8x</p> <p>011: 16x</p> <p>100: 32x</p> <p>101: 64x</p> <p>110: 128x</p> <p>Bit[3]: Exposure timing can be less than limit of banding filter when light is too strong</p> <p>Bit[2]: Data format - VSYNC drop option</p> <p>0: VSYNC always exists</p> <p>1: VSYNC will drop when frame data drops</p> <p>Bit[1]: Enable drop frame when AEC step is larger than the Exposure Gap</p> <p>Bit[0]: Freeze AGC/AEC</p>
15	COM10	00	RW	<p>Common Control 10</p> <p>Bit[7]: Set pin definition</p> <p>1: Set RESET to SLHS (slave mode horizontal sync) and set PWDN to SLVS (slave mode vertical sync)</p> <p>Bit[6]: HREF changes to HSYNC</p> <p>Bit[5]: PCLK output option</p> <p>0: PCLK always output</p> <p>1: No PCLK output when HREF is low</p> <p>Bit[4]: PCLK reverse</p> <p>Bit[3]: HREF reverse</p> <p>Bit[2]: Reserved</p> <p>Bit[1]: VSYNC negative</p> <p>Bit[0]: HSYNC negative</p>
16	RSVD	00	-	Reserved
17	HSTART	1A	RW	Output Format - Horizontal Frame (HREF column) start high 8-bit (low 3 bits are at HREF[2:0])
18	HSTOP	BA	RW	Output Format - Horizontal Frame (HREF column) end high 8-bit (low 3 bits are at HREF[5:3])
19	VSTRT	01	RW	Output Format - Vertical Frame (row) start high 8-bit (low 3 bits are at VREF[2:0])
1A	VSTOP	81	RW	Output Format - Vertical Frame (row) end high 8-bit (low 3 bits are at VREF[5:3])
1B	PSHFT	00	RW	<p>Data Format - Pixel Delay Select (delays timing of the D[9:0] data relative to HREF in pixel units)</p> <ul style="list-style-type: none"> Range: [00] (no delay) to [FF] (256 pixel delay which accounts for whole array)
1C	MIDH	7F	R	Manufacturer ID Byte – High (Read only = 0x7F)

Table 10-2. Device Control Register List (Continued)

Address (Hex)	Register Name	Default (Hex)	R/W	Description
1D	MIDL	A2	R	Manufacturer ID Byte – Low (Read only = 0xA2)
1E	MVFP	00	RW	Mirror/VFlip Enable Bit[7:6]: Reserved Bit[5]: Mirror 0: Normal image 1: Mirror image Bit[4]: VFlip enable 0: VFlip disable 1: VFlip enable Bit[3:0]: Reserved
1F	LAEC	00	RW	Reserved
20	BOS	80	RW	B Channel ADBLC Result Bit[7]: Offset adjustment sign 0: Add offset 1: Subtract offset Bit[6:0]: Offset value of 10-bit range (high 7 bits)
21	GBOS	80	RW	Gb channel ADBLC result Bit[7]: Offset adjustment sign 0: Add offset 1: Subtract offset Bit[6:0]: Offset value of 10-bit range
22	GROS	80	RW	Gr channel ADBLC result Bit[7]: Offset adjustment sign 0: Add offset 1: Subtract offset Bit[6:0]: Offset value of 10-bit range
23	ROS	80	RW	R channel ADBLC result Bit[7]: Offset adjustment sign 0: Add offset 1: Subtract offset Bit[6:0]: Offset value of 10-bit range
24	AEW	78	RW	AGC/AEC - Stable Operating Region (Upper Limit)
25	AEB	68	RW	AGC/AEC - Stable Operating Region (Lower Limit)
26	VPT	D4	RW	AGC/AEC Fast Mode Operating Region Bit[7:4]: High nibble of upper limit Bit[3:0]: High nibble of lower limit
27	BBIAS	80	RW	B Channel Signal Output Bias (effective only when COM6[0] = 1) Bit[7]: Bias adjustment sign 0: Add bias 1: Subtract bias Bit[6:0]: Bias value of 10-bit range

Table 10-2. Device Control Register List (Continued)

Address (Hex)	Register Name	Default (Hex)	R/W	Description
28	GbBIAS	80	RW	Gb Channel Signal Output Bias (effective only when COM6[0] = 1) Bit[7]: Bias adjustment sign 0: Add bias 1: Subtract bias Bit[6:0]: Bias value of 10-bit range
29	Gr_COM	00	RW	Analog BLC and Regulator Control Bit[7:6]: Reserved Bit[5]: Bypass Analog BLC Bit[4]: Bypass regulator Bit[3:0]: Reserved
2A	EXHCH	00	RW	Dummy Pixel Insert MSB Bit[7]: Reserved Bit[6:4]: 3 MSB for dummy pixel insert in horizontal direction Bit[3:2]: HSYNC falling edge delay 2 MSB Bit[1:0]: HSYNC rising edge delay 2 MSB
2B	EXHCL	00	RW	Dummy Pixel Insert LSB 8 LSB for dummy pixel insert in horizontal direction
2C	RBIAS	80	RW	R Channel Signal Output Bias (effective only when COM6[0] = 1) Bit[7]: Bias adjustment sign 0: Add bias 1: Subtract bias Bit[6:0]: Bias value of 10-bit range
2D	ADVFL	00	RW	LSB of insert dummy lines in vertical direction (1 bit equals 1 line)
2E	ADVFH	00	RW	MSB of insert dummy lines in vertical direction
2F	YAVE	00	RW	Y/G Channel Average Value
30	HSYST	08	RW	HSYNC Rising Edge Delay (low 8 bits)
31	HSYEN	30	RW	HSYNC Falling Edge Delay (low 8 bits)
32	HREF	A4	RW	HREF Control Bit[7:6]: HREF edge offset to data output Bit[5:3]: HREF end 3 LSB (high 8 MSB at register HSTOP) Bit[2:0]: HREF start 3 LSB (high 8 MSB at register HSTART)
33	CHLF	00	RW	Bit[7:0]: Reserved
34	ARBLM	03	RW	Bit[7:0]: Reserved
35-36	RSVD	XX	-	Reserved
37	ADC	04	RW	Bit[7:0]: Reserved
38	ACOM	12	RW	Bit[7:0]: Reserved
39	OFON	00	RW	Bit[7:4]: Reserved Bit[3]: Line buffer power down - must be set to "1" before chip power down Bit[2:0]: Reserved

Table 10-2. Device Control Register List (Continued)

Address (Hex)	Register Name	Default (Hex)	R/W	Description
3A	TSLB	0C	RW	<p>Line Buffer Test Option</p> <p>Bit[7:6]: Reserved</p> <p>Bit[5]: Bit-wise reverse</p> <p>Bit[4]: UV output value</p> <p>0: Use normal UV output</p> <p>1: Use fixed UV value set in registers MANU and MANV as UV output instead of chip output</p> <p>Bit[3:2]: Output sequence is Y U Y V instead of U Y V Y</p> <p>00: Y U Y V</p> <p>01: Y V Y U</p> <p>10: V Y U Y</p> <p>11: U Y V Y</p> <p>Bit[1]: Reserved</p> <p>Bit[0]: Digital BLC enable</p> <p>0: Disable</p> <p>1: Enable</p>
3B	COM11	00	RW	<p>Common Control 11</p> <p>Bit[7]: Night mode</p> <p>0: Night mode disable</p> <p>1: Night mode enable - If the AGC gain goes over 2, then AGC gain drops to 0 and frame rate changes by half. COM11[6:5] limits the minimum frame rate. Also, ADVFL and ADVFL will be automatically updated.</p> <p>Bit[6:5]: Night mode insert frame option</p> <p>00: Normal frame rate</p> <p>01: 1/2 frame rate</p> <p>10: 1/4 frame rate</p> <p>11: 1/8 frame rate</p> <p>Bit[4:3]: Average calculation window option</p> <p>00: Use full frame</p> <p>01: Use half frame</p> <p>10: Use quarter frame</p> <p>11: Not allowed</p> <p>Bit[2:1]: Reserved</p> <p>Bit[0]: Manual banding filter enable</p>
3C	COM12	40	RW	<p>Common Control 12</p> <p>Bit[7]: HREF option</p> <p>0: No HREF when VREF is low</p> <p>1: Always has HREF</p> <p>Bit[6:3]: Reserved</p> <p>Bit[2]: Enable UV average</p> <p>Bit[1:0]: Reserved</p>

Table 10-2. Device Control Register List (Continued)

Address (Hex)	Register Name	Default (Hex)	R/W	Description
3D	COM13	99	RW	<p>Common Control 13</p> <p>Bit[7:6]: Gamma selection for signal 00: No gamma function 01: Gamma used for Y channel only 10: Gamma used for Raw data before interpolation 11: Not allowed</p> <p>Bit[5]: Reserved</p> <p>Bit[4]: Enable color matrix for RGB or YUV</p> <p>Bit[3]: Enable Y channel delay option 0: Delay UV channel 1: Delay Y channel</p> <p>Bit[2:0]: Output Y/UV delay</p>
3E	COM14	0E	RW	<p>Common Control 14</p> <p>Bit[7:2]: Reserved</p> <p>Bit[1]: Enable edge enhancement for YUV output (effective only for YUV/RGB, no use for Raw data)</p> <p>Bit[0]: Edge enhancement option 0: Edge enhancement factor = EDGE[3:0] 1: Edge enhancement factor = 2 x EDGE[3:0]</p>
3F	EDGE	88	RW	<p>Edge Enhancement Adjustment</p> <p>Bit[7:4]: Edge enhancement threshold[3:0] (see register COM22[7:6] for Edge threshold[5:4])</p> <p>Bit[3:0]: Edge enhancement factor</p>
40	COM15	C0	RW	<p>Common Control 15</p> <p>Bit[7:6]: Data format - output full range enable 0x: Output range: [10] to [F0] 10: Output range: [01] to [FE] 11: Output range: [00] to [FF]</p> <p>Bit[5:4]: RGB 555/565 option (must set COM7[2] high) x0: Normal RGB output 01: RGB 565 11: RGB 555</p> <p>Bit[3]: Swap R/B in RGB565/RGB555 format</p> <p>Bit[2:0]: Reserved</p>
41	COM16	10	RW	<p>Common Control 16</p> <p>Bit[7:2]: Reserved</p> <p>Bit[1]: Color matrix coefficient double option</p> <p>Bit[0]: Reserved</p>
42	COM17	08	RW	<p>Common Control 17</p> <p>Bit[7:3]: Reserved</p> <p>Bit[2]: Select single frame out</p> <p>Bit[1]: Tri-state output after single frame out</p> <p>Bit[0]: Banding Filter Value selection 0: Use Banding Filter Value stored in register BD60ST 1: Use Banding Filter Value stored in register BD50ST</p>

Table 10-2. Device Control Register List (Continued)

Address (Hex)	Register Name	Default (Hex)	R/W	Description
43-4E	RSVD	XX	–	Reserved
4F	MTX1	58	RW	Matrix Coefficient 1
50	MTX2	48	RW	Matrix Coefficient 2
51	MTX3	10	RW	Matrix Coefficient 3
52	MTX4	28	RW	Matrix Coefficient 4
53	MTX5	48	RW	Matrix Coefficient 5
54	MTX6	70	RW	Matrix Coefficient 6
55	MTX7	40	RW	Matrix Coefficient 7
56	MTX8	40	RW	Matrix Coefficient 8
57	MTX9	40	RW	Matrix Coefficient 9
58	MTXS	0F	RW	Matrix Coefficient Sign for coefficient 9 to 2 0: Plus 1: Minus
59-61	RSVD	XX	–	Reserved
62	LCC1	00	RW	Lens Correction Option 1 Bit[7]: Direction of offset on X-axis Bit[6:0]: Offset value
63	LCC2	00	RW	Lens Correction Option 2 Bit[7]: Direction of offset on Y-axis Bit[6:0]: Offset value
64	LCC3	10	RW	Lens Correction Option 3
65	LCC4	80	RW	Lens Correction Option 4
66	LCC5	00	RW	Lens Correction Control Bit[7:3]: Reserved Bit[2]: Lens correction control select 0: Use LCC3 for Red, Green, and Blue channel control (LCCFB and LCCFR are not used) 1: Use LCC3 for Green channel control, LCCFB for Blue channel control and LCCFR for Red channel control Bit[1]: Reserved Bit[0]: Lens correction enable
67	MANU	80	RW	Manual U Value (effective only when register TSLB[4] is high)
68	MANV	80	RW	Manual V Value (effective only when register TSLB[4] is high)
69	HV	00	RW	Manual Banding Filter MSB Bit[7:6]: B channel pre-gain Bit[5:4]: R channel pre-gain Bit[3:1]: Reserved Bit[0]: Matrix coefficient 1 sign

Table 10-2. Device Control Register List (Continued)

Address (Hex)	Register Name	Default (Hex)	R/W	Description
6A	MBD	00	RW	Manual Banding Filter Value (effective only when COM11[0] is high).
6B	DBLV	0A	RW	Bit[7:0]: Reserved
6C-7B	GSP	XX	RW	Gamma curve
7C-8A	GST	XX	RW	Gamma curve
8B	COM21	04	RW	Common Control 21 Bit[7:0]: Reserved
8C	COM22	00	RW	Common Control 22 Bit[7:6]: Edge enhancement threshold[5:4] (see register EDGE[7:4] for Edge threshold[3:0]) Bit[5]: De-noise enable Bit[4:2]: Reserved Bit[1]: White-pixel erase enable Bit[0]: White-pixel erase option
8D	COM23	00	RW	Common Control 23 Bit[7:5]: Reserved Bit[4]: Color bar test mode Bit[3:2]: Reserved Bit[1]: Digital color gain enable Bit[0]: Reserved
8E	COM24	00	RW	Common Control 24 Bit[7:0]: Reserved
8F	DBLC1	0F	RW	Digital BLC Offset Sign Bit[7:4]: Reserved Bit[3]: Digital BLC B offset sign Bit[2]: Digital BLC R offset sign Bit[1]: Digital BLC Gb offset sign Bit[0]: Digital BLC Gr offset sign
90	DBLC_B	00	RW	Digital BLC B Channel Offset Value Bit[7:0]: Digital BLC B channel offset value
91	DBLC_R	00	RW	Digital BLC R Channel Offset Value Bit[7:0]: Digital BLC R channel offset value
92	DM_LNL	00	RW	Dummy Line low 8 bits Bit[7:0]: Control insert Dummy line[7:0]
93	DM_LNH	00	RW	Dummy Line high 8 bits Bit[7:0]: Control insert Dummy line[15:8]
94-9C	RSVD	XX	–	Reserved
9D	LCCFB	00	RW	Lens Correction B Channel Control (if LCC3[2] = 1)
9E	LCCFR	00	RW	Lens Correction R Channel Control (if LCC3[2] = 1)

Table 10-2. Device Control Register List (Continued)

Address (Hex)	Register Name	Default (Hex)	R/W	Description
9F	DBLC_Gb	00	RW	Digital BLC Gb Channel Offset Value Bit[7:0]: Digital BLC Gb channel offset value
A0	DBLC_Gr	00	RW	Digital BLC Gr Channel Offset Value Bit[7:0]: Digital BLC Gr channel offset value
A1	AECHM	40	RW	Exposure Value - AEC MSB 6 bits Bit[7:6]: Reserved Bit[5:0]: AEC[15:10] (see registers AECH for AEC[9:2] and COM1 for AEC[1:0])
A2	BD50ST	9D	RW	Banding Filter Value (effective only when COM11 [0] is low and COM17 [0] is high)
A3	BD60ST	83	RW	Banding Filter Value (effective only when COM11 [0] is low and COM17 [0] is low)
A4	COM25	00	RW	Common Control 25 Bit[7:0]: Reserved
A5	COM26	00	RW	Common Control 26 Bit[7:0]: Reserved
A6	G_GAIN	80	RW	Reserved
A7	VGA_ST	14	RW	Reserved
A8-AA	ACOM	XX	-	Reserved

NOTE: All other registers are factory-reserved. Please contact OmniVision Technologies for reference register settings.

11 Prototyping and Evaluation Modules

OmniVision Technologies Inc. supplies prototyping and evaluation modules to demonstrate operation of the associated CAMERACHIP products, as well as to demonstrate associated companion backend processor, where required.

11.1 OV9650EAA Prototyping Module

The OV9650EAA prototyping module is used for general design-in and evaluation purposes. The module provides a simple 32-pin header-connector interface to the relevant I/O and control registers in the OV9650 CAMERACHIP. The module includes the necessary sensor, lens/holder, a few capacitors, and resistors.

The OV9650EAA prototyping module can be directly connected to any companion backend processor solution or system interface. The header-connector interface allows for access to the 10-bit digital output data, PCLK, vertical sync, horizontal sync and SCCB signals. The backend interface can use the Serial Camera Control Bus (SCCB) interface software to adjust the control register values.

11.2 OV9650ECX USB 2.0 Evaluation Module

The OV9650ECX USB2.0 evaluation module is provided so that potential customers may evaluate both the live video function of the CAMERACHIP as well as the SCCB control interface software. The OV9650 CAMERACHIP output is a RGB raw data or YUV stream connected to a USB 2.0 controller operating at a high-speed bus data rate (480 Mbps).

Using a high performance computer system with a USB 2.0 host (cannot guarantee for every system), the OV9650 USB module will stream video in SXGA format (1280x1028 at 15 fps), VGA format (640x480 at 30 fps) or in QVGA format (320x240 at 60 fps). This configuration requires a Windows® 2000 or XP operating system. Additionally, the SCCB software allows the evaluator to adjust the image characteristics in real-time.

12 Lens selection

The OV9650 is a quarter-inch format CAMERACHIP that is compatible with numerous lenses in the market. The key considerations in lens selection are lens quality and resultant cost. OmniVision Technologies, Inc. has qualified several lens suppliers for the various formats, sizes, and quality of lenses available. OmniVision has developed a Lens Supplier Partner List to complement our CAMERACHIP products. This listing is available at <http://www.ovt.com> on the Partners page. Contact your local OmniVision FAE for recommended OV9650 lenses.

13 OV9650 Bug List

None as of this revision.

Appendix A Reference SCCB Settings

Contact your local OmniVision FAE for updated reference register settings.

Preliminary

Note:

- *All information shown herein is current as of the revision and publication date. Please contact OmniVision to obtain the current version of this documentation.*
- *OmniVision Technologies, Inc. reserves the right to make changes to their products or to discontinue any product or service without further notice (It is advisable to obtain current product documentation prior to placing orders).*
- *Reproduction of information in OmniVision product documentation and specifications is permissible only if reproduction is without alteration and is accompanied by all associated warranties, conditions, limitations and notices. In such cases, OmniVision is not responsible or liable for any information reproduced.*
- *This document is provided with no warranties whatsoever, including any warranty of merchantability, non-infringement, fitness for any particular purpose, or any warranty otherwise arising out of any proposal, specification or sample. Furthermore, OmniVision Technologies Inc. disclaims all liability, including liability for infringement of any proprietary rights, relating to use of information in this document. No license, expressed or implied, by estoppels or otherwise, to any intellectual property rights is granted herein.*
- *'OmniVision', 'CameraChip', and 'OmniPixel' are trademarks of OmniVision Technologies, Inc. All other trade, product or service names referenced in this release may be trademarks or registered trademarks of their respective holders. Third-party brands, names, and trademarks are the property of their respective owners.*

For further information, please feel free to contact OmniVision at info@ovt.com.

**OmniVision Technologies, Inc.
1341 Orleans Drive
Sunnyvale, CA USA
(408) 542-3000**

Preliminary