



LIGITEK

LIGITEK ELECTRONICS CO.,LTD.
Property of Ligitek Only

TAPE AND BOX TYPE LED LAMPS



Lead-Free Parts

LPD4380-PF/TBS-X

DATA SHEET

DOC. NO : QW0905-LPD4380-PF/TBS-X

REV. : A

DATE : 28 - Feb. - 2008



Package Dimensions

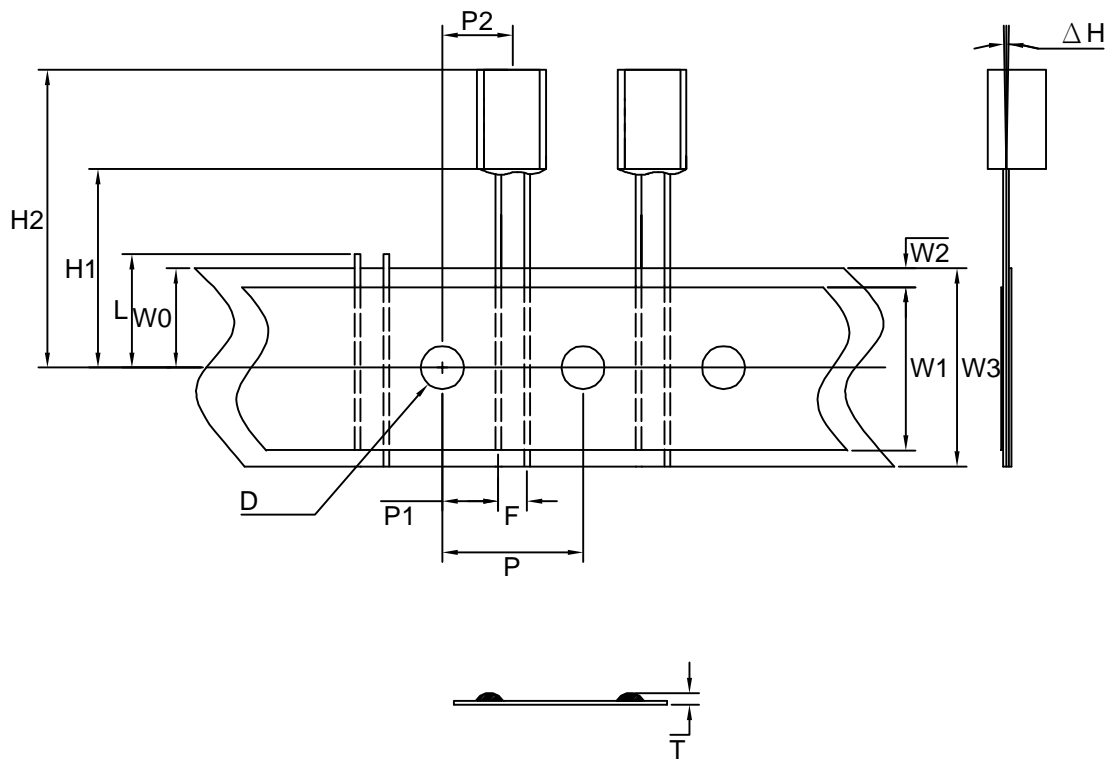



Package Dimension

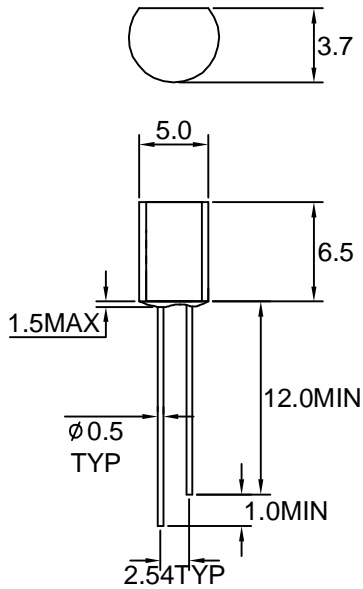

Description

The LPD4380-PF/TBS-X series are silicon planar P/N photodiodes incorporated in plastic package that simultaneously serve as filter and are also Transparent for infrared emission their terminals are soldering tabs arranged in 2.54mm center to center spacing due to their design the diodes can vertically be assembled on pc boards arrays can be realized by multiple arrangement versatile photodetectors are suitable for diodes as well as voltaic cell operation the signal noise ratio is particularly favorable even at low illuminance the P/N photodiode are outstanding for low junction capacitance high cut-off frequency and fast switching times.

They are particularly suitable for IR sound transmission and remote control the cathode of LPD4380-PF/TBS-X photodiode is marked by a stamping on the package edge

NOTE:1.All dimension are In millimeters tolerance Is ± 0.25 unless otherwise noted
2.Specifications are subject to change without notice

• MAXIMUM RATINGS (TA=25°C)

| Characteristic | Symbol | Rating | Unit |
|----------------------------|------------------|-----------|------|
| Reversr Break Down Voltage | V _{BR} | 30 | V |
| Power Dissipation | PD | 150 | mW |
| Operating Temperature | T _{opr} | -30 - +60 | °C |
| Storage Temperature | T _{stg} | -40 - +60 | °C |

• ELECTRICAL CHARACTERISTICS AT (TA=°C)

| Characteristic | Symbol | Test Condition | Min | Typ | Max | Unit |
|------------------------------------|--------------------------------|---|-----|-----|-----|------|
| Dark Current | I _d | V _R =10V E _e =0mW/cm ² | — | 1.0 | 30 | nA |
| Short Circuit Current | I _{sc} | V _R =5V λ _P =940nm E _e =0.5mW/cm ² | 2.0 | 3.0 | — | uA |
| Open Circuit Voltage | V _{oc} | λ _P =940nm E _e =0.5mW/cm ² | — | 350 | — | mV |
| Reverse Light Current | I _{ra} | V _R =5V λ _P =940nm E _e =0.5mW/cm ² | 2.0 | 3.0 | — | uA |
| Total Capacitance | C _T | V _R =3V f=1MHZ E _e =0mW/cm ² | — | 20 | — | pF |
| Peak Wavelength of Max Sensitivity | λ _{smax} | | — | 940 | — | nm |
| Rise Time,Fall Time | t _r ,t _f | V _R =10V R _L =1KΩ | — | 50 | — | ns |



• Dimension Symbol Information

| SYMBOL ITEMS | OPTION CODE | SYMBOL | SPECIFICATIONS | | | |
|------------------------------------|---------------------------------------|--------|----------------|-------|---------|-------|
| | | | Minimum | | Maximum | |
| | | | mm | inch | mm | inch |
| Tape Feed Hole Diameter | ----- | D | 3.8 | 0.15 | 4.2 | 0.17 |
| Component Lead Pitch | ----- | F | 2.3 | 0.09 | 3.0 | 0.12 |
| Front-To-Rear Deflection | ----- | △H | ----- | ----- | 2.0 | 0.08 |
| Feed Hole To Bottom Of Component | TBS-1 | H1 | 17.5 | 0.69 | 18.5 | 0.73 |
| | TBS-2 | | 21.5 | 0.85 | 22.5 | 0.89 |
| | TBS-3 | | 25.5 | 1.0 | 26.5 | 1.04 |
| | TBS-5 | | 22.5 | 0.89 | 23.5 | 0.93 |
| | TBS-6 | | 19.9 | 0.78 | 20.9 | 0.82 |
| | TBS-7 | | 24.0 | 0.94 | 25.0 | 0.98 |
| | TBS-8 | | 24.5 | 0.96 | 25.5 | 1.0 |
| | TBS-9 | | 19.0 | 0.75 | 20.0 | 0.79 |
| | TBS-10 | | 18.4 | 0.72 | 19.4 | 0.76 |
| | TBS-11 | | 21.0 | 0.83 | 22.0 | 0.87 |
| | TBS-12 | | 20.5 | 0.81 | 21.5 | 0.85 |
| | TBS-13 | | 18.0 | 0.71 | 19.0 | 0.75 |
| | Feed Hole To Overall Component Height | | ----- | H2 | ----- | ----- |
| Lead Length After Component Height | ----- | L | W0 | | 11 | 0.43 |
| Feed Hole Pitch | ----- | P | 12.4 | 0.49 | 13 | 0.51 |
| Lead Location | ----- | P1 | 4.4 | 0.17 | 5.8 | 0.23 |
| Center Of Component Location | ----- | P2 | 5.1 | 0.2 | 7.7 | 0.3 |
| Overall Taped Package Thickness | ----- | T | ----- | ----- | 1.42 | 0.06 |
| Feed Hole Location | ----- | W0 | 8.5 | 0.33 | 9.75 | 0.38 |
| Adhesive Tape Width | ----- | W1 | 14.5 | 0.57 | 15.5 | 0.61 |
| Adhesive Tape Position | ----- | W2 | 0 | 0 | 4.0 | 0.16 |
| Tape Width | ----- | W3 | 17.5 | 0.69 | 19 | 0.75 |

REMARK:TBS=Tape And Box Straight Leads

• Dimensions Symbol Information

• Package Dimensions

| Description | Symbol | Specification | | | |
|-------------------|---------|---------------|------|---------|------|
| | | minimum | | maximum | |
| | | mm | inch | mm | inch |
| Overall Length | L | 330 | 13.0 | 340 | 13.4 |
| Overall Width | W | 265 | 10.4 | 275 | 10.8 |
| Overall Thickness | H | 50 | 1.97 | 60 | 2.4 |
| Quantity/Box | 2000PCS | | | | |

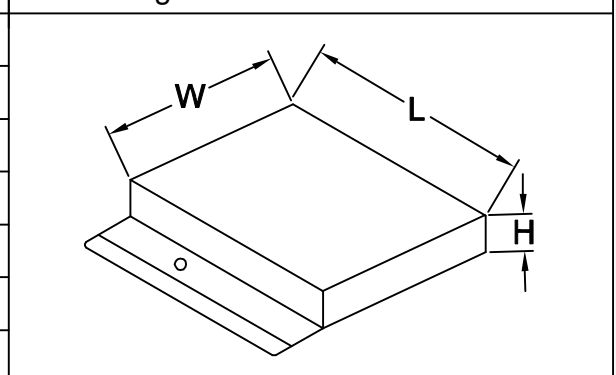



Soldering Condition(Pb-Free)

1.Iron:

- Soldering Iron:30W Max
- Temperature 350° C Max
- Soldering Time:3 Seconds Max(One Time)
- Distance:2mm Min(From solder joint to body)

2.Wave Soldering Profile

- Dip Soldering
- Preheat: 120° C Max
- Preheat time: 60seconds Max
- Ramp-up
- 2° C/sec(max)
- Ramp-Down:-5° C/sec(max)
- Solder Bath:260° C Max
- Dipping Time:3 seconds Max
- Distance:2mm Min(From solder joint to body)

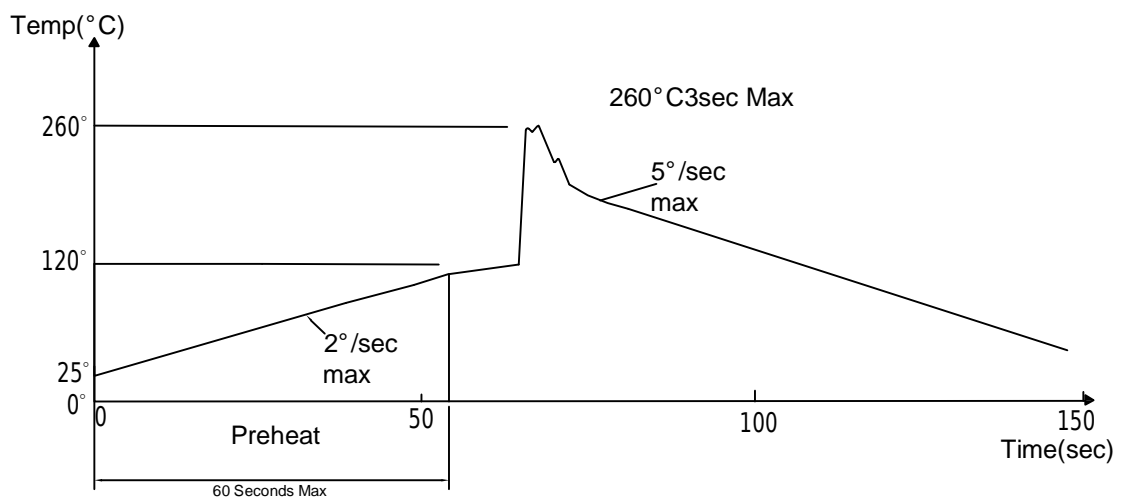

Note: 1.Wave solder should not be made more than one time.
2.You can just only select one of the soldering conditions as above.



Reliability Test:

| Test Item | Test Condition | Description | Reference Standard |
|-------------------------------------|--|---|--|
| Operating Life Test | 1.Under Room Temperature 2.If=20mA 3.t=1000 hrs (-24hrs, +72hrs) | This test is conducted for the purpose of determining the resistance of a part in electrical and thermal stressed. | MIL-STD-750: 1026 MIL-STD-883: 1005 JIS C 7021: B-1 |
| High Temperature Storage Test | 1.Ta=105 °C±5°C 2.t=1000 hrs (-24hrs, +72hrs) | The purpose of this is the resistance of the device which is laid under condition of high temperature for hours. | MIL-STD-883:1008 JIS C 7021: B-10 |
| Low Temperature Storage Test | 1.Ta=-40 °C±5°C 2.t=1000 hrs (-24hrs, +72hrs) | The purpose of this is the resistance of the device which is laid under condition of low temperature for hours. | JIS C 7021: B-12 |
| High Temperature High Humidity Test | 1.Ta=65 °C±5°C 2.RH=90%~95% 3.t=240hrs±2hrs | The purpose of this test is the resistance of the device under tropical for hours. | MIL-STD-202:103B JIS C 7021: B-11 |
| Thermal Shock Test | 1.Ta=105 °C±5°C & -40 °C±5°C (10min) (10min) 2.total 10 cycles | The purpose of this is the resistance of the device to sudden extreme changes in high and low temperature. | MIL-STD-202: 107D MIL-STD-750: 1051 MIL-STD-883: 1011 |
| Solder Resistance Test | 1.T.Sol=260 °C±5°C 2.Dwell time= 10 ±1sec. | This test intended to determine the thermal characteristic resistance of the device to sudden exposures at extreme changes in temperature when soldering the lead wire. | MIL-STD-202: 210A MIL-STD-750: 2031 JIS C 7021: A-1 |
| Solderability Test | 1.T.Sol=230 °C±5°C 2.Dwell time=5 ±1sec | This test intended to see soldering well performed or not. | MIL-STD-202: 208D MIL-STD-750: 2026 MIL-STD-883: 2003 JIS C 7021: A-2 |