

1. PART NO. EXPRESSION :

S	D	C	0	6	0	3	2	R	0	M	Z	F	(a) Series code	(d) Tolerance code : M = ±20%
(a)	(b)	(c)	(d)(e)(f)	(b) Dimension code	(e) X, Y, Z : Standard part									
				(c) Inductance code : 2R0 = 2.0uH	(f) F : Lead Free									

2. CONFIGURATION & DIMENSIONS :

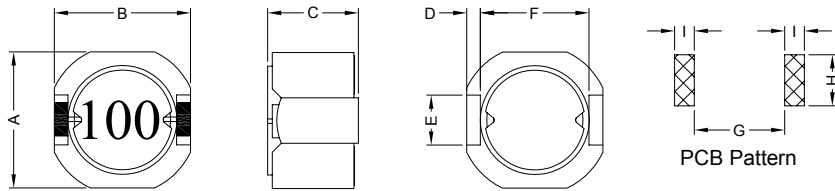

Unit:m/m

A	B	C	D	E	F	G	H	I
6.2 Max.	6.30±0.3	3.5 Max.	0.6 Typ.	2.0 Typ.	4.8 Typ.	4.6 Ref.	2.6 Ref.	1.0 Ref.

3. SCHEMATIC :

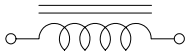

4. MATERIALS :

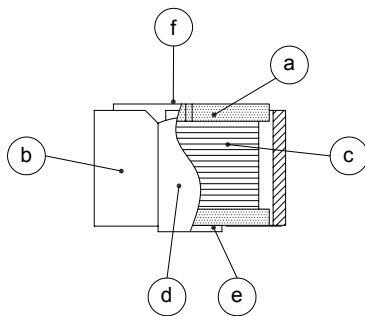

- (a) Core : DR Ferrite Core
- (b) Core : RI Ferrite Core
- (c) Wire : Enamelled Copper Wire
- (d) Lead : Tinned Copper Wire
- (e) Adhesive : Epoxy
- (f) Ink : Bon Margue

5. GENERAL SPECIFICATION :

- a) Irms : Temp. rise 40°C Max.
- b) Isat : ΔL/L0A=30% Max.
- c) Storage temp. : -40°C to +125°C
- d) Operating temp. : -40°C to +85°C
- e) Resistance to solder heat : 260°C.10 secs



RoHS Compliant

NOTE : Specifications subject to change without notice. Please check our website for latest information.

05.05.2008



SUPERWORLD ELECTRONICS (S) PTE LTD

6. ELECTRICAL CHARACTERISTICS :

Part No.	Inductance (μ H)	Test Freq. (Hz)	RDC (m Ω) Typ.	Isat (A) Max.	Irms (A) Max.
SDC06032R0MZF	2.0 \pm 20%	100K	19.1	2.997	3.30
SDC06032R7MZF	2.7 \pm 20%	100K	22.0	2.691	3.12
SDC06033R3MZF	3.3 \pm 20%	100K	25.7	2.573	2.81
SDC06034R7MZF	4.7 \pm 20%	100K	31.6	2.084	2.51
SDC06036R2MZF	6.2 \pm 20%	100K	35.0	1.835	2.41
SDC06038R2MZF	8.2 \pm 20%	100K	43.5	1.542	2.11
SDC0603100MZF	10.0 \pm 20%	100K	49.4	1.491	1.97
SDC0603120MZF	12.0 \pm 20%	100K	62.0	1.282	1.73
SDC0603150MZF	15.0 \pm 20%	100K	77.0	1.103	1.54
SDC0603180MZF	18.0 \pm 20%	100K	81.5	1.046	1.52
SDC0603220MZF	22.0 \pm 20%	100K	106.0	0.968	1.29
SDC0603270MZF	27.0 \pm 20%	100K	140.0	0.821	1.11
SDC0603330MZF	33.0 \pm 20%	100K	162.0	0.755	1.02
SDC0603390MZF	39.0 \pm 20%	100K	192.0	0.700	0.96
SDC0603470MZF	47.0 \pm 20%	100K	209.0	0.677	0.89
SDC0603560MZF	56.0 \pm 20%	100K	257.0	0.602	0.80
SDC0603680MZF	68.0 \pm 20%	100K	320.0	0.556	0.71
SDC0603820MZF	82.0 \pm 20%	100K	420.0	0.468	0.61
SDC0603101MZF	100.0 \pm 20%	100K	477.0	0.449	0.57
SDC0603151MZF	150.0 \pm 20%	100K	664.0	0.367	0.48



RoHS Compliant

NOTE : Specifications subject to change without notice. Please check our website for latest information.

05.05.2008



SUPERWORLD ELECTRONICS (S) PTE LTD

RECOMMENDED SOLDERING CONDITIONS REFLOW SOLDERINGS

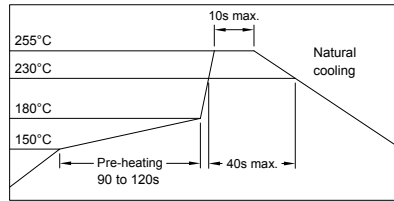

7. PACKAGING INFORMATION :

(1) CONFIGURATION

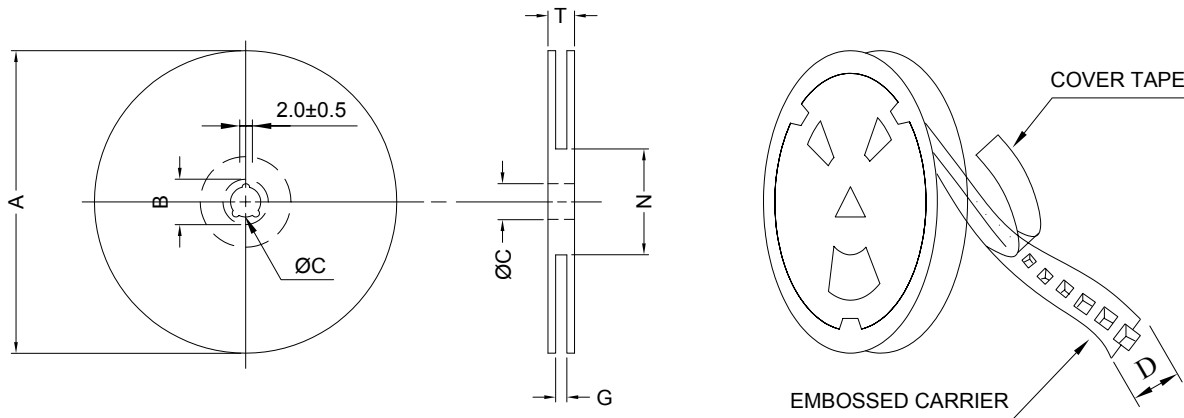

* CARRIER TAPE WIDTH : D

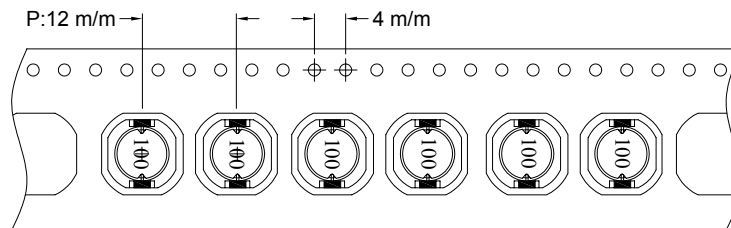

(2) DIMENSIONS

Unit:m/m

STYLE	A	B	C	D	G	N	T
13-16	330	21±0.8	13	16	18 ⁺⁰	50 ⁻⁰	22.4

(3) Q'TY & G.W. PER PACKAGE

SERIES	INNER : REEL			OUTER : CARTON		
	Q'TY (PCS)	G.W. (gw)	STYLE	Q'TY (PCS)	G.W. (Kg)	SIZE (cm)
SDC0603	1000	800	13-16	6000	8.3	40 x 40 x 24



RoHS Compliant

NOTE : Specifications subject to change without notice. Please check our website for latest information.

05.05.2008



SUPERWORLD ELECTRONICS (S) PTE LTD

8. RELIABILITY AND TEST CONDITION :

TEST ITEM	SPECIFICATION	TEST CONDITION
SOLDERABILITY	MORE THAN 90% OF THE TERMINAL ELECTRODE SHALL BE COVERED WITH FRESH SOLDER.	PREHEAT : 125±25°C FOR 60 SECONDS SOLDER : 99%Sn/0.3%Ag/0.7%Cu OR EQUIVALENT SOLDER TEMP. : 245±5°C FLUX : ROSIN DIP TIME : 4±1 SECONDS
THERMAL SHOCK TEST (TEMP. CYCLE)	INDUCTANCE SHALL NOT CHANGE MORE THAN ±20%	ROOM TEMP. → -25±2°C 15 MINUTES → 30 MINUTES ROOM TEMP. → 85±2°C 15 MINUTES → 30 MINUTES TOTAL : 50 CYCLES
HUMIDITY RESISTANCE TEST		TEMPERATURE : 40±2°C HUMIDITY : 90 ~ 95% APPLIED CURRENT : PER SPEC. TIME : 500 HOURS
HIGH TEMP. RESISTANCE TEST		TEMPERATURE : 85±2°C APPLIED CURRENT : PER SPEC. TIME : 500 HOURS



RoHS Compliant

NOTE : Specifications subject to change without notice. Please check our website for latest information.

05.05.2008



SUPERWORLD ELECTRONICS (S) PTE LTD

PG. 4

9. UL CARD :

OBMW2		November 30, 2000		
Magnet Wire - Component				
PACIFIC ELECTRIC WIRE & CABLE (SHENZHEN) CO LTD				E201757
607 BAOLONG INDUSTRIAL ESTATE LONGGANG, SHENZHEN				
GUANGDONG CHINA				
		Coating Type		
Mtl Dsg	BC	TC	ANSI Type	TI
UEW/U	Polyurethane	—	—	130
PEW/U	Polyester	—	MW5-C	155°C
PEWH/U	Modified Polyester	—	MW30-C	180
PEW-NY/U	Polyester	Polyamide	MW24-C	155
HAI/U	Polyester(Amide)(Imide)	Polyamideimide	MW35,73	200
UEW-NY/U	Polyurethane	Polyamide	MW80-C	155
			MW28-C	130

Marking: Company name and material designation or marked designation on package or reel, and Recognized Component Mark.

See General Information Preceding These Recognitions

1/3/2001 Underwriters Laboratories Inc. Card 1 of 2



RoHS Compliant

NOTE : Specifications subject to change without notice. Please check our website for latest information.

05.05.2008



SUPERWORLD ELECTRONICS (S) PTE LTD