

1. Mechanical Dimensions:

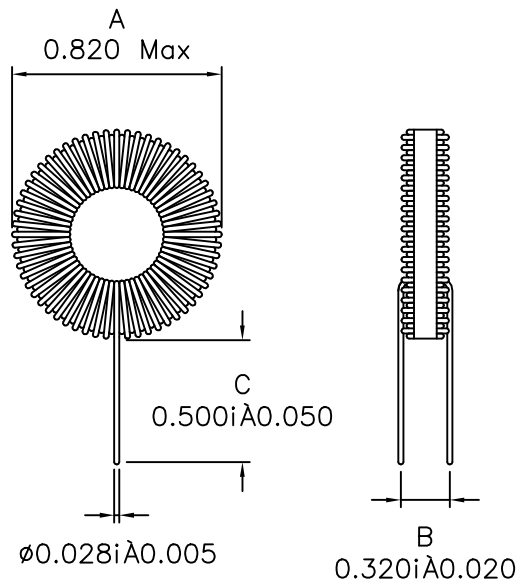

2. Schematic:

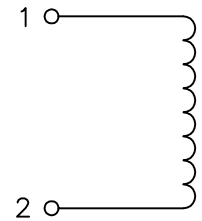

3. Electrical Specifications:

Inductance: 100uH ±10% @1.0KHz,1.0V

CURRENT RATING: 2.0ADC

DC Resistance: 0.070 Ohms Max.

Note:

1. Solderability: Leads shall meet MIL-STD-202, Method 208D for solderability.
2. Flammability: UL94V-0,
3. ASTM oxygen index: > 28% ,
4. Temperature rating: 155°C. UL file E151556,
5. Operating Temperature Range: -30°C to +85°C

DOC. REV. A/1

XFMRs Inc.	Title: INDUCTOR		
	UNLESS OTHERWISE SPECIFIED		P/N: 1XF0100-VO
	TOLERANCES:		REV. A
	.xxx ±0.010		DWN. 廖玉坤 Sep-21-01
Dimensions in Inch		CHK. 李清儿 Sep-21-01	
SHEET 1 OF 1		APP. BW Sep-21-01	