



LIGITEK

LIGITEK ELECTRONICS CO.,LTD.
Property of Ligitek Only

TAPE AND BOX TYPE LED LAMPS

LPT3323/TBS-1

DATA SHEET

DOC. NO : QW0905-LPT3323/TBS-1

REV. : E

DATE : 29 - Apr. - 2006



Package Dimension

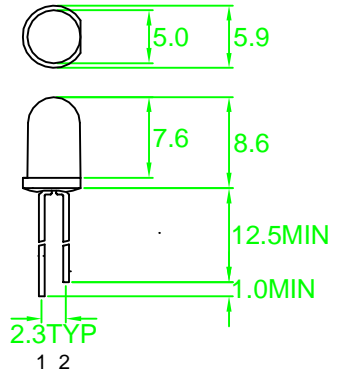
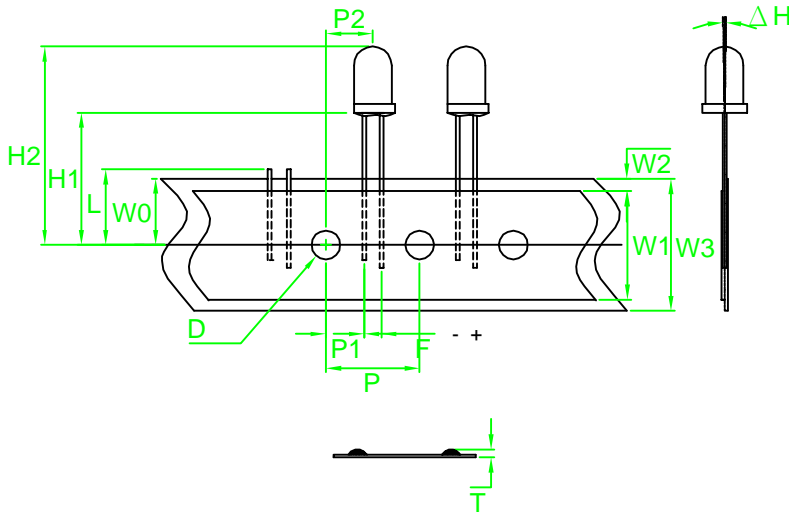

1.EMITTER
2.COLLECTOR

- Features
- . High illumination sensitivity
 - . Stable characteristics
 - . Spectrally and mechanically matched with IR emitter

Description

The LPT3323/TBS-1 series are silicon nitride passivated NPN planar phototransistors with exceptionally table characteristics and igh illumination sensitivity the cases of LPT3323/TBS-1 are ncapsulated in water clear plastic T1 3/4 package individualt

Note:1.All dimension are in millimeter tolerance is $\pm 0.25\text{mm}$ unless otherwise noted
2.Specifications are subject to change without notice

• MAXIMUM RATINGS($T_a=25^\circ\text{C}$)

PARAMETER	MAXIMUM RATINGS	UNIT
Power Dissipation	100	mw
Collector-Emitter Voltage	30	V
Emitter-Collector Voltage	5	V
Operating Temperature	-50°C TO +100°C	
Storage Temperature	-50°C TO +100°C	
Lead Soldering Temperature(1.6mm From Body)	260°C for 5 seconds	

• ELECTRICAL CHARACTERISTICS($T_a=25^\circ\text{C}$)

PARAMETER	SYMBOL	Min.	Typ.	Max.	UNIT	TEST CONDITION
Collector-Emitter Breakdown Voltage	$V_{(BR)CEO}$	30			V	$I_c=1\text{mA}$ $E_e=0\text{mw/cm}^2$
Emitter-Collector Breakdown Voltage	$V_{(BR)ECO}$	5			V	$I_E=100\ \mu\text{A}$ $E_e=0\text{mw/cm}^2$
Collector-Emitter Saturation Voltage	$V_{CE(sat)}$			0.4	V	$I_c=0.5\text{mA}$ $E_e=20\text{mw/cm}^2$
Rise Time	T_r		5		μs	$V_{CE}=30\text{V}$ $I_C=800\ \mu\text{A}, R_L=1\text{K}\Omega$
Fall Time	T_f		5		μs	
Collector Dark Current	I_{CEO}			100	nA	$V_{CE}=10\text{V}$ $E_e=0\text{mw/cm}^2$
On State Collector Current	$I_p(\text{on})$	1		2	mA	$V_{CE}=5\text{v}$ $E_e=1\text{mw/cm}^2$ $\lambda P=940\text{nm}$
		2		4	mA	
		4		8	mA	
		8			mA	



• Dimension Symbol Information

SYMBOL ITEMS	OPTION CODE	SYMBOL	SPECIFICATIONS			
			Minimum		Maximum	
			mm	inch	mm	inch
Tape Feed Hole Diameter	-----	D	3.8	0.15	4.2	0.17
Component Lead Pitch	-----	F	2.2	0.09	3.0	0.12
Front-To-Rear Deflection	-----	△H	-----	-----	2.0	0.08
Feed Hole To Bottom Of Component	TBS-1	H1	17.5	0.69	18.5	0.73
Feed Hole To Overall Component Height	-----	H2	-----	-----	36	1.42
Lead Length After Component Height	-----	L	W0		11	0.43
Feed Hole Pitch	-----	P	12.4	0.49	13	0.51
Lead Location	-----	P1	4.4	0.17	5.8	0.23
Center Of Component Location	-----	P2	5.1	0.2	7.7	0.3
Overall Taped Package Thickness	-----	T	-----	-----	1.42	0.06
Feed Hole Location	-----	W0	8.5	0.33	9.75	0.38
Adhesive Tape Width	-----	W1	14.5	0.57	15.5	0.61
Adhesive Tape Position	-----	W2	0	0	4.0	0.16
Tape Width	-----	W3	17.5	0.69	19	0.75

REMARK:TBS=Tape And Box Straight Leads

• Dimensions Symbol Information

• Package Dimensions

Description	Symbol	Specification			
		minimum		maximum	
		mm	inch	mm	inch
Overall Length	L	330	13.0	340	13.4
Overall Width	W	265	10.4	275	10.8
Overall Thickness	H	50	1.97	60	2.4
Quantity/Box	2000PCS				

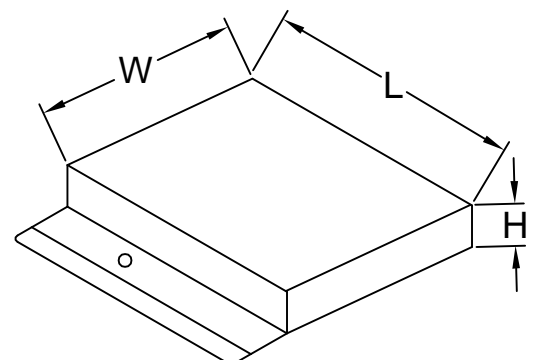

**Reliability Test:**

Test Item	Test Condition	Description	Reference Standard
Operating Life Test	1.Under Room Temperature 2.If=20mA 3.t=1000 hrs (-24hrs, +72hrs)	This test is conducted for the purpose of determining the resistance of a part in electrical and thermal stressed.	MIL-STD-750: 1026 MIL-STD-883: 1005 JIS C 7021: B-1
High Temperature Storage Test	1.Ta=85°C±5°C 2.t=1000 hrs (-24hrs, +72hrs)	The purpose of this is the resistance of the device which is laid under condition of high temperature for hours.	MIL-STD-883:1008 JIS C 7021: B-10
Low Temperature Storage Test	1.Ta=-40°C±5°C 2.t=1000 hrs (-24hrs, +72hrs)	The purpose of this is the resistance of the device which is laid under condition of low temperature for hours.	JIS C 7021: B-12
High Temperature High Humidity Test	1.Ta=65°C±5°C 2.RH=90%~95% 3.t=240hrs ±2hrs	The purpose of this test is the resistance of the device under tropical for hours.	MIL-STD-202:103B JIS C 7021: B-11
Thermal Shock Test	1.Ta=105°C±5°C & -40°C±5°C (10min) (10min) 2.total 10 cycles	The purpose of this is the resistance of the device to sudden extreme changes in high and low temperature.	MIL-STD-202: 107D MIL-STD-750: 1051 MIL-STD-883: 1011
Solder Resistance Test	1.T.Sol=260°C±5°C 2.Dwell time= 10±1sec.	This test intended to determine the thermal characteristic resistance of the device to sudden exposures at extreme changes in temperature when soldering the lead wire.	MIL-STD-202: 210A MIL-STD-750: 2031 JIS C 7021: A-1
Solderability Test	1.T.Sol=230°C±5°C 2.Dwell time=5±1sec	This test intended to see soldering well performed or not.	MIL-STD-202: 208D MIL-STD-750: 2026 MIL-STD-883: 2003 JIS C 7021: A-2