



SP1938 DC-DC Step-Up Converter for White LED

DESCRIPTION

The SP1938 is a step-up DC/DC converter for white LED driver with over voltage protection. The device can driver one to four LEDs in series from a single cell Lithium Ion battery.

Internal functions include current limiting; thermal shutdown; OVP and soft-start to prevent damage operate status. The SP1938 operates at 0.8MHz and from low input voltages as low as 1.5V; apply to Lithium-Ion powered systems. A low 95mV reference voltage minimizes power loss in the current setting resistor for better efficiency.

The SP1938 is available in small package SOT-23-6L.

APPLICATIONS

- Battery Power Equipment
- Notebook Computers
- PDA
- Cellular Phone

FEATURES

- Current Source with Over Voltage Protection
- Fast 0.8MHz Switching Frequency
- High Efficiency up to 87%
- Drives up to Four LEDs From 3.2V Supply
- Drives up to Six LEDs From a 5V Supply
- Low Quiescent Current
- Disconnects LEDs in Shutdown Mode
- Internal Over Temperature and Current Limiting Shutdown Function
- Internal Soft-Start Circuit
- 36V Rugged Bipolar Switch
- ◆ Available in a Small SOT-23-6L Package

PIN CONFIGURATION(SOT-23-6L)

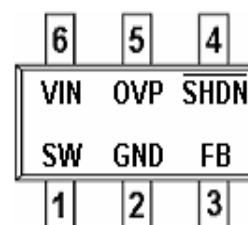

PART MARKING

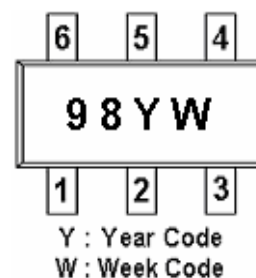



SP1938 DC-DC Step-Up Converter for White LED

TYPICAL APPLICATION CIRCUIT

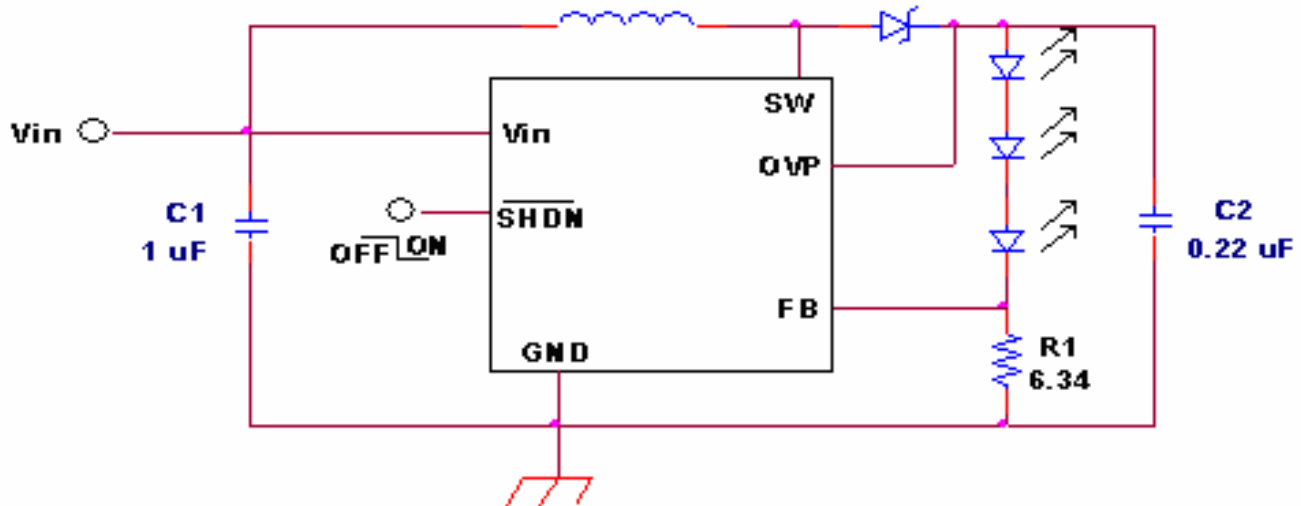

PIN DESCRIPTION

Pin	Symbol	Description
1	SW	Connect inductor/diode here
2	GND	Ground Pin
3	FB	Connect cathode of lowest LED and resistor here
4	SHDN	Combined active low enable and PWM control pin for LED dimming
5	OVP	Over voltage Protection and Connect to the output capacitor of the Converter
6	VIN	Supply Voltage Input

ORDERING INFORMATION

Part Number	Package	Part Marking
SP1938S26RGB	SOT-23-6L	98YW

- ※ Week Code : A ~ Z (1 ~ 26) ; a ~ z (27 ~ 52)
- ※ SP1938S26RGB : Tape Reel ; Pb – Free ; Halogen -Free



SP1938 DC-DC Step-Up Converter for White LED

BLOCK DIAGRAM

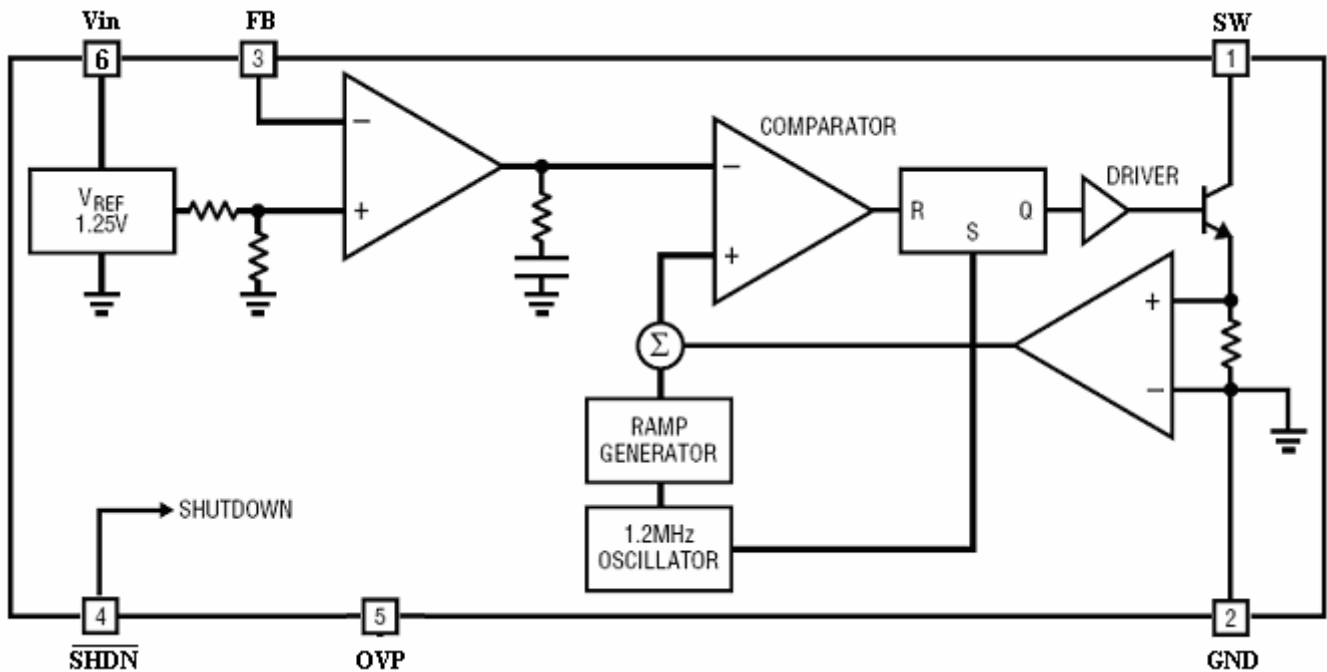

ABSOLUTE MAXIMUM RATINGS

($T_A=25^\circ\text{C}$ Unless otherwise specified)

Parameter	Symbol	Value	Unit
DC Supply Voltage	V_{IN}	18	V
SW Voltage	V_{SW}	36	V
FB Voltage	V_{FB}	7	V
SHDN Voltage	V_{SHDN}	7	V
Operating Temperature	T_{OPR}	-40~85	$^\circ\text{C}$
Maximum Junction Temperature	$T_{J(Max)}$	125	$^\circ\text{C}$
Storage Temperature	T_S	-65~150	$^\circ\text{C}$

The IC has a protection circuit against static electricity. Do not apply high static electricity or high voltage that exceeds the performance of the protection circuit to the IC.



SP1938 DC-DC Step-Up Converter for White LED

ELECTRICAL CHARACTERISTICS

($T_A=25^{\circ}\text{C}$, $V_{IN}=3\text{V}$, $V_{SHDN}=3\text{V}$, Unless otherwise specified)

Parameter	Conditions	Min.	Typ.	Max.	Unit
Operating Voltage		2.5		18	V
Feedback Voltage	$I_{sw}=100\text{mA}$, Duty Cycle = 66%	86		110	%
FB Pin Bias Current				150	nA
Supply Current			2.8	3.5	mA
	$V_{SHDN} = 0\text{V}$		0.1	1.0	μA
Switching Frequency		0.8	1.2	1.6	MHz
Maximum Duty Cycle			85		%
Switch Current Limit			320		mA
Switch Leakage Current	$V_{sw} = 5\text{V}$		0.01	5	μA
Switch Saturation Voltage	$I_{sw} = 200\text{mA}$		150		mV
SHDN Voltage High		1.5			V
SHDN Voltage Low				0.4	V
SHDN Pin Current			90		μA
Over Voltage Protection	V_{OUT} rising		21		V

APPLICATION CIRCUIT

Li-Ion to Five White LEDs

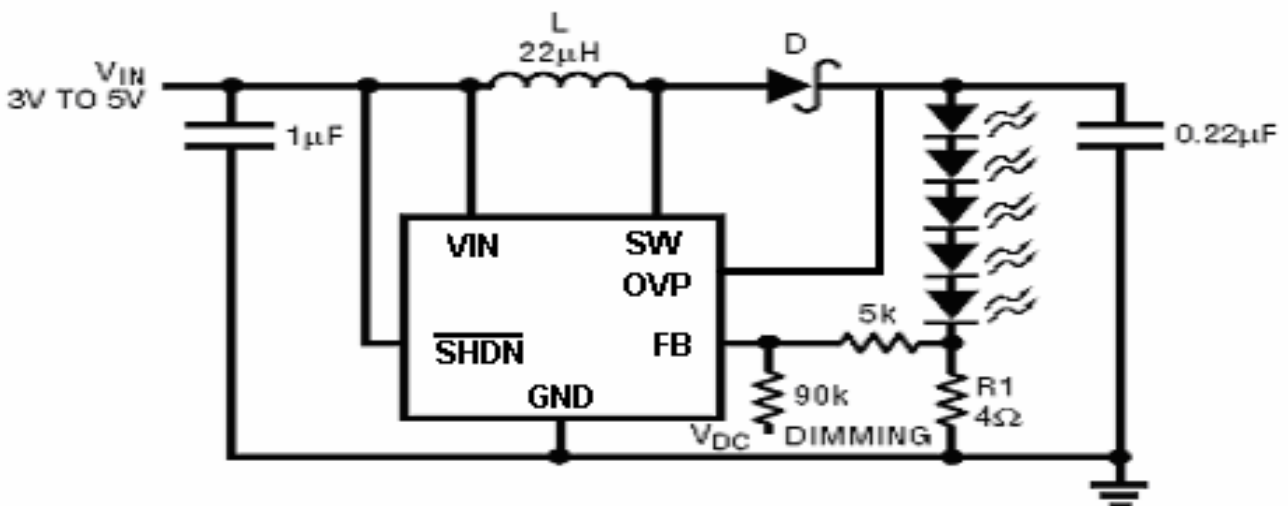



SP1938 DC-DC Step-Up Converter for White LED

SOT-23-6L PACKAGE OUTLINE

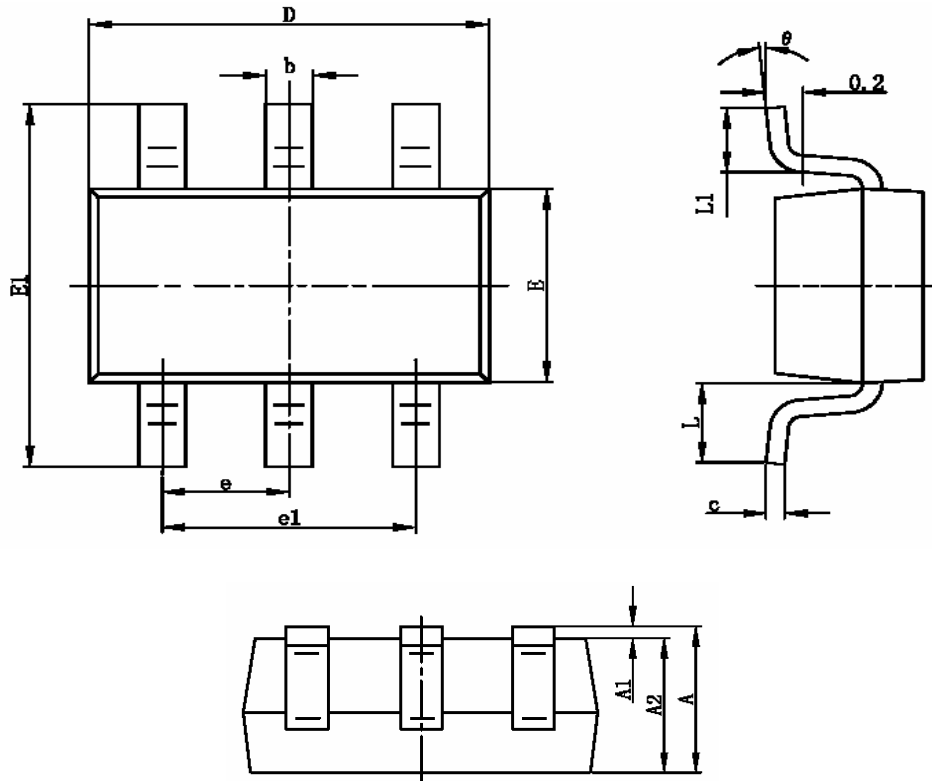

Symbol	Dimensions In Millimeters		Dimensions In Inches	
	Min	Max	Min	Max
A	1.050	1.250	0.041	0.049
A1	0.000	0.100	0.000	0.004
A2	1.050	1.150	0.041	0.045
b	0.300	0.400	0.012	0.016
c	0.100	0.200	0.004	0.008
D	2.820	3.020	0.111	0.119
E	1.500	1.700	0.059	0.067
E1	2.650	2.950	0.104	0.116
e	0.950TYP		0.037TYP	
e1	1.800	2.000	0.071	0.079
L	0.700REF		0.028REF	
L1	0.300	0.600	0.012	0.024
θ	0°	8°	0°	8°



SP1938

DC-DC Step-Up Converter for White LED

Information provided is alleged to be exact and consistent. SYNC Power Corporation presumes no responsibility for the penalties of use of such information or for any violation of patents or other rights of third parties which may result from its use. No license is granted by allegation or otherwise under any patent or patent rights of SYNC Power Corporation. Conditions mentioned in this publication are subject to change without notice. This publication surpasses and replaces all information previously supplied. SYNC Power Corporation products are not authorized for use as critical components in life support devices or systems without express written approval of SYNC Power Corporation.

©The SYNC Power logo is a registered trademark of SYNC Power Corporation

©2004 SYNC Power Corporation – Printed in Taiwan – All Rights Reserved

SYNC Power Corporation

7F-2, No.3-1, Park Street

NanKang District (NKSP), Taipei, Taiwan 115

Phone: 886-2-2655-8178

Fax: 886-2-2655-8468

<http://www.syncpower.com>
