

ITS 3100 (F) and ITS 4100 (F) Front Panel Mount Square Flange Receptacle Assembly with Class A IT3057 Cable Clamp and Neoprene Bushing

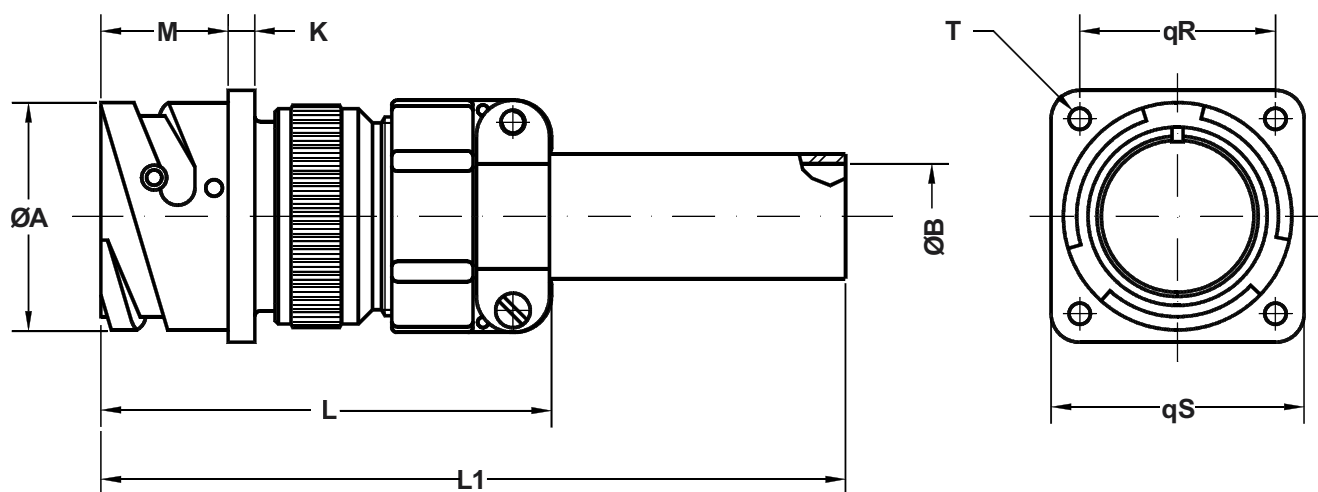

Application Notes:

1. Front panel mount square flange receptacle assembly with an insulating grommet, environmental backshell, class A IT3057 cable clamp for use with individual wires and neoprene bushing. Through mounting holes.
2. Environmental class "F" (environmental)—Wire sealing grommet supplied.
3. Standard materials configuration consists of aluminum alloy cadmium olive drab finish.
4. Standard contact material consists of copper alloy with silver plating (Gold plating available, see mod codes).
5. A broad range of additional connector accessories are available. See our website and/or contact the factory for complete information.
6. Standard insert material is synthetic rubber. Add "FR" prefix to front of part number to specify fire resistant inserts.

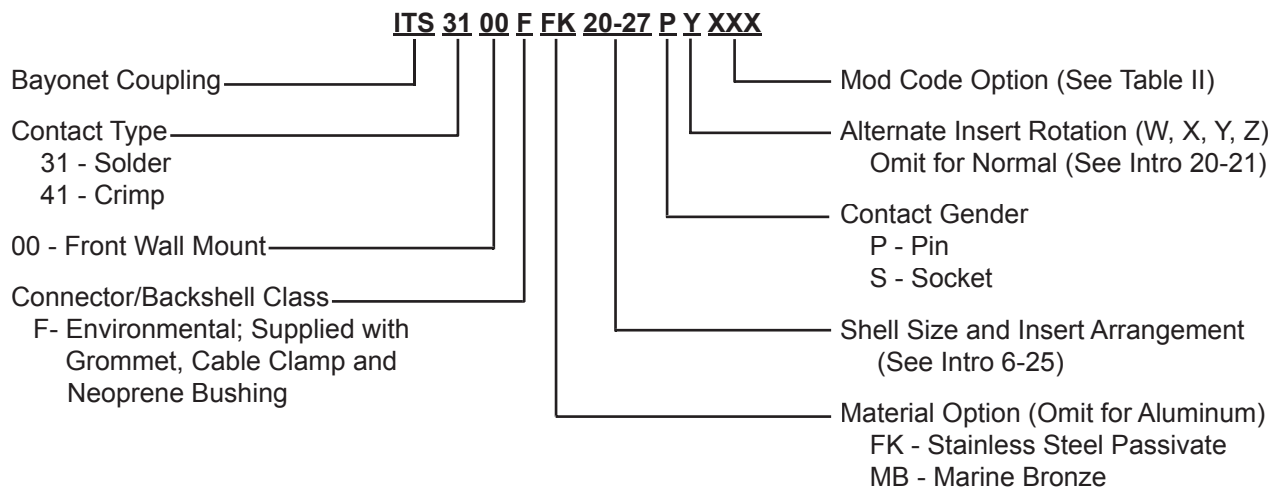

ITS 3100 (F) and ITS 4100 (F)
Front Panel Mount Square Flange Receptacle Assembly
with Class A IT3057 Cable Clamp and Neoprene Bushing



TABLE I: DIMENSIONS

Shell Size	ØA +0 -0.1	ØB ±0.1	K ±0.2	L Max.	L1 Max.	M +0.2 -0	R ±0.1	S +0.2	ØT +0.1 -0
10 SL	18.2	5.58	2.8	55.0	125	14.3	18.25	25.4	3.2
14 S	24.5	7.92	3.3	58.4	125	14.5	23.00	30.4	3.2
16 S	27.2	11.09	3.3	60.4	125	14.5	24.60	32.5	3.2
16	27.2	11.09	3.3	71.8	135	19.1	24.60	32.5	3.2
18	30.7	14.27	4.0	77.8	140	19.1	27.00	35.0	3.2
20	34.0	15.87	4.0	74.0	130	19.1	29.40	38.0	3.2
22	37.3	15.87	4.0	74.0	130	19.6	31.75	41.0	3.2
24	40.9	19.05	4.0	76.7	130	20.6	34.90	44.5	3.7
28	46.7	19.05	4.0	83.2	135	20.7	39.70	50.9	3.7
32	53.4	23.79	4.0	90.3	140	22.3	44.45	57.0	4.3
36	59.6	31.75	4.0	96.8	145	22.3	49.20	63.5	4.3
40	65.5	34.92	4.0	115.8	160	22.3	55.55	69.9	4.3

TABLE II: MODIFICATION CODES

CONTACT OPTIONS	
Sym	Description
B0	Connector Less Contacts
B1	Connector with Gold Plated Contacts
Omit for Standard Version (Silver Plated)	
FINISH OPTIONS	
Sym	Description
F2	Bright Nickel Plating
F6	Black Electrodeposited Paint
F7	Black Zn-Co Plating
F8	Olive Drab Zn-Co Plating
Omit for Standard Version (Cad/Olive Drab Finish)	

