



PLX Technology Acquired Oxford Semiconductor in January 2009

This document is not yet formatted to PLX style

For more information, please visit our Website

Website: www.plxtech.com

Sales: www.plxtech.com/sales

Technical Support: www.plxtech.com/support



OXuPCI954

Universal PCI bridge to quad serial and parallel port

Description

Part of Oxford Semiconductor's family of high performance serial connectivity solutions, the OXuPCI954 is a single chip, dual serial and parallel port solution for universal PCI based connectivity.

Incorporating Oxford Semiconductor's ultra high performance 950 UART technology, it combines outstanding system performance with unrivalled flexibility for even the most demanding of serial applications.

Complete with development tools and certified device drivers, effectively reducing design cycles and accelerating time to market, the OXuPCI954 is the ideal connectivity solution for a diverse range of products including: PC Add-on Cards, Industrial PC, Point of Sale Terminals, Industrial Control, Building Automation and Network Management.



Features

- 3.3V or 5V operation
- 4 high performance UARTs with peak asynchronous data rates up to 15Mbps
- RS232/422/485 full and half duplex interfaces
- Deep 128-Byte receive/transmit FIFOs
- Full modem interface with hardware out of band flow control
- Programmable RS485 turnaround delay
- Automated Xon/Xoff in-band flow control
- Flexible clock prescaler allows for a wide range of baud rates
- Infra-red (IrDA) receive and transmit operation
- IEEE 1284 compliant SPP, EPP and ECP parallel port
- 8 bit pass-through local bus for port expansion
- 11 GPIOs
- PCI 3.0 and Power Management 1.1 compliant
- Software compatible with industry standard 16C550 type devices
- 176 LQFP package
- Industrial temperature range (-40 to +85°C)
- Certified device drivers for a wide range of operating systems including Windows Vista/XP and Linux



Outstanding Performance

The OXuPCI954 integrates four ultra high performance Oxford 950 UARTs that combine class leading 15Mbps asynchronous data rates and the industry's deepest FIFOs, for maximum throughput, minimum CPU overhead and optimal system performance. Advanced features of the device, such as automated in-band flow control, readable FIFO levels and RS485 turnaround delay, provide further scope to fine tune performance, while the flexible clock pre-scaler provides a wide range of baud rates.

To support these advanced features the OXuPCI954 is backed by a dedicated Oxford device driver that is quality assured, exhaustively tested and WHQL approved; saving development time and providing peace of mind.

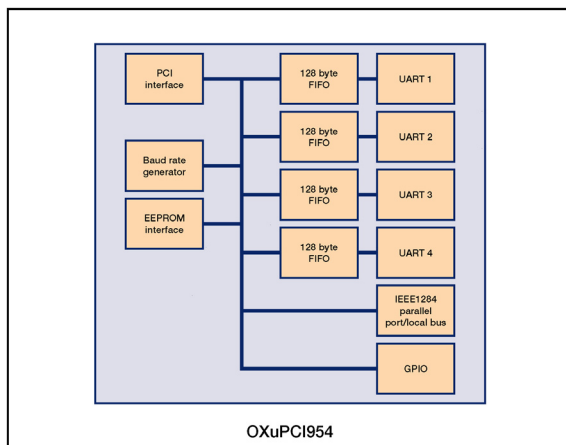

Contact details

Sales email: sales@oxsemi.com

Web: www.oxsemi.com



Development environment

The OXuPCI954 evaluation kit supports rapid evaluation and design for accelerated time to market.

Central to this is the short form PCI evaluation board; plugged into any PCI card slot it provides access to all aspects of the device. But, it doesn't stop there; the kit has everything needed for PC installation and evaluation including cables, expansion brackets and Oxford's device drivers.

The inclusion of OXide, Oxford's Windows compatible development tool, makes device configuration and management fast and easy.

Evaluation kit contents

- OXuPCI954 evaluation board
- OXuPCI954 chip samples x 2
- 4-way serial breakout cables x 2
- Parallel port expansion bracket
- Evaluation CD including:
 - OXide
 - Device Drivers
 - Documentation