

## GLASS PASSIVATED BRIDGE RECTIFIERS

REVERSE VOLTAGE - 50 to 1000Volts  
FORWARD CURRENT - 8.0 Amperes

### FEATURES

- Surge overload rating -175 amperes peak
- Low forward voltage drop
- Small size; simple installation
- Silver plated copper leads
- Mounting position: Any

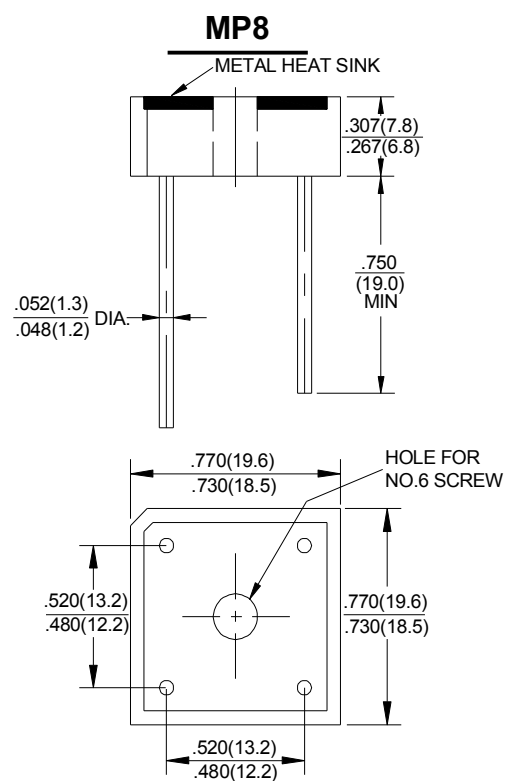

Polarity shown on side of case, Positive lead by beveled corner.

Dimensions in inches and (millimeters)

## MAXIMUM RATINGS AND ELECTRICAL CHARACTERISTICS

Rating at 25°C ambient temperature unless otherwise specified.

Single phase, half wave ,60Hz, resistive or inductive load.

For capacitive load, derate current by 20%

CHARACTERISTICS	SYMBOL	MP8005G	MP801G	MP802G	MP804G	MP806G	MP808G	MP810G	UNIT
Maximum Recurrent Peak Reverse Voltage	V <sub>RRM</sub>	50	100	200	400	600	800	1000	V
Maximum RMS Bridge Input Voltage	V <sub>RMS</sub>	35	70	140	280	420	560	700	V
Maximum Average Forward Rectified Output Current at T <sub>A</sub> =50°C	I <sub(av)< sub=""></sub(av)<>	8.0							A
Peak Forward Surge Current 8.3ms Single Half Sine-Wave Super Imposed on Rated Load	I <sub>FSM</sub>	175							A
Maximum Forward Voltage Drop Per Bridge Element at 4.0A Peak	V <sub>F</sub>	1.1							V
Maximum Reverse Current at Rated T <sub>J</sub> =25°C	I <sub>R</sub>	10.0							μA
DC Blocking Voltage Per Element T <sub>J</sub> =100°C		1.0							mA
Operating Temperature Range	T <sub>J</sub>	-55 to +150							°C
Storage Temperature Range	T <sub>STG</sub>	-55 to +150							°C

FIG.1-DERATING CURVE FOR  
 OUTPUT RECTIFIED CURRENT

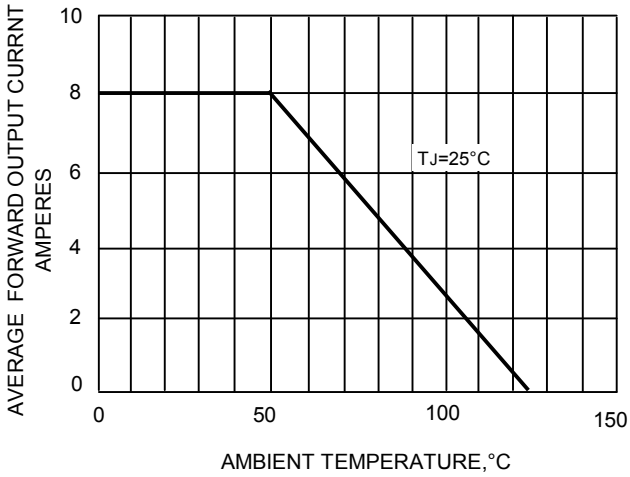

FIG.2-MAXIMUM FORWARD SURGE CURRENT

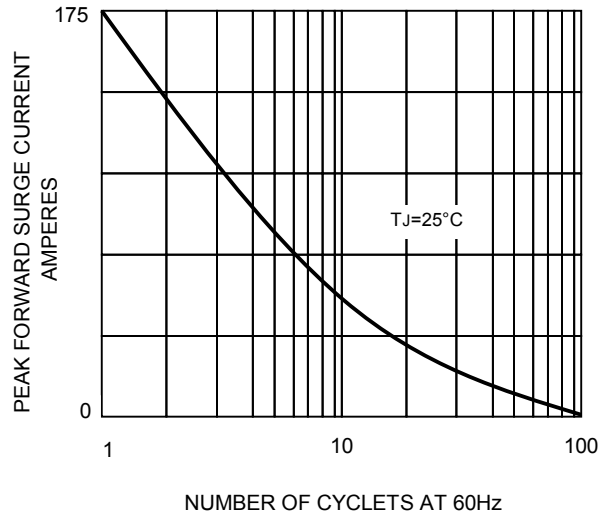

FIG.3-TYPICAL FORWARD  
 CHARACTERISTICS

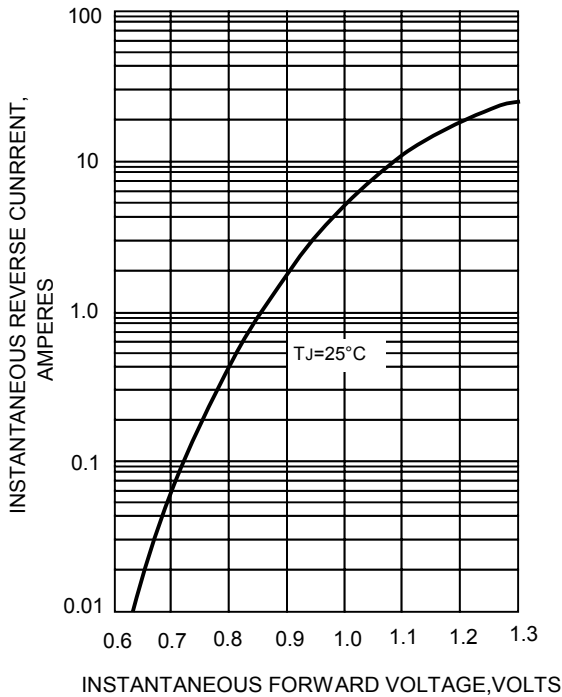

FIG.4-TYPICAL REVERSE  
 CHARACTERISTICS

