

Features

- 802.11a + b/g Dual Band Applications
- Broadband Performance: DC - 6.0 GHz
- Low Insertion Loss: 0.7 dB @ 2.4 GHz
1.0 dB @ 4.9 to 6.0 GHz
- High Isolation: 43 dB @ 2.4 GHz
30 dB @ 4.9 to 6.0 GHz
- Fast Switching Speed: 0.5 μ m GaAs PHEMT
- Low Cost 3 mm 12-Lead PQFN Package
- Lead-Free Package Available: MASWSS0129
- Known Good Die Available

Description

M/A-COM's MASWSS0094 is a broadband GaAs PHEMT MMIC diversity switch available in a low cost 3 mm 12-lead PQFN package or as known good die. The MASWSS0094 is ideally suited for applications where very small size and low cost are required.

Typical applications are for WLAN IEEE 802.11a and 802.11b/g systems that employ two antennas for transmit and receive diversity. Other applications include cordless phones and base stations. Designed for high power, this DPDT switch maintains high linearity up to 6.0 GHz.

The MASWSS0094 is fabricated using a 0.5 micron gate length GaAs PHEMT process. The process features full passivation for performance and reliability.

Ordering Information ¹

Part Number	Package
MASWSS0094	Bulk Packaging
MASWSS0094TR	7 inch, 1000 piece reel
MASWSS0094TR-3000	13 inch, 3000 piece reel
MASWSS0094SMB	Sample Test Board (Includes 5 Samples)
MASWSS0094-DIE	Separated Die on Grip Ring ²

1. Reference Application Note M513 for reel size information.
2. Die quantity varies.

Functional Schematic

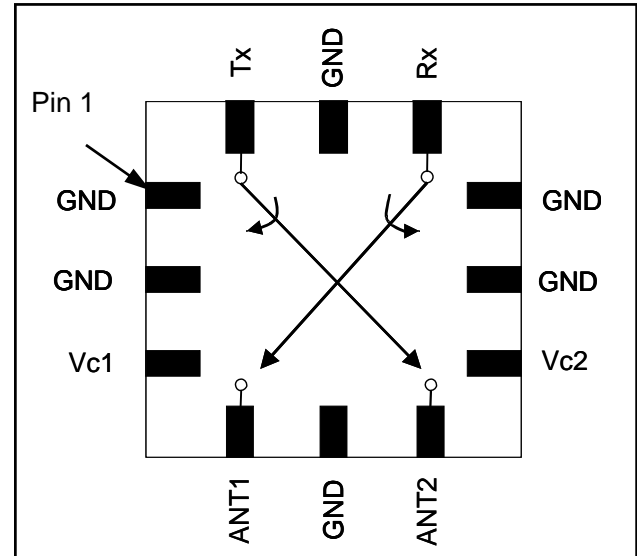

Pin Configuration

3 mm 12-Lead PQFN Package

Pin No.	Pin Name	Description
1	GND	Ground
2	GND	Ground
3	V _{C1}	Control 1
4	ANT1	Antenna Port 1
5	GND	Ground
6	ANT2	Antenna Port 2
7	V _{C2}	Control 2
8	GND	Ground
9	GND	Ground
10	Rx	Receive Port
11	GND	Ground
12	Tx	Transmit Port
13	Paddle ³	RF and DC Ground

3. The exposed pad centered on the package bottom must be connected to RF and DC ground.

GaAs Broadband DPDT Diversity Switch DC - 6.0 GHz

Rev. V6

Electrical Specifications: $T_A = 25^\circ\text{C}$, $Z_0 = 50\Omega$, $V_C = 0\text{ V} / 3\text{ V}$, 8 pF Capacitor⁴

Parameter	Test Conditions	Units	Min.	Typ.	Max.
Insertion Loss ⁵	2.4 GHz	dB	—	0.70	1.30
	2 - 4 GHz	dB	—	0.75	—
	4 - 5 GHz	dB	—	0.90	—
	4.9 - 6 GHz	dB	—	1.00	1.55
Isolation ⁶ (on/off or off/on)	2.4 GHz	dB	—	43	—
	4.9 - 6 GHz	dB	25	30	—
Isolation (on/on or off/off)	2.4 GHz	dB	—	11	—
	4.9 - 6 GHz	dB	—	20	—
Return Loss	2.4 GHz	dB	—	23	—
	4.9 - 6 GHz	dB	—	15	—
IP2	Two Tone, +15 dBm/Tone, 5 MHz Spacing, > 50 MHz				
	2.4 GHz	dBm	—	93	—
	5.3 GHz	dBm	—	86	—
IP3	Two Tone, +15 dBm/Tone, 5 MHz Spacing, > 50 MHz				
	2.4 GHz	dBm	—	52	—
	5.3 GHz	dBm	—	50	—
Input P-1dB	2.4 GHz	dBm	—	33	—
	5.3 GHz	dBm	—	31	—
	5.8 GHz	dBm	—	31	—
2 nd Harmonic	2.4 GHz, Pin = +20 dBm	dBc	—	-75	—
	5.8 GHz, Pin = +20 dBm	dBc	—	-77	—
3 rd Harmonic	2.4 GHz, Pin = +20 dBm	dBc	—	-69	—
	5.8 GHz, Pin = +20 dBm	dBc	—	-86	—
Trise, Tfall	10% to 90% RF	nS	—	35	—
	90% to 10% RF	nS	—	60	—
Ton, Toff	50% control to 90% RF, and 50% control to 10% RF	nS	—	90	—
Transients		mV	—	6	—
Control Current	Vc = 3 V	μA	—	6	25

4. For positive voltage control, external DC blocking capacitors are required on all RF ports.

5. Insertion loss can be optimized by varying the DC blocking capacitor value.

6. Isolation minimum specification guaranteed in final package assembly only.

Evaluation Board for 3 mm 12-Lead PQFN Package

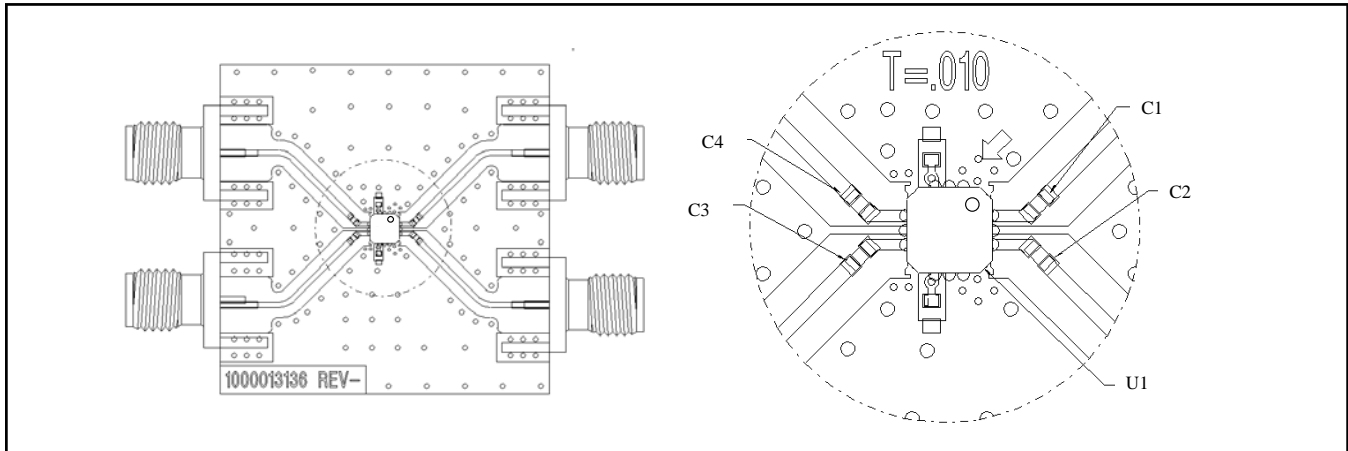

Application Schematic

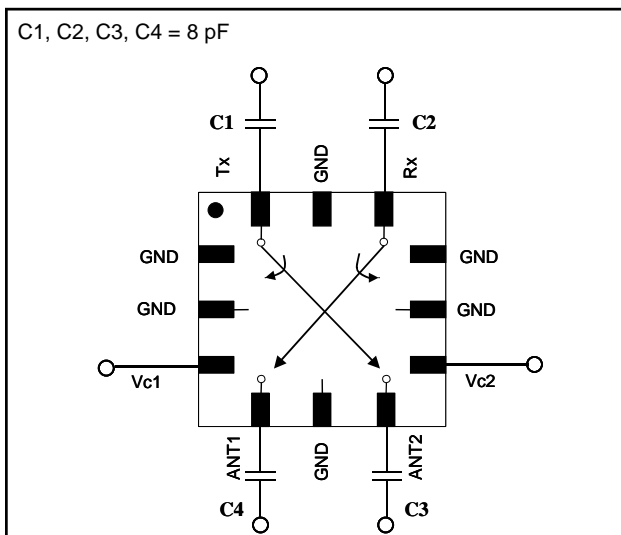

Truth Table ^{9,10}

Control V _{c1}	Control V _{c2}	ANT 1 - Rx	ANT 1 - Tx	ANT 2 - Tx	ANT 2 - Rx
1	0	On	Off	On	Off
0	1	Off	On	Off	On
1	1	Off	Off	Off	Off
0	0	Off	Off	Off	Off

9. 1 = +2.9 V to +5 V, 0 = 0 V ± 0.2 V.

10. Differential voltage, V(state 1) - V(state 0), must be 2.7 V minimum and must not exceed 8.5 V.

Handling Procedures

Please observe the following precautions to avoid damage:

Static Sensitivity

Gallium Arsenide Integrated Circuits are sensitive to electrostatic discharge (ESD) and can be damaged by static electricity. Proper ESD control techniques should be used when handling these devices.

Absolute Maximum Ratings ^{7,8}

Parameter	Absolute Maximum
Input Power @ 3 V Control	+31 dBm
Input Power @ 5 V Control	+34 dBm
Voltage	±8.5 volts
Operating Temperature	-40°C to +85°C
Storage Temperature	-65°C to +150°C

7. Exceeding any one or combination of these limits may cause permanent damage to this device.

8. M/A-COM does not recommend sustained operation near these survivability limits.

Typical Performance Curves, 8 pF Blocking Caps

Insertion Loss

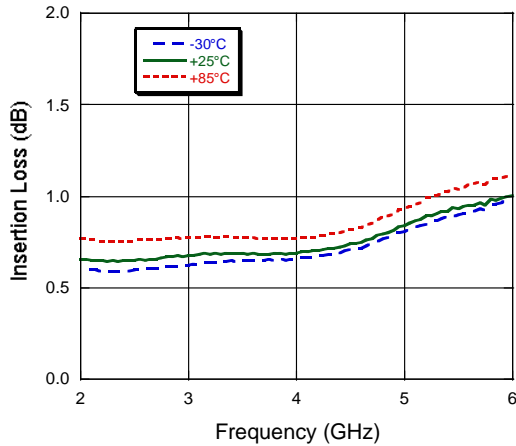

Isolation

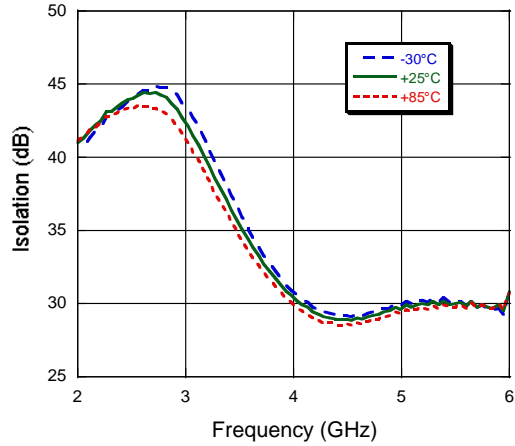

Antenna Ports Return Loss

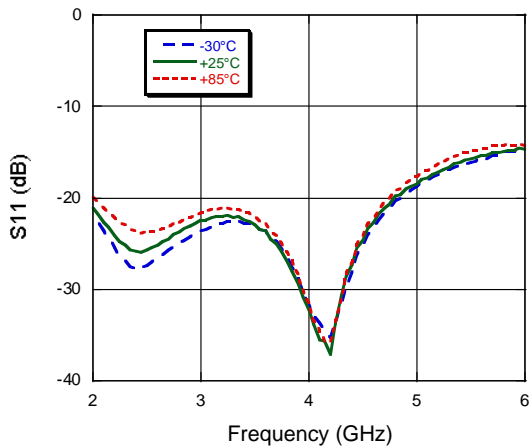

Tx/Rx Ports Return Loss

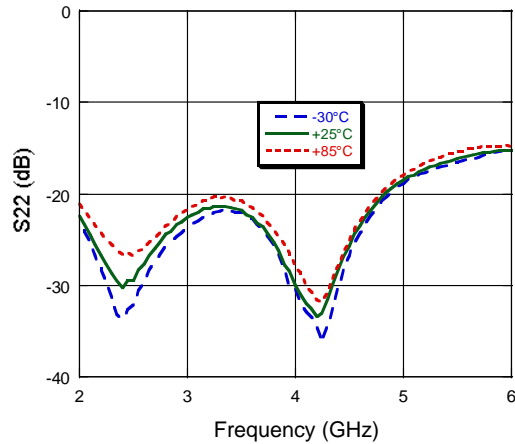

GaAs Broadband DPDT Diversity Switch DC - 6.0 GHz

Rev. V6

3 mm 12-Lead PQFN

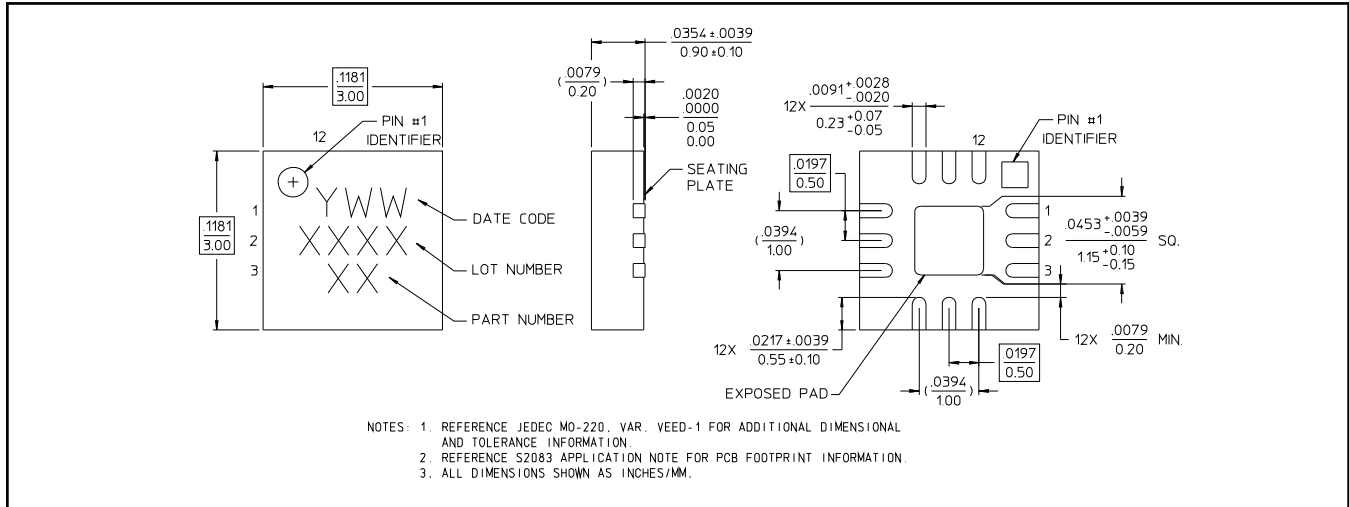

MASWSS0094-DIE Die Bond Pad Layout

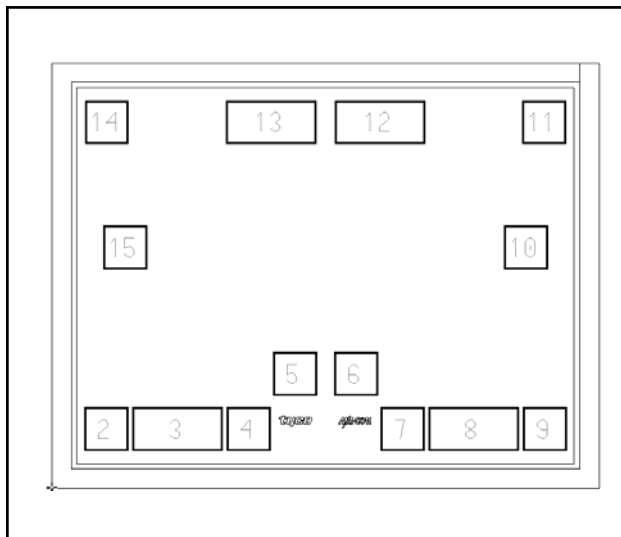

Die Bond Pad Configuration

Pad No.	Name	Description
2	V _{C1}	Control 1
3	GND	Ground
4	N/C	No Connection
5	ANT1	Antenna Port 1
6	ANT2	Antenna Port 2
7	N/C	No Connection
8	GND	Ground
9	V _{C2}	Control 2
10	Rx	Receive Port
11	N/C	No Connection
12	GND	Ground
13	GND	Ground
14	N/C	No Connection
15	TX	Transmit Port