

**CONNECTOR
DESIGNATORS**

**A-F-H-L-S
ROTATABLE
COUPLING**

**TYPE D INDIVIDUAL
OR OVERALL
SHIELD TERMINATION**

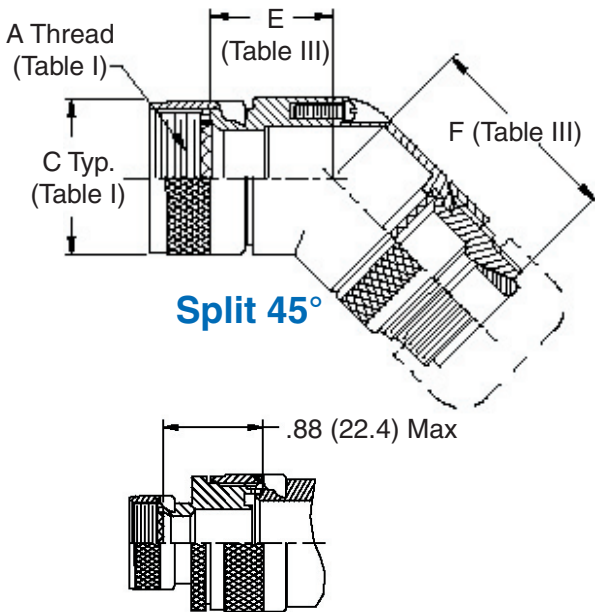
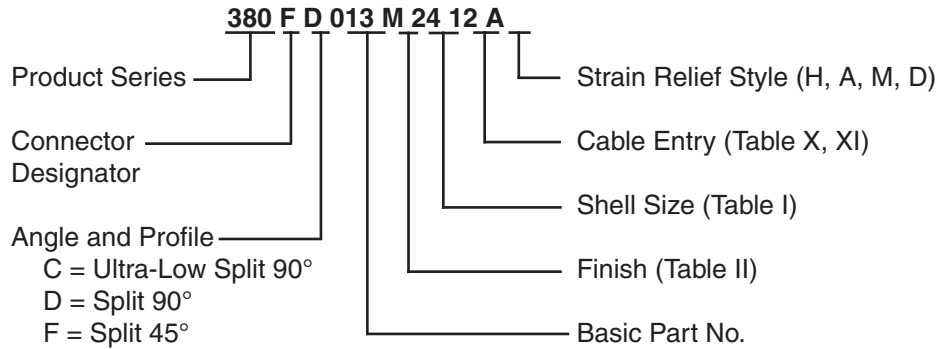

STYLE 2
(See Note 1)

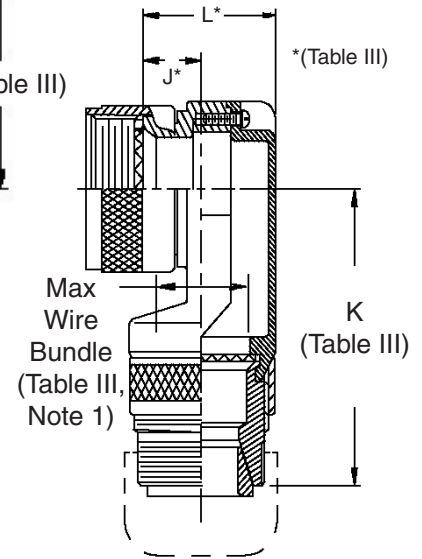
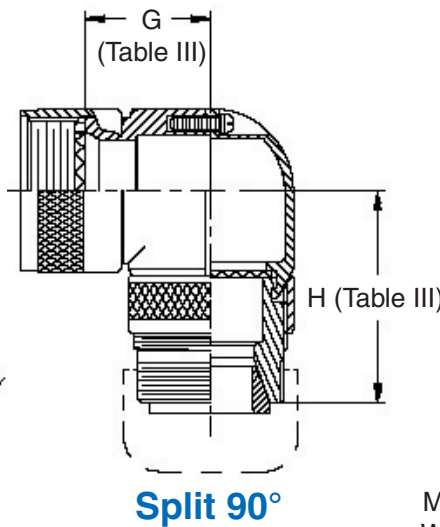

**Ultra Low-Profile
Split 90°**

STYLE H
Heavy Duty
(Table X)

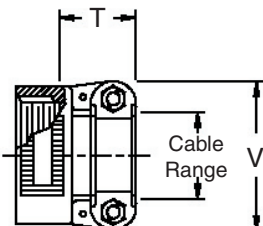

STYLE A
Medium Duty
(Table XI)

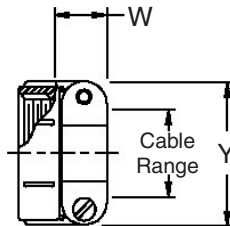

STYLE M
Medium Duty
(Table XI)

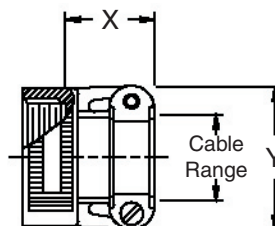

STYLE D
Medium Duty
(Table XI)

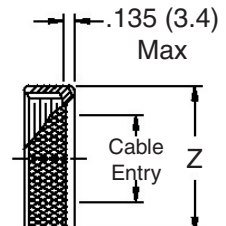

See inside back cover fold-out or pages 13 and 14 for unabridged Tables I and II.

TABLE III: DIMENSIONS

Shell Size	E Max	F Max	G Max	H Max	J Ref	K Max	L Max	Function C Max Wire Bundle
08/09	.440 (11.2)	1.730 (43.9)	.680 (17.3)	1.670 (42.4)	.340 (8.6)	1.920 (48.8)	.681 (17.3)	.250 (6.4)
10/11	.500 (12.7)	1.785 (45.3)	.750 (19.1)	1.725 (43.8)	.270 (6.9)	2.080 (52.8)	.731 (18.6)	.375 (9.5)
12/13	.560 (14.2)	1.855 (47.1)	.810 (20.6)	1.795 (45.6)	.270 (6.9)	2.080 (52.8)	.731 (18.6)	.375 (9.5)
14/15	.620 (15.7)	1.887 (47.9)	.870 (22.1)	1.827 (46.4)	.320 (8.1)	2.150 (54.6)	.831 (21.1)	.500 (12.7)
16/17	.680 (17.3)	1.987 (50.5)	.930 (23.6)	1.927 (48.9)	.420 (10.7)	2.200 (55.9)	.981 (24.9)	.625 (15.9)
18/19	.750 (19.1)	2.045 (51.9)	1.000 (25.4)	1.985 (50.4)	.640 (16.3)	2.230 (56.6)	1.181 (30.0)	.625 (15.9)
20/21	.820 (20.8)	2.106 (53.5)	1.060 (26.9)	2.046 (52.0)	.640 (16.3)	2.230 (56.6)	1.181 (30.0)	.625 (15.9)
22/23	.880 (22.4)	2.167 (55.0)	1.120 (28.4)	2.107 (53.5)	.540 (13.7)	2.380 (60.5)	1.181 (30.0)	.750 (19.1)
24/25	.940 (23.9)	2.225 (56.5)	1.180 (30.0)	2.165 (55.0)	.540 (13.7)	2.380 (60.5)	1.181 (30.0)	.750 (19.1)

TABLE X: CABLE ENTRY

Dash No.	T Max	V Max	Cable Range	
			Min	Max
04	.780 (19.8)	.957 (24.3)	.125 (3.2)	.312 (7.9)
06	.780 (19.8)	1.145 (29.1)	.250 (6.4)	.437 (11.1)
08	.780 (19.8)	1.332 (33.8)	.312 (7.9)	.562 (14.3)
10	.780 (19.8)	1.332 (33.8)	.350 (8.9)	.625 (15.9)
12	.811 (20.6)	1.551 (39.4)	.500 (12.7)	.750 (19.1)
16	.905 (23.0)	1.770 (45.0)	.625 (15.9)	.937 (23.8)
20	1.092 (27.7)	2.113 (53.7)	.875 (22.2)	1.250 (31.8)
24	1.124 (28.5)	2.363 (60.0)	1.000 (25.4)	1.375 (34.9)
28	1.399 (35.5)	2.770 (70.4)	1.250 (31.8)	1.625 (41.3)
32	1.399 (35.5)	3.020 (76.7)	1.437 (36.5)	1.875 (47.6)

TABLE II: STANDARD FINISHES

GLENAIR	
SYMBOL	FINISH
B	Cadmium Plate, Olive Drab
M	Electroless Nickel
NF	Cadmium Plate, Olive Drab Over Electroless Nickel
See Inside Back Cover for Additional Finish Options	

- When maximum cable entry (page 21) is exceeded, Style 2 will be supplied (not available in Function C). Dimensions E, F, G and H will not apply. Please consult factory.
- Metric dimensions (mm) are indicated in parentheses.

TABLE XI: CABLE ENTRY

Dash No.	W Max	X Max	Y Max	Z Max	Cable Range	
					Min **	Max
03*	.437 (11.1)	.760 (19.3)	.843 (21.4)	.630 (16.0)	.156 (4.0)	.250 (6.4)
04*	.437 (11.1)	.760 (19.3)	.906 (23.0)	.755 (19.2)	.188 (4.8)	.312 (7.9)
06*	.500 (12.7)	.760 (19.3)	1.093 (27.8)	.942 (23.9)	.281 (7.1)	.438 (11.1)
08	.563 (14.3)	.760 (19.3)	1.187 (30.1)	1.067 (27.1)	.344 (8.7)	.562 (14.3)
10	.563 (14.3)	.760 (19.3)	1.281 (32.5)	1.192 (30.3)	.375 (9.5)	.625 (15.9)
12	.563 (14.3)	.760 (19.3)	1.500 (38.1)	1.380 (35.1)	.438 (11.1)	.750 (19.1)
16	.656 (16.7)	1.073 (27.3)	1.719 (43.7)	1.535 (39.0)	.562 (14.3)	.938 (23.8)
20	.656 (16.7)	1.323 (33.6)	2.062 (52.4)	1.848 (46.9)	.750 (19.1)	1.250 (31.8)
24	.656 (16.7)	1.323 (33.6)	2.312 (58.7)	2.255 (57.3)	.781 (19.8)	1.375 (34.9)
28	1.188 (30.2)	1.572 (39.9)	2.719 (69.1)	2.505 (63.6)	.969 (24.6)	1.625 (41.3)
32*	1.187 (30.1)	1.572 (39.9)	2.969 (75.4)	2.755 (70.0)	1.125 (28.6)	1.875 (47.6)
40*	1.125 (28.6)	1.572 (39.9)	3.531 (89.7)	3.255 (82.7)	1.469 (37.3)	2.375 (60.3)

* Not available in Style M clamp. ** Not Applicable Style D

- Cable range is defined as the accommodations range for the wire bundle or cable. Dimensions shown are not intended for inspection criteria.
- Angular function "C", low-profile split elbow, not available with "S" connector designator.