

**512K x 8 SRAM
SRAM MEMORY ARRAY
AVAILABLE AS MILITARY
SPECIFICATION**

- SMD 5962-95600
- SMD 5962-95613
- MIL STD-883

FEATURES

- High Speed: 12, 15, 17, 20, 25, 35 and 45ns
- High-performance, low power military grade device
- Single +5V \pm 10% power supply
- Easy memory expansion with CE\ and OE\ options
- All inputs and outputs are TTL-compatible
- Ease of upgradability from 1 Meg using the 32 pin evolutionary version.

OPTIONS

- Timing
 - 12ns access
 - 15ns access
 - 17ns access
 - 20ns access
 - 25ns access
 - 35ns access
 - 45ns access
- Operating Temperature Range
 - Military: -55°C to +125°C
 - Industrial: -40°C to +85°C
- Packages
 - Ceramic Dip (600 mil)
 - Ceramic Flatpack
 - Ceramic LCC
 - Ceramic SOJ
 - Ceramic LCC (contact factory)
- Options
 - 2V data retention/ low power

MARKING

-12		
-15		
-17		
-20		
-25		
-35		
-45		
XT		
IT		
CW	No. 112	
F	No. 304	
EC	No. 209	
ECJ	No. 502	
ECA	No. 208	
L		

NOTE: Not all combinations of operating temperature, speed, data retention and low power are necessarily available. Please contact factory for availability of specific part number combinations.

GENERAL DESCRIPTION

The AS5C4008 is a 4 megabit monolithic CMOS SRAM, organized as a 512K x 8.

The evolutionary 32 pin device allows for easy upgrades from the 1 meg SRAM.

For flexibility in high-speed memory applications, ASI offers chip enable (CE\) and output enable (OE\) capabilities. These enhancements can place the outputs in High-Z for additional flexibility in system design.

Writing to these devices is accomplished when write enable (WE\) and CE\ inputs are both LOW. Reading is accomplished when WE\ remains HIGH and CE\ and OE\ go LOW. This allows systems designers to meet low standby power requirements.

All devices operate from a single +5V power supply and all inputs are fully TTL-Compatible.

**PIN ASSIGNMENT
(Top View)**

32-Pin DIP (CW), 32-Pin LCC (EC)
32-Pin SOJ (ECJ)

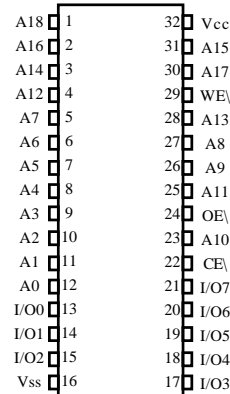

32-Pin Flat Pack (F)

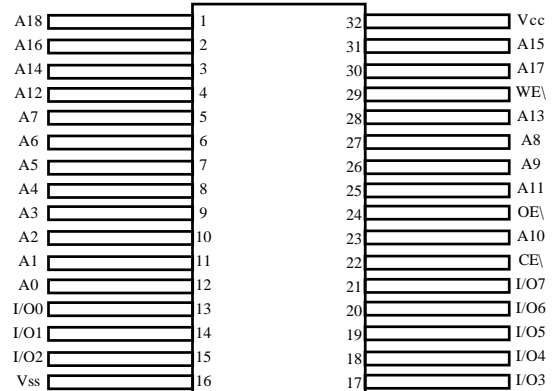

32-Pin LCC (ECA)

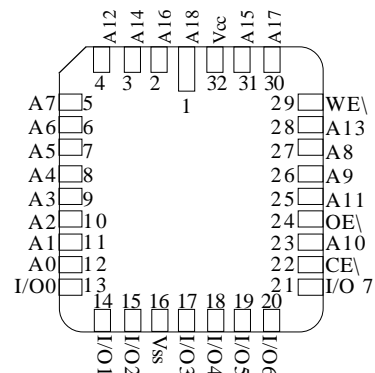

For more products and information
please visit our web site at
www.austinsemiconductor.com

FUNCTIONAL BLOCK DIAGRAM

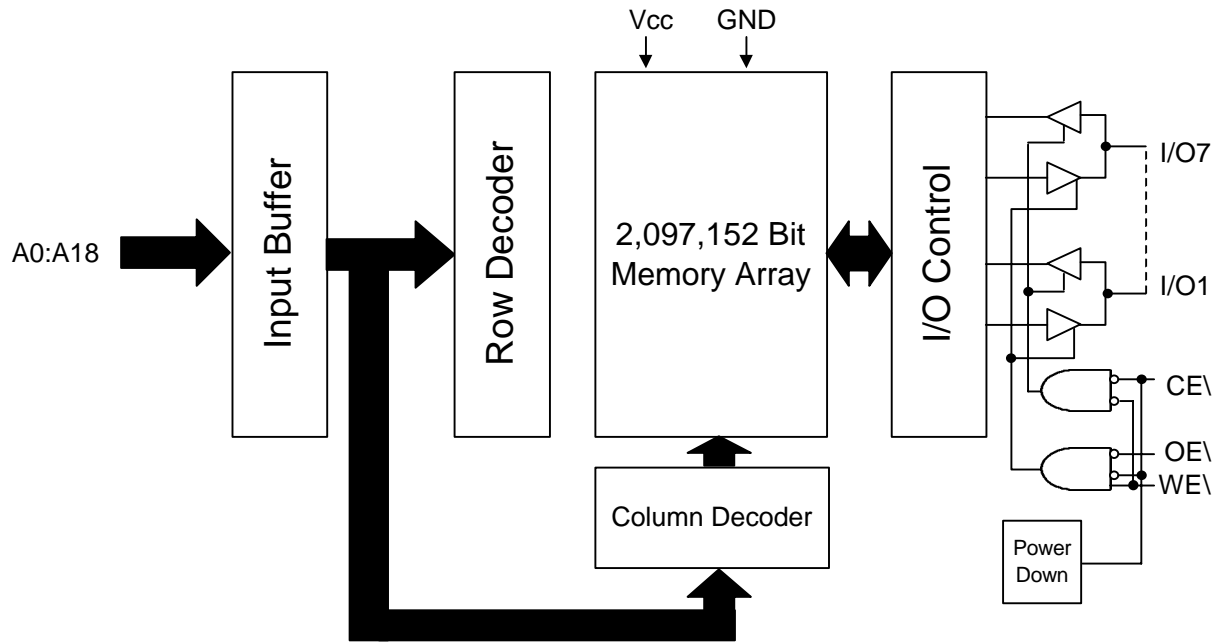

TRUTH TABLE

MODE	OE\	CE\	WE\	DQ	POWER
STANDBY	X	H	X	High-Z	STANDBY
READ	L	L	H	Q	ACTIVE
NOT SELECTED	H	L	H	High-Z	ACTIVE
WRITE	X	L	L	D	ACTIVE



ABSOLUTE MAXIMUM RATINGS*

Voltage on V_{cc} Supply Relative to V_{ss}.....-5V to +7.0V
 Storage Temperature-65°C to +150°C
 Short Circuit Output Current (per I/O).....20mA
 Voltage on any Pin Relative to V_{ss}.....-5V to V_{cc}+1 V
 Maximum Junction Temperature**+150°C

*Stresses greater than those listed under "Absolute Maximum Ratings" may cause permanent damage to the device. This is a stress rating only and functional operation of the device at these or any other conditions above those indicated in the operation section of this specification is not implied. Exposure to absolute maximum rating conditions for extended periods may affect reliability.

** Junction temperature depends upon package type, cycle time, loading, ambient temperature and airflow.

ELECTRICAL CHARACTERISTICS AND RECOMMENDED DC OPERATING CONDITIONS

(-55°C ≤ T_A ≤ 125°C or -40°C to +85°C; V_{cc} = 5V ±10%)

PARAMETER	CONDITION	SYMBOL	MIN	MAX	UNITS	NOTES
Input High (Logic 1) Voltage		V _{IH}	2.2	V _{CC} +0.5	V	1
Input Low (Logic 0) Voltage		V _{IL}	-0.5	0.8	V	1, 2
Input Leakage Current	0V ≤ V _{IN} ≤ V _{CC}	I _{L1}	-10	10	μA	
Output Leakage Current	Output(s) disabled 0V ≤ V _{OUT} ≤ V _{CC}	I _{LO}	-10	10	μA	
Output High Voltage	I _{OH} = -4.0 mA	V _{OH}	2.4	--	V	1
Output Low Voltage	I _{OL} = 8.0 mA	V _{OL}	---	0.4	V	1
Supply Voltage		V _{CC}	4.5	5.5	V	1

PARAMETER	CONDITIONS	SYM	MAX							UNITS	NOTES	
			-12	-15	-17	-20	-25	-35	-45			
Power Supply Current: Operating	CE \ ≤ V _{IL} ; V _{CC} = MAX f = MAX = 1/t _{RC} Outputs Open	I _{CCSP}	225	225	225	225	225	225	225	225	mA	3
	L Version Only	I _{CCLP}	180	180	180	180	180	180	180	180	mA	
Power Supply Current: Standby	CE \ ≥ V _{IH} ; V _{CC} = MAX f = 0, Outputs Open	I _{SBTSP}	60	60	60	60	60	60	60	60	mA	
	L Version Only	I _{SBTLP}	30	30	30	30	30	30	30	30	mA	
	CE \ ≤ V _{CC} -0.2V; V _{CC} = MAX V _{IN} ≤ V _{SS} +0.2V or V _{IN} ≥ V _{CC} -0.2V; f = 0	I _{SBCSP}	25	25	25	25	25	25	25	25	mA	
	L Version Only	I _{SBCLP}	10	10	10	10	10	10	10	10	mA	

CAPACITANCE

PARAMETER	CONDITIONS	SYMBOL	MAX	UNITS	NOTES
Input Capacitance	T _A = 25°C, f = 1MHz V _{IN} = 0	C _I	12	pF	4
Output Capacitance		C _O	14	pF	4



ELECTRICAL CHARACTERISTICS AND RECOMMENDED AC OPERATING CONDITIONS

(-55°C ≤ T_A ≤ 125°C or -40°C to +85°C; V_{CC} = 5V ±10%)

DESCRIPTION	SYM	-12		-15		-17		-20		-25		-35		-45		UNITS	NOTES
		MIN	MAX	MIN	MAX	MIN	MAX	MIN	MAX	MIN	MAX	MIN	MAX	MIN	MAX		
READ CYCLE																	
Read Cycle Time	t _{RC}	12		15		17		20		25		35		45		ns	
Address Access Time	t _{AA}		12		15		17		20		25		35		45	ns	
Chip Enable Access Time	t _{ACE}		12		15		17		20		25		35		45	ns	
Output Hold From Address Change	t _{OH}	2		2		2		2		2		2		2		ns	
Chip Enable to Output in Low-Z	t _{LZCE}	2		2		2		2		2		2		2		ns	4, 6, 7
Chip Disable to Output in High-Z	t _{HZCE}	0	6.5	0	7	0	8	0	8	0	10	0	15	0	20	ns	4, 6, 7
Output Enable Access Time	t _{AOE}		7		8		8		10		12		15		25	ns	
Output Enable to Output in Low-Z	t _{LZOE}	0		0		0		0		0		0		0		ns	4, 6, 7
Output Disable to Output in High-Z	t _{HZOE}	0	6.5	0	7	0	8	0	8	0	10	0	15	0	20	ns	4, 6, 7
WRITE CYCLE																	
WRITE Cycle Time	t _{WC}	12		15		17		20		25		35		45		ns	
Chip Enable to End of Write	t _{CW}	12		15		16		17		20		30		35		ns	
Address Valid to End of Write	t _{AW}	12		15		16		17		20		30		35		ns	
Address Setup Time	t _{AS}	0		0		0		0		0		0		0		ns	
Address Hold From End of Write	t _{AH}	1		0		1		1		1		1		1		ns	
WRITE Pulse Width	t _{WP}	12		15		16		17		20		30		35		ns	
Data Setup Time	t _{DS}	6.5		7		9		10		12		20		25		ns	
Data Hold Time	t _{DH}	0		0		0		0		0		0		0		ns	
Write Disable to Output in Low-Z	t _{LZWE}	0		0		0		0		0		0		0		ns	4, 6, 7
Write Enable to Output in High-Z	t _{HZWE}	0	6.5	0	7	0	8	0	8	0	10	0	25	0	30	ns	4, 6, 7

AC TEST CONDITIONS

Input pulse levels	V _{ss} to 3.0V
Input rise and fall times	3ns
Input timing reference levels	1.5V
Output reference levels	1.5V
Output load	See Figures 1 and 2

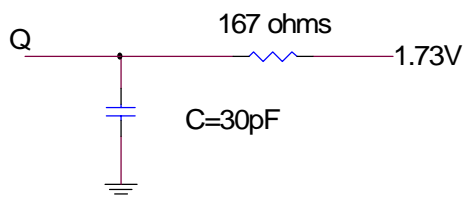

Fig. 1 Output Load Equivalent

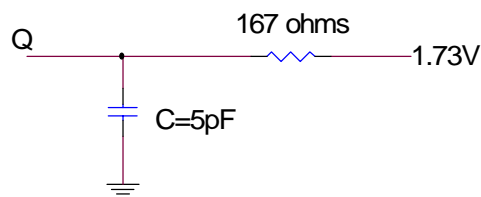

Fig. 2 Output Load Equivalent

NOTES

1. All voltages referenced to V_{ss} (GND).
2. -2V for pulse width < 20ns
3. I_{CC} is dependent on output loading and cycle rates.
4. This parameter is guaranteed but not tested.
5. Test conditions as specified with the output loading as shown in Fig. 1 unless otherwise noted.
6. 'LZCE, 'LZWE, 'LZOE, 'HZCE, 'HZOE and 'HZWE are specified with CL = 5pF as in Fig. 2. Transition is measured ±200mV from steady state voltage.
7. At any given temperature and voltage condition, 'HZCE is less than 'LZCE, and 'HZWE is less than 'LZWE.
8. WE\ is HIGH for READ cycle.
9. Device is continuously selected. Chip enables and output enables are held in their active state.
10. Address valid prior to, or coincident with, latest occurring chip enable.
11. 'RC = Read Cycle Time.
12. Chip enable and write enable can initiate and terminate a WRITE cycle.
13. Output enable (OE\) is inactive (HIGH).
14. Output enable (OE\) is active (LOW).
15. ASI does not warrant functionality nor reliability of any product in which the junction temperature exceeds 150°C. Care should be taken to limit power to acceptable levels.

DATA RETENTION ELECTRICAL CHARACTERISTICS (L Version Only)

DESCRIPTION	CONDITIONS	SYMBOL	MIN	MAX	UNITS	NOTES
V _{CC} for Retention Data	CE\ > (V _{CC} - 0.2V) VIN > (V _{CC} - 0.2V) or < 0.2V	V _{DR}	2		V	
Data Retention Current (L Version Only)	V _{CC} = 2V	I _{CCDR}		4.5	mA	
Chip Deselect to Data Retention Time		t _{CDR}	0		ns	4
Operation Recovery Time		t _R	10		ms	4, 11

LOW V_{CC} DATA RETENTION WAVEFORM

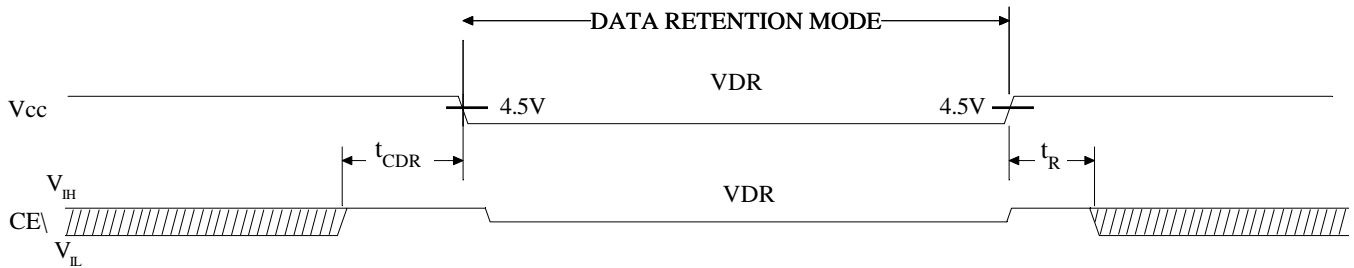

READ CYCLE NO. 1 ^{8,9}
(Write Enabled Controlled)

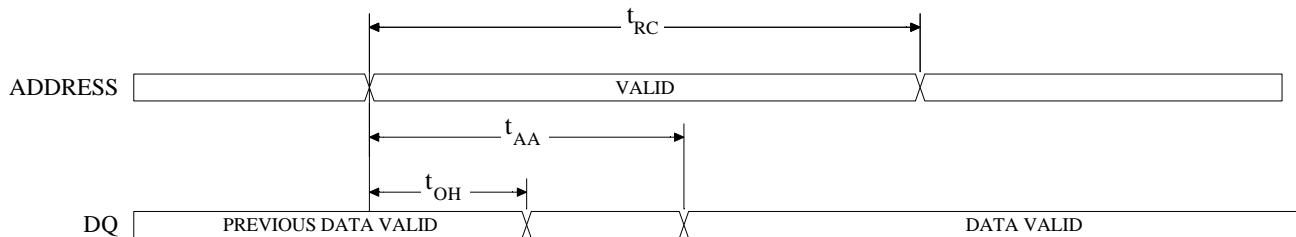

READ CYCLE NO. 2 ^{7,8,10}
(Write Enabled Controlled)

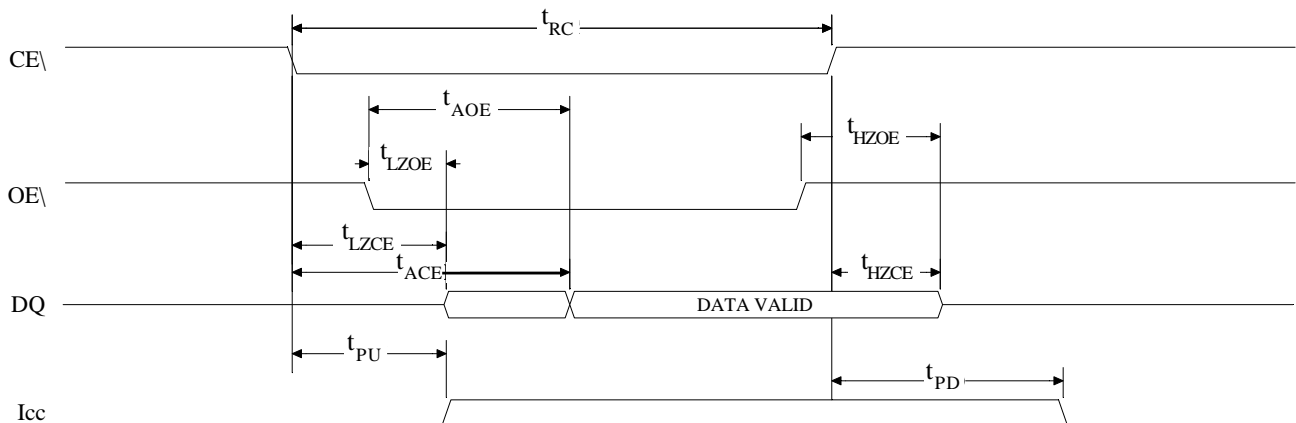

WRITE CYCLE NO. 1 ¹²
(Chip Enabled Controlled)

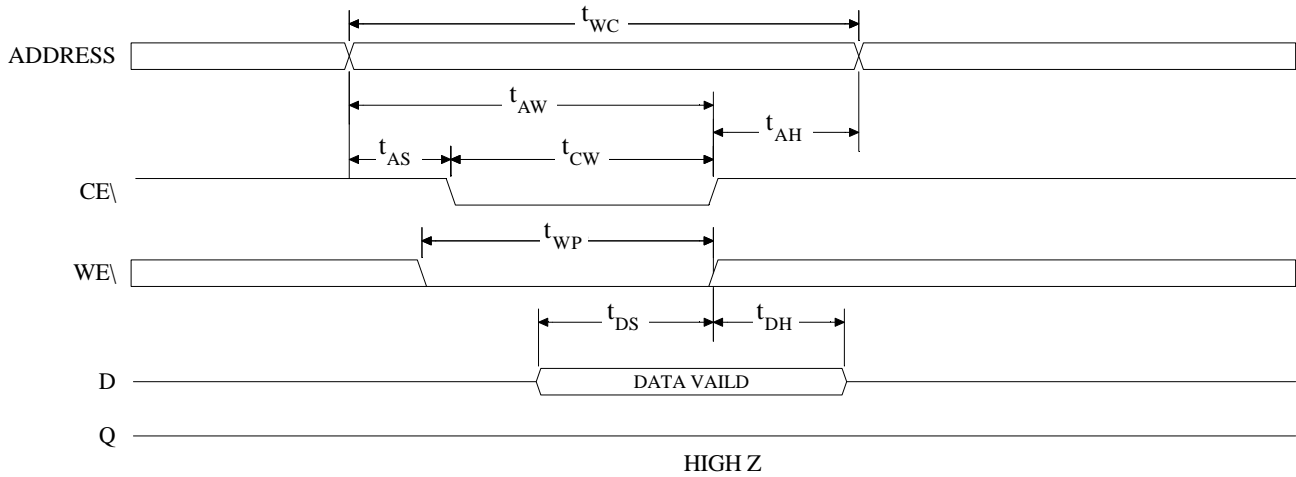

WRITE CYCLE NO. 2 ^{12, 13}
(Write Enabled Controlled)

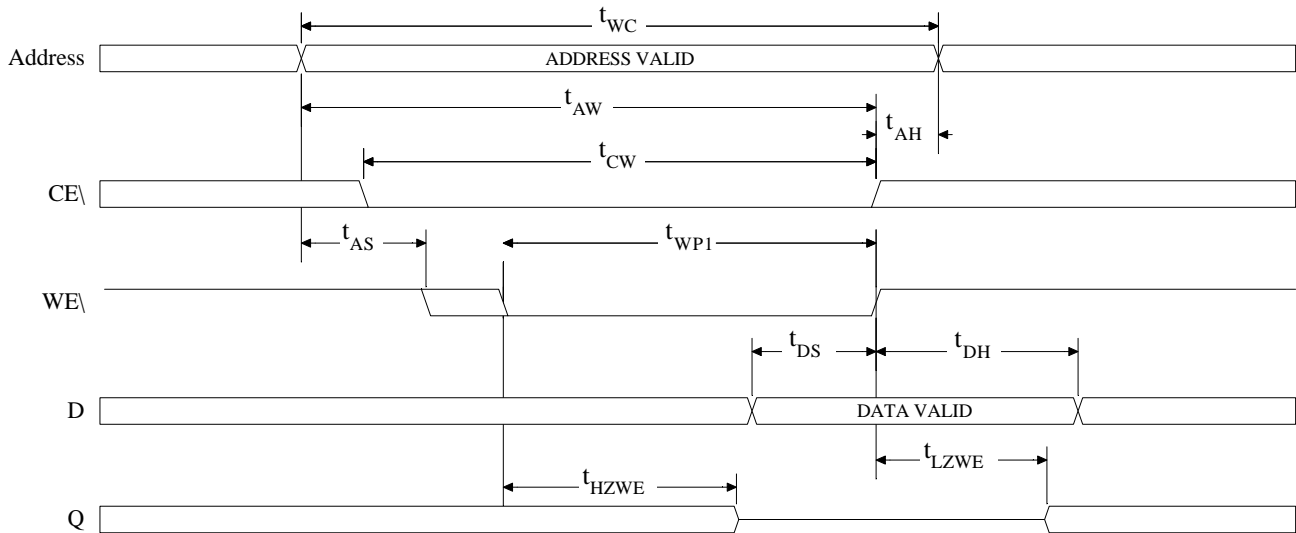

WRITE CYCLE NO. 37, 12, 14
(Write Enable Controlled)

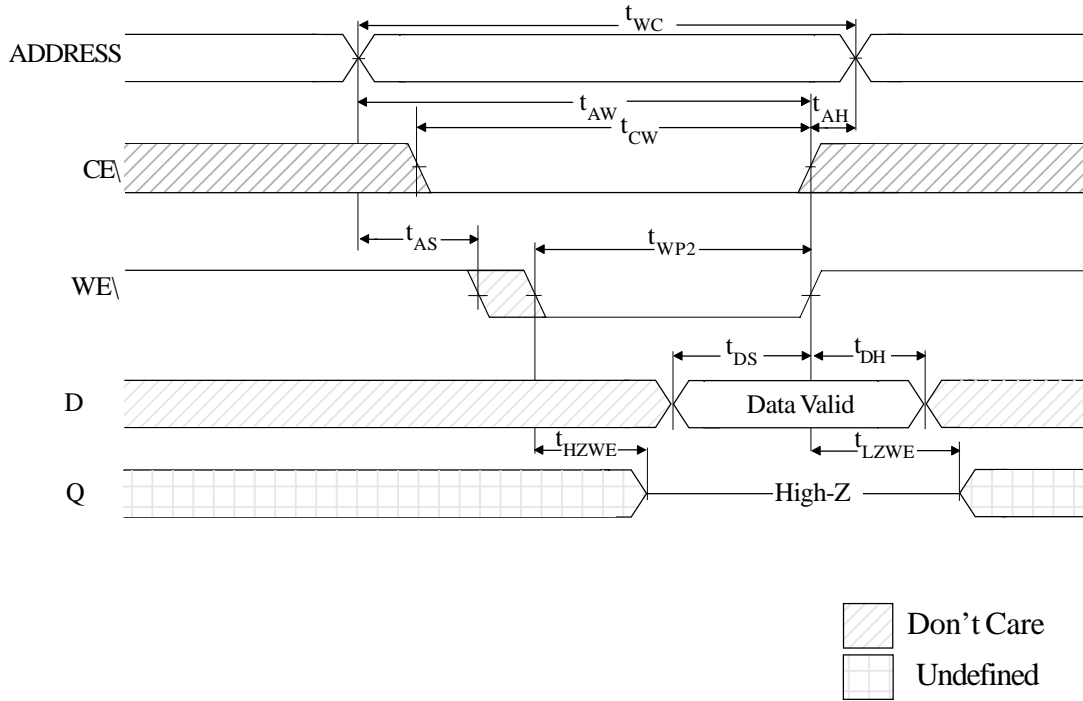

MECHANICAL DEFINITION*

**ASI Case #112 (Package Designator CW)
SMD 5962-95600, Case Outline X**

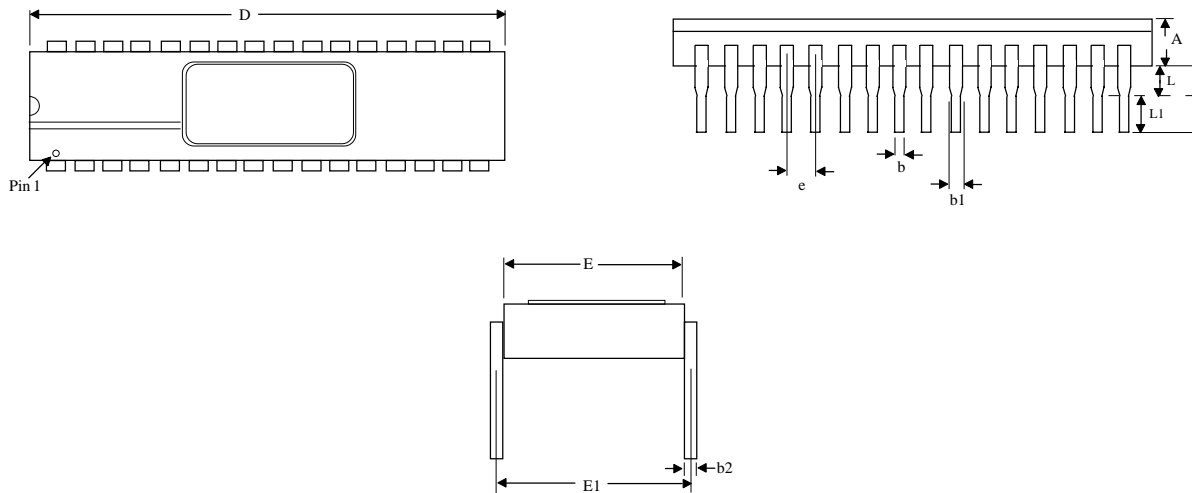

SYMBOL	SMD Specifications	
	MIN	MAX
A	---	0.225
b	0.014	0.026
b1	0.045	0.065
b2	0.008	0.018
D	---	1.680
E	0.510	0.620
e	0.100 BSC	
E1	0.600 BSC	
L1	0.125	0.200
L	0.015	0.070

NOTE: These dimensions are per the SMD. ASI's package dimensional limits may differ, but they will be within the SMD limits.

*All measurements are in inches.

MECHANICAL DEFINITION*

**ASI Case #304 (Package Designator F)
SMD 5962-95600, Case Outline 9**

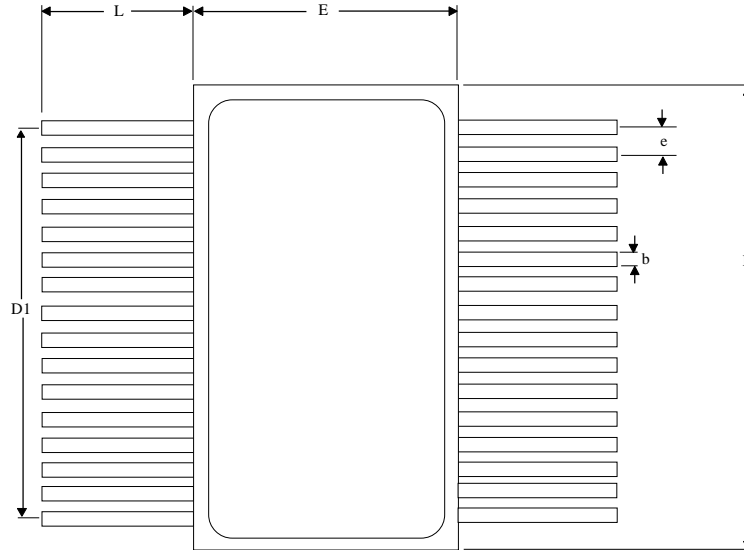

Top View

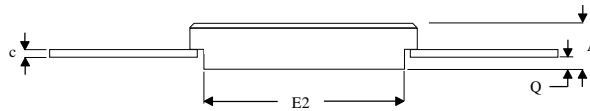

SYMBOL	SMD SPECIFICATIONS	
	MIN	MAX
A	0.096	0.114
b	0.008	0.019
c	0.003	0.008
D	0.816	0.838
D1	0.742	0.758
E	0.419	0.460
E2	0.345	0.427
e	0.050 BSC	
L	0.290	0.310
Q	0.024	0.038

NOTE: These dimensions are per the SMD. ASI's package dimensional limits may differ, but they will be within the SMD limits.

*All measurements are in inches.

MECHANICAL DEFINITION*

**ASI Case #209 (Package Designator EC)
SMD 5962-95600, Case Outline Z**

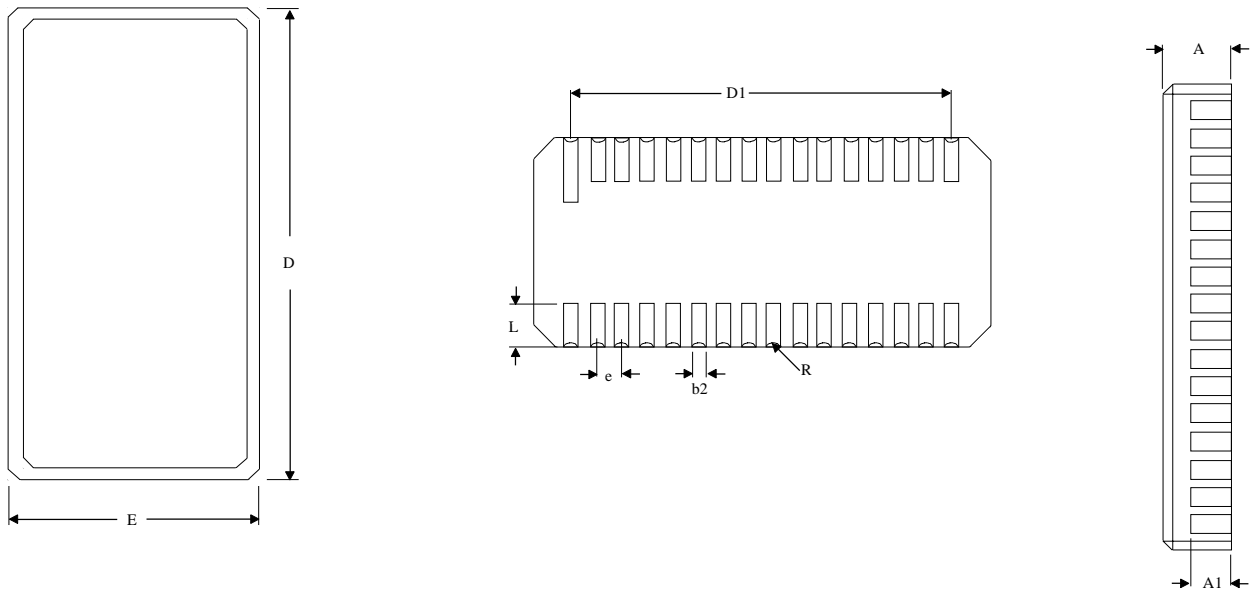

SYMBOL	SMD SPECIFICATIONS	
	MIN	MAX
A	0.080	0.100
A1	0.006	0.054
b2	0.022	0.028
D	0.815	0.835
D1	0.740	0.760
E	0.440	0.460
e	0.050 BSC	
L	0.100 REF	
R	0.009 REF	

NOTE: These dimensions are per the SMD. ASI's package dimensional limits may differ, but they will be within the SMD limits.

*All measurements are in inches.

MECHANICAL DEFINITION*

ASI Case #502 (Package Designator ECJ)

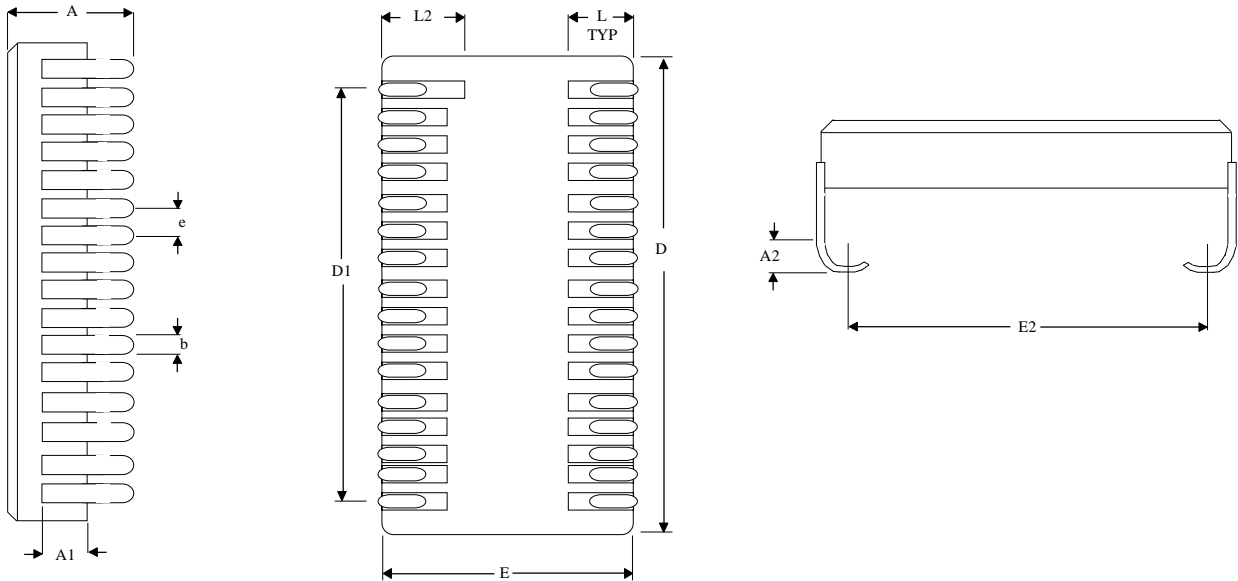

SYMBOL	ASI SPECIFICATIONS	
	MIN	MAX
A	0.115	0.160
A1	0.054	0.075
A2	0.025	0.063
b	0.012	0.028
D	0.815	0.835
D1	0.740	0.760
E	0.418	0.460
E2	0.371	0.440
e	0.050 BSC	
L	0.050	0.070
L2	0.115	0.135

NOTE: This package meets SMD 5962-95600, Case Outline U dimensions in every aspect, except dimension E2.

*All measurements are in inches.

MECHANICAL DEFINITION*

ASI Case #208 (Package Designator ECA)

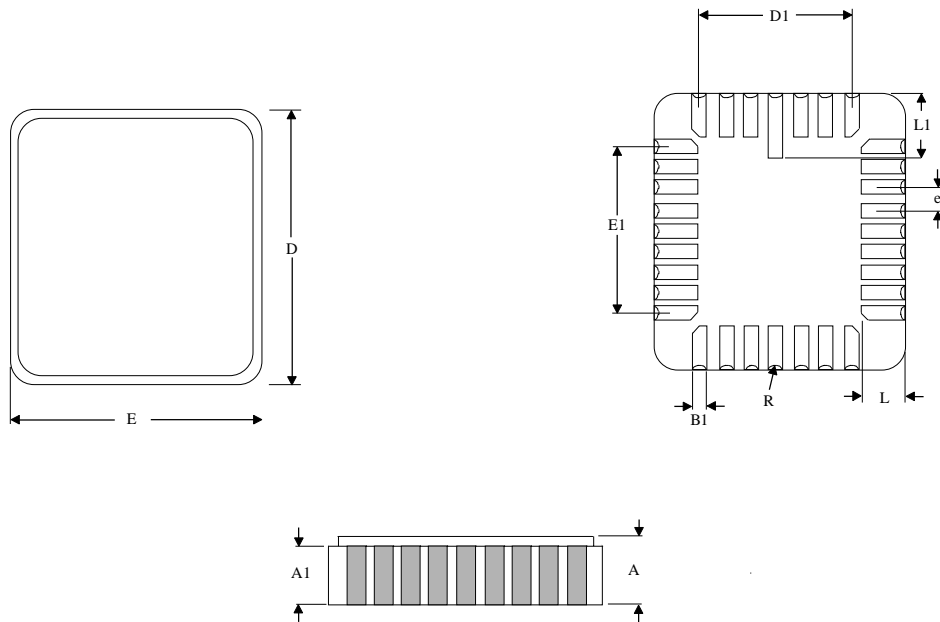

SYMBOL	SMD SPECIFICATIONS	
	MIN	MAX
A	0.060	0.080
A1	0.040	0.050
B1	0.022	0.028
D	0.540	0.560
D1	0.390	0.410
E	0.442	0.458
E1	0.290	0.310
e	0.045	0.055
L	0.045	0.055
L1	0.075	0.095
R	0.004	0.014

*All measurements are in inches.



ORDERING INFORMATION

EXAMPLE: AS5C4008CW-25L/883C

Device Number	Package Type	Speed ns	Options**	Process
AS5C4008	CW	-12	L	/*
AS5C4008	CW	-15	L	/*
AS5C4008	CW	-17	L	/*
AS5C4008	CW	-20	L	/*
AS5C4008	CW	-25	L	/*
AS5C4008	CW	-35	L	/*
AS5C4008	CW	-45	L	/*

EXAMPLE: AS5C4008ECA-45/883C

Device Number	Package Type	Speed ns	Options**	Process
AS5C4008	ECA	-12	L	/*
AS5C4008	ECA	-15	L	/*
AS5C4008	ECA	-17	L	/*
AS5C4008	ECA	-20	L	/*
AS5C4008	ECA	-25	L	/*
AS5C4008	ECA	-35	L	/*
AS5C4008	ECA	-45	L	/*

EXAMPLE: AS5C4008EC-20/883C

Device Number	Package Type	Speed ns	Options**	Process
AS5C4008	EC	-12	L	/*
AS5C4008	ECJ	-12	L	/*
AS5C4008	EC	-15	L	/*
AS5C4008	ECJ	-15	L	/*
AS5C4008	EC	-17	L	/*
AS5C4008	ECJ	-17	L	/*
AS5C4008	EC	-20	L	/*
AS5C4008	ECJ	-20	L	/*
AS5C4008	EC	-25	L	/*
AS5C4008	ECJ	-25	L	/*
AS5C4008	EC	-35	L	/*
AS5C4008	ECJ	-35	L	/*
AS5C4008	EC	-45	L	/*
AS5C4008	ECJ	-45	L	/*

EXAMPLE: AS5C4008F-45L/883C

Device Number	Package Type	Speed ns	Options**	Process
AS5C4008	F	-12	L	/*
AS5C4008	F	-15	L	/*
AS5C4008	F	-17	L	/*
AS5C4008	F	-20	L	/*
AS5C4008	F	-25	L	/*
AS5C4008	F	-35	L	/*
AS5C4008	F	-45	L	/*

***AVAILABLE PROCESSES**

IT = Industrial Temperature Range
 XT = Extended Temperature Range
 883C = Full Military Processing

-40°C to +85°C
 -55°C to +125°C
 -55°C to +125°C

****DEFINITION OF OPTIONS**

2V Data Retention/Low Power

L



ASI TO DSCC PART NUMBER CROSS REFERENCE FOR 5962-95600*

ASI Package Designator CW

ASI Part #	SMD Part #
AS5C4008CW-12L	5962-9560015QXA
AS5C4008CW-12L	5962-9560016QXA
AS5C4008CW-15	5962-9560014QXA
AS5C4008CW-15L	5962-9560013QXA
AS5C4008CW-20L	5962-9560012QXA
AS5C4008CW-25L	5962-9560011QXA
AS5C4008CW-35L	5962-9560010QXA
AS5C4008CW-45L	5962-9560009QXA
AS5C4008CW-20	5962-9560004MXA
AS5C4008CW-20L	5962-9560008MXA
AS5C4008CW-25	5962-9560003MXA
AS5C4008CW-25L	5962-9560007MXA
AS5C4008CW-35	5962-9560002MXA
AS5C4008CW-35L	5962-9560006MXA
AS5C4008CW-45	5962-9560001MXA
AS5C4008CW-45L	5962-9560005MXA

ASI Package Designator F

ASI Part #	SMD Part #
AS5C4008F-12L	5962-9560015Q9A
AS5C4008F-12L	5962-9560016Q9A
AS5C4008F-15	5962-9560014Q9A
AS5C4008F-15L	5962-9560013Q9A
AS5C4008F-20L	5962-9560012Q9A
AS5C4008F-25L	5962-9560011Q9A
AS5C4008F-35L	5962-9560010Q9A
AS5C4008F-45L	5962-9560009Q9A
AS5C4008F-20	5962-9560004M9A
AS5C4008F-20L	5962-9560008M9A
AS5C4008F-25	5962-9560003M9A
AS5C4008F-25L	5962-9560007M9A
AS5C4008F-35	5962-9560002M9A
AS5C4008F-35L	5962-9560006M9A
AS5C4008F-45	5962-9560001M9A
AS5C4008F-45L	5962-9560005M9A

ASI Package Designator EC

ASI Part #	SMD Part #
AS5C4008EC-12L	5962-9560015QZA
AS5C4008EC-12L	5962-9560016QZA
AS5C4008EC-15	5962-9560014QZA
AS5C4008EC-15L	5962-9560013QZA
AS5C4008EC-20L	5962-9560012QZA
AS5C4008EC-25L	5962-9560011QZA
AS5C4008EC-35L	5962-9560010QZA
AS5C4008EC-45L	5962-9560009QZA
AS5C4008EC-20	5962-9560004MZA
AS5C4008EC-20L	5962-9560008MZA
AS5C4008EC-25	5962-9560003MZA
AS5C4008EC-25L	5962-9560007MZA
AS5C4008EC-35	5962-9560002MZA
AS5C4008EC-35L	5962-9560006MZA
AS5C4008EC-45	5962-9560001MZA
AS5C4008EC-45L	5962-9560005MZA

ASI Package Designator ECJ

ASI Part #	SMD Part #
AS5C4008ECJ-12L	5962-9560015QUA
AS5C4008ECJ-12L	5962-9560016QUA
AS5C4008ECJ-15	5962-9560014QUA
AS5C4008ECJ-15L	5962-9560013QUA
AS5C4008ECJ-20L	5962-9560012QUA
AS5C4008ECJ-25L	5962-9560011QUA
AS5C4008ECJ-35L	5962-9560010QUA
AS5C4008ECJ-45L	5962-9560009QUA
AS5C4008ECJ-20	5962-9560004MUA
AS5C4008ECJ-20L	5962-9560008MUA
AS5C4008ECJ-25	5962-9560003MUA
AS5C4008ECJ-25L	5962-9560007MUA
AS5C4008ECJ-35	5962-9560002MUA
AS5C4008ECJ-35L	5962-9560006MUA
AS5C4008ECJ-45	5962-9560001MUA
AS5C4008ECJ-45L	5962-9560005MUA

* ASI part number is for reference only. Orders received referencing the SMD part number will be processed per the SMD.



ASI TO DSCC PART NUMBER CROSS REFERENCE FOR 5962-95613*

ASI Package Designator CW

ASI Part #	SMD Part #
AS5C4008CW-12/H	5962-9561329HYA
AS5C4008CW-12/LH	5962-9561328HYA
AS5C4008CW-15/H	5962-9561314HYA
AS5C4008CW-17/H	5962-9561310HYA
AS5C4008CW-17/LH	5962-9561324HYA
AS5C4008CW-20/H	5962-9561309HYA
AS5C4008CW-20/LH	5962-9561323HYA
AS5C4008CW-25/H	5962-9561308HYA
AS5C4008CW-25/H	5962-9561313HYA
AS5C4008CW-25/LH	5962-9561322HYA
AS5C4008CW-25/LH	5962-9561327HYA
AS5C4008CW-35/H	5962-9561307HYA
AS5C4008CW-35/H	5962-9561312HYA
AS5C4008CW-35/LH	5962-9561321HYA
AS5C4008CW-35/LH	5962-9561326HYA
AS5C4008CW-45/H	5962-9561306HYA
AS5C4008CW-45/H	5962-9561311HYA
AS5C4008CW-45/LH	5962-9561320HYA
AS5C4008CW-45/LH	5962-9561325HYA
AS5C4008CW-55/H	5962-9561305HYA
AS5C4008CW-55/LH	5962-9561319HYA

AS5C4008CW-12/H	5962-9561329HYC
AS5C4008CW-12/LH	5962-9561328HYC
AS5C4008CW-15/H	5962-9561314HYC
AS5C4008CW-17/H	5962-9561310HYC
AS5C4008CW-17/LH	5962-9561324HYC
AS5C4008CW-20/H	5962-9561309HYC
AS5C4008CW-20/LH	5962-9561323HYC
AS5C4008CW-25/H	5962-9561308HYC
AS5C4008CW-25/H	5962-9561313HYC
AS5C4008CW-25/LH	5962-9561322HYC
AS5C4008CW-25/LH	5962-9561327HYC
AS5C4008CW-35/H	5962-9561307HYC
AS5C4008CW-35/H	5962-9561312HYC
AS5C4008CW-35/LH	5962-9561321HYC
AS5C4008CW-35/LH	5962-9561326HYC
AS5C4008CW-45/H	5962-9561306HYC
AS5C4008CW-45/H	5962-9561311HYC
AS5C4008CW-45/LH	5962-9561320HYC
AS5C4008CW-45/LH	5962-9561325HYC
AS5C4008CW-55/H	5962-9561305HYC
AS5C4008CW-55/LH	5962-9561319HYC

ASI Package Designator F

ASI Part #	SMD Part #
AS5C4008F-12/H	5962-9561329H9A
AS5C4008F-12/LH	5962-9561328H9A
AS5C4008F-15/H	5962-9561314H9A
AS5C4008F-17/H	5962-9561310H9A
AS5C4008F-17/LH	5962-9561324H9A
AS5C4008F-20/H	5962-9561309H9A
AS5C4008F-20/LH	5962-9561323H9A
AS5C4008F-25/H	5962-9561308H9A
AS5C4008F-25/H	5962-9561313H9A
AS5C4008F-25/LH	5962-9561322H9A
AS5C4008F-25/LH	5962-9561327H9A
AS5C4008F-35/H	5962-9561307H9A
AS5C4008F-35/H	5962-9561312H9A
AS5C4008F-35/LH	5962-9561321H9A
AS5C4008F-35/LH	5962-9561326H9A
AS5C4008F-45/H	5962-9561306H9A
AS5C4008F-45/H	5962-9561311H9A
AS5C4008F-45/LH	5962-9561320H9A
AS5C4008F-45/LH	5962-9561325H9A
AS5C4008F-55/H	5962-9561305H9A
AS5C4008F-55/LH	5962-9561319H9A

AS5C4008F-12/H	5962-9561329H9C
AS5C4008F-12/LH	5962-9561328H9C
AS5C4008F-15/H	5962-9561314H9C
AS5C4008F-17/H	5962-9561310H9C
AS5C4008F-17/LH	5962-9561324H9C
AS5C4008F-20/H	5962-9561309H9C
AS5C4008F-20/LH	5962-9561323H9C
AS5C4008F-25/H	5962-9561308H9C
AS5C4008F-25/H	5962-9561313H9C
AS5C4008F-25/LH	5962-9561322H9C
AS5C4008F-25/LH	5962-9561327H9C
AS5C4008F-35/H	5962-9561307H9C
AS5C4008F-35/H	5962-9561312H9C
AS5C4008F-35/LH	5962-9561321H9C
AS5C4008F-35/LH	5962-9561326H9C
AS5C4008F-45/H	5962-9561306H9C
AS5C4008F-45/H	5962-9561311H9C
AS5C4008F-45/LH	5962-9561320H9C
AS5C4008F-45/LH	5962-9561325H9C
AS5C4008F-55/H	5962-9561305H9C
AS5C4008F-55/LH	5962-9561319H9C

* ASI part number is for reference only. Orders received referencing the SMD part number will be processed per the SMD.



ASI TO DSCC PART NUMBER CROSS REFERENCE FOR 5962-95613*

ASI Package Designator EC

ASI Part #	SMD Part #
AS5C4008EC-12/H	5962-9561329HMA
AS5C4008EC-12/LH	5962-9561328HMA
AS5C4008EC-15/H	5962-9561314HMA
AS5C4008EC-17/H	5962-9561310HMA
AS5C4008EC-17/LH	5962-9561324HMA
AS5C4008EC-20/H	5962-9561309HMA
AS5C4008EC-20/LH	5962-9561323HMA
AS5C4008EC-25/H	5962-9561308HMA
AS5C4008EC-25/H	5962-9561313HMA
AS5C4008EC-25/LH	5962-9561327HMA
AS5C4008EC-25/LH	5962-9561322HMA
AS5C4008EC-35/H	5962-9561307HMA
AS5C4008EC-35/H	5962-9561312HMA
AS5C4008EC-35/LH	5962-9561326HMA
AS5C4008EC-35/LH	5962-9561321HMA
AS5C4008EC-45/H	5962-9561306HMA
AS5C4008EC-45/H	5962-9561311HMA
AS5C4008EC-45/LH	5962-9561320HMA
AS5C4008EC-45/LH	5962-9561325HMA
AS5C4008EC-55/H	5962-9561305HMA
AS5C4008EC-55/LH	5962-9561319HMA

ASI Package Designator ECJ

ASI Part #	SMD Part #
AS5C4008ECJ-12/H	5962-9561329HTA
AS5C4008ECJ-12/LH	5962-9561328HTA
AS5C4008ECJ-15/H	5962-9561314HTA
AS5C4008ECJ-17/LH	5962-9561324HTA
AS5C4008ECJ-20/LH	5962-9561323HTA
AS5C4008ECJ-25/H	5962-9561313HTA
AS5C4008ECJ-25/LH	5962-9561322HTA
AS5C4008ECJ-25/LH	5962-9561327HTA
AS5C4008ECJ-35/H	5962-9561312HTA
AS5C4008ECJ-45/H	5962-9561311HTA
AS5C4008ECJ-17/H	5962-9561310HTA
AS5C4008ECJ-20/H	5962-9561309HTA
AS5C4008ECJ-25/H	5962-9561308HTA
AS5C4008ECJ-35/H	5962-9561307HTA
AS5C4008ECJ-35/LH	5962-9561321HTA
AS5C4008ECJ-35/LH	5962-9561326HTA
AS5C4008ECJ-45/H	5962-9561306HTA
AS5C4008ECJ-45/LH	5962-9561325HTA
AS5C4008ECJ-45/LH	5962-9561320HTA
AS5C4008ECJ-55/H	5962-9561305HTA
AS5C4008ECJ-55/LH	5962-9561319HTA

AS5C4008EC-12/H	5962-9561329HMC
AS5C4008EC-12/LH	5962-9561328HMC
AS5C4008EC-15/H	5962-9561314HMC
AS5C4008EC-17/H	5962-9561310HMC
AS5C4008EC-17/LH	5962-9561324HMC
AS5C4008EC-20/H	5962-9561309HMC
AS5C4008EC-20/LH	5962-9561323HMC
AS5C4008EC-25/H	5962-9561308HMC
AS5C4008EC-25/H	5962-9561313HMC
AS5C4008EC-25/LH	5962-9561327HMC
AS5C4008EC-25/LH	5962-9561322HMC
AS5C4008EC-35/H	5962-9561307HMC
AS5C4008EC-35/H	5962-9561312HMC
AS5C4008EC-35/LH	5962-9561326HMC
AS5C4008EC-35/LH	5962-9561321HMC
AS5C4008EC-45/H	5962-9561306HMC
AS5C4008EC-45/H	5962-9561311HMC
AS5C4008EC-45/LH	5962-9561320HMC
AS5C4008EC-45/LH	5962-9561325HMC
AS5C4008EC-55/H	5962-9561305HMC
AS5C4008EC-55/LH	5962-9561319HMC

AS5C4008ECJ-12/H	5962-9561329HTC
AS5C4008ECJ-12/LH	5962-9561328HTC
AS5C4008ECJ-15/H	5962-9561314HTC
AS5C4008ECJ-20/LH	5962-9561323HTC
AS5C4008ECJ-17/LH	5962-9561324HTC
AS5C4008ECJ-25/H	5962-9561313HTC
AS5C4008ECJ-25/LH	5962-9561322HTC
AS5C4008ECJ-25/LH	5962-9561327HTC
AS5C4008ECJ-35/H	5962-9561312HTC
AS5C4008ECJ-45/H	5962-9561311HTC
AS5C4008ECJ-17/H	5962-9561310HTC
AS5C4008ECJ-20/H	5962-9561309HTC
AS5C4008ECJ-25/H	5962-9561308HTC
AS5C4008ECJ-35/H	5962-9561307HTC
AS5C4008ECJ-35/LH	5962-9561321HTC
AS5C4008ECJ-35/LH	5962-9561326HTC
AS5C4008ECJ-45/H	5962-9561306HTC
AS5C4008ECJ-45/LH	5962-9561325HTC
AS5C4008ECJ-45/LH	5962-9561320HTC
AS5C4008ECJ-55/H	5962-9561305HTC
AS5C4008ECJ-55/LH	5962-9561319HTC

* ASI part number is for reference only. Orders received referencing the SMD part number will be processed per the SMD.