

EXTENDED REACH MULTI-RATE OC-48/STM-16 LR-2/L-16.2 SFP CWDM TRANSCEIVERS WITH DIGITAL DIAGNOSTICS

TRPE48KE2 CWDM

Product Description

The TRPE48KE2 CWDM SFP series of multi-rate fiber optic transceivers with digital diagnostics monitoring functionality provide a quick and reliable interface for extended reach LR-2 applications. Diagnostics monitoring functionality (alarm and warning features) is integrated into the design via an I²C serial interface per the Multi-Source Agreement (MSA) SFF-8472, Rev. 9.4.

Products under this series are compatible with SONET/SDH standards for OC-48/STM-16 (2.488Gb/s) LR-2/ L-16.2 extended reach applications, OC-3/STM-1 (156Mb/s) and OC-12/STM-4 (622Mb/s) SR/I-1 and I-4 short reach applications; Gigabit Ethernet LX (1.25Gb/s) applications per IEEE 802.3; and Fibre Channel 200-SM-LC-L (2.125Gb/s) and 100-SM-LC-L (1.062Gb/s) applications per FC-PI standards. The transceivers support data rates ranging from 2.67Gb/s down to 125Mb/s and are available in eight (8) wavelengths: 1471nm, 1491nm, 1511nm, 1531nm, 1551nm, 1571nm, 1591nm and 1611nm. The higher optical link power budget of 32dB is to accommodate the wavelength multiplexing and de-multiplexing insertion losses. All transceivers are Class I Laser products per U.S. FDA/CDRH and international IEC-60825 standards.

The TRPE48KE2 CWDM transceivers connect to standard 20-pad SFP connectors for hot plug capability. This allows the system designer to make configuration changes or maintenance by simply plugging in different types of transceivers without removing the power supply from the host system.

The transceivers have colored bail-type latches, which offer an easy and convenient way to release the modules. The latch is compliant with the SFP MSA.

The transmitter and receiver DATA interfaces are AC-coupled internally. LV-TTL Transmitter Disable control input and Loss of Signal (LOS) output interfaces are also provided.



Features

- Distance up to 100km with Single Mode Fiber
- Eight (8) Wavelength CWDM Transceivers
- Compatible with SFP MSA
- Compatible with SONET/SDH OC-48/STM-16 (2.488Gb/s) LR-2/L-16.2 Applications
- Compatible with Gigabit Ethernet LX
- Compatible with Fibre Channel 200-SM-LC-L and 100-SM-LC-L
- Digital Diagnostics through Serial Interface
- Internal Calibration for Digital Diagnostics
- APD Receiver
- Optical Link Power Budget of 32dB Minimum
- Eye Safe (Class I Laser Safety)
- Hot-pluggable
- TX Fault & Loss of Signal Outputs
- TX Disable Input

Absolute Maximum Ratings

Parameter	Symbol	Minimum	Maximum	Units
Storage Temperature	T_{ST}	- 40	+ 85	°C
Operating Case Temperature ¹	Commercial Temp.	- 5	+ 70	°C
	Extended Temp.	- 5	+ 85	
Supply Voltage	V_{CC}	0	+ 4.5	V
Maximum Input Optical Power (30 seconds max.)	$P_{in,max}$	-	+ 3.0	dBm
Input Voltage	V_{IN}	0	V_{CC}	V

¹Measured on top side of SFP module at the front center vent hole of the cage.

Transmitter Performance Characteristics (Over Operating Case Temperature. $V_{CC} = 3.13$ to $3.47V$)

All parameters guaranteed only at typical data rate

Parameter		Symbol	Minimum	Typical	Maximum	Units
Operating Data Rate		B	0.125	-	2.67	Gb/s
Average Optical Output Power (coupled into single mode fiber), 50% duty cycle		P_O	+ 1.0	-	+ 5.0	dBm
Extinction Ratio		P_{hi}/P_{lo}	8.2	-	-	dB
Center Wavelength	1471	λ_C	1464.5	1471	1477.5	nm
	1491		1484.5	1491	1497.5	
	1511		1504.5	1511	1517.5	
	1531		1524.5	1531	1537.5	
	1551		1544.5	1551	1557.5	
	1571		1564.5	1571	1577.5	
	1591		1584.5	1591	1597.5	
	1611		1604.5	1611	1617.5	
Spectral Width (-20dB)		$\Delta\lambda_{20}$	-	-	1.0	nm
Side Mode Suppression Ratio		$SMSR$	30.0	-	-	dB
Optical Rise/Fall Time (20% to 80%)		t_r, t_f	-	-	0.16	ns
Relative Intensity Noise		RIN	--	-	- 117	dB/Hz
Jitter Generation	OC-48	JG	-	-	0.07	Ulp-p
Dispersion Penalty ¹		-	--	-	2.5	dB
Optical Output Eye		Compliant with Telcordia GR-253-CORE and ITU-T Recommendation G.957				
¹ Specified at 2000ps/nm dispersion over G.652/G.654 fiber with center wavelength range of 1464.5-1617.5nm.						

Receiver Performance Characteristics (Over Operating Case Temperature. $V_{CC} = 3.13$ to $3.47V$)

All parameters guaranteed only at typical data rate

Parameter		Symbol	Minimum	Typical	Maximum	Units
Operating Data Rate ¹		B	0.125	-	2.67	Gb/s
Receiver Sensitivity (10^{-10} BER) ¹	OC-3/12/48, 2.67Gb/s	P_{min}	- 31.0	-	-	dBm
Receiver Sensitivity (10^{-12} BER) ²	2.125Gb/s, 1.25Gb/s, 1.062Gb/s, 0.125Gb/s	P_{min}	- 31.0	-	-	dBm
Maximum Input Optical Power (10^{-12} BER)		P_{max}	- 8.0	-	-	dBm
LOS Thresholds	Increasing Light Input	P_{los+}	-	-	- 31.0	dBm
	Decreasing Light Input	P_{los-}	- 45.0	-	-	
LOS Timing Delay	Increasing Light Input	t_{loss_off}	-	-	100	μs
	Decreasing Light Input	t_{loss_on}	2.3	-	100	
LOS Hysteresis		-	0.5	1.5	6.0	dB
Wavelength of Operation		λ	1260	-	1620	nm
Receiver Reflectance		-	-	-	- 27.0	dB
¹ Measured with 2^{23} -1 PRBS.						
² Measured with 2^7 -1 PRBS.						

Transmitter Performance Characteristics (Over Operating Case Temperature. $V_{CC} = 3.13$ to $3.47V$)

Parameter	Symbol	Minimum	Typical	Maximum	Units
Input Voltage Swing (TD+ & TD-) ¹	V_{PP-DIF}	0.35	-	1.75	V
Input HIGH Voltage (TX Disable) ²	V_{IH}	2.0	-	V_{CC}	V
Input LOW Voltage (TX Disable) ²	V_{IL}	0	-	0.8	V
Output HIGH Voltage (TX Fault) ³	V_{OH}	2.0	-	$V_{CC} + 0.3$	V
Output LOW Voltage (TX Fault) ³	V_{OL}	0	-	0.8	V

¹Differential peak-to-peak voltage.
²There is an internal 4.7 to 10kΩ pull-up resistor to VccT.
³Open collector compatible, 4.7 to 10kΩ pull-up resistor to Vcc (Host Supply Voltage).

Receiver Electrical Interface (Over Operating Case Temperature. $V_{CC} = 3.13$ to $3.47V$)

Parameter	Symbol	Minimum	Typical	Maximum	Units
Output Voltage Swing (RD+ & RD-) ¹	V_{PP-DIF}	0.40	-	1.75	V
Output HIGH Voltage (LOS) ²	V_{OH}	$V_{CC} - 1.3$	-	$V_{CC} + 0.3$	V
Output LOW Voltage (LOS) ²	V_{OL}	0	-	0.5	V

¹Differential peak-to-peak voltage across external 100Ω load.
²Open collector compatible, 4.7 to 10kΩ pull-up resistor to Vcc (Host Supply Voltage).

Electrical Power Supply Characteristics (Over Operating Case Temperature. $V_{CC} = 3.13$ to $3.47V$)

Parameter	Symbol	Minimum	Typical	Maximum	Units
Supply Voltage	V_{CC}	3.13	3.3	3.47	V
Supply Current	I_{CC}	-	210	350	mA

Module Definition

MOD_DEF(0) pin 6	MOD_DEF(1) pin 5	MOD_DEF(2) pin 4	Interpretation by Host
TTL LOW	SCL	SDA	Serial module definition protocol

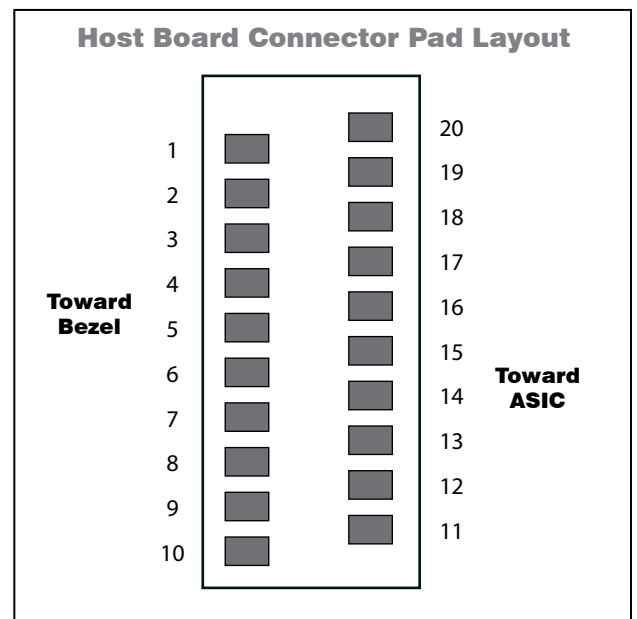
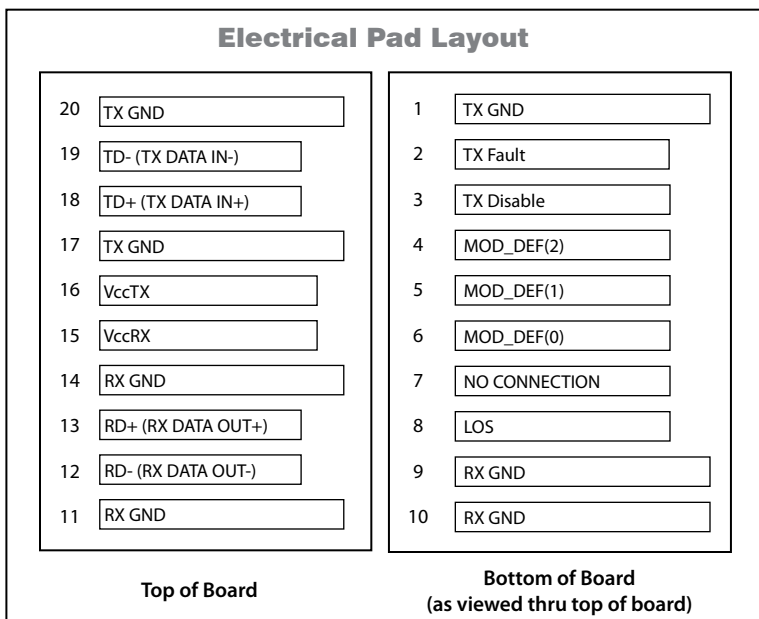

Example of SFP host board schematic

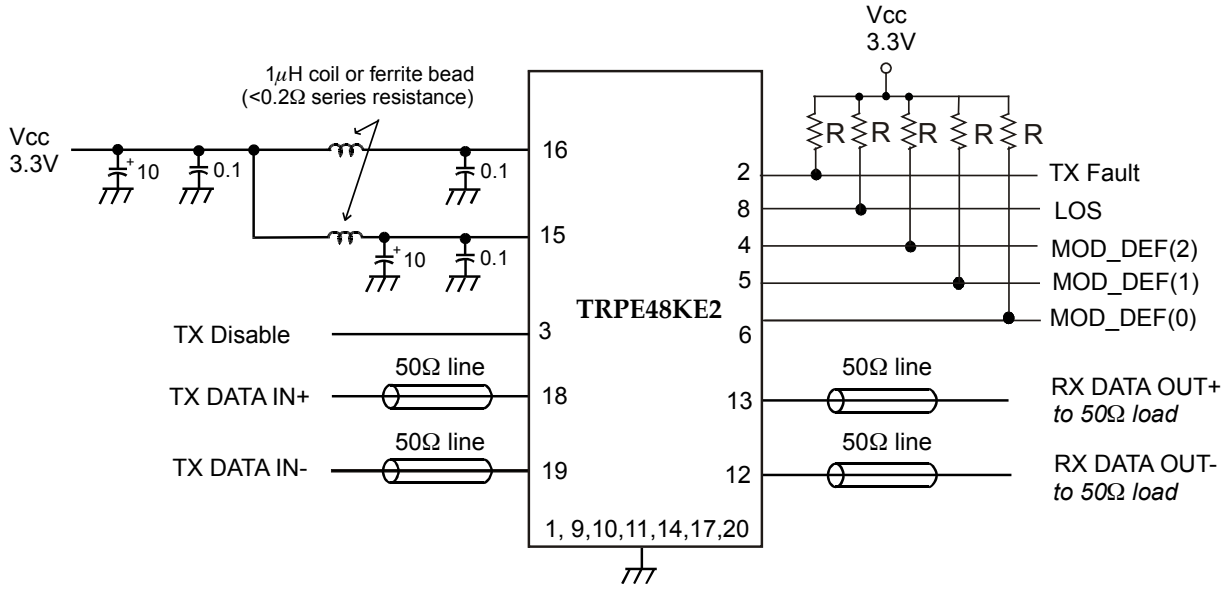

R: 4.7 to 10kΩ
CAP Values in µF

Application Notes

Electrical interface: All signal interfaces are compliant with the SFP MSA specification. The high speed DATA interface is differential AC-coupled internally with 1µF and can be directly connected to a 3.3V SERDES IC. All low speed control and sense output signals are open collector TTL compatible and should be pulled up with a 4.7 - 10kΩ resistor on the host board

Loss of Signal (LOS): The Loss of Signal circuit monitors the level of the incoming optical signal and generates a logic HIGH when an insufficient photocurrent is produced.

TX_Fault: The output indicates LOW when the transmitter is operating normally, and HIGH with a laser fault including laser end-of-life. TX Fault is an open collector/drain output that should be pulled up with a 4.7 - 10kΩ resistor on the host board. TX Fault in non-latching (automatically deasserts when fault goes away).

TX_Disable: When the TX Disable pin is at logic HIGH, the transmitter optical output is disabled (less than -45dBm).

Serial Identification and Monitoring: The module definition of SFP is indicated by the three module definition pins, MOD_DEF(0), MOD_DEF(1) and MOD_DEF(2).

Laser Safety

Laser Safety: All transceivers are Class I Laser products per FDA/CDRH and IEC-60825 standards. They must be operated under specified operating conditions.

Upon power up, MOD_DEF(1:2) appear as NC (no connection), and MOD_DEF(0) is TTL LOW. When the host system detects this condition, it activates the serial protocol (standard two-wire I²C serial interface) and generates the serial clock signal (SCL). The positive edge clocks data into the EEPROM segments of the SFP that are not write protected, and the negative edge clocks data from the SFP.

The serial data signal (SDA) is for serial data transfer. The host uses SDA in conjunction with SCL to mark the start and end of serial protocol activation. The supported monitoring functions are temperature, voltage, bias current, transmitter power, average receiver signal, all alarms and warnings, and software monitoring of TX Fault/LOS. The device is internally calibrated.

The data transfer protocol and the details of the mandatory and vendor specific data structures are defined in the SFP MSA, and SFF-8472, Rev. 9.4

Power Supply and Grounding: The power supply line should be well-filtered. All 0.1µF power supply bypass capacitors should be as close to the transceiver module as possible.

Oplink Communications, Inc.
DATE OF MANUFACTURE:



This product complies with
21 CFR 1040.10 and 1040.11
Meets Class I Laser Safety Requirements

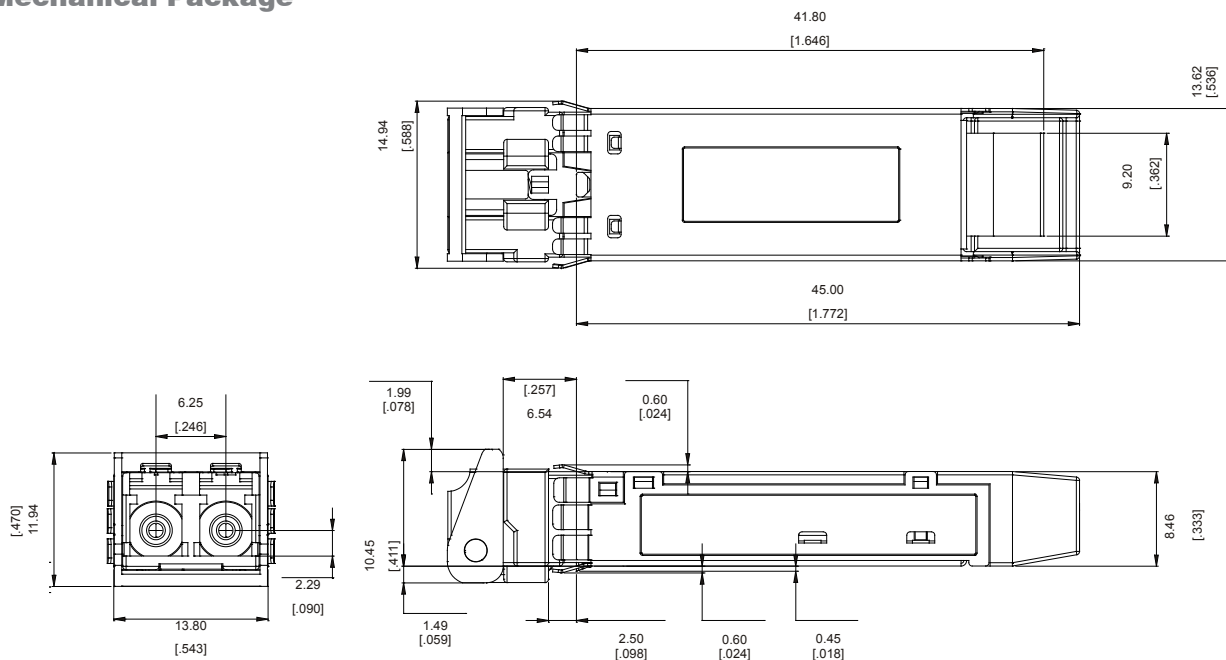

Mechanical Package

Dimensions in inches [mm]
 Default tolerances:
 .xxx = ± .005", .xx = ± .01"

Ordering Information

Part Number	Operating Temperature	Nominal Wavelength	Latch Color
32dB Link Budget (100km Distance)¹			
TRPE48KE2C00010	- 5°C to +70°C	1471nm	Gray
TRPE48KE2C00020	- 5°C to +70°C	1491nm	Violet
TRPE48KE2C00030	- 5°C to +70°C	1511nm	Blue
TRPE48KE2C00040	- 5°C to +70°C	1531nm	Green
TRPE48KE2C00050	- 5°C to +70°C	1551nm	Yellow
TRPE48KE2C00060	- 5°C to +70°C	1571nm	Orange
TRPE48KE2C00070	- 5°C to +70°C	1591nm	Red
TRPE48KE2C00080	- 5°C to +70°C	1611nm	Brown
TRPE48KE2E00010	- 5°C to +85°C	1471nm	Gray
TRPE48KE2E00020	- 5°C to +85°C	1491nm	Violet
TRPE48KE2E00030	- 5°C to +85°C	1511nm	Blue
TRPE48KE2E00040	- 5°C to +85°C	1531nm	Green
TRPE48KE2E00050	- 5°C to +85°C	1551nm	Yellow
TRPE48KE2E00060	- 5°C to +85°C	1571nm	Orange
TRPE48KE2E00070	- 5°C to +85°C	1591nm	Red
TRPE48KE2E00080	- 5°C to +85°C	1611nm	Brown

¹The indicated transmission distance is for guidelines only, not guaranteed. The exact distance is dependent on the fiber loss, connector and splice loss, and allocated system penalty. Longer distances can be supported if the optical link power budget is satisfied.

Oplink Communications, Inc. reserves the right to make changes in equipment design or specifications without notice. Information supplied by Oplink Communications, Inc. is believed to be accurate and reliable. However, no responsibility is assumed by Oplink Communications, Inc. for its use nor for any infringements of third parties, which may result from its use. No license is granted by implication or otherwise under any patent right of Oplink Communications, Inc.

© 2009, Oplink Communications, Inc.