

High Efficiency 2X charge Pump

FEATURES

- **Wide Input Range: 2.5V to 5.5V**
- **Available Output Voltages:**
2.5V/2.7V/3.0V/3.3V/4.0V/4.5V /5.0V/5.5V
- **Automatic Step-Up/Step-Down Operation**
- **Low Input Current Ripple**
- **Low Output Voltage Ripple**
- **Minimum Number of External Components-No Inductors**
- **Shutdown Mode**
- **Thermal Protection**
- **High Output Current :**
V_{IN}>3.0V Output Current 100mA
Max. 250mA for pulsed loads
- **Available Package : SOT23-6/ lead-free**

APPLICATIONS

- **Smart Card Readers**
- **Cellular Phones**
- **White LED Camera Flash**
- **White LED Backlighting**
- **Battery Backup Supplies**

GENERAL DESCRIPTION

The The T6319A is a switched capacitor voltage converter, that produces a regulated, low ripple output voltage from an unregulated input voltage. A wide-input supply voltage of 2.5V to 5.5V makes the T6319A ideal for a variety of battery sources, such as single cell Li-Ion, or two and three cell nickel or alkaline-based chemistries.

The input voltage may vary above and below the output voltage and the output will remain in regulation. It works equally well for step-up or step-down applications without the need for an inductor, providing low EMI DC/DC conversion. The high switching frequency allows the use of small surface-mount capacitors, saving board space and reducing cost. The T6319A is thermally protected.

PART NUMBER EXAMPLES

Part no.	Output Voltage	Package type
T6319A-25AXG	2.5V	SOT23-6 lead-free
T6319A-30AXG	3.0V	SOT23-6 lead-free
⋮	⋮	⋮
T6319A-50AXG	5.0V	SOT23-6 lead-free
T6319A-55AXG	5.5V	SOT23-6 lead-free

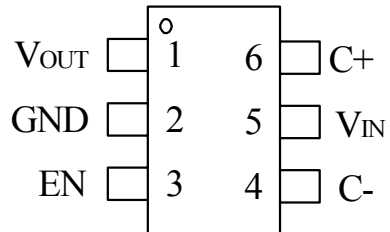
PIN ARRANGEMENT**SOT23-6 (Top view)****PIN DESCRIPTION**

SYMBOL	Pin No.	DESCRIPTION
V _{OUT}	1	Voltage output
GND	2	Ground pin
EN	3	Enable signal, high active
C-	4	Flying capacitor “-“ terminal
V _{IN}	5	Input supply pin.
C+	6	Flying capacitor “+” terminal

Absolute Maximum Ratings

Supply Voltage	-0.3V to 6V
EN Pin Input Voltage	-0.3V to 6V
Operating Junction Temperature	-55°C to +150°C
Operating temperature range	-55°C to +125°C
Storage temperature range	-65°C to +150°C
Lead temperature (soldering, 10sec)	300°C

Electrical Characteristics

($V_{IN}=+3.3V$, $T_A = 25^{\circ}C$, $C_{IN} = C_{OUT} = 10\mu F$, unless otherwise noted)

Symbol	Description	Conditions	Min.	Typ.	Max	Unit	
V_{IN}	Input Voltage		2.5		5.5	V	
V_{OUT}	Output Voltage Tolerance	$2.5V < V_{IN} < 5.5V$, $I_{OUT}=60mA$		4		%	
	Output Voltage	$2.5V < V_{IN} < V_{OUT}$, $I_{OUT}=100mA$	2.5V	2.40	2.5	2.60	V
			2.7V	2.59	2.7	2.80	V
			3.0V	2.88	3.0	3.12	V
		$3.0V < V_{IN} < V_{OUT}$, $I_{OUT}=100mA$	3.3V	3.16	3.3	3.43	V
			4.0V	3.84	4.0	4.16	V
			4.5V	4.32	4.5	4.68	V
	$2.7V < V_{IN} < 3.0V$, $I_{OUT}=40mA$, $3.1V < V_{IN} < V_{OUT}$, $I_{OUT}=80mA$, $3.0V < V_{IN} < V_{OUT}$, $I_{OUT}=40mA$	5.0V	4.80	5.0	5.20	V	
5.5V		5.28	5.5	5.72	V		
I_{CC}	Operating Current	$V_{IN}=5V$, Active, NoLoad Current		1.25	2	mA	
I_{SHDN}	Shutdown Current	EN=0			1.0	uA	
I_{OUT}	Maximum Output Current	$3.0V < V_{IN} < 5V$	100			mA	
η	Efficiency	$V_{IN}=3.0V$, $I_{OUT}=100mA$, Output=5.0V		82		%	
V_{ENH}	EN Input Voltage Hight		1.4			V	
V_{ENL}	EN Input Voltage Low				0.4		
I_{EN}	EN Input Bias Current		-1.0		1.0	uA	
TSS	Charge Pump Soft-Start Time			250		us	
FCLK	Charge Pump Clock Frequency			500		KHz	

Functional Description

The T6319A regulated charge pump provides a regulated output voltage for input voltages ranging from less than the output to greater than the output. This is accomplished by automatic mode switching within the device.

PROTECTION

The regulator has thermal shutdown circuitry that protects it from damage caused by overload conditions. The thermal protection circuitry disables the output when the junction temperature reached approximately 140°C, allowing the device to cool. When the junction temperature cools to approximately 130°C, the output circuitry is automatically reenabled. Continuously running the regulator into thermal shutdown can degrade reliability.

SHUTDOWN MODE

A control pin on the regulator can be used to place the device into an energy-saving shutdown mode. In this mode, the output is disconnected from the input as long as V_{IN} is greater than or equal to minimum V_{IN} .

Charge Pump Efficiency

The core of the T6319A is a regulated output voltage doubling charge pump. The efficiency (η) or an ideal voltage doubling charge pump can typically be expressed as the output power divided by the input power:

$$\eta = P_{OUT}/P_{IN}$$

In addition, with an ideal voltage doubling charge pump, the output current may be expressed as half the input current. The expression to define the ideal efficiency (η) can be rewritten as:

$$\begin{aligned}\eta &= P_{OUT}/P_{IN} = V_{OUT} \times I_{OUT} / V_{IN} \times 2I_{OUT} \\ &= V_{OUT} / 2V_{IN}\end{aligned}$$

Capacitor Selection

The input capacitor stabilizes the input voltage and minimizes the peak current ripple from the source. The value of the capacitor depends on the impedance of the input source used. Small ESR (Equivalent Series Resistance) ceramic capacitor with value of 1uF to 10uF would be suitable.

The output capacitor is used to sustain the output voltage when the internal MOSFET is switched on and smoothing the ripple voltage. The larger the output ripple, the larger the line regulation, which means the LED current changes if the input voltage changes. Low ESR capacitor should be used to reduce output ripple voltage. Use a 1uF to 10uF ceramic output capacitor with about 50mOhm to 150mOhm ESR to provide stable switching and good line regulation.

Layout Considerations

High switching frequencies make PC board layout a very important part of design. Good design minimizes excessive EMI and voltage gradients in the ground plane, both of which can result in instability or regulation errors.

Input filter capacitor, and output filter capacitor as close to the device as possible, and keep their traces short, direct, and wide to reduce power loss so as to improve efficiency. Connect their ground pins at a single common node in a star ground configuration, or at a full ground plane.

The output capacitor should be placed close to the output terminals to obtain better smoothing effect on the output ripple.

APPLICATION INFORMATION

White LED Backlight Driver

LED Selection:

In applications where the T6319A is utilized as a white LED backlight driver, LEDs with forward voltages up to 5.5V may be used. The T6319A is available in 8 regulated output voltage versions: 2.5V ~ 5.5V. The output voltage option selected will determine the maximum LED forward voltage that can be driven. The trade-off for the lower 4.5V output voltage version is the device's ability to supply greater output current. Refer to the "Output Voltage vs. Output Current" curves in the Typical Characteristics section of this datasheet to determine the best T6319A output voltage option based on the requirements of given application.

LED Ballast Resistors:

To set the maximum brightness of white LEDs connected in parallel from a voltage source supply, ballast resistor connected between each LED cathode and ground is required. Refer to the application schematic in below Figure. The maximum brightness is determined by the forward current(I_F) through the respective LED for a given forward voltage(V_F). The typical forward voltage of a specific LED is usually stated in the typical characteristics of the given LED manufacturer's datasheet. The correct ballast resistor value can be determined by the following equation:

$$R_B = (V_{OUT} - V_F) / I_F$$

Where: R_B =Ballast resistor value in ohms

V_{OUT} =Regulated charge pump output voltage

V_F =LED forward voltage at the desired forward current

I_F =Desired LED forward current

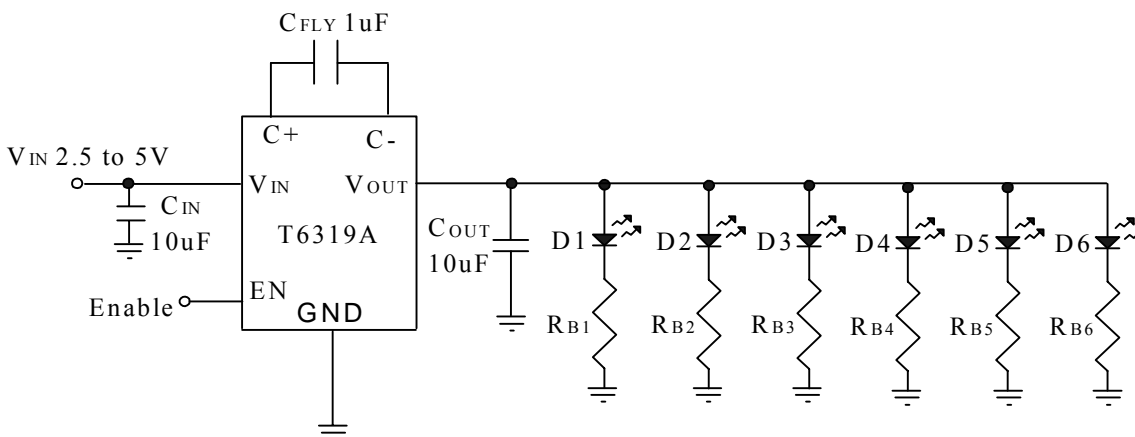

Flash LED Driver

The T6319A can source 250mA for pulsed loads up to 500ms from an input supply as low as 3.3V. This makes the device well suited for low-cost flash LED driver applications in portable products. Typically the 4.5V output version of the T6319A should be selected for photo-flash LED applications, as it can maintain better voltage regulation at higher pulsed load current levels (refer to figure “Flash LED Application”). The limitation of this option is that the greatest flash LED forward voltage (V_F) that can be driven is 4.5V at the maximum set forward current (I_F) for the application. Flash LEDs with forward voltage (V_F) levels up to 5.0V can be driven by the T6319A 5.0V output option. However, the maximum current for a 500ms pulse will be reduced. Refer to the Typical Characteristics curves for peak output current levels for a given minimum input voltage.

The forward current (I_F) through the flash LED may be determined with the use of a series ballast resistor. The typical forward voltage (V_F) for the flash LED in a given application should be derived from the LED manufacturer's datasheet for the desired forward current (I_F) of the flash application. Once the forward current has been determined, the flash ballast resistor can be calculated using the following equation:

$$R_F = (V_{OUT} - V_F) / I_F$$

Where: R_F = Flash ballast resistor value in ohms
 V_{OUT} = Regulated charge pump output voltage (typically 4.5V)
 V_F = Flash LED forward voltage at the desired forward current
 I_F = Desired LED forward current

The flash LED function can be controlled by the T6319A enable pin in most applications. The device start-up time into maximum load is about 200µs, this eliminating the need for pre-flash control synchronization. If “light” or “movie” mode is also needed along with the flash function, this can be accomplished with the addition of a second ballast resistor with a flash function gating MOSFET switch as shown in Figure “Flash LED Driver with Gated Flash Application”. Refer to the following equations for the calculation of flash and light resistors, R_F and R_L.

$$R_L = (V_{OUT} - V_F) / I_F$$

Where: R_L = Light mode ballast resistor value in ohms
 V_{OUT} = Regulated charge pump output voltage (typically 4.5V)
 V_F = Flash LED forward voltage at the desired forward current
 I_F = Desired LED forward current in “light” mode

$$R_F = [(V_{OUT} - V_F) / I_F] - R_{DS}$$

Where: R_F = Flash ballast resistor value in ohms
 V_{OUT} = Regulated charge pump output voltage (typically 4.5V)
 V_F = Flash LED forward voltage at the desired forward current
 I_F = Desired LED forward current
 R_{DS} = flash gating MOSFET on resistance

Application Circuits

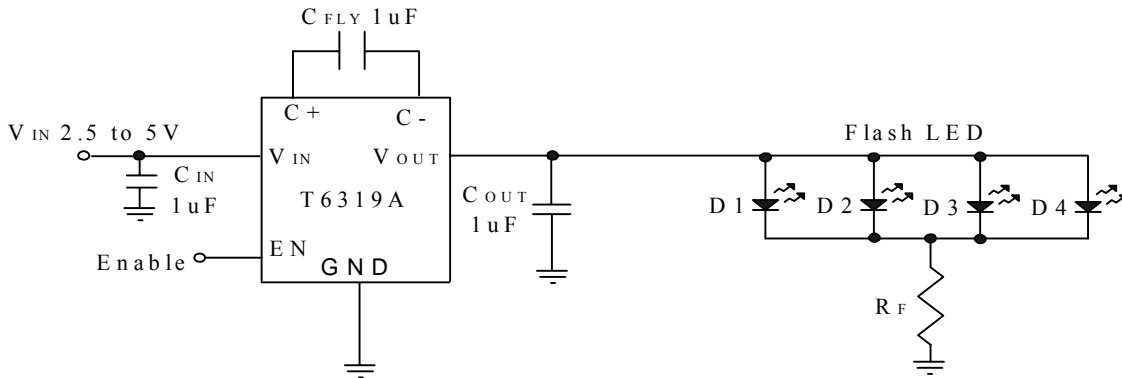

Flash LED Application

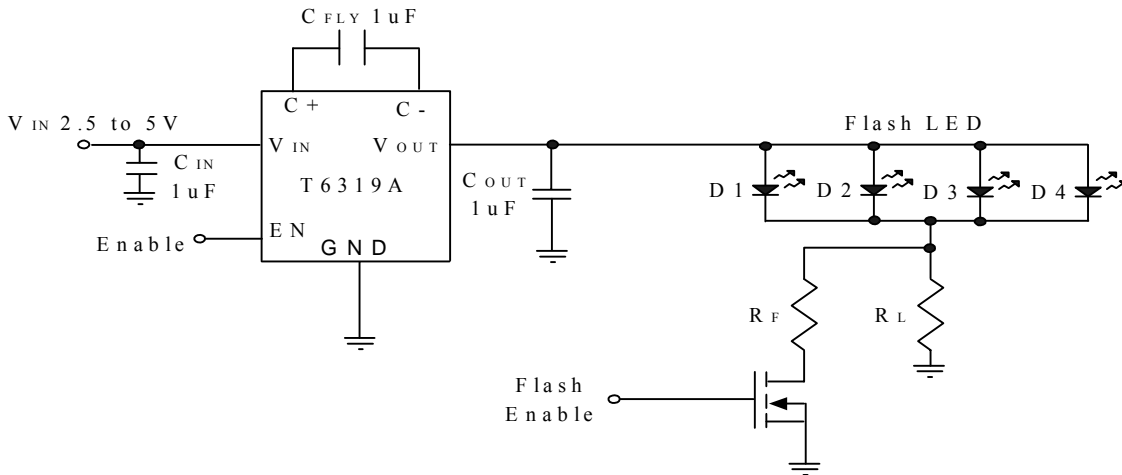

Flash LED Driver with Gated Flash Application

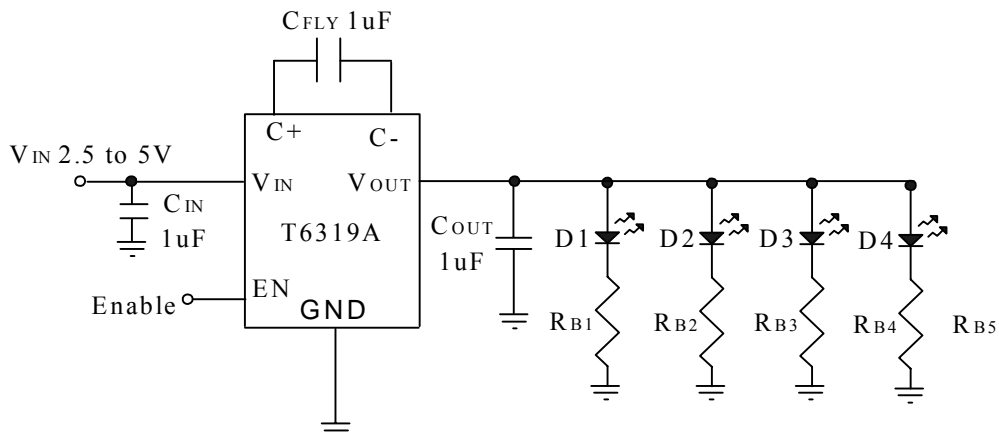

White LED Backlighting Application

PACKAGE DIMENSIONS

SOT23-6

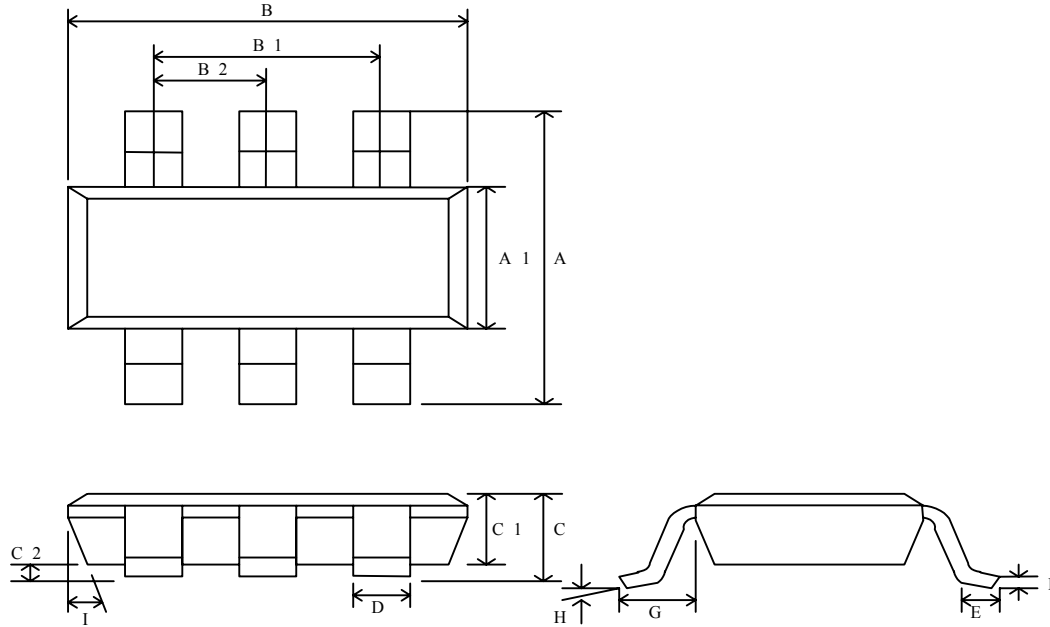

Symbol	Dimension in mm			Dimension in inch		
	Min.	Typ.	Max.	Min.	Typ.	Max.
A	2.60	2.80	3.00	0.102	0.110	0.118
A1	1.40	1.575	1.60	0.055	0.062	0.063
B	2.70	2.85	3.00	0.106	0.112	0.118
B1		1.90(BSC)			0.075(BSC)	
B2		0.95(BSC)			0.037(BSC)	
C	0.95	1.20	1.45	0.037	0.047	0.057
C1	0.90	1.10	1.30	0.035	0.043	0.051
C2	0	0.075	0.150	0	0.003	0.06
D		0.40			0.015	
E	0.30	0.45	0.60	0.012	0.018	0.023
F	0.08	0.15	0.22	0.003	0.006	0.009
G		0.60(REF)				
H				0~8°		
I	5~15°			5~15°		