

PIGTAIL INTEGRATED INGAAs PIN PHOTODIODE ARRAY

PIPA Series

Product Description

Oplink's Pigtail Integrated Photodiode Array (PIPA) is a compact, multi-channel power-monitoring device. It increases module design flexibility and efficiency by significantly reducing the number of assembly components and facilitating fiber management.

Easily mounted on a PCB, Oplink's standard 12/14-pin package provides power monitoring for up to ten channels. Applications include DWDM channel power monitoring, optical network switching/protection monitoring, re-configurable optical add/drop multiplexers, and gain/attenuation monitoring in amplifier systems.

Oplink can provide customized designs to meet specialized feature applications. Also, Oplink offers modular assemblies that integrate other components to form a full function module or subsystem.



Performance Specification

Parameters		Specification	Unit
Operating Wavelength Range		1260~1360 1510~1610	nm
Optical	Return Loss (exclude connector)	>40	dB
Monitoring	Responsivity (relative to nominal power at input port)	>0.75 >0.8	A/W
	Responsivity Temperature Dependence (@1310nm or 1550nm)	<0.2	dB
	Responsivity Polarization Dependence	<0.1	dB
PD	PD Dark Current (@ 70°C, -5V bias)	0.5G Bandwidth	<10 nA
		2.0G Bandwidth	<2.5 nA
	Reverse Voltage	<20	V
	Forward Current	<10	mA
Conditions	Input Optical Power	<4	dBm
	Operating Temperature Range (<85%RH, Non-condensing)	-5 to +70	°C
	Storage Temperature Range (<85%RH, Non-condensing)	-40 to -85	°C

Notes:
1) Excluding connectors.

Features

- ◆ Standard, 12/14-pin package easily mounted on a PCB
- ◆ 4, 8 and 10 channel configurations
- ◆ Wide operating wavelength range
- ◆ Low dark current
- ◆ High temperature stability

Applications

- ◆ DWDM channel monitoring
- ◆ Optical network switch/protection monitoring
- ◆ Re-configurable optical add/drop multiplexers
- ◆ Gain/attenuation monitoring in amplifier systems
- ◆ EDFAs and Raman amplifiers

Mechanical Drawing / Package Dimensions (dimension in mm)

1) 4-ch PIPA

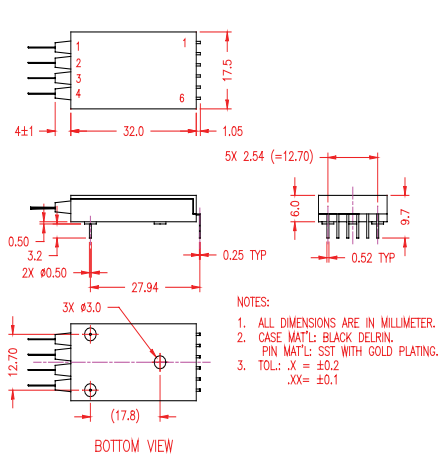

2) 8-ch PIPA

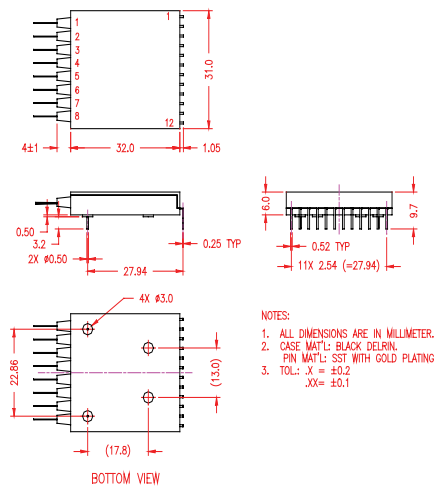

3) 10-ch PIPA

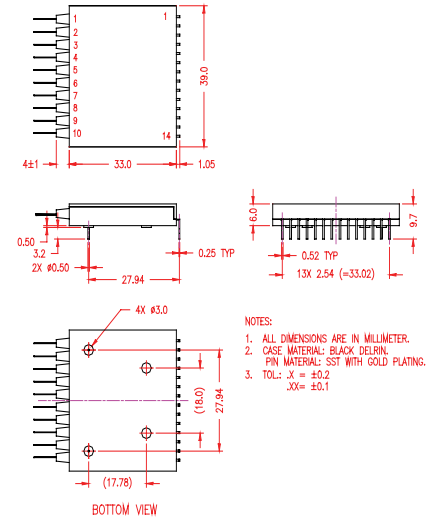

Electrical Pin Assignment		
Pin#:	Common Cathode Assignment	Common Anode Assignment
Pin1:	Common Cathode for Ch1 & 2	Common Anode for Ch1 & 2
Pin2:	Anode Ch1	Cathode Ch1
Pin3:	Anode Ch2	Cathode Ch2
Pin4:	Common Cathode for Ch3 & 4	Common Anode for Ch3 & 4
Pin5:	Anode Ch3	Cathode Ch3
Pin6:	Anode Ch4	Cathode Ch4

Electrical Pin Assignment		
Pin#:	Common Cathode Assignment	Common Anode Assignment
Pin1:	Common Cathode for Ch1 & 2	Common Anode for Ch1 & 2
Pin2:	Anode Ch1	Cathode Ch1
Pin3:	Anode Ch2	Cathode Ch2
Pin4:	Common Cathode for Ch3 & 4	Common Anode for Ch3 & 4
Pin5:	Anode Ch3	Cathode Ch3
Pin6:	Anode Ch4	Cathode Ch4
Pin7:	Anode Ch5	Cathode Ch5
Pin8:	Common Cathode for Ch5 & 6	Common Anode for Ch5 & 6
Pin9:	Anode Ch6	Cathode Ch6
Pin10:	Anode Ch7	Cathode Ch7
Pin11:	Common Cathode for Ch7 & 8	Common Anode for Ch7 & 8
Pin12:	Anode Ch8	Cathode Ch8

Electrical Pin Assignment		
Pin#:	Common Cathode Assignment	Common Anode Assignment
Pin1:	Common Cathode for Ch1 to 4	Common Anode for Ch1 to 4
Pin2:	Anode Ch1	Cathode Ch1
Pin3:	Anode Ch2	Cathode Ch2
Pin4:	Anode Ch3	Cathode Ch3
Pin5:	Anode Ch4	Cathode Ch4
Pin6:	Anode Ch5	Cathode Ch5
Pin7:	Common Cathode for Ch5 to 8	Common Anode for Ch5 to 8
Pin8:	Anode Ch6	Cathode Ch6
Pin9:	Anode Ch7	Cathode Ch7
Pin10:	Anode Ch8	Cathode Ch8
Pin11:	Anode Ch9	Cathode Ch9
Pin12:	Common Cathode for Ch9 & 10	Common Anode for Ch9 & 10
Pin13:	Anode Ch10	Cathode Ch10
Pin14:	Not connected	Not connected

Ordering Information

Oplink can provide a remarkable range of customized optical solutions. For detail, please contact Oplink's OEM design team or account manager for your requirements and ordering information (510) 933-7200.

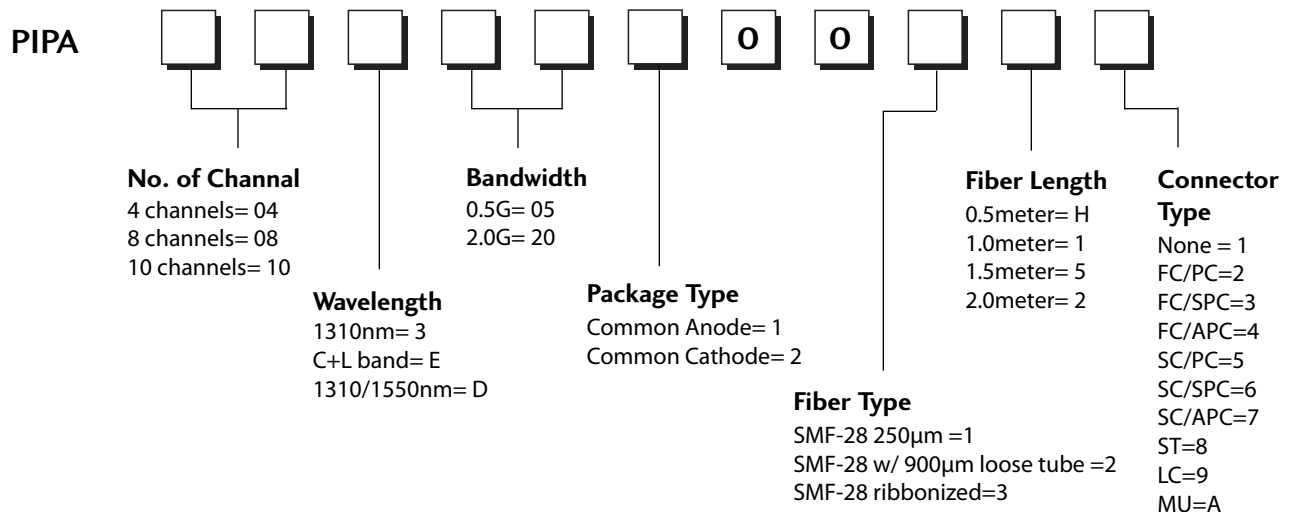

RoHS:

- PIPA is RoHS 5 compliant (RoHS permitted Lead in solder exemption is applied).
- Add "G" to the end of the above PN for RoHS 6 Requirement.