



**SANYO Semiconductors**

# DATA SHEET

## LC87F1JJ4B — CMOS IC FROM 192K byte, RAM 20480 byte on-chip **8-bit 1-chip Microcontroller with USB-host controller**

### Overview

The LC87F1JJ4B is an 8-bit microcomputer that, centered around a CPU running at a minimum bus cycle time of 83.3ns, integrates on a single chip a number of hardware features such as 192K-byte flash ROM (onboard programmable), 20480-byte RAM, an on-chip debugger, a sophisticated 16-bit timer/counter (may be divided into 8-bit timers), a 16-bit timer (may be divided into 8-bit timers or PWMs), four 8-bit timers with a prescaler, a base timer serving as a realtime clock, 3 channels of synchronous SIO interface with automatic data transfer capabilities, an asynchronous/synchronous SIO interface, a UART interface (full duplex), a full-speed USB interface (host control function), an 8-bit 12-channel AD converter, 2 channels of 12-bit PWM, a system clock frequency divider, an infrared remote control receiver circuit, and a 41-source 10-vector interrupt feature.

### Features

#### ■Flash ROM

- Capable of on-board programming with a wide range of supply voltages: 3.0 to 5.5V
- Block-erasable in 128 byte units
- Writes data in 2-byte units
- 196608 × 8 bits

#### ■RAM

- 20480 × 9 bits

#### ■Bus Cycle Time

- 83.3ns (When CF=12MHz)

Note: The bus cycle time here refers to the ROM read speed.

\* This product is licensed from Silicon Storage Technology, Inc. (USA), and manufactured and sold by SANYO Semiconductor Co., Ltd.

■ Any and all SANYO Semiconductor Co.,Ltd. products described or contained herein are, with regard to "standard application", intended for the use as general electronics equipment (home appliances, AV equipment, communication device, office equipment, industrial equipment etc.). The products mentioned herein shall not be intended for use for any "special application" (medical equipment whose purpose is to sustain life, aerospace instrument, nuclear control device, burning appliances, transportation machine, traffic signal system, safety equipment etc.) that shall require extremely high level of reliability and can directly threaten human lives in case of failure or malfunction of the product or may cause harm to human bodies, nor shall they grant any guarantee thereof. If you should intend to use our products for applications outside the standard applications of our customer who is considering such use and/or outside the scope of our intended standard applications, please consult with us prior to the intended use. If there is no consultation or inquiry before the intended use, our customer shall be solely responsible for the use.

■ Specifications of any and all SANYO Semiconductor Co.,Ltd. products described or contained herein stipulate the performance, characteristics, and functions of the described products in the independent state, and are not guarantees of the performance, characteristics, and functions of the described products as mounted in the customer's products or equipment. To verify symptoms and states that cannot be evaluated in an independent device, the customer should always evaluate and test devices mounted in the customer's products or equipment.

**SANYO Semiconductor Co., Ltd.**

[www.semiconductor-sanyo.com/network](http://www.semiconductor-sanyo.com/network)

# LC87F1JJ4B

## ■ Minimum Instruction Cycle Time (tCYC)

- 250ns (When CF=12MHz)

## ■ Ports

- I/O ports

Ports whose I/O direction can be designated in 1-bit units 28 (P10 to P17, P20 to P27, P30 to P34, P70 to P73, PWM0, PWM1, XT2)

Ports whose I/O direction can be designated in 4-bit units 8 (P00 to P07)

- USB ports 2 (UHD+, UHD-)
- Dedicated oscillator ports 2 (CF1, CF2)
- Input-only port (also used for oscillation) 1 (XT1)
- Reset pin 1 (RES)
- Power supply pins 6 (VSS1 to VSS3, VDD1 to VDD3)

## ■ Timers

- Timer 0: 16-bit timer/counter with 2 capture registers.

Mode 0: 8-bit timer with an 8-bit programmable prescaler (with two 8-bit capture registers) × 2 channels

Mode 1: 8-bit timer with an 8-bit programmable prescaler (with two 8-bit capture registers) + 8-bit counter (with two 8-bit capture registers)

Mode 2: 16-bit timer with an 8-bit programmable prescaler (with two 16-bit capture registers)

Mode 3: 16-bit counter (with two 16-bit capture registers)

- Timer 1: 16-bit timer/counter that supports PWM/toggle outputs

Mode 0: 8-bit timer with an 8-bit prescaler (with toggle outputs) + 8-bit timer/counter with an 8-bit prescaler (with toggle outputs)

Mode 1: 8-bit PWM with an 8-bit prescaler × 2 channels

Mode 2: 16-bit timer/counter with an 8-bit prescaler (with toggle outputs) (toggle outputs also possible from lower-order 8 bits)

Mode 3: 16-bit timer with an 8-bit prescaler (with toggle outputs) (lower-order 8 bits may be used as PWM outputs)

- Timer 4: 8-bit timer with a 6-bit prescaler
- Timer 5: 8-bit timer with a 6-bit prescaler
- Timer 6: 8-bit timer with a 6-bit prescaler (with toggle outputs)
- Timer 7: 8-bit timer with a 6-bit prescaler (with toggle outputs)
- Base timer

1) The clock is selectable from the subclock (32.768kHz crystal oscillation), system clock, and timer 0 prescaler output.

2) Interrupts programmable in 5 different time schemes

## ■ SIO

- SIO0: Synchronous serial interface

1) LSB first/MSB first mode selectable

2) Transfer clock cycle: 4/3 to 512/3 tCYC

3) Automatic continuous data transmission (1 to 256 bits, specifiable in 1-bit units) (Suspension and resumption of data transmission possible in 1 byte units)

- SIO1: 8-bit asynchronous/synchronous serial interface

Mode 0: Synchronous 8-bit serial I/O (2- or 3-wire configuration, 2 to 512 tCYC transfer clocks)

Mode 1: Asynchronous serial I/O (half-duplex, 8 data bits, 1 stop bit, 8 to 2048 tCYC baudrates)

Mode 2: Bus mode 1 (start bit, 8 data bits, 2 to 512 tCYC transfer clocks)

Mode 3: Bus mode 2 (start detect, 8 data bits, stop detect)

- SIO4: Synchronous serial interface

1) LSB first/MSB first mode selectable

2) Transfer clock cycle: 4/3 to 1020/3 tCYC

3) Automatic continuous data transmission (1 to 8192 bytes, specifiable in 1 byte units) (Suspension and resumption of data transmission possible in 1 byte units or in word units)

4) Auto-start-on-falling-edge function

5) Clock polarity selectable

6) CRC16 calculator circuit built in

Continued on next page.

Continued from preceding page.

- SIO9: Synchronous serial interface
  - 1) LSB first/MSB first mode selectable
  - 2) Transfer clock cycle: 4/3 to 1020/3 tCYC
  - 3) Automatic continuous data transmission (1 to 8192 bytes, specifiable in 1 byte units)  
(Suspension and resumption of data transmission possible in 1 byte units or word units)
  - 4) Auto-start-on-falling-edge function
  - 5) Clock polarity selectable
  - 6) CRC16 calculator circuit built in

■ Full Duplex UART

- 1) Data length: 7/8/9 bits selectable
- 2) Stop bits: 1 bit (2 bits in continuous transmission mode)
- 3) Baud rate: 16/3 to 8192/3 tCYC

■ AD Converter: 8 bits × 12 channels

■ PWM: Multifrequency 12-bit PWM × 2 channels

■ Infrared Remote Control Receiver Circuit

- 1) Noise rejection function (noise filter time constant: Approx. 120μs when the 32.768kHz crystal oscillator is selected as the base clock)
- 2) Supports data encoding systems such as PPM (Pulse Position Modulation) and Manchester encoding.
- 3) X'tal HOLD mode release function

■ USB Interface (host control function)

- 1) Compliant with full-speed (12M bps) specifications
- 2) Supports 4 transfer types (control transfer, bulk transfer, interrupt transfer, and isochronous transfer).

■ Audio Interface

- 1) Sampling frequency (fs): 8kHz/11.025kHz/12kHz/16kHz/22.05kHz/24kHz/32kHz/44.1kHz/48kHz
- 2) Master clock frequency: 256fs/384fs
- 3) Bit clock selectable: 48fs/64fs
- 4) Data bit length: 16/18/20/24 bits
- 5) LSB first/MSB first mode selectable
- 6) Left-justification/right-justification/I2S format selectable

■ Watchdog Timer

- Watchdog timer using external RC circuitry
- Interrupt and reset signals selectable

■ Clock Output Function

- 1) Can output a clock with a clock rate of 1/1, 1/2, 1/4, 1/8, 1/16, 1/32, or 1/64 of the source oscillator clock selected as the system clock.
- 2) Can output the source oscillation clock for the subclock.

# LC87F1JJ4B

## ■ Interrupts

- 41 sources, 10 vector addresses

- 1) Provides three levels (low (L), high (H), and highest (X)) of multiplex interrupt control. Any interrupt requests of the level equal to or lower than the current interrupt are not accepted.
- 2) When interrupt requests to two or more vector addresses occur at the same time, the interrupt of the highest level takes precedence over the other interrupts. For interrupts of the same level, the interrupt into the smallest vector address takes precedence.

No.	Vector Address	Level	Interrupt Source
1	00003H	X or L	INT0
2	0000BH	X or L	INT1
3	00013H	H or L	INT2/T0L/INT4/UHC bus active/remote control signal receive
4	0001BH	H or L	INT3/INT5/base timer
5	00023H	H or L	T0H/INT6/UHC device attach/UHC device detach/UHC resume
6	0002BH	H or L	T1L/T1H/INT7/SIO9/AIF start
7	00033H	H or L	SIO0/UART1 receive
8	0003BH	H or L	SIO1/SIO4/UART1 transmit/AIF end
9	00043H	H or L	ADC/T6/T7/UHC-ACK/UHC-NAK/UHC error/UHC-STALL
10	0004BH	H or L	Port 0/PWM0/PWM1/T4/T5/UHC-SOF/DMCOPY/AIF error

- Priority levels  $X > H > L$
- Of interrupts of the same level, the one with the smallest vector address takes precedence.

## ■ Subroutine Stack Levels: 10240 levels maximum (The stack is allocated in RAM.)

## ■ High-speed Multiplication/Division Instructions

- 16 bits  $\times$  8 bits (5 tCYC execution time)
- 24 bits  $\times$  16 bits (12 tCYC execution time)
- 16 bits  $\div$  8 bits (8 tCYC execution time)
- 24 bits  $\div$  16 bits (12 tCYC execution time)

## ■ Oscillation and PLL Circuits

- RC oscillation circuit (internal): For system clock
- CF oscillation circuit: For system clock
- Crystal oscillation circuit: For system clock, and realtime clock
- PLL circuit (internal): For USB interface (see Fig.5) and audio interface (see Fig. 6)

## LC87F1JJ4B

### ■ Standby Function

- HALT mode: Halts instruction execution while allowing the peripheral circuits to continue operation.
  - 1) Oscillation is not halted automatically.
  - 2) There are three ways of releasing the HALT mode.
    - (1) Setting the reset pin to the lower level.
    - (2) System resetting by watchdog timer
    - (3) Generating an interrupt
- HOLD mode: Suspends instruction execution and the operation of the peripheral circuits.
  - 1) The PLL base clock generator, CF, RC and crystal oscillators automatically stop operation.
  - 2) There are five ways of releasing the HOLD mode.
    - (1) Setting the reset pin to the lower level
    - (2) System resetting by watchdog timer
    - (3) Having an interrupt source established at one of the INT0, INT1, INT2, INT4, and INT5 pins
      - \* The INT0 and INT1 pins must be configured only for level detection.
    - (4) Having an interrupt source established at port 0
    - (5) Having an bus active interrupt source established in the USB host control circuit
- X'tal HOLD mode: Suspends instruction execution and the operation of the peripheral circuits except the base timer.
  - 1) The PLL base clock generator, CF and RC oscillator automatically stop operation.
  - 2) The state of crystal oscillation established when the X'tal HOLD mode is entered is retained.
  - 3) There are seven ways of releasing the X'tal HOLD mode.
    - (1) Setting the reset pin to the low level
    - (2) System resetting by watchdog timer
    - (3) Having an interrupt source established at one of the INT0, INT1, INT2, INT4, and INT5 pins
      - \* The INT0 and INT1 pins must be configured only for level detection.
    - (4) Having an interrupt source established at port 0
    - (5) Having an interrupt source established in the base timer circuit
    - (6) Having an bus active interrupt source established in the USB host control circuit
    - (7) Having an interrupt source established in the infrared remote controller receiver circuit

### ■ Package Form

- SQFP48(7×7): Lead-free type

### ■ Development Tools

- On-chip debugger: TCB87- type B + LC87F1JJ4B

### ■ Flash ROM Programming Boards

Package	Programming board
SQFP48(7×7)	W87F55256SQ

### ■ Flash ROM Programmer

Maker		Model	Supported Version	Device
Flash Support Group, Inc. (FSG)	Single	AF9708/ AF9709/AF9709B/AF9709C (including Ando Electric Co., Ltd. models)	Rev. 03.12 or later	LC87F1JJ2A
Flash Support Group, Inc. (FSG) + SANYO(Note 1)	Onboard single/ganged	AF9101/AF9103(main unit) (FSG) SIB87(interface driver) (SANYO)	(Note 2)	LC87F1JJ2A
SANYO	Single/ganged	SKK/SKK Type B (SANYO FWS)	Application version: 1.04 or later	LC87F1JJ4
	Onboard single/ganged	SKK-DBG Type B (SANYO FWS)	Chip data version: 2.17 or later	

Note 1: PC-less standalone onboard programming is possible using the FSG onboard programmer (AF9101/AF9103) and the serial interface driver (SIB87) provided by SANYO in pair.

Note 2: Dedicated programming device and program are required depending on the programming conditions. Contact SANYO or FSG if you have any questions or difficulties regarding this matter.

# LC87F1JJ4B

## Package Dimensions

unit : mm (typ)

3163B

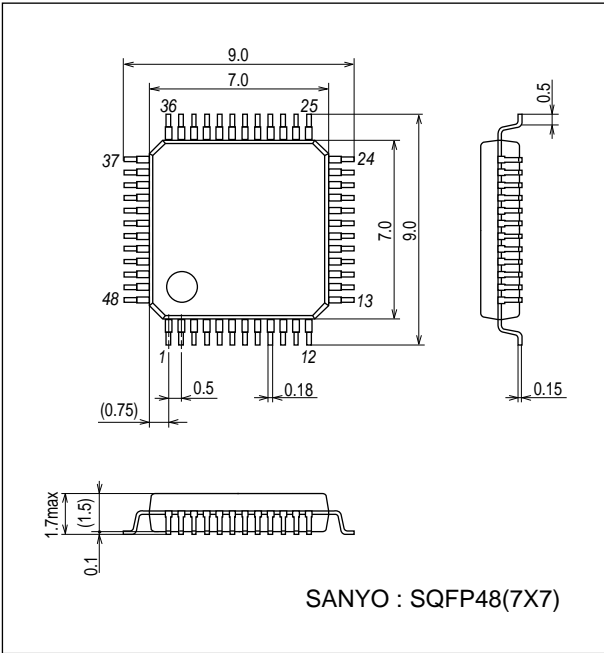

## Pin Assignment

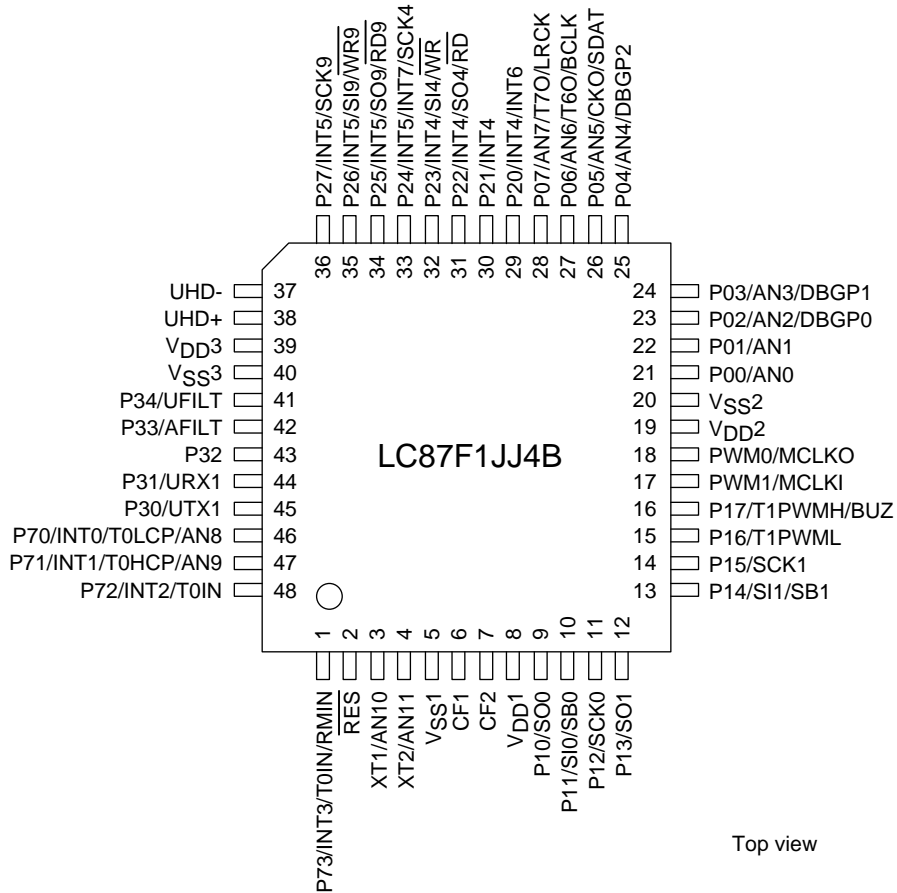

SANYO: SQFP48(7x7) "Lead-free type"

## LC87F1JJ4B

SQFP48	NAME
1	P73/INT3/T0IN/RMIN
2	$\overline{\text{RES}}$
3	XT1/AN10
4	XT2/AN11
5	V <sub>SS1</sub>
6	CF1
7	CF2
8	V <sub>DD1</sub>
9	P10/SO0
10	P11/SI0/SB0
11	P12/SCK0
12	P13/SO1
13	P14/SI1/SB1
14	P15/SCK1
15	P16/T1PWML
16	P17/T1PWMH/BUZ
17	PWM1/MCLKI
18	PWM0/MCLKO
19	V <sub>DD2</sub>
20	V <sub>SS2</sub>
21	P00/AN0
22	P01/AN1
23	P02/AN2/DBGP0
24	P03/AN3/DBGP1

SQFP48	NAME
25	P04/AN4/DBGP2
26	P05/AN5/CKO/SDAT
27	P06/AN6/T6O/BCLK
28	P07/AN7/T7O/LRCK
29	P20/INT4/INT6
30	P21/INT4
31	P22/INT4/SO4/ $\overline{\text{RD}}$
32	P23/INT4/SI4/ $\overline{\text{WR}}$
33	P24/INT5/INT7/SCK4
34	P25/INT5/SO9/ $\overline{\text{RD9}}$
35	P26/INT5/SI9/ $\overline{\text{WR9}}$
36	P27/INT5/SCK9
37	UHD-
38	UHD+
39	V <sub>DD3</sub>
40	V <sub>SS3</sub>
41	P34/UFILT
42	P33/AFILT
43	P32
44	P31/URX1
45	P30/UTX1
46	P70/INT0/T0LCP/AN8
47	P71/INT1/T0HCP/AN9
48	P72/INT2/T0IN

System Block Diagram

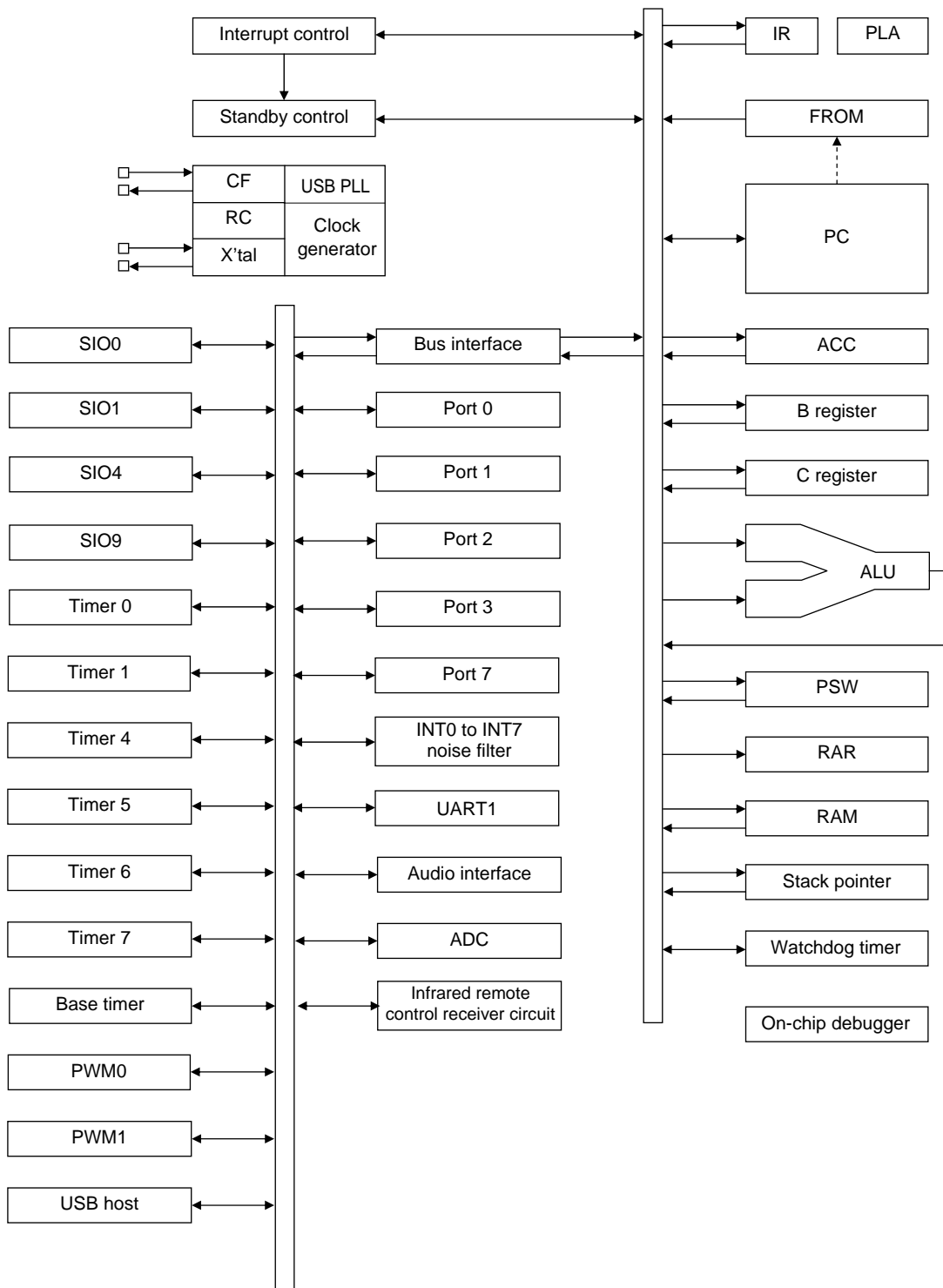





# LC87F1JJ4B

Continued from preceding page.

Pin Name	I/O	Description	Option																														
Port 7 P70 to P73	I/O	<ul style="list-style-type: none"> <li>• 4-bit I/O ports</li> <li>• I/O specifiable in 1-bit units</li> <li>• Pull-up resistors can be turned on and off in 1-bit units.</li> <li>• Pin functions</li> </ul> P70: INT0 input/HOLD release input/timer 0L capture input/watchdog timer output P71: INT1 input/HOLD release input/timer 0H capture input P72: INT2 input/HOLD release input/timer 0 event input/timer 0L capture input/ high speed clock counter input P73: INT3 input (input with noise filter)/timer 0 event input/timer 0H capture input/ infrared remote control receiver input AD converter input ports: AN8(P70), AN9(P71) Interrupt acknowledge types <table border="1" style="margin-left: 20px;"> <thead> <tr> <th></th> <th>Rising</th> <th>Falling</th> <th>Rising &amp; Falling</th> <th>H level</th> <th>L level</th> </tr> </thead> <tbody> <tr> <td>INT0</td> <td>enable</td> <td>enable</td> <td>disable</td> <td>enable</td> <td>enable</td> </tr> <tr> <td>INT1</td> <td>enable</td> <td>enable</td> <td>disable</td> <td>enable</td> <td>enable</td> </tr> <tr> <td>INT2</td> <td>enable</td> <td>enable</td> <td>enable</td> <td>disable</td> <td>disable</td> </tr> <tr> <td>INT3</td> <td>enable</td> <td>enable</td> <td>enable</td> <td>disable</td> <td>disable</td> </tr> </tbody> </table>		Rising	Falling	Rising & Falling	H level	L level	INT0	enable	enable	disable	enable	enable	INT1	enable	enable	disable	enable	enable	INT2	enable	enable	enable	disable	disable	INT3	enable	enable	enable	disable	disable	No
	Rising	Falling	Rising & Falling	H level	L level																												
INT0	enable	enable	disable	enable	enable																												
INT1	enable	enable	disable	enable	enable																												
INT2	enable	enable	enable	disable	disable																												
INT3	enable	enable	enable	disable	disable																												
PWM0 PWM1	I/O	PWM0, PWM1 output ports General-purpose input port <ul style="list-style-type: none"> <li>• Pin functions</li> </ul> PWM0: Audio interface master clock output PWM1: Audio interface master clock input	No																														
UHD-	I/O	USB data I/O pin UHD-/general-purpose I/O port	No																														
UHD+	I/O	USB data I/O pin UHD+/general-purpose I/O port	No																														
RES	I	Reset pin	No																														
XT1	I	<ul style="list-style-type: none"> <li>• 32.768kHz crystal oscillator input</li> <li>• Pin functions</li> </ul> General-purpose input port AD converter input port: AN10 Must be connected to V <sub>DD1</sub> when not to be used.	No																														
XT2	I/O	<ul style="list-style-type: none"> <li>• 32.768kHz crystal oscillator output</li> <li>• Pin functions</li> </ul> General-purpose input port AD converter input port: AN11 Must be configured for oscillation and kept open if not to be used.	No																														
CF1	I	Ceramic/crystal resonator input	No																														
CF2	O	Ceramic/crystal resonator output	No																														

## Port Output Types

The table below lists the types of port outputs and the presence/absence of a pull-up resistor.

Data can be read into any input port even if it is in the output mode.

Port Name	Option Selected in Units of	Option Type	Output Type	Pull-up Resistor
P00 to P07	1 bit	1	CMOS	Programmable (Note 1)
		2	Nch-open drain	No
P10 to P17 P20 to P27 P30 to P34	1 bit	1	CMOS	Programmable
		2	Nch-open drain	Programmable
P70	-	No	Nch-open drain	Programmable
P71 to P73	-	No	CMOS	Programmable
PWM0, PWM1	-	No	CMOS	No
UHD+, UHD-	-	No	CMOS	No
XT1	-	No	Input only	No
XT2	-	No	32.768kHz crystal resonator output (Nch-open drain when in general-purpose output mode)	No

Note 1: Programmable pull-up resistors for port 0 are controlled in 4 bit units (P00 to 03, P04 to 07).

# LC87F1JJ4B

## User Options

Option Name	Type	Flash ROM Version	Option Selected in Units of	Setting	
Port output type	P00 to P07	○	1 bit	CMOS	
				Nch-open drain	
	P10 to P17	○	1 bit	CMOS	
				Nch-open drain	
	P20 to P27	○	1 bit	CMOS	
				Nch-open drain	
	P30 to P34	○	1 bit	CMOS	
				Nch-open drain	
Program start address	-	○	-	00000h	
				1FE00h	
USB Regulator	USB Regulator	○	-	Use	
				Nonuse	
	USB Regulator (at HOLD mode)	○	-	-	Use
					Nonuse
	USB Regulator (at HALT mode)	○	-	-	Use
					Nonuse

## Power Pin Treatment

Connect the IC as shown below to minimize the noise input to the VDD1 pin and extend the backup period. Be sure to electrically short the VSS1, VSS2, and VSS3 pins.

Example 1: When the microcontroller is in the backup state in the HOLD mode, the power to sustain the high level of output ports is supplied by their backup capacitors.

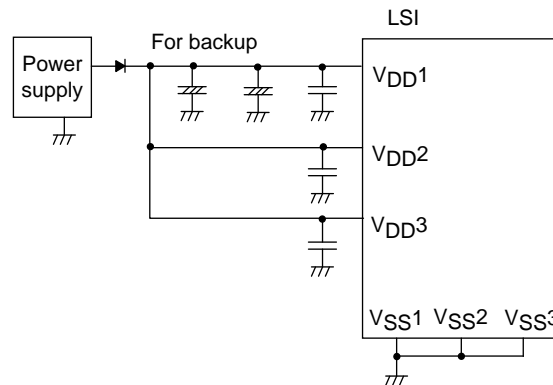

Example 2: The high level output at ports is not sustained and unstable in the HOLD backup mode.

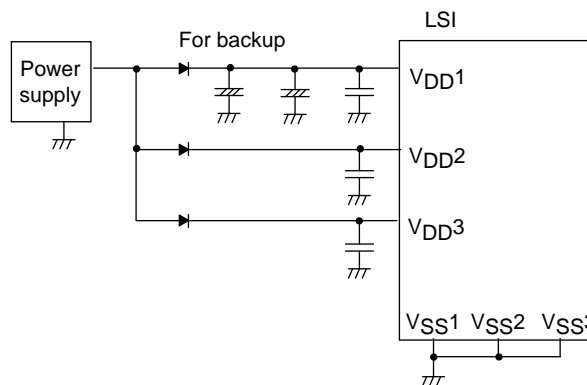

**USB Reference Power Option**

When a voltage 4.5 to 5.5V is supplied to V<sub>DD1</sub> and the internal USB reference voltage circuit is activated, the reference voltage for USB port output is generated. The active/inactive state of the reference voltage circuit can be switched by optional settings. The procedure for marking the optional settings is described below.

		(1)	(2)	(3)	(4)
Option settings	USB regulator	Use	Use	Use	Nonuse
	USB regulator in HOLD mode	Use	Nonuse	Nonuse	Nonuse
	USB regulator in HALT mode	Use	Nonuse	Use	Nonuse
Reference voltage circuit state	Normal mode	Active	Active	Active	Inactive
	HOLD mode	Active	Inactive	Inactive	Inactive
	HALT mode	Active	Inactive	Active	Inactive

- When the USB reference voltage circuit is made inactive, the level of the reference voltage for USB port output is equal to V<sub>DD1</sub>.
- Selection (2) or (3) can be used to set the reference voltage circuit inactive in HOLD or HALT mode.
- When the reference voltage circuit is activated, the current drain increases by approximately 100μA compared with when the reference voltage circuit is inactive.

Circuit example 1: When V<sub>DD1</sub>=V<sub>DD2</sub>=3.3V

- Inactivating the reference voltage circuit (selection (4)).
- Connecting V<sub>DD3</sub> to V<sub>DD1</sub> and V<sub>DD2</sub>.

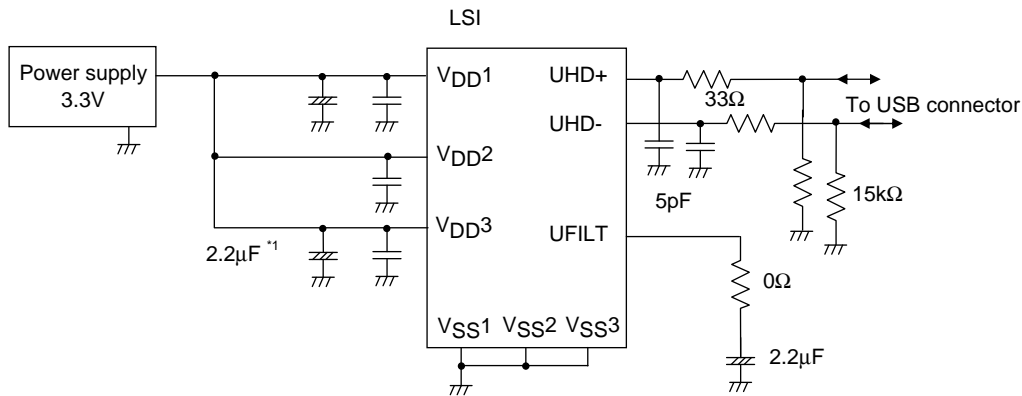

\*1: Needs adjustment on target board.

Circuit example 2: When V<sub>DD1</sub>=V<sub>DD2</sub>=5.0V

- Activating the reference voltage circuit (selection (1)).
- Isolating V<sub>DD3</sub> from V<sub>DD1</sub> and V<sub>DD2</sub>, and connecting capacitor between V<sub>DD3</sub> and V<sub>SS</sub>.

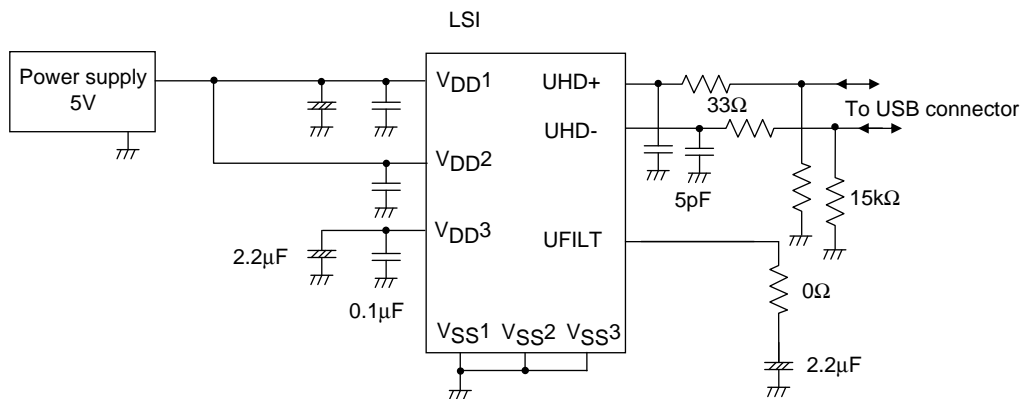

# LC87F1JJ4B

## Absolute Maximum Ratings at Ta = 25°C, VSS1 = VSS2 = VSS3 = 0V

Parameter	Symbol	Pin/Remarks	Conditions	Specification				unit	
				VDD[V]	min	typ	max		
Maximum supply voltage	VDD max	VDD1, VDD2, VDD3	VDD1=VDD2=VDD3		-0.3		+6.5	V	
Input voltage	VI(1)	XT1, CF1			-0.3		VDD+0.3		
Input/output voltage	VI(1)	Ports 0, 1, 2, 3, 7 PWM0, PWM1 XT2			-0.3		VDD+0.3		
High level output current	Peak output current	IOPH(1)	Ports 0, 1, 2	<ul style="list-style-type: none"> <li>When CMOS output type is selected</li> <li>Per 1 applicable pin</li> </ul>		-10		mA	
		IOPH(2)	PWM0, PWM1	Per 1 applicable pin		-20			
		IOPH(3)	Port 3 P71 to P73	<ul style="list-style-type: none"> <li>When CMOS output type is selected</li> <li>Per 1 applicable pin</li> </ul>		-5			
	Average output current (Note 1-1)	IOMH(1)	Ports 0, 1, 2	<ul style="list-style-type: none"> <li>When CMOS output type is selected</li> <li>Per 1 applicable pin</li> </ul>		-7.5			
		IOMH(2)	PWM0, PWM1	Per 1 applicable pin		-15			
		IOMH(3)	Port 3 P71 to P73	<ul style="list-style-type: none"> <li>When CMOS output type is selected</li> <li>Per 1 applicable pin</li> </ul>		-3			
	Total output current	ΣIOAH(1)	Ports 0, 2	Total current of all applicable pins		-25			
		ΣIOAH(2)	Port 1 PWM0, PWM1	Total current of all applicable pins		-25			
		ΣIOAH(3)	Ports 0, 1, 2 PWM0, PWM1	Total current of all applicable pins		-45			
		ΣIOAH(4)	Port 3 P71 to P73	Total current of all applicable pins		-10			
ΣIOAH(5)		UHD+, UHD-	Total current of all applicable pins		-25				
Low level output current	Peak output current	IOPL(1)	P02 to P07 Ports 1, 2 PWM0, PWM1	Per 1 applicable pin			20		
		IOPL(2)	P00, P01	Per 1 applicable pin			30		
		IOPL(3)	Ports 3, 7 XT2	Per 1 applicable pin			10		
	Average output current (Note 1-1)	IOML(1)	P02 to P07 Ports 1, 2 PWM0, PWM1	Per 1 applicable pin				15	
		IOML(2)	P00, P01	Per 1 applicable pin				20	
		IOML(3)	Ports 3, 7 XT2	Per 1 applicable pin				7.5	
	Total output current	ΣIOAL(1)	Ports 0, 2	Total current of all applicable pins				45	
		ΣIOAL(2)	Port 1 PWM0, PWM1	Total current of all applicable pins				45	
		ΣIOAL(3)	Ports 0, 1, 2 PWM0, PWM1	Total current of all applicable pins				80	
		ΣIOAL(4)	Ports 3, 7 XT2	Total current of all applicable pins				15	
ΣIOAL(5)		UHD+, UHD-	Total current of all applicable pins				25		
Allowable power dissipation	Pd max	SQFP48(7×7)	Ta=-40 to +85°C				140	mW	
Operating ambient temperature	Topr				-40		+85	°C	
Storage ambient temperature	Tstg				-55		+125		

Note 1-1: The average output current is an average of current values measured over 100ms intervals.

# LC87F1JJ4B

## Allowable Operating Conditions at Ta = -40°C to +85°C, V<sub>SS1</sub> = V<sub>SS2</sub> = V<sub>SS3</sub> = 0V

Parameter	Symbol	Pin/Remarks	Conditions	Specification				unit
				V <sub>DD</sub> [V]	min	typ	max	
Operating supply voltage (Note 2-1)	V <sub>DD</sub> (1)	V <sub>DD1</sub> =V <sub>DD2</sub> =V <sub>DD3</sub>	0.245μs ≤ tCYC ≤ 200μs		3.0		5.5	V
			0.490μs ≤ tCYC ≤ 200μs Except in onboard programming mode		2.7		5.5	
Memory sustaining supply voltage	V <sub>H</sub> D	V <sub>DD1</sub> =V <sub>DD2</sub> =V <sub>DD3</sub>	RAM and register contents sustained in HOLD mode.		2.0		5.5	
High level input voltage	V <sub>I</sub> H(1)	Ports 0, 1, 2, 3 P71 to P73 P70 port input/ interrupt side PWM0, PWM1		2.7 to 5.5	0.3V <sub>DD</sub> +0.7		V <sub>DD</sub>	
	V <sub>I</sub> H(2)	Port 70 watchdog timer side		2.7 to 5.5	0.9V <sub>DD</sub>		V <sub>DD</sub>	
	V <sub>I</sub> H(3)	XT1, XT2, CF1, RES		2.7 to 5.5	0.75V <sub>DD</sub>		V <sub>DD</sub>	
Low level input voltage	V <sub>I</sub> L(1)	Ports 1, 2, 3 P71 to P73		4.0 to 5.5	V <sub>SS</sub>		0.1V <sub>DD</sub> +0.4	
	V <sub>I</sub> L(2)	P70 port input/ interrupt side		2.7 to 4.0	V <sub>SS</sub>		0.2V <sub>DD</sub>	
	V <sub>I</sub> L(3)	Port 0 PWM0, PWM1		4.0 to 5.5	V <sub>SS</sub>		0.15V <sub>DD</sub> +0.4	
	V <sub>I</sub> L(4)			2.7 to 4.0	V <sub>SS</sub>		0.2V <sub>DD</sub>	
	V <sub>I</sub> L(5)	Port 70 watchdog timer side		2.7 to 5.5	V <sub>SS</sub>		0.8V <sub>DD</sub> -1.0	
	V <sub>I</sub> L(6)	XT1, XT2, CF1, RES		2.7 to 5.5	V <sub>SS</sub>		0.25V <sub>DD</sub>	
Instruction cycle time (Note 2-2)	tCYC			3.0 to 5.5	0.245		200	μs
			Except in onboard programming mode	2.7 to 5.5	0.490		200	
External system clock frequency	FEXCF(1)	CF1	<ul style="list-style-type: none"> <li>• CF2 pin open</li> <li>• System clock frequency division ratio=1/1</li> <li>• External system clock duty =50±5%</li> </ul>	3.0 to 5.5	0.1		12	MHz
			<ul style="list-style-type: none"> <li>• CF2 pin open</li> <li>• System clock frequency division ratio=1/1</li> <li>• External system clock duty =50±5%</li> </ul>	2.7 to 5.5	0.1		6	
Oscillation frequency range (Note 2-3)	FmCF(1)	CF1, CF2	When 12MHz ceramic oscillation See Fig. 1.	3.0 to 5.5		12		MHz
	FmCF(2)	CF1, CF2	When 6MHz ceramic oscillation See Fig. 1.	2.7 to 5.5		6		
	FmRC		Internal RC oscillation	2.7 to 5.5	0.3	1.0	2.0	
	FsX'tal	XT1, XT2	32.768kHz crystal oscillation See Fig. 2.	2.7 to 5.5		32.768		kHz

Note 2-1: V<sub>DD</sub> must be held greater than or equal to 3.0V in the flash ROM onboard programming mode.

Note 2-2: Relationship between tCYC and oscillation frequency is 3/FmCF at a division ratio of 1/1 and 6/FmCF at a division ratio of 1/2.

Note 2-3: See oscillation characteristics examples.

# LC87F1JJ4B

## Electrical Characteristics at Ta = -40°C to +85°C, VSS1 = VSS2 = VSS3 = 0V

Parameter	Symbol	Pin/Remarks	Conditions	Specification				
				VDD[V]	min	typ	max	unit
High level input current	I <sub>IH</sub> (1)	Ports 0, 1, 2, 3 Port 7 $\overline{\text{RES}}$ PWM0, PWM1 UHD+, UHD-	Output disabled Pull-up resistor off V <sub>IN</sub> =V <sub>DD</sub> (Including output Tr's off leakage current)	2.7 to 5.5			1	μA
	I <sub>IH</sub> (2)	XT1, XT2	Input port configuration V <sub>IN</sub> =V <sub>DD</sub>	2.7 to 5.5			1	
	I <sub>IH</sub> (3)	CF1	V <sub>IN</sub> =V <sub>DD</sub>	2.7 to 5.5			15	
Low level input current	I <sub>IL</sub> (1)	Ports 0, 1, 2, 3 Port 7 $\overline{\text{RES}}$ PWM0, PWM1 UHD+, UHD-	Output disabled Pull-up resistor off V <sub>IN</sub> =V <sub>SS</sub> (Including output Tr's off leakage current)	2.7 to 5.5	-1			μA
	I <sub>IL</sub> (2)	XT1, XT2	Input port configuration V <sub>IN</sub> =V <sub>SS</sub>	2.7 to 5.5	-1			
	I <sub>IL</sub> (3)	CF1	V <sub>IN</sub> =V <sub>SS</sub>	2.7 to 5.5	-15			
High level output voltage	V <sub>OH</sub> (1)	Ports 0, 1, 2, 3	I <sub>OH</sub> =-1mA	4.5 to 5.5	V <sub>DD</sub> -1			V
	V <sub>OH</sub> (2)	P71 to P73	I <sub>OH</sub> =-0.4mA	3.0 to 5.5	V <sub>DD</sub> -0.4			
	V <sub>OH</sub> (3)		I <sub>OH</sub> =-0.2mA	2.7 to 5.5	V <sub>DD</sub> -0.4			
	V <sub>OH</sub> (4)		PWM0, PWM1	I <sub>OH</sub> =-10mA	4.5 to 5.5	V <sub>DD</sub> -1.5		
	V <sub>OH</sub> (5)	P05 to P07 (Note 3-1)	I <sub>OH</sub> =-1.6mA	3.0 to 5.5	V <sub>DD</sub> -0.4			
	V <sub>OH</sub> (6)		I <sub>OH</sub> =-1mA	2.7 to 5.5	V <sub>DD</sub> -0.4			
Low level output voltage	V <sub>OL</sub> (1)	P00, P01	I <sub>OL</sub> =30mA	4.5 to 5.5			1.5	V
	V <sub>OL</sub> (2)		I <sub>OL</sub> =5mA	3.0 to 5.5			0.4	
	V <sub>OL</sub> (3)		I <sub>OL</sub> =2.5mA	2.7 to 5.5			0.4	
	V <sub>OL</sub> (4)	Ports 0, 1, 2	I <sub>OL</sub> =10mA	4.5 to 5.5			1.5	
	V <sub>OL</sub> (5)	PWM0, PWM1 XT2	I <sub>OL</sub> =1.6mA	3.0 to 5.5			0.4	
	V <sub>OL</sub> (6)		I <sub>OL</sub> =1mA	2.7 to 5.5			0.4	
	V <sub>OL</sub> (7)	Ports 3, 7	I <sub>OL</sub> =1.6mA	3.0 to 5.5			0.4	
	V <sub>OL</sub> (8)		I <sub>OL</sub> =1mA	2.7 to 5.5			0.4	
Pull-up resistance	R <sub>pu</sub> (1)	Ports 0, 1, 2, 3	V <sub>OH</sub> =0.9V <sub>DD</sub>	4.5 to 5.5	15	35	80	kΩ
	R <sub>pu</sub> (2)	Port 7		2.7 to 4.5	18	50	150	
Hysteresis voltage	V <sub>HYS</sub>	$\overline{\text{RES}}$ Port 1, 2, 3, 7		2.7 to 5.5		0.1V <sub>DD</sub>		V
Pin capacitance	CP	All pins	For pins other than that under test: V <sub>IN</sub> =V <sub>SS</sub> f=1MHz Ta=25°C	2.7 to 5.5		10		pF

Note 3-1: When the CKO system clock output function (P05) or audio interface output function (P05 to P07) is used.

# LC87F1JJ4B

**Serial I/O Characteristics** at Ta = -40°C to +85°C, VSS1 = VSS2 = VSS3 = 0V

## 1. SIO0 Serial I/O Characteristics (Note 4-1-1)

Parameter	Symbol	Pin/ Remarks	Conditions	VDD[V]	Specification					
					min	typ	max	unit		
Serial clock	Input clock	Frequency	tSCK(1)	SCK0(P12)	2.7 to 5.5				tCYC	
		Low level pulse width	tSCKL(1)	See Fig. 9.						2
		High level pulse width	tSCKH(1)							1
			tSCKHA(1a)							1
		tSCKHA(1b)	<ul style="list-style-type: none"> <li>Continuous data transfer mode</li> <li>USB, AIF, SIO4, SIO9, and DMCOPY not used at the same time.</li> <li>See Fig. 9.</li> <li>(Note 4-1-2)</li> </ul>	4						
		tSCKHA(1c)	<ul style="list-style-type: none"> <li>Continuous data transfer mode</li> <li>USB used at the same time.</li> <li>AIF, SIO4, SIO9, and DMCOPY not used at the same time.</li> <li>See Fig. 9.</li> <li>(Note 4-1-2)</li> </ul>	7						
	Output clock	Frequency	tSCK(2)	SCK0(P12)	2.7 to 5.5				tSCK	
		Low level pulse width	tSCKL(2)	<ul style="list-style-type: none"> <li>When CMOS output type is selected</li> <li>See Fig. 9.</li> </ul>						4/3
		High level pulse width	tSCKH(2)	<ul style="list-style-type: none"> <li>Continuous data transfer mode</li> <li>USB, AIF, SIO4, SIO9, and DMCOPY not used at the same time.</li> <li>When CMOS output type is selected</li> <li>See Fig. 9.</li> </ul>						1/2
tSCKHA(2a)	<ul style="list-style-type: none"> <li>Continuous data transfer mode</li> <li>USB, AIF, SIO4, SIO9, and DMCOPY not used at the same time.</li> <li>When CMOS output type is selected</li> <li>See Fig. 9.</li> </ul>	tSCKH(2) + 2tCYC	tSCKH(2) + (10/3)tCYC							
tSCKHA(2b)	<ul style="list-style-type: none"> <li>Continuous data transfer mode</li> <li>USB used at the same time.</li> <li>AIF, SIO4, SIO9, and DMCOPY not used at the same time.</li> <li>When CMOS output type is selected.</li> <li>See Fig.9.</li> </ul>	tSCKH(2) + 2tCYC	tSCKH(2) + (19/3)tCYC	tCYC						
tSCKHA(2c)	<ul style="list-style-type: none"> <li>Continuous data transfer mode</li> <li>USB, AIF, SIO4, SIO9, and DMCOPY used at the same time</li> <li>When CMOS output type is selected</li> <li>See Fig.9.</li> </ul>	tSCKH(2) + 2tCYC	tSCKH(2) + (25/3)tCYC	tCYC						

Note 4-1-1: These specifications are theoretical values. Margins must be allowed according to the actual operating conditions.

Note 4-1-2: In an application where the serial clock input is to be used in the continuous data transfer mode, the time from SIORUN being set when serial clock is high to the falling edge of the first serial clock must be longer than tSCKHA.

Continued on next page.



# LC87F1JJ4B

Continued from preceding page.

Parameter		Symbol	Pin/ Remarks	Conditions	V <sub>DD</sub> [V]	Specification			
						min	typ	max	unit
Serial input	Data setup time	tsDI(1)	SB0(P11), SI0(P11)	<ul style="list-style-type: none"> <li>• Must be specified with respect to rising edge of SIOCLK.</li> <li>• See Fig. 9.</li> </ul>	2.7 to 5.5	0.03			
	Data hold time	thDI(1)				0.03			
Serial output	Output delay time	tdDO(1)	SO0(P10), SB0(P11)	<ul style="list-style-type: none"> <li>• Continuous data transfer mode</li> <li>• (Note 4-1-3)</li> </ul>	2.7 to 5.5			(1/3)t <sub>CY</sub> C +0.05	μs
		tdDO(2)				<ul style="list-style-type: none"> <li>• Synchronous 8-bit mode</li> <li>• (Note 4-1-3)</li> </ul>			
	Output clock	tdDO(3)		(Note 4-1-3)				(1/3)t <sub>CY</sub> C +0.05	

Note 4-1-3: Must be specified with respect to falling edge of SIOCLK.

Must be specified as the time to the beginning of output state change in open drain output mode. See Fig. 9.

## 2. SIO1 Serial I/O Characteristics (Note 4-2-1)

Parameter		Symbol	Pin/ Remarks	Conditions	V <sub>DD</sub> [V]	Specification				
						min	typ	max	unit	
Serial clock	Input clock	Frequency	SCK1(P15)	See Fig. 9.	2.7 to 5.5	2			t <sub>CYC</sub>	
		Low level pulse width				tSCKL(3)	1			
		High level pulse width				tSCKH(3)	1			
	Output clock	Frequency	SCK1(P15)	<ul style="list-style-type: none"> <li>• When CMOS output type is selected</li> <li>• See Fig. 9.</li> </ul>	2.7 to 5.5	2			t <sub>SCK</sub>	
		Low level pulse width				tSCKL(4)	1/2			
		High level pulse width				tSCKH(4)	1/2			
Serial input	Data setup time	tsDI(2)	SB1(P14), SI1(P14)	<ul style="list-style-type: none"> <li>• Must be specified with respect to rising edge of SIOCLK.</li> <li>• See Fig. 9.</li> </ul>	2.7 to 5.5	0.03				
	Data hold time	thDI(2)				0.03				
Serial output	Output delay time	tdDO(4)	SO1(P13), SB1(P14)	<ul style="list-style-type: none"> <li>• Must be specified with respect to falling edge of SIOCLK.</li> <li>• Must be specified as the time to the beginning of output state change in open drain output mode.</li> <li>• See Fig. 9.</li> </ul>	2.7 to 5.5			(1/3)t <sub>CYC</sub> +0.05	μs	

Note 4-2-1: These specifications are theoretical values. Margins must be allowed according to the actual operating conditions.

# LC87F1JJ4B

## 3. SIO4 Serial I/O Characteristics (Note 4-3-1)

	Parameter	Symbol	Pin/ Remarks	Conditions	V <sub>DD</sub> [V]	Specification				
						min	typ	max	unit	
Serial clock	Input clock	Frequency	tSCK(5)	SCK4(P24)	See Fig. 9.	2.7 to 5.5	2			tCYC
		Low level pulse width	tSCKL(5)				1			
		High level pulse width	tSCKH(5)				1			
			tSCKHA(5a)	<ul style="list-style-type: none"> <li>• USB, SIO0 continuous transfer mode, AIF, SIO9, and DMCOPY not used at the same time.</li> <li>• See Fig. 9.</li> <li>• (Note 4-3-2)</li> </ul>			4			
			tSCKHA(5b)	<ul style="list-style-type: none"> <li>• USB used at the same time</li> <li>• SIO0 continuous transfer mode, AIF, SIO9, and DMCOPY not used at the same time.</li> <li>• See Fig. 9.</li> <li>• (Note 4-3-2)</li> </ul>			7			
		tSCKHA(5c)	<ul style="list-style-type: none"> <li>• USB, SIO0 continuous transfer mode, SIO9, and DMCOPY used at the same time.</li> <li>• AIF not used at the same time.</li> <li>• See Fig. 9.</li> <li>• (Note 4-3-2)</li> </ul>	12						
	Output clock	Frequency	tSCK(6)	SCK4(P24)	<ul style="list-style-type: none"> <li>• When CMOS output type is selected.</li> <li>• See Fig. 9.</li> </ul>	2.7 to 5.5	4/3			tSCK
		Low level pulse width	tSCKL(6)				1/2			
		High level pulse width (Note 4-3-3)	tSCKH(6)				1/2			
			tSCKHA(6a)	<ul style="list-style-type: none"> <li>• USB, SIO0 continuous transfer mode, AIF, SIO9, and DMCOPY not used at the same time.</li> <li>• When CMOS output type is selected.</li> <li>• See Fig. 9.</li> </ul>	tSCKH(6) + (5/3)tCYC			tSCKH(6) + (10/3)tCYC		
			tSCKHA(6b)	<ul style="list-style-type: none"> <li>• USB used at the same time.</li> <li>• SIO0 continuous transfer mode, AIF, SIO9, and DMCOPY not used at the same time.</li> <li>• When CMOS output type is selected.</li> <li>• See Fig. 9.</li> </ul>	tSCKH(6) + (5/3)tCYC			tSCKH(6) + (19/3)tCYC	tCYC	
		tSCKHA(6c)	<ul style="list-style-type: none"> <li>• USB, SIO0 continuous transfer mode, SIO9, and DMCOPY used at the same time.</li> <li>• AIF not used at the same time.</li> <li>• When CMOS output type is selected.</li> <li>• See Fig. 9.</li> </ul>	tSCKH(6) + (5/3)tCYC			tSCKH(6) + (34/3)tCYC			

Note 4-3-1: These specifications are theoretical values. Margins must be allowed according to the actual operating conditions.

Note 4-3-2: In an application where the serial clock input is to be used in the continuous data transfer mode, the period from the time SI4RUN is set with the serial clock set high to the falling edge of the first serial clock must be longer than tSCKHA.

Note 4-3-3: When using the serial clock output, make sure that the load at the SCK4 (P24) pin meets the following conditions:

Clock rise time tSCKR < 0.037μs (see Figure 12.) at Ta=+25°C, V<sub>DD</sub>=3.3V

Continued on next page.

# LC87F1JJ4B

Continued from preceding page.

Parameter	Symbol	Pin/ Remarks	Conditions	Specification					
				V <sub>DD</sub> [V]	min	typ	max	unit	
Serial input	Data setup time	t <sub>sDI</sub> (3)	SO4(P22), SI4(P23)	• Must be specified with respect to rising edge of SIOCLK. • See Fig. 9	2.7 to 5.5	0.03			μs
	Data hold time	t <sub>hDI</sub> (3)				0.03			
Serial output	Output delay time	t <sub>dDO</sub> (5)	SO4(P22), SI4(P23)	• Must be specified with respect to falling edge of SIOCLK. • Must be specified as the time to the beginning of output state change in open drain output mode. • See Fig. 9.	2.7 to 5.5			(1/3)t <sub>CYC</sub> +0.05	μs

## 4. SIO9 Serial I/O Characteristics (Note 4-4-1)

Parameter	Symbol	Pin/ Remarks	Conditions	Specification					
				V <sub>DD</sub> [V]	min	typ	max	unit	
Serial clock input clock	Frequency	t <sub>SCK</sub> (7)	SCK9(P27)	See Fig. 9.	2.7 to 5.5	2			t <sub>CYC</sub>
	Low level pulse width	t <sub>SCKL</sub> (7)				1			
	High level pulse width	t <sub>SCKH</sub> (7)				1			
		t <sub>SCKHA</sub> (7a)				4			
	t <sub>SCKHA</sub> (7b)	7							
t <sub>SCKHA</sub> (7c)	15								

Note 4-4-1: These specifications are theoretical values. Margins must be allowed according to the actual operating conditions.

Note 4-4-2: In an application where the serial clock input is to be used in the continuous data transfer mode, the period from the time SI9RUN is set with the serial clock set high to the falling edge of the first serial clock must be longer than t<sub>SCKHA</sub>.

Continued on next page.

# LC87F1JJ4B

Continued from preceding page.

Parameter		Symbol	Pin/ Remarks	Conditions	V <sub>DD</sub> [V]	Specification			
						min	typ	max	unit
Serial clock	Output clock	Frequency	tSCK(8)	SCK9(P27)	2.7 to 5.5	4/3			tCYC
		Low level pulse width	tSCKL(8)						
		High level pulse width (Note 4-4-3)	tSCKH(8)	1/2		tCYC			
			tSCKHA(8a)	tSCKH(8) + (5/3)tCYC			tSCKH(8) + (10/3)tCYC		
		tSCKHA(8b)	<ul style="list-style-type: none"> <li>• USB, SIO0 continuous transfer mode, AIF, SIO4, and DMCOPY not used at the same time.</li> <li>• When CMOS output type is selected.</li> <li>• See Fig. 9.</li> </ul>	tSCKH(8) + (5/3)tCYC	tSCKH(8) + (19/3)tCYC	tCYC			
		tSCKHA(8c)	<ul style="list-style-type: none"> <li>• USB, SIO0 continuous transfer mode, SIO4, and DMCOPY used at the same time.</li> <li>• AIF not used at the same time.</li> <li>• When CMOS output type is selected.</li> <li>• See Fig. 9.</li> </ul>	tSCKH(8) + (5/3)tCYC	tSCKH(8) + (43/3)tCYC	tCYC			
Serial input	Data setup time	tsDI(4)	SO9(P25), SI9(P26)	<ul style="list-style-type: none"> <li>• Must be specified with respect to rising edge of SIOCLK.</li> <li>• See Fig. 9.</li> </ul>	2.7 to 5.5	0.03			μs
	Data hold time	thDI(4)							
Serial output	Output delay time	tdDO(6)	SO9(P25), SI9(P26)	<ul style="list-style-type: none"> <li>• Must be specified with respect to falling edge of SIOCLK.</li> <li>• Must be specified as the time to the beginning of output state change in open drain output mode</li> <li>• See Fig. 9.</li> </ul>	2.7 to 5.5			(1/3)tCYC +0.05	μs

Note 4-4-3: When using the serial clock output, make sure that the load at the SCK9 (P27) pin meets the following conditions:

Clock rise time tSCKR < 0.037μs (see Figure 12.) at Ta=+25°C, V<sub>DD</sub>=3.3V

## LC87F1JJ4B

### Pulse Input Conditions at Ta = -40°C to +85°C, VSS1 = VSS2 = VSS3 = 0V

Parameter	Symbol	Pin/Remarks	Conditions	Specification				
				VDD[V]	min	typ	max	unit
High/low level pulse width	tPIH(1) tPIL(1)	INT0(P70), INT1(P71), INT2(P72), INT4(P20 to P23), INT5(P24 to P27), INT6(P20), INT7(P24)	<ul style="list-style-type: none"> <li>Interrupt source flag can be set.</li> <li>Event inputs for timer 0 or 1 are enabled.</li> </ul>	2.7 to 5.5	1			tCYC
	tPIH(2) tPIL(2)	INT3(P73) when noise filter time constant is 1/1	<ul style="list-style-type: none"> <li>Interrupt source flag can be set.</li> <li>Event inputs for timer 0 are enabled.</li> </ul>	2.7 to 5.5	2			
	tPIH(3) tPIL(3)	INT3(P73) when noise filter time constant is 1/32	<ul style="list-style-type: none"> <li>Interrupt source flag can be set.</li> <li>Event inputs for timer 0 are enabled.</li> </ul>	2.7 to 5.5	64			
	tPIH(4) tPIL(4)	INT3(P73) when noise filter time constant is 1/128	<ul style="list-style-type: none"> <li>Interrupt source flag can be set.</li> <li>Event inputs for timer 0 are enabled.</li> </ul>	2.7 to 5.5	256			
	tPIL(5)	RMIN(P73)	Recognized by the infrared remote control receiver circuit as a signal	2.7 to 5.5	4			RMCK (Note 5-1)
	tPIL(6)	RES	Resetting is enabled.	2.7 to 5.5	200			μs

Note 5-1: Represents the period of the reference clock (1 tCYC to 128 tCYC or the source frequency of the subclock) for the infrared remote control receiver circuit.

### AD Converter Characteristics at Ta = -40°C to +85°C, VSS1 = VSS2 = VSS3 = 0V

Parameter	Symbol	Pin/Remarks	Conditions	Specification				
				VDD[V]	min	typ	max	unit
Resolution	N	AN0(P00) to AN7(P07), AN8(P70), AN9(P71), AN10(XT1), AN11(XT2)		3.0 to 5.5		8		bit
Absolute accuracy	ET		(Note 6-1)	3.0 to 5.5			±1.5	LSB
Conversion time	TCAD		AD conversion time=32×tCYC (when ADCR2=0) (Note 6-2)	4.5 to 5.5	15.68 (tCYC= 0.490μs)		97.92 (tCYC= 3.06μs)	μs
				3.0 to 5.5	23.52 (tCYC= 0.735μs)		97.92 (tCYC= 3.06μs)	
			AD conversion time=64×tCYC (when ADCR2=1) (Note 6-2)	4.5 to 5.5	18.82 (tCYC= 0.294μs)		97.92 (tCYC= 1.53μs)	
				3.0 to 5.5	47.04 (tCYC= 0.735μs)		97.92 (tCYC= 1.53μs)	
Analog input voltage range	VAIN			3.0 to 5.5	VSS		VDD	V
Analog port input current	IAINH		VAIN=VDD	3.0 to 5.5			1	μA
	IAINL		VAIN=VSS	3.0 to 5.5	-1			

Note 6-1: The quantization error (±1/2LSB) is excluded from the absolute accuracy.

Note 6-2: The conversion time refers to the period from the time when an instruction for starting a conversion process is issued to the time the conversion results register(s) are loaded with a complete digital conversion value corresponding to the analog input value.

# LC87F1JJ4B

## Consumption Current Characteristics at Ta = -40°C to +85°C, VSS1 = VSS2 = VSS3 = 0V

Parameter	Symbol	Pin/ Remarks	Conditions	Specification				
				VDD[V]	min	typ	max	unit
Normal mode consumption current (Note 7-1)	IDDOP(1)	VDD1 =VDD2 =VDD3	<ul style="list-style-type: none"> <li>FmCF=12MHz ceramic oscillation mode</li> <li>FsX'tal=32.768kHz crystal oscillation mode</li> <li>System clock set to 12MHz side</li> <li>Internal PLL oscillation stopped</li> <li>Internal RC oscillation stopped</li> <li>USB circuit stopped</li> <li>1/1 frequency division ratio</li> </ul>	4.5 to 5.5		11	27	mA
	IDDOP(2)		<ul style="list-style-type: none"> <li>Internal PLL oscillation stopped</li> <li>Internal RC oscillation stopped</li> <li>USB circuit stopped</li> <li>1/1 frequency division ratio</li> </ul>	3.0 to 3.6		6.2	16	
	IDDOP(3)		<ul style="list-style-type: none"> <li>FmCF=12MHz ceramic oscillation mode</li> <li>FsX'tal=32.768kHz crystal oscillation mode</li> <li>System clock set to 12MHz side</li> <li>Internal PLL oscillation mode active</li> <li>Internal RC oscillation stopped</li> <li>USB circuit active</li> <li>1/1 frequency division ratio</li> </ul>	4.5 to 5.5		16	37	
	IDDOP(4)		<ul style="list-style-type: none"> <li>Internal PLL oscillation mode active</li> <li>Internal RC oscillation stopped</li> <li>USB circuit active</li> <li>1/1 frequency division ratio</li> </ul>	3.0 to 3.6		8.0	21	
	IDDOP(5)		<ul style="list-style-type: none"> <li>FmCF=12MHz ceramic oscillation mode</li> <li>FsX'tal=32.768kHz crystal oscillation mode</li> <li>System clock set to 6MHz side</li> <li>Internal RC oscillation stopped</li> <li>1/2 frequency division ratio</li> </ul>	4.5 to 5.5		7.2	17	
	IDDOP(6)		<ul style="list-style-type: none"> <li>System clock set to 6MHz side</li> <li>Internal RC oscillation stopped</li> <li>1/2 frequency division ratio</li> </ul>	3.0 to 3.6		4.4	11	
	IDDOP(7)		<ul style="list-style-type: none"> <li>Internal RC oscillation stopped</li> <li>1/2 frequency division ratio</li> </ul>	2.7 to 3.0		3.6	8.2	
	IDDOP(8)		<ul style="list-style-type: none"> <li>FmCF=0Hz (oscillation stopped)</li> <li>FsX'tal=32.768kHz crystal oscillation mode</li> <li>System clock set to internal RC oscillation</li> <li>1/2 frequency division ratio</li> </ul>	4.5 to 5.5		0.77	3.7	
	IDDOP(9)		<ul style="list-style-type: none"> <li>FsX'tal=32.768kHz crystal oscillation mode</li> <li>System clock set to internal RC oscillation</li> <li>1/2 frequency division ratio</li> </ul>	3.0 to 3.6		0.43	2.0	
	IDDOP(10)		<ul style="list-style-type: none"> <li>System clock set to internal RC oscillation</li> <li>1/2 frequency division ratio</li> </ul>	2.7 to 3.0		0.36	1.6	
	IDDOP(11)		<ul style="list-style-type: none"> <li>FmCF=0Hz (oscillation stopped)</li> <li>FsX'tal=32.768kHz crystal oscillation mode</li> <li>System clock set to crystal oscillation side (32.768kHz)</li> <li>Internal RC oscillation stopped</li> <li>1/2 frequency division ratio</li> </ul>	4.5 to 5.5		47	184	
	IDDOP(12)		<ul style="list-style-type: none"> <li>System clock set to crystal oscillation side (32.768kHz)</li> <li>Internal RC oscillation stopped</li> <li>1/2 frequency division ratio</li> </ul>	3.0 to 3.6		19	65	
	IDDOP(13)		<ul style="list-style-type: none"> <li>Internal RC oscillation stopped</li> <li>1/2 frequency division ratio</li> </ul>	2.7 to 3.0		15	51	
HALT mode consumption current (Note7-1)	IDDHALT(1)		<ul style="list-style-type: none"> <li>HALT mode</li> <li>FmCF=12MHz ceramic oscillation mode</li> <li>FsX'tal=32.768kHz crystal oscillation mode</li> <li>System clock set to 12MHz side</li> <li>Internal PLL oscillation stopped</li> <li>Internal RC oscillation stopped</li> <li>USB circuit stopped</li> <li>1/1 frequency division ratio</li> </ul>	4.5 to 5.5		4.9	12	mA
	IDDHALT(2)		<ul style="list-style-type: none"> <li>Internal PLL oscillation stopped</li> <li>Internal RC oscillation stopped</li> <li>USB circuit stopped</li> <li>1/1 frequency division ratio</li> </ul>	3.0 to 3.6		2.7	6.4	
	IDDHALT(3)		<ul style="list-style-type: none"> <li>HALT mode</li> <li>FmCF=12MHz ceramic oscillation mode</li> <li>FsX'tal=32.768kHz crystal oscillation mode</li> <li>System clock set to 12MHz side</li> <li>Internal PLL oscillation mode active</li> <li>Internal RC oscillation stopped</li> <li>USB circuit active</li> <li>1/1 frequency division ratio</li> </ul>	4.5 to 5.5		9.5	23	
	IDDHALT(4)		<ul style="list-style-type: none"> <li>Internal PLL oscillation mode active</li> <li>Internal RC oscillation stopped</li> <li>USB circuit active</li> <li>1/1 frequency division ratio</li> </ul>	3.0 to 3.6		4.7	12	
	IDDHALT(5)		<ul style="list-style-type: none"> <li>HALT mode</li> <li>FmCF=12MHz ceramic oscillation mode</li> <li>FsX'tal=32.768kHz crystal oscillation mode</li> <li>System clock set to 6MHz side</li> <li>Internal RC oscillation stopped</li> <li>1/2 frequency division ratio</li> </ul>	4.5 to 5.5		3.0	7.3	
	IDDHALT(6)		<ul style="list-style-type: none"> <li>System clock set to 6MHz side</li> <li>Internal RC oscillation stopped</li> <li>1/2 frequency division ratio</li> </ul>	3.0 to 3.6		1.6	3.8	
	IDDHALT(7)		<ul style="list-style-type: none"> <li>Internal RC oscillation stopped</li> <li>1/2 frequency division ratio</li> </ul>	2.7 to 3.0		1.3	2.9	
	IDDHALT(8)		<ul style="list-style-type: none"> <li>HALT mode</li> <li>FmCF=0Hz (oscillation stopped)</li> <li>FsX'tal=32.768kHz crystal oscillation mode</li> <li>System clock set to internal RC oscillation</li> <li>1/2 frequency division ratio</li> </ul>	4.5 to 5.5		0.41	2.0	
	IDDHALT(9)		<ul style="list-style-type: none"> <li>FsX'tal=32.768kHz crystal oscillation mode</li> <li>System clock set to internal RC oscillation</li> <li>1/2 frequency division ratio</li> </ul>	3.0 to 3.6		0.20	0.95	
	IDDHALT(10)		<ul style="list-style-type: none"> <li>System clock set to internal RC oscillation</li> <li>1/2 frequency division ratio</li> </ul>	2.7 to 3.0		0.17	0.70	

Note 7-1: The consumption current value includes none of the currents that flow into the output Tr and internal pull-up resistors.

Continued on next page.

# LC87F1JJ4B

Continued from preceding page.

Parameter	Symbol	Pin/ Remarks	Conditions	Specification				
				V <sub>DD</sub> [V]	min	typ	max	unit
HALT mode consumption current (Note 7-1)	IDDHALT(11)	V <sub>DD1</sub> =V <sub>DD2</sub> =V <sub>DD3</sub>	<ul style="list-style-type: none"> <li>• HALT mode</li> <li>• FmCF=0Hz (oscillation stopped)</li> <li>• FsX'tal=32.768kHz crystal oscillation mode (32.768kHz)</li> <li>• System clock set to crystal oscillation side</li> <li>• Internal RC oscillation stopped</li> <li>• 1/2 frequency division ratio</li> </ul>	4.5 to 5.5		31	132	μA
	IDDHALT(12)			3.0 to 3.6		9.1	53	
	IDDHALT(13)			2.7 to 3.0		6.3	42	
HOLD mode consumption current	IDDHOLD(1)	V <sub>DD1</sub>	<ul style="list-style-type: none"> <li>• HOLD mode</li> <li>• CF1=V<sub>DD</sub> or open (External clock mode)</li> </ul>	4.5 to 5.5		0.24	72	
	IDDHOLD(2)			3.0 to 3.6		0.12	38	
	IDDHOLD(3)			2.7 to 3.0		0.11	33	
Timer HOLD mode consumption current	IDDHOLD(4)	V <sub>DD1</sub>	<ul style="list-style-type: none"> <li>• Timer HOLD mode</li> <li>• CF1=V<sub>DD</sub> or open (External clock mode)</li> <li>• FsX'tal=32.768kHz crystal oscillation mode</li> </ul>	4.5 to 5.5		26	115	
	IDDHOLD(5)			3.0 to 3.6		6.1	50	
	IDDHOLD(6)			2.7 to 3.0		3.8	40	

Note 7-1: The consumption current value includes none of the currents that flow into the output Tr and internal pull-up resistors.

## USB Characteristics and Timing at Ta = -40°C to +85°C, V<sub>SS1</sub> = V<sub>SS2</sub> = V<sub>SS3</sub> = 0V

Parameter	Symbol	Conditions	Specification			
			min	typ	max	unit
High level output	V <sub>OH</sub> (USB)	• 15kΩ±5% to GND	2.8		3.6	V
Low level output	V <sub>OL</sub> (USB)	• 1.5kΩ±5% to 3.6V	0.0		0.3	V
Output signal crossover voltage	V <sub>CRS</sub>		1.3		2.0	V
Differential input sensitivity	V <sub>DI</sub>	•  (UHD+)-(UHD-)	0.2			V
Differential input common mode range	V <sub>CM</sub>		0.8		2.5	V
High level input	V <sub>IH</sub> (USB)		2.0			V
Low level input	V <sub>IL</sub> (USB)				0.8	V
USB data rise time	t <sub>R</sub>	• R <sub>S</sub> =33Ω, C <sub>L</sub> =50pF	4		20	ns
USB data fall time	t <sub>F</sub>	• R <sub>S</sub> =33Ω, C <sub>L</sub> =50pF	4		20	ns

## F-ROM Programming Characteristics at Ta = +10°C to +55°C, V<sub>SS1</sub> = V<sub>SS2</sub> = V<sub>SS3</sub> = 0V

Parameter	Symbol	Pin/ Remarks	Conditions	Specification				
				V <sub>DD</sub> [V]	min	typ	max	unit
Onboard programming current	IDDFW(1)	V <sub>DD1</sub>	• Excluding power dissipation in the microcontroller block	3.0 to 5.5		5	10	mA
Programming time	t <sub>FW</sub> (1)		• Erase operation	3.0 to 5.5		20	30	ms
	t <sub>FW</sub> (2)		• Write operation			40	60	μs

## Main System Clock Oscillation

The constant values of the oscillator and oscillation circuit for the main and system clocks must be determined after exercising extensive oscillation evaluation tests. For an application in which the USB host function is to be used, use an oscillator having the accuracy and precision that satisfy the USB specifications.

The oscillation stabilization time refers to the time interval that is required for the oscillation to get stabilized in the following cases (see Figure 4):

- Till the oscillation gets stabilized after V<sub>DD</sub> goes above the operating voltage lower limit.
- Till the oscillation gets stabilized after the instruction for starting the main clock oscillation circuit is executed.
- Till the oscillation gets stabilized after the HOLD mode is released.
- Till the oscillation gets stabilized after the X'tal HOLD mode is released with CFSTOP (OCR register, bit 0) set to 0.

### Subsystem Clock Oscillation

Table 1 shows the characteristics of a sample subsystem clock oscillation circuit that are measured using a SANYO-designated oscillation characteristics evaluation board and external components with circuit constant values with which the oscillator vendor confirmed normal and stable oscillation.

Table 1 Characteristics of a Sample subsystem Clock Oscillator Circuit with a Crystal Oscillator

Nominal Frequency	Vendor Name	Oscillator Name	Circuit Constant				Operating Voltage Range [V]	Oscillation Stabilization Time		Remarks
			C3 [pF]	C4 [pF]	Rf [ $\Omega$ ]	Rd2 [ $\Omega$ ]		typ [s]	max [s]	
32.768kHz	EPSON TOYOCOM	MC-306	18	18	OPEN	560k	2.7 to 5.0	1.1	3.0	Applicable CL value=12.5pF SMD type

The oscillation stabilization time refers to the time interval that is required for the oscillation to get stabilized in the following cases (see Figure 4):

- Till the oscillation gets stabilized after the instruction for starting the subclock oscillation circuit is executed.
- Till the oscillation gets stabilized after the HOLD mode is released with EXTOSC (OCR register, bit 6) set to 1

Note: The components that are involved in oscillation should be placed as close to the IC and to one another as possible because they are vulnerable to the influences of the circuit pattern.

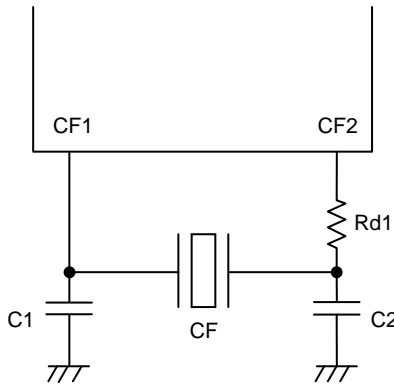

Figure 1 CF Oscillator Circuit

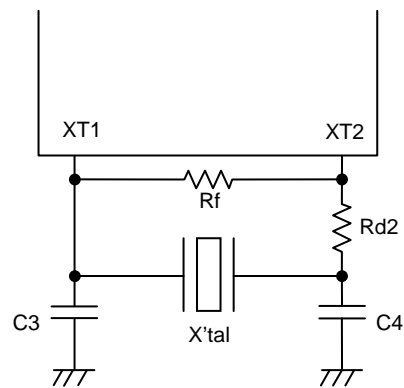

Figure 2 Crystal Oscillator Circuit

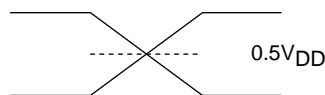
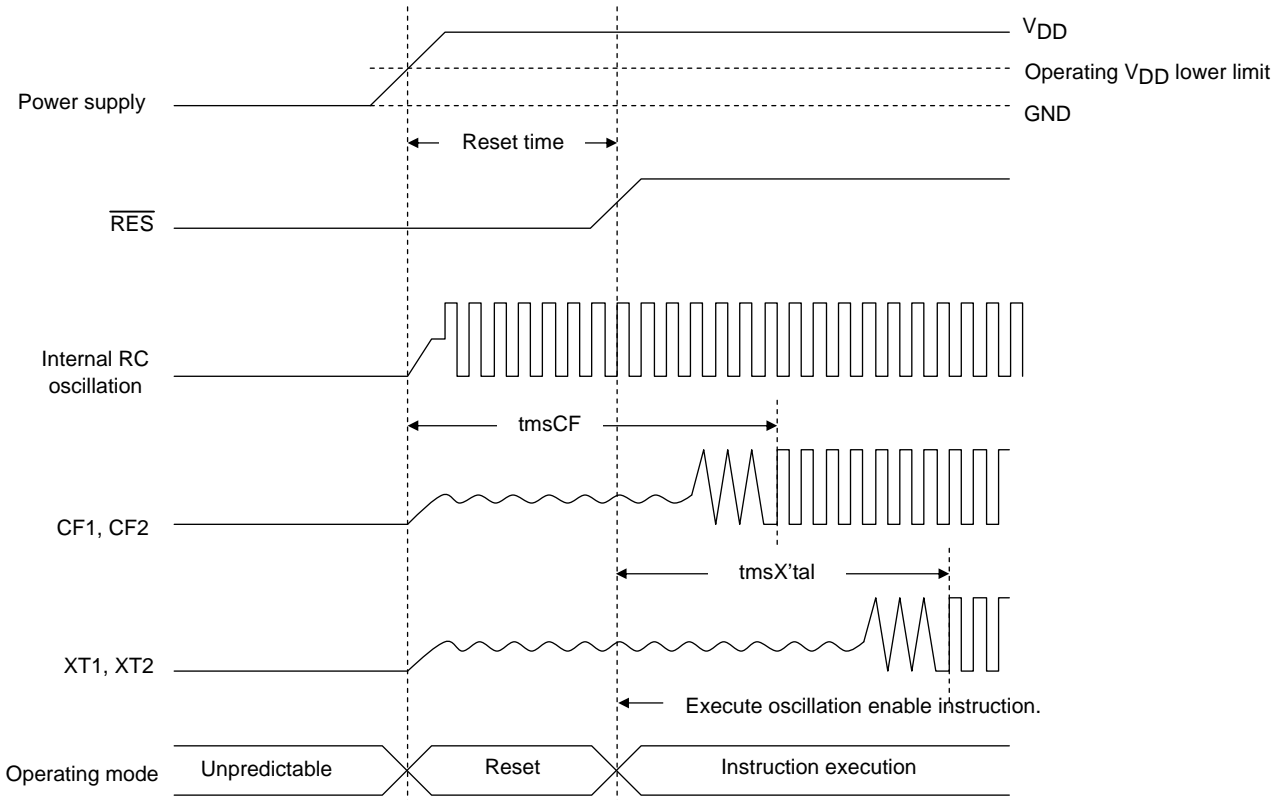

Figure 3 AC Timing Measurement Point



# LC87F1JJ4B



## Reset Time and Oscillation Stabilization Time

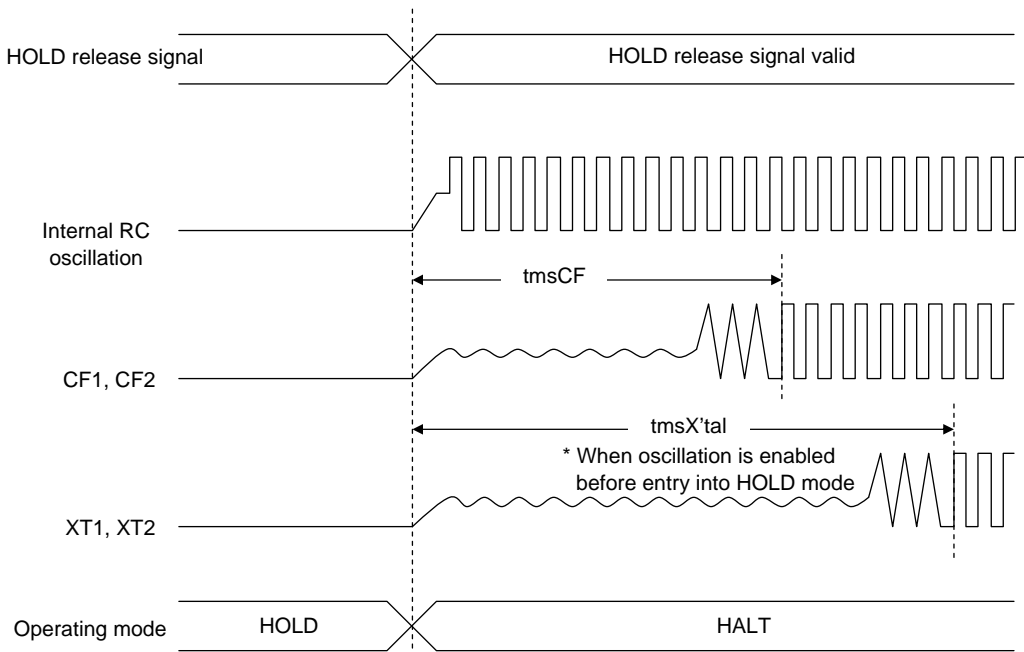

## HOLD Release Signal and Oscillation Stabilization Time

Figure 4 Oscillation Stabilization Time

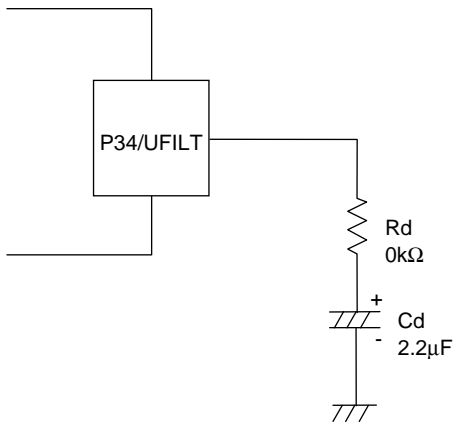

When using the internal PLL circuit to generate the 48MHz clock for USB, it is necessary to connect a filter circuit to the P34/UFILT pin such as that shown in the left figure.

Figure 5 External Filter Circuit for the Internal USB-dedicated PLL Circuit

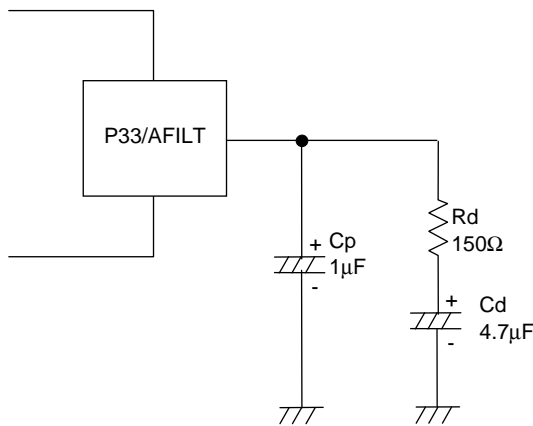

To generate the master clock for the audio interface using the internal PLL circuit, it is necessary to connect a filter circuit to the P33/AFILT pin that is shown in the left figure.

Figure 6 External Filter Circuit for Audio Interface (Used with Internal PLL Circuit)

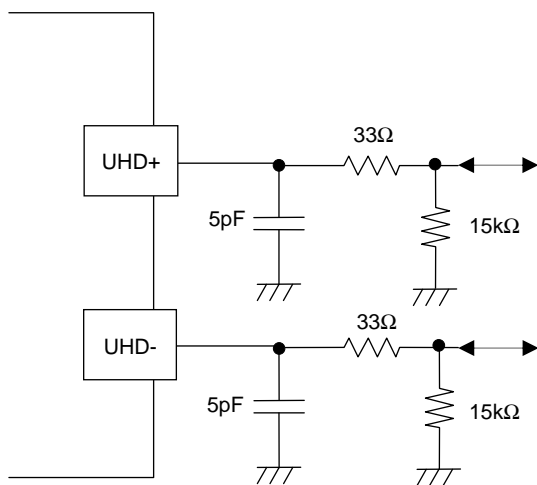

It is necessary to adjust the Circuit Constant of the USB Port Peripheral Circuit for each mounting board.

Figure 7 USB Port Peripheral Circuit

# LC87F1JJ4B

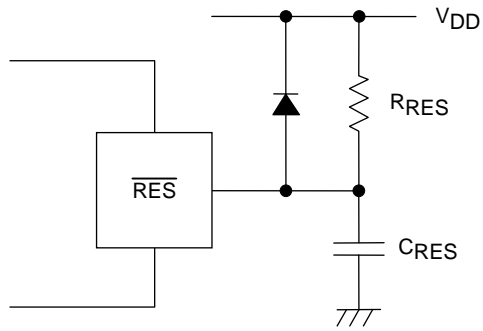

Note:  
Determine the value of  $C_{RES}$  and  $R_{RES}$  so that the reset signal is present for a period of  $200\mu s$  after the supply voltage goes beyond the lower limit of the IC's operating voltage.

Figure 8 Reset Circuit

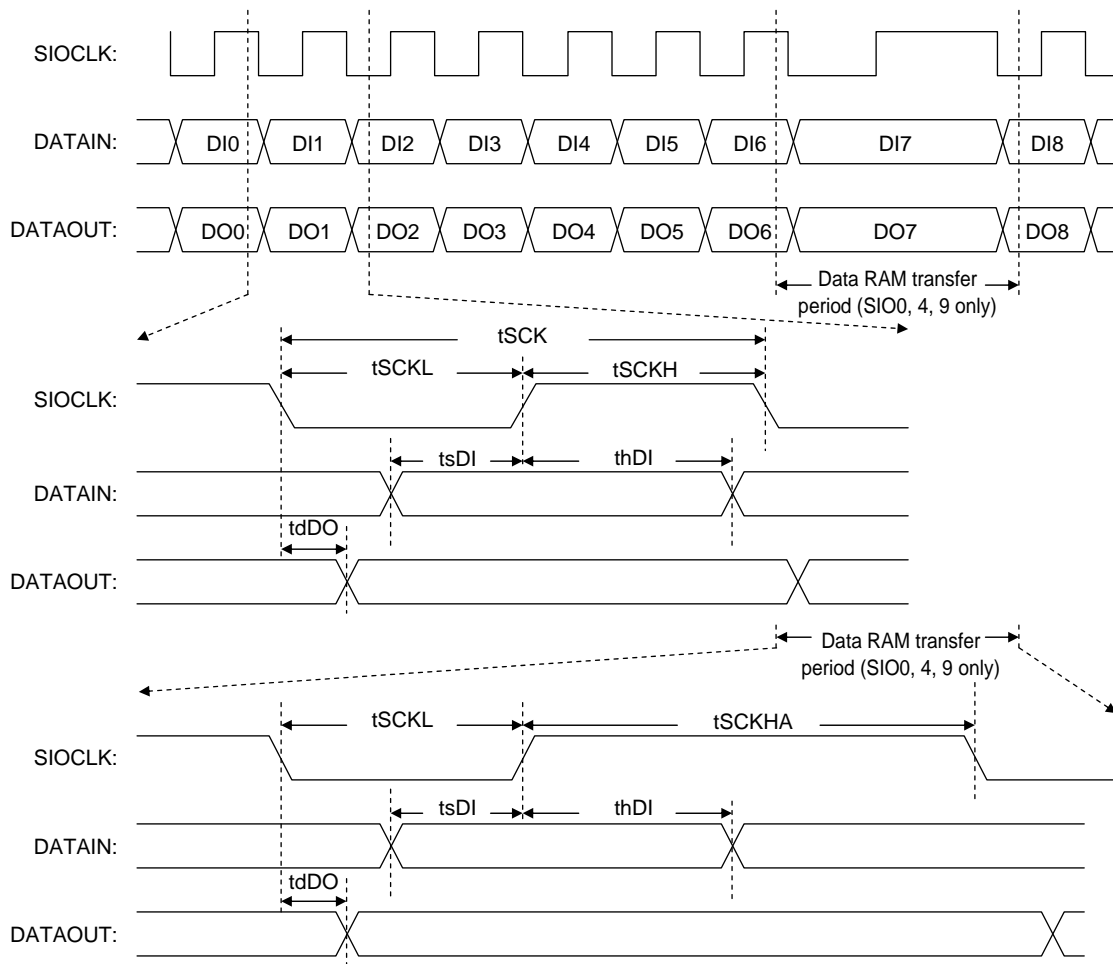

Figure 9 Serial I/O Waveform

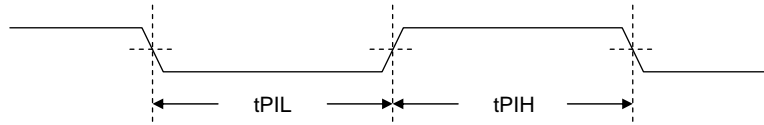

Figure 10 Pulse Input Timing Signal Waveform

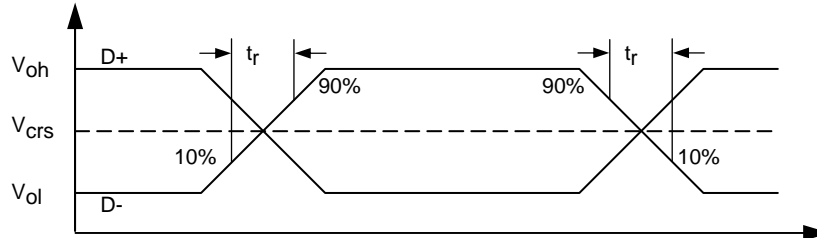
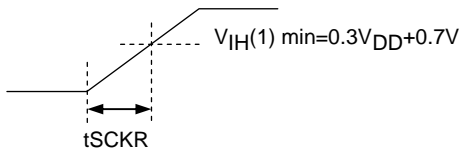

Figure 11 USB Data Signal Timing and Voltage Level



tSCKR:  
Defined as the time period from the time the state of the output starts changing till the time it reaches the value of  $V_{IH}(1)$ .

Figure 12 Serial Clock Output Timing Signal Waveform

- SANYO Semiconductor Co.,Ltd. assumes no responsibility for equipment failures that result from using products at values that exceed, even momentarily, rated values (such as maximum ratings, operating condition ranges, or other parameters) listed in products specifications of any and all SANYO Semiconductor Co.,Ltd. products described or contained herein.
- SANYO Semiconductor Co.,Ltd. strives to supply high-quality high-reliability products, however, any and all semiconductor products fail or malfunction with some probability. It is possible that these probabilistic failures or malfunction could give rise to accidents or events that could endanger human lives, trouble that could give rise to smoke or fire, or accidents that could cause damage to other property. When designing equipment, adopt safety measures so that these kinds of accidents or events cannot occur. Such measures include but are not limited to protective circuits and error prevention circuits for safe design, redundant design, and structural design.
- In the event that any or all SANYO Semiconductor Co.,Ltd. products described or contained herein are controlled under any of applicable local export control laws and regulations, such products may require the export license from the authorities concerned in accordance with the above law.
- No part of this publication may be reproduced or transmitted in any form or by any means, electronic or mechanical, including photocopying and recording, or any information storage or retrieval system, or otherwise, without the prior written consent of SANYO Semiconductor Co.,Ltd.
- Any and all information described or contained herein are subject to change without notice due to product/technology improvement, etc. When designing equipment, refer to the "Delivery Specification" for the SANYO Semiconductor Co.,Ltd. product that you intend to use.
- Information (including circuit diagrams and circuit parameters) herein is for example only; it is not guaranteed for volume production.
- Upon using the technical information or products described herein, neither warranty nor license shall be granted with regard to intellectual property rights or any other rights of SANYO Semiconductor Co.,Ltd. or any third party. SANYO Semiconductor Co.,Ltd. shall not be liable for any claim or suits with regard to a third party's intellectual property rights which has resulted from the use of the technical information and products mentioned above.

This catalog provides information as of July, 2009. Specifications and information herein are subject to change without notice.