

isc Silicon NPN Power Transistors

D44T3/4

DESCRIPTION

- Collector-Emitter Sustaining Voltage-
: $V_{CEO(SUS)} = 300V$ (Min)
- High Switching Speed
- Low Saturation Voltage

APPLICATIONS

- Designed for general purpose amplifier and switching applications.

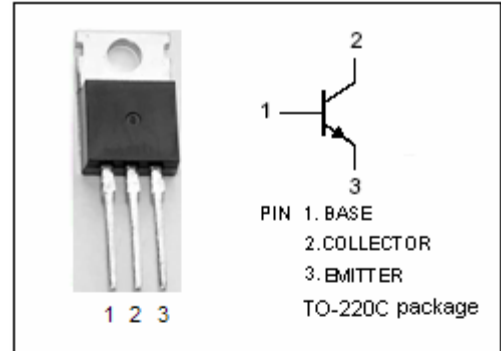

ABSOLUTE MAXIMUM RATINGS($T_a=25^{\circ}C$)

SYMBOL	PARAMETER	VALUE	UNIT
V_{CES}	Collector-Emitter Voltage $V_{BE}=0$	400	V
V_{CEO}	Collector-Emitter Voltage	300	V
V_{EBO}	Emitter-Base Voltage	5	V
I_C	Collector Current-Continuous	2	A
I_{CM}	Collector Current-Peak	4	A
I_B	Base Current-Continuous	0.5	A
P_C	Collector Power Dissipation @ $T_C=25^{\circ}C$	31.2	W
T_J	Junction Temperature	150	$^{\circ}C$
T_{stg}	Storage Temperature Range	-55~150	$^{\circ}C$

THERMAL CHARACTERISTICS

SYMBOL	PARAMETER	MAX	UNIT
$R_{th\ j-c}$	Thermal Resistance, Junction to Case	4	$^{\circ}C/W$

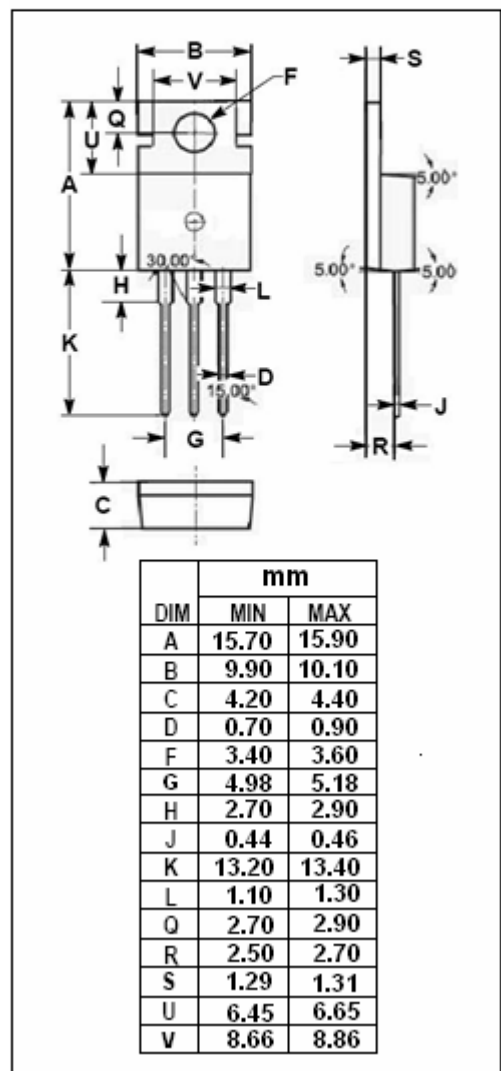

isc Silicon NPN Power Transistors

D44T3/4

ELECTRICAL CHARACTERISTICS

 $T_C=25^\circ\text{C}$ unless otherwise specified

SYMBOL	PARAMETER	CONDITIONS	MIN	TYP.	MAX	UNIT
$V_{CE(sat)}$	Collector-Emitter Saturation Voltage	$I_C=0.5\text{A}; I_B=50\text{mA}$			1.0	V
$V_{BE(sat)}$	Base-Emitter Saturation Voltage	$I_C=0.5\text{A}; I_B=50\text{mA}$			1.2	V
I_{CES}	Collector Cutoff Current	$V_{CE}=400\text{V}; V_{BE}=0$			10	μA
I_{EBO}	Emitter Cutoff Current	$V_{EB}=5\text{V}; I_C=0$			10	μA
h_{FE-1}	DC Current Gain	D44T3	$I_C=0.5\text{A}; V_{CE}=10\text{V}$	30		90
		D44T4		75		175
h_{FE-2}	DC Current Gain	D44T3	$I_C=50\text{mA}; V_{CE}=10\text{V}$	20		
		D44T4		40		
f_T	Current-Gain—Bandwidth Product	$I_C=0.1\text{A}; V_{CE}=10\text{V}; f_{test}=1\text{MHz}$		15		MHz
t_r	Rise Time	$I_C=0.5\text{A}; I_{B1}=-I_{B2}=50\text{mA}$			0.3	μs
t_{stg}	Storage Time				3.0	μs
t_f	Fall Time				0.7	μs