

Silicon NPN Power Transistors

2SD1892

DESCRIPTION

- With TO-220Fa package
- High DC current gain
- Low collector saturation voltage
- DARLINGTON
- Complement to type 2SB1252

APPLICATIONS

- Power amplification
- Optimum for 35W high-fidelity output

PINNING

PIN	DESCRIPTION
1	Base
2	Collector
3	Emitter

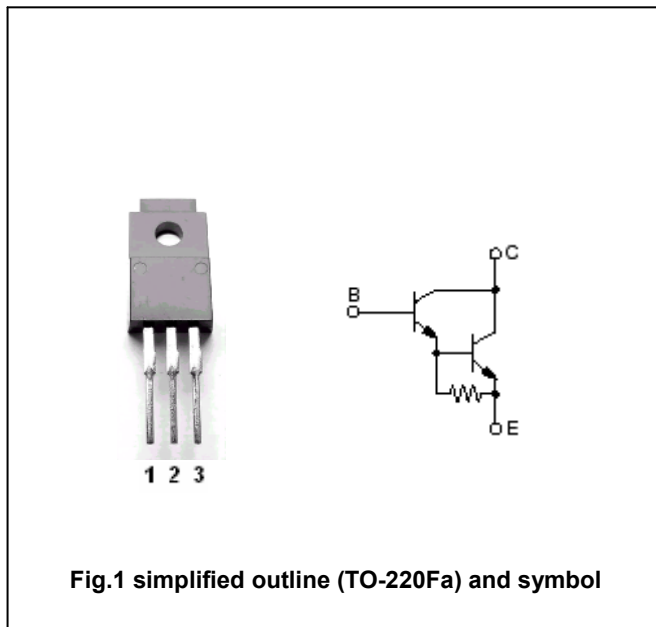

Absolute maximum ratings(Ta=25°C)

SYMBOL	PARAMETER	CONDITIONS	VALUE	UNIT
V _{CBO}	Collector-base voltage	Open emitter	120	V
V _{CEO}	Collector-emitter voltage	Open base	100	V
V _{EBO}	Emitter-base voltage	Open collector	5	V
I _C	Collector current		5	A
I _{CM}	Collector current-peak		8	A
P _C	Collector power dissipation	T _C =25°C	45	W
		T _a =25°C	2	
T _j	Junction temperature		150	°C
T _{stg}	Storage temperature		-55~150	°C

Silicon NPN Power Transistors

2SD1892

CHARACTERISTICS

T_j=25 °C unless otherwise specified

SYMBOL	PARAMETER	CONDITIONS	MIN	TYP.	MAX	UNIT
V _{(BR)CEO}	Collector-emitter breakdown voltage	I _C =30mA ; I _B =0	100			V
V _{CEsat}	Collector-emitter saturation voltage	I _C =4A ; I _B =4mA			2.5	V
V _{BEsat}	Base-emitter saturation voltage	I _C =4A ; I _B =4mA			3.0	V
I _{CBO}	Collector cut-off current	V _{CB} =120V ; I _E =0			100	μA
I _{CEO}	Collector cut-off current	V _{CE} =100V ; I _B =0			100	μA
I _{EBO}	Emitter cut-off current	V _{EB} =5V ; I _C =0			100	μA
h _{FE-1}	DC current gain	I _C =1A ; V _{CE} =5V	2000			
h _{FE-2}	DC current gain	I _C =4A ; V _{CE} =5V	5000		30000	
f _T	Transition frequency	I _C =0.5A ; V _{CE} =10V ; f=1MHz		20		MHz

Switching times

t _{on}	Turn-on time	I _C =4A ; V _{CC} =50V I _{B1} =-I _{B2} =4mA		2.5		μs
t _s	Storage time			3.5		μs
t _f	Fall time			1.0		μs

◆ h_{FE-2} Classifications

Q	P
5000-15000	8000-30000

Silicon NPN Power Transistors

2SD1892

PACKAGE OUTLINE

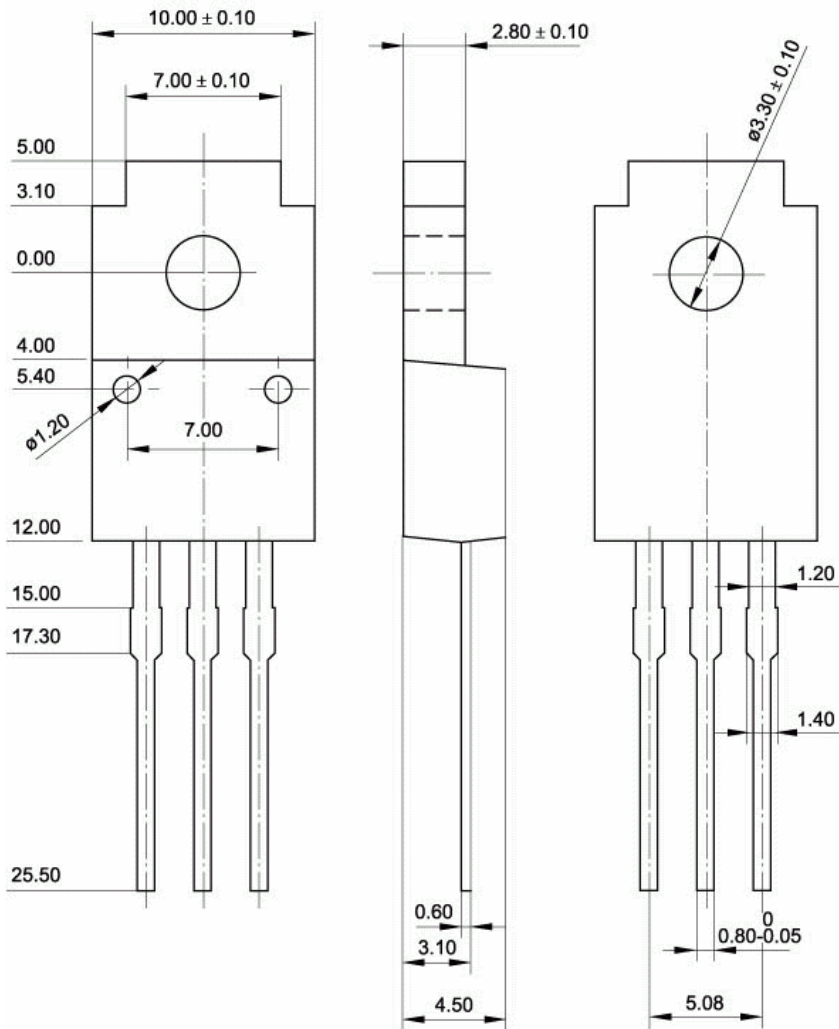

Fig.2 Outline dimensions (unindicated tolerance: ± 0.15 mm)