

**9-PIN CONNECTOR
WIRING DIAGRAM
(PHASESHIFTER)**

PIN#	OPERATION
2+	INCREASE PHASE
7-	
2-	DECREASE PHASE
7+	
1/6	MAX. POSITION INDICATOR
3/8	MIN. POSITION INDICATOR
5	WIPER (TRACKING POT)
4/9	TRACKING POT

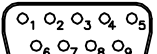

9-PIN D-SUB CONN. (M)

REVISIONS			
REV	DESCRIPTION	DATE	APPROVED
A	INITIAL RELEASE	01/04/01	
B	CHANGED PIN OUT TABLE	6/5/01	
C	DWG. NO. WAS: 6000, IS: 5025	6/17/02	
D	REVISED PINOUT, NOTES, TITLE BLOCK	9/24/02	
E	PIN-OUT TABLE UPDATED	8/24/05	

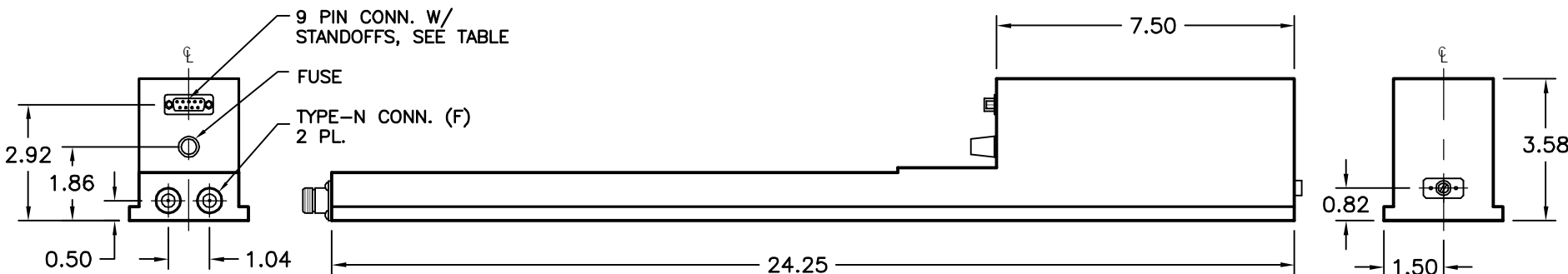
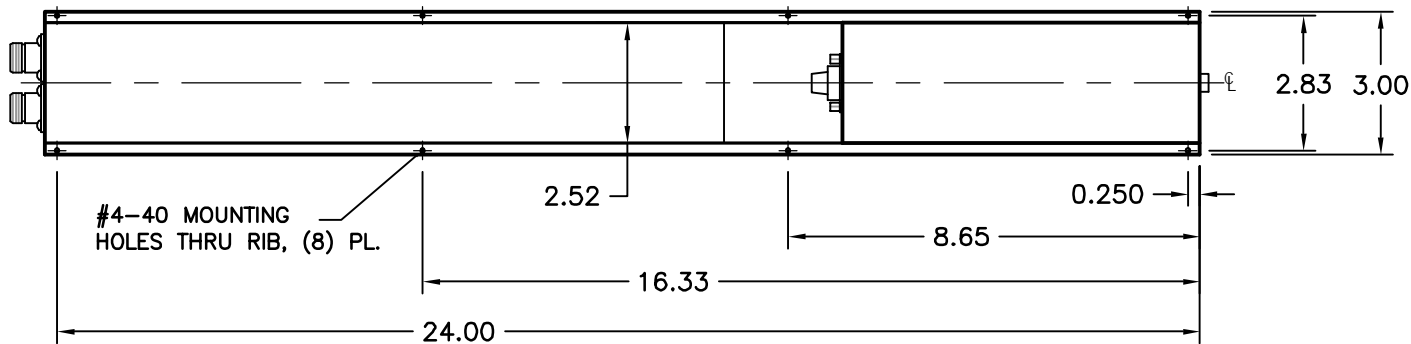

NOTES:

- 28 V dc MOTOR
- 10 K ohm FOLLOWER POT (OPTIONAL)
- 2 AMP FUSE

MATERIAL	6061 ALUM.	TREATMENT	-	DRAWN	M. ROTUNDA	DATE	9/24/02			
FINISH	ATM STD. GRAY	MOD NO.	P2102/3-28	CHECKED		DATE				
OUTLINE, 360° PHASESHIFTER, MOTORDRIVE				APPROVED		DATE				
				CAGE CODE: OR8N4		DO NOT SCALE DWG				
ADVANCED TECHNICAL MATERIALS, INC. 49 RIDER AVE., PATCHOGUE N.Y. 11772 TEL: (631) 289-0386 FAX: (631) 289-0358 http://www.atmmicrowave.com				UNLESS OTHERWISE NOTED DIMENSIONS ARE IN INCHES TOLERANCES ARE:		FRACTIONS ±1/64	DECIMALS ±.01	ANGLES ±1/2°	SHEET.	
PROPRIETARY NOTICE: THE INFORMATION IN THIS DRAWING IS PROPRIETARY AND SHALL NOT BE USED OR DISCLOSED WITHOUT THE PRIOR WRITTEN CONSENT OF ATM, INC.						SCALE	1 : 4	DWG. NO.	5025W	REV.
									E	