



LB1945D

Monolithic Digital IC
 PWM Current Control
 Stepping Motor Driver

Overview

The LB1945D is a PWM current control stepping motor driver that uses a bipolar drive technique. It is optimal for use with the carriage and paper feed stepping motors used in printers.

Functions and Features

- PWM current control (external clock)
- Digital load current selection function (supports 1-2, W1-2, and 2-phase excitation)
- Built-in high and low side diodes
- Simultaneous on state prevention function (through-current prevention)
- Built-in thermal shutdown circuit
- Noise canceling function

Specifications

Absolute Maximum Ratings at $T_a = 25^\circ\text{C}$

Parameter	Symbol	Conditions	Ratings	Unit
Motor supply voltage	V_{BB} max		30	V
Output peak current	I_O peak	$tW \leq 20\mu\text{s}$	1.0	A
Output continuous current	I_O max		0.8	A
Logic system supply voltage	V_{CC} max		6.0	V
Logic input voltage range	V_{IN}		-0.3 to V_{CC}	V
Emitter output voltage range	V_E		1.0	V
Allowable power dissipation	P_d max	Independent IC	2.8	W
Operating temperature	T_{opr}		-20 to +90	$^\circ\text{C}$
Storage temperature	T_{stg}		-55 to +150	$^\circ\text{C}$

■ Any and all SANYO Semiconductor Co.,Ltd. products described or contained herein are, with regard to "standard application", intended for the use as general electronics equipment (home appliances, AV equipment, communication device, office equipment, industrial equipment etc.). The products mentioned herein shall not be intended for use for any "special application" (medical equipment whose purpose is to sustain life, aerospace instrument, nuclear control device, burning appliances, transportation machine, traffic signal system, safety equipment etc.) that shall require extremely high level of reliability and can directly threaten human lives in case of failure or malfunction of the product or may cause harm to human bodies, nor shall they grant any guarantee thereof. If you should intend to use our products for applications outside the standard applications of our customer who is considering such use and/or outside the scope of our intended standard applications, please consult with us prior to the intended use. If there is no consultation or inquiry before the intended use, our customer shall be solely responsible for the use.

■ Specifications of any and all SANYO Semiconductor Co.,Ltd. products described or contained herein stipulate the performance, characteristics, and functions of the described products in the independent state, and are not guarantees of the performance, characteristics, and functions of the described products as mounted in the customer's products or equipment. To verify symptoms and states that cannot be evaluated in an independent device, the customer should always evaluate and test devices mounted in the customer's products or equipment.

LB1945D

Recommended Operating Range at Ta = 25°C

Parameter	Symbol	Conditions	Ratings	Unit
Motor supply voltage	V _{BB}		10 to 28	V
Logic system supply voltage	V _{CC}		4.75 to 5.25	V
Reference voltage	V _{REF}		1.5 to 5.0	V

Electrical Characteristics at Ta = 25°C, V_{BB} = 24V, V_{CC} = 5V, V_{REF} = 5V

Parameter	Symbol	Conditions	Ratings			Unit
			min	typ	max	
Output block						
Output stage supply current	I _{BB ON} I _{BB OFF}	I ₁ = 0.8V, I ₂ = 0.8V, ENABLE = 0.8V ENABLE = 3.2V	0.5	1.0	2.0 0.2	mA
Output saturation voltage 1	V _{O sat1}	I _O = +0.5A, sink side		0.3	0.5	V
Output saturation voltage 2	V _{O sat2}	I _O = +0.8A, sink side		0.5	0.7	V
Output saturation voltage 3	V _{O sat3}	I _O = -0.5A, source side		1.6	1.8	V
Output saturation voltage 4	V _{O sat4}	I _O = -0.8A, source side		1.8	2.0	V
Output leakage current	V _{O1(leak)} V _{O2(leak)}	V _O = V _{BB} , sink side V _O = 0V, source side	-50		50	μA
Output sustain voltage	VSUS	L = 3.9mH, I _O = 1.0A*	30			V
Logic block						
Logic supply current	I _{CC ON} I _{CC OFF}	I ₁ = 0.8V, I ₂ = 0.8V, ENABLE = 0.8V ENABLE = 3.2V	50 7	70.0 10.0	92 13	mA
Input voltage	V _{IH} V _{IL}		3.2		1.8	V
Input current	I _{IH} I _{IL}	V _{IH} = 3.2V V _{IL} = 0.8V	35 7	50 10	65 13	μA
Set current control threshold value	V _{REF} / V _{SEN}	I ₁ = 0.8V, I ₂ = 0.8V I ₁ = 3.2V, I ₂ = 0.8V I ₁ = 0.8V, I ₂ = 3.2V	9.5 13.5 25.5	10 15 30	10.5 16.5 34.5	
Reference current	I _{REF}	V _{REF} = 5.0V, I ₁ = 0.8V, I ₂ = 0.8V	17.5	25	32.5	μA
CR pin current	I _{CR}	CR = 1.0V	-1.0			μA
Thermal shutdown temperature	TS			170		°C
Thermal shutdown hysteresis	TSHY			40		°C

*: The design specification items are design guarantees and are not measured.

Package Dimensions

unit:mm (typ)

3147C

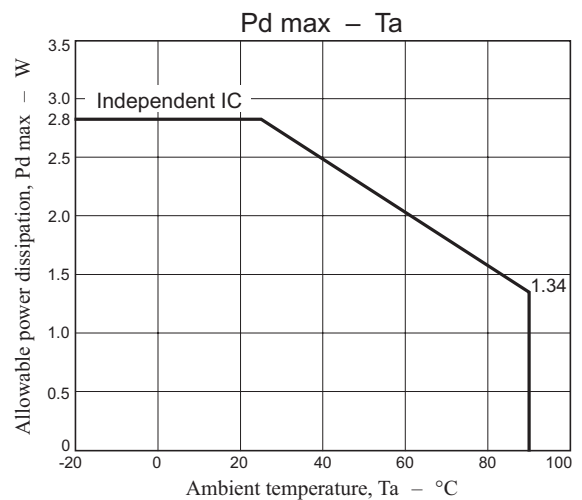
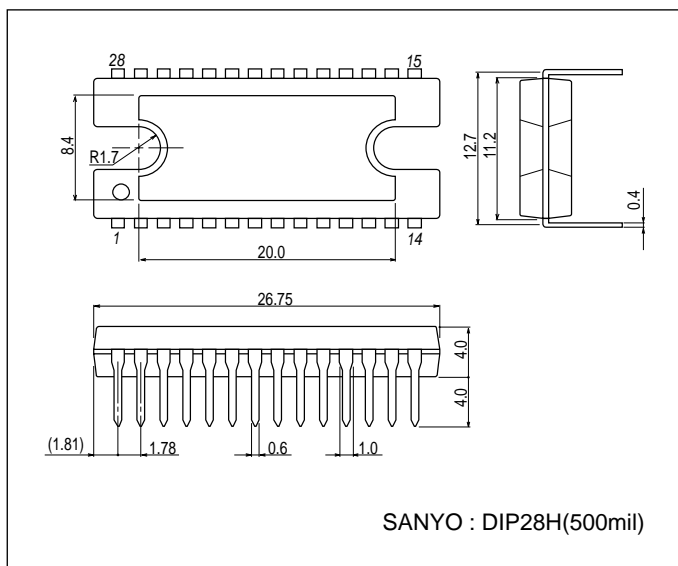

LB1945D

Pin Assignment

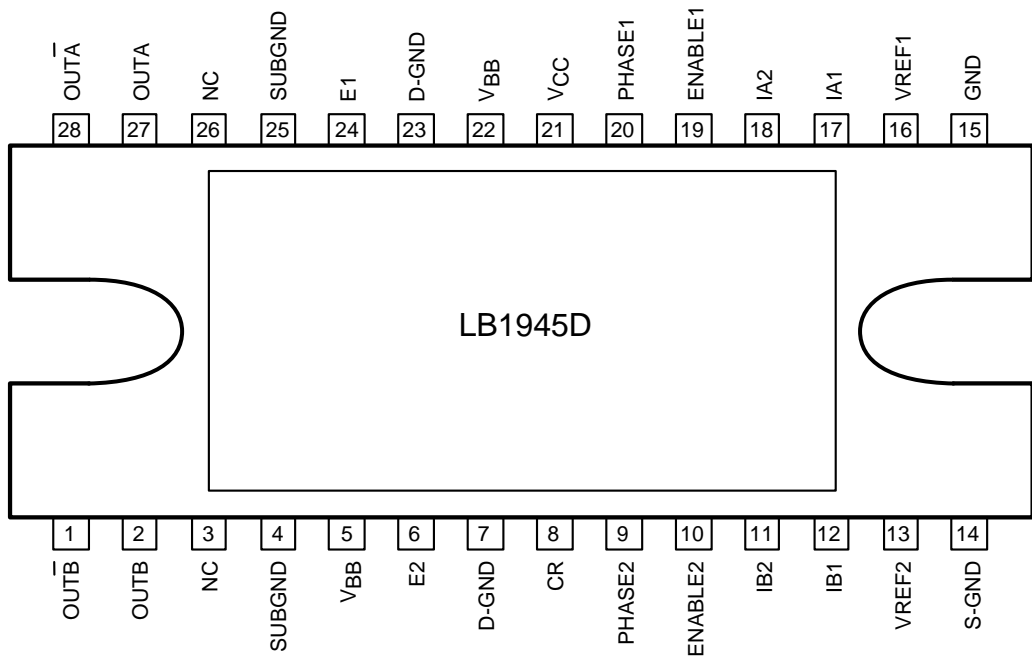

Pin Functions

Pin No.	Pin	Description
22	V _{BB1}	Output stage power supply voltage
5	V _{BB2}	High side diode cathode connection
24	E1	The set current is controlled by inserting resistors R _E between these pins and ground.
6	E2	
27	OUTA	Output pins
28	OUT \bar{A}	
2	OUTB	
1	OUT \bar{B}	
15	GND	Ground
14	S-GND	Sense ground
4, 25	SUBGND	IC sub-ground
23	D-GND	Low side built-in diode ground (anode side)
7		
8	CR	Chopping is performed at the period of a triangle wave set by the RC circuit connected to this pin. The triangle wave off time is the noise cancellation time.
16	VREF1	Output current settings. (The output current is determined by providing an input in the range 1.5V to 5V.)
13	VREF2	
20	PHASE1	Output phase switching inputs High-level input: OUTA = high, OUT \bar{A} = low Low-level input: OUTA = low, OUT \bar{A} = high
9	PHASE2	
19	ENABLE1	Output on/off control inputs High-level input: Output off Low-level input: Output on
10	ENABLE2	
17, 18	IA1, IA2	Output current setting digital inputs. The output current is set to 1/3, 2/3 or 1 by input high/low levels to these pins.
12, 11	IB1, IB2	
21	V _{CC}	Logic block power supply voltage

LB1945D

Block Diagram

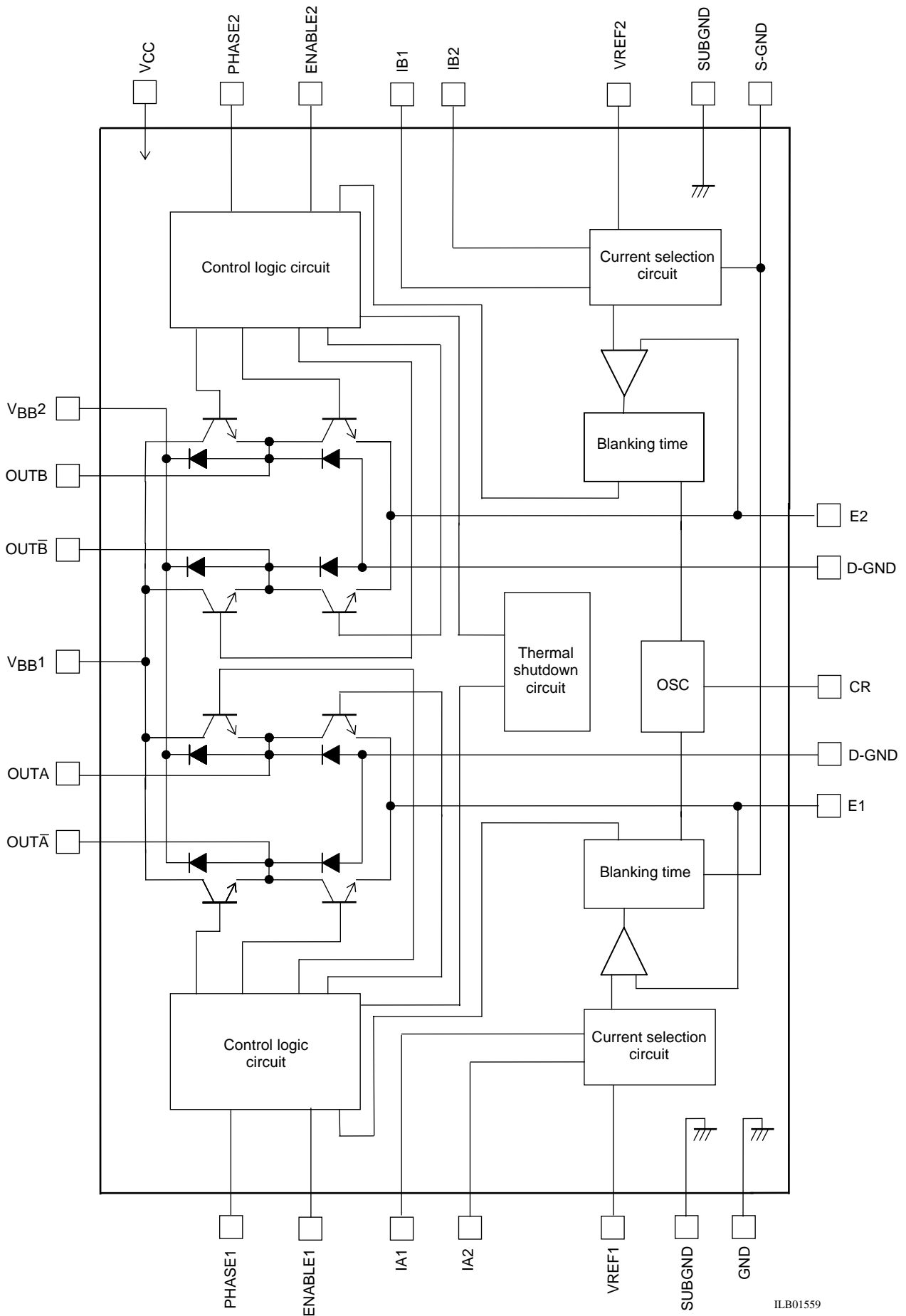

ILB01559

LB1945D

Application circuit

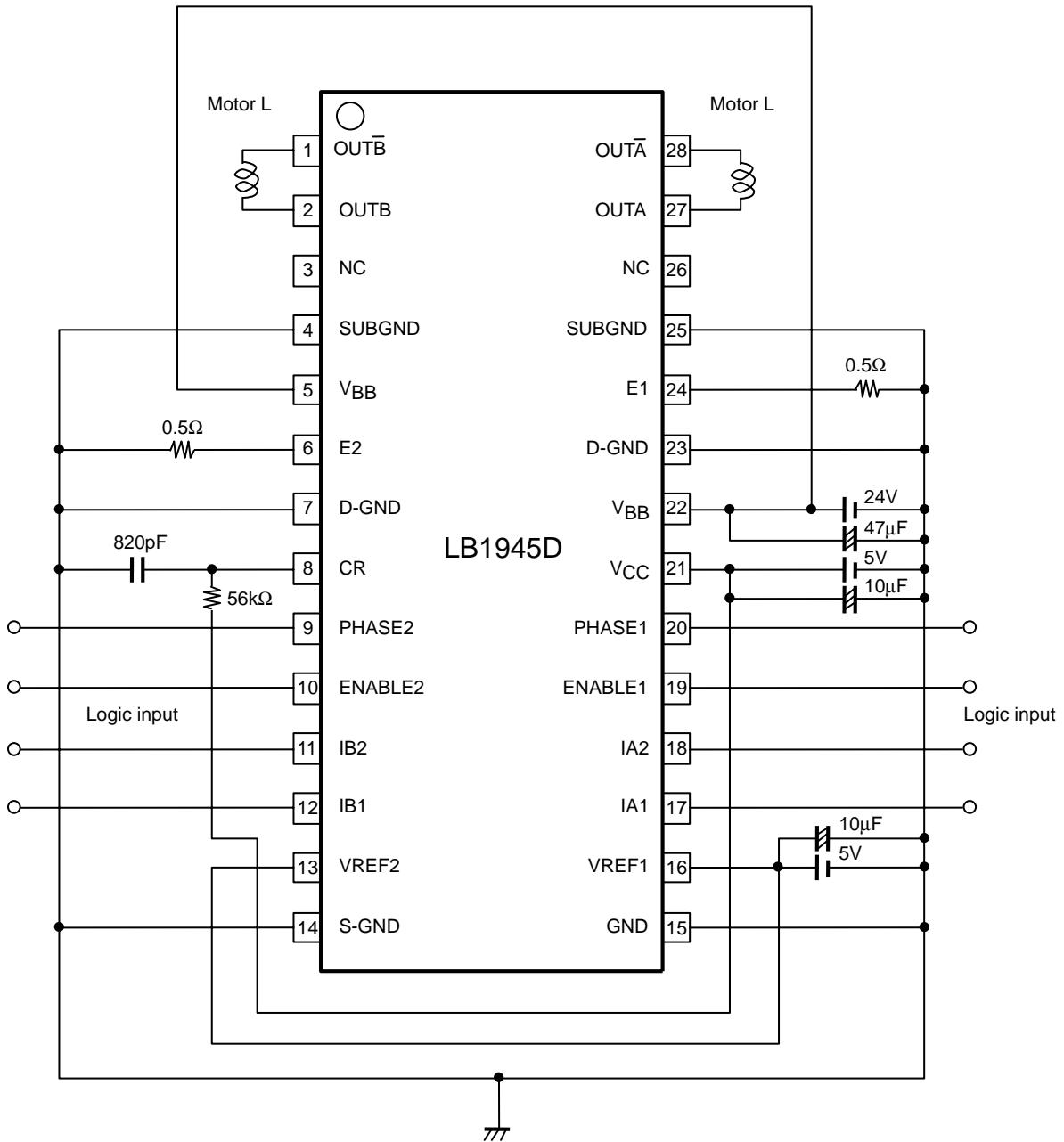

ILB01556

Truth Table

ENABLE	PHASE	OUTA	OUT \bar{A}
Low	High	High	Low
Low	Low	Low	High
High	-	OFF	OFF

I ₁	I ₂	Output current
Low	Low	$V_{ref}/(10 \times R_E) = I_{OUT}$
High	Low	$V_{ref}/(15 \times R_E) = I_{OUT} \times 2/3$
Low	High	$V_{ref}/(30 \times R_E) = I_{OUT} \times 1/3$
High	High	0

Note: The output is turned off when ENABLE is high or in the I₁ = I₂ = high state.

Clockwise/counterclockwise Operating Sequence
2-phase excitation drive

Clockwise rotation

IA1 = IA2 = IB1 = IB2 = 0

No.	PHASE1	OUTA	OUT \bar{A}	PHASE2	OUTB	OUT \bar{B}
0	0	0	1	0	0	1
1	1	1	0	0	0	1
2	1	1	0	1	1	0
3	0	0	1	1	1	0

Counterclockwise rotation

IA1 = IA2 = IB1 = IB2 = 0

No.	PHASE1	OUTA	OUT \bar{A}	PHASE2	OUTB	OUT \bar{B}
0	0	0	1	1	1	0
1	1	1	0	1	1	0
2	1	1	0	0	0	1
3	0	0	1	0	0	1

Control Sequence
2-phase excitation

Table 1

ENABLE1 = ENABLE2 = 0

NO	Phase A				Phase B			
	PH1	IA2	IA1	Current value	PH2	IB2	IB1	Current value
0	0	0	0	1	0	0	0	1
1	1	0	0	1	0	0	0	1
2	1	0	0	1	1	0	0	1
3	0	0	0	1	1	0	0	1

1-2 phase excitation - 1/2 step

Table 2

ENABLE1 = ENABLE2 = 0

No.	Phase A				Phase B			
	PH1	IA2	IA1	Current value	PH2	IB2	IB1	Current value
0	0	0	0	1	*	1	1	0
1	0	0	1	2/3	0	0	1	2/3
2	*	1	1	0	0	0	0	1
3	1	0	1	2/3	0	0	1	2/3
4	1	0	0	1	*	1	1	0
5	1	0	1	2/3	1	0	1	2/3
6	*	1	1	0	1	0	0	1
7	0	0	1	2/3	1	0	1	2/3

1-2 phase Excitation Timing Chart

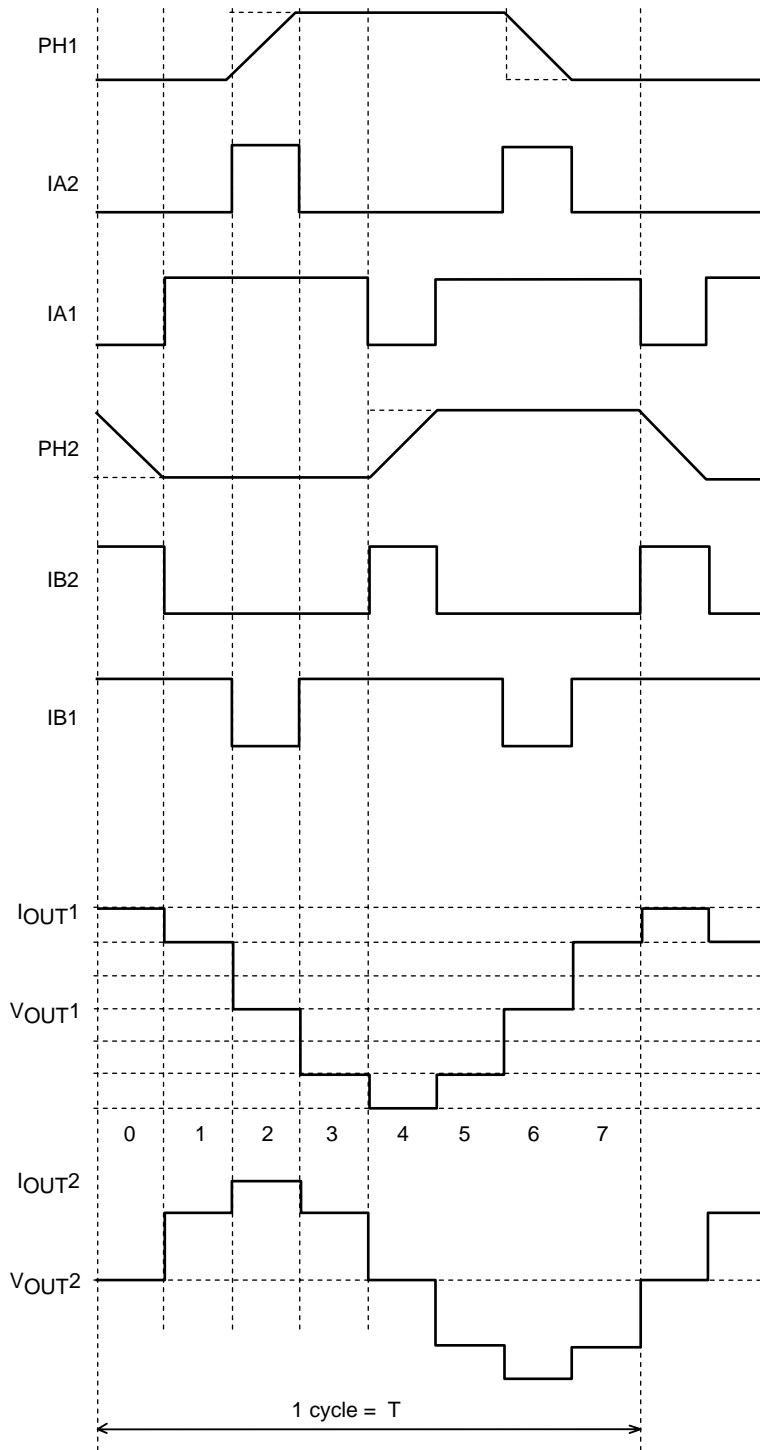

ILB01558

LB1945D

W1-2 phase excitation - about 1/4 step

Table 3

ENABLE1 = ENABLE2 = 0

NO	Phase A				Phase B			
	PH1	IA2	IA1	Current value	PH2	IB2	IB1	Current value
0	0	0	0	1	*	1	1	0
1	0	0	0	1	0	1	0	1/3
2	0	0	1	2/3	0	0	1	2/3
3	0	1	0	1/3	0	0	0	1
4	*	1	1	0	0	0	0	1
5	1	1	0	1/3	0	0	0	1
6	1	0	1	2/3	0	0	1	2/3
7	1	0	0	1	0	1	0	1/3
8	1	0	0	1	*	1	1	0
9	1	0	0	1	1	1	0	1/3
10	1	0	1	2/3	1	0	1	2/3
11	1	1	0	1/3	1	0	0	1
12	*	1	1	0	1	0	0	1
13	0	1	0	1/3	1	0	0	1
14	0	0	1	2/3	1	0	1	2/3
15	0	0	0	1	1	1	0	1/3

W1-2 phase Excitation Timing Chart

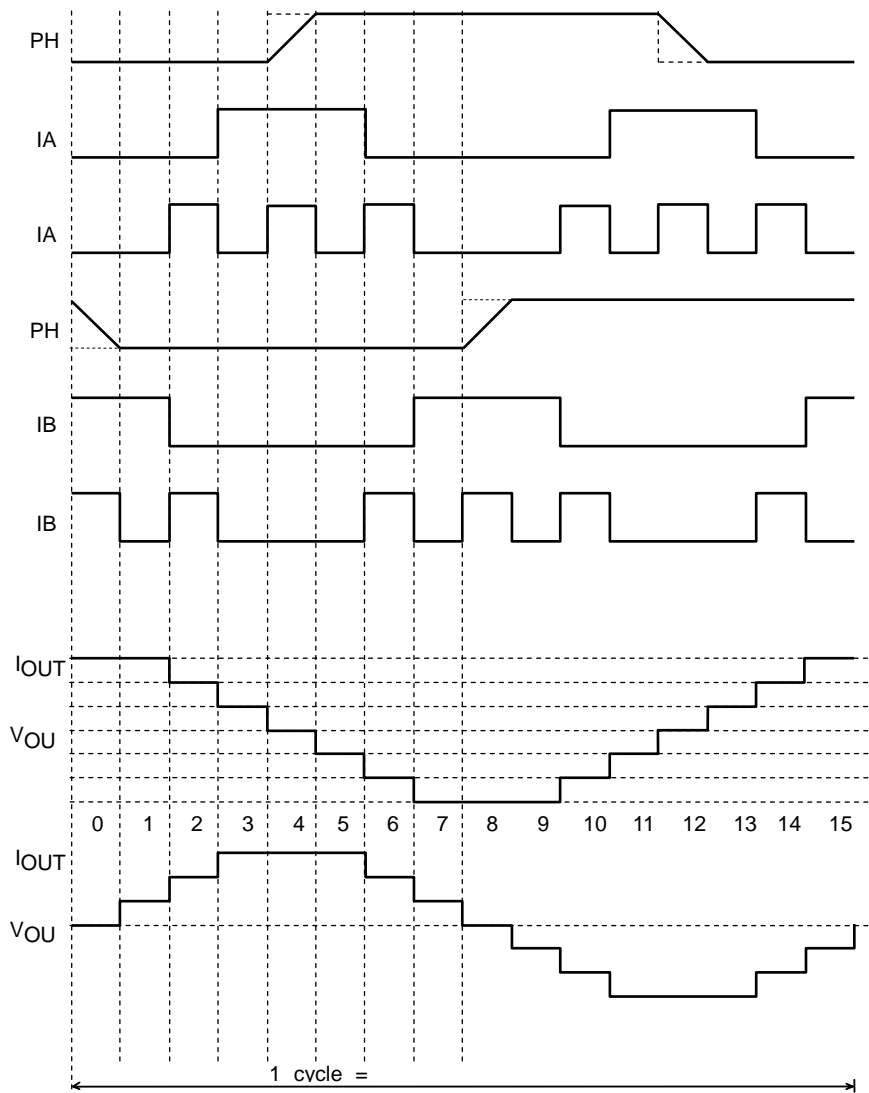

ILB01557

Simplified Equations for Determining RC Component Values

The equations for setting the RC oscillator circuit rise time (T1) and fall time (T2) are shown below.

$$T1 \approx 0.44C \times R \text{ (s)}$$

$$T2 \approx 0.72 \times (C \times R \times 1000) / (R + 1000) \text{ (s)}$$

(C:220 to 4700pF, R = 10 to 150kΩ)

The oscillator frequency must be set using the simplified equations shown above.

Note that the triangle wave fall time (T2) is also used as the noise canceller time.

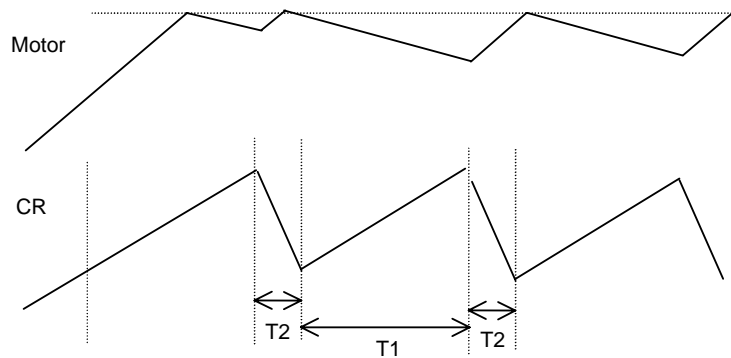

Usage Notes

1. VREF

Since the VREF pin is the input pin for the reference voltage that sets the current, applications must be designed so that noise does not appear on this pin.

2. Ground pins

Since this IC switches high currents, the following points concerning grounding must be observed.

- The fins on the package rear surface, pins 7 and 8, and pins 21 and 22 must all be grounded.
- Sections of the circuit that carry large currents must be implemented with wide lines in the printed circuit pattern, and must be physically separated from the small signal system.
- The E pin sense resistor (RE) must be position as close as possible to the IC ground (pin 14).
- The capacitors between VCC and ground and between VBB and ground must be positioned as close as possible to the VCC and VBB pins on the printed circuit pattern.

- SANYO Semiconductor Co.,Ltd. assumes no responsibility for equipment failures that result from using products at values that exceed, even momentarily, rated values (such as maximum ratings, operating condition ranges, or other parameters) listed in products specifications of any and all SANYO Semiconductor Co.,Ltd. products described or contained herein.
- SANYO Semiconductor Co.,Ltd. strives to supply high-quality high-reliability products, however, any and all semiconductor products fail or malfunction with some probability. It is possible that these probabilistic failures or malfunction could give rise to accidents or events that could endanger human lives, trouble that could give rise to smoke or fire, or accidents that could cause damage to other property. When designing equipment, adopt safety measures so that these kinds of accidents or events cannot occur. Such measures include but are not limited to protective circuits and error prevention circuits for safe design, redundant design, and structural design.
- In the event that any or all SANYO Semiconductor Co.,Ltd. products described or contained herein are controlled under any of applicable local export control laws and regulations, such products may require the export license from the authorities concerned in accordance with the above law.
- No part of this publication may be reproduced or transmitted in any form or by any means, electronic or mechanical, including photocopying and recording, or any information storage or retrieval system, or otherwise, without the prior written consent of SANYO Semiconductor Co.,Ltd.
- Any and all information described or contained herein are subject to change without notice due to product/technology improvement, etc. When designing equipment, refer to the "Delivery Specification" for the SANYO Semiconductor Co.,Ltd. product that you intend to use.
- Information (including circuit diagrams and circuit parameters) herein is for example only; it is not guaranteed for volume production.
- Upon using the technical information or products described herein, neither warranty nor license shall be granted with regard to intellectual property rights or any other rights of SANYO Semiconductor Co.,Ltd. or any third party. SANYO Semiconductor Co.,Ltd. shall not be liable for any claim or suits with regard to a third party's intellectual property rights which has resulted from the use of the technical information and products mentioned above.

This catalog provides information as of April, 2007. Specifications and information herein are subject to change without notice.