

Silicon NPN Power Transistors

2SC3092

DESCRIPTION

- With TO-3 package
- High breakdown voltage
- Fast switching speed.
- Wide area of safe operation

APPLICATIONS

- 500V/7A switching regulator applications

PINNING(see Fig.2)

PIN	DESCRIPTION
1	Base
2	Emitter
3	Collector

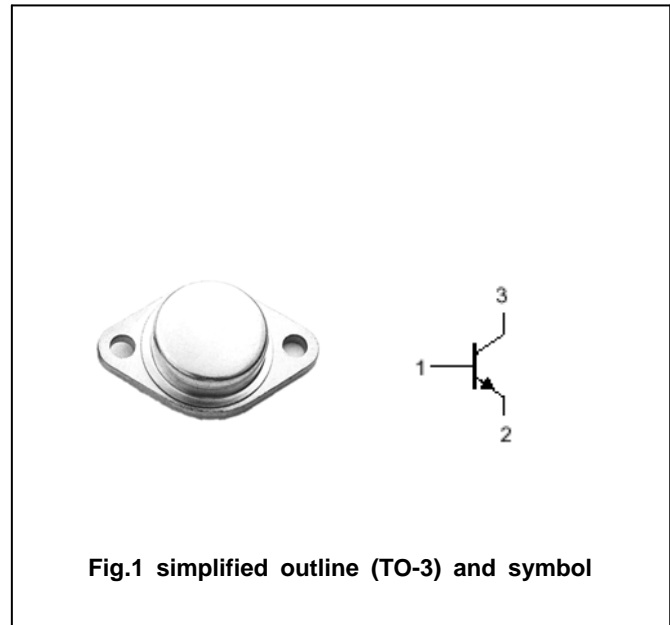
ABSOLUTE MAXIMUM RATINGS($T_C=25^{\circ}\text{C}$)

SYMBOL	PARAMETER	CONDITIONS	VALUE	UNIT
V_{CBO}	Collector-base voltage	Open emitter	800	V
V_{CEO}	Collector-emitter voltage	Open base	500	V
V_{EBO}	Emitter-base voltage	Open collector	7	V
I_C	Collector current		7	A
I_{CP}	Collector current-peak	$PW \leq 300 \mu s$, Duty Cycle $\leq 10\%$	14	A
I_B	Base current		3	A
P_C	Collector power dissipation	$T_C=25^{\circ}\text{C}$	90	W
T_j	Junction temperature		150	$^{\circ}\text{C}$
T_{stg}	Storage temperature		-55~150	$^{\circ}\text{C}$

Silicon NPN Power Transistors

2SC3092

CHARACTERISTICS

T_j=25°C unless otherwise specified

SYMBOL	PARAMETER	CONDITIONS	MIN	TYP.	MAX	UNIT
V _{(BR)CEO}	Collector-emitter breakdown voltage	I _C =5mA ; R _{BE} =∞	500			V
V _{(BR)CBO}	Collector-base breakdown voltage	I _C =1mA ; I _E =0	800			V
V _{(BR)EBO}	Emitter-base breakdown voltage	I _E =1mA ; I _C =0	7			V
V _{CE(sat)}	Collector-emitter saturation voltage	I _C =3A; I _B =0.6A			1.0	V
V _{BE(sat)}	Base-emitter saturation voltage	I _C =3A; I _B =0.6A			1.5	V
I _{CBO}	Collector cut-off current	V _{CB} =500V; I _E =0			10	μ A
I _{EBO}	Emitter cut-off current	V _{EB} =5V; I _C =0			10	μ A
h _{FE-1}	DC current gain	I _C =0.6A ; V _{CE} =5V	15		50	
h _{FE-2}	DC current gain	I _C =3A ; V _{CE} =5V	8			
C _{OB}	Output capacitance	I _E =0 ; V _{CB} =10V, f=1MHz		80		pF
f _T	Transition frequency	I _C =0.6 A ; V _{CE} =10V		18		MHz

Switching times

t _{on}	Turn-on time	I _C =4A; I _{B1} =0.8A; I _{B2} =-1.6A V _{CC} =200V ,R _L =50 Ω			0.5	μ s
t _s	Storage time				3.0	μ s
t _f	Fall time				0.3	μ s

◆ h_{FE-1} classifications

L	M	N
15-30	20-40	30-50

PACKAGE OUTLINE

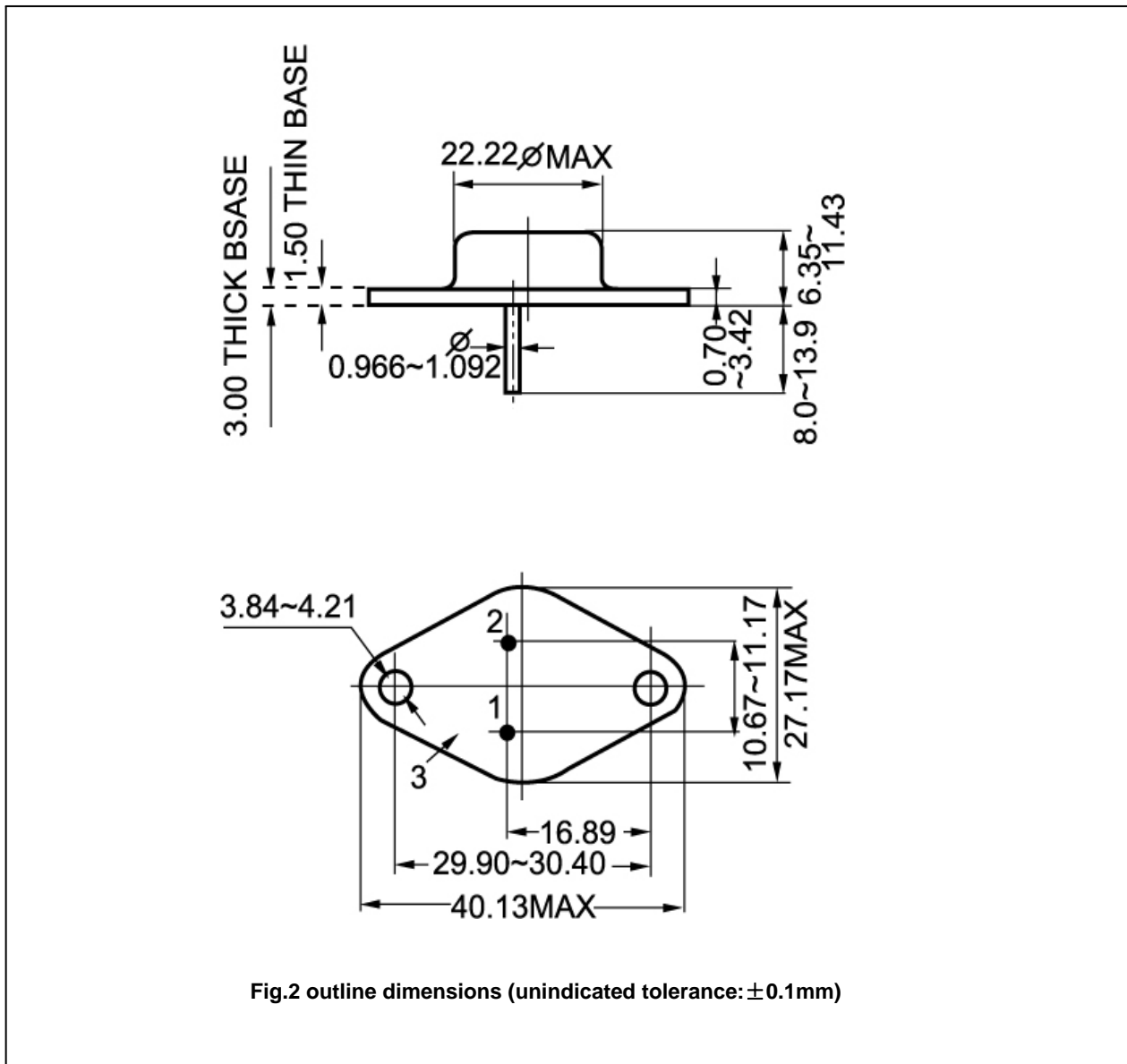

Fig.2 outline dimensions (unindicated tolerance: ± 0.1 mm)