



SANYO Semiconductors

## DATA SHEET

# LB1941GP

Monolithic Linear IC  
For Digital Cameras  
Constant Current  
Forward/Reverse Driver

## Overview

The LB1941GP is a single-channel forward/reverse driver IC that provides a constant current control function. Its low-saturation output makes it appropriate for voice coil motor control, and it is optimal for use as the shutter driver IC in digital cameras.

## Functions

- High-performance dual operational amplifier
- Constant current control ( $I_O = 400 \text{ mA}$  when  $R_f = 0.5\Omega$ )
- Built-in thermal protection circuit
- Includes a rapid charge/rapid discharge circuit for stable shutter operation.
- Built-in reference voltage circuit (0.2 V typical)
- Ultraminiature package (VCT16 (2.6mm × 2.6mm))

## Specifications

### Maximum Ratings at $T_a = 25^\circ\text{C}$

Parameter	Symbol	Conditions	Ratings	Unit
Maximum supply voltage	$V_{CC \text{ max}}$		-0.3 to +10.5	V
Output current	$I_O \text{ max}$		600	mA
Output applied voltage	$V_O \text{ max}$		-0.3 to $V_{CC}+0.3$	V
Input applied voltage	$V_{IN \text{ max}}$	IN1, IN2	-0.3 to +10.5	V
Allowable power dissipation	$P_d \text{ max}$	Mounted on a specified board.*	0.7	W
Operating temperature	$T_{opr}$		-20 to +75	$^\circ\text{C}$
Storage temperature	$T_{stg}$		-55 to +150	$^\circ\text{C}$

Note\*: Mounted on a board: 50×40×10.8 mm<sup>3</sup>: glass epoxy four-layer.

### Allowable Operating Range at $T_a = 25^\circ\text{C}$

Parameter	Symbol	Conditions	Ratings	Unit
Function-guaranteed voltage range	VOPR		2.5 to 10	V
Constant-current set range	$I_{OUT}$	Set with RFG-GND resistance	50 to 500	mA
Input low level voltage	$V_{IL}$	IN1, IN2	-0.3 to +0.5	V
Input high level voltage	$V_{IH}$	IN1, IN2	2.0 to 10	V

■ Any and all SANYO Semiconductor products described or contained herein do not have specifications that can handle applications that require extremely high levels of reliability, such as life-support systems, aircraft's control systems, or other applications whose failure can be reasonably expected to result in serious physical and/or material damage. Consult with your SANYO Semiconductor representative nearest you before using any SANYO Semiconductor products described or contained herein in such applications.

■ SANYO Semiconductor assumes no responsibility for equipment failures that result from using products at values that exceed, even momentarily, rated values (such as maximum ratings, operating condition ranges, or other parameters) listed in products specifications of any and all SANYO Semiconductor products described or contained herein.

**SANYO Semiconductor Co., Ltd.**

TOKYO OFFICE Tokyo Bldg., 1-10, 1 Chome, Ueno, Taito-ku, TOKYO, 110-8534 JAPAN

# LB1941GP

## Electrical Characteristics at $T_a = 25^\circ\text{C}$

Parameter	Symbol	Conditions	Ratings			Unit
			min	typ	max	
Standby Current dissipation	$I_{STB}$	$V_{CC} = 10\text{V}$			1.0	mV
<b>Constant-current H bridge drive circuit</b>						
Output saturation voltage 1	$V_{OUT11}$	$V_{CC} = 3\text{V}, I_O = 200\text{mA}$ (Lower side)		0.08	0.15	$\mu\text{A}$
	$V_{OUT12}$	$V_{CC} = 3\text{V}, I_O = 200\text{mA}$ (Upper side)		0.12	0.23	V
	$V_{OUT1}$	$V_{CC} = 3\text{V}, I_O = 200\text{mA}$ (Upper + Lower side)		0.20	0.35	V
Output saturation voltage 2 *	$V_{OUT21}$	$V_{CC} = 4\text{V}, I_O = 500\text{mA}$ (Lower side)		0.25	0.38	V
	$V_{OUT22}$	$V_{CC} = 4\text{V}, I_O = 500\text{mA}$ (Upper side)		0.35	0.52	V
	$V_{OUT2}$	$V_{CC} = 4\text{V}, I_O = 500\text{mA}$ (Upper + Lower side)		0.60	0.90	V
Output constant current 1	$I_{OUT1}$	$V_{CC} = 4\text{V}, R_L = 3\Omega, R_F = 1\Omega$	190	200	210	mA
Output constant current 2 *	$I_{OUT2}$	$V_{CC} = 4\text{V}, R_L = 3\Omega, R_F = 0.5\Omega$	375	400	424	mA
Temperature dependence of output constant current (reference $T_a = 25^\circ\text{C}$ )	$\Delta I_O$	$V_{CC} = 4\text{V}, R_L = 3\Omega, R_F = 0.5\Omega$ * ( $T_a = -10$ to $+60^\circ\text{C}$ )	-2		+2	%
Operating current dissipation	$I_{CC}$	$V_{CC} = 4\text{V}, R_L = 0\Omega$ , (No load, full drive)		14	21	mA
Thermal protection operating temperature	TSD	*	150	180	210	$^\circ\text{C}$
<b>Control input circuit</b>						
Control pin maximum input current	$I_{IH1}$	$V_{IH} = 5.5\text{V}, V_{CC} = 5.5\text{V}$		80	100	$\mu\text{A}$
	$I_{IH2}$	$V_{IH} = 10\text{V}, V_{CC} = 10\text{V}$		145	200	$\mu\text{A}$
	$I_{IL}$	$V_{IL} = \text{GND}$	-1		0	$\mu\text{A}$

Note\*: Design guarantee: Characteristics shown here are design targets and measurement with independent unit is not made before shipment.

## Package Dimensions

unit : mm (typ)

3318

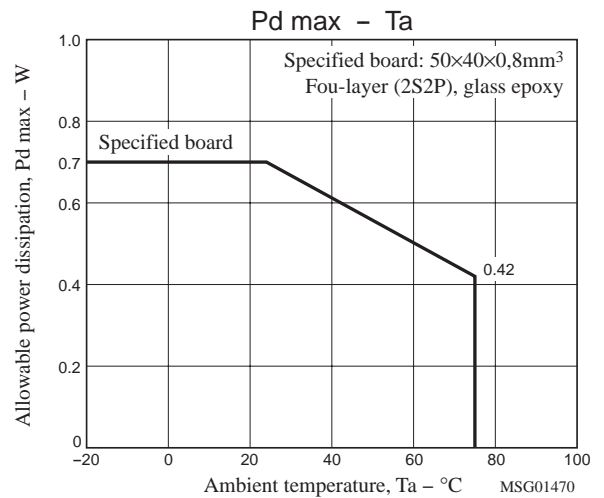
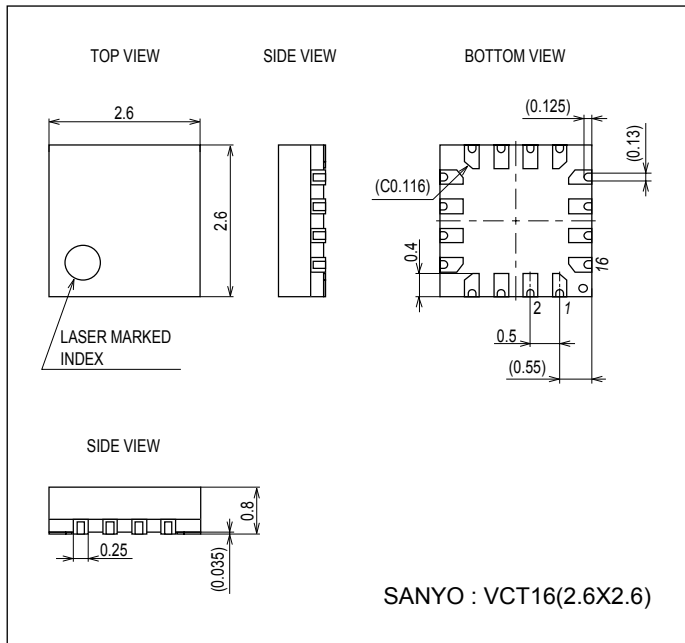

# LB1941GP

## Pin Assignment

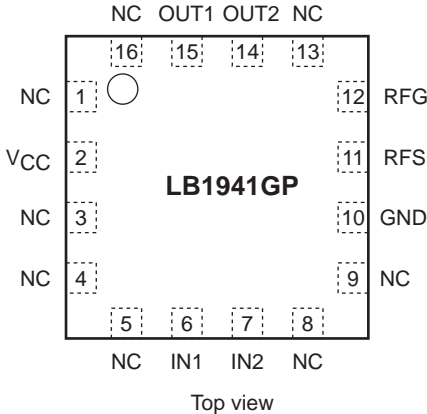

## Block Diagram

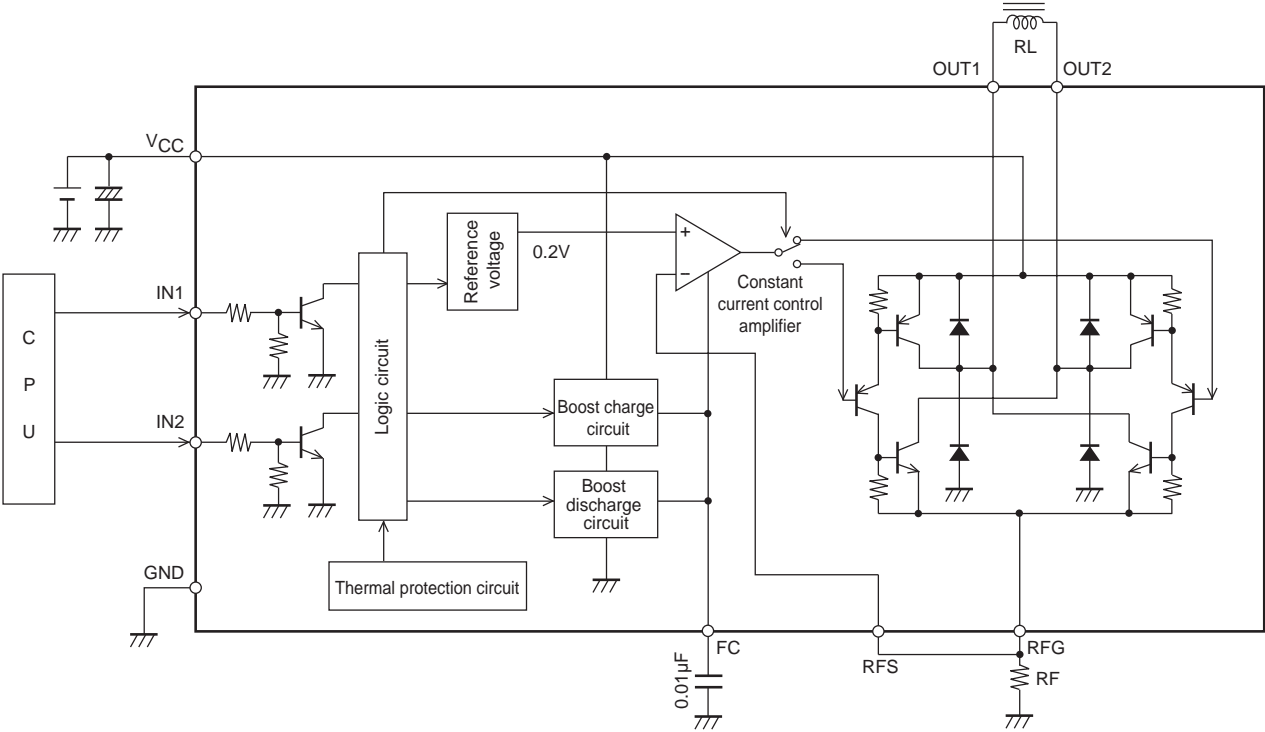

ILB01540

**Truth Table**

Input		Output		Mode
IN1	IN2	OUT1	OUT2	
L	L	OFF	OFF	Standby 1*
H	L	H	L	Forward rotation
L	H	L	H	Reverse rotation
H	H	OFF	OFF	Standby 2*

**Cautions for use**

Standby states 1 and 2 in the above truth table differ as follows:

Standby state 1 .....All circuits in IC are not operating and the current dissipation is almost zero.

Standby state 2 .....The constant-current control amplifier output in IC is in the full drive condition. Both OUT1 and OUT2 are OFF. The current dissipation is a few mA.

During mode transfer from the standby state 1 to forward (reverse) rotation, the current rises from the output current zero condition to the required constant current value. On the other hand, during mode transfer from the standby state 2 to forward (reverse) rotation, full drive is applied once to the output, then the current lowers to the required current value.

Therefore, select the standby 1 state when putting IC in the standby state. A typical drive sequence is shown in the figure below.

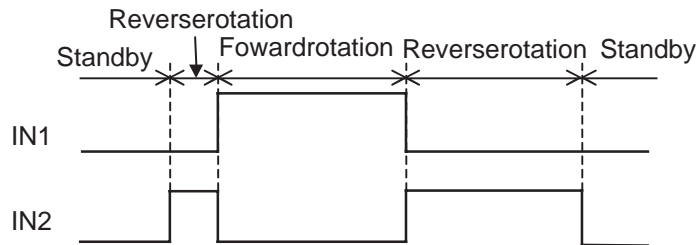

**Boost charge and discharge circuits**

In order to keep the output response time constant during mode transfer from the standby state to forward (reverse) rotation, this IC incorporates boost charge and discharge circuits for external capacitor connected to the FC pin.

The external capacitor connected to the FC pin is for output phase compensation (to suppress oscillation), for which 0.01 to 0.1μF is recommended. Note that increase in the capacitor value results in increase in the time necessary for the constant current control to rise.

- Specifications of any and all SANYO Semiconductor products described or contained herein stipulate the performance, characteristics, and functions of the described products in the independent state, and are not guarantees of the performance, characteristics, and functions of the described products as mounted in the customer's products or equipment. To verify symptoms and states that cannot be evaluated in an independent device, the customer should always evaluate and test devices mounted in the customer's products or equipment.
- SANYO Semiconductor Co., Ltd. strives to supply high-quality high-reliability products. However, any and all semiconductor products fail with some probability. It is possible that these probabilistic failures could give rise to accidents or events that could endanger human lives, that could give rise to smoke or fire, or that could cause damage to other property. When designing equipment, adopt safety measures so that these kinds of accidents or events cannot occur. Such measures include but are not limited to protective circuits and error prevention circuits for safe design, redundant design, and structural design.
- In the event that any or all SANYO Semiconductor products (including technical data, services) described or contained herein are controlled under any of applicable local export control laws and regulations, such products must not be exported without obtaining the export license from the authorities concerned in accordance with the above law.
- No part of this publication may be reproduced or transmitted in any form or by any means, electronic or mechanical, including photocopying and recording, or any information storage or retrieval system, of otherwise, without the prior written permission of SANYO Semiconductor Co., Ltd.
- Any and all information described or contained herein are subject to change without notice due to product/technology improvement, etc. When designing equipment, refer to the "Delivery Specification" for the SANYO Semiconductor product that you intend to use.
- Information (including circuit diagrams and circuit parameters) herein is for example only; it is not guaranteed for volume production. SANYO Semiconductor believes information herein is accurate and reliable, but no guarantees are made or implied regarding its use or any infringements of intellectual property rights or other rights of third parties.

This catalog provides information as of January, 2007. Specifications and information herein are subject to change without notice.