

Silicon NPN Power Transistors

2SC3041

DESCRIPTION

- With TO-3 package
- Fast switching speed
- Wide area of safe operation
- High breakdown voltage

APPLICATIONS

- For switching regulator applications

PINNING(see Fig.2)

PIN	DESCRIPTION
1	Base
2	Emitter
3	Collector

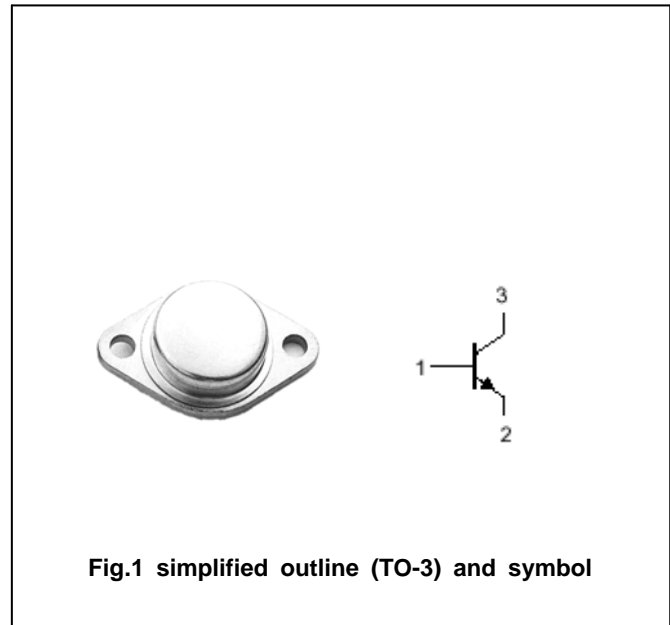
ABSOLUTE MAXIMUM RATINGS($T_C=25^\circ\text{C}$)

SYMBOL	PARAMETER	CONDITIONS	VALUE	UNIT
V_{CBO}	Collector-base voltage	Open emitter	500	V
V_{CEO}	Collector-emitter voltage	Open base	400	V
V_{EBO}	Emitter-base voltage	Open collector	7	V
I_C	Collector current		8	A
I_{CP}	Collector current-pulse	$PW \leq 300 \mu s, \text{Duty cycle} \leq 10\%$	16	A
I_B	Base current		3	A
P_C	Collector power dissipation	$T_C=25^\circ\text{C}$	90	W
T_j	Junction temperature		150	$^\circ\text{C}$
T_{stg}	Storage temperature		-55~150	$^\circ\text{C}$

Silicon NPN Power Transistors

2SC3041

CHARACTERISTICS

T_j=25°C unless otherwise specified

SYMBOL	PARAMETER	CONDITIONS	MIN	TYP.	MAX	UNIT
V _{(BR)CEO}	Collector-emitter breakdown voltage	I _C =10mA ; R _{BE} =∞	400			V
V _{(BR)CBO}	Collector-base breakdown voltage	I _C =1mA; I _E =0	500			V
V _{(BR)EBO}	Emitter-base breakdown voltage	I _E =1mA; I _C =0	7			V
V _{CE(sat)}	Collector-emitter saturation voltage	I _C =4A; I _B =0.8A			1.0	V
V _{BE(sat)}	Base-emitter saturation voltage	I _C =4A; I _B =0.8A			1.5	V
I _{CBO}	Collector cut-off current	V _{CB} =400V; I _E =0			10	μ A
I _{EBO}	Emitter cut-off current	V _{EB} =5V; I _C =0			10	μ A
h _{FE-1}	DC current gain	I _C =0.8A ; V _{CE} =5V	15			
h _{FE-2}	DC current gain	I _C =4A ; V _{CE} =5V	8			
f _T	Transition frequency	I _C =0.8A ; V _{CE} =10V		20		MHz
C _{ob}	Output capacitance	I _E =0; V _{CB} =10V, f=1MHz		80		pF

PACKAGE OUTLINE

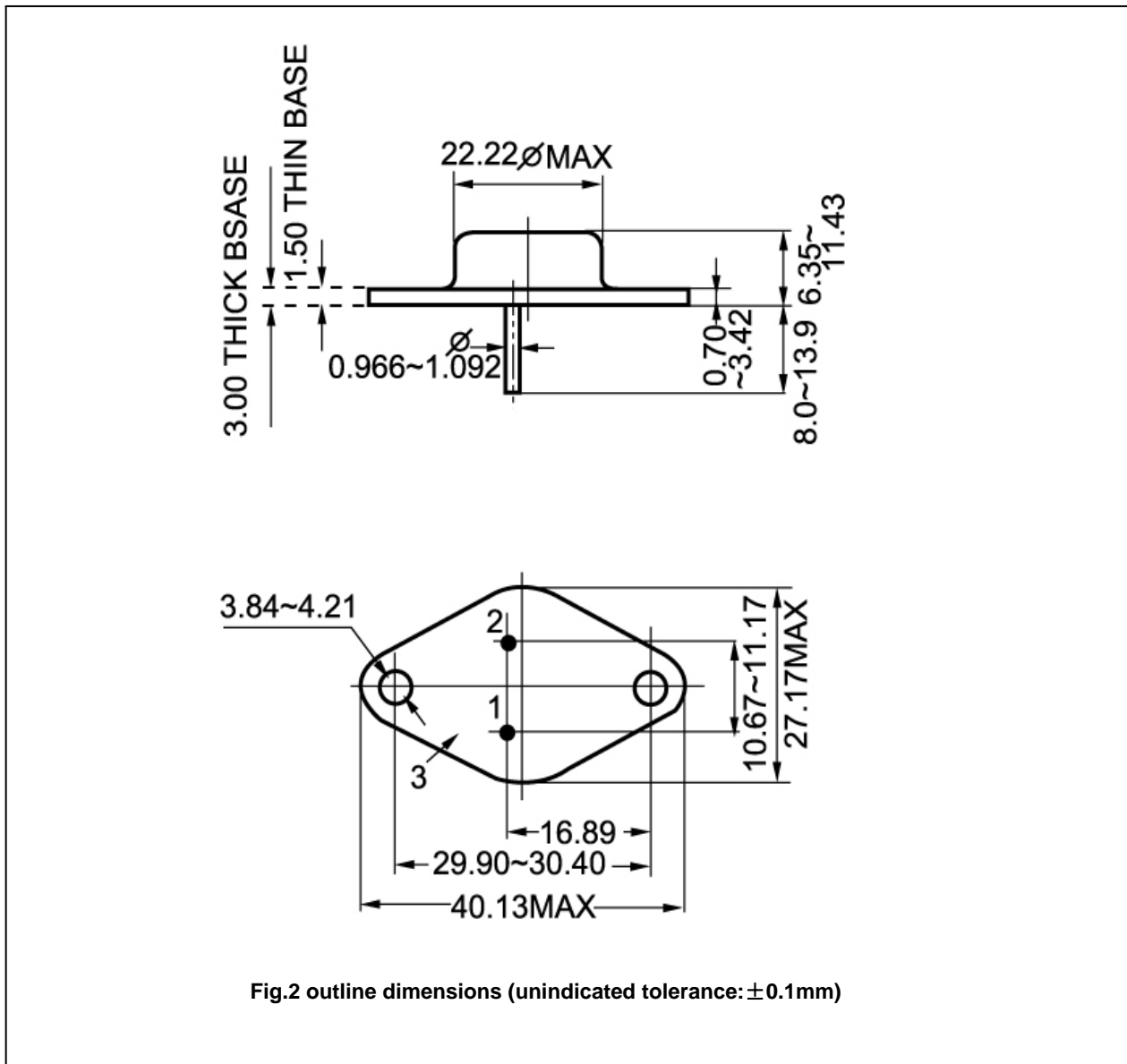

Fig.2 outline dimensions (unindicated tolerance: ± 0.1 mm)