

Silicon NPN Power Transistors

2SC2335F

DESCRIPTION

- With TO-220F package
- Collector-emitter sustaining voltage
 $V_{CEO(sus)}=400V(\text{Min})$
- Collector-emitter saturation voltage
 $V_{CE(sat)}=1.0V(\text{Max.})@I_C=3.0A, I_B=0.6A$
- Switching time- $t_f=1.0\mu s(\text{Max.})@I_C=3.0A$

APPLICATIONS

- Designed for use in high-voltage ,high-speed ,power switching in inductive circuit, particularly suited for 115 and 220V switch-mode applications such as switching regulator's ,inverters,,DC-DC and converter

PINNING

PIN	DESCRIPTION
1	Base
2	Collector
3	Emitter

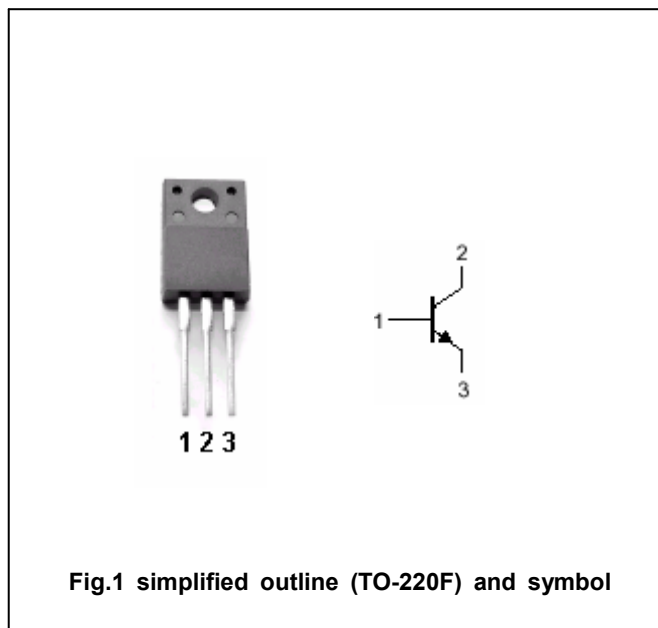
Absolute maximum ratings($T_a=25^\circ\text{C}$)

SYMBOL	PARAMETER	CONDITIONS	VALUE	UNIT
V_{CBO}	Collector-base voltage	Open emitter	500	V
V_{CEO}	Collector-emitter voltage	Open base	400	V
V_{EBO}	Emitter-base voltage	Open collector	7	V
I_C	Collector current		7	A
I_{CM}	Collector current-peak		15	A
I_B	Base current		3.5	A
P_D	Total power dissipation	$T_C=25^\circ\text{C}$	40	W
T_j	Junction temperature		150	$^\circ\text{C}$
T_{stg}	Storage temperature		-50~150	$^\circ\text{C}$

Silicon NPN Power Transistors

2SC2335F

CHARACTERISTICS

T_j=25°C unless otherwise specified

SYMBOL	PARAMETER	CONDITIONS	MIN	TYP.	MAX	UNIT
V _{(SUS)CEO}	Collector-emitter sustaining voltage	I _C =3.0A ; I _{B1} =0.6A, L=1mH	400			V
V _{CEsat}	Collector-emitter saturation voltage	I _C =3A; I _B =0.6A			1.0	V
V _{BEsat}	Base-emitter saturation voltage	I _C =3A; I _B =0.6A			1.2	V
I _{CBO}	Collector cut-off current	V _{CB} =400V ; I _E =0			10	μA
I _{CEX}	Collector cut-off current	V _{CE} =400V ; V _{BE(off)} =-1.5V T _C =125°C			10 1.0	μA mA
I _{EBO}	Emitter cut-off current	V _{EB} =5V; I _C =0			10	μA
h _{FE-1}	DC current gain	I _C =0.1A ; V _{CE} =5V	20			
h _{FE-2}	DC current gain	I _C =1.0A ; V _{CE} =5V	20		80	
h _{FE-3}	DC current gain	I _C =3.0A ; V _{CE} =5V	10			

Switching times

t _{on}	Turn-on time	V _{CC} =150V; I _C =3.0A; I _{B1} =-I _{B2} =600mA; R _L =50Ω			1.0	μs
t _{stg}	Storage time				2.5	μs
t _f	Fall time				1.0	μs

◆ h_{FE-2} Classifications

R	O	Y
20-40	30-60	40-80

Silicon NPN Power Transistors

2SC2335F

PACKAGE OUTLINE

