



STM8457

Dual Enhancement Mode Field Effect Transistor (N and P Channel)

| PRODUCT SUMMARY (N-Channel) | | |
|-----------------------------|----------------|--------------------------------|
| V _{DSS} | I _D | R _{DS(ON)} (mΩ) Max |
| 40V | 6A | 26 @ V _{GS} = 10V |
| | | 33 @ V _{GS} = 4.5V |

| PRODUCT SUMMARY (P-Channel) | | |
|-----------------------------|----------------|--------------------------------|
| V _{DSS} | I _D | R _{DS(ON)} (mΩ) Max |
| -40V | -5A | 42 @ V _{GS} = -10V |
| | | 62 @ V _{GS} = -4.5V |

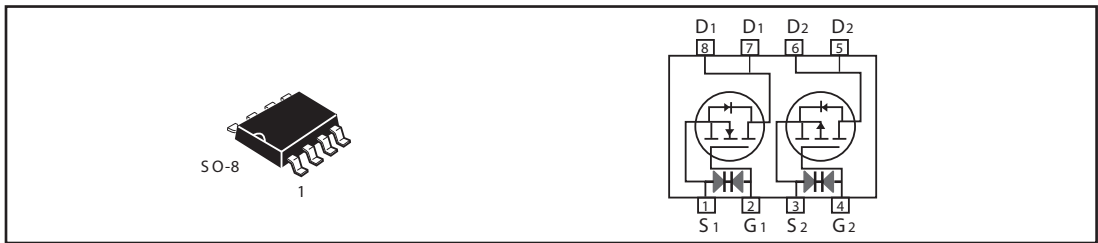

ABSOLUTE MAXIMUM RATINGS (T_A=25°C unless otherwise noted)

| Parameter | | Symbol | N-Channel | P-Channel | Unit |
|--|----------------------|-----------------------------------|------------|-----------|------|
| Drain-Source Voltage | | V _{DS} | 40 | -40 | V |
| Gate-Source Voltage | | V _{GS} | ±20 | ±20 | V |
| Drain Current-Continuous ^a @ T _a | 25°C | I _D | 6 | -5 | A |
| | 70°C | | 5.1 | -4.2 | A |
| -Pulsed ^b | | I _{DM} | 28 | -20 | A |
| Drain-Source Diode Forward Current ^a | | I _S | 1.7 | -1.7 | A |
| Maximum Power Dissipation ^a | T _a =25°C | P _D | 2 | | W |
| | T _a =70°C | | 1.44 | | |
| Operating Junction and Storage Temperature Range | | T _J , T _{STG} | -55 to 150 | | °C |

THERMAL CHARACTERISTICS

| | | | |
|--|------------------|------|------|
| Thermal Resistance, Junction-to-Ambient ^a | R _{θJA} | 62.5 | °C/W |
|--|------------------|------|------|

STM8457

N-Channel ELECTRICAL CHARACTERISTICS (TA=25 °C unless otherwise noted)

| Parameter | Symbol | Condition | Min | Typ ^c | Max | Unit |
|--|---------------------|--|-----|------------------|-----|-------|
| OFF CHARACTERISTICS | | | | | | |
| Drain-Source Breakdown Voltage | BV _{DSS} | V _{GS} = 0V, I _D = 250uA | 40 | | | V |
| Zero Gate Voltage Drain Current | I _{DSS} | V _{DS} = 32V, V _{GS} = 0V | | | 1 | uA |
| Gate-Body Leakage | I _{GSS} | V _{GS} = ±20V, V _{DS} = 0V | | | ±10 | uA |
| ON CHARACTERISTICS^b | | | | | | |
| Gate Threshold Voltage | V _{GS(th)} | V _{DS} = V _{GS} , I _D = 250uA | 1.0 | 1.8 | 3.0 | V |
| Drain-Source On-State Resistance | R _{DS(ON)} | V _{GS} = 10V, I _D = 5A | | 20 | 26 | m ohm |
| | | V _{GS} = 4.5V, I _D = 4A | | 27 | 33 | m ohm |
| On-State Drain Current | I _{D(ON)} | V _{DS} = 5V, V _{GS} = 10V | 20 | | | A |
| Forward Transconductance | g _{FS} | V _{DS} = 5V, I _D = 5A | | 15 | | S |
| DYNAMIC CHARACTERISTICS^c | | | | | | |
| Input Capacitance | C _{ISS} | V _{DS} = 20V, V _{GS} = 0V f = 1.0MHz | | 750 | | pF |
| Output Capacitance | C _{OSS} | | | 125 | | pF |
| Reverse Transfer Capacitance | C _{RSS} | | | 75 | | pF |
| SWITCHING CHARACTERISTICS^c | | | | | | |
| Turn-On Delay Time | t _{D(ON)} | V _{DD} = 20V I _D = 1 A V _{GS} = 10V R _{GEN} = 3.3 ohm | | 13 | | ns |
| Rise Time | t _r | | | 11 | | ns |
| Turn-Off Delay Time | t _{D(OFF)} | | | 37 | | ns |
| Fall Time | t _f | | | 10 | | ns |
| Total Gate Charge | Q _g | V _{DS} = 24V, I _D = 5A, V _{GS} = 10V | | 12.5 | | nC |
| | | V _{DS} = 24V, I _D = 5A, V _{GS} = 4.5V | | 6.4 | | nC |
| Gate-Source Charge | Q _{gs} | V _{DS} = 24V, I _D = 5 A V _{GS} = 4.5V | | 1.8 | | nC |
| Gate-Drain Charge | Q _{gd} | | | 3.6 | | nC |

STM8457

P-Channel ELECTRICAL CHARACTERISTICS (TA=25 °C unless otherwise noted)

| Parameter | Symbol | Condition | Min | Typ ^c | Max | Unit |
|--|---------------------|--|------|------------------|------|-------|
| OFF CHARACTERISTICS | | | | | | |
| Drain-Source Breakdown Voltage | BV _{DSS} | V _{GS} =0V, I _D =-250uA | -40 | | | V |
| Zero Gate Voltage Drain Current | I _{DSS} | V _{DS} =-32V, V _{GS} =0V | | | -1 | uA |
| Gate-Body Leakage | I _{GSS} | V _{GS} =±20V, V _{DS} =0V | | | ±10 | uA |
| ON CHARACTERISTICS^b | | | | | | |
| Gate Threshold Voltage | V _{GS(th)} | V _{DS} =V _{GS} , I _D =-250uA | -1.0 | -1.8 | -3.0 | V |
| Drain-Source On-State Resistance | R _{DS(ON)} | V _{GS} =-10V, I _D =-4A | | 35 | 42 | m ohm |
| | | V _{GS} =-4.5V, I _D =-3A | | 54 | 62 | m ohm |
| On-State Drain Current | I _{D(ON)} | V _{DS} =-5V, V _{GS} =-10V | 16 | | | A |
| Forward Transconductance | g _{FS} | V _{DS} =-5V, I _D =-4A | | 10 | | S |
| DYNAMIC CHARACTERISTICS^c | | | | | | |
| Input Capacitance | C _{ISS} | V _{DS} =-20V, V _{GS} =0V f=1.0MHz | | 960 | | pF |
| Output Capacitance | C _{OSS} | | | 142 | | pF |
| Reverse Transfer Capacitance | C _{RSS} | | | 75 | | pF |
| SWITCHING CHARACTERISTICS^c | | | | | | |
| Turn-On Delay Time | t _{D(ON)} | V _D =-20V I _D =-1A V _{GEN} =-10V R _{GEN} =3.3 ohm | | 15 | | ns |
| Rise Time | t _r | | | 13 | | ns |
| Turn-Off Delay Time | t _{D(OFF)} | | | 66 | | ns |
| Fall Time | t _f | | | 25 | | ns |
| Total Gate Charge | Q _g | V _{DS} =-24V, I _D =-4A, V _{GS} =-10V | | 15.6 | | nC |
| | | V _{DS} =-24V, I _D =-4A, V _{GS} =-4.5V | | 7.7 | | nC |
| Gate-Source Charge | Q _{gs} | V _{DS} =-24V, I _D =-4A V _{GS} =-4.5V | | 2.3 | | nC |
| Gate-Drain Charge | Q _{gd} | | | 4.3 | | nC |

STM8457

ELECTRICAL CHARACTERISTICS ($T_A=25^{\circ}\text{C}$ unless otherwise noted)

| Parameter | Symbol | Condition | Min | Typ ^c | Max | Unit |
|---|----------|----------------------------|------|------------------|------|------|
| DRAIN-SOURCE DIODE CHARACTERISTICS^b | | | | | | |
| Diode Forward Voltage | V_{SD} | $V_{GS} = 0V, I_s = 1.7A$ | N-Ch | 0.78 | 1.2 | V |
| | | $V_{GS} = 0V, I_s = -1.7A$ | P-Ch | -0.77 | -1.2 | |

Notes

- a. Surface Mounted on FR4 Board, $t \leq 10\text{sec}$.
 - b. Pulse Test: Pulse Width $\leq 300\mu\text{s}$, Duty Cycle $\leq 2\%$.
 - c. Guaranteed by design, not subject to production testing.
- N-Channel

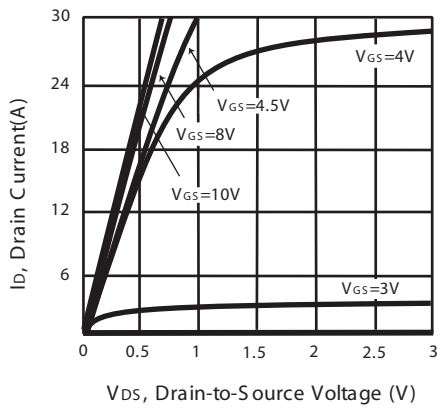

Figure 1. Output Characteristics

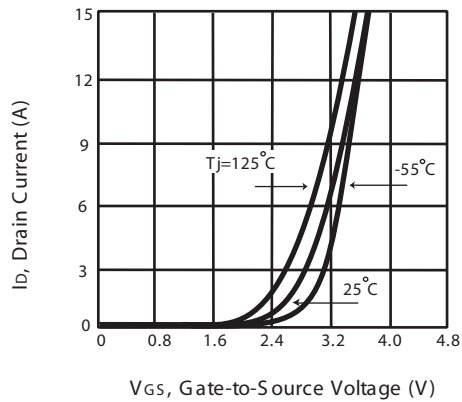

Figure 2. Transfer Characteristics

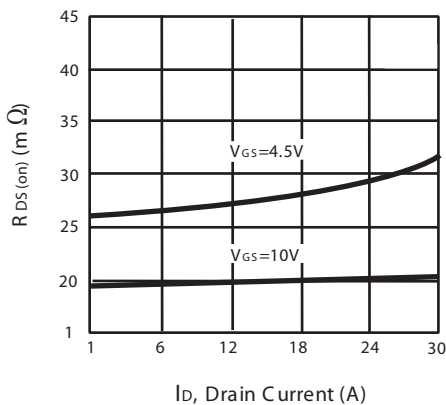

Figure 3. On-Resistance vs. Drain Current and Gate Voltage

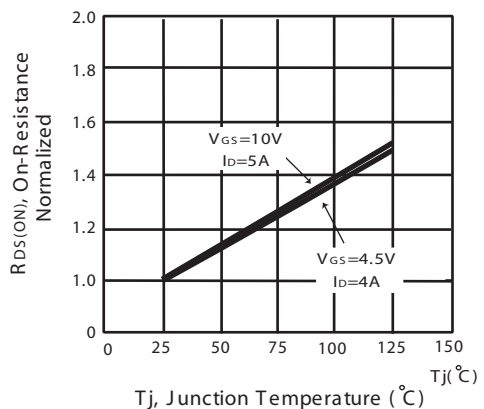

Figure 4. On-Resistance Variation with Drain Current and Temperature

STM8457

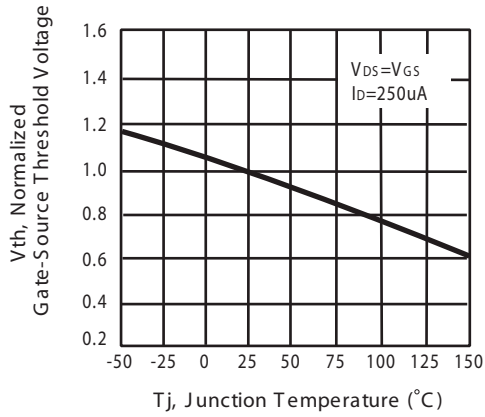

Figure 5. Gate Threshold Variation with Temperature

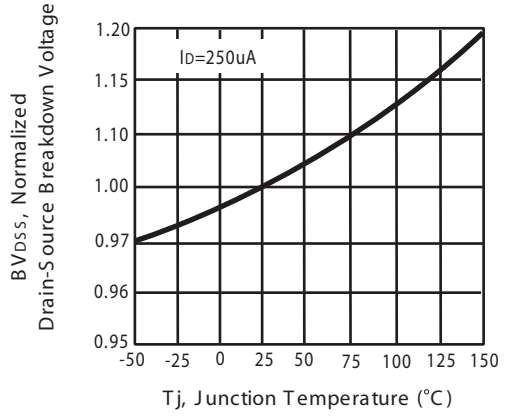

Figure 6. Breakdown Voltage Variation with Temperature

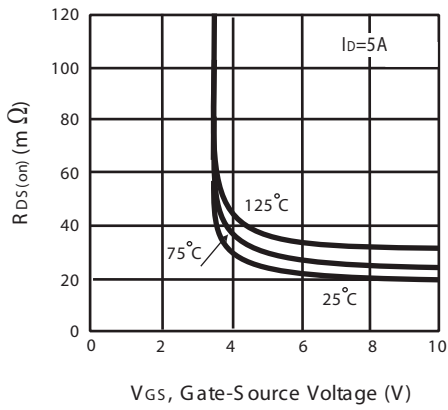

Figure 7. On-Resistance vs. Gate-Source Voltage

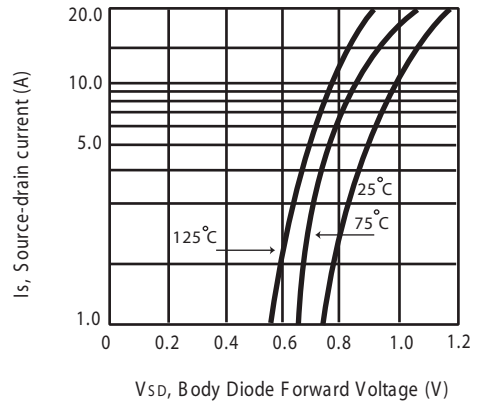

Figure 8. Body Diode Forward Voltage Variation with Source Current

STM8457

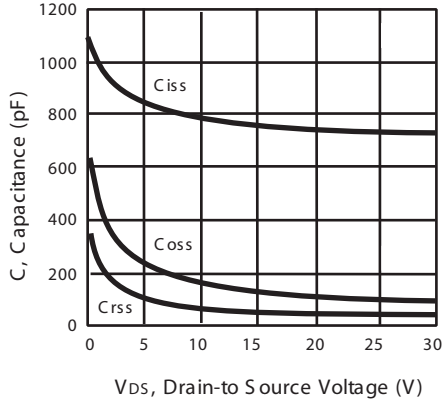

Figure 9. Capacitance

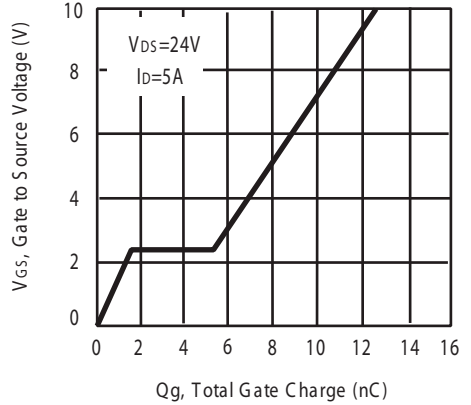

Figure 10. Gate Charge

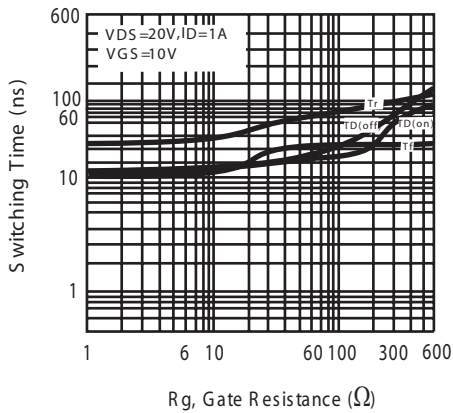

Figure 11. switching characteristics

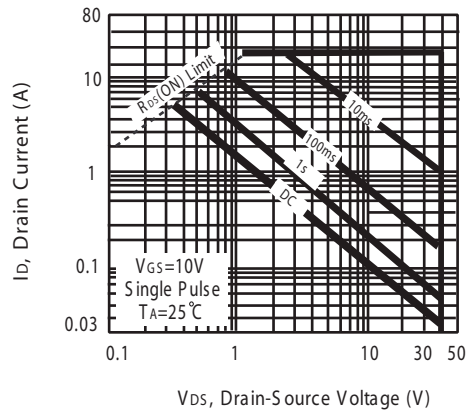
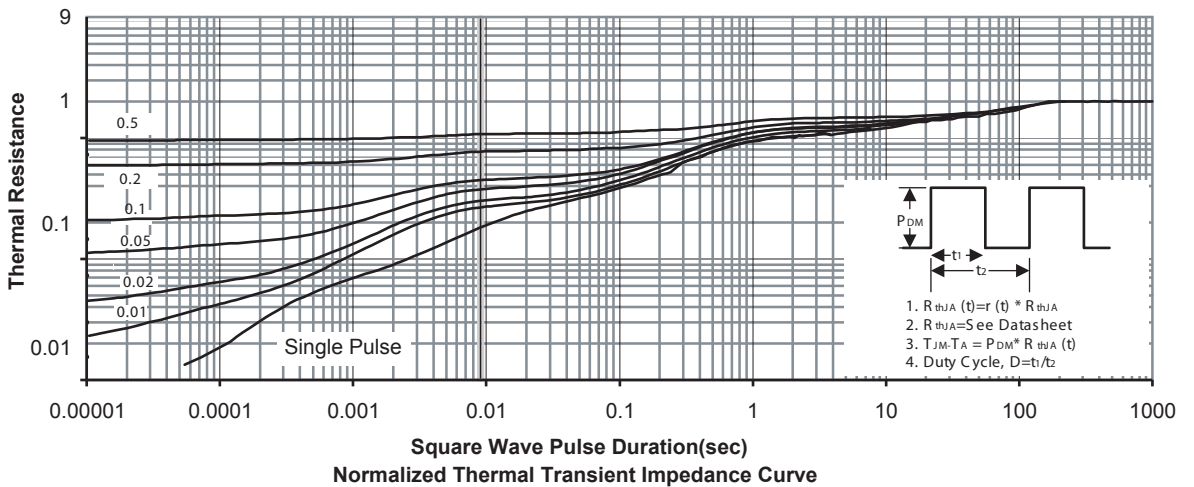

Figure 12. Maximum Safe Operating Area



STM8457

P-Channel

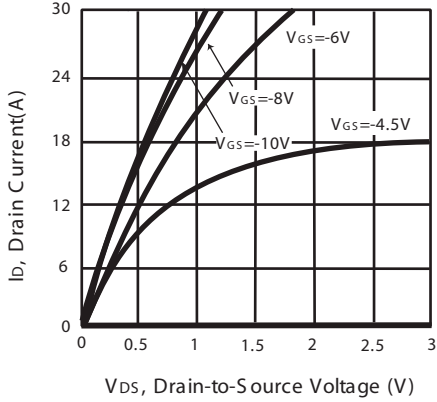

Figure 1. Output Characteristics

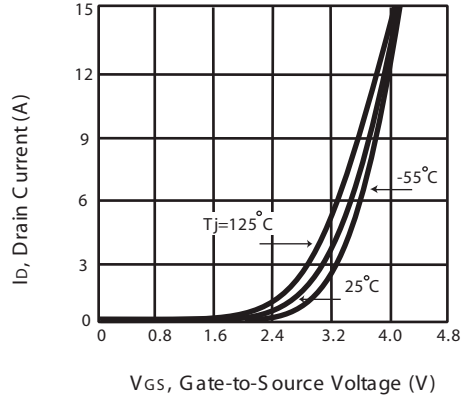

Figure 2. Transfer Characteristics

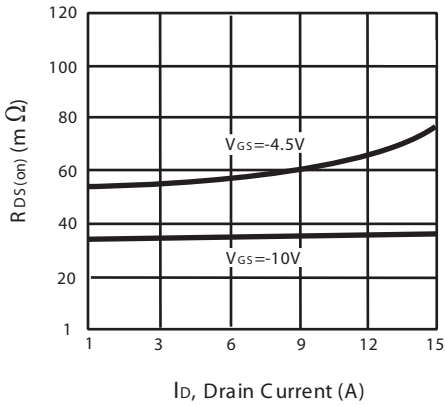

Figure 3. On-Resistance vs. Drain Current and Gate Voltage

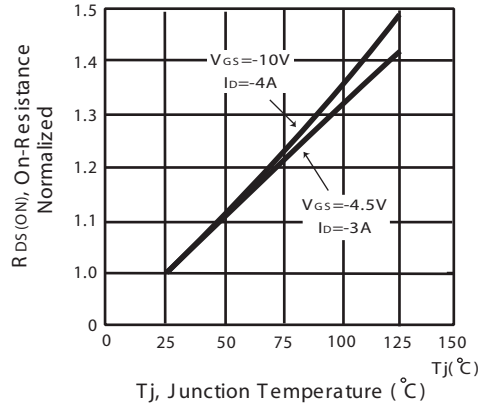

Figure 4. On-Resistance Variation with Drain Current and Temperature

STM8457

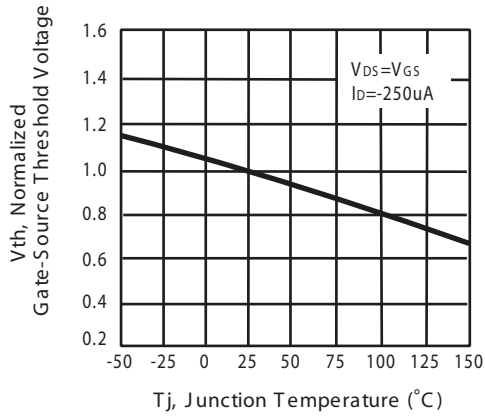

Figure 5. Gate Threshold Variation with Temperature

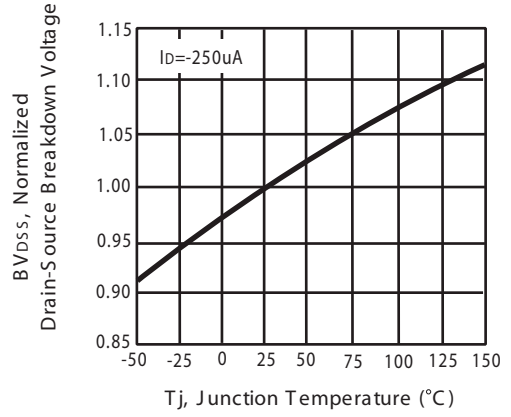

Figure 6. Breakdown Voltage Variation with Temperature

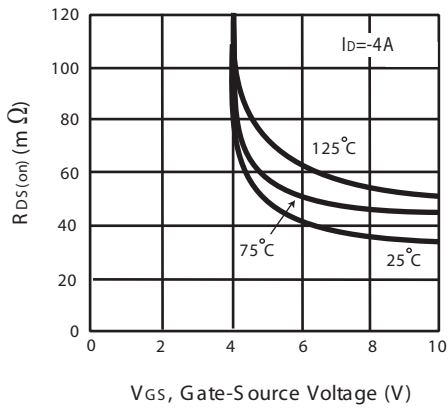

Figure 7. On-Resistance vs. Gate-Source Voltage

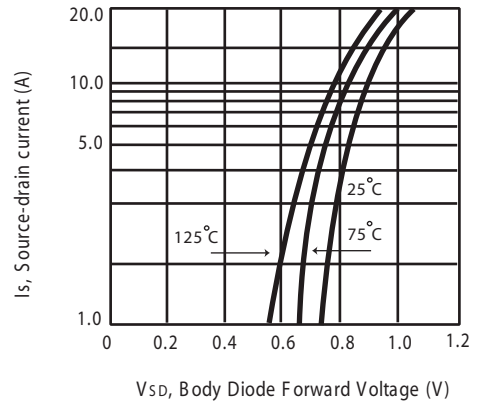

Figure 8. Body Diode Forward Voltage Variation with Source Current

STM8457

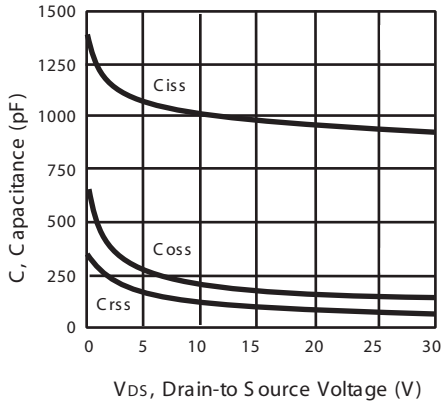

Figure 9. Capacitance

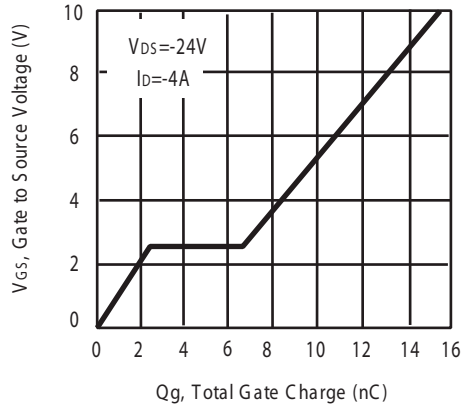

Figure 10. Gate Charge

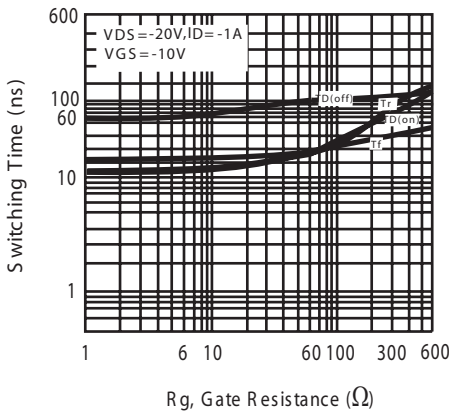

Figure 11. switching characteristics

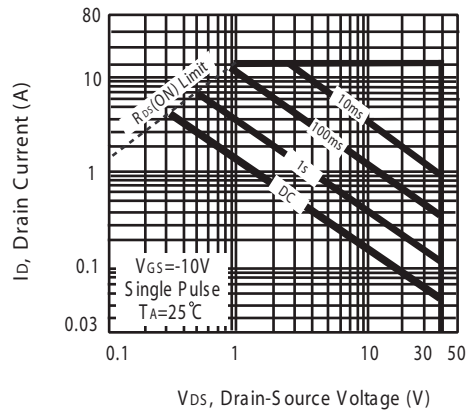
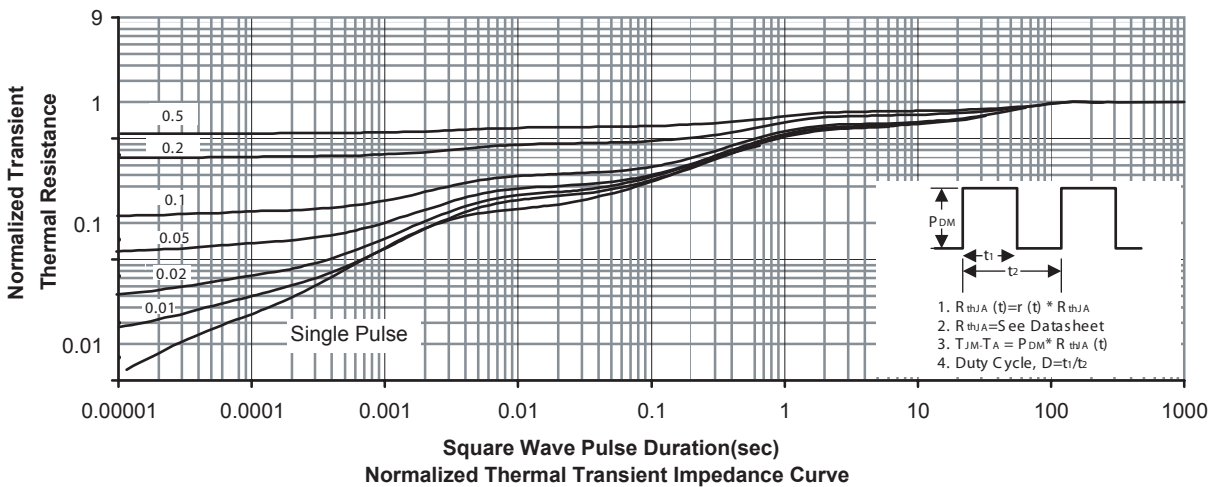

Figure 12. Maximum Safe Operating Area



STM8457

PACKAGE OUTLINE DIMENSIONS

SO-8

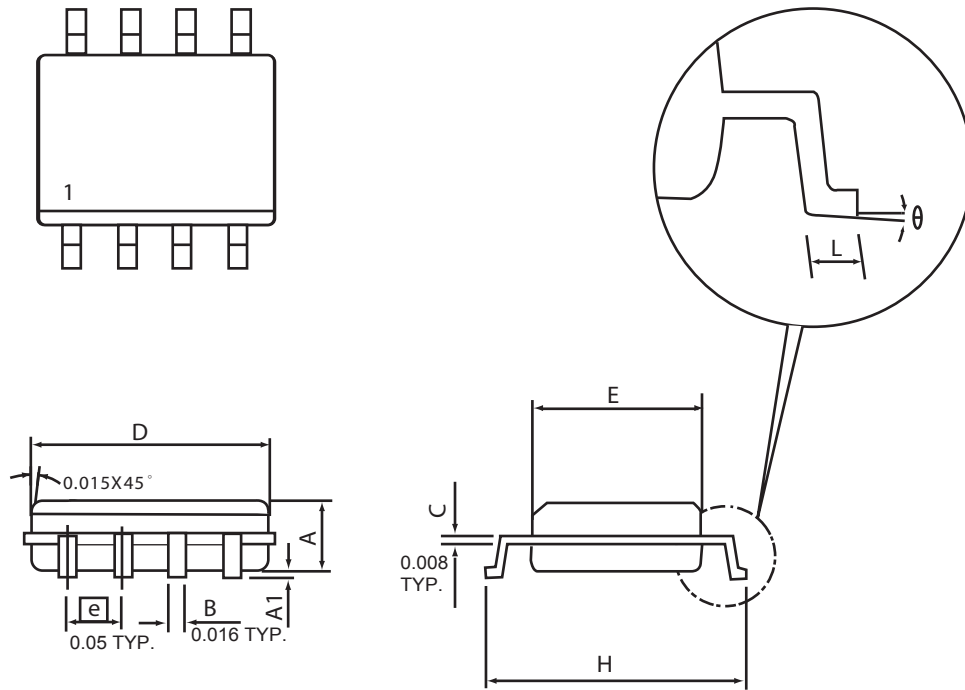

| SYMBOLS | MILLIMETERS | | INCHES | |
|----------|-------------|-----------|-----------|-----------|
| | MIN | MAX | MIN | MAX |
| A | 1.35 | 1.75 | 0.053 | 0.069 |
| A1 | 0.10 | 0.25 | 0.004 | 0.010 |
| D | 4.80 | 4.98 | 0.189 | 0.196 |
| E | 3.81 | 3.99 | 0.150 | 0.157 |
| H | 5.79 | 6.20 | 0.228 | 0.244 |
| L | 0.41 | 1.27 | 0.016 | 0.050 |
| θ | 0° | 8° | 0° | 8° |

STM8457

SO-8 Tape and Reel Data

SO-8 Carrier Tape

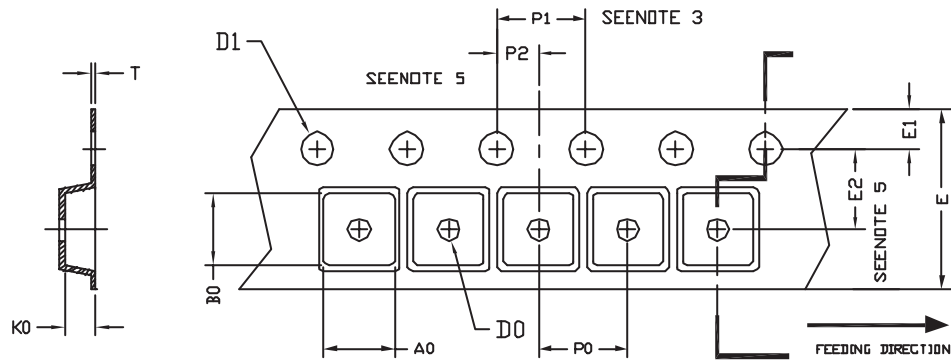

unit:mm

| PACKAGE | A0 | B0 | K0 | D0 | D1 | E | E1 | E2 | P0 | P1 | P2 | T |
|------------------|------|------|------|---------------------|------------------------------|-------------------|------|-------------------|-----|-----|-------------------|-------------------|
| SOP 8N 150mil | 6.40 | 5.20 | 2.10 | ϕ 1.5 (MIN) | ϕ 1.5 + 0.1 - 0.0 | 12.0 \pm 0.3 | 1.75 | 5.5 \pm 0.05 | 8.0 | 4.0 | 2.0 \pm 0.05 | 0.3 \pm 0.05 |

SO-8 Reel

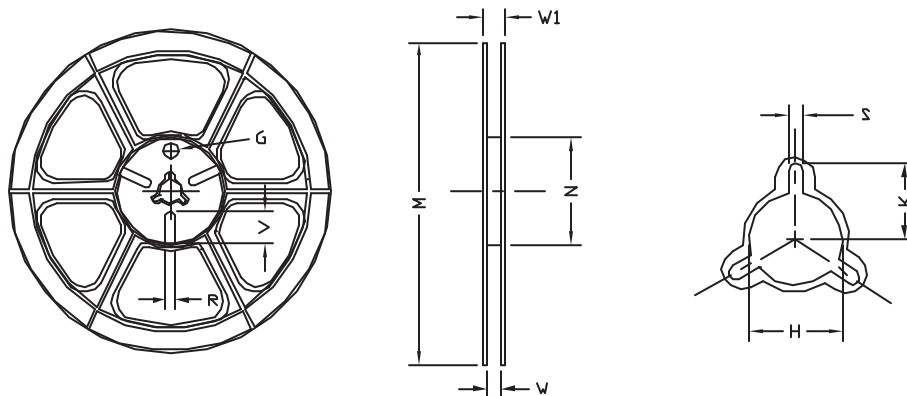

UNIT:mm

| TAPE SIZE | REEL SIZE | M | N | W | W1 | H | K | S | G | R | V |
|-----------|------------|----------------|-----------------|---------------|---------------|------------------------|-----|-------------------|-----|-----|-----|
| 12 mm | ϕ 330 | 330 \pm 1 | 62 \pm 1.5 | 12.4 + 0.2 | 16.8 - 0.4 | ϕ 12.75 + 0.15 | --- | 2.0 \pm 0.15 | --- | --- | --- |