

ChargePump™ High Current Charge Pump with Dual LDO for Backlight and Flash Applications

General Description

The AAT2846 is a highly integrated charge pump with dual linear regulators optimized for systems powered from lithium-ion/polymer batteries. The charge pump provides power for both white LED backlight and flash. Six backlight LEDs can be driven at up to 30mA each, while up to two flash LEDs can be driven at up to 600mA total. AnalogicTech's AS²Cwire™ (Advanced Simple Serial Control™) single-wire interface is used to enable, disable, and set the current to one of 32 levels for the backlight and one of 16 levels for the flash. An external resistor sets the maximum flash current. Backlight current matching is 1% for uniform display brightness, and flash current matching is 4% for uniform power dissipation.

The AAT2846 offers two high-performance low-noise MicroPower™ low dropout (LDO) linear regulators. Both regulators use individual enable inputs and each will supply up to 200mA load current. LDO ground pin current is only 80µA, making the AAT2846 ideal for battery-operated applications.

The AAT2846 is equipped with built-in short-circuit and over-temperature protection. The soft start circuitry prevents excessive inrush current at start-up and mode transitions.

The AAT2846 is available in a Pb-free TQFN44-28 package and operates over the -40°C to +85°C ambient temperature range.

Typical Application

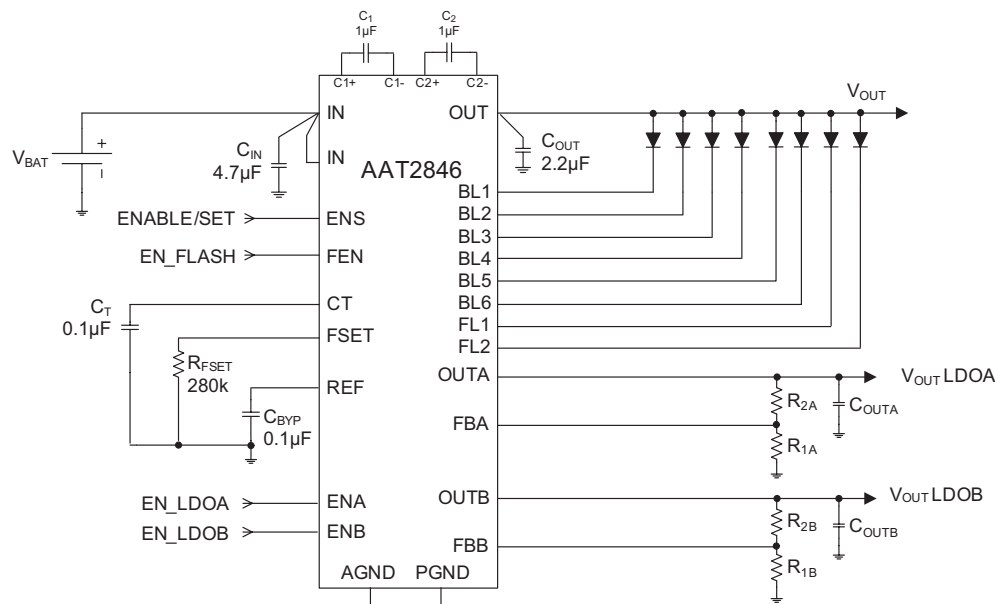

Features

- Input Voltage Range: 2.7V to 5.5V
- Tri-Mode Charge Pump:
 - Drives up to Six Backlight LEDs and Two Flash LEDs
 - 32 Programmable Backlight Current Settings Ranging from 95µA to 30mA
 - 16 Programmable Flash Current Settings
 - Maximum Flash LED Current Programmable using External Resistor
 - 2MHz Switching Frequency
- Two Linear Regulators:
 - 200mA Output Current
 - 200mV Dropout Voltage
 - Output Voltage Adjustable from 1.2V to V_{BATTERY}
 - Output Auto-Discharge for Fast Shutdown
 - Individual LDO Enable Inputs
- Built-In Thermal Protection
- Automatic Soft Start
- -40°C to +85°C Temperature Range
- TQFN44-28 Package

Applications

- Camera-Enabled Mobile Devices
- Digital Still Cameras
- Multimedia Mobile Phones

ChargePump™ High Current Charge Pump with Dual LDO for Backlight and Flash Applications
Pin Descriptions

Pin #	Symbol	Description
1	BL3	Backlight LED 3 current sink. BL3 controls the current through backlight LED 3. Connect the cathode of backlight LED 3 to BL3. If not used, connect BL3 to OUT.
2	BL2	Backlight LED 2 current sink. BL2 controls the current through backlight LED 2. Connect the cathode of backlight LED 2 to BL2. If not used, connect BL2 to OUT.
3	BL1	Backlight LED 1 current sink. BL1 controls the current through backlight LED 1. Connect the cathode of backlight LED 1 to BL1. If not used, connect BL1 to OUT.
4	AGND	Analog ground. Connect AGND to PGND at a single point as close to the AAT2846 as possible.
5	CT	Flash timer control capacitor input. Connect a capacitor from CT to AGND to set the flash timer. A 100nF capacitor sets the timer to 1 second.
6	REF	Reference output. Bypass REF to AGND with a 0.1μF or larger ceramic capacitor.
7	FBB	Feedback input for LDO B. FBB measures the output voltage of LDO B. Connect a resistive voltage divider from the output of LDO B to FBB. FBB feedback regulation voltage is 1.2V.
8	OUTB	LDO B regulated voltage output. OUTB is the voltage output of LDO B. Bypass OUTB to AGND with a 2.2μF or larger ceramic capacitor as close to the AAT2846 as possible.
9, 18	IN	Power input. Connect IN to the input source voltage. Bypass IN to PGND with a 4.7μF or larger ceramic capacitor as close to the AAT2846 as possible.
10	FBA	Feedback input for LDO A. FBA measures the output voltage of LDO A. Connect a resistive voltage divider from the output of LDO A to FBA. FBA feedback regulation voltage is 1.2V.
11	OUTA	LDO A regulated voltage output. OUTA is the voltage output of LDO A. Bypass OUTA to AGND with a 2.2μF or larger ceramic capacitor as close to the AAT2846 as possible.
12	C1-	Negative node of charge pump capacitor 1. Connect the 1μF charge pump capacitor 1 from C1+ to C1-.
13	C1+	Positive node of charge pump capacitor 1. Connect the 1μF charge pump capacitor 1 from C1+ to C1-.
14	OUT	Charge pump output; supplies current to the backlight and flash LEDs. Connect the backlight and flash LED anodes to OUT. Bypass OUT to PGND with a 2.2μF or larger ceramic capacitor as close to the AAT2846 as possible.
15	ENB	LDO B enable input. ENB turns on or off low dropout regulator B (LDO B). Drive ENB high to turn on LDO B; drive it low to turn it off.
16	C2+	Positive node of charge pump capacitor 2. Connect the 1μF charge pump capacitor 2 from C2+ to C2-.
17	C2-	Negative node of charge pump capacitor 2. Connect the 1μF charge pump capacitor 2 from C2+ to C2-.
19	PGND	Power ground. Connect AGND to PGND at a single point as close to the AAT2846 as possible.
20	ENS	Flash and backlight enable and serial control input. ENS turns on/off both the flash and backlight and is the AS ² Cwire input to serially control the backlight and movie-mode flash LED brightness.
21	FL2	Flash LED 2 current sink. FL2 controls the current through flash LED 2. Connect the cathode of flash LED 2 to FL2. If not used, connect FL2 to OUT.
22	FL1	Flash LED 1 current sink. FL1 controls the current through flash LED 1. Connect the cathode of flash LED 1 to FL1. If not used, connect FL1 to OUT.
23	FEN	Flash enable input. FEN is the on/off control for the flash LEDs. Drive FEN high to drive the maximum flash current, set by RFSET, through the flash LEDs.
24	FSET	Flash current setting input. A 280kΩ resistor from FSET to AGND sets the maximum flash LED current.
25	BL6	Backlight LED 6 current sink. BL6 controls the current through backlight LED 6. Connect the cathode of backlight LED 6 to BL6. If not used, connect BL6 to OUT.
26	BL5	Backlight LED 5 current sink. BL5 controls the current through backlight LED 5. Connect the cathode of backlight LED 5 to BL5. If not used, connect BL5 to OUT.
27	ENA	LDO A enable input. ENA turns on or off low dropout regulator A (LDO A). Drive ENA high to turn on LDO A; drive low to turn it off.
28	BL4	Backlight LED 4 current sink. BL4 controls the current through backlight LED 4. Connect the cathode of backlight LED 4 to BL4. If not used, connect BL4 to OUT.
EP		Exposed paddle (bottom); connect to ground as closely as possible to the device.

Pin Configuration

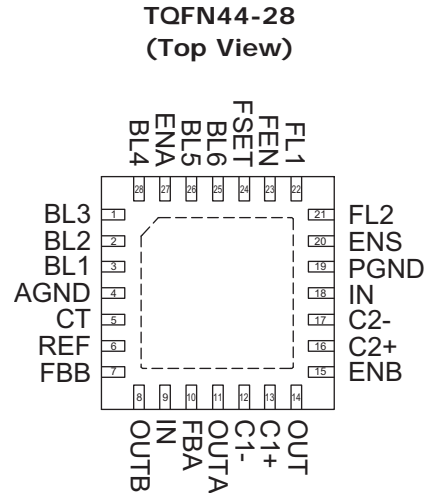

Absolute Maximum Ratings¹

Symbol	Description	Value	Units
	IN, OUT, FL1, FL2, BL1, BL2, BL3, BL4, BL5, BL6 Voltage to PGND	-0.3 to 6.0	V
	FSET, CT, REF, FBB, OUTA, FBA, OUTB, ENA, ENB, FEN, ENS	-0.3 to $V_{IN} + 0.3$	V
	C1+, C1-, C2+, C2- Voltage to PGND		V
	PGND Voltage to AGND	-0.3 to 0.3	V
T_J	Operating Junction Temperature Range	-40 to 150	°C
T_{LEAD}	Maximum Soldering Temperature (at leads, 10 sec)	300	°C

Thermal Information²

Symbol	Description	Value	Units
P_D	Maximum Power Dissipation ³	2	W
θ_{JA}	Maximum Thermal Resistance	50	°C/W

1. Stresses above those listed in Absolute Maximum Ratings may cause permanent damage to the device. Functional operation at conditions other than the operating conditions specified is not implied. Only one Absolute Maximum Rating should be applied at any one time.
 2. Mounted on a FR4 circuit board.
 3. Derate 6.25mW/°C above 25°C ambient temperature.

ChargePump™ High Current Charge Pump with Dual LDO for Backlight and Flash Applications
Electrical Characteristics¹

$V_{IN} = 3.6V$; $C_{IN} = 4.7\mu F$; $C_{OUT} = 2.2\mu F$; $C_1 = C_2 = 1\mu F$; $R_{FSET} = 280k\Omega$; $T_A = -40^\circ C$ to $+85^\circ C$, unless otherwise noted. Typical values are $T_A = 25^\circ C$.

Symbol	Description	Conditions	Min	Typ	Max	Units
V_{IN}	IN Operating Voltage Range		2.7		5.5	V
$I_{IN(Q)}$	IN Operating Current	1X Mode, $3.0V \leq V_{IN} \leq 5.5V$, Active, No Load; ENL = AGND, FEN = ENS = IN			1	mA
		1.5X Mode, $3.0V \leq V_{IN} \leq 5.5V$, Active, No Load; ENL = AGND, FEN = ENS = IN			4	
		2X Mode, $3.0V \leq V_{IN} \leq 5.5V$, Active, No Load; ENL = AGND, FEN = ENS = IN			5	
$I_{IN(SHDN)}$	IN Shutdown Current	ENA = ENB = ENS = FEN = AGND			1.0	μA
T_{SD}	Over-Temperature Shutdown Threshold			140		$^\circ C$
$T_{SD(HYS)}$	Over-Temperature Shutdown Hysteresis			15		$^\circ C$
Charge Pump Section						
I_{OUT}	OUT Maximum Output Current			600		mA
$V_{IN(TH_H)}$	Charge Pump Mode Hysteresis	Address 0, Data 1		500		mV
f_{OSC}	Charge Pump Oscillator Frequency	$T_A = 25^\circ C$		2		MHz
BL1-BL6 Backlight LED Outputs						
$I_{BL(MAX)}$	BL1-BL6 Maximum Current	Address 0, Data 1; $V_{IN} - V_F = 1.5V$	18	20	22	mA
		Address 12, Data 2; $V_{IN} - V_F = 1.5V$		30		
$\Delta I_{(BL)}$	BL1-BL6 Current Matching ²	Address 0, Data 1; $V_{IN} - V_F = 1.5V$			1.0	%
	BL1-BL6 Charge Pump Mode Transition Threshold			150		mV
FL1-FL2 Flash LED Outputs						
$I_{FL(MAX)}$	FL1-FL2 Maximum Current	Address 4, Data 1; $V_{IN} - V_F = 1.5V$	270	300	330	mA
$\Delta I_{(FL)}$	FL1-FL2 Current Matching ²	Address 4, Data 1; $V_{IN} - V_F = 1.5V$			4.0	%
$V_{FL(TH)}$	FL1-FL2 Charge Pump Mode Transition Threshold			300		mV
ENS, FEN Logic Control						
$V_{ENS(L)}$	ENS, FEN Input Low Threshold				0.4	V
$V_{ENS(H)}$	ENS, FEN Input High Threshold		1.4			V
I_{ENS}, I_{FEN}	ENS, FEN Input Leakage Current	V_{ENS} or $V_{FEN} = V_{IN} = 5V$	-1.0		1.0	μA
$t_{ENS(LOW)}$	ENS, FEN Serial Interface Low Time	$V_{IN} \geq 3.3V$	0.3		75	μs
$t_{ENS(HI_MIN)}, t_{ENS(HI_MIN)}$	ENS, FEN Serial Interface Minimum High Time			50		ns
$t_{ENS(HI_MAX)}, t_{ENS(HI_MAX)}$	ENS, FEN Serial Interface Maximum High Time	$V_{IN} \geq 3.3V$			75	μs
$t_{ENS(OFF)}, t_{FEN(OFF)}$	ENS, FEN Off Timeout				500	μs
$t_{ENS(LAT)}, t_{FEN(LAT)}$	ENS, FEN Serial Interface Latch Timeout				500	μs

1. The AAT2846 is guaranteed to meet performance specifications over the $-40^\circ C$ to $+85^\circ C$ operating temperature range and is assured by design, characterization, and correlation with statistical process controls.

2. Current matching is defined as the deviation of any sink current from the average of all active channels.

ChargePump™ High Current Charge Pump with Dual LDO for Backlight and Flash Applications
Electrical Characteristics¹

$V_{IN} = 3.6V$; $C_{IN} = 4.7\mu F$; $C_{OUT} = 2.2\mu F$; $C_1 = C_2 = 1\mu F$; $R_{FSET} = 280k\Omega$; $T_A = -40^\circ C$ to $+85^\circ C$, unless otherwise noted. Typical values are $T_A = 25^\circ C$.

Symbol	Description	Conditions	Min	Typ	Max	Units
Linear Regulators						
V_{FBA}, V_{FBB}	Feedback Voltage Tolerance	$I_{OUT} = 1mA$ to $200mA$	1.17	1.2	1.23	V
		$ENA = ENB = IN, ENS = AGND$			200	
$I_{OUTA(MAX)}, I_{OUTB(MAX)}$	OUTA, OUTB Maximum Load Current		200			mA
$V_{OUTA(DO)}, V_{OUTB(DO)}$	OUTA, OUTB Dropout Voltage	$I_{OUT} = 150mA$		150	300	mV
$PSRR_A, PSRR_B$	OUTA, OUTB Power Supply Rejection Ratio	$I_{OUT} = 10mA, C_{REF} = 10nF, 1kHz$		50		dB
$V_{EN-(L)}$	ENA, ENB Voltage Low Threshold				0.4	V
$V_{EN-(H)}$	ENA, ENB Voltage High Threshold		1.4			V
$t_{EN-(DLY)}$	ENA, ENB Enable Delay	REF = Open		15		μs

1. The AAT2846 is guaranteed to meet performance specifications over the $-40^\circ C$ to $+85^\circ C$ operating temperature range and is assured by design, characterization, and correlation with statistical process controls.

Typical Characteristics

Backlight Efficiency vs. Input Voltage

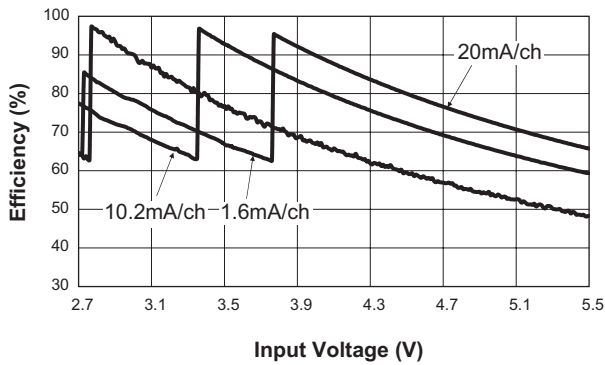

Flash Efficiency vs. Input Voltage

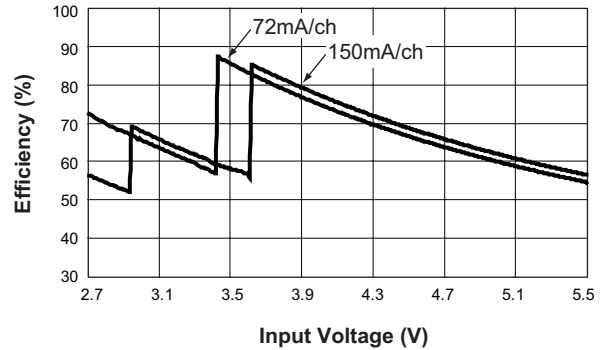

**Backlight Current Matching vs. Temperature
(20mA/ch; Data 1)**

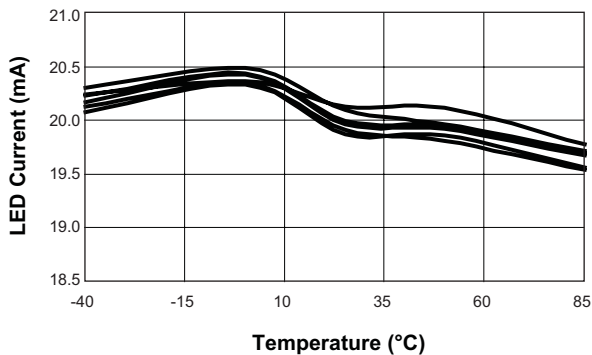

**Flash Current Matching vs. Temperature
(150mA/Ch; Data 6)**

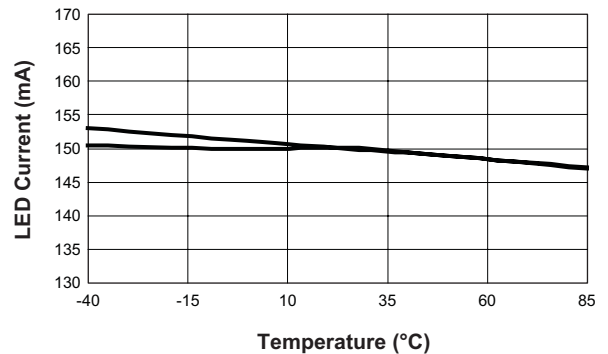

**Turn On to 1X Mode Backlight
(30mA/ch; Data 1; V_{IN} = 4.2V)**

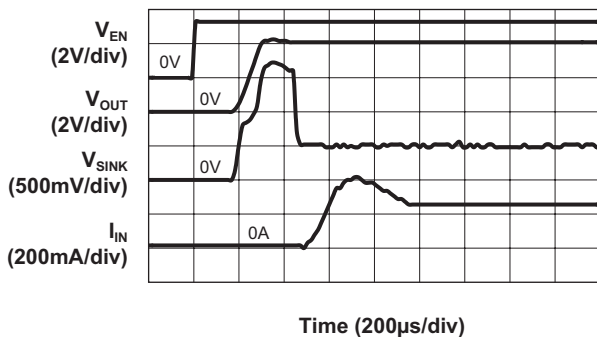

**Turn On to 1.5X Mode Backlight
(30mA/ch; Data 1; V_{IN} = 3.4V)**

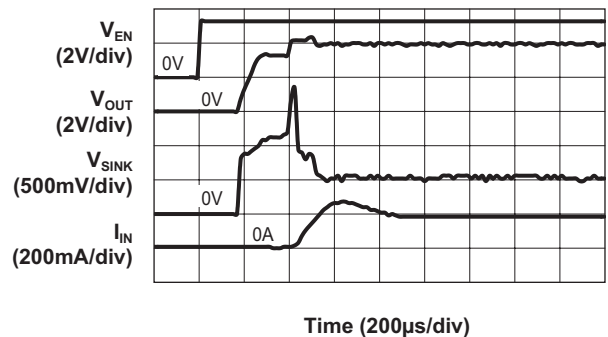

Typical Characteristics

Turn On to 2X Mode Backlight
(30mA/ch; Data 1; $V_{IN} = 2.7V$)

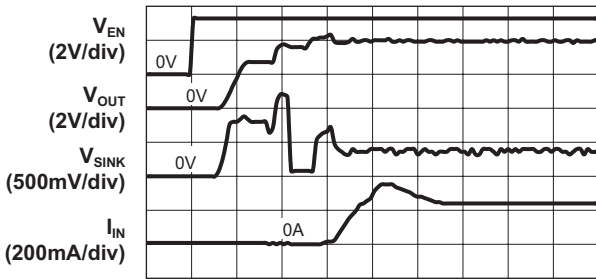

Time (200µs/div)

Turn Off from 1.5X Mode Backlight
(30mA/ch; Data 1)

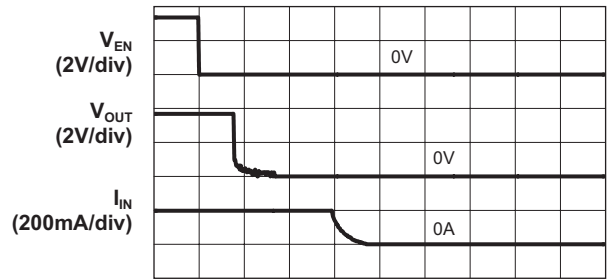

Time (100µs/div)

BENS, FENS High Threshold Voltage vs. Input Voltage

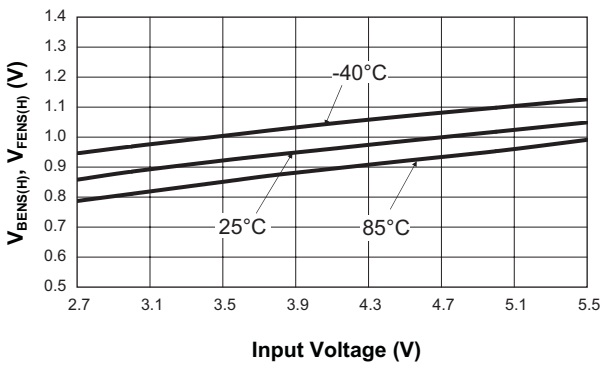

BENS, FENS Low Threshold Voltage vs. Input Voltage

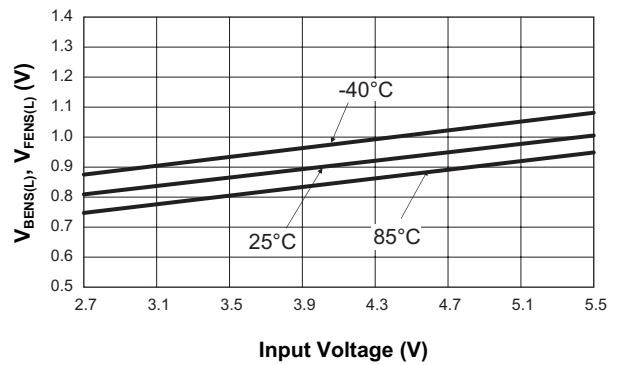

BENS, FENS Latch Timeout vs. Input Voltage

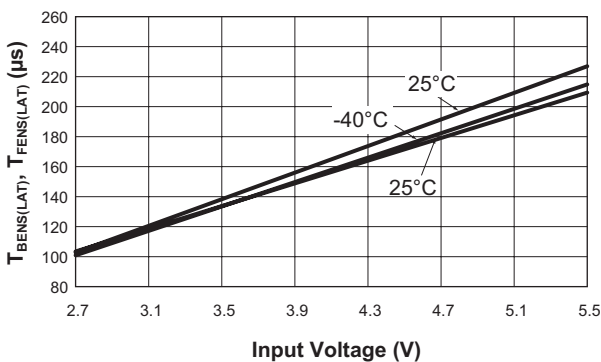

BENS, FENS Off Timeout vs. Input Voltage

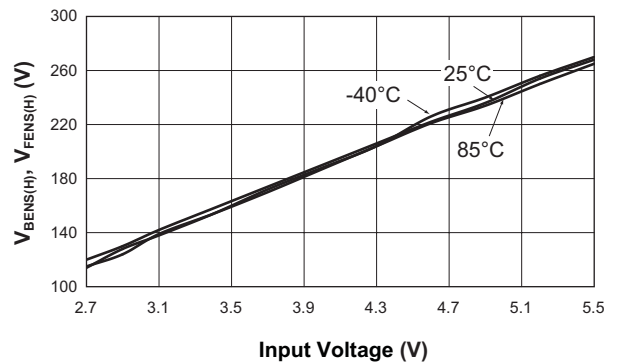

Typical Characteristics

LDOs A and B Turn On Characteristic

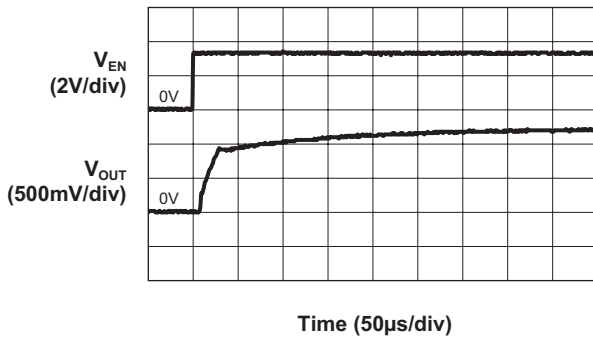

LDOs A and B Load Regulation

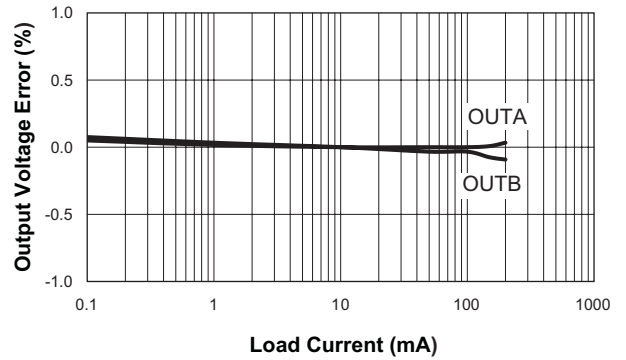

LDOs A and B Output Voltage vs. Temperature

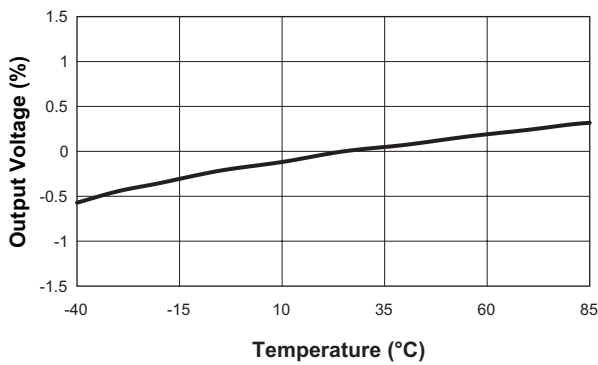

LDOs A and B Dropout Characteristics

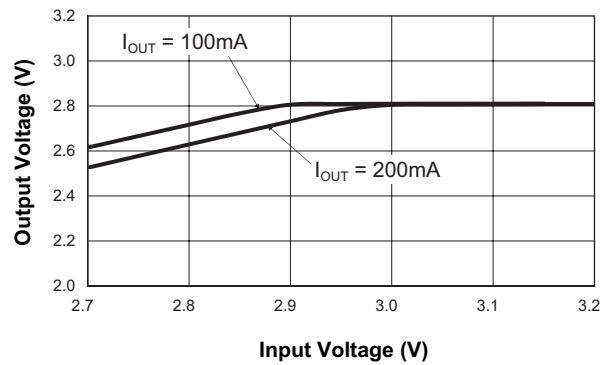

LDOs A and B Line Transient Response (10mA Load)

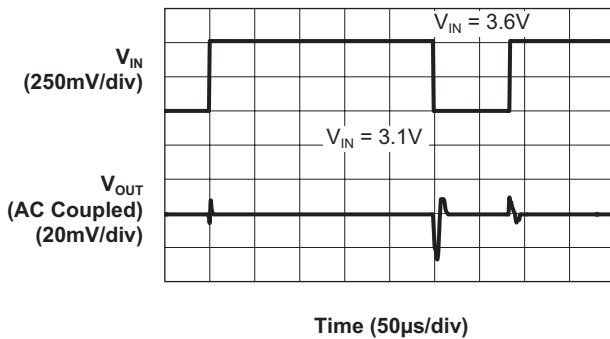

LDOs A and B Load Transient Response (10mA to 200mA Load Step)

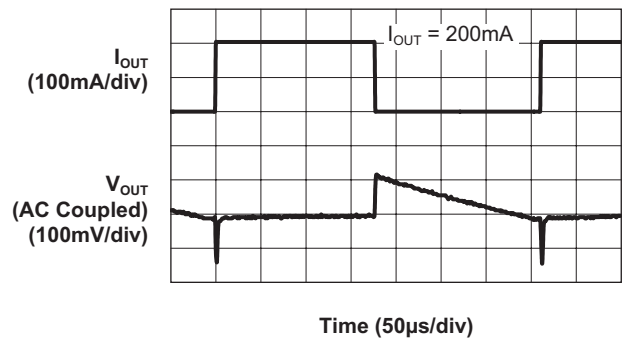

Functional Block Diagram

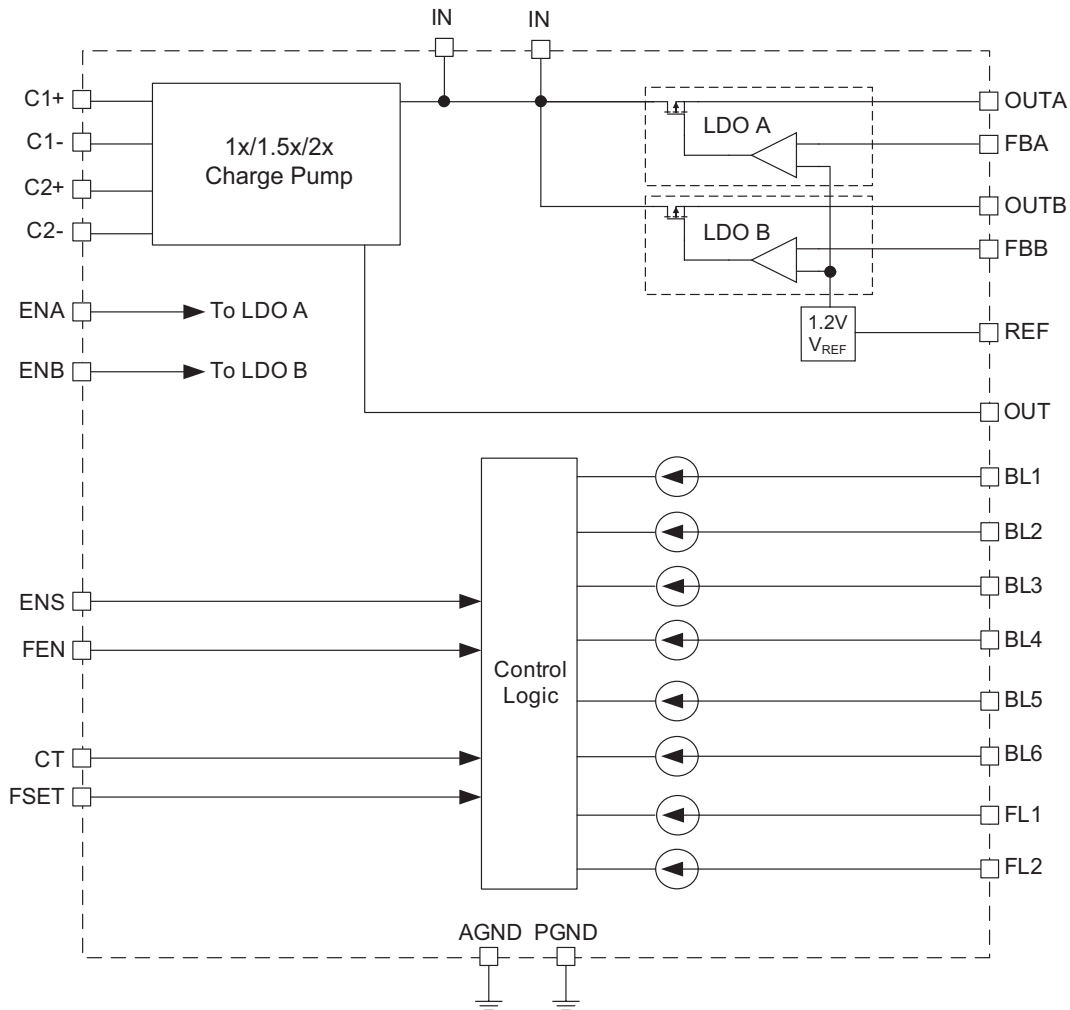

Functional Description

The AAT2846 is a highly integrated backlight and flash LED driver with two LDO linear regulators. The charge pump LED driver drives backlight and flash LEDs from a 2.7V to 5.5V input voltage. The LDO regulators are operated from the same input voltage range and produce regulated output voltages as low as 1.2V.

LED Drivers

The LEDs are driven from an internal charge pump that, depending on the battery voltage and LED forward voltage, drives LEDs directly from the supply voltage (1X or bypass mode) or steps up the supply voltage by a factor of 1.5 (1.5X mode) or 2 (2X mode). The charge pump requires only two tiny 1 μ F ceramic capacitors, providing a

more compact solution than typical inductor-based step-up converter solutions. Each individual LED is driven by a current sink to AGND, allowing individual current control with high accuracy over a wide range of input voltages and LED forward voltages while maintaining high efficiency.

The charge pump is controlled by the voltage across the LED current sinks. When any one of the active current sinks begins to dropout, the charge pump goes to the next higher mode (from 1X to 1.5X or from 1.5X to 2X mode) to maintain sufficient LED voltage for constant LED current. The AAT2846 continuously monitors the LED forward voltages and uses the input voltage to determine when to reduce the charge pump mode for better efficiency. There is also a 500mV mode-transition hysteresis that prevents the charge pump from oscillating between charge pump modes.

ChargePump™ High Current Charge Pump with Dual LDO for Backlight and Flash Applications

The backlight and flash LED current levels are dynamically controllable by the AS²Cwire single-wire interface. The backlight section has multiple current level scales and the maximum current level is fixed at 20mA or 30mA, depending on the scale chosen through programming. The flash section maximum current level is user programmable by an external set resistor. The maximum flash current that can be supported by the device is 300mA/channel, or 600mA total. This corresponds to a 280K set resistor value.

For maximum LED current lower than 300mA, use a programming resistor greater than 280kΩ up to 1MΩ. Calculate the flash programming resistor value using the equation:

$$R_{FSET} = \frac{280k \cdot 300mA}{I_{FMAX}} \Omega$$

where I_{FMAX} is the maximum flash LED current in mA.

If any one of the backlight or flash current sinks is not used, connect that current sink to OUT. The current controller monitors the sink voltage and, if it is connected to OUT, then the controller determines that the current sink is not used or that the LED is shorted. In either case, the controller turns off the affected current sink.

AS²Cwire Serial Interface

The AAT2846 is dynamically programmable by the AS²Cwire single-wire interface. AS²Cwire records rising edges detected at the ENS pin to address and load the data registers. AS²Cwire latches data or address after the ENS input has been held high for time T_{LAT} (500μs). Address or data is differentiated by the number of ENS rising edges. Since the data registers are 4 bits each, the differentiating number of pulses is 24 or 16, so that Address 0 is identified by 17 rising edges, Address 1 by 18 rising edges, Address 2 by 19 rising edges, etc. Data is set to any number of rising edges between 1 and 16. A typical write protocol is a burst of ENS rising edges identifying a particular address, followed by a pause with ENS held high for the T_{LAT} timeout period, then a burst of rising edges signifying data, and another T_{LAT} timeout after the data has been sent. Once an address is set, multiple writes to that address are allowed since the address is not reset after each write. Address edges are needed when changing the address, or writing to an address other than the default after shutdown. Address 0 is the default address after shutdown. If the part is enabled with only data edges and no address, then Address 0 will be programmed and backlight channels BL1-BL6 will turn-on according to the number of data edges applied.

When ENS is held low for a time greater than T_{OFF} (500μs), the AAT2846 enters shutdown mode and draws less than 1μA of current from IN. At shutdown, the data and address registers are reset to 0.

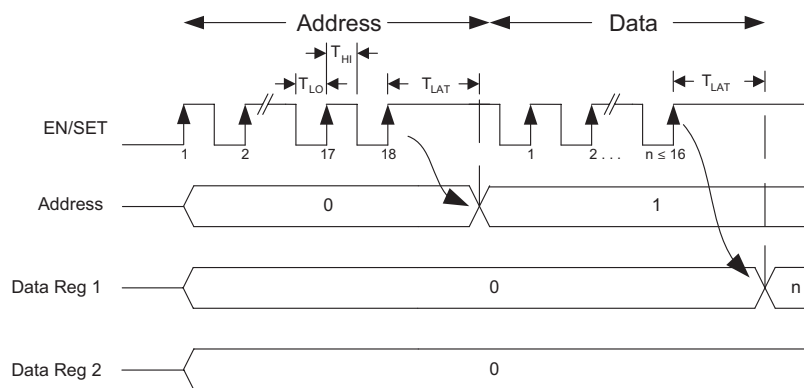

Figure 1: AS²Cwire Serial Interface Timing.

AS²Cwire Serial Interface Addressing

Address	ENS Rising Edges	Function
0	17	Backlight Current BL1-BL6
1	18	Main Backlight Current BL1-BL5
2	19	Sub Backlight Current BL6
3	20	Low Current Backlight
4	21	Flash Current FL1, FL2
5	22	Independent Flash On/Off Control
12	29	Maximum Backlight Current (Main and Sub)
15	32	Backlight Independent Control
Sub-2	19	BL3-BL6 On/Off Control
Sub-3	20	BL1/BL2 On/Off Control

Table 1: AS²Cwire Serial Interface Addressing.

Backlight Current Control (Address 0-3)

Use Addresses 0-3 to program all six backlight LED channels. All six backlight channels are programmed to the same current level by writing Address 0 followed by any Data between 1 and 16. To program only the main channels BL1 through BL5, use Address 1. Similarly, use Address 2 to independently program subchannel BL6 only.

Data	30mA Max (mA)	20mA Max (mA)
1	30.0	20.0
2	27.9	19.0
3	26.1	17.8
4	24.2	16.5
5	21.0	14.3
6	19.2	13.0
7	17.3	11.8
8	15.0	10.2
9	12.7	8.5
10	10.9	7.3
11	8.1	5.4
12	6.2	4.1
13	4.4	2.9
14	3.5	2.2
15	2.6	1.6
16	0	0

Table 2: Data Code for Backlight Current Level, Address 0-2.

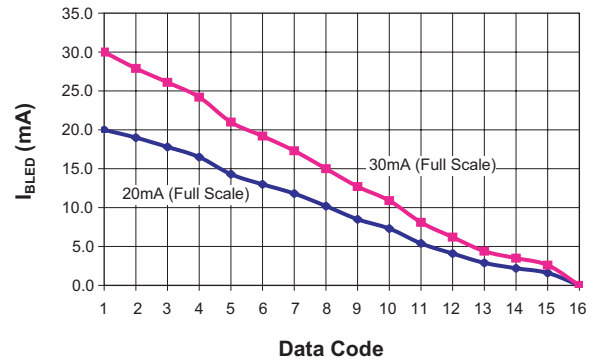

Figure 2: Data Code for Address 0-2 vs. Backlight Current Level.

The AAT2846 incorporates additional circuitry that optimizes performance for exceptionally low backlight current settings. A separate address is used to activate this circuitry. To program the low current settings with improved performance and efficiency, write to Address 3. Unlike Addresses 0-3, which have current level settings according to Table 2 and Figure 2, Address 3 possesses a separate set of current levels described by the Low Current Backlight settings found in Table 3.

Data	Main Current On	Sub Current On	Current (μA)
1	No	No	0
2	No	No	0
3	No	No	0
4	No	No	0
5	No	Yes	95
6	No	Yes	500
7	No	Yes	950
8	No	Yes	1900
9	Yes	No	95
10	Yes	No	500
11	Yes	No	950
12	Yes	No	1900
13	Yes	Yes	95
14	Yes	Yes	500
15	Yes	Yes	950
16	Yes	Yes	1900

Table 3: Data Code for Low-Level Backlight Current, Address 3, FS = 20mA range.

ChargePump™ High Current Charge Pump with Dual LDO for Backlight and Flash Applications

Flash Current FL1, FL2 (Address 4)

The current level for the flash channels FL1 and FL2 is programmed by Address 4. Data 1 enables the maximum current level. The maximum current level is determined by the value of R_{FSET} . Table 4 and Figure 3 illustrate the additional flash current levels that are available.

Data	Flash LED Current (% of Maximum)
1	100
2	87
3	77
4	66
5	58
6	50
7	44
8	39
9	35
10	30
11	27
12	24
13	20
14	17
15	16
16	14

Table 4: Data Code for the Flash Current Control, Address 4.

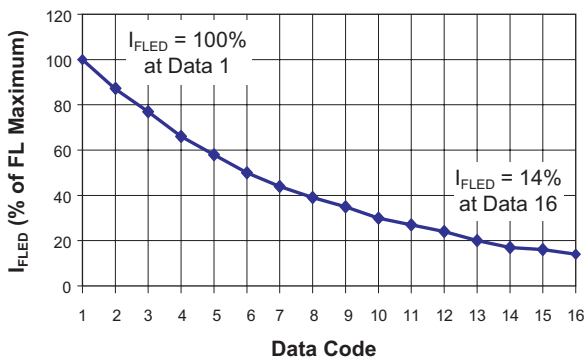

Figure 3: Data Code for Address 4 vs. Percentage of Flash Current Level.

Independent Flash ON/OFF Control (Address 5)

Use Address 5 to program which flash channels are active. By default, both flash channels are OFF at start-up. After writing to Address 4 to program the desired

flash channel current level, write to Address 5 to enable a single channel or both channels according to Table 5.

Data	FL1	FL2
1	Off	Off
2	Off	On
3	On	Off
4	On	On

Table 5: Output Enable Control, Address 5.

Writing to Address 5 enables the flash channels indefinitely. FL1 and FL2 will remain ON until Address 5 is re-programmed to OFF, ENS is strobed low to shutdown the device, or the flash safety timer times out after FEN has been strobed high. The flash safety timer is always activated when FEN is taken high. The Address 5 data setting is always reset to Data 1 when the flash timer expires or when FEN is strobed low.

Maximum Backlight Current (Address 12)

There are two separate current level scales that apply to Addresses 0-2: 20mA and 30mA. According to the Maximum Backlight Current setting at Address 12, only one of the two scales can be active at any given time and never both. By default, the 20mA scale is active on startup. To change to the 30mA scale, or go back to the 20mA scale, write to Address 12.

Since only one of the scales can be active at any given time, the 20mA and 30mA scales cannot be mixed between main and sub. When setting Address 12 to the 30mA scale, only current levels from that scale can be mixed between main and sub.

Data	Maximum Current
1	20mA
2	30mA

Table 6: Data Code for the Maximum Current Settings, Address 12.

Backlight Independent Channel Control (Address 15)

The AAT2846 has a unique independent channel control mode whereby individual backlight LED channels can be enabled and disabled to form a custom arrangement of active channels.

ChargePump™ High Current Charge Pump with Dual LDO for Backlight and Flash Applications

To enable independent channel control mode, write Data 8 to Address 15. To exit individual mode control, the AAT2846 state machine can be reset by strobing ENS low and holding ENS low longer than the AS²Cwire's t_{OFF} latch time.

Data	Individual Backlight Control
8	On

Table 7: Data Code for Independent Backlight Control, Address 15.

With independent channel control mode enabled, Addresses 2 and 3 are re-mapped according to Tables 8 and 9. As indicated by the possible settings listed in the tables, any combination of backlighting channels can be enabled and disabled.

Because Addresses 2 and 3 are re-mapped when independent channel control mode is enabled, the functions originally assigned to Addresses 2 and 3 are no longer available.

It is also important to note that Address 0 is disabled when independent channel control mode is enabled. Additionally, Address 3 is disabled and the very low current settings cannot be used in this mode. Other addresses are unmodified by this mode so that the flash features can still be operated and the 30mA backlight scale can still be used.

The LDO enables are always independent of AS²Cwire programming.

Flash LED Current Control

The flash LEDs are driven through current sinks FL1 and FL2. There are two ways to drive the flash LEDs: either through the AS²Cwire serial interface or through the flash enable input, FEN. The AAT2846 also includes an adjustable safety timer to turn off the flash in the event of a controller fault to prevent overstressing the flash LEDs.

Flash/Movie Mode Operation

The flash LED current level is set via the serial interface according to a logarithmic scale where each code is 1.2dB lower than the previous code as a percentage of the maximum current set by an external resistor, R_{FSET} from FSET to AGND. Flash LED current is set between

14% and 100% of the maximum current for both channels through Address 4. For lower current applications such as torch, flashlight, or movie light, write to Address 5 to enable only FL1 or only FL2. For higher LED current, the flash channels can be connected in parallel to drive the sum of the two channel currents into a single LED.

Data	BL6	BL5	BL4	BL3
1	Off	Off	Off	Off
2	Off	Off	Off	On
3	Off	Off	On	Off
4	Off	Off	On	On
5	Off	On	Off	Off
6	Off	On	Off	On
7	Off	On	On	Off
8	Off	On	On	On
9	On	Off	Off	Off
10	On	Off	Off	On
11	On	Off	On	Off
12	On	Off	On	On
13	On	On	Off	Off
14	On	On	Off	On
15	On	On	On	Off
16	On	On	On	On

Table 8: Data Code for BL3-BL6 On/Off Control, Sub-Address 2.

Data	BL2	BL1
1	Off	Off
2	Off	Off
3	Off	Off
4	Off	Off
5	Off	On
6	Off	On
7	Off	On
8	Off	On
9	On	Off
10	On	Off
11	On	Off
12	On	Off
13	On	On
14	On	On
15	On	On
16	On	On

Table 9: Data Code for BL1 and BL2 On/Off Control, Sub-Address 3.

Flash/Movie Mode Operation

The flash LED current level is set via the serial interface according to a logarithmic scale where each code is 1.2dB lower than the previous code as a percentage of the maximum current set by an external resistor, R_{FSET} from FSET to AGND. Flash LED current is set between 14% and 100% of the maximum current for both channels through Address 4. For lower current applications such as torch, flashlight, or movie light, write to Address 5 to enable only FL1 or only FL2. For higher LED current, the flash channels can be connected in parallel to drive the sum of the two channel currents into a single LED.

Flash Strobe Input

The AAT2846 features an active high flash enable input, FEN, that overrides the AS²Cwire programming and drives both flash outputs, FL1 and FL2, at the maximum current set by the flash current setting resistor R_{FSET} . This signal also triggers an internal protection timer. When the FEN input is strobed low, the flash current is turned off independent of the internal timer. If FEN remains high at the end of the protection timer period, the flash LEDs are turned off. Make sure that the maximum time set by the external C_T capacitor is such that the flash LEDs remain within their power dissipation limit at the maximum current set by R_{FSET} . Contact the LED manufacturer for details on the thermal limitations of the LEDs used. When FEN is used to control the flash LEDs, flash on/off control set by Address 6 is automatically reset.

Flash Protection Timer

The AAT2846 includes a protection timer set by the capacitor C_T connected from C_T to AGND. The timer is used to avoid thermal issues with flash LEDs operating above their continuous power rating should a data error occur in the controller. The flash protection time, T_F , is calculated by the following equation:

$$T_F = 10 \cdot C_T$$

where T_F is in seconds and C_T is in μF .

For example: if $C_T = 0.1\mu\text{F}$:

$$\begin{aligned} T_F &= 10 \cdot 0.1\mu\text{F} \\ &= 1\text{s} \end{aligned}$$

Low Dropout Regulators

The AAT2846 includes two independent LDO linear regulators. The regulators operate from a 2.7V to 5.5V input voltage at IN. The AAT2846 supplies separate LDO enable inputs (ENA and ENB) to control individually the operation of the LDOs. The LDO output voltages are set through resistive voltage dividers from the output (OUTA or OUTB) to the feedback input (FBA or FBB). The regulator controls the output voltage such that the voltage divider output is at the 1.2V feedback threshold. The low 200mV dropout voltage at 200mA load current allows the regulator to maintain output voltage regulation.

Each LDO regulator can supply up to 200mA continuous current to the load. They include current limiting and thermal overload protection to prevent damage to the load or to the LDOs.

Applications Information

LDO Output Voltage Programming

The output voltages for LDOA and LDOB are programmed by an external resistor divider network. As shown below, the selection of R_1 and R_2 is a straight forward matter.

R_1 is chosen by considering the tradeoff between the feedback network bias current and resistor value. Higher resistor values allow stray capacitance to become a larger factor in circuit performance whereas lower resistor values increase bias current and decrease efficiency.

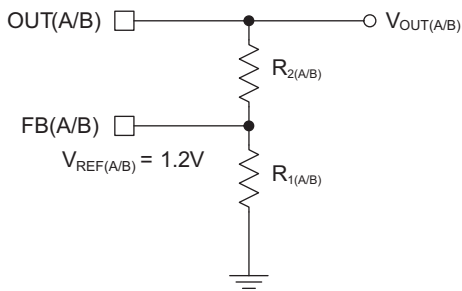

To select appropriate resistor values, first choose R_1 such that the feedback network bias current is less than $10\mu\text{A}$. Then, according to the desired V_{OUT} , calculate R_2 according to the equation below. An example calculation follows.

An R_1 value of 120K is chosen, resulting in a small feedback network bias current of $1.2\text{V}/120\text{K} = 10\mu\text{A}$. The desired output voltage is 1.8V. From this information, R_2 is calculated from the equation below.

$$R_2 = \frac{R_1(V_{\text{OUT}} - 1.2\text{V})}{1.2\text{V}}$$

The result is $R_2 = 60\text{K}$. Since 60K is not a standard 1%-value, 60.4K is selected. From this example calculation, for $V_{\text{OUT}} = 1.8\text{V}$, use $R_1 = 120\text{K}$ and $R_2 = 60.4\text{K}$. Example output voltages and corresponding resistor values are provided in Table 11.

R ₂ Standard 1% Values (R ₁ = 120K)	
V _{OUT} (V)	R ₂ (Ω)
2.8	160K
2.5	130K
2.0	79.6K
1.8	60.4K
1.5	30.1K

Table 10: Example Output Voltages and Corresponding Resistor Values

Altering the Maximum Flash LED Current Level

R_{FSET} determines the maximum LED current level at each of the F1 and F2 flash LED outputs. In the typical application, selecting $R_{\text{FSET}} = 280\text{K}$ results in 300mA/ch LED current. From this reference point, the maximum current level can be modified by calculating an alternative R_{FSET} value:

$$R_{\text{FSET}} = \frac{300\text{mA} \cdot 280\text{k}\Omega}{I_{\text{LED(MAX)}}$$

This is illustrated in Figure 4.

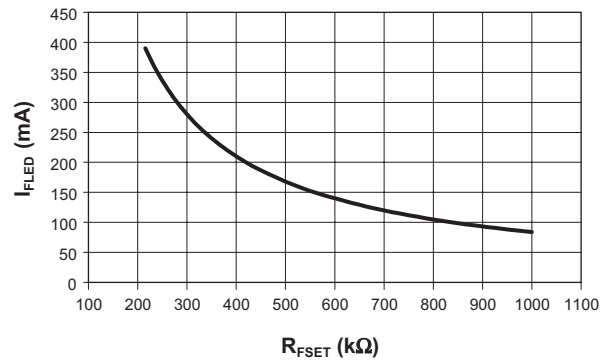

Figure 4: Maximum Flash LED Current vs. R_{FSET} .

Selection of set resistor values outside of the typical application must be carefully evaluated to ensure that the application's performance requirements can still be met.

Device Power Efficiency

The AAT2846 power conversion efficiency depends on the charge pump mode. By definition, device efficiency is expressed as the output power delivered to the LEDs divided by the total input power consumed.

$$\eta = \frac{P_{\text{OUT}}}{P_{\text{IN}}}$$

When the input voltage is sufficiently greater than the LED forward voltages, the device optimizes efficiency by operating in 1X mode. In 1X mode, the device is working as a bypass switch and passing the input supply directly to the output. By simplifying the conditions such that the LEDs have uniform V_f , the power conversion efficiency can be approximated by:

ChargePump™ High Current Charge Pump with Dual LDO for Backlight and Flash Applications

$$\eta = \frac{V_F \cdot I_{LED}}{V_{IN} \cdot I_{IN}} \approx \frac{V_F}{V_{IN}}$$

Due to the very low 1X mode quiescent current, the input current nearly equals the total output current delivered to the LEDs. Further, the low-resistance bypass switch introduces negligible voltage drop from input to output.

The AAT2846 further maintains optimized performance and efficiency by detecting when the input voltage is not sufficient to sustain LED drive current. The device automatically switches to 1.5X mode when the input voltage drops too low in relation to the LED forward voltages.

In 1.5X mode, the output voltage can be boosted to 3/2 the input voltage. The 3/2 conversion ratio introduces a corresponding 1/2 increase in input current. For ideal conversion, the 1.5X mode efficiency is given by:

$$\eta = \frac{V_F \cdot I_{LED}}{V_{IN} \cdot 1.5I_{IN}} = \frac{V_F}{1.5 \cdot V_{IN}}$$

Similarly, when the input falls further, such that 1.5X mode can no longer sustain LED drive current, the device will automatically switch to 2X mode. In 2X mode, the output voltage can be boosted to twice the input voltage. The doubling conversion ratio introduces a corresponding doubling of the input current. For ideal conversion, the 2X mode efficiency is given by:

$$\eta = \frac{V_F \cdot I_{LED}}{V_{IN} \cdot 2I_{IN}} = \frac{V_F}{2 \cdot V_{IN}}$$

LED Selection

The AAT2846 is designed to drive high-intensity white LEDs. It is particularly suitable for LEDs with an operating forward voltage in the range of 1.5V to 4.2V.

The charge pump can also drive other loads that have similar characteristics to white LEDs. For various load types, the AAT2846 provides a high-current, programmable ideal constant current source.

Capacitor Selection

Careful selection of the four external capacitors C_{IN} , C_1 , C_2 , and C_{OUT} is important because they will affect turn-on time, output ripple, and transient performance. Optimum performance will be obtained when low equivalent series resistance (ESR) ceramic capacitors are used. In general, low ESR may be defined as less than 100mΩ.

Ceramic composition capacitors are highly recommended over all other types of capacitors for use with the AAT2846. Ceramic capacitors offer many advantages over their tantalum and aluminum electrolytic counterparts. A ceramic capacitor typically has very low ESR, is lowest cost, has a smaller PCB footprint, and is non-polarized. Low ESR ceramic capacitors help maximize charge pump transient response. Since ceramic capacitors are non-polarized, they are not prone to incorrect connection damage.

Equivalent Series Resistance

ESR is an important characteristic to consider when selecting a capacitor. ESR is a resistance internal to a capacitor that is caused by the leads, internal connections, size or area, material composition, and ambient temperature. Capacitor ESR is typically measured in milliohms for ceramic capacitors and can range to more than several ohms for tantalum or aluminum electrolytic capacitors.

Ceramic Capacitor Materials

Ceramic capacitors less than 0.1μF are typically made from NPO or COG materials. NPO and COG materials generally have tight tolerance and are very stable over temperature. Larger capacitor values are usually composed of X7R, X5R, Z5U, or Y5V dielectric materials. Large ceramic capacitors are often available in lower-cost dielectrics, but capacitors greater than 10μF are not typically required for AAT2846 applications.

Capacitor area is another contributor to ESR. Capacitors that are physically larger will have a lower ESR when compared to an equivalent material smaller capacitor. These larger devices can improve circuit performance when compared to an equal value capacitor in a smaller package size.

PCB Layout

To achieve adequate electrical and thermal performance, careful attention must be given to the PCB layout. In the worst-case operating condition, the chip must dissipate considerable power at full load. Adequate heat-sinking must be achieved to ensure intended operation.

Figure 5 illustrates an example PCB layout. The bottom of the package features an exposed metal paddle. The exposed paddle acts, thermally, to transfer heat from the chip and, electrically, as a ground connection.

ChargePump™ High Current Charge Pump with Dual LDO for Backlight and Flash Applications

The junction-to-ambient thermal resistance (θ_{JA}) for the connection can be significantly reduced by following a couple of important PCB design guidelines.

The PCB area directly underneath the package should be plated so that the exposed paddle can be mated to the top layer PCB copper during the re-flow process. Multiple copper plated thru-holes should be used to electrically and thermally connect the top surface paddle area to additional ground plane(s) and/or the bottom layer ground pour.

The chip ground is internally connected to both the paddle and to the AGND and PGND pins. It is good practice to connect the GND pins to the exposed paddle area with traces as shown in the example.

The flying capacitors C1 and C2 should be connected close to the IC. Trace length should be kept short to minimize path resistance and potential coupling. The input and output capacitors should also be placed as close to the chip as possible.

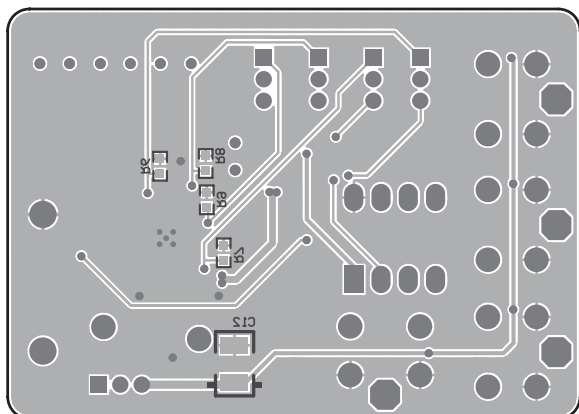

Figure 5: Example PCB Layout.

Evaluation Board User Interface

The user interface for the AAT2846 evaluation board is provided through 4 buttons and a number of connection terminals. The board is operated by supplying external power and pressing individual buttons or button combinations. The table below indicates the function of each button or button combination.

To power-on the board, connect a power supply or battery to the DC- and DC+ terminals. Make the board's supply connection by positioning the J1 jumper to the ON position. A red LED indicates that power is applied.

The evaluation board is made flexible so that the user can disconnect the enable lines from the microcontroller and apply external enable signals. By removing the jumpers from J2, J3, J4 and/or J5, external enable signals can be applied to the board. External enable signals must be applied to pin 1 of each J2, J3, J4 or J5 terminal.

When applying external enable signals, consideration must be given to the voltage levels. The externally applied voltages cannot exceed the supply voltage that is applied to the IN pins of the device (DC+).

The LDO loads can be connected directly to the evaluation board. For adequate performance, be sure to connect the load between OUTA/OUTB and DC- as opposed to some other GND in the system.

ChargePump™ High Current Charge Pump with Dual LDO for Backlight and Flash Applications

Button(s) Pushed	Description
DATA	Increment the data setting for the most recently activated mode. With backlight or movie mode activated, hold down the button to auto-cycle through the brightness levels.
LIGHT	Toggle ON/OFF the backlighting section. Set the brightness level using the DATA button (defaults to Data 1).
LIGHT+DATA	Decrement the brightness setting for backlight mode. Hold down to auto-cycle.
MOVIE	Toggle ON/OFF movie mode illumination. Set the brightness level using the DATA button (defaults to Data 10).
MOVIE+DATA	Decrement the brightness setting for movie mode. Hold down to auto-cycle.
FLASH	Generate a flash pulse. Pulse duration is the lesser of 2 seconds or the CT value result. Set the brightness level using the DATA button (defaults to Data 1).
FLASH+DATA	Toggle ON/OFF the LDOs.
LIGHT+MOVIE+FLASH	Reset. Clear all data and bring all enable lines low.

Table 11: AAT2846 Evaluation Board User Interface.

Evaluation Board Layout

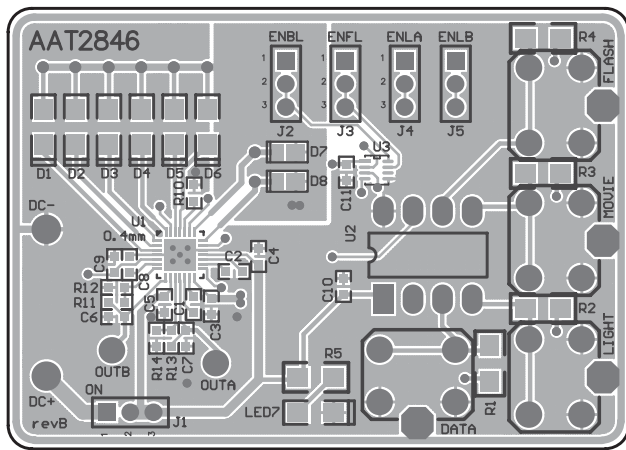

Figure 6: AAT2846 Evaluation Board Layout Top Side.

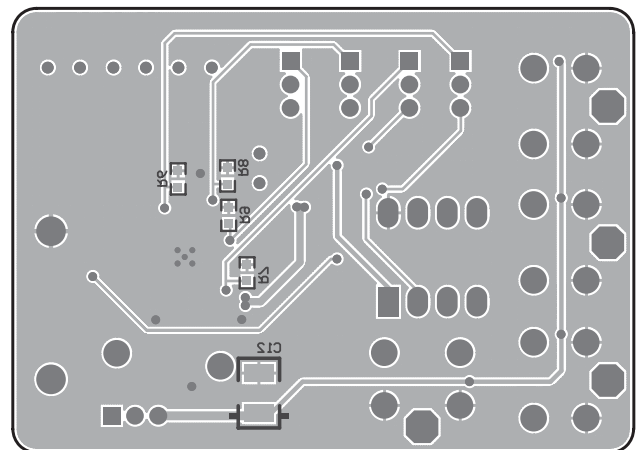

Figure 7: AAT2846 Evaluation Board Layout Bottom Side.

Evaluation Board Schematics

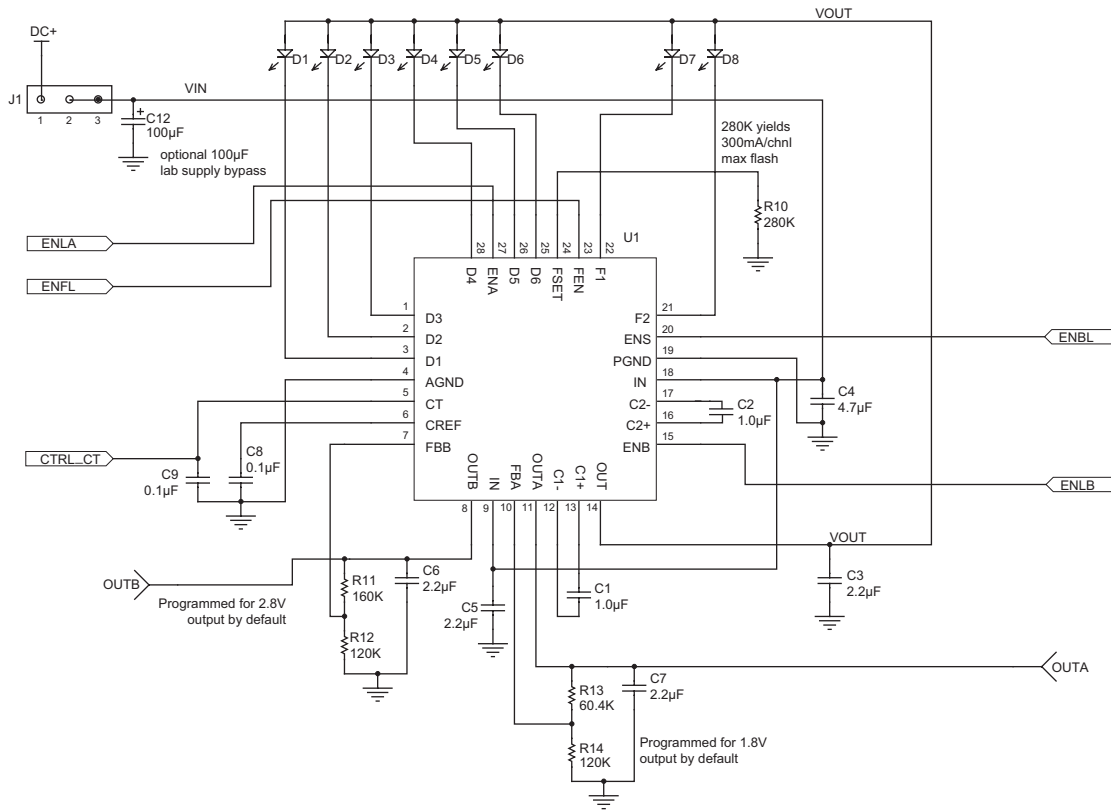

Figure 8: AAT2846 Section Schematic.

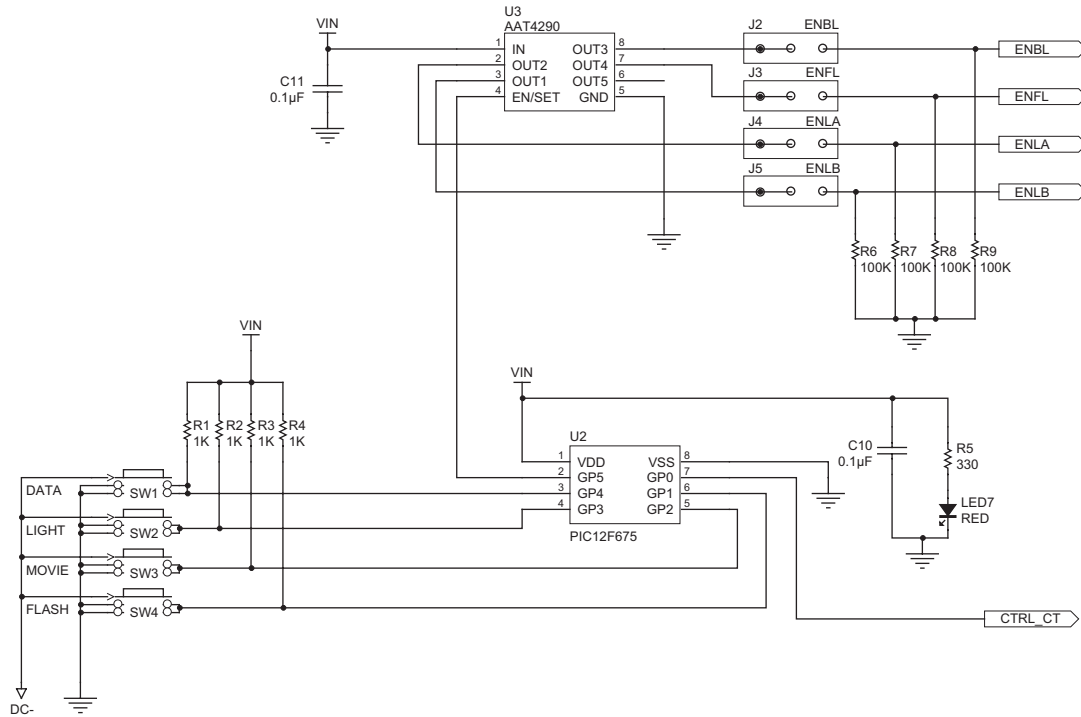

Figure 9: MCU and I/O Expander Section Schematic.

Evaluation Board Component Listing

Component	Part#	Description	Manufacturer
U1	AAT2846INJ-EE-T1	High Eff. 1X/1.5X/2X CP for White LED, Dual LDO	AnalogicTech
U2	PIC12F675	8-bit CMOS, FLASH MCU; 8-pin PDIP	Microchip
U3	AAT4290IJS-1-T1	I/O Expander	AnalogicTech
D1-D6	LW M673	Mini TOPLED White LED; SMT	OSRAM
D7, D8	LXCL-PWF1	Luxeon Flash LED	Lumileds
C1, C2	GRM18x	1.0µF, 10V, X5R, 0603, Ceramic	Murata
C3-C7	GRM18x	2.2µF, 10V, X5R, 0603, Ceramic	Murata
C4	GRM18x	4.7µF, 10V, X5R, 0603, Ceramic	Murata
C8-C11	GRM18x	0.1µF, 16V, X7R, 0603, Ceramic	Murata
C12	TAJbx	100µF, 10V, 10µA, Tantalum	AVX
R1-R4	Chip Resistor	1K, 5%, 1/4W; 1206	Vishay
R5	Chip Resistor	330, 5%, 1/4W; 1206	Vishay
R6-R9	Chip Resistor	100K, 5%, 1/10W; 0603	Vishay
R10	Chip Resistor	280K, 1%, 1/10W; 0603	Vishay
R11	Chip Resistor	160K, 1%, 1/10W; 0603	Vishay
R12, R14	Chip Resistor	120K, 1%, 1/10W; 0603	Vishay
R13	Chip Resistor	60.4K, 1%, 1/10W; 0603	Vishay
J1-J5	PRPN401PAEN	Conn. Header, 2mm Zip	Sullins Electronics
LED7	CMD15-21SRC/TR8	Red LED; 1206	Chicago Miniature Lamp
SW1-SW4	PTS645TL50	Switch Tact, SPST, 5mm	ITT Industries



ChargePump™ High Current Charge Pump with Dual LDO for Backlight and Flash Applications

Ordering Information

Package	Marking ¹	Part Number (Tape and Reel) ²
TQFN44-28-0.4	UPXY	AAT2846INJ-EE-T1



All AnalogicTech products are offered in Pb-free packaging. The term "Pb-free" means semiconductor products that are in compliance with current RoHS standards, including the requirement that lead not exceed 0.1% by weight in homogeneous materials. For more information, please visit our website at <http://www.analogictech.com/about/quality.aspx>.

1. XYY = assembly and date code.

2. Sample stock is generally held on part numbers listed in **BOLD**.

ChargePump™ High Current Charge Pump with Dual LDO for Backlight and Flash Applications

Package Information¹

TQFN44-28-0.4

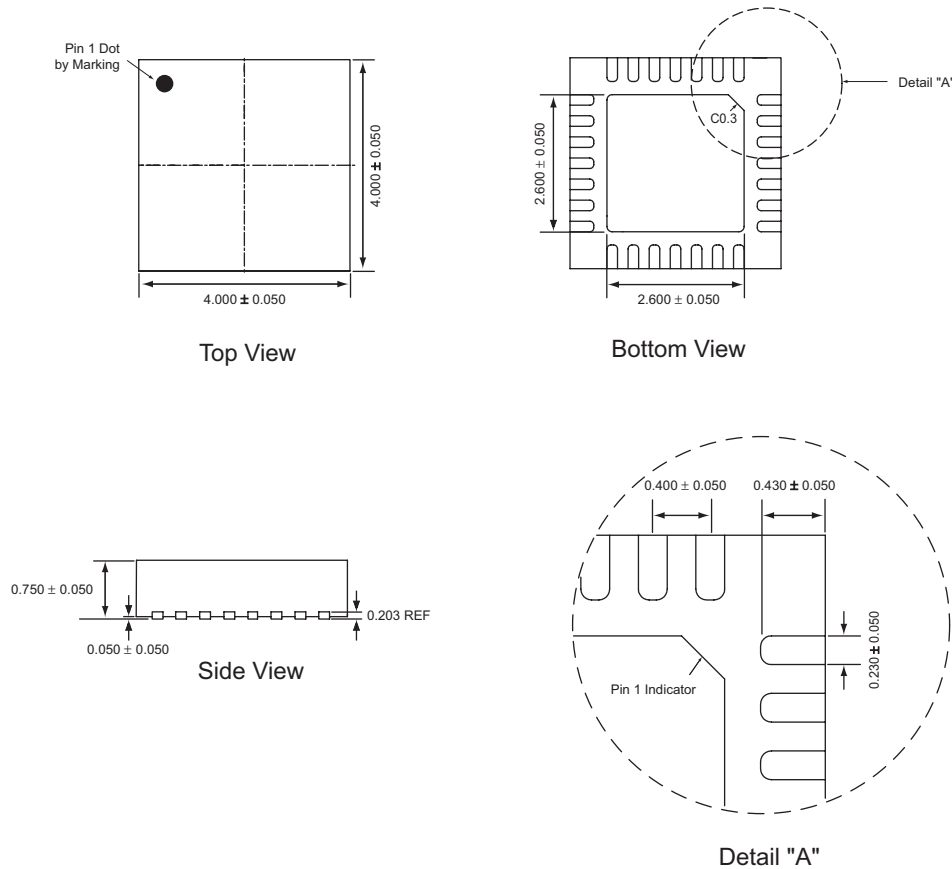

All dimensions in millimeters.

1. The leadless package family, which includes QFN, TQFN, DFN, TDFN and STDFN, has exposed copper (unplated) at the end of the lead terminals due to the manufacturing process. A solder fillet at the exposed copper edge cannot be guaranteed and is not required to ensure a proper bottom solder connection.

Advanced Analogic Technologies, Inc.
 3230 Scott Boulevard, Santa Clara, CA 95054
 Phone (408) 737-4600
 Fax (408) 737-4611



© Advanced Analogic Technologies, Inc. AnalogicTech cannot assume responsibility for use of any circuitry other than circuitry entirely embodied in an AnalogicTech product. No circuit patent licenses, copyrights, mask work rights, or other intellectual property rights are implied. AnalogicTech reserves the right to make changes to their products or specifications or to discontinue any product or service without notice. Except as provided in AnalogicTech's terms and conditions of sale, AnalogicTech assumes no liability whatsoever, and AnalogicTech disclaims any express or implied warranty relating to the sale and/or use of AnalogicTech products including liability or warranties relating to fitness for a particular purpose, merchantability, or infringement of any patent, copyright or other intellectual property right. In order to minimize risks associated with the customer's applications, adequate design and operating safeguards must be provided by the customer to minimize inherent or procedural hazards. Testing and other quality control techniques are utilized to the extent AnalogicTech deems necessary to support this warranty. Specific testing of all parameters of each device is not necessarily performed. AnalogicTech and the AnalogicTech logo are trademarks of Advanced Analogic Technologies Incorporated. All other brand and product names appearing in this document are registered trademarks or trademarks of their respective holders.