

DATA SHEET

SMV1702: Hyperabrupt Junction Tuning Varactors

Features

- Designed for high-volume, low-cost battery applications
- Low series resistance
- High capacitance ratio
- Available lead (Pb)-free and RoHS-compliant MSL-1 @ 260 °C per JEDEC J-STD-020
- SOD-323 package
- Available in tape and reel packaging



Description

The SMV1702 devices are silicon hyperabrupt junction varactor diodes specifically designed for battery operation. The specified high capacitance ratio and low R_S of these varactors make them appropriate for low noise VCOs used at frequencies in wireless systems. Applications include low-noise and wideband UHF and VHF VCOs.

NEW Skyworks offers lead (Pb)-free, RoHS (Restriction of Hazardous Substances)-compliant packaging.



Absolute Maximum Ratings

Characteristic	Value
Forward current (I_F)	20 mA
Power dissipation (P_D)	250 mW
Storage temperature (T_{ST})	-55 °C to +150 °C
Operating temperature (T_{OP})	-55 °C to +125 °C
ESD human body model	Class 0

Performance is guaranteed only under the conditions listed in the specifications table and is not guaranteed under the full range(s) described by the Absolute Maximum specifications. Exceeding any of the absolute maximum/minimum specifications may result in permanent damage to the device and will void the warranty.

CAUTION: Although this device is designed to be as robust as possible, ESD (Electrostatic Discharge) can damage this device. This device must be protected at all times from ESD. Static charges may easily produce potentials of several kilovolts on the human body or equipment, which can discharge without detection. Industry-standard ESD precautions must be employed at all times.

Electrical Specifications at 25 °C

Parameter	Condition	Min.	Typ.	Max.	Unit
Reverse Current (I_R)	$V_R = 8\text{ V}$		< 0.01	20	nA
Capacitance (C_T)	$V_R = 0.1\text{ V}, F = 1\text{ MHz}$	90	100	110	pF
Capacitance (C_T)	$V_R = 2\text{ V}, F = 1\text{ MHz}$	41	46	50	pF
Capacitance (C_T)	$V_R = 4\text{ V}, F = 1\text{ MHz}$	22	25	29	pF
Capacitance Ratio (C_{TR})	$C_T(0.1\text{ V})/C_T(4\text{ V})$	3.6	4		
Series Resistance (R_S)	$V_R = 5\text{ V}, F = 470\text{ MHz}$		0.45	1.25	Ω
Breakdown Voltage (V_{BR})	$I_R = 10\ \mu\text{A}$	10			V

Single
SOD-323
SMV1702-011
Marking: CJ
SMV1702-011LF
Marking: HJ
$L_S = 1.5\text{ nH}$

 LF denotes lead (Pb)-free, RoHS-compliant packaging option as an alternative to our standard tin/lead (Sn/Pb) packaging.

Typical Performance Data

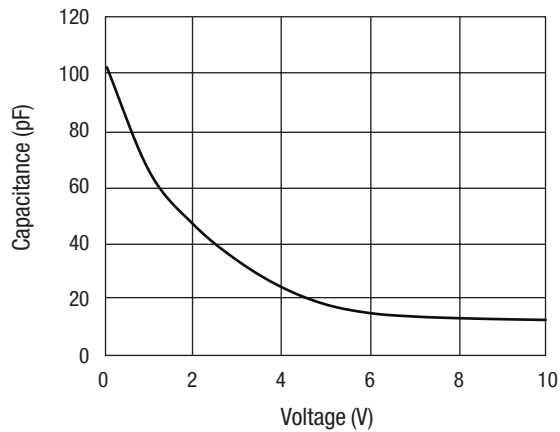

Capacitance vs. Voltage

Capacitance vs. Voltage

V_R (V)	C_T (pF)
0	103.3
1	65.1
2	46.38
3	33.57
4	24.2
5	18.08
6	15.01
7	13.8
8	13.21
9	12.84
10	12.58

Recommended Solder Reflow Profiles

Refer to the [“Recommended Solder Reflow Profile”](#) Application Note.

Tape and Reel Information

Refer to the [“Discrete Devices and IC Switch/Attenuators Tape and Reel Package Orientation”](#) Application Note.

SPICE Model

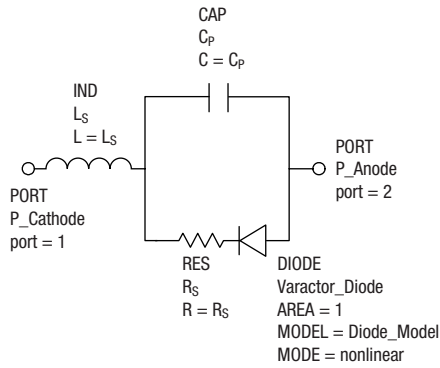

SOD-323

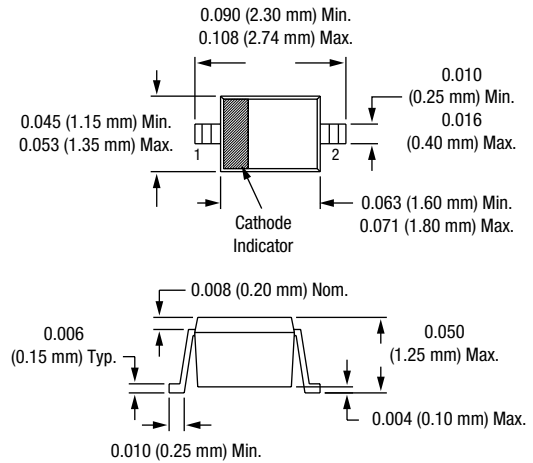

SPICE Model Parameters

Parameter	Description	Unit	Value	Default
IS	Saturation current (with N, determine the DC characteristics of the diode)	A		1e-14
R _S	Series resistance		0.5	0
N	Emission coefficient (with IS, determines the DC characteristics of the diode)	-		1
TT	Transit time	s		0
C _{J0}	Zero-bias junction capacitance (with V _J and M define nonlinear junction capacitance of the diode)	F	120e-12	0
V _J	Junction potential (with V _J and M define nonlinear junction capacitance of the diode)	V	0.89	1
M	Grading coefficient (with V _J and M define nonlinear junction capacitance of the diode)	-	0.925	0.5
E _G	Energy gap (with XTI, helps define the dependence of IS on temperature)	eV		1.11
XTI	Saturation current temperature exponent (with E _G , helps define the dependence of IS on temperature)	-		3
KF	Flicker noise coefficient	-		0
AF	Flicker noise exponent	-		1
FC	Forward-bias depletion capacitance coefficient	-		0.5
B _V	Reverse breakdown voltage	V	18	
I _{BV}	Current at reverse breakdown voltage	A	1e-5	1e-3
ISR	Recombination current parameter	A		0
NR	Emission coefficient for ISR	-		2
IKF	High-injection knee current	A		
NBV	Reverse breakdown ideality factor	-		1
IBVL	Low-level reverse breakdown knee current	A		0
NBVL	Low-level reverse breakdown ideality factor	-		1
TNOM	Nominal ambient temperature at which these model parameters were derived	°C		27
FFE	Flicker noise frequency exponent	-		1
Cpkg		pF	0.12	
LS		nH	1.5	

The table contains typical SPICE parameters for SMV1720-011. The default value should be used for any parameter for which the "value" column is blank.

Copyright © 2002, 2003, 2004, 2005, 2006, Skyworks Solutions, Inc. All Rights Reserved.

Information in this document is provided in connection with Skyworks Solutions, Inc. ("Skyworks") products or services. These materials, including the information contained herein, are provided by Skyworks as a service to its customers and may be used for informational purposes only by the customer. Skyworks assumes no responsibility for errors or omissions in these materials or the information contained herein. Skyworks may change its documentation, products, services, specifications or product descriptions at any time, without notice. Skyworks makes no commitment to update the materials or information and shall have no responsibility whatsoever for conflicts, incompatibilities, or other difficulties arising from any future changes.

No license, whether express, implied, by estoppel or otherwise, is granted to any intellectual property rights by this document. Skyworks assumes no liability for any materials, products or information provided hereunder, including the sale, distribution, reproduction or use of Skyworks products, information or materials, except as may be provided in Skyworks Terms and Conditions of Sale.

THE MATERIALS, PRODUCTS AND INFORMATION ARE PROVIDED "AS IS" WITHOUT WARRANTY OF ANY KIND, WHETHER EXPRESS, IMPLIED, STATUTORY, OR OTHERWISE, INCLUDING FITNESS FOR A PARTICULAR PURPOSE OR USE, MERCHANTABILITY, PERFORMANCE, QUALITY OR NON-INFRINGEMENT OF ANY INTELLECTUAL PROPERTY RIGHT; ALL SUCH WARRANTIES ARE HEREBY EXPRESSLY DISCLAIMED. SKYWORKS DOES NOT WARRANT THE ACCURACY OR COMPLETENESS OF THE INFORMATION, TEXT, GRAPHICS OR OTHER ITEMS CONTAINED WITHIN THESE MATERIALS. SKYWORKS SHALL NOT BE LIABLE FOR ANY DAMAGES, INCLUDING BUT NOT LIMITED TO ANY SPECIAL, INDIRECT, INCIDENTAL, STATUTORY, OR CONSEQUENTIAL DAMAGES, INCLUDING WITHOUT LIMITATION, LOST REVENUES OR LOST PROFITS THAT MAY RESULT FROM THE USE OF THE MATERIALS OR INFORMATION, WHETHER OR NOT THE RECIPIENT OF MATERIALS HAS BEEN ADVISED OF THE POSSIBILITY OF SUCH DAMAGE.

Skyworks products are not intended for use in medical, lifesaving or life-sustaining applications, or other equipment in which the failure of the Skyworks products could lead to personal injury, death, physical or environmental damage. Skyworks customers using or selling Skyworks products for use in such applications do so at their own risk and agree to fully indemnify Skyworks for any damages resulting from such improper use or sale.

Customers are responsible for their products and applications using Skyworks products, which may deviate from published specifications as a result of design defects, errors, or operation of products outside of published parameters or design specifications. Customers should include design and operating safeguards to minimize these and other risks. Skyworks assumes no liability for applications assistance, customer product design, or damage to any equipment resulting from the use of Skyworks products outside of stated published specifications or parameters.

Skyworks, the Skyworks symbol, and "Breakthrough Simplicity" are trademarks or registered trademarks of Skyworks Solutions, Inc., in the United States and other countries. Third-party brands and names are for identification purposes only, and are the property of their respective owners. Additional information, including relevant terms and conditions, posted at www.skyworksinc.com, are incorporated by reference.