



M.S.KENNEDY CORP.

HIGH PERFORMANCE, HIGH VOLTAGE VIDEO DISPLAY DRIVER

1911

4707 Dey Road Liverpool, N.Y. 13088

(315) 701-6751

FEATURES:

- Internal Load Resistor for Highest Bandwidth
- Ultra Fast Rise Time - 2.0nS Typical
- Wide Bandwidth - 225 MHz Typical
- Variable Gain - 0 to 100 V/V
- On Board Reference Output
- 60 Vpp Output Voltage Swing
- Blanking Capability
- User Adjustable Brightness and Contrast
- 25,000 V/ μ Sec Slew Rate
- Low Cost Complete Video CRT Driver System

MIL-PRF-38534 CERTIFIED

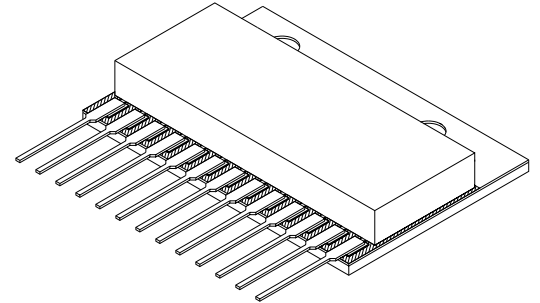

DESCRIPTION:

The MSK 1911 is a high performance, high voltage, variable gain video amplifier capable of directly driving high resolution video displays.

The MSK 1911 features differential inputs and a linearly adjustable gain stage with an output offset adjustment which allows it to be a versatile performer well suited for many applications. A TTL level blanking input is available to set the output to a predetermined black level independent of signal input.

The MSK 1911 is packaged in a cost effective, highly thermally conductive, insulated package which can be bolted directly to a heat sink for efficient thermal management.

EQUIVALENT SCHEMATIC

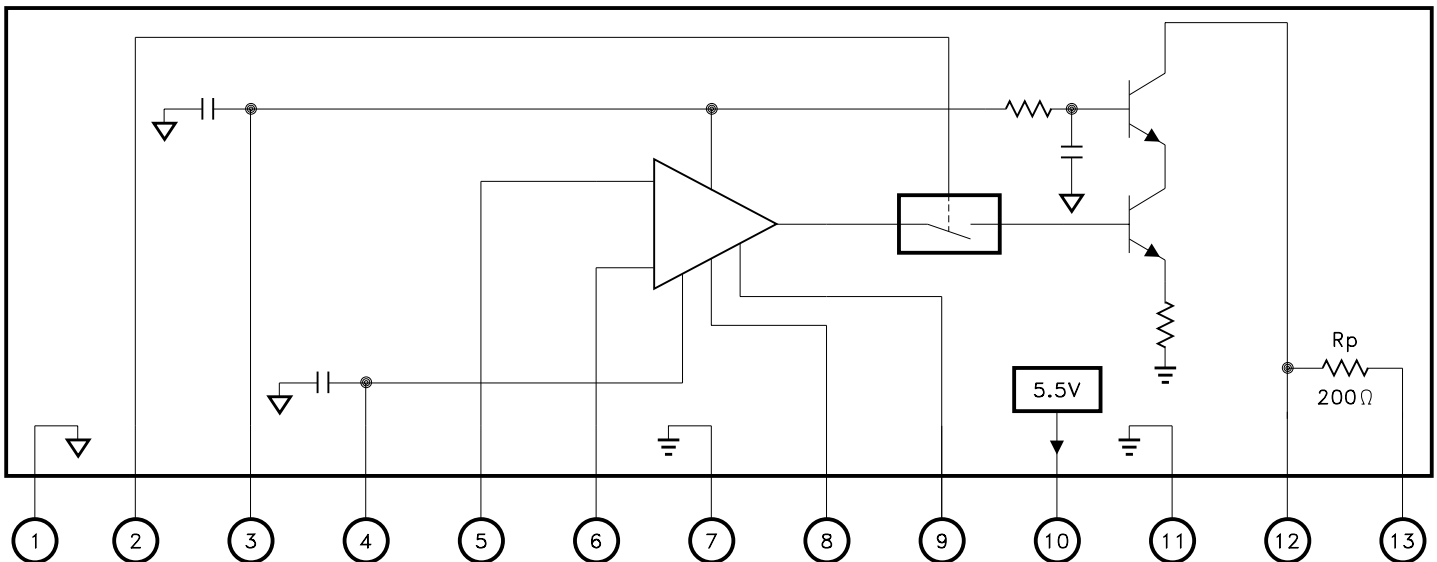

TYPICAL APPLICATIONS

- High Resolution Mono-Chrome Displays
- High Resolution RGB Displays
- High Speed, High Voltage Amplification for ATE

PIN-OUT INFORMATION

1	Ground	8	VGAIN
2	Blank	9	VOFF
3	VCC	10	VREF
4	VEE	11	Ground
5	-Input	12	Output
6	+Input	13	+VHV
7	Ground		

ABSOLUTE MAXIMUM RATINGS

+V _{HV}	High Voltage Supply	+75V	T _{ST}	Storage Temperature Range	-65°C to +150°C
+V _{CC}	Positive Supply Voltage	+12V	T _{LD}	Lead Temperature Range	+300°C (Solder 10 Seconds)
-V _{EE}	Negative Supply Voltage	-12V	T _J	Junction Temperature	+175°C
V _{ID}	Differential Input Voltage	2V	P _D	Total Power Dissipation	13W (T _C = 25°C)
V _{GAIN}	Gain Adjust Input Voltage	-0.6V to +6V	T _C	Case Operating Temperature	MSK 1911
V _{OFF}	Offset Adjust Input Voltage	-0.6V to +6V			-25°C to +85°C
V _{BLANK}	Blank Input Voltage	-0.6V to +6V			
I _{REF}	Reference Output Current	5mA			

ELECTRICAL SPECIFICATIONS

T_C = 25°C unless otherwise specified

Parameter	Test Conditions ①	MSK 1911			Units
		Min.	Typ.	Max.	
STATIC					
Quiescent Current ④	V _{CM} = 0V @ +10V	-	85	110	mA
	V _{CM} = 0V @ -10.5V	-	-75	-100	mA
High Voltage Supply ②	T _C ≤ 85°C	50	70	75	V
Thermal Resistance to Case		-	3.2	7	°C/W
INPUT					
Input Bias Current ②	V _{CM} = 0V T _C = 25°C	-	±1	±50	μA
	⑤ V _{CM} = 0V Full Temp.	-	±5	±250	μA
Blank Input Current ②	V _{BLANK} = 0.4V	-	500	600	μA
	V _{BLANK} = 2.4V	-	300	400	μA
Offset Adjust Input Current ② ⑤	V _{OFF} = 1V	-	2	10	μA
Gain Adjust Input Current ② ⑤	V _{GAIN} = 5V	-	2	10	μA
Blank Input Pulse Width ②	Normal Operation	30	-	-	nS
Common Mode Rejection Ratio ②	V _{CM} = ±0.5V F = 10Hz	-	40	-	dB
Input Impedance ②	Either Input F = DC	10K	20K	-	Ω
Input Capacitance ②	Either Input	-	2	-	pF
Blank Mode Input Rejection ΔV ②	V _{BLANK} = 2.4V V _{IN} = 0.3V	-	-	±0.4	V
Gain Adjust Rejection ΔV ②	ΔV _{GAIN} = 5V	-	-	±2.0	V
Power Supply Rejection Ratio ②	+V _{CC} and -V _{EE} = Nom ±5%	25	30	-	dB
OUTPUT					
Reference Output Voltage ④	I _{OUT} < 2mA	5.2	5.5	5.8	V
Output Voltage Blank Mode ΔV ④ ⑥	V _{BLANK} = 2.4V V _{OFF} = 1V V _{GAIN} = 0V	-0.4	0	+0.4	V
Output Voltage (Min Offset) ΔV ⑥	V _{OFF} = 0V V _{GAIN} = 5V	0.1	2.0	8.0	V
Output Voltage (Max Offset) ΔV ② ⑥	V _{OFF} = 5V V _{GAIN} = 0V	12	20	28	V
Voltage Gain ④	V _{IN} = 0.5V F = 10KHz V _{GAIN} = 5V	80	100	120	V/V
Bandwidth ② ③	Either Input	200	225	-	MHz
Transition Times ② ③	V _{OFF} = 0V	-	2.0	-	nS
Linearity Error ②	V _{GAIN} = 3V T _R = T _F < 0.5nS V _{OFF} = 1V	-	-	±2	%GS
Gain Linearity ②	V _{GAIN} = 1V V _{OFF} = 1V V _{CM} = 0.5V	-	-	±2	%
Thermal Distortion ②	V _{OFF} = 1V V _{IN} = 0.2V V _{CM} = 0.5V	-	-	±2	%GS

NOTES:

- ① +V_{CC} = +10V, -V_{EE} = -10.5V, +V_{HV} = +70V, V_{BLANK} = 0.4V, C_L = 2pF, V_{GAIN} = V_{OFF} = ±V_{IN} = 0V unless otherwise specified.
- ② These parameters are guaranteed by design but need not be tested. Typical parameters are representative of actual device performance but are for reference only.
- ③ Much faster rise times are obtained without using test sockets. In addition, a peaking network may be used to improve overall bandwidth.
- ④ This parameter is tested 100% on production devices.
- ⑤ This parameter is sample tested in accordance with MSK industrial grade quality levels.
- ⑥ Output voltage ΔV is the difference between +V_{HV} and V_{OUT}.

APPLICATION NOTES

POWER SUPPLIES

The input stage of the MSK 1911 requires power supplies of +10V and -10.5V for optimum operation. The negative power supply can be increased to -12V if -10.5V is not available, but additional power dissipation will cause the internal temperature to rise. Both low voltage power supplies should be effectively decoupled with tantalum capacitors (at least 1 μ F) connected as close to the amplifiers pins as possible. The MSK 1911 has internal 0.01 μ F capacitors that also improve high frequency performance. Additionally, it is also recommended to put 0.1 μ F decoupling capacitors on the +10V and -10.5V supplies as well.

The high voltage power supply (+VHV) is connected to the amplifiers output stage and must be kept as stable as possible. The internal Rp is connected to +VHV and as such, the amplifiers DC output is directly related to the high voltage value. The +VHV pin of the hybrid should be decoupled to ground with as large a capacitor as possible to improve output stability.

SUPPLY SEQUENCING

The power supply sequence is +VHV, VCC, VEE followed by the other DC control inputs. If power supply sequencing is not possible, the time difference between each supply should be less than five milliseconds. If the DC control signals are being generated from a low impedance source other than the VREF output, reverse biased diodes should be connected from each input (VGAIN, VOFF) to the +VCC pin. This will protect the inputs until +VCC is turned off.

VIDEO OUTPUT

When power is first applied and VIN = VGAIN = VOFF = 0V, the output will be practically at the +VHV rail voltage. The output voltage is a function of the value of Rp and also the VGAIN and VOFF DC inputs. The bandwidth of the amplifier largely depends on both Rp and Lp. With +VHV set to +70V and total Rp = 200 Ω (internal), the device is capable of approximately 62Vpp total output swing.

Hybrid pin 13 is directly connected to Rp. Additional external resistance can be added to reduce power dissipation, but slower transition times will result. If an additional resistor is used, it must be low capacitance and the layout should minimize capacitive coupling to ground (ie: no ground plane under Rp).

The MSK 1911 is conservatively specified with low values for external Lp which yield about 5% overshoot. Additional peaking can be obtained by using a high self-resonant frequency inductor in series with +VHV pin. Since this value of inductance can be very dependent on circuit layout, it is best to determine its value by experimentation. A good starting point is typically 0.47 μ H for the MSK 1911.

If external resistors or inductors are not used, be sure to connect high frequency bypass capacitors directly from pin 13 to ground.

VIDEO INPUTS

The video input signals should be kept below $\pm 2V_{MAX}$ total including both common mode offset and signal levels. The input structure of the MSK 1911 was designed for $\pm 0.714V_{pp}$ RS343 signals. If either input is not used it should be connected directly to the analog ground or through a 25 Ω resistor to ground if input offset currents are to be minimized.

OUTPUT PROTECTION

The output pin of the MSK 1911 can be protected from transients by connecting reversed biased ultra-low capacitance diodes from the output pin to both +VHV and ground. The output can also be protected from arc voltages by inserting a small value (50-100 Ω) resistor in series with the amplifier. This resistor will reduce system bandwidth along with the load capacitance, but a series inductor can reduce the problem substantially.

VGAIN CONTROL INPUT

The VGAIN control (contrast) input is designed to allow the user to vary the video gain. By simply applying a DC voltage from 0V to VREF, the video gain can be linearly adjusted from 0 to 100V/V. The VGAIN input should be connected to the VREF pin through a 5k Ω pot to ground. For convenient stable gain adjustment, a 0.1 μ F bypass capacitor should be connected near the VGAIN input pin to prevent output instability due to noisy sources. Digital gain control can be accomplished by connecting a D/A converter to the VGAIN pin. However, some temperature tracking performance may be lost when using an external DC voltage source other than VREF for gain adjustment.

The overall video output of the MSK 1911 can be characterized using the following expression:

$$V_{pp} = V_{HV} - V_{OUT}$$

$$V_{HV} - V_{OUT} = (V_{IN})(V_{GAIN})(R_p)(0.08)$$

Here is a sample calculation for the MSK1911:
Given information

- VIN = 0.7V
- VGAIN = 1VDC
- Rp = 200 Ω (internal)
- VHV = 70VDC

$$V_{HV} - V_{OUT} = (0.7V)(1V)(.08)(200\Omega)$$

$$V_{HV} - V_{OUT} = 11.2V_{pp} \text{ Nominal}$$

The expected video output would swing from approximately +70V to +58.8V assuming that VOFF = 0V. This calculation should be used as a nominal result because the overall gain may vary as much as $\pm 10\%$ due to internal high speed device variations. Changing ambient conditions can also effect the video gain of the amplifier slightly. It is wise to connect all video amplifiers to a common heat sink to maximize thermal tracking when multiple amplifiers are used in applications such as RGB systems. Additionally, only one of the VREF outputs should be shared by all three amplifiers. This voltage should be buffered with a suitable low-drift op-amp for best tracking performance.

APPLICATION NOTES CON'T

VOFF CONTROL INPUT

The brightness (output offset) can be linearly adjusted by applying a 0 to VREF DC voltage to the VOFF input pin. The output quiescent voltage range is from approximately (10mA)(200Ω) to (100mA)(200Ω) from +VHV. This control voltage is normally generated by connecting the VOFF control pin to a 5K potentiometer between VREF and ground. The VOFF input pin should be bypassed with a 0.1μF capacitor to ground placed as close as possible to the hybrid. This DC voltage can be any stable system source.

Keep hybrid power dissipation in mind when adjusting the output quiescent voltage. Practically all of the voltage is seen across Rp. This power must be taken into account when high Rp currents are used. If the quiescent level is set almost to +VHV, the power dissipation will be minimal but the rise time will suffer somewhat. If the quiescent level is set too far from +VHV, the power dissipation will increase dramatically and the output fall time will be limited. The output black level is obviously dependent on system requirements but a little experimentation will strike the optimum balance between power dissipation and bandwidth. Total current through Rp should be limited to less than 370mA when operating from power supplies greater than 65V. The gain adjust alone can set the AC current to 250mA (ie: 250mApp = 50Vpp/200Ω).

BLANK INPUT

The video input can be electrically disconnected from the amplifier by applying a TTL high input to the blank pin. When this occurs, the output will be set to approximately +VHV. The VGAIN and VOFF control pins have little or no effect on the output when it is in blank mode.

When the TTL compatible blank input is not used, the pin must be connected to ground to enable the amplifier. The blank input will float high when left unconnected which will disable the video.

VREF OUTPUT

The MSK 1911 has an on board buffered DC zener reference output. The VREF output is nominally 5.5V DC and has full temperature test limits of 5.2V to 5.8V DC. This output is provided for gain and offset adjustment and can source up to 4mA of current.

TRANSITION TIME MINIMIZATION

To achieve transition times of less than 3 nS with the MSK 1911, all stray and intrinsic capacitances must be compensated for. Two external inductors can accomplish this task easily. (Refer to the figure below). The 200Ω resistor (Rp) and the capacitance of the output driver collector form a high frequency pole which limits the rise and fall time. To compensate for this effect, the series inductor (Lp) is placed in the circuit between the internal Rp and +VHV. A good starting value for this inductor is typically 100nH. Since all applications are slightly different, it is likely that the designer will need to select this inductor value to achieve the desired response. The second inductor (L2) is only necessary when a series CRT isolation resistor (Rs) is used. An inductor in the range of 30nH is placed in series with the resistor to compensate for the pole formed by the resistor and the CRT capacitance. The value of this inductor may be varied as well for optimum response time.

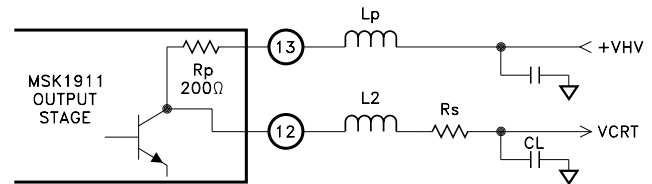

THERMAL MANAGEMENT

The MSK 1911 package has mounting holes that allow the user to connect the amplifier to a heat sink or chassis. Since the package is electrically isolated from the internal circuitry, mounting insulators are not required or desired for best thermal performance.

The power dissipation of the amplifier depends mainly on the load requirements, bandwidth, pixel size, black level and the value of Rp. The following table illustrates an example:

Typical Power Consumption Tc = 25°C

Power Dissipation at +VHV = 70V, Rp = 200Ω (Internal)		
Vo-VBLACK	Duty Cycle %	Total Pd (Watts)
0	0	1.6
35	100	13.9
35	80	11.4
50	80	15.6

RESOLUTION TABLE FOR TYPICAL CRT'S

Display Resolution	Maximum Pixel Time	Minimum Pixel Clock Frequency	Required Rise Time at CRT Cathode	Required System Bandwidth (F-3dB)
320 x 200	182nS	5MHz	60nS	6MHz
640 x 350	52nS	19MHz	17nS	20MHz
640 x 480	38nS	26MHz	12.5nS	28MHz
800 x 560	26nS	38MHz	8.6nS	41MHz
1024 x 900	12.6nS	80MHz	4.2nS	84MHz
1024 x 1024	11nS	90MHz	3.7nS	95MHz
1280 x 1024	8.9nS	112MHz	2.9nS	120MHz
1664 x 1200	5.8nS	170MHz	1.9nS	180MHz
2048 x 2048	2.8nS	360MHz	1nS	380MHz
4096 x 3300	860pS	1.2GHz	280pS	1.23GHz

All data assumes retrace time equal to 30% of frame time and a 60Hz refresh rate.

TYPICAL CONNECTION CIRCUIT

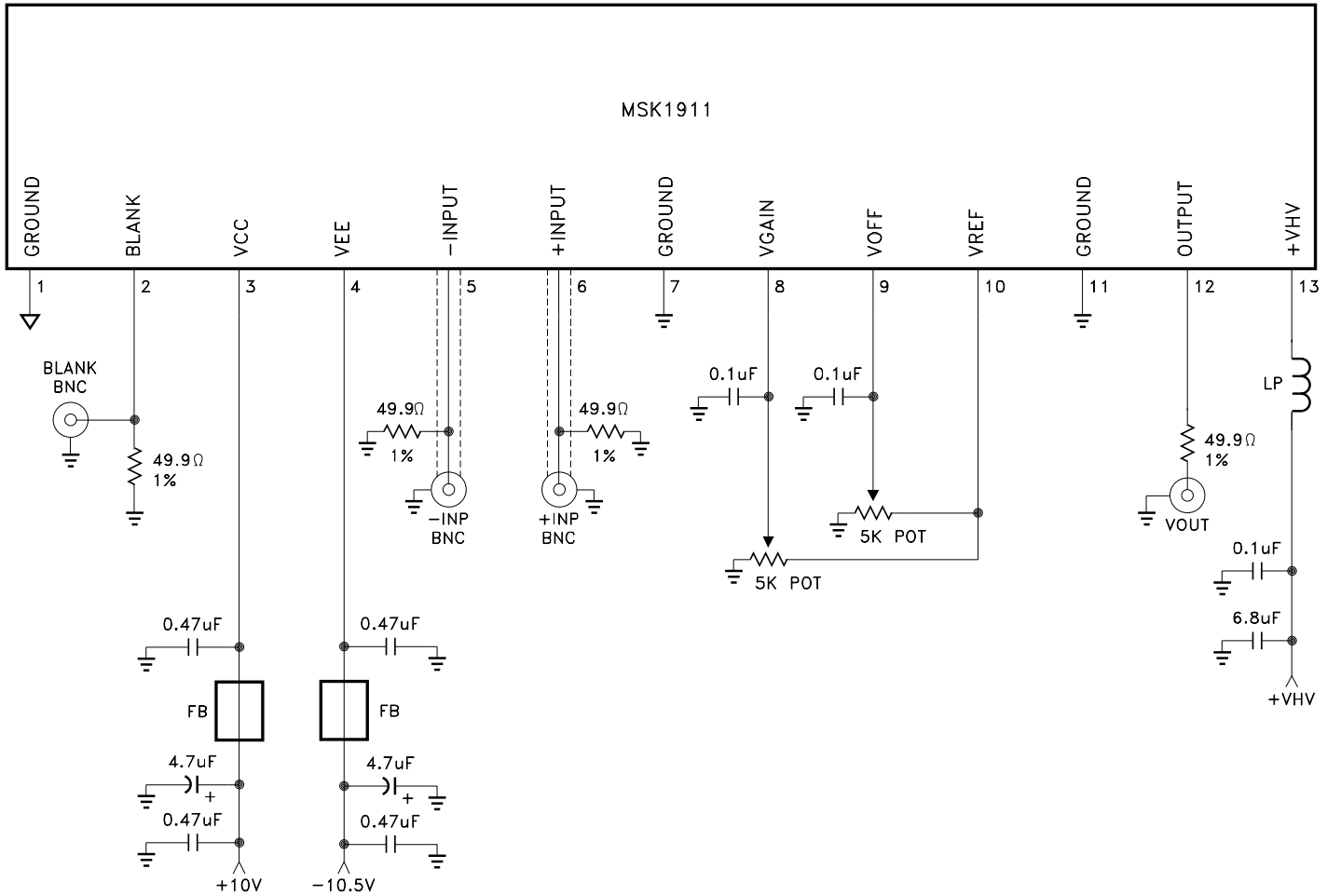

The connection circuit shown above is for the MSK 1911. Lp is an optional external component and must not be located near ground planes if possible. Use an inductor with a high self-resonant frequency that can withstand the currents required for the application. The ferrite beads should be located as close to the DUT as possible. Fare-Rite Corporation P/N 2743001111 beads work well for most applications. For additional applications information, please contact the factory. Evaluation amplifiers with test boards are readily available from M.S.Kennedy Corp.

NOTES: _____

MECHANICAL SPECIFICATIONS

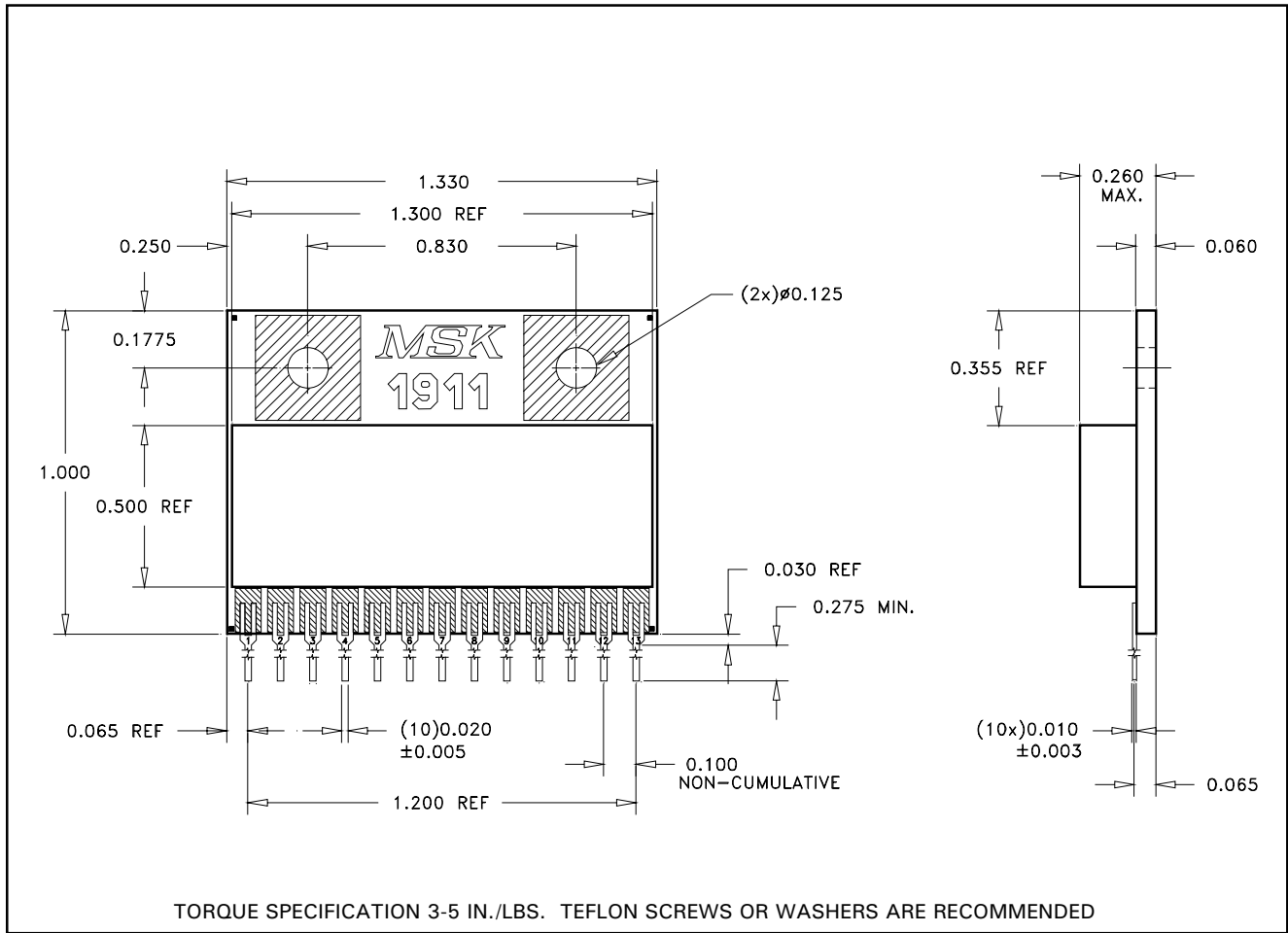

ALL DIMENSIONS ARE ± 0.010 INCHES UNLESS OTHERWISE LABELED

ORDERING INFORMATION

Part Number	Screening Level
MSK1911	Industrial

M.S. Kennedy Corp.
 4707 Dey Road, Liverpool, New York 13088
 Phone (315) 701-6751
 FAX (315) 701-6752
 www.mskennedy.com

The information contained herein is believed to be accurate at the time of printing. MSK reserves the right to make changes to its products or specifications without notice, however, and assumes no liability for the use of its products.