

To all our customers

Regarding the change of names mentioned in the document, such as Hitachi Electric and Hitachi XX, to Renesas Technology Corp.

The semiconductor operations of Mitsubishi Electric and Hitachi were transferred to Renesas Technology Corporation on April 1st 2003. These operations include microcomputer, logic, analog and discrete devices, and memory chips other than DRAMs (flash memory, SRAMs etc.) Accordingly, although Hitachi, Hitachi, Ltd., Hitachi Semiconductors, and other Hitachi brand names are mentioned in the document, these names have in fact all been changed to Renesas Technology Corp. Thank you for your understanding. Except for our corporate trademark, logo and corporate statement, no changes whatsoever have been made to the contents of the document, and these changes do not constitute any alteration to the contents of the document itself.

Renesas Technology Home Page: <http://www.renesas.com>

Renesas Technology Corp.
Customer Support Dept.
April 1, 2003

Cautions

Keep safety first in your circuit designs!

1. Renesas Technology Corporation puts the maximum effort into making semiconductor products better and more reliable, but there is always the possibility that trouble may occur with them. Trouble with semiconductors may lead to personal injury, fire or property damage.
Remember to give due consideration to safety when making your circuit designs, with appropriate measures such as (i) placement of substitutive, auxiliary circuits, (ii) use of nonflammable material or (iii) prevention against any malfunction or mishap.

Notes regarding these materials

1. These materials are intended as a reference to assist our customers in the selection of the Renesas Technology Corporation product best suited to the customer's application; they do not convey any license under any intellectual property rights, or any other rights, belonging to Renesas Technology Corporation or a third party.
2. Renesas Technology Corporation assumes no responsibility for any damage, or infringement of any third-party's rights, originating in the use of any product data, diagrams, charts, programs, algorithms, or circuit application examples contained in these materials.
3. All information contained in these materials, including product data, diagrams, charts, programs and algorithms represents information on products at the time of publication of these materials, and are subject to change by Renesas Technology Corporation without notice due to product improvements or other reasons. It is therefore recommended that customers contact Renesas Technology Corporation or an authorized Renesas Technology Corporation product distributor for the latest product information before purchasing a product listed herein.
The information described here may contain technical inaccuracies or typographical errors. Renesas Technology Corporation assumes no responsibility for any damage, liability, or other loss rising from these inaccuracies or errors.
Please also pay attention to information published by Renesas Technology Corporation by various means, including the Renesas Technology Corporation Semiconductor home page (<http://www.renesas.com>).
4. When using any or all of the information contained in these materials, including product data, diagrams, charts, programs, and algorithms, please be sure to evaluate all information as a total system before making a final decision on the applicability of the information and products. Renesas Technology Corporation assumes no responsibility for any damage, liability or other loss resulting from the information contained herein.
5. Renesas Technology Corporation semiconductors are not designed or manufactured for use in a device or system that is used under circumstances in which human life is potentially at stake. Please contact Renesas Technology Corporation or an authorized Renesas Technology Corporation product distributor when considering the use of a product contained herein for any specific purposes, such as apparatus or systems for transportation, vehicular, medical, aerospace, nuclear, or undersea repeater use.
6. The prior written approval of Renesas Technology Corporation is necessary to reprint or reproduce in whole or in part these materials.
7. If these products or technologies are subject to the Japanese export control restrictions, they must be exported under a license from the Japanese government and cannot be imported into a country other than the approved destination.
Any diversion or reexport contrary to the export control laws and regulations of Japan and/or the country of destination is prohibited.
8. Please contact Renesas Technology Corporation for further details on these materials or the products contained therein.

H8S/2160B Series Expansion I/O Board (HS2160EIO61H) for E6000 Emulator

User's Manual

The logo for Renesas, featuring a stylized 'R' followed by the word 'RENESAS' in a bold, sans-serif font.

ADE-702-311

Rev. 1.0

04/08/02

Hitachi, Ltd.

HS2160EIO61HE

Cautions

1. Hitachi neither warrants nor grants licenses of any rights of Hitachi's or any third party's patent, copyright, trademark, or other intellectual property rights for information contained in this document. Hitachi bears no responsibility for problems that may arise with third party's rights, including intellectual property rights, in connection with use of the information contained in this document.
2. Products and product specifications may be subject to change without notice. Confirm that you have received the latest product standards or specifications before final design, purchase or use.
3. Hitachi makes every attempt to ensure that its products are of high quality and reliability. However, contact Hitachi's sales office before using the product in an application that demands especially high quality and reliability or where its failure or malfunction may directly threaten human life or cause risk of bodily injury, such as aerospace, aeronautics, nuclear power, combustion control, transportation, traffic, safety equipment or medical equipment for life support.
4. Design your application so that the product is used within the ranges guaranteed by Hitachi particularly for maximum rating, operating supply voltage range, heat radiation characteristics, installation conditions and other characteristics. Hitachi bears no responsibility for failure or damage when used beyond the guaranteed ranges. Even within the guaranteed ranges, consider normally foreseeable failure rates or failure modes in semiconductor devices and employ systemic measures such as fail-safes, so that the equipment incorporating Hitachi product does not cause bodily injury, fire or other consequential damage due to operation of the Hitachi product.
5. This product is not designed to be radiation resistant.
6. No one is permitted to reproduce or duplicate, in any form, the whole or part of this document without written approval from Hitachi.
7. Contact Hitachi's sales office for any questions regarding this document or Hitachi semiconductor products.

IMPORTANT INFORMATION

READ FIRST

- **READ this user's manual before using this emulator product.**
- **KEEP the user's manual handy for future reference.**

Do not attempt to use the emulator product until you fully understand its mechanism.

Emulator Product:

Throughout this document, the term "emulator product" shall be defined as the following products produced only by Hitachi, Ltd. excluding all subsidiary products.

- E6000 series emulator station
- Expansion I/O board
- User system interface cables
- PC interface board

The user system or a host computer is not included in this definition.

Purpose of the Expansion I/O Board:

This expansion I/O board is installed in the E6000 emulator, and enables the emulator station to be connected to the user system interface cable. This expansion I/O board must only be used for the above purpose.

Improvement Policy:

Hitachi, Ltd. (including its subsidiaries, hereafter collectively referred to as Hitachi) pursues a policy of continuing improvement in design, functions, performance, and safety of the emulator product. Hitachi reserves the right to change, wholly or partially, the specifications, design, user's manual, and other documentation at any time without notice.

Target User of the Emulator Product:

This emulator product should only be used by those who have carefully read and thoroughly understood the information and restrictions contained in the user's manual. Do not attempt to use the emulator product until you fully understand its mechanism.

It is highly recommended that first-time users be instructed by users that are well versed in the operation of the emulator product.

LIMITED WARRANTY

Hitachi warrants its emulator products to be manufactured in accordance with published specifications and free from defects in material and/or workmanship. Hitachi, at its option, will repair or replace any emulator products returned intact to the factory, transportation charges prepaid, which Hitachi, upon inspection, determine to be defective in material and/or workmanship. The foregoing shall constitute the sole remedy for any breach of Hitachi's warranty. See the Hitachi warranty booklet for details on the warranty period. This warranty extends only to you, the original Purchaser. It is not transferable to anyone who subsequently purchases the emulator product from you. Hitachi is not liable for any claim made by a third party or made by you for a third party.

DISCLAIMER

HITACHI MAKES NO WARRANTIES, EITHER EXPRESS OR IMPLIED, ORAL OR WRITTEN, EXCEPT AS PROVIDED HEREIN, INCLUDING WITHOUT LIMITATION THEREOF, WARRANTIES AS TO MARKETABILITY, MERCHANTABILITY, FITNESS FOR ANY PARTICULAR PURPOSE OR USE, OR AGAINST INFRINGEMENT OF ANY PATENT. IN NO EVENT SHALL HITACHI BE LIABLE FOR ANY DIRECT, INCIDENTAL OR CONSEQUENTIAL DAMAGES OF ANY NATURE, OR LOSSES OR EXPENSES RESULTING FROM ANY DEFECTIVE EMULATOR PRODUCT, THE USE OF ANY EMULATOR PRODUCT, OR ITS DOCUMENTATION, EVEN IF ADVISED OF THE POSSIBILITY OF SUCH DAMAGES. EXCEPT AS EXPRESSLY STATED OTHERWISE IN THIS WARRANTY, THIS EMULATOR PRODUCT IS SOLD "AS IS", AND YOU MUST ASSUME ALL RISK FOR THE USE AND RESULTS OBTAINED FROM THE EMULATOR PRODUCT.

State Law:

Some states do not allow the exclusion or limitation of implied warranties or liability for incidental or consequential damages, so the above limitation or exclusion may not apply to you. This warranty gives you specific legal rights, and you may have other rights which may vary from state to state.

The Warranty is Void in the Following Cases:

Hitachi shall have no liability or legal responsibility for any problems caused by misuse, abuse, misapplication, neglect, improper handling, installation, repair or modifications of the emulator product without Hitachi's prior written consent or any problems caused by the user system.

All Rights Reserved:

This user's manual and emulator product are copyrighted and all rights are reserved by Hitachi. No part of this user's manual, all or part, may be reproduced or duplicated in any form, in hard-copy or machine-readable form, by any means available without Hitachi's prior written consent.

Other Important Things to Keep in Mind:

1. Circuitry and other examples described herein are meant merely to indicate the characteristics and performance of Hitachi's semiconductor products. Hitachi assumes no responsibility for any intellectual property claims or other problems that may result from applications based on the examples described herein.
2. No license is granted by implication or otherwise under any patents or other rights of any third party or Hitachi.

Figures:

Some figures in this user's manual may show items different from your actual system.

Limited Anticipation of Danger:

Hitachi cannot anticipate every possible circumstance that might involve a potential hazard. The warnings in this user's manual and on the emulator product are therefore not all inclusive. Therefore, you must use the emulator product safely at your own risk.

SAFETY PAGE

READ FIRST

- **READ** this user's manual before using this emulator product.
- **KEEP the user's manual handy for future reference.**

Do not attempt to use the emulator product until you fully understand its mechanism.

DEFINITION OF SIGNAL WORDS



This is the safety alert symbol. It is used to alert you to potential personal injury hazards. Obey all safety messages that follow this symbol to avoid possible injury or death.



DANGER indicates an imminently hazardous situation which, if not avoided, will result in death or serious injury.



WARNING indicates a potentially hazardous situation which, if not avoided, could result in death or serious injury.



CAUTION indicates a potentially hazardous situation which, if not avoided, may result in minor or moderate injury.



CAUTION used without the safety alert symbol indicates a potentially hazardous situation which, if not avoided, may result in property damage.

NOTE emphasizes essential information.

WARNING

Observe the precautions listed below. Failure to do so will result in a FIRE HAZARD and will damage the user system and the emulator product or will result in PERSONAL INJURY. The USER PROGRAM will be LOST.

- 1. Do not repair or remodel the emulator product by yourself for electric shock prevention and quality assurance.**
- 2. Always switch OFF the E6000 emulator and user system before connecting or disconnecting any CABLES or PARTS.**
- 3. Always before connecting any CABLES, make sure that pin 1 on both sides are correctly aligned.**
- 4. Supply power according to the power specifications and do not apply an incorrect power voltage. Use only the provided power cable.**

Preface

Thank you for purchasing this H8S/2160B series expansion I/O board (HS2160EIO61H; hereinafter referred to as the expansion I/O board) for the H8S series E6000 emulator.

The expansion I/O board enables user systems for Hitachi's original microcomputer H8S/2160 series to be developed using an H8S/2148B series E6000 emulator (HS2140EPI61H; hereinafter referred to as the emulator).

Contents

Section 1	Overview	1
1.1	Environment Conditions.....	1
1.2	Supported MCUs and User System Interface Cables	1
1.3	Operating Voltage and Frequency Specifications	2
1.4	Components	3
1.5	Opening the Case of Expansion I/O Board	4
Section 2	Connection Procedures	5
2.1	Using Emulator without Connecting User System	5
2.2	Using Emulator with Connecting User System through User System Interface Cable.....	6
Section 3	User System Interface	7
Section 4	Notice.....	11

Section 1 Overview

The H8S/2160 series E6000 expansion I/O board (hereinafter referred to as the expansion I/O board) is an efficient software and hardware development support tool for application systems using Hitachi's original microcomputers H8S/2160 series LPC (Low Pin Count) interface.

The expansion I/O board should be used with H8S/2148B series E6000 emulator station (HS2140EPI61H: hereinafter referred to as the emulator).

1.1 Environment Conditions

Table 1.1 Environment Conditions

Item	Specifications
Temperature	Operating: +10 to +35°C Storage: -10 to +50°C
Humidity	Operating: 35 to 80% RH; no condensation Storage: 35 to 80% RH; no condensation
Ambient gases	No corrosive gases
Power supply	Power supply from E6000 emulator station
User system voltage (UVcc)	Depends on the MCU within the range 2.7 V to 3.6 V

1.2 Supported MCUs and User System Interface Cables

Table 1.2 shows the correspondence between the MCUs and the user system interface cables supported by the E6000.

H8S/2160B Series:

Table 1.2 H8S/2160B Series MCUs and User System Interface Cable

No.	MCU Type Number	Package	E6000 User System Interface Cables
1	HD64F2160B HD64F2161B	144-pin TQFP(TFP-144)	HS2169ECN61H

1.3 Operating Voltage and Frequency Specifications

Table 1.3 shows the MCU operating voltage and frequency specifications supported by the E6000. If the E6000 is used in an environment that exceeds the operating voltage range and operating frequency range guaranteed for the MCU operation, normal emulator operation is not guaranteed.

Table 1.3 Operating Voltage and Frequency Specifications

No.	MCU Types	Operating Voltage (V)	Operating Frequency (ϕ) (MHz)
1	H8S/2160B series	2.7-3.6	2-10

NOTE

For details on the operating voltage and frequency specifications, refer to the MCU hardware manual.

1.4 Components

Figure 1.1 shows the HS2160EIO61H expansion I/O board appearance, and table 1.4 lists the components of the expansion I/O board. Please make sure you have all of these components when unpacking.

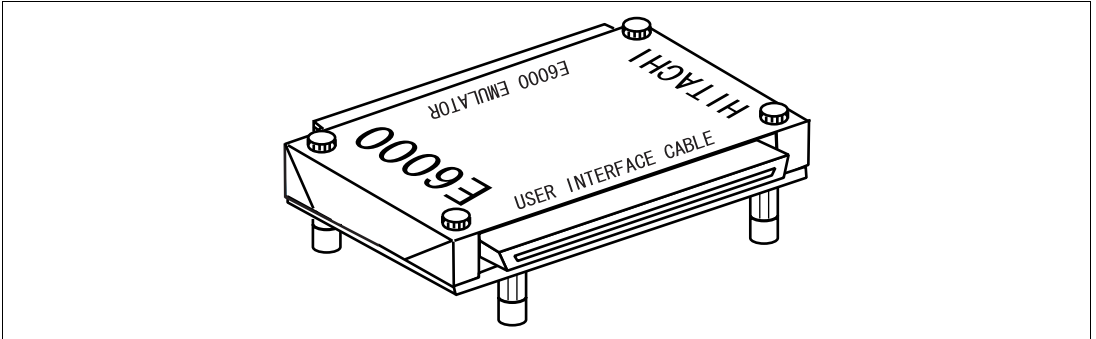

Figure 1.1 HS2160EIO61H Expansion I/O Board

Table 1.4 HS2160EIO61H Components

No.	Component	Quantity	Remarks
1	HS2160EIO61H	1	Expansion I/O board
2	Documentation	1	User's manual for HS2160EIO61H (this manual)

1.5 Opening the Case of Expansion I/O Board

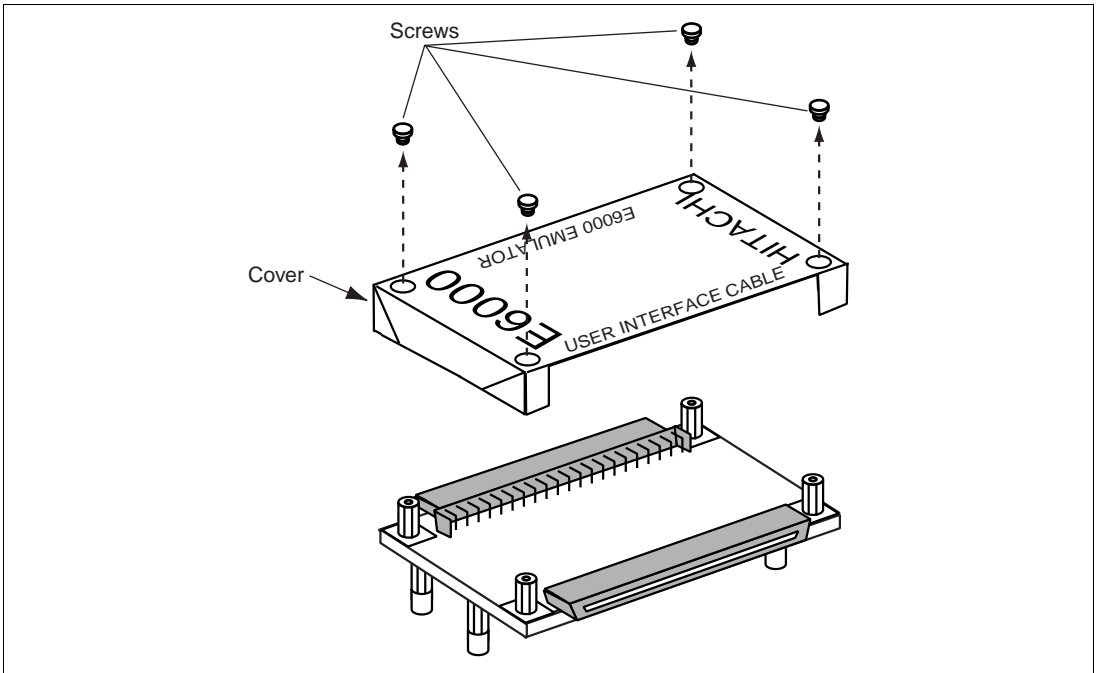

Figure 1.2 Opening the Case of the Expansion I/O Board

To open the case of the expansion I/O board, remove the four screws on the cover. To close the case, place the cover on the expansion I/O board, and fix it with the four screws.

To prevent breaking of wires in the expansion I/O board, do not place heavy or sharp metal objects on the expansion I/O board while the case is open.

Section 2 Connection Procedures

WARNING

Always switch OFF the user system and the emulator product before the EXPANSION I/O BOARD or USER SYSTEM INTERFACE CABLE is connected to or removed from any part. Before connecting, make sure that pin 1 on each side is correctly aligned. Failure to do so will result in a FIRE HAZARD and will damage the user system, the emulator product, the user system interface cable, and the expansion board, or will result in PERSONAL INJURY. The USER PROGRAM will be LOST.

2.1 Using Emulator without Connecting User System

1. Make sure the emulator is turned off.
2. After making sure the direction of the expansion I/O board connector labeled E6000 EMULATOR is correct, firmly insert the expansion I/O board connector into the emulator station connector. When the emulator is operated while connected to only the expansion I/O board (without connecting the user system), disconnect the cable body from the expansion I/O board.

2.2 Using Emulator with Connecting User System through User System Interface Cable

CAUTION

When connecting or removing the user system interface cable, apply force only in the direction suitable for connection or removal, while making sure not to bend or twist the cable or connectors.

Otherwise, the cables or connectors will be damaged.

1. Make sure the emulator and the user system are turned off.
2. [1] After making sure the direction of the expansion I/O board connector labeled E6000 EMULATOR is correct, firmly insert the expansion I/O board connector into the emulator station connector ([1] in figure 2.1).
[2] To connect the expansion I/O board labeled USER INTERFACE CABLE and the user system interface cable body.

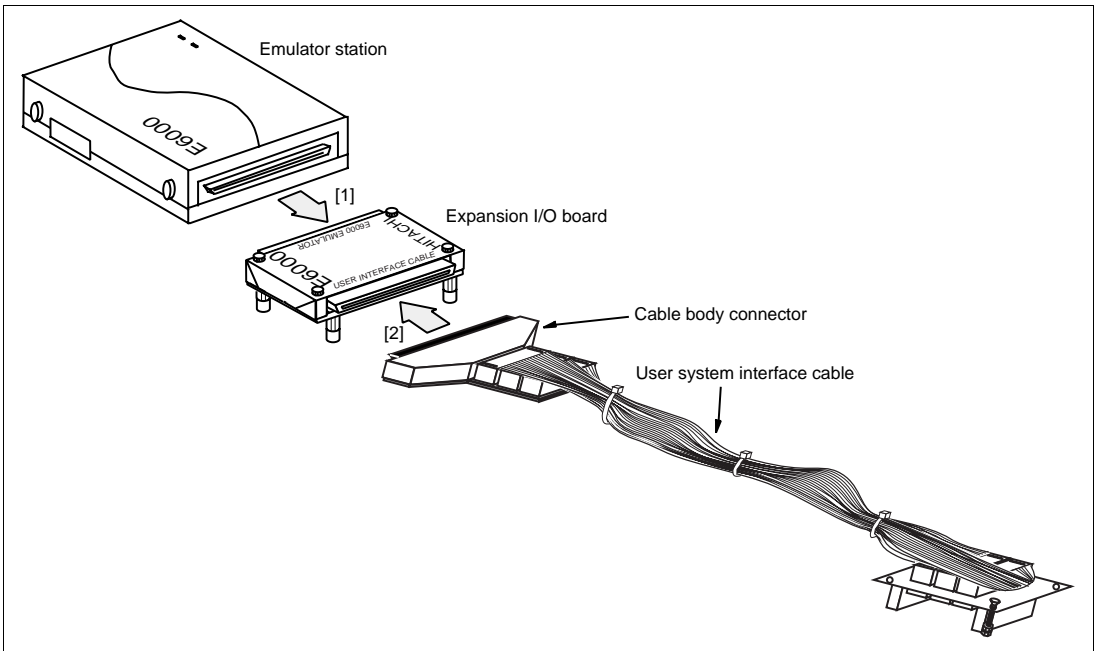

Figure 2.1 Connecting Expansion I/O Board to Emulator Station and User System Interface Cable

Section 3 User System Interface

Switches, protection circuits, and termination circuits are provided for the H8S/2160B LPC interface of the expansion I/O board. Signals are connected to the user system interface cable with the protection circuit. Figure 3.1 and Figure 3.2 shows user interface circuit.

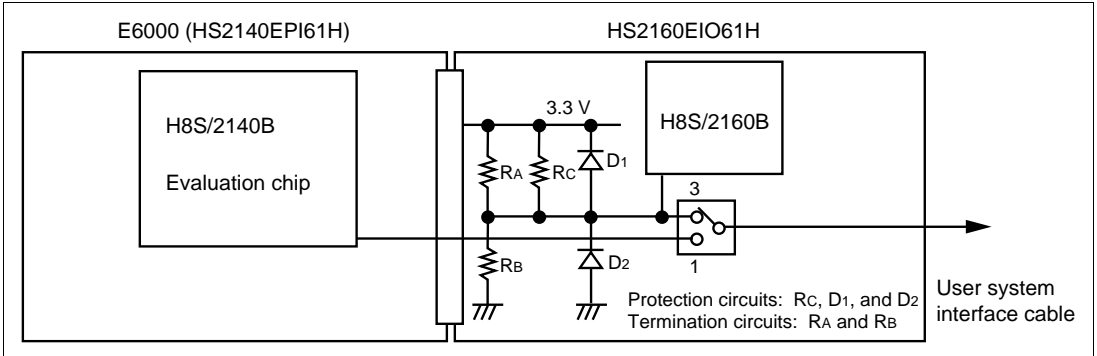

Figure 3.1 User System Interface Circuit

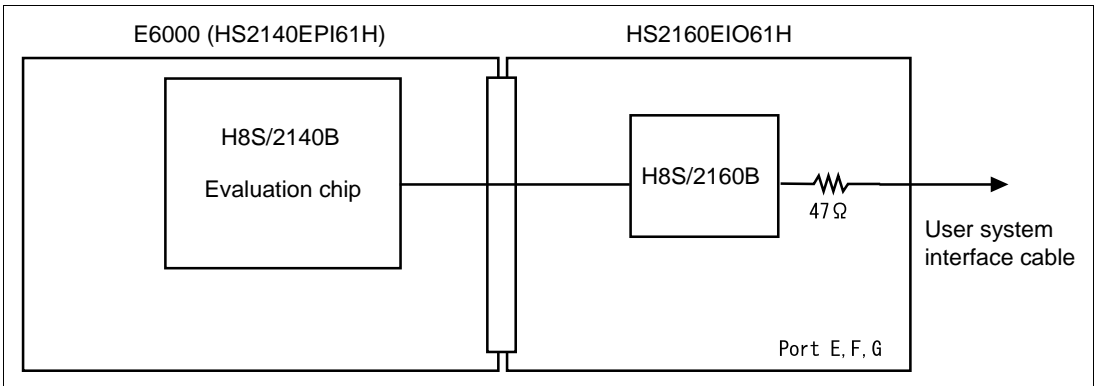

Figure 3.2 User System Interface Circuit (Port E,F,G)

Table 3.1 shows switches and circuit description.

Table 3.1 User System Interface Description

No.	Signals	Switch	Termination circuit R _A	Termination circuit R _B	Protection circuits R _C , D ₁ , D ₂	Notes
1	LAD0	SW7 side 3	Pull-up (R1)	Pull-down (R2)	R _C is 47 k ohm (N40,N41) D ₁ , and D ₂ are not connected.	SW7 side 1 is port 30
2	LAD1	SW8 side 3	Pull-up (R3)	Pull-down (R4)		SW8 side 1 is port 31
3	LAD2	SW9 side 3	Pull-up (R5)	Pull-down (R6)		SW9 side 1 is port 32
4	LAD3	SW10 side 3	Pull-up (R7)	Pull-down (R8)		SW10 side 1 is port 33
5	LFRAMEN	SW11 side 3	Pull-up (R9)	Pull-down (R10)		SW11 side 1 is port 34
6	LRESETN	SW12 side 3	Pull-up (R11)	Pull-down (R12)		SW12 side 1 is port 35
7	LCLK	SW13 side 3	Pull-up (R13)	Pull-down (R14)		SW13 side 1 is port 36
8	SERIRQ	SW14 side 3	Pull-up (R15)	Pull-down (R16)		SW14 side 1 is port 37
9	WUEN0	SW15 side 3	47 k ohm (N1) Pull-up	None	R _C is not connected. D ₁ , and D ₂ are connected (must not be removed).	SW15 side 1 is port B0
10	WUEN1	SW16 side 3				SW16 side 1 is port B1
11	WUEN2	SW17 side 3				SW17 side 1 is port B2
12	WUEN3	SW18 side 3				SW18 side 1 is port B3
13	WUEN4	SW19 side 3				SW19 side 1 is port B4
14	WUEN5	SW20 side 3				SW20 side 1 is port B5
15	WUEN6	SW21 side 3				SW21 side 1 is port B6
16	WUEN7	SW22 side 3				SW22 side 1 is port B7
17	PMEN	SW23 side 3	47 k ohm (N2) Pull-up			SW23 side 1 is port 80
18	GA20	SW24 side 3				SW24 side 1 is port 81
19	CLKRUNN	SW25 side 3				SW25 side 1 is port 82
20	LPCPDN	SW26 side 3				SW26 side 1 is port 83

Note: N1 and N2 are installed in a pin socket so that they can be removed by the user.

Pin sockets are mounted on the expansion I/O board so that resistors can be mounted on R1 to R16 by the user. Resistors are not mounted on R1 to R16 at shipment.

CAUTION

SW6 has a different circuit structure compared to other switches.

Side 3: When using WUEN7 as an IRQ7 interrupt, set SW6 to side 3. In this case, be aware that the PA1 pin function cannot be used.

Side 1: PA1 pin function can be used. In the case, be aware that WUEN7 cannot be used as an IRQ interrupt.

Figure 3.3 shows location of switches and resistor.

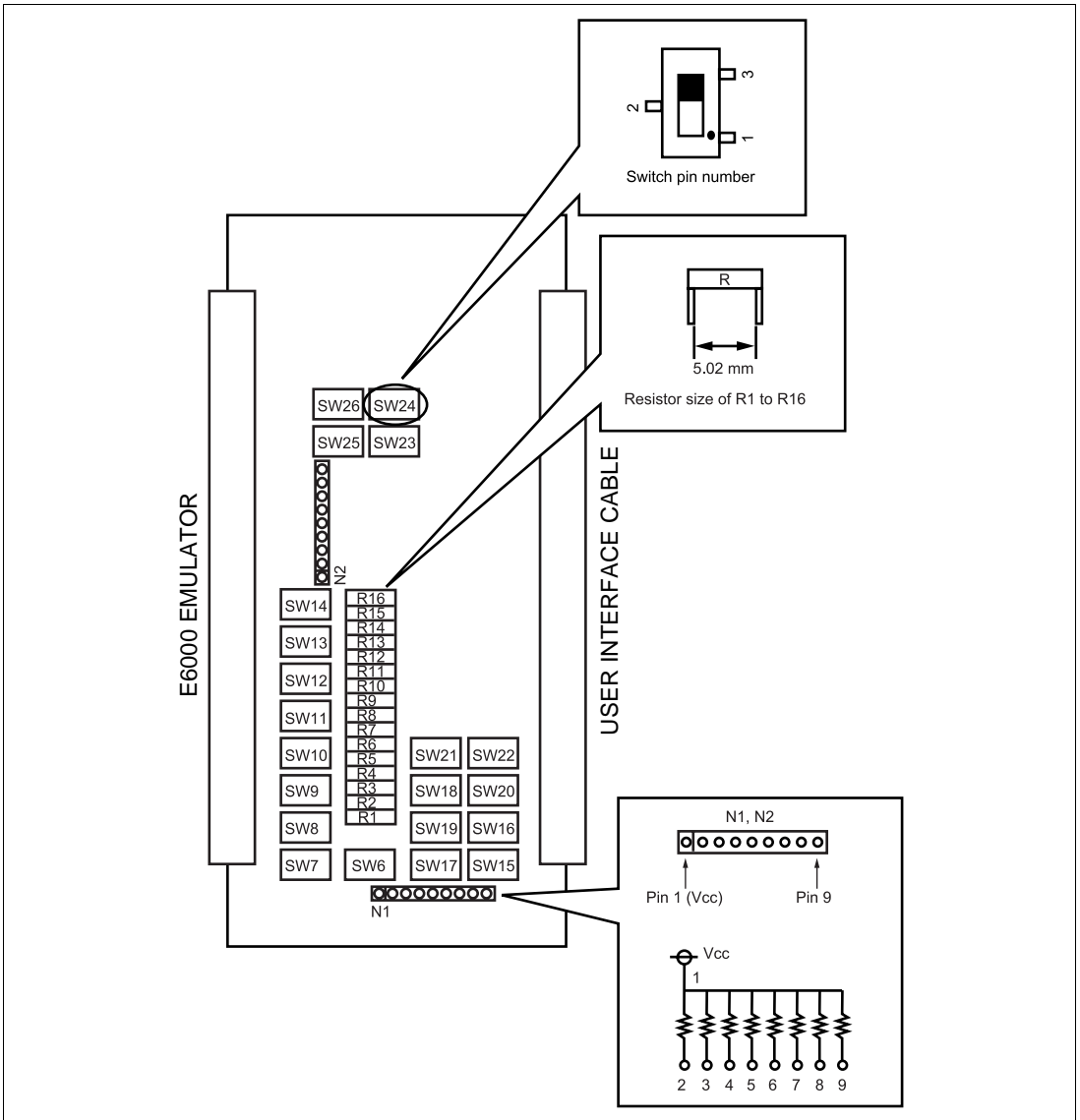

Figure 3.3 Location of Switches and Resistor

Section 4 Notice

WARNING

Observe the precautions listed below. Failure to do so will result in a FIRE HAZARD and will damage the user system and the emulator product or will result in PERSONAL INJURY. The USER PROGRAM will be LOST.

- 1. This expansion I/O board is specifically designed for the HS2140EPI61H. Do not use this expansion I/O board with any other emulator station.**
- 2. Use the H8S/2160B and H8S/2169 series user system interface cable (HS2169ECN61H for TFP-144). Do not use any other series of user system interface cable.**

1. Do not place heavy objects on the expansion I/O board.
2. Power is supplied from the emulator station to the expansion I/O board.
3. LPC Module and Ports C to G Reset Specifications

For **the reset function of the LPC module and ports C, D, E, F, and G**, note that there are differences between the H8S/2160B series E6000 expansion I/O board and the target MCU.

The reset conditions for the CPU and other modules than the LPC and ports C, D, E, F, and G have no differences.

Reset Type	Internal Reset by WDT Overflow	Go RESET, CPU RESET Commands	Reset Signal Input of Target System
E6000 expansion I/O board	Reset enabled	Reset disabled	Reset enabled*
Target MCU	Reset enabled	—	Reset enabled

Note: RESET signal from the target board to the evaluation chip can be masked by setting RESET MASK check box in Configuration window of HDI. But reset signal for the LPC module and ports C, D, E, F, and G are always enabled when RESET MASK in Configuration of the HDI is either enabled or disabled. When user debugs target system with the expansion I/O board, disable RESET MASK and always input RESET signal from the target system.