

HA17902 Series

Quad Operational Amplifier

REJ03D0685-0100
(Previous: ADE-204-045)
Rev.1.00
Jun 15, 2005

Description

The HA17902 is an internal phase compensation quad operational amplifier that operates on a single-voltage power supply and is appropriate for use in a wide range of general-purpose control equipment.

Features

- Wide usable power-supply voltage range and single-voltage supply operation
- Internal phase compensation
- Wide common-mode voltage range and operation for inputs close to the 0 level

Ordering Information

Type No.	Application	Package Code (Previous Code)
HA17902PJ	Car use	PRDP0014AB-A (DP-14)
HA17902FPJ		PRSP0014DF-B (FP-14DAV)
HA17902FPK		PRSP0014DF-B (FP-14DAV)

Not recommended
for new designs

Pin Arrangement

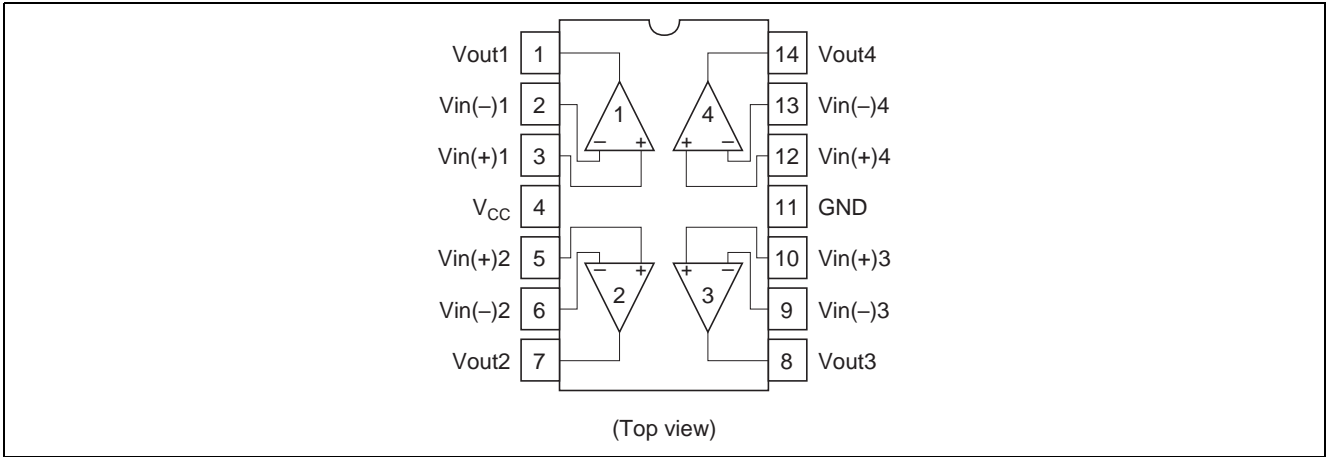

Circuit Structure (1/4)

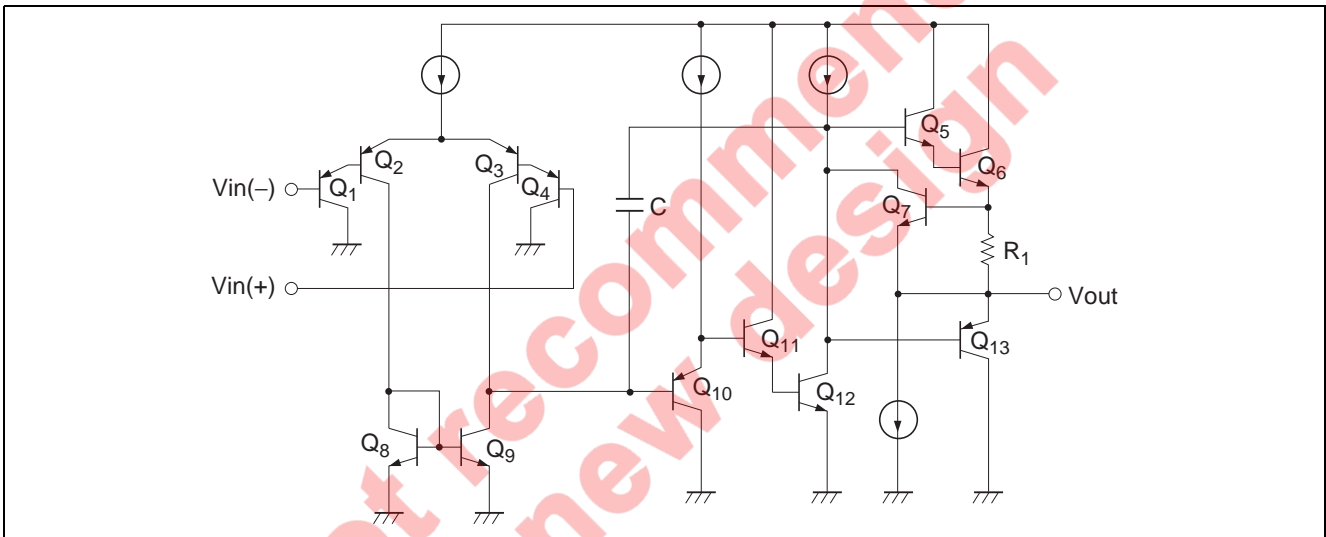

Absolute Maximum Ratings

(Ta = 25°C)

Item	Symbol	HA17902PJ	HA17902 FPJ	HA17902FPK	Unit
Power supply voltage	V _{CC}	28	28	28	V
Sink current	I _{o sink}	50	50	25	mA
Allowable power dissipation	P _T	625* ¹	625* ²	625* ²	mW
Common-mode input voltage	V _{CM}	-0.3 to V _{CC}	-0.3 to V _{CC}	-0.3 to V _{CC}	V
Differential-mode input voltage	V _{in(diff)}	±V _{CC}	±V _{CC}	±V _{CC}	V
Operating temperature	Topr	-40 to +85	-40 to +85	-40 to +125	°C
Storage temperature	Tstg	-55 to +125	-55 to +125	-55 to +150	°C

Notes: 1. These are the allowable values up to Ta = 50°C. Derate by 8.3mW/°C above that temperature.

2. See notes on SOP Package Usage in Reliability section.

Electrical Characteristics 1

(V_{CC} = +15V, Ta = 25°C)

Item	Symbol	Min	Typ	Max	Unit	Test Conditions
Input offset voltage	V _{IO}	—	3	8	mV	V _{CM} = 7.5V, R _S = 50Ω, R _f = 5kΩ
Input offset current	I _{IO}	—	5	50	nA	I _{IO} = I _{I-} - I _{I+} , V _{CM} = 7.5V
Input bias current	I _{IB}	—	30	500	nA	V _{CM} = 7.5V
Power-supply rejection ratio	PSRR	—	93	—	dB	f = 100Hz, R _S = 1kΩ, R _f = 100kΩ
Voltage gain	A _{VD}	75	90	—	dB	R _S = 1kΩ, R _f = 100kΩ, R _L = ∞
Common-mode rejection ratio	CMR	—	80	—	dB	R _S = 50Ω, R _f = 5kΩ
Common-mode input voltage range	V _{CM}	-0.3	—	13.5	V	R _S = 1kΩ, R _f = 100kΩ, f = 100Hz
Maximum output voltage amplitude	V _{OP-P}	—	13.6	—	V	f = 100Hz, R _S = 1kΩ, R _f = 100kΩ, R _L = 20kΩ
Output voltage	V _{OH1}	13.2	13.6	—	V	I _{OH} = -1mA
	V _{OH2}	12	13.3	—	V	I _{OH} = -10mA
	V _{OL1}	—	0.8	1	V	I _{OL} = 1mA
	V _{OL2}	—	1.1	1.8	V	I _{OL} = 10mA
Output source current	I _{o source}	15	—	—	mA	V _{OH} = 10V
Output sink current	I _{o sink}	3	9	—	mA	V _{OL} = 1V
Supply current	I _{CC}	—	0.8	2	mA	V _{in} = GND, R _L = ∞
Slew rate	SR	—	0.19	—	V/μs	f = 1.5kHz, V _{CM} = 7.5V, R _L = ∞
Channel separation	CS	—	120	—	dB	f = 1kHz

Electrical Characteristics 2

(V_{CC} = +15V, Ta = -40 to 125°C)

Item	Symbol	Min	Typ	Max	Unit	Test Conditions
Input offset voltage	V _{IO}	—	—	8	mV	V _{CM} = 7.5V, R _S = 50Ω, R _f = 5kΩ
Input offset current	I _{IO}	—	—	200	nA	V _{CM} = 7.5V, I _{IO} = I _{I-} - I _{I+}
Input bias current	I _{IB}	—	—	500	nA	V _{CM} = 7.5V
Common-mode input voltage range	V _{CM}	0	—	13.0	V	R _S = 1kΩ, R _f = 100kΩ, f = 100Hz
Output voltage	V _{OH}	13.0	—	—	V	I _{OH} = -1mA
	V _{OL}	—	—	1.3	V	I _{OL} = 1mA
Supply current	I _{CC}	—	—	4	mA	V _{in} = GND, R _L = ∞

Test Circuits

1. Input offset voltage (V_{IO}), input offset current (I_{IO}), and Input bias current (I_{IB}) test circuit

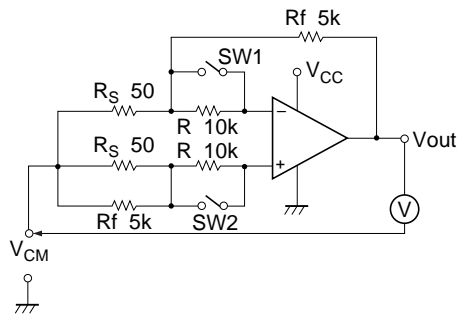

SW1	SW2	V_O
On	On	V_{O1}
Off	Off	V_{O2}
On	Off	V_{O3}
Off	On	V_{O4}

$$V_{CM} = \frac{1}{2} V_{CC}$$

$$V_{IO} = \frac{V_{O1}}{1 + R_f / R_s} \quad (\text{mV})$$

$$I_{IO} = \frac{V_{O2} - V_{O1}}{R(1 + R_f / R_s)} \quad (\text{nA})$$

$$I_{IB} = \frac{|V_{O4} - V_{O3}|}{2 \cdot R(1 + R_f / R_s)} \quad (\text{nA})$$

2. Common-mode rejection ratio (CMR) test circuit

$$\text{CMR} = 20 \log \frac{V_{IN} \cdot R_f}{V_O \cdot R_s} \quad (\text{dB})$$

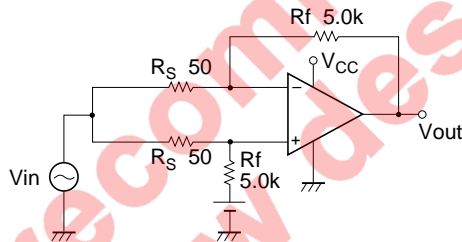

3. Supply current (I_{CC}) test circuit

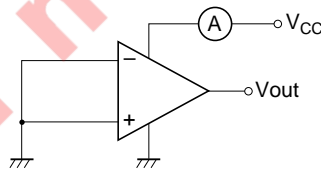

4. Voltage gain (A_{VD}), slew rate (SR), common-mode input voltage range (V_{CM}), and maximum output voltage amplitude (V_{OP-P}) test circuit.

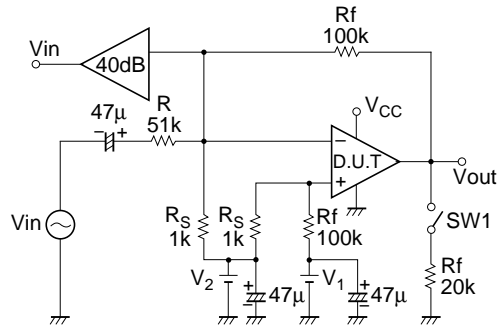

- (1) A_{VD} : $R_S = 1k\Omega$, $R_f = 100k\Omega$, $R_L = \infty$, $V_1 = V_2 = 1/2 V_{CC}$

$$A_{VD} = 20 \log \frac{V_O}{V_{IN}} + 40 \quad (\text{dB})$$

- (2) SR: $f = 1.5\text{kHz}$, $R_L = \infty$, $V_1 = V_2 = 1/2 V_{CC}$

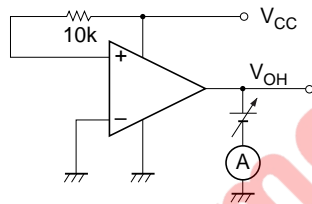

- (3) V_{CM} : $R_S = 1k\Omega$, $R_f = 100k\Omega$, $f = 100\text{Hz}$, $V_1 = 1/2 V_{CC}$, $R_L = \infty$, and the value of V_2 just slightly prior to the point where the output waveform changes.
 (4) V_{OP-P} : $R_S = 1k\Omega$, $R_f = 100k\Omega$, $R_L: 20k\Omega$, $f = 100\text{Hz}$, $V_{OP-P} = V_{OH} \leftrightarrow V_{OL} [V_{P-P}]$

5. Output source current (I_{source}) test circuit

$I_{o \text{ source}}$: $V_{OH} = 10V$

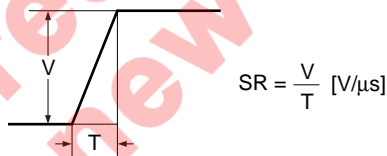

6. Output sink current (I_{sink}) test circuit

$I_{o \text{ sink}}$: $V_{OL} = 1V$

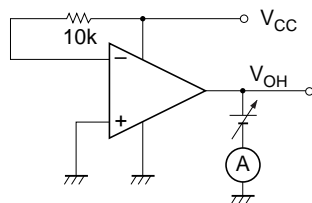

Characteristics Curve

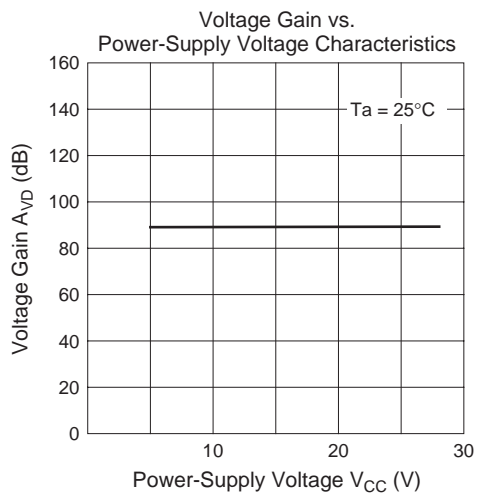
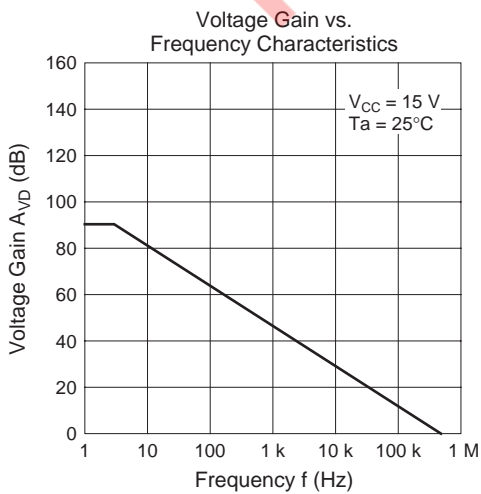
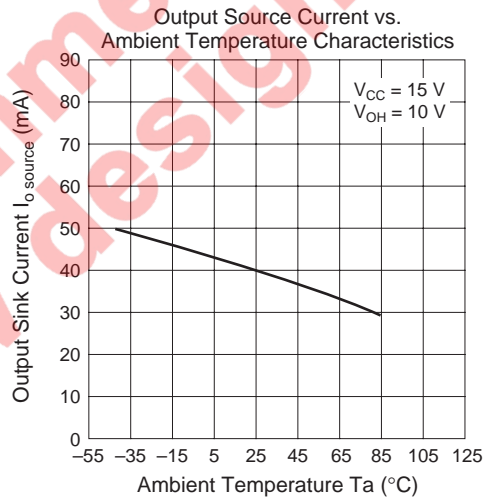
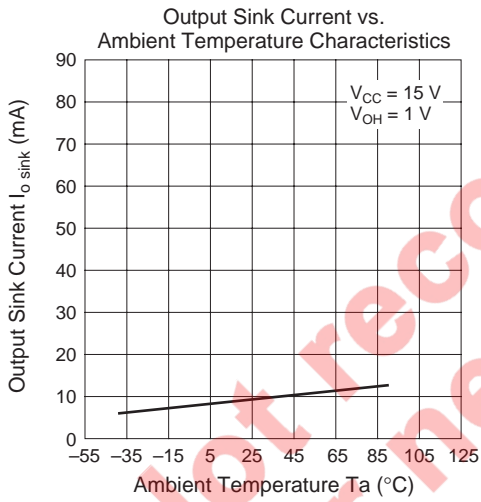
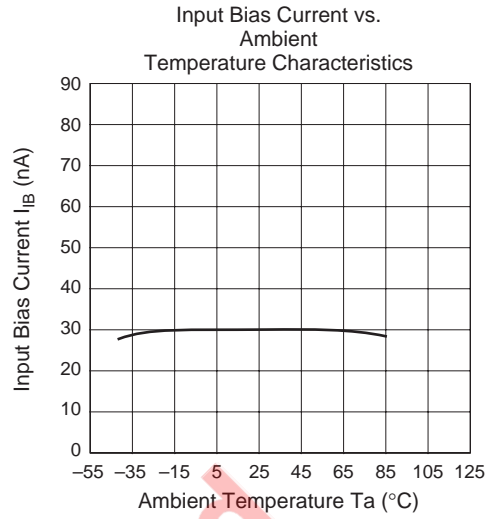
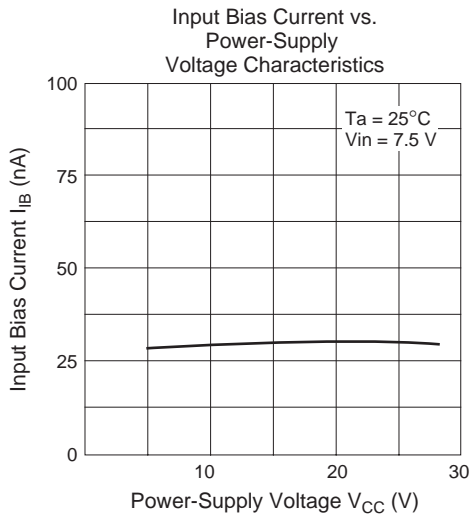

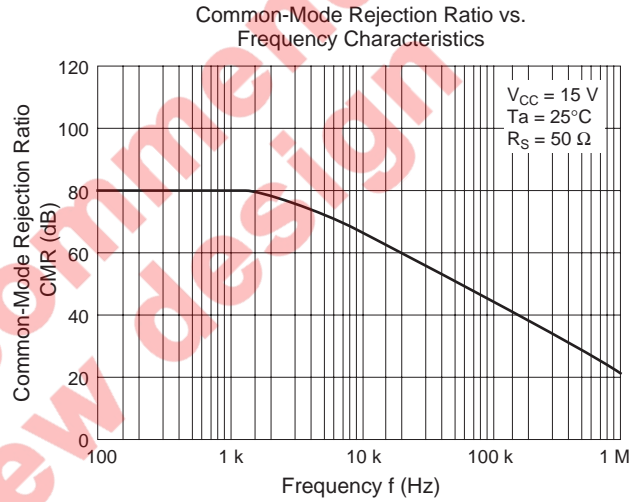
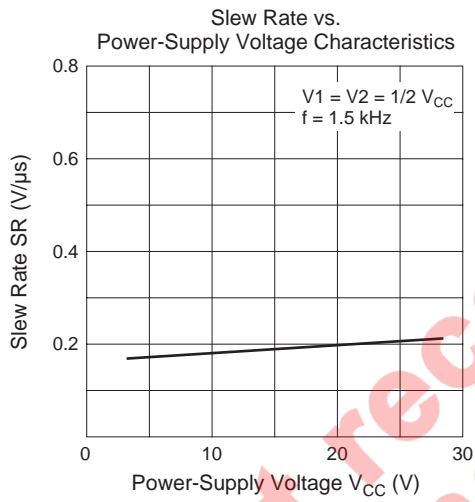
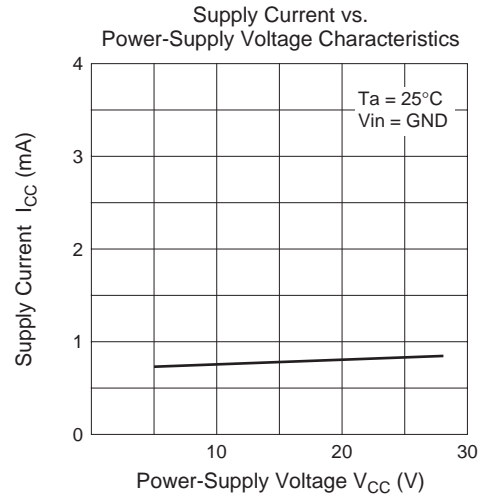
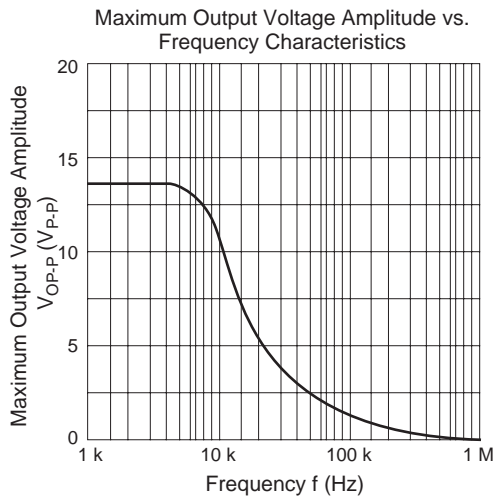

Not recommended for new design

HA17902 Application Examples

The HA17902 is a quad operational amplifier, and consists of four operational amplifier circuits and one bias current circuit. It features single-voltage power supply operation, internal phase compensation, a wide zero-cross bandwidth, a low input bias current, and a high open-loop gain. Thus the HA17902 can be used in a wide range of applications. This section describes several applications using the HA17902.

1. Noninverting Amplifier

Figure 1 shows the circuit diagram for a noninverting amplifier. The voltage gain of this amplifier is given by the following formula.

$$\frac{V_{out}}{V_{in}} = 1 + \frac{R_2}{R_1}$$

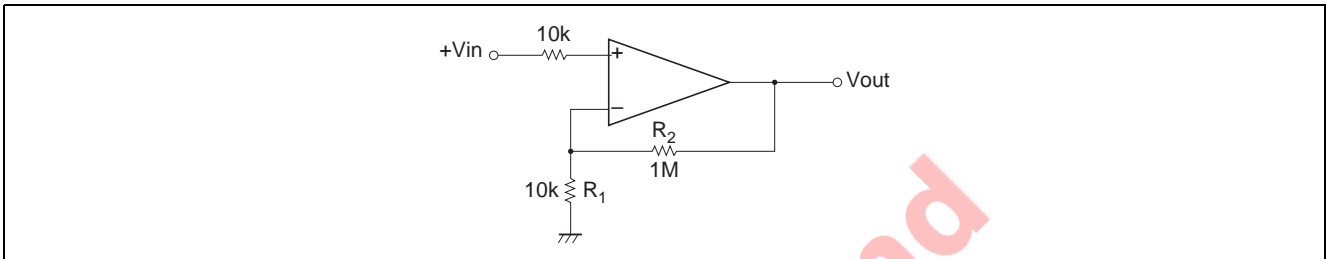

Figure 1 Noninverting Amplifier

2. Summing Amplifier

Since the circuit shown in figure 2 applies $+V_1$ and $+V_2$ to the noninverting input and $+V_3$ and $+V_4$ to the inverting input, the total output will be $V_{out} = V_1 + V_2 - V_3 - V_4$.

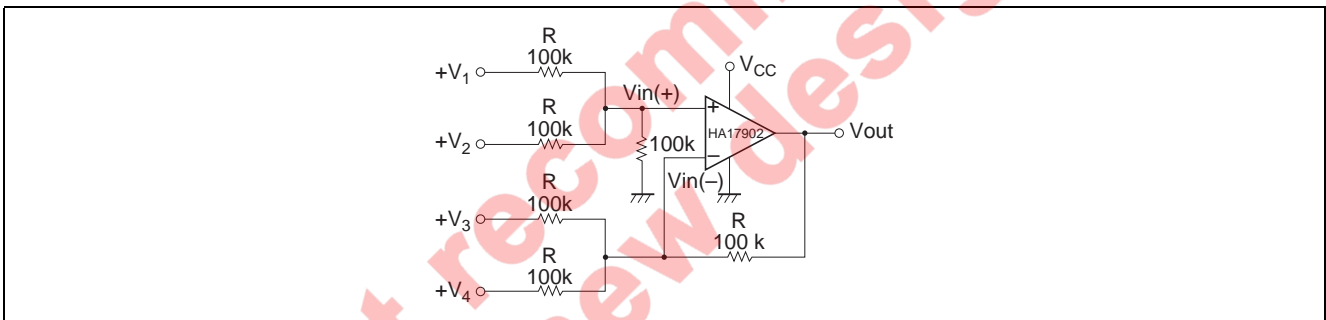

Figure 2 Summing Amplifier

3. High Input Impedance DC Differential Amplifier

The circuit shown in figure 3 is a high input impedance DC differential amplifier. This circuit's common-mode rejection ratio (CMR) depends on the matching between the R_1/R_2 and R_4/R_3 resistance ratios. This amplifier's output is given by the following formula.

$$V_{out} = \left(1 + \frac{R_4}{R_3}\right) (V_2 - V_1)$$

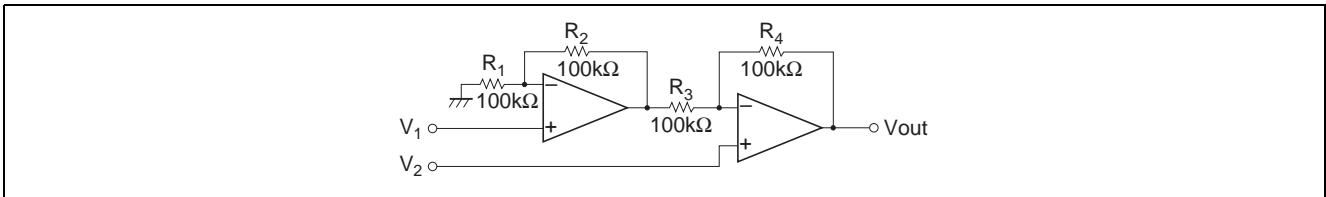

Figure 3 High Input Impedance DC Differential Amplifier

4. Voltage Controlled Oscillator

Figure 4 shows an oscillator circuit in which the amplifier A_1 is an integrator, the amplifier A_2 is a comparator, and transistor Q_1 operates as a switch that controls the oscillator frequency. If the output V_{out1} is at the low level, this will cut off transistor Q_1 and cause the A_1 inverting input to go to a higher potential than the noninverting input. Therefore, A_1 will integrate this negative input state and its output level will decrease. When the A_1 integrator output becomes lower than the A_2 comparator noninverting input level ($V_{CC}/2$) the comparator output goes high. This turns on transistor Q_1 causing the integrator to integrate a positive input state and for its output to increase. This operation generates a square wave on V_{out1} and a triangular wave on V_{out2} .

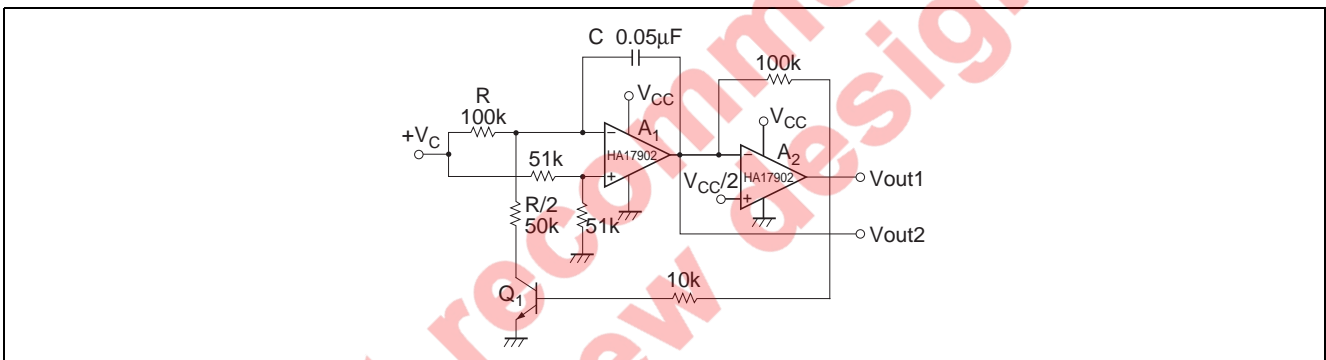
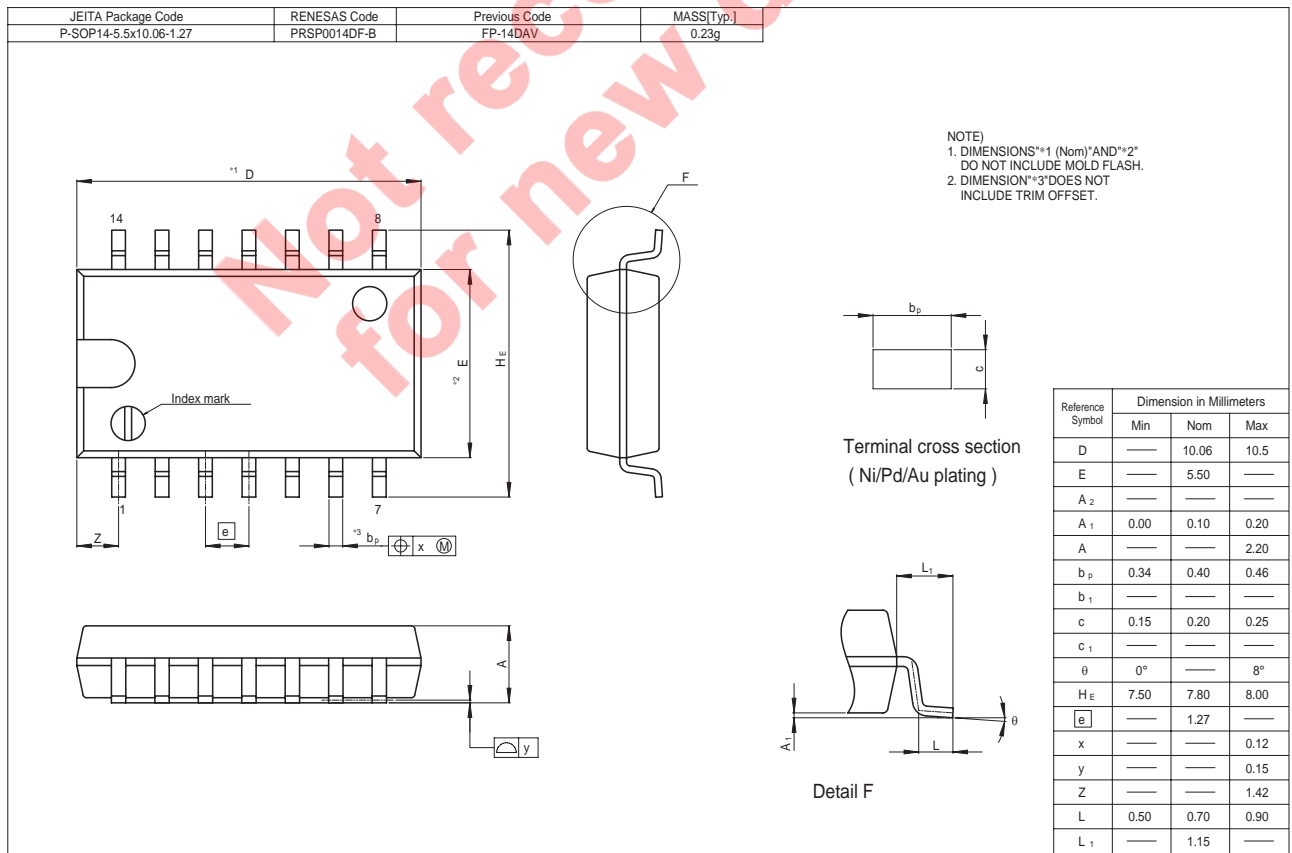
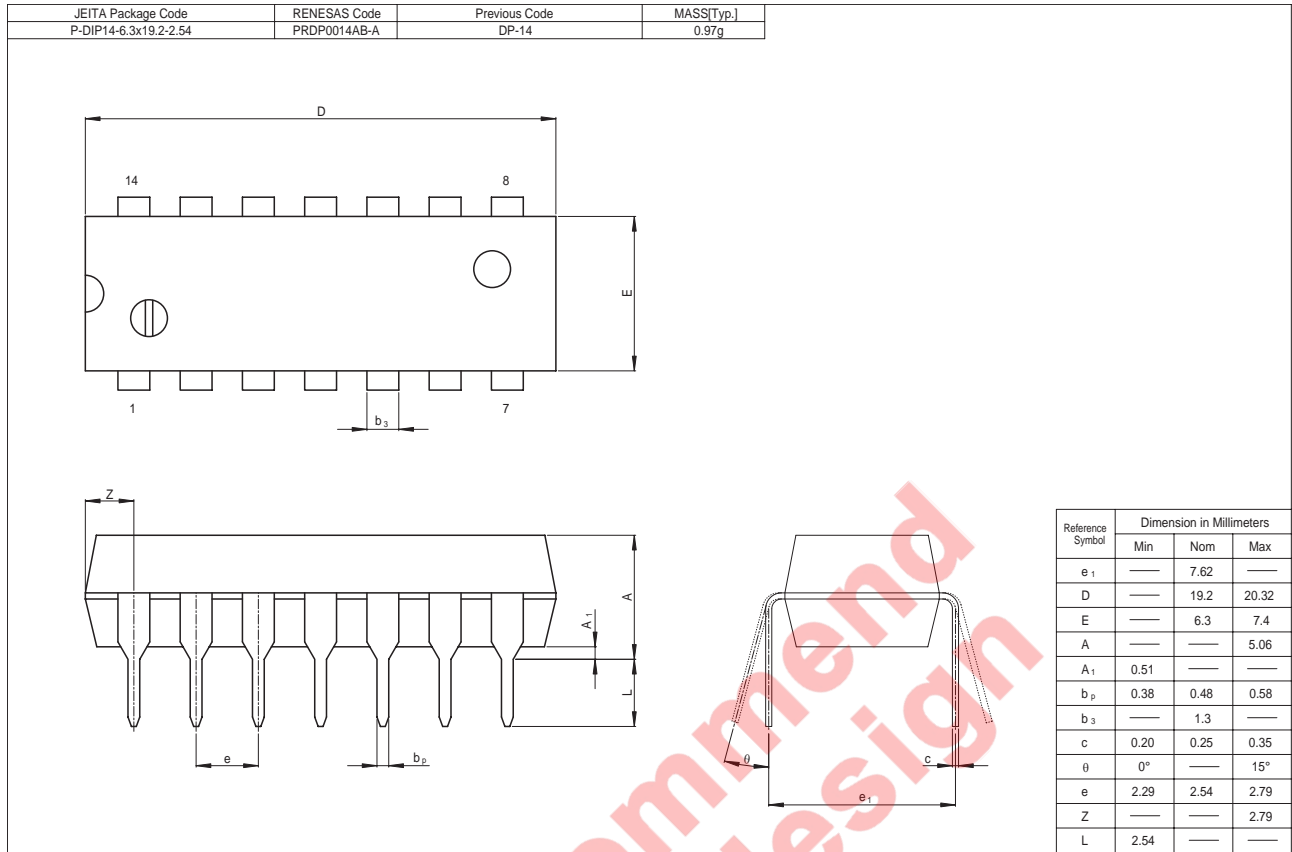

Figure 4 Voltage Controlled Oscillator

Package Dimensions



Renesas Technology Corp. Sales Strategic Planning Div. Nippon Bldg., 2-6-2, Ohte-machi, Chiyoda-ku, Tokyo 100-0004, Japan

Keep safety first in your circuit designs!

1. Renesas Technology Corp. puts the maximum effort into making semiconductor products better and more reliable, but there is always the possibility that trouble may occur with them. Trouble with semiconductors may lead to personal injury, fire or property damage.
Remember to give due consideration to safety when making your circuit designs, with appropriate measures such as (i) placement of substitutive, auxiliary circuits, (ii) use of nonflammable material or (iii) prevention against any malfunction or mishap.

Notes regarding these materials

1. These materials are intended as a reference to assist our customers in the selection of the Renesas Technology Corp. product best suited to the customer's application; they do not convey any license under any intellectual property rights, or any other rights, belonging to Renesas Technology Corp. or a third party.
 2. Renesas Technology Corp. assumes no responsibility for any damage, or infringement of any third-party's rights, originating in the use of any product data, diagrams, charts, programs, algorithms, or circuit application examples contained in these materials.
 3. All information contained in these materials, including product data, diagrams, charts, programs and algorithms represents information on products at the time of publication of these materials, and are subject to change by Renesas Technology Corp. without notice due to product improvements or other reasons. It is therefore recommended that customers contact Renesas Technology Corp. or an authorized Renesas Technology Corp. product distributor for the latest product information before purchasing a product listed herein.
The information described here may contain technical inaccuracies or typographical errors.
Renesas Technology Corp. assumes no responsibility for any damage, liability, or other loss rising from these inaccuracies or errors.
Please also pay attention to information published by Renesas Technology Corp. by various means, including the Renesas Technology Corp. Semiconductor home page (<http://www.renesas.com>).
 4. When using any or all of the information contained in these materials, including product data, diagrams, charts, programs, and algorithms, please be sure to evaluate all information as a total system before making a final decision on the applicability of the information and products. Renesas Technology Corp. assumes no responsibility for any damage, liability or other loss resulting from the information contained herein.
 5. Renesas Technology Corp. semiconductors are not designed or manufactured for use in a device or system that is used under circumstances in which human life is potentially at stake. Please contact Renesas Technology Corp. or an authorized Renesas Technology Corp. product distributor when considering the use of a product contained herein for any specific purposes, such as apparatus or systems for transportation, vehicular, medical, aerospace, nuclear, or undersea repeater use.
 6. The prior written approval of Renesas Technology Corp. is necessary to reprint or reproduce in whole or in part these materials.
 7. If these products or technologies are subject to the Japanese export control restrictions, they must be exported under a license from the Japanese government and cannot be imported into a country other than the approved destination.
Any diversion or reexport contrary to the export control laws and regulations of Japan and/or the country of destination is prohibited.
 8. Please contact Renesas Technology Corp. for further details on these materials or the products contained therein.
-

RENESAS SALES OFFICES



<http://www.renesas.com>

Refer to "<http://www.renesas.com/en/network>" for the latest and detailed information.

Renesas Technology America, Inc.
450 Holger Way, San Jose, CA 95134-1368, U.S.A
Tel: <1> (408) 382-7500, Fax: <1> (408) 382-7501

Renesas Technology Europe Limited
Dukes Meadow, Millboard Road, Bourne End, Buckinghamshire, SL8 5FH, U.K.
Tel: <44> (1628) 585-100, Fax: <44> (1628) 585-900

Renesas Technology Hong Kong Ltd.
7th Floor, North Tower, World Finance Centre, Harbour City, 1 Canton Road, Tsimshatsui, Kowloon, Hong Kong
Tel: <852> 2265-6688, Fax: <852> 2730-6071

Renesas Technology Taiwan Co., Ltd.
10th Floor, No.99, Fushing North Road, Taipei, Taiwan
Tel: <886> (2) 2715-2888, Fax: <886> (2) 2713-2999

Renesas Technology (Shanghai) Co., Ltd.
Unit2607 Ruijing Building, No.205 Maoming Road (S), Shanghai 200020, China
Tel: <86> (21) 6472-1001, Fax: <86> (21) 6415-2952

Renesas Technology Singapore Pte. Ltd.
1 Harbour Front Avenue, #06-10, Keppel Bay Tower, Singapore 098632
Tel: <65> 6213-0200, Fax: <65> 6278-8001