

# SG6741A — Highly Integrated Green-Mode PWM Controller

## Features

- High-voltage Startup
- Low Operating Current: 4mA
- Linearly Decreasing PWM Frequency to 18kHz
- Frequency Hopping to Reduce EMI Emissions
- Peak-current-mode Control
- Cycle-by-cycle Current Limiting
- Leading-edge Blanking (LEB)
- Synchronized Slope Compensation
- GATE Output Maximum Voltage Clamp: 18V
- V<sub>DD</sub> Over-voltage Protection (Auto Restart)
- V<sub>DD</sub> Under-voltage Lockout (UVLO)
- Internal Open-loop Protection
- Constant Power Limit (Full AC Input Range)

## Applications

General-purpose switch-mode power supplies and flyback power converters, including:

- Power Adapters
- Open-Frame SMPS

## Description

The highly integrated SG6741A series of PWM controllers provides several features to enhance the performance of flyback converters.

To minimize standby power consumption, a proprietary green-mode function provides off-time modulation to linearly decrease the switching frequency at light-load conditions. To avoid acoustic-noise problems, the minimum PWM frequency is set above 18KHz. This green-mode function enables the power supply to meet international power conservation requirements. With the internal high-voltage startup circuitry, the power loss due to bleeding resistors is eliminated. To further reduce power consumption, SG6741A is manufactured using the BiCMOS process, which allows an operating current of only 4mA.

SG6741A integrates a frequency-hopping function internally to reduce EMI emission of a power supply with minimum line filters. A built-in synchronized slope compensation achieves stable peak-current-mode control. The proprietary internal line compensation ensures constant output power limit over a wide AC input voltages, from 90V<sub>AC</sub> to 264V<sub>AC</sub>.

SG6741A provides many protection functions. In addition to cycle-by-cycle current limiting, the internal open-loop protection circuit ensures safety when an open-loop or output short-circuit failure occurs. PWM output is disabled until V<sub>DD</sub> drops below the UVLO lower limit, when the controller starts up again. As long as V<sub>DD</sub> exceeds ~26V, the internal OVP circuit is triggered.

SG6741A is available in an 8-pin SOP package.

## Ordering Information

Part Number	Operating Temperature Range	Package	Packing Method
SG6741ASZ	-20 to +85°C	8-Lead Small Outline Package (SOP)	Tape and Reel

 All packages are lead free per JEDEC: J-STD-020B standard.

### Application Diagram

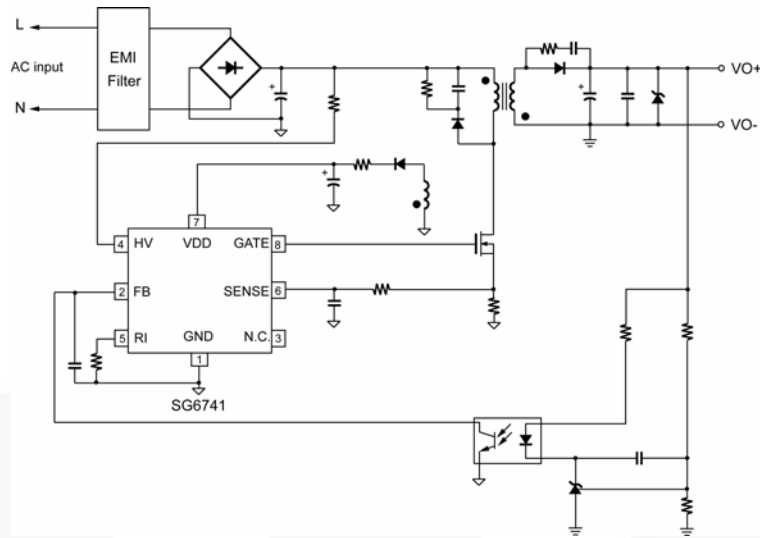

Figure 1. Typical Application

### Block Diagram

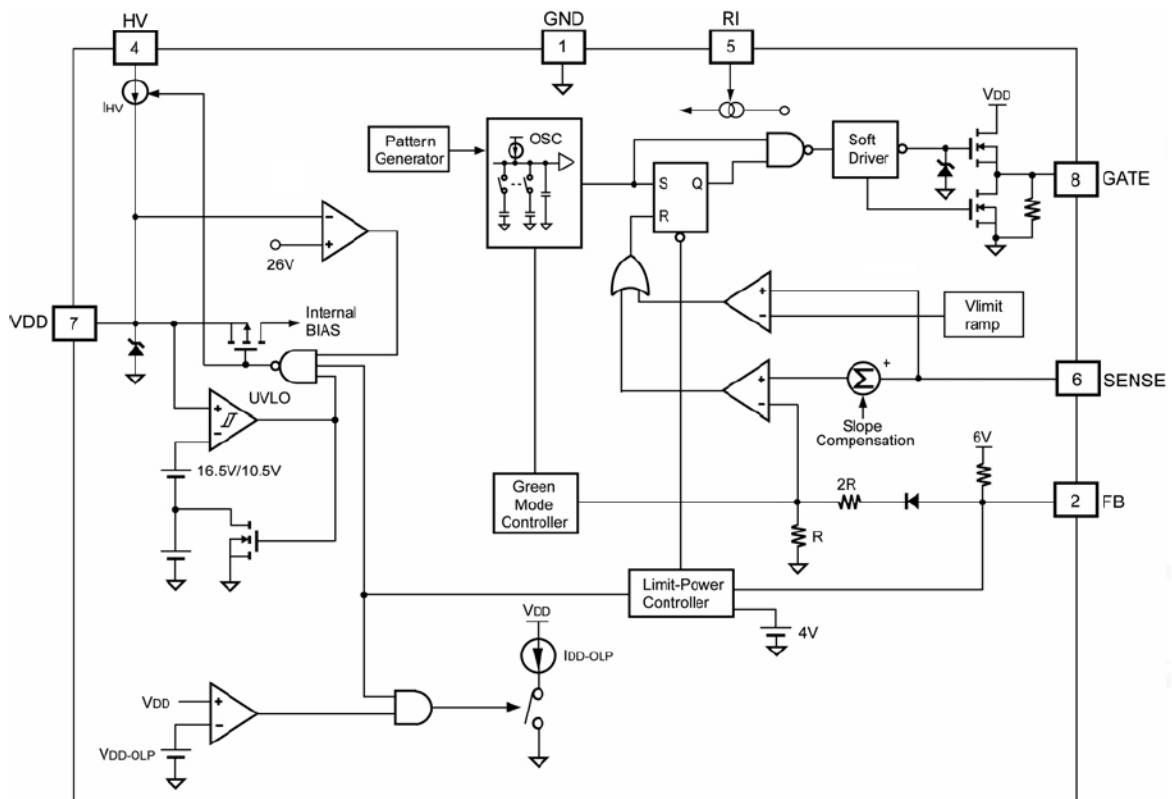

Figure 2. Block Diagram

## Marking Information

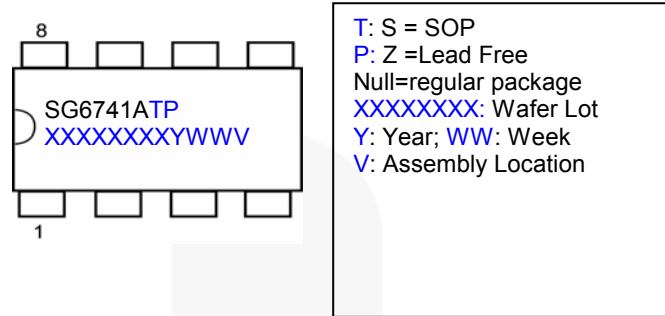

Figure 3. Top Mark

## Pin Configuration

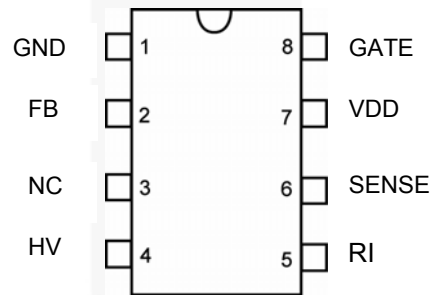

Figure 4. Pin Configuration

## Pin Definitions

Pin #	Name	Description
1	GND	<b>Ground.</b>
2	FB	<b>Feedback.</b> The signal from the external compensation circuit is fed into this pin. The PWM duty cycle is determined in response to the signal on this pin and the current-sense signal on SENSE pin.
3	NC	No Connection.
4	HV	<b>Start-up Input.</b> For start-up, this pin is pulled HIGH to the line input or bulk capacitor via resistors.
5	RI	<b>Reference Setting.</b> A resistor connected from the RI pin to GND pin provides a constant current source, which determines the center PWM frequency. Increasing the resistance reduces PWM frequency. Using a 26kΩ resistor for R <sub>I</sub> results in a 65kHz center PWM frequency.
6	SENSE	<b>Current Sense.</b> The sensed voltage is used for peak-current-mode control and cycle-by-cycle current limiting.
7	VDD	<b>Power Supply.</b> The internal protection circuit disables PWM output as long as V <sub>DD</sub> exceeds the OVP trigger point.
8	GATE	<b>Driver Output.</b> The totem-pole output driver. Soft driving waveform is implemented for improved EMI.

## Absolute Maximum Ratings

Stresses exceeding the absolute maximum ratings may damage the device. The device may not function or be operable above the recommended operating conditions and stressing the parts to these levels is not recommended. In addition, extended exposure to stresses above the recommended operating conditions may affect device reliability. The absolute maximum ratings are stress ratings only. All voltage values, except differential voltages, are given with respect to the ground pin.

Symbol	Parameter	Min.	Max.	Unit
V <sub>DD</sub>	Supply Voltage		30	
V <sub>HV</sub>	Input Voltage to HV Pin		500	
V <sub>L</sub>	Input Voltage to FB, SENSE, Pin	-3	7.0	
PD	Power Dissipation, T <sub>A</sub> < 50°C		400	mW
θ <sub>JA</sub>	Thermal Resistance (Junction-to Air)		141	°C/W
T <sub>J</sub>	Operating Junction Temperature	-40	+125	°C
T <sub>STG</sub>	Storage Temperature Range	-55	+150	°C
T <sub>L</sub>	Lead Temperature (Wave Soldering or IR, 10 Seconds)		+260	°C
ESD	Human Body Model, JESD22-A114		3	
	Machine Model, JESD22-A115		250	

## Recommended Operating Conditions

The Recommended Operating Conditions table defines the conditions for actual device operation. Recommended operating conditions are specified to ensure optimal performance to the datasheet specifications. Fairchild does not recommend exceeding them or designing to Absolute Maximum Ratings.

Symbol	Parameter	Min.	Max.	Unit
T <sub>A</sub>	Operating Ambient Temperature	-20	+85	°C

## Electrical Characteristics

$V_{DD} = 15V$ ;  $T_A = 25^\circ$ , unless otherwise noted.

### VDD Section

Symbol	Parameter	Conditions	Min.	Typ.	Max.	Units
$V_{DD-OP}$	Continuously Operating Voltage				22	V
$V_{DD-ON}$	Start Threshold Voltage		15.5	16.5	17.5	V
$V_{DD-OFF}$	Minimum Operating Voltage		9.5	10.5	11.5	V
$I_{DD-ST}$	Startup Current	$V_{DD-ON} - 0.16V$			30	$\mu A$
$I_{DD-OP}$	Operating Supply Current	$V_{DD} = 15V$ GATE Open		4	5	mA
$I_{DD-OLP}$	Internal Sink Current	$V_{DD-OLP} + 0.1V$	50	70	90	$\mu A$
$V_{DD-OLP}$	$I_{DD-OLP}$ off Voltage		6.5	7.5	8.0	V
$V_{DD-OVP}$	$V_{DD}$ Over-Voltage Protection	Auto Restart	25	26	27	V
$t_{D-VDDOVP}$	$V_{DD}$ Over-Voltage Protection Debounce Time	Auto Restart	100	180	260	$\mu s$

### HV Electrical Characteristics

Symbol	Parameter	Conditions	Typ.	Max.	Units
$I_{HV}$	Supply Current Drawn from HV Pin	$V_{AC}=90V$ ( $V_{DC}=120V$ ), $V_{DD}=10\mu F$	2		mA
$I_{HV-LC}$	Leakage Current After Startup	$HV=500V$ , $V_{DD}=V_{DD-OFF}+1V$	1	20	$\mu A$

### Oscillator Section

Symbol	Parameter	Conditions	Min.	Typ.	Max.	Units
$f_{OSC}$	Frequency in Nominal Mode	Center Frequency	62	65	68	kHz
		Hopping Range	$\pm 3.7$	$\pm 4.2$	$\pm 4.7$	
$t_{HOP}$	Hopping Period			4.4		ms
$f_{OSC-G}$	Green-Mode Frequency		16	18	21	kHz
$f_{DV}$	Frequency Variation vs. $V_{DD}$ Deviation	$V_{DD}=11V$ to $22V$			5	%
$f_{DT}$	Frequency Variation vs. Temperature Deviation	$T_A=-20$ to $85^\circ C$			5	%

### Feedback Input Section

Symbol	Parameter	Conditions	Min.	Typ.	Max.	Units
$A_V$	Input Voltage to Current-Sense Attenuation		1/3.75	1/3.20	1/2.75	V/V
$Z_{FB}$	Input Impedance		4		7	k $\Omega$
$V_{FB-OPEN}$	FB Output High Voltage	FB Pin Open	5.5			V
$V_{FB-OLP}$	FB Open-loop Trigger Level		3.7	4.0	4.3	V
$t_{D-OLP}$	The Delay Time of FB Pin Open-Loop Protection	$R_I=26k\Omega$	50	56	62	ms
$V_{FB-N}$	Green-Mode Entry FB Voltage		1.9	2.1	2.3	V
$V_{FB-G}$	Green-Mode Ending FB Voltage			$V_{FB-N} - 0.5$		V
$V_{FB-ZDC}$	Zero Duty-Cycle Input Voltage			1		V

## PWM Frequency

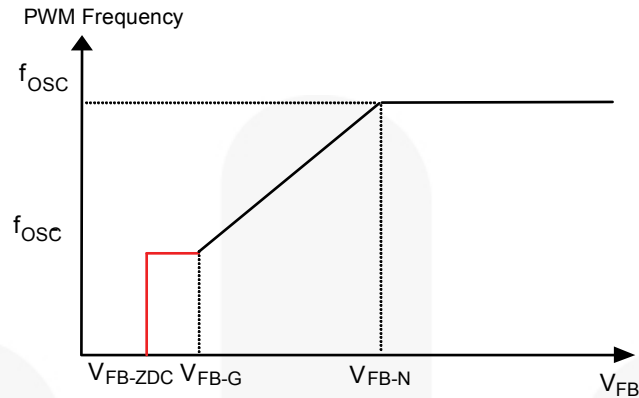

Figure 5. PWM Frequency

## Current-Sense Section

Symbol	Parameter	Conditions	Min.	Typ.	Max.	Units
$Z_{SENSE}$	Input Impedance			12		K $\Omega$
$V_{STHFL}$	Current Limit Flatten Threshold Voltage		0.87	0.90	0.93	V
$V_{STHVA}$	Current Limit Valley Threshold Voltage	$V_{STHFL} - V_{STHVA}$	0.18	0.22	0.26	V
$t_{PD}$	Delay to Output			100	200	ns
$t_{LEB}$	Leading-Edge Blanking Time		275	350	425	ns

## Gate Section

Symbol	Parameter	Conditions	Min.	Typ.	Max.	Units
$DCY_{MAX}$	Maximum Duty Cycle		60	65	70	%
$V_{GATE-L}$	Gate Low Voltage	$V_{DD}=15V, I_O=50mA$			1.5	V
$V_{GATE-H}$	Gate High Voltage	$V_{DD}=12.5V, I_O=-50mA$	8			V
$t_r$	Gate Rising Time	$V_{DD}=15V, C_L=1nF$	150	250	350	ns
$t_f$	Gate Falling Time	$V_{DD}=15V, C_L=1nF$	30	50	90	ns
$I_{GATE-SOURCE}$	Gate Source Current	$V_{DD}=15V, GATE=6V$	250			mA
$V_{GATE-CLAMP}$	Gate Output Clamping Voltage	$V_{DD}=22V$			18	V
$DCY_{MAX}$	Maximum Duty Cycle		60	65	70	%

## Typical Performance Characteristics

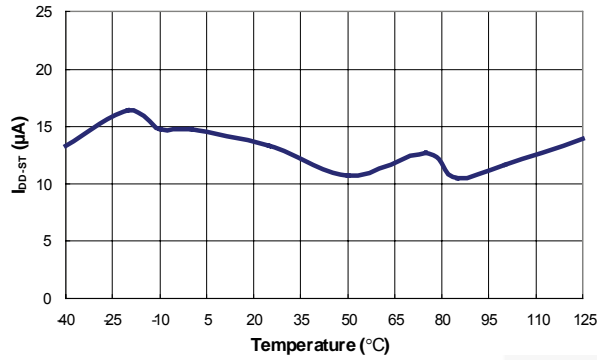

**Figure 6. Startup Current ( $I_{DD-ST}$ ) vs. Temperature**

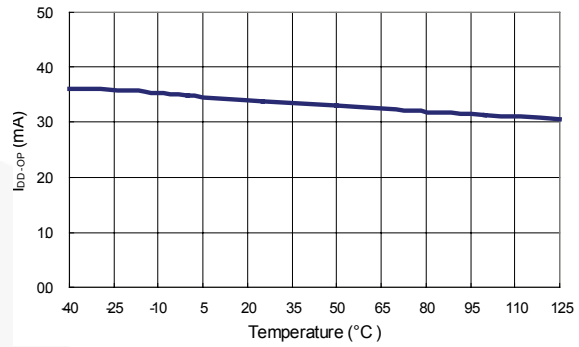

**Figure 7. Operating Supply Current ( $I_{DD-OP}$ ) vs. Temperature**

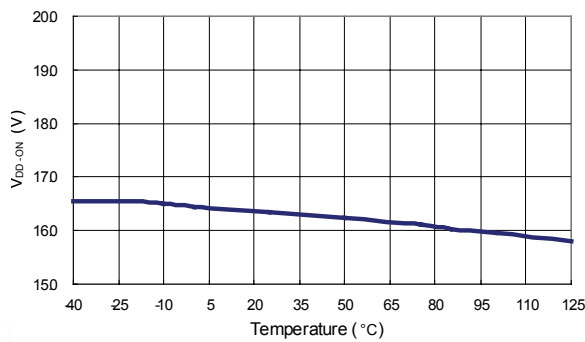

**Figure 8. Start Threshold Voltage ( $V_{DD-ON}$ ) vs. Temperature**

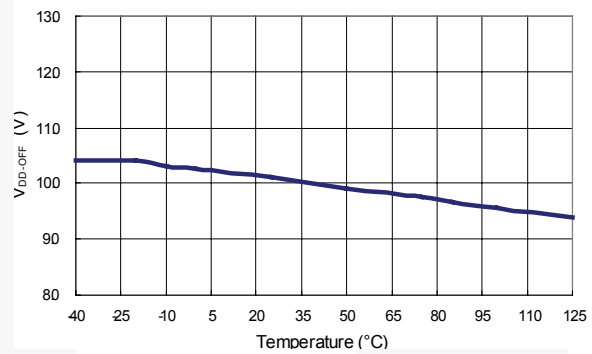

**Figure 9. Minimum Operating Voltage ( $V_{DD-OFF}$ ) vs. Temperature**

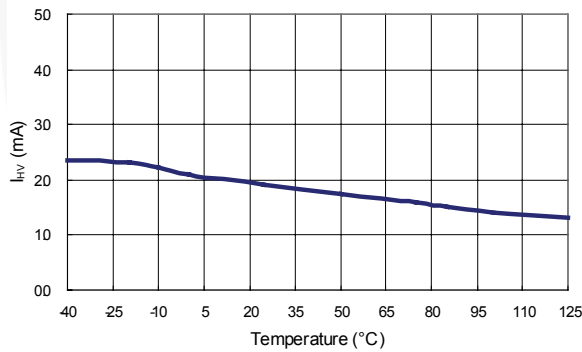

**Figure 10. Supply Current Drawn from HV Pin ( $I_{HV}$ ) vs. Temperature**

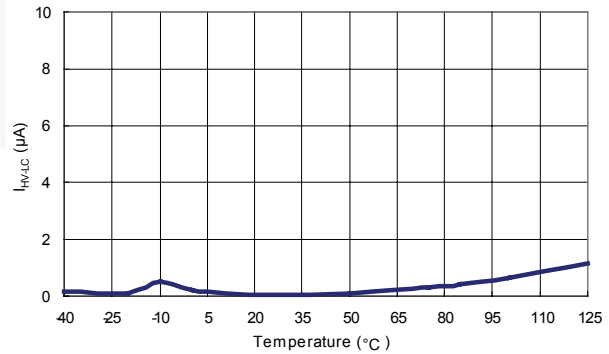

**Figure 11. Figure Caption**

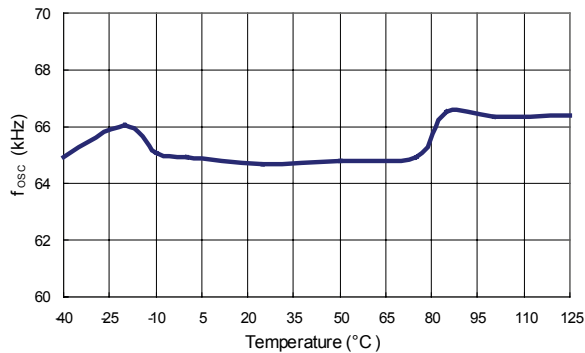

**Figure 12. Frequency in Nominal Mode ( $f_{osc}$ ) vs. Temperature**

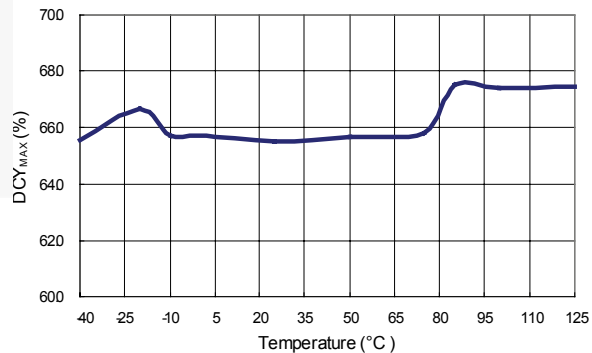

**Figure 13. Maximum Duty Cycle ( $DCY_{MAX}$ ) vs. Temperature**

## Functional Description

### Startup Current

For start-up, the HV pin is connected to the line input or bulk capacitor through an external resistor,  $R_{HV}$ , which is recommended as 100K $\Omega$ . Typical startup current drawn from pin HV is 2mA and charges the hold-up capacitor through the resistor  $R_{HV}$ . When the  $V_{DD}$  capacitor level reaches  $V_{DD-ON}$ , the startup current switches off. At this moment, the  $V_{DD}$  capacitor only supplies the SG6741A to maintain  $V_{DD}$  before the auxiliary winding of the main transformer provides the operating current.

### Operating Current

Operating current is around 4mA. The low operating current enables a better efficiency and reduces the requirement of  $V_{DD}$  hold-up capacitance.

### Green-Mode Operation

The proprietary green-mode function provides an off-time modulation to reduce the switching frequency in the light-load and no-load conditions. The on-time is limited for better abnormal or brownout protection.  $V_{FB}$ , which is derived from the voltage feedback loop, is taken as the reference. Once  $V_{FB}$  is lower than the threshold voltage, switching frequency is continuously decreased to the minimum green-mode frequency around 18KHz ( $R_I=26K\Omega$ ).

### Oscillator Operation

A resistor connected from the RI pin to the GND pin generates a constant current source for the controller. This current is used to determine the center PWM frequency. Increasing the resistance reduces PWM frequency. Using a 26K $\Omega$  resistor  $R_I$  results in a corresponding 65KHz PWM frequency. The relationship between  $R_I$  and the switching frequency is:

$$f_{PWM} = \frac{1690}{R_I (K\Omega)} (KHz) \quad (1)$$

The range of the PWM oscillation frequency is designed as 47kHz ~ 109kHz.

### Current Sensing and PWM Current Limiting

Peak-current-mode control is utilized in SG6741A to regulate output voltage and provide pulse-by-pulse current limiting. The switch current is detected by a sense resistor into the SENSE pin. The PWM duty cycle is determined by this current sense signal and  $V_{FB}$ , the feedback voltage. When the voltage on the SENSE pin reaches around  $V_{COMP} = (V_{FB}-1.2)/3.2$ , a switch cycle terminates immediately.  $V_{COMP}$  is internally clamped to a variable voltage around 0.85V for output power limit.

### Leading-Edge Blanking (LEB)

Each time the power MOSFET is switched on, a turn-on spike occurs on the sense-resistor. To avoid premature termination of the switching pulse, a leading-edge blanking time is built in. During this blanking period, the current-limit comparator is disabled and cannot switch off the gate driver.

### Under-voltage Lockout (UVLO)

The turn-on and turn-off thresholds are fixed internally at 16.5V and 10.5V. During startup, the hold-up capacitor must be charged to 16.5V through the startup resistor to enable the IC. The hold-up capacitor continues to supply  $V_{DD}$  before the energy can be delivered from auxiliary winding of the main transformer.  $V_{DD}$  must not drop below 10.5V during startup. This UVLO hysteresis window ensures that hold-up capacitor is adequate to supply  $V_{DD}$  during startup.

### Gate Output / Soft Driving

The BiCMOS output stage is a fast totem-pole gate driver. Cross conduction is avoided to minimize heat dissipation, increase efficiency, and enhance reliability. The output driver is clamped by an internal 18V Zener diode to protect power MOSFET transistors against undesirable gate over voltage. A soft driving waveform is implemented to minimize EMI.

### Built-in Slope Compensation

The sensed voltage across the current-sense resistor is used for peak-current-mode control and pulse-by-pulse current limiting. Built-in slope compensation improves stability or prevents sub-harmonic oscillation. SG6741A inserts a synchronized positive-going ramp at every switching cycle.

### Constant Output Power Limit

When the SENSE voltage, across the sense resistor  $R_s$ , reaches the threshold voltage, around 0.9V, the output GATE drive is turned off after a small delay,  $t_{PD}$ . This delay introduces an additional current proportional to  $t_{PD} \cdot V_{IN} / L_p$ . Since the delay is nearly constant, regardless of the input voltage  $V_{IN}$ , higher input voltage results in a larger additional current and the output power limit is higher than that under low input line voltage. To compensate this variation for wide AC input range, a sawtooth power-limiter is designed to solve the unequal power-limit problem. The power limiter is designed as a positive ramp signal fed to the inverting input of the OCP comparator. This results in a lower current limit at high-line inputs than at low-line inputs.



### **V<sub>DD</sub> Over-voltage Protection (OVP)**

V<sub>DD</sub> over-voltage protection has been built in to prevent damage due to abnormal conditions. Once the V<sub>DD</sub> voltage is over the V<sub>DD</sub> over-voltage protection voltage (V<sub>DD-OVP</sub>) and lasts for t<sub>D-VDDOVP</sub>, the PWM pulses are disabled until the V<sub>DD</sub> voltage drops below the UVLO, then starts again. Over-voltage conditions are usually caused by open feedback loops.

### **Limited Power Control**

The FB voltage increases every time the output of the power supply is shorted or overloaded. If the FB voltage remains higher than a built-in threshold for longer than t<sub>D-OLP</sub>, PWM output is turned off. As PWM output is turned off, the supply voltage V<sub>DD</sub> begins decreasing.

When V<sub>DD</sub> goes below the turn-off threshold (~10.5V) the controller is totally shut down. V<sub>DD</sub> is charged up to the turn-on threshold voltage of 16V through the start-up resistor until PWM output is restarted. This protection feature continues as long as the overloading condition persists. This prevents the power supply from overheating due to overloading conditions.

### **Noise Immunity**

Noise on the current sense or control signal may cause significant pulse-width jitter, particularly in continuous-conduction mode. Slope compensation helps alleviate this problem. Good placement and layout practices should be followed. Avoiding long PCB traces and component leads, locating compensation and filter components near the SG6741A, and increasing the power MOS gate resistance improve performance.

## Reference Circuit

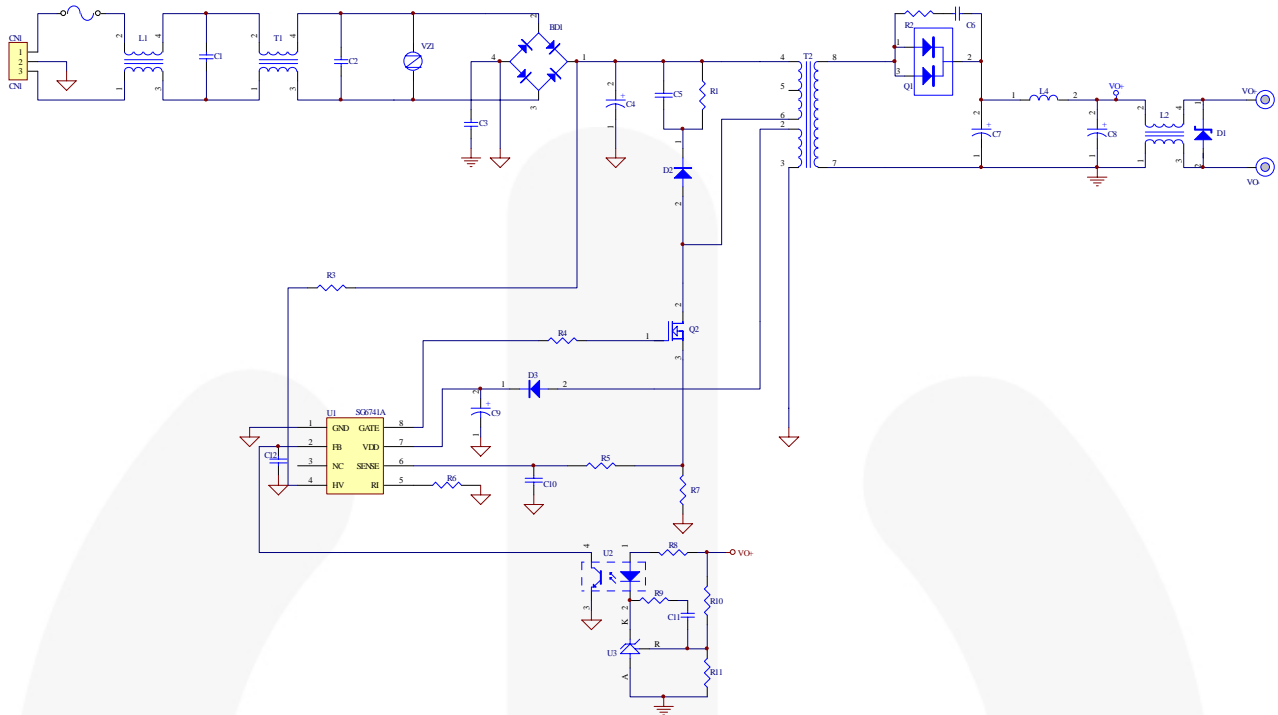

Figure 14. Circuit (12V/5A)

## BOM

Reference	Component	Reference	Component
BD1	BD 4A/600V	Q2	MOS 7A/600V
C1	XC 0.68 $\mu$ F/300V	R1	R 100K $\Omega$ 1/2W
C2	XC 0.1 $\mu$ F/300V	R2	R 47 $\Omega$ 1/4W
C3	YC 222pF/Y1	R3	R 100K $\Omega$ 1/2W
C4	EC 120 $\mu$ F/400V	R4	R 20 $\Omega$ 1/8W
C5	CC 0.01 $\mu$ F/500V	R5	R 100 $\Omega$ 1/8W
C6	CC 102pF/100V	R6	R 33K $\Omega$ 1/8W
C7	EC 1000 $\mu$ F/25V	R7	R 0.3 $\Omega$ 2W
C8	EC 470 $\mu$ F/25V	R8	R 680 $\Omega$ m 1/8W
C9	EC 22 $\mu$ F/50V	R9	R 4.7K $\Omega$ 1/8W
C10	CC 470pF/50V	R10	R 150K $\Omega$ m 1/8W
C11	CC 222pF/50V	R11	R 39K $\Omega$ 1/8W
C12	CC 103pF/50V	T1	10mH
D1	Zener Diode 15V 1/2W (option)	T2	600 $\mu$ H(PQ2620)
D2	BYV95C	U1	IC SG6741A
D3	FR103	U2	IC PC817
F1	FUSE 4A/250V	U3	IC TL431
L1	900 $\mu$ H	VZ1	VZ 9G
Q1	STP20-100CT		

## Physical Dimensions

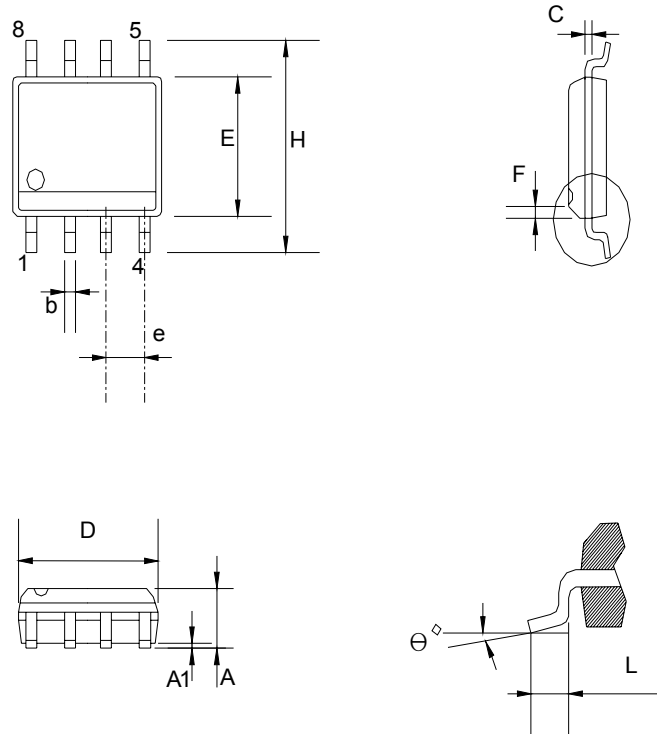

Figure 15. 8-Lead Small Outline Package (SOP)

## Dimensions

Symbol	Millimeter			Inch		
	Min.	Typ.	Max.	Min.	Typ.	Max.
A	1.346		1.752	0.053		0.069
A1	0.101		0.254	0.004		0.010
b		0.406			0.016	
c		0.203			0.008	
D	4.648		4.978	0.183		0.196
E	3.810		3.987	0.150		0.157
e	1.016	1.270	1.524	0.040	0.050	0.060
F		0.381X45°			0.015X45°	
H	5.791		6.197	0.228		0.244
L	0.406		1.270	0.016		0.050
$\theta^\circ$	0°		8°	0°		8°

Package drawings are provided as a service to customers considering Fairchild components. Drawings may change in any manner without notice. Please note the revision and/or date on the drawing and contact a Fairchild Semiconductor representative to verify or obtain the most recent revision. Package specifications do not expand the terms of Fairchild's worldwide terms and conditions, specifically the warranty therein, which covers Fairchild products.

Always visit Fairchild Semiconductor's online packaging area for the most recent package drawings:  
<http://www.fairchildsemi.com/packaging/>



**TRADEMARKS**

The following includes registered and unregistered trademarks and service marks, owned by Fairchild Semiconductor and/or its global subsidiaries, and is not intended to be an exhaustive list of all such trademarks.

- |   |   |   |   |
|---|---|---|---|
| ACEx <sup>®</sup>   | FPST <sup>™</sup>                             | PDP SPM <sup>™</sup>  | The Power Franchise <sup>®</sup>  |
| Build it Now <sup>™</sup>   | F-PFS <sup>™</sup>                            | Power-SPM <sup>™</sup>  |  |
| CorePLUS <sup>™</sup>   | FRFET <sup>®</sup>                            | PowerTrench <sup>®</sup>  | TinyBoost <sup>™</sup>  |
| CorePOWER <sup>™</sup>  | Global Power Resource <sup>SM</sup>           | Programmable Active Droop <sup>™</sup>  | TinyBuck <sup>™</sup>   |
| CROSSVOLT <sup>™</sup>  | Green FPST <sup>™</sup>                       | QFET <sup>®</sup>   | TinyLogic <sup>®</sup>  |
| CTL <sup>™</sup>  | Green FPST <sup>™</sup> e-Series <sup>™</sup> | QS <sup>™</sup>   | TINYOPTO <sup>™</sup>   |
| Current Transfer Logic <sup>™</sup>   | GTQ <sup>™</sup>                              | Quiet Series <sup>™</sup>   | TinyPower <sup>™</sup>  |
| EcoSPARK <sup>®</sup>   | IntelliMAX <sup>™</sup>                       | RapidConfigure <sup>™</sup>   | TinyPWM <sup>™</sup>  |
| EfficientMax <sup>™</sup>   | ISOPLANAR <sup>™</sup>                        | Saving our world, 1mW at a time <sup>™</sup>                                      | TinyWire <sup>™</sup>   |
| EZSWITCH <sup>™</sup> *   | MegaBuck <sup>™</sup>                         | SmartMax <sup>™</sup>   | μSerDes <sup>™</sup>  |
|  | MICROCOUPLER <sup>™</sup>                     | SMART START <sup>™</sup>  |  |
|  | MicroFET <sup>™</sup>                         | SPM <sup>®</sup>  | UHC <sup>®</sup>  |
| Fairchild <sup>®</sup>  | MicroPak <sup>™</sup>                         | STEALTH <sup>™</sup>  | Ultra FRFET <sup>™</sup>  |
| Fairchild Semiconductor <sup>®</sup>  | MillerDrive <sup>™</sup>                      | SuperFET <sup>™</sup>   | UniFET <sup>™</sup>   |
| FACT Quiet Series <sup>™</sup>  | MotionMax <sup>™</sup>                        | SuperSOT <sup>™</sup> -3  | VCX <sup>™</sup>  |
| FACT <sup>®</sup>   | Motion-SPM <sup>™</sup>                       | SuperSOT <sup>™</sup> -6  | VisualMax <sup>™</sup>  |
| FAST <sup>®</sup>   | OPTOLOGIC <sup>®</sup>                        | SuperSOT <sup>™</sup> -8  |   |
| FastvCore <sup>™</sup>  | OPTOPLANAR <sup>®</sup>                       | SupreMOS <sup>™</sup>   |   |
| FlashWriter <sup>®</sup> *  |   | SyncFET <sup>™</sup>  |   |
|   |   |  |   |

\* EZSWITCH<sup>™</sup> and FlashWriter<sup>®</sup> are trademarks of System General Corporation, used under license by Fairchild Semiconductor.

**DISCLAIMER**

FAIRCHILD SEMICONDUCTOR RESERVES THE RIGHT TO MAKE CHANGES WITHOUT FURTHER NOTICE TO ANY PRODUCTS HEREIN TO IMPROVE RELIABILITY, FUNCTION, OR DESIGN. FAIRCHILD DOES NOT ASSUME ANY LIABILITY ARISING OUT OF THE APPLICATION OR USE OF ANY PRODUCT OR CIRCUIT DESCRIBED HEREIN; NEITHER DOES IT CONVEY ANY LICENSE UNDER ITS PATENT RIGHTS, NOR THE RIGHTS OF OTHERS. THESE SPECIFICATIONS DO NOT EXPAND THE TERMS OF FAIRCHILD'S WORLDWIDE TERMS AND CONDITIONS, SPECIFICALLY THE WARRANTY THEREIN, WHICH COVERS THESE PRODUCTS.

**LIFE SUPPORT POLICY**

FAIRCHILD'S PRODUCTS ARE NOT AUTHORIZED FOR USE AS CRITICAL COMPONENTS IN LIFE SUPPORT DEVICES OR SYSTEMS WITHOUT THE EXPRESS WRITTEN APPROVAL OF FAIRCHILD SEMICONDUCTOR CORPORATION.

As used herein:

1. Life support devices or systems are devices or systems which, (a) are intended for surgical implant into the body or (b) support or sustain life, and (c) whose failure to perform when properly used in accordance with instructions for use provided in the labeling, can be reasonably expected to result in a significant injury of the user.
2. A critical component in any component of a life support, device, or system whose failure to perform can be reasonably expected to cause the failure of the life support device or system, or to affect its safety or effectiveness.

**PRODUCT STATUS DEFINITIONS**

**Definition of Terms**

Datasheet Identification	Product Status	Definition
Advance Information	Formative / In Design	This datasheet contains the design specifications for product development. Specifications may change in any manner without notice.
Preliminary	First Production	This datasheet contains preliminary data; supplementary data will be published at a later date. Fairchild Semiconductor reserves the right to make changes at any time without notice to improve design.
No Identification Needed	Full Production	This datasheet contains final specifications. Fairchild Semiconductor reserves the right to make changes at any time without notice to improve the design.
Obsolete	Not In Production	This datasheet contains specifications on a product that is discontinued by Fairchild Semiconductor. The datasheet is for reference information only.

Rev. 134