

The revision list can be viewed directly by clicking the title page.

The revision list summarizes the locations of revisions and additions. Details should always be checked by referring to the relevant text.

32

H8SX/1638 Group, H8SX/1638L Group

Hardware Manual

Renesas 32-Bit CISC Microcomputer H8SX Family / H8SX/1600 Series

H8SX/1638	R5F61638
H8SX/1634	R5F61634
H8SX/1632	R5F61632
H8SX/1638L	R5F61638L
H8SX/1634L	R5F61634L
H8SX/1632L	R5F61632L

All information contained in this material, including products and product specifications at the time of publication of this material, is subject to change by Renesas Technology Corp. without notice. Please review the latest information published by Renesas Technology Corp. through various means, including the Renesas Technology Corp. website (<http://www.renesas.com>).

Rev.2.00

Revision Date: Sep. 10, 2008

Renesas Technology
www.renesas.com

Notes regarding these materials

1. This document is provided for reference purposes only so that Renesas customers may select the appropriate Renesas products for their use. Renesas neither makes warranties or representations with respect to the accuracy or completeness of the information contained in this document nor grants any license to any intellectual property rights or any other rights of Renesas or any third party with respect to the information in this document.
2. Renesas shall have no liability for damages or infringement of any intellectual property or other rights arising out of the use of any information in this document, including, but not limited to, product data, diagrams, charts, programs, algorithms, and application circuit examples.
3. You should not use the products or the technology described in this document for the purpose of military applications such as the development of weapons of mass destruction or for the purpose of any other military use. When exporting the products or technology described herein, you should follow the applicable export control laws and regulations, and procedures required by such laws and regulations.
4. All information included in this document such as product data, diagrams, charts, programs, algorithms, and application circuit examples, is current as of the date this document is issued. Such information, however, is subject to change without any prior notice. Before purchasing or using any Renesas products listed in this document, please confirm the latest product information with a Renesas sales office. Also, please pay regular and careful attention to additional and different information to be disclosed by Renesas such as that disclosed through our website. (<http://www.renesas.com>)
5. Renesas has used reasonable care in compiling the information included in this document, but Renesas assumes no liability whatsoever for any damages incurred as a result of errors or omissions in the information included in this document.
6. When using or otherwise relying on the information in this document, you should evaluate the information in light of the total system before deciding about the applicability of such information to the intended application. Renesas makes no representations, warranties or guaranties regarding the suitability of its products for any particular application and specifically disclaims any liability arising out of the application and use of the information in this document or Renesas products.
7. With the exception of products specified by Renesas as suitable for automobile applications, Renesas products are not designed, manufactured or tested for applications or otherwise in systems the failure or malfunction of which may cause a direct threat to human life or create a risk of human injury or which require especially high quality and reliability such as safety systems, or equipment or systems for transportation and traffic, healthcare, combustion control, aerospace and aeronautics, nuclear power, or undersea communication transmission. If you are considering the use of our products for such purposes, please contact a Renesas sales office beforehand. Renesas shall have no liability for damages arising out of the uses set forth above.
8. Notwithstanding the preceding paragraph, you should not use Renesas products for the purposes listed below:
 - (1) artificial life support devices or systems
 - (2) surgical implantations
 - (3) healthcare intervention (e.g., excision, administration of medication, etc.)
 - (4) any other purposes that pose a direct threat to human lifeRenesas shall have no liability for damages arising out of the uses set forth in the above and purchasers who elect to use Renesas products in any of the foregoing applications shall indemnify and hold harmless Renesas Technology Corp., its affiliated companies and their officers, directors, and employees against any and all damages arising out of such applications.
9. You should use the products described herein within the range specified by Renesas, especially with respect to the maximum rating, operating supply voltage range, movement power voltage range, heat radiation characteristics, installation and other product characteristics. Renesas shall have no liability for malfunctions or damages arising out of the use of Renesas products beyond such specified ranges.
10. Although Renesas endeavors to improve the quality and reliability of its products, IC products have specific characteristics such as the occurrence of failure at a certain rate and malfunctions under certain use conditions. Please be sure to implement safety measures to guard against the possibility of physical injury, and injury or damage caused by fire in the event of the failure of a Renesas product, such as safety design for hardware and software including but not limited to redundancy, fire control and malfunction prevention, appropriate treatment for aging degradation or any other applicable measures. Among others, since the evaluation of microcomputer software alone is very difficult, please evaluate the safety of the final products or system manufactured by you.
11. In case Renesas products listed in this document are detached from the products to which the Renesas products are attached or affixed, the risk of accident such as swallowing by infants and small children is very high. You should implement safety measures so that Renesas products may not be easily detached from your products. Renesas shall have no liability for damages arising out of such detachment.
12. This document may not be reproduced or duplicated, in any form, in whole or in part, without prior written approval from Renesas.
13. Please contact a Renesas sales office if you have any questions regarding the information contained in this document, Renesas semiconductor products, or if you have any other inquiries.

General Precautions in the Handling of MPU/MCU Products

The following usage notes are applicable to all MPU/MCU products from Renesas. For detailed usage notes on the products covered by this manual, refer to the relevant sections of the manual. If the descriptions under General Precautions in the Handling of MPU/MCU Products and in the body of the manual differ from each other, the description in the body of the manual takes precedence.

1. Handling of Unused Pins

Handle unused pins in accord with the directions given under Handling of Unused Pins in the manual.

- The input pins of CMOS products are generally in the high-impedance state. In operation with an unused pin in the open-circuit state, extra electromagnetic noise is induced in the vicinity of LSI, an associated shoot-through current flows internally, and malfunctions occur due to the false recognition of the pin state as an input signal become possible. Unused pins should be handled as described under Handling of Unused Pins in the manual.

2. Processing at Power-on

The state of the product is undefined at the moment when power is supplied.

- The states of internal circuits in the LSI are indeterminate and the states of register settings and pins are undefined at the moment when power is supplied.

In a finished product where the reset signal is applied to the external reset pin, the states of pins are not guaranteed from the moment when power is supplied until the reset process is completed.

In a similar way, the states of pins in a product that is reset by an on-chip power-on reset function are not guaranteed from the moment when power is supplied until the power reaches the level at which resetting has been specified.

3. Prohibition of Access to Reserved Addresses

Access to reserved addresses is prohibited.

- The reserved addresses are provided for the possible future expansion of functions. Do not access these addresses; the correct operation of LSI is not guaranteed if they are accessed.

4. Clock Signals

After applying a reset, only release the reset line after the operating clock signal has become stable. When switching the clock signal during program execution, wait until the target clock signal has stabilized.

- When the clock signal is generated with an external resonator (or from an external oscillator) during a reset, ensure that the reset line is only released after full stabilization of the clock signal. Moreover, when switching to a clock signal produced with an external resonator (or by an external oscillator) while program execution is in progress, wait until the target clock signal is stable.

5. Differences between Products

Before changing from one product to another, i.e. to one with a different part number, confirm that the change will not lead to problems.

- The characteristics of MPU/MCU in the same group but having different part numbers may differ because of the differences in internal memory capacity and layout pattern. When changing to products of different part numbers, implement a system-evaluation test for each of the products.

How to Use This Manual

1. Objective and Target Users

This manual was written to explain the hardware functions and electrical characteristics of this LSI to the target users, i.e. those who will be using this LSI in the design of application systems. Target users are expected to understand the fundamentals of electrical circuits, logic circuits, and microcomputers.

This manual is organized in the following items: an overview of the product, descriptions of the CPU, system control functions, and peripheral functions, electrical characteristics of the device, and usage notes.

When designing an application system that includes this LSI, take all points to note into account. Points to note are given in their contexts and at the final part of each section, and in the section giving usage notes.

The list of revisions is a summary of major points of revision or addition for earlier versions. It does not cover all revised items. For details on the revised points, see the actual locations in the manual.

The following documents have been prepared for the H8SX/1638, H8SX/1638L Group. Before using any of the documents, please visit our web site to verify that you have the most up-to-date available version of the document.

Document Type	Contents	Document Title	Document No.
Data Sheet	Overview of hardware and electrical characteristics	—	—
Hardware Manual	Hardware specifications (pin assignments, memory maps, peripheral specifications, electrical characteristics, and timing charts) and descriptions of operation	H8SX/1638, H8SX/1638L Group Hardware Manual	This manual
Software Manual	Detailed descriptions of the CPU and instruction set	H8SX Family Software Manual	REJ09B0102
Application Note	Examples of applications and sample programs	The latest versions are available from our web site.	
Renesas Technical Update	Preliminary report on the specifications of a product, document, etc.		

2. Description of Numbers and Symbols

Aspects of the notations for register names, bit names, numbers, and symbolic names in this manual are explained below.

(1) Overall notation

In descriptions involving the names of bits and bit fields within this manual, the modules and registers to which the bits belong may be clarified by giving the names in the forms "module name"."register name"."bit name" or "register name"."bit name".

(2) Register notation

The style "register name"_"instance number" is used in cases where there is more than one instance of the same function or similar functions.

[Example] CMCSR_0: Indicates the CMCSR register for the compare-match timer of channel 0.

(3) Number notation

Binary numbers are given as B'nnnn (B' may be omitted if the number is obviously binary), hexadecimal numbers are given as H'nnnn or 0xnnnn, and decimal numbers are given as nnnn.

[Examples] Binary: B'11 or 11
Hexadecimal: H'EFA0 or 0xEFA0
Decimal: 1234

(4) Notation for active-low

An overbar on the name indicates that a signal or pin is active-low.

[Example] $\overline{\text{WDTOVF}}$

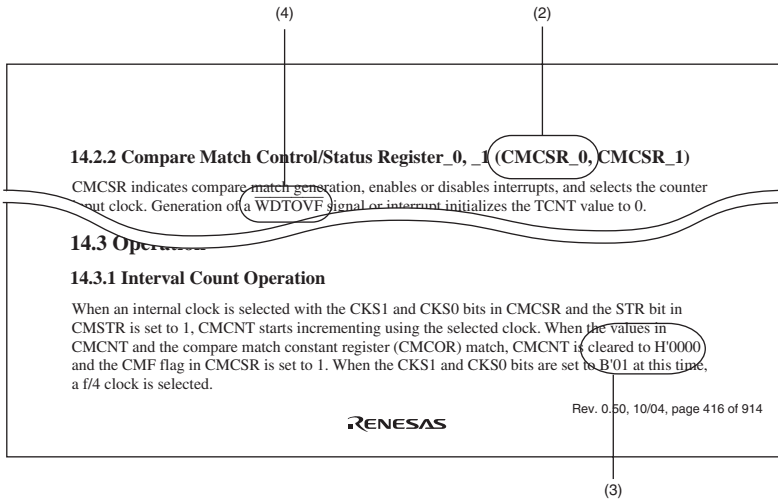

Note: The bit names and sentences in the above figure are examples and have nothing to do with the contents of this manual.

3. Description of Registers

Each register description includes a bit chart, illustrating the arrangement of bits, and a table of bits, describing the meanings of the bit settings. The standard format and notation for bit charts and tables are described below.

[Bit Chart]

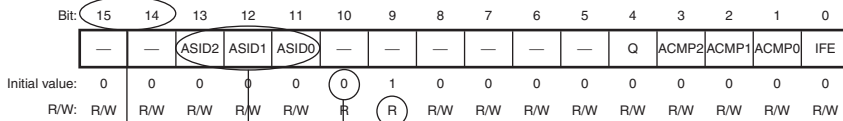

[Table of Bits]

Bit	Bit Name	Initial Value	R/W	Description
15	—	0	R	Reserved
14	—	0	R	Reserved
13 to 11	ASID2 to ASID0	All 0	R/W	Address Identifier These bits enable or disable the pin function.
10	—	0	R	Reserved This bit is always read as 0.
9	—	1	R	Reserved This bit is always read as 1.
8 to 0	—	0		

Note: The bit names and sentences in the above figure are examples, and have nothing to do with the contents of this manual.

- (1) Bit
Indicates the bit number or numbers.
In the case of a 32-bit register, the bits are arranged in order from 31 to 0. In the case of a 16-bit register, the bits are arranged in order from 15 to 0.
- (2) Bit name
Indicates the name of the bit or bit field.
When the number of bits has to be clearly indicated in the field, appropriate notation is included (e.g., ASID[3:0]).
A reserved bit is indicated by "—".
Certain kinds of bits, such as those of timer counters, are not assigned bit names. In such cases, the entry under Bit Name is blank.
- (3) Initial value
Indicates the value of each bit immediately after a power-on reset, i.e., the initial value.
0: The initial value is 0
1: The initial value is 1
—: The initial value is undefined
- (4) R/W
For each bit and bit field, this entry indicates whether the bit or field is readable or writable, or both writing to and reading from the bit or field are impossible.
The notation is as follows:
R/W: The bit or field is readable and writable.
R/(W): The bit or field is readable and writable.
However, writing is only performed to flag clearing.
R: The bit or field is readable.
"R" is indicated for all reserved bits. When writing to the register, write the value under Initial Value in the bit chart to reserved bits or fields.
W: The bit or field is writable.
- (5) Description
Describes the function of the bit or field and specifies the values for writing.

4. Description of Abbreviations

The abbreviations used in this manual are listed below.

- Abbreviations specific to this product

Abbreviation	Description
BSC	Bus controller
CPG	Clock pulse generator
DTC	Data transfer controller
INTC	Interrupt controller
PPG	Programmable pulse generator
SCI	Serial communication interface
TMR	8-bit timer
TPU	16-bit timer pulse unit
WDT	Watchdog timer

- Abbreviations other than those listed above

Abbreviation	Description
ACIA	Asynchronous communication interface adapter
bps	Bits per second
CRC	Cyclic redundancy check
DMA	Direct memory access
DMAC	Direct memory access controller
GSM	Global System for Mobile Communications
Hi-Z	High impedance
IEBus	Inter Equipment Bus (IEBus is a trademark of NEC Electronics Corporation.)
I/O	Input/output
IrDA	Infrared Data Association
LSB	Least significant bit
MSB	Most significant bit
NC	No connection
PLL	Phase-locked loop
PWM	Pulse width modulation
SFR	Special function register
SIM	Subscriber Identity Module
UART	Universal asynchronous receiver/transmitter
VCO	Voltage-controlled oscillator

All trademarks and registered trademarks are the property of their respective owners.

Contents

Section 1	Overview	1
1.1	Features	1
1.1.1	Applications	1
1.1.2	Overview of Functions	2
1.2	List of Products	9
1.3	Block Diagram	11
1.4	Pin Assignments	12
1.4.1	Pin Assignments	12
1.4.2	Correspondence between Pin Configuration and Operating Modes	13
1.4.3	Pin Functions	18
Section 2	CPU	25
2.1	Features	25
2.2	CPU Operating Modes	27
2.2.1	Normal Mode	27
2.2.2	Middle Mode	29
2.2.3	Advanced Mode	30
2.2.4	Maximum Mode	31
2.3	Instruction Fetch	33
2.4	Address Space	33
2.5	Registers	34
2.5.1	General Registers	35
2.5.2	Program Counter (PC)	36
2.5.3	Condition-Code Register (CCR)	37
2.5.4	Extended Control Register (EXR)	38
2.5.5	Vector Base Register (VBR)	39
2.5.6	Short Address Base Register (SBR)	39
2.5.7	Multiply-Accumulate Register (MAC)	39
2.5.8	Initial Values of CPU Registers	39
2.6	Data Formats	40
2.6.1	General Register Data Formats	40
2.6.2	Memory Data Formats	41
2.7	Instruction Set	42
2.7.1	Instructions and Addressing Modes	44
2.7.2	Table of Instructions Classified by Function	48
2.7.3	Basic Instruction Formats	58

2.8	Addressing Modes and Effective Address Calculation.....	59
2.8.1	Register Direct—Rn	59
2.8.2	Register Indirect—@ERn.....	60
2.8.3	Register Indirect with Displacement —@(d:2, ERn), @(d:16, ERn), or @(d:32, ERn).....	60
2.8.4	Index Register Indirect with Displacement—@(d:16,RnL.B), @(d:32,RnL.B), @(d:16,Rn.W), @(d:32,Rn.W), @(d:16,ERn.L), or @(d:32,ERn.L).....	60
2.8.5	Register Indirect with Post-Increment, Pre-Decrement, Pre-Increment, or Post-Decrement—@ERn+, @-ERn, @+ERn, or @ERn-	61
2.8.6	Absolute Address—@aa:8, @aa:16, @aa:24, or @aa:32.....	62
2.8.7	Immediate—#xx	63
2.8.8	Program-Counter Relative—@(d:8, PC) or @(d:16, PC)	63
2.8.9	Program-Counter Relative with Index Register—@(RnL.B, PC), @(Rn.W, PC), or @(ERn.L, PC).....	63
2.8.10	Memory Indirect—@@aa:8	64
2.8.11	Extended Memory Indirect—@@vec:7	65
2.8.12	Effective Address Calculation	65
2.8.13	MOVA Instruction.....	67
2.9	Processing States	68
Section 3 MCU Operating Modes		69
3.1	Operating Mode Selection	69
3.2	Register Descriptions.....	70
3.2.1	Mode Control Register (MDCR)	70
3.2.2	System Control Register (SYSCR).....	72
3.3	Operating Mode Descriptions	74
3.3.1	Mode 1	74
3.3.2	Mode 2.....	74
3.3.3	Mode 3.....	74
3.3.4	Mode 4.....	74
3.3.5	Mode 5.....	75
3.3.6	Mode 6.....	75
3.3.7	Mode 7.....	75
3.3.8	Pin Functions	76
3.4	Address Map.....	76
3.4.1	Address Map.....	76
Section 4 Resets.....		83
4.1	Types of Resets.....	83
4.2	Input/Output Pin	85

4.3	Register Descriptions	86
4.3.1	Reset Status Register (RSTSR).....	86
4.3.2	Reset Control/Status Register (RSTCSR).....	88
4.4	Pin Reset	89
4.5	Power-on Reset (POR) (H8SX/1638L Group)	89
4.6	Power Supply Monitoring Reset (H8SX1638L Group).....	90
4.7	Deep Software Standby Reset.....	91
4.8	Watchdog Timer Reset	91
4.9	Determination of Reset Generation Source.....	92
Section 5 Voltage Detection Circuit (LVD)		93
5.1	Features	93
5.2	Register Descriptions	94
5.2.1	Voltage Detection Control Register (LVDCR).....	94
5.2.2	Reset Status Register (RSTSR).....	95
5.3	Voltage Detection Circuit	97
5.3.1	Voltage Monitoring Reset.....	97
5.3.2	Voltage Monitoring Interrupt.....	98
5.3.3	Release from Deep Software Standby Mode by the Voltage-Detection Circuit	100
5.3.4	Voltage Monitor.....	100
Section 6 Exception Handling		101
6.1	Exception Handling Types and Priority.....	101
6.2	Exception Sources and Exception Handling Vector Table	102
6.3	Reset	104
6.3.1	Reset Exception Handling.....	104
6.3.2	Interrupts after Reset.....	105
6.3.3	On-Chip Peripheral Functions after Reset Release	105
6.4	Traces.....	107
6.5	Address Error.....	108
6.5.1	Address Error Source.....	108
6.5.2	Address Error Exception Handling	109
6.6	Interrupts.....	110
6.6.1	Interrupt Sources.....	110
6.6.2	Interrupt Exception Handling	111
6.7	Instruction Exception Handling	111
6.7.1	Trap Instruction.....	111
6.7.2	Sleep Instruction Exception Handling	112
6.7.3	Exception Handling by Illegal Instruction	113

6.8	Stack Status after Exception Handling	114
6.9	Usage Note	115
Section 7 Interrupt Controller.....		117
7.1	Features.....	117
7.2	Input/Output Pins.....	119
7.3	Register Descriptions.....	119
7.3.1	Interrupt Control Register (INTCR)	120
7.3.2	CPU Priority Control Register (CPUPCR).....	121
7.3.3	Interrupt Priority Registers A to I, K to O, Q, and R (IPRA to IPRI, IPRK to IPRO, IPRQ, and IPRR)	122
7.3.4	IRQ Enable Register (IER)	124
7.3.5	IRQ Sense Control Registers H and L (ISCRH, ISCLR).....	126
7.3.6	IRQ Status Register (ISR).....	131
7.3.7	Software Standby Release IRQ Enable Register (SSIER)	134
7.4	Interrupt Sources.....	135
7.4.1	External Interrupts	135
7.4.2	Internal Interrupts	136
7.5	Interrupt Exception Handling Vector Table.....	137
7.6	Interrupt Control Modes and Interrupt Operation.....	143
7.6.1	Interrupt Control Mode 0.....	143
7.6.2	Interrupt Control Mode 2.....	145
7.6.3	Interrupt Exception Handling Sequence	147
7.6.4	Interrupt Response Times	148
7.6.5	DTC and DMAC Activation by Interrupt.....	149
7.7	CPU Priority Control Function Over DTC and DMAC.....	152
7.8	Usage Notes.....	155
7.8.1	Conflict between Interrupt Generation and Disabling	155
7.8.2	Instructions that Disable Interrupts.....	156
7.8.3	Times when Interrupts are Disabled	156
7.8.4	Interrupts during Execution of EEPMOV Instruction	156
7.8.5	Interrupts during Execution of MOVMD and MOVSD Instructions.....	156
7.8.6	Interrupts of Peripheral Modules	157
Section 8 User Break Controller (UBC).....		159
8.1	Features.....	159
8.2	Block Diagram.....	160
8.3	Register Descriptions.....	161
8.3.1	Break Address Register n (BARA, BARB, BARC, BARD)	162
8.3.2	Break Address Mask Register n (BAMRA, BAMRB, BAMRC, BAMRD)	163

8.3.3	Break Control Register n (BRCRA, BRCRB, BRCRC, BRCRD)	164
8.4	Operation	166
8.4.1	Setting of Break Control Conditions.....	166
8.4.2	PC Break.....	166
8.4.3	Condition Match Flag	167
8.5	Usage Notes	168
Section 9 Bus Controller (BSC).....		171
9.1	Features.....	171
9.2	Register Descriptions	174
9.2.1	Bus Width Control Register (ABWCR).....	175
9.2.2	Access State Control Register (ASTCR)	176
9.2.3	Wait Control Registers A and B (WTCRA, WTCRB)	177
9.2.4	Read Strobe Timing Control Register (RDNCR)	182
9.2.5	\overline{CS} Assertion Period Control Registers (CSACR)	183
9.2.6	Idle Control Register (IDLCR)	186
9.2.7	Bus Control Register 1 (BCR1)	188
9.2.8	Bus Control Register 2 (BCR2)	190
9.2.9	Endian Control Register (ENDIANCR).....	191
9.2.10	SRAM Mode Control Register (SRAMCR)	192
9.2.11	Burst ROM Interface Control Register (BROMCR).....	193
9.2.12	Address/Data Multiplexed I/O Control Register (MPXCR)	195
9.3	Bus Configuration.....	196
9.4	Multi-Clock Function and Number of Access Cycles	197
9.5	External Bus.....	201
9.5.1	Input/Output Pins	201
9.5.2	Area Division.....	204
9.5.3	Chip Select Signals	205
9.5.4	External Bus Interface.....	206
9.5.5	Area and External Bus Interface	210
9.5.6	Endian and Data Alignment.....	215
9.6	Basic Bus Interface	218
9.6.1	Data Bus.....	218
9.6.2	I/O Pins Used for Basic Bus Interface	218
9.6.3	Basic Timing.....	219
9.6.4	Wait Control	225
9.6.5	Read Strobe (\overline{RD}) Timing.....	227
9.6.6	Extension of Chip Select (\overline{CS}) Assertion Period.....	228
9.6.7	\overline{DACK} Signal Output Timing	230
9.7	Byte Control SRAM Interface	231

9.7.1	Byte Control SRAM Space Setting.....	231
9.7.2	Data Bus	231
9.7.3	I/O Pins Used for Byte Control SRAM Interface	232
9.7.4	Basic Timing.....	233
9.7.5	Wait Control	235
9.7.6	Read Strobe (\overline{RD})	237
9.7.7	Extension of Chip Select (\overline{CS}) Assertion Period.....	237
9.7.8	\overline{DACK} Signal Output Timing	237
9.8	Burst ROM Interface	239
9.8.1	Burst ROM Space Setting.....	239
9.8.2	Data Bus	239
9.8.3	I/O Pins Used for Burst ROM Interface.....	240
9.8.4	Basic Timing.....	241
9.8.5	Wait Control	243
9.8.6	Read Strobe (\overline{RD}) Timing	243
9.8.7	Extension of Chip Select (\overline{CS}) Assertion Period.....	243
9.9	Address/Data Multiplexed I/O Interface.....	244
9.9.1	Address/Data Multiplexed I/O Space Setting	244
9.9.2	Address/Data Multiplex	244
9.9.3	Data Bus	244
9.9.4	I/O Pins Used for Address/Data Multiplexed I/O Interface	245
9.9.5	Basic Timing.....	246
9.9.6	Address Cycle Control.....	248
9.9.7	Wait Control	249
9.9.8	Read Strobe (\overline{RD}) Timing	249
9.9.9	Extension of Chip Select (\overline{CS}) Assertion Period.....	251
9.9.10	\overline{DACK} Signal Output Timing	253
9.10	Idle Cycle.....	254
9.10.1	Operation	254
9.10.2	Pin States in Idle Cycle.....	263
9.11	Bus Release.....	264
9.11.1	Operation	264
9.11.2	Pin States in External Bus Released State	265
9.11.3	Transition Timing	266
9.12	Internal Bus.....	267
9.12.1	Access to Internal Address Space	267
9.13	Write Data Buffer Function	268
9.13.1	Write Data Buffer Function for External Data Bus	268
9.13.2	Write Data Buffer Function for Peripheral Modules	269
9.14	Bus Arbitration	270

9.14.1	Operation	270
9.14.2	Bus Transfer Timing	271
9.15	Bus Controller Operation in Reset	273
9.16	Usage Notes	273
Section 10 DMA Controller (DMAC)		275
10.1	Features	275
10.2	Input/Output Pins	278
10.3	Register Descriptions	279
10.3.1	DMA Source Address Register (DSAR).....	280
10.3.2	DMA Destination Address Register (DDAR).....	281
10.3.3	DMA Offset Register (DOFR).....	282
10.3.4	DMA Transfer Count Register (DTCR)	283
10.3.5	DMA Block Size Register (DBSR)	284
10.3.6	DMA Mode Control Register (DMDR).....	285
10.3.7	DMA Address Control Register (DACR).....	294
10.3.8	DMA Module Request Select Register (DMRSR)	300
10.4	Transfer Modes	300
10.5	Operations.....	301
10.5.1	Address Modes	301
10.5.2	Transfer Modes	305
10.5.3	Activation Sources	310
10.5.4	Bus Access Modes	312
10.5.5	Extended Repeat Area Function	314
10.5.6	Address Update Function using Offset	317
10.5.7	Register during DMA Transfer	321
10.5.8	Priority of Channels	326
10.5.9	DMA Basic Bus Cycle.....	328
10.5.10	Bus Cycles in Dual Address Mode	329
10.5.11	Bus Cycles in Single Address Mode.....	338
10.6	DMA Transfer End	343
10.7	Relationship among DMAC and Other Bus Masters	346
10.7.1	CPU Priority Control Function Over DMAC	346
10.7.2	Bus Arbitration among DMAC and Other Bus Masters	347
10.8	Interrupt Sources.....	348
10.9	Usage Notes	351
Section 11 Data Transfer Controller (DTC)		353
11.1	Features.....	353
11.2	Register Descriptions	355

11.2.1	DTC Mode Register A (MRA)	356
11.2.2	DTC Mode Register B (MRB).....	357
11.2.3	DTC Source Address Register (SAR).....	358
11.2.4	DTC Destination Address Register (DAR).....	359
11.2.5	DTC Transfer Count Register A (CRA)	359
11.2.6	DTC Transfer Count Register B (CRB).....	360
11.2.7	DTC enable registers A to H (DTCERA to DTCERF).....	360
11.2.8	DTC Control Register (DTCCR)	361
11.2.9	DTC Vector Base Register (DTCVBR).....	363
11.3	Activation Sources	363
11.4	Location of Transfer Information and DTC Vector Table.....	363
11.5	Operation	368
11.5.1	Bus Cycle Division	370
11.5.2	Transfer Information Read Skip Function	372
11.5.3	Transfer Information Writeback Skip Function.....	373
11.5.4	Normal Transfer Mode	373
11.5.5	Repeat Transfer Mode	374
11.5.6	Block Transfer Mode.....	376
11.5.7	Chain Transfer	377
11.5.8	Operation Timing.....	378
11.5.9	Number of DTC Execution Cycles	380
11.5.10	DTC Bus Release Timing	381
11.5.11	DTC Priority Level Control to the CPU	381
11.6	DTC Activation by Interrupt.....	382
11.7	Examples of Use of the DTC.....	383
11.7.1	Normal Transfer Mode	383
11.7.2	Chain Transfer	383
11.7.3	Chain Transfer when Counter = 0.....	384
11.8	Interrupt Sources.....	386
11.9	Usage Notes	386
11.9.1	Module Stop State Setting	386
11.9.2	On-Chip RAM	386
11.9.3	DMAC Transfer End Interrupt.....	386
11.9.4	DTCE Bit Setting.....	386
11.9.5	Chain Transfer	387
11.9.6	Transfer Information Start Address, Source Address, and Destination Address	387
11.9.7	Transfer Information Modification	387
11.9.8	Endian Format	387
11.9.9	Points for Caution when Overwriting DTCER	388

Section 12	I/O Ports	389
12.1	Register Descriptions	396
12.1.1	Data Direction Register (PnDDR) (n = 1, 2, 3, 6, A, B, D, E, F, and H to K) ..	397
12.1.2	Data Register (PnDR) (n = 1, 2, 3, 6, A, B, D, E, F, and H to K)	398
12.1.3	Port Register (PORTn) (n = 1, 2, 3, 5, 6, A, B, D, E, F, and H to K)	398
12.1.4	Input Buffer Control Register (PnICR) (n = 1, 2, 3, 5, 6, A, B, D, E, F, and H to K)	399
12.1.5	Pull-Up MOS Control Register (PnPCR) (n = D to F and H to K)	400
12.1.6	Open-Drain Control Register (PnODR) (n = 2 and F)	401
12.2	Output Buffer Control	401
12.2.1	Port 1	402
12.2.2	Port 2	406
12.2.3	Port 3	410
12.2.4	Port 5	414
12.2.5	Port 6	414
12.2.6	Port A	417
12.2.7	Port B	422
12.2.8	Port D	424
12.2.9	Port E	425
12.2.10	Port F	426
12.2.11	Port H	430
12.2.12	Port I	431
12.2.13	Port J	432
12.2.14	Port K	436
12.3	Port Function Controller	449
12.3.1	Port Function Control Register 0 (PFCR0)	450
12.3.2	Port Function Control Register 1 (PFCR1)	450
12.3.3	Port Function Control Register 2 (PFCR2)	452
12.3.4	Port Function Control Register 4 (PFCR4)	453
12.3.5	Port Function Control Register 6 (PFCR6)	455
12.3.6	Port Function Control Register 7 (PFCR7)	456
12.3.7	Port Function Control Register 9 (PFCR9)	457
12.3.8	Port Function Control Register A (PFCRA)	459
12.3.9	Port Function Control Register B (PFCRB)	461
12.3.10	Port Function Control Register C (PFCRC)	463
12.3.11	Port Function Control Register D (PFCRD)	464
12.4	Usage Notes	465
12.4.1	Notes on Input Buffer Control Register (ICR) Setting	465
12.4.2	Notes on Port Function Control Register (PFCR) Settings	465

Section 13	16-Bit Timer Pulse Unit (TPU)	467
13.1	Features	467
13.2	Input/Output Pins	474
13.3	Register Descriptions	476
13.3.1	Timer Control Register (TCR)	481
13.3.2	Timer Mode Register (TMDR)	486
13.3.3	Timer I/O Control Register (TIOR)	488
13.3.4	Timer Interrupt Enable Register (TIER)	506
13.3.5	Timer Status Register (TSR)	507
13.3.6	Timer Counter (TCNT)	511
13.3.7	Timer General Register (TGR)	511
13.3.8	Timer Start Register (TSTR)	512
13.3.9	Timer Synchronous Register (TSYR)	513
13.4	Operation	514
13.4.1	Basic Functions	514
13.4.2	Synchronous Operation	520
13.4.3	Buffer Operation	522
13.4.4	Cascaded Operation	526
13.4.5	PWM Modes	528
13.4.6	Phase Counting Mode	533
13.5	Interrupt Sources	540
13.6	DTC Activation	542
13.7	DMAC Activation	542
13.8	A/D Converter Activation	543
13.9	Operation Timing	543
13.9.1	Input/Output Timing	543
13.9.2	Interrupt Signal Timing	547
13.10	Usage Notes	551
13.10.1	Module Stop Function Setting	551
13.10.2	Input Clock Restrictions	551
13.10.3	Caution on Cycle Setting	552
13.10.4	Conflict between TCNT Write and Clear Operations	552
13.10.5	Conflict between TCNT Write and Increment Operations	553
13.10.6	Conflict between TGR Write and Compare Match	553
13.10.7	Conflict between Buffer Register Write and Compare Match	554
13.10.8	Conflict between TGR Read and Input Capture	554
13.10.9	Conflict between TGR Write and Input Capture	555
13.10.10	Conflict between Buffer Register Write and Input Capture	556
13.10.11	Conflict between Overflow/Underflow and Counter Clearing	557
13.10.12	Conflict between TCNT Write and Overflow/Underflow	557

13.10.13	Multiplexing of I/O Pins	558
13.10.14	PPG1 Setting when TPU1 Pin is Used.....	558
13.10.15	Interrupts and Module Stop Mode	558
Section 14 Programmable Pulse Generator (PPG)		559
14.1	Features.....	559
14.2	Input/Output Pins	562
14.3	Register Descriptions	564
14.3.1	Next Data Enable Registers H, L (NDERH, NDERL)	565
14.3.2	Output Data Registers H, L (PODRH, PODRL).....	567
14.3.3	Next Data Registers H, L (NDRH, NDRL)	570
14.3.4	PPG Output Control Register (PCR)	575
14.3.5	PPG Output Mode Register (PMR)	577
14.4	Operation	581
14.4.1	Output Timing.....	581
14.4.2	Sample Setup Procedure for Normal Pulse Output.....	582
14.4.3	Example of Normal Pulse Output (Example of 5-Phase Pulse Output).....	584
14.4.4	Non-Overlapping Pulse Output.....	585
14.4.5	Sample Setup Procedure for Non-Overlapping Pulse Output	587
14.4.6	Example of Non-Overlapping Pulse Output (Example of 4-Phase Complementary Non-Overlapping Pulse Output).....	589
14.4.7	Inverted Pulse Output	591
14.4.8	Pulse Output Triggered by Input Capture	592
14.5	Usage Notes	593
14.5.1	Module Stop State Setting	593
14.5.2	Operation of Pulse Output Pins.....	593
14.5.3	TPU Setting when PPG1 is in Use.....	593
Section 15 8-Bit Timers (TMR).....		595
15.1	Features.....	595
15.2	Input/Output Pins	600
15.3	Register Descriptions	601
15.3.1	Timer Counter (TCNT).....	603
15.3.2	Time Constant Register A (TCORA).....	603
15.3.3	Time Constant Register B (TCORB)	604
15.3.4	Timer Control Register (TCR).....	604
15.3.5	Timer Counter Control Register (TCCR)	606
15.3.6	Timer Control/Status Register (TCSR).....	611
15.4	Operation	615
15.4.1	Pulse Output.....	615

15.4.2	Reset Input.....	616
15.5	Operation Timing.....	617
15.5.1	TCNT Count Timing	617
15.5.2	Timing of CMFA and CMFB Setting at Compare Match	618
15.5.3	Timing of Timer Output at Compare Match.....	618
15.5.4	Timing of Counter Clear by Compare Match	619
15.5.5	Timing of TCNT External Reset.....	619
15.5.6	Timing of Overflow Flag (OVF) Setting	620
15.6	Operation with Cascaded Connection.....	620
15.6.1	16-Bit Counter Mode	620
15.6.2	Compare Match Count Mode.....	621
15.7	Interrupt Sources.....	621
15.7.1	Interrupt Sources and DTC Activation	621
15.7.2	A/D Converter Activation.....	622
15.8	Usage Notes	623
15.8.1	Notes on Setting Cycle	623
15.8.2	Conflict between TCNT Write and Counter Clear	623
15.8.3	Conflict between TCNT Write and Increment.....	624
15.8.4	Conflict between TCOR Write and Compare Match.....	624
15.8.5	Conflict between Compare Matches A and B.....	625
15.8.6	Switching of Internal Clocks and TCNT Operation	625
15.8.7	Mode Setting with Cascaded Connection	627
15.8.8	Module Stop State Setting	627
15.8.9	Interrupts in Module Stop State	627
Section 16 Watchdog Timer (WDT)		629
16.1	Features.....	629
16.2	Input/Output Pin	630
16.3	Register Descriptions.....	631
16.3.1	Timer Counter (TCNT).....	631
16.3.2	Timer Control/Status Register (TCSR).....	631
16.3.3	Reset Control/Status Register (RSTCSR).....	633
16.4	Operation	634
16.4.1	Watchdog Timer Mode.....	634
16.4.2	Interval Timer Mode.....	636
16.5	Interrupt Source	636
16.6	Usage Notes	637
16.6.1	Notes on Register Access	637
16.6.2	Conflict between Timer Counter (TCNT) Write and Increment.....	638
16.6.3	Changing Values of Bits CKS2 to CKS0.....	638

16.6.4	Switching between Watchdog Timer Mode and Interval Timer Mode.....	638
16.6.5	Internal Reset in Watchdog Timer Mode.....	639
16.6.6	System Reset by <u>WDTOVF</u> Signal.....	639
16.6.7	Transition to Watchdog Timer Mode or Software Standby Mode.....	639
Section 17 Serial Communication Interface (SCI, IrDA, CRC).....		641
17.1	Features.....	641
17.2	Input/Output Pins.....	646
17.3	Register Descriptions.....	647
17.3.1	Receive Shift Register (RSR).....	649
17.3.2	Receive Data Register (RDR).....	649
17.3.3	Transmit Data Register (TDR).....	650
17.3.4	Transmit Shift Register (TSR).....	650
17.3.5	Serial Mode Register (SMR).....	650
17.3.6	Serial Control Register (SCR).....	654
17.3.7	Serial Status Register (SSR).....	660
17.3.8	Smart Card Mode Register (SCMR).....	668
17.3.9	Bit Rate Register (BRR).....	669
17.3.10	Serial Extended Mode Register (SEMR_2).....	676
17.3.11	Serial Extended Mode Register 5 and 6 (SEMR_5 and SEMR_6).....	678
17.3.12	IrDA Control Register (IrCR).....	685
17.4	Operation in Asynchronous Mode.....	686
17.4.1	Data Transfer Format.....	687
17.4.2	Receive Data Sampling Timing and Reception Margin in Asynchronous Mode.....	688
17.4.3	Clock.....	689
17.4.4	SCI Initialization (Asynchronous Mode).....	690
17.4.5	Serial Data Transmission (Asynchronous Mode).....	691
17.4.6	Serial Data Reception (Asynchronous Mode).....	693
17.5	Multiprocessor Communication Function.....	697
17.5.1	Multiprocessor Serial Data Transmission.....	699
17.5.2	Multiprocessor Serial Data Reception.....	700
17.6	Operation in Clock Synchronous Mode.....	703
17.6.1	Clock.....	703
17.6.2	SCI Initialization (Clock Synchronous Mode).....	704
17.6.3	Serial Data Transmission (Clock Synchronous Mode).....	705
17.6.4	Serial Data Reception (Clock Synchronous Mode).....	707
17.6.5	Simultaneous Serial Data Transmission and Reception (Clock Synchronous Mode).....	708
17.7	Operation in Smart Card Interface Mode.....	710

17.7.1	Sample Connection	710
17.7.2	Data Format (Except in Block Transfer Mode)	711
17.7.3	Block Transfer Mode	712
17.7.4	Receive Data Sampling Timing and Reception Margin	713
17.7.5	Initialization	714
17.7.6	Data Transmission (Except in Block Transfer Mode)	715
17.7.7	Serial Data Reception (Except in Block Transfer Mode)	718
17.7.8	Clock Output Control	719
17.8	IrDA Operation	721
17.9	Interrupt Sources	724
17.9.1	Interrupts in Normal Serial Communication Interface Mode	724
17.9.2	Interrupts in Smart Card Interface Mode	725
17.10	Usage Notes	727
17.10.1	Module Stop State Setting	727
17.10.2	Break Detection and Processing	727
17.10.3	Mark State and Break Detection	727
17.10.4	Receive Error Flags and Transmit Operations (Clock Synchronous Mode Only)	727
17.10.5	Relation between Writing to TDR and TDRE Flag	728
17.10.6	Restrictions on Using DTC or DMAC	728
17.10.7	SCI Operations during Power-Down State	729
17.11	CRC Operation Circuit	732
17.11.1	Features	732
17.11.2	Register Descriptions	733
17.11.3	CRC Operation Circuit Operation	735
17.11.4	Note on CRC Operation Circuit	738
Section 18 I²C Bus Interface 2 (IIC2)		739
18.1	Features	739
18.2	Input/Output Pins	741
18.3	Register Descriptions	742
18.3.1	I ² C Bus Control Register A (ICCRA)	743
18.3.2	I ² C Bus Control Register B (ICCRB)	744
18.3.3	I ² C Bus Mode Register (ICMR)	746
18.3.4	I ² C Bus Interrupt Enable Register (ICIER)	747
18.3.5	I ² C Bus Status Register (ICSR)	750
18.3.6	Slave Address Register (SAR)	753
18.3.7	I ² C Bus Transmit Data Register (ICDRT)	754
18.3.8	I ² C Bus Receive Data Register (ICDRR)	754
18.3.9	I ² C Bus Shift Register (ICDRS)	754

18.4	Operation	755
18.4.1	I ² C Bus Format.....	755
18.4.2	Master Transmit Operation	756
18.4.3	Master Receive Operation.....	758
18.4.4	Slave Transmit Operation	760
18.4.5	Slave Receive Operation.....	763
18.4.6	Noise Canceler.....	764
18.4.7	Example of Use.....	765
18.5	Interrupt Request.....	769
18.6	Bit Synchronous Circuit.....	769
18.7	Usage Notes	770
Section 19 A/D Converter.....		773
19.1	Features.....	773
19.2	Input/Output Pins	776
19.3	Register Descriptions	777
19.3.1	A/D Data Registers A to H (ADDRA to ADDRH)	778
19.3.2	A/D Control/Status Register for Unit 0 (ADCSR_0).....	779
19.3.3	A/D Control/Status Register for Unit 1 (ADCSR_1).....	781
19.3.4	A/D Control Register for Unit 0 (ADCR_0).....	783
19.3.5	A/D Control Register for Unit 1 (ADCR_1).....	785
19.4	Operation	787
19.4.1	Single Mode.....	787
19.4.2	Scan Mode	788
19.4.3	Input Sampling and A/D Conversion Time	791
19.4.4	External Trigger Input Timing.....	793
19.5	Interrupt Source	795
19.6	A/D Conversion Accuracy Definitions	796
19.7	Usage Notes	798
19.7.1	Module Stop Function Setting	798
19.7.2	A/D Input Hold Function in Software Standby Mode	798
19.7.3	Notes on A/D Activation by an External Trigger	798
19.7.4	Permissible Signal Source Impedance	800
19.7.5	Influences on Absolute Accuracy	800
19.7.6	Setting Range of Analog Power Supply and Other Pins.....	801
19.7.7	Notes on Board Design	801
19.7.8	Notes on Noise Countermeasures	801

Section 20	D/A Converter	803
20.1	Features.....	803
20.2	Input/Output Pins.....	804
20.3	Register Descriptions.....	804
20.3.1	D/A Data Registers 0 and 1 (DADR0 and DADR1).....	804
20.3.2	D/A Control Register 01 (DACR01)	805
20.4	Operation	807
20.5	Usage Notes	808
20.5.1	Module Stop State Setting	808
20.5.2	D/A Output Hold Function in Software Standby Mode.....	808
20.5.3	Notes on Deep Software Standby Mode.....	808
Section 21	RAM	809
Section 22	Flash Memory.....	811
22.1	Features.....	811
22.2	Mode Transition Diagram.....	814
22.3	Memory MAT Configuration	816
22.4	Block Structure	817
22.4.1	Block Diagram of H8SX/1632.....	817
22.4.2	Block Diagram of H8SX/1634.....	818
22.4.3	Block Diagram of H8SX/1638.....	819
22.5	Programming/Erasing Interface	820
22.6	Input/Output Pins.....	822
22.7	Register Descriptions.....	822
22.7.1	Programming/Erasing Interface Registers	823
22.7.2	Programming/Erasing Interface Parameters	830
22.7.3	RAM Emulation Register (RAMER).....	842
22.8	On-Board Programming Mode	843
22.8.1	Boot Mode	843
22.8.2	User Program Mode.....	847
22.8.3	User Boot Mode.....	857
22.8.4	On-Chip Program and Storable Area for Program Data	861
22.9	Protection.....	867
22.9.1	Hardware Protection	867
22.9.2	Software Protection.....	868
22.9.3	Error Protection	868
22.10	Flash Memory Emulation Using RAM.....	870
22.11	Switching between User MAT and User Boot MAT.....	873

22.12	Programmer Mode	874
22.13	Standard Serial Communication Interface Specifications for Boot Mode	874
22.14	Usage Notes	903
Section 23 Boundary Scan		905
23.1	Features	905
23.2	Block Diagram of Boundary Scan Function	906
23.3	Pin Configuration	906
23.4	Register Descriptions	907
23.4.1	Instruction Register (JTIR)	908
23.4.2	Bypass Register (JTBPR)	909
23.4.3	Boundary Scan Register (JTBSR).....	910
23.4.4	IDCODE Register (JTID)	917
23.5	Operations.....	918
23.5.1	TAP Controller	918
23.5.2	Commands	919
23.6	Usage Notes	921
Section 24 Clock Pulse Generator		923
24.1	Register Description	924
24.1.1	System Clock Control Register (SCKCR)	924
24.2	Oscillator.....	927
24.2.1	Connecting Crystal Resonator	927
24.2.2	External Clock Input.....	928
24.3	PLL Circuit	929
24.4	Frequency Divider	929
24.5	Usage Notes	929
24.5.1	Notes on Clock Pulse Generator	929
24.5.2	Notes on Resonator	930
24.5.3	Notes on Board Design	930
Section 25 Power-Down Modes		933
25.1	Features.....	933
25.2	Register Descriptions	937
25.2.1	Standby Control Register (SBYCR)	937
25.2.2	Module Stop Control Registers A and B (MSTPCRA and MSTPCRB)	940
25.2.3	Module Stop Control Register C (MSTPCRC).....	943
25.2.4	Deep Standby Control Register (DPSBYCR).....	945
25.2.5	Deep Standby Wait Control Register (DPSWCR).....	947
25.2.6	Deep Standby Interrupt Enable Register (DPSIER)	949

25.2.7	Deep Standby Interrupt Flag Register (DPSIFR).....	951
25.2.8	Deep Standby Interrupt Edge Register (DPSIEGR)	953
25.2.9	Reset Status Register (RSTSR).....	954
25.2.10	Deep Standby Backup Register (DPSBKRn)	956
25.3	Multi-Clock Function	956
25.4	Module Stop State.....	957
25.5	Sleep Mode.....	958
25.5.1	Entry to Sleep Mode	958
25.5.2	Exit from Sleep Mode.....	958
25.6	All-Module-Clock-Stop Mode.....	959
25.7	Software Standby Mode.....	960
25.7.1	Entry to Software Standby Mode.....	960
25.7.2	Exit from Software Standby Mode	960
25.7.3	Setting Oscillation Settling Time after Exit from Software Standby Mode.....	961
25.7.4	Software Standby Mode Application Example.....	963
25.8	Deep Software Standby Mode	964
25.8.1	Transition to Deep Software Standby Mode.....	964
25.8.2	Exit from Deep Software Standby Mode.....	965
25.8.3	Pin State on Exit from Deep Software Standby Mode.....	966
25.8.4	B ϕ Operation after Exit from Deep Software Standby Mode.....	967
25.8.5	Setting Oscillation Settling Time after Exit from Deep Software Standby Mode	968
25.8.6	Deep Software Standby Mode Application Example	970
25.8.7	Flowchart of Deep Software Standby Mode Operation.....	974
25.9	Hardware Standby Mode	976
25.9.1	Transition to Hardware Standby Mode.....	976
25.9.2	Clearing Hardware Standby Mode.....	976
25.9.3	Hardware Standby Mode Timing.....	976
25.9.4	Timing Sequence at Power-On	977
25.10	Sleep Instruction Exception Handling	978
25.11	B ϕ Clock Output Control.....	981
25.12	Usage Notes	982
25.12.1	I/O Port Status.....	982
25.12.2	Current Consumption during Oscillation Settling Standby Period	982
25.12.3	Module Stop State of DMAC or DTC	982
25.12.4	On-Chip Peripheral Module Interrupts	982
25.12.5	Writing to MSTPCRA, MSTPCRB, and MSTPCRC	982
25.12.6	Control of Input Buffers by DIRQnE (n = 3 to 0).....	983
25.12.7	Conflict between a transition to deep software standby mode and interrupts	983

25.12.8	B ϕ Output State.....	983
Section 26	List of Registers	985
26.1	Register Addresses (Address Order).....	986
26.2	Register Bits.....	1003
26.3	Register States in Each Operating Mode	1027
Section 27	Electrical Characteristics	1043
27.1	Absolute Maximum Ratings	1043
27.2	DC Characteristics (H8SX/1638 Group)	1044
27.3	DC Characteristics (H8SX/1638L Group).....	1047
27.4	AC Characteristics	1050
27.4.1	Clock Timing	1050
27.4.2	Control Signal Timing	1053
27.4.3	Bus Timing	1054
27.4.4	DMAC Timing.....	1069
27.4.5	Timing of On-Chip Peripheral Modules	1072
27.5	A/D Conversion Characteristics	1080
27.6	D/A Conversion Characteristics	1080
27.7	Flash Memory Characteristics	1081
27.8	Power-On Reset Circuit and Voltage-Detection Circuit Characteristics (H8SX/1638L Group).....	1082
Appendix		1085
A.	Port States in Each Pin State	1085
B.	Product Lineup.....	1090
C.	Package Dimensions	1091
D.	Treatment of Unused Pins.....	1092
Main Revisions and Additions in this Edition		1095
Index		1125

Section 1 Overview

1.1 Features

The core of each product in the H8SX/1638 Group and H8SX/1638L Group of CISC (complex instruction set computer) microcontrollers is an H8SX CPU, which has an internal 32-bit architecture. The H8SX CPU provides upward-compatibility with the CPUs of other Renesas Technology-original microcontrollers; H8/300, H8/300H, and H8S.

As peripheral functions, each LSI of the Group includes a DMA controller, which enables high-speed data transfer, and a bus-state controller, which enables direct connection to different kinds of memory. The LSI of the Group also includes serial communication interfaces, A/D and D/A converters, and a multi-function timer that makes motor control easy. Together, the modules realize low-cost configurations for end systems. The power consumption of these modules is kept down dynamically by an on-chip power-management function. The on-chip ROM is a flash memory (F-ZTAT™*) with a capacity of 1024 Kbytes (H8SX/1638 and H8SX/1638L), 512 Kbytes (H8SX/1634 and H8SX/1634L) or 256 Kbytes (H8SX/1632 and H8SX/1632L).

Note: * F-ZTAT™ is a trademark of Renesas Technology Corp.

1.1.1 Applications

Examples of the applications of this LSI include PC peripheral equipment, optical storage devices, office automation equipment, and industrial equipment.

1.1.2 Overview of Functions

Table 1.1 lists the functions of H8SX/1638 Group and H8SX/1638L Group products in outline.

Table 1.1 Overview of Functions

Classification	Module/ Function	Description
Memory	ROM	<ul style="list-style-type: none"> ROM capacity: 1024 Kbytes, 512 Kbytes or 256 Kbytes
	RAM	<ul style="list-style-type: none"> RAM capacity: 56 Kbytes, 40 Kbytes or 24 Kbytes
CPU	CPU	<ul style="list-style-type: none"> 32-bit high-speed H8SX CPU (CISC type) Upwardly compatible for H8/300, H8/300H, and H8S CPUs at object level General-register architecture (sixteen 16-bit general registers) 11 addressing modes 4-Gbyte address space Program: 4 Gbytes available Data: 4 Gbytes available 87 basic instructions, classifiable as bit arithmetic and logic instructions, multiply and divide instructions, bit manipulation instructions, multiply-and-accumulate instructions, and others Minimum instruction execution time: 20.0 ns (for an ADD instruction while system clock $f_{\phi} = 50$ MHz and $V_{cc} = 3.0$ to 3.6 V) On-chip multiplier ($16 \times 16 \rightarrow 32$ bits) Supports multiply-and-accumulate instructions ($16 \times 16 + 42 \rightarrow 42$ bits)
		Operating mode

Classification	Module/ Function	Description
CPU	MCU operating mode	<p>Mode 1: User boot mode (selected by driving the MD2 and MD1 pins low and driving the MD0 pin high)</p> <p>Mode 2: Boot mode (selected by driving the MD2 and MD0 pins low and driving the MD1 pin high)</p> <p>Mode 3: Boundary scan enabled single-chip mode (selected by driving the MD2 pin low and driving the MD1 and MD0 pins high)</p> <p>Mode 4: On-chip ROM disabled external extended mode, 16-bit bus (selected by driving the MD1 and MD0 pins low and driving the MD2 pin high)</p> <p>Mode 5: On-chip ROM disabled external extended mode, 8-bit bus (selected by driving the MD1 pin low and driving the MD2 and MD0 pins high)</p> <p>Mode 6: On-chip ROM enabled external extended mode (selected by driving the MD0 pin low and driving the MD2 and MD1 pins high)</p> <p>Mode 7: Single-chip mode (can be externally extended) (selected by driving the MD2, MD1, and MD0 pins high)</p> <ul style="list-style-type: none"> • Low power consumption state (transition driven by the SLEEP instruction)
Power on reset*		<ul style="list-style-type: none"> • At power-on or low power supply voltage, an internal reset signal is generated
Voltage detection circuit (LVD)*		<ul style="list-style-type: none"> • At low power supply voltage, an internal reset signal and an interrupt are generated
Interrupt (source)	Interrupt controller (INTC)	<ul style="list-style-type: none"> • 17 external interrupt pins (NMI, and $\overline{IRQ15}$ to $\overline{IRQ0}$) • 109 internal interrupt sources H8SX/1638 Group: 110 pins H8SX/1638L Group: 111 pins • 2 interrupt control modes (specified by the interrupt control register) • 8 priority orders specifiable (by setting the interrupt priority register) • Independent vector addresses

Classification	Module/ Function	Description
Interrupt (source)	Break interrupt (UBC)	<ul style="list-style-type: none"> • Break point can be set for four channels • Address break can be set for CPU instruction fetch cycles
DMA	DMA controller (DMAC)	<ul style="list-style-type: none"> • 4-channel DMA transfer available • 3 activation methods (auto-request, on-chip module interrupt, external request) • 3 transfer modes (normal transfer, repeat transfer, block transfer) • Dual or single address mode selectable • Extended repeat-area function
	Data transfer controller (DTC)	<ul style="list-style-type: none"> • Allows DMA transfer over 76 channels (number of DTC activation sources) • Activated by interrupt sources (chain transfer enabled) • 3 transfer modes (normal transfer, repeat transfer, block transfer) • Short-address mode or full-address mode selectable
External bus extension	Bus controller (BSC)	<ul style="list-style-type: none"> • 16-Mbyte external address space • The external address space can be divided into 8 areas, each of which is independently controllable <ul style="list-style-type: none"> — Chip-select signals ($\overline{CS0}$ to $\overline{CS7}$) can be output — Access in 2 or 3 states can be selected for each area — Program wait cycles can be inserted — The period of \overline{CS} assertion can be extended — Idle cycles can be inserted • Bus arbitration function (arbitrates bus mastership among the internal CPU and DTC, and external bus masters) <p>Bus formats</p> <ul style="list-style-type: none"> • External memory interfaces (for the connection of ROM, burst ROM, SRAM, and byte control SRAM) • Address/data bus format: Support for both separate and multiplexed buses (8-bit access or 16-bit access) • Endian conversion function for connecting devices in little-endian format

Classification	Module/ Function	Description
Clock	Clock pulse generator (CPG)	<ul style="list-style-type: none"> • 1 clock generation circuit available • Separate clock signals are provided for each of functional modules (detailed below) and each is independently specifiable (multi-clock function) <ul style="list-style-type: none"> — System-intended data transfer modules, i.e. the CPU, runs in synchronization with the system clock ($I\phi$): 8 to 50 MHz — Internal peripheral functions run in synchronization with the peripheral module clock ($P\phi$): 8 to 35 MHz — Modules in the external space are supplied with the external bus clock ($B\phi$): 8 to 50 MHz • Includes a PLL frequency multiplication circuit and frequency divider, so the operating frequency is selectable • 5 low-power-consumption modes: Sleep mode, all-module-clock-stop mode, software standby mode, deep software standby mode, and hardware standby mode
A/D converter	A/D converter (ADC)	<ul style="list-style-type: none"> • 10-bit resolution \times 2 units • Selectable input channel and unit configuration 4 channels \times 2 units (units 0 and 1) 8 channels \times one unit (unit 0) • Sample and hold function included • Conversion time: 2.7 μs per channel (with peripheral module clock ($P\phi$) at 25-MHz operation) • 2 operating modes: single mode and scan mode • 3 ways to start A/D conversion: <ul style="list-style-type: none"> Unit 0: Software, timer (TPU/TMR (units 0 and 1)) trigger, and external trigger Unit 1: Software, TMR (units 2 and 3) trigger, and external trigger • Activation of DTC and DMAC by ADI interrupt: <ul style="list-style-type: none"> Unit 0: DTC and DMAC can be activated by an ADI interrupt. Unit 1: DMAC can be activated by an ADI1 interrupt.

Classification	Module/ Function	Description
D/A converter	D/A converter (DAC)	<ul style="list-style-type: none"> 8-bit resolution × 2 output channels Output voltage: 0 V to Vref, maximum conversion time: 10 μs (with 20-pF load)
Timer	8-bit timer (TMR)	<ul style="list-style-type: none"> 8 bits × 8 channels (can be used as 16 bits × four channels) Select from among 7 clock sources (6 internal clocks and 1 external clock) Allows the output of pulse trains with a desired duty cycle or PWM signals
	16-bit timer pulse unit (TPU)	<ul style="list-style-type: none"> 16 bits × 12* channels (general pulse timer unit) Select from among 8 counter-input clocks for each channel Up to 16 pulse inputs and outputs Counter clear operation, simultaneous writing to multiple timer counters (TCNT), simultaneous clearing by compare match and input capture possible, simultaneous input/output for registers possible by counter synchronous operation, and up to 15-phase PWM output possible by combination with synchronous operation Buffered operation, cascaded operation (32 bits × two channels), and phase counting mode (two-phase encoder input) settable for each channel Input capture function supported Output compare function (by the output of compare match waveform) supported <p>Note: * Pin function of unit 1 cannot be used in the external bus extended mode.</p>
	Program-mable pulse generator (PPG)	<ul style="list-style-type: none"> 32-bit*¹*² pulse output 4 output groups, non-overlapping mode, and inverted output can be set Selectable output trigger signals; the PPG can operate in conjunction with the data transfer controller (DTC) and the DMA controller (DMAC) <p>Notes: 1. Pulse output pins PO31 to PO16 cannot be activated by input capture. 2. Pulse of unit 1 cannot be output in the external bus extended mode.</p>
Watchdog timer	Watchdog timer (WDT)	<ul style="list-style-type: none"> 8 bits × one channels (selectable from eight counter input clocks) Switchable between watchdog timer mode and interval timer mode

Classification	Module/ Function	Description
Serial interface	Serial communications interface (SCI)	<ul style="list-style-type: none"> • 7 channels (select asynchronous or clock synchronous serial communications mode) • Full-duplex communications capability • Select the desired bit rate and LSB-first or MSB-first transfer • Transfer rate clock input from TMR (SCI_5, SCI_6) • IrDA transmission and reception conformant with the IrDA Specifications version 1.0 • On-chip cyclic redundancy check (CRC) calculator for improved reliability in data transfer
Smart card/SIM		<ul style="list-style-type: none"> • The SCI module supports a smart card (SIM) interface.
I ² C bus interface	I ² C bus interface 2 (IIC2)	<ul style="list-style-type: none"> • 2 channels • Bus can be directly driven (the SCL and SDA pins are NMOS open drains).
I/O ports		<ul style="list-style-type: none"> • 9 CMOS input-only pins • 81 CMOS input/output pins • 8 large-current drive pins (port 3) • 40 pull-up resistors • 16 open drains
Package		<ul style="list-style-type: none"> • LQFP-120 package
Operating frequency/ Power supply voltage		<ul style="list-style-type: none"> • Operating frequency: 8 to 50 MHz • Power supply voltage: V_{cc} = PLLV_{cc} = 3.0 to 3.6 V, AV_{cc} = 3.0 to 3.6 V • Flash programming/erasure voltage: 3.0 to 3.6 V • Supply current: <ul style="list-style-type: none"> — 50 mA (typ.) (V_{cc} = PLLV_{cc} = 3.0 V, AV_{cc} = 3.0 V, I_φ = B_φ = 50 MHz, P_φ = 25 MHz)
Operating peripheral temperature (°C)		<ul style="list-style-type: none"> • -20 to +75°C (regular specifications) • -40 to +85°C (wide-range specifications)
Note	* Supported only by the H8SX/1638L Group.	

Table 1.2 Comparison of Support Functions in the H8SX/1638 and H8SX/1638L Group.

Function		H8SX/1638 Group	H8SX/1638L Group
DMAC		○	○
DTC		○	○
PPG		○	○
UBC		○	○
SCI		○	○
IIC2		○	○
TMR		○	○
WDT		○	○
10-bit ADC		○	○
8-bit DAC		○	○
POR/LVD		—	○
Package	LQFP-144	○	○

1.2 List of Products

Table 1.3 is the list of products, and figure 1.1 shows how to read the product name code.

Table 1.3 List of Products

Group	Part No.	ROM Capacity	RAM Capacity	Package	Remarks
H8SX/1638	R5F61638N50FPV	1024 Kbytes	56 Kbytes	LQFP-120	Regular specifications
	R5F61634N50FPV	512 Kbytes	40 Kbytes	LQFP	
	R5F61632N50FPV	256 Kbytes	24 Kbytes	LQFP	
	R5F61638D50FPV	1024 Kbytes	56 Kbytes	LQFP	Wide range specifications
	R5F61634D50FPV	512 Kbytes	40 Kbytes	LQFP	
	R5F61632D50FPV	256 Kbytes	24 Kbytes	LQFP	
H8SX/1638L	R5F61638LN50FPV	1024 Kbytes	56 Kbytes	LQFP	Regular specifications
	R5F61634LN50FPV	512 Kbytes	40 Kbytes	LQFP	
	R5F61632LN50FPV	256 Kbytes	24 Kbytes	LQFP	
	R5F61638LD50FPV	1024 Kbytes	56 Kbytes	LQFP	Wide range specifications
	R5F61634LD50FPV	512 Kbytes	40 Kbytes	LQFP	
	R5F61632LD50FPV	256 Kbytes	24 Kbytes	LQFP	

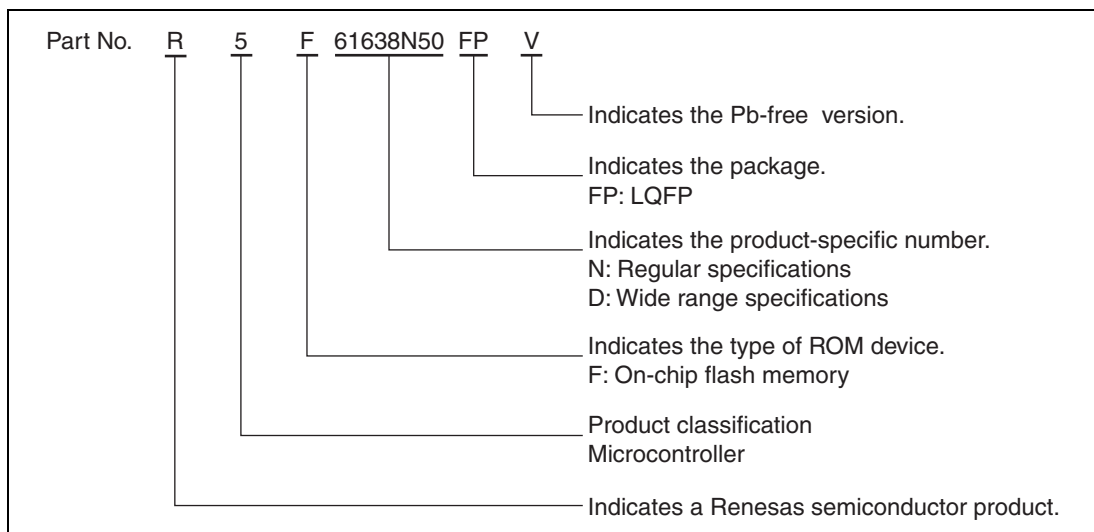

Figure 1.1 How to Read the Product Name Code

- Small Package

Package	Package Code	Body Size	Pin Pitch
LQFP-120	PLQP0120LA-A (FP-120BV)*	14.0 × 14.0 mm	0.40 mm

Note: * Pb-free version

1.3 Block Diagram

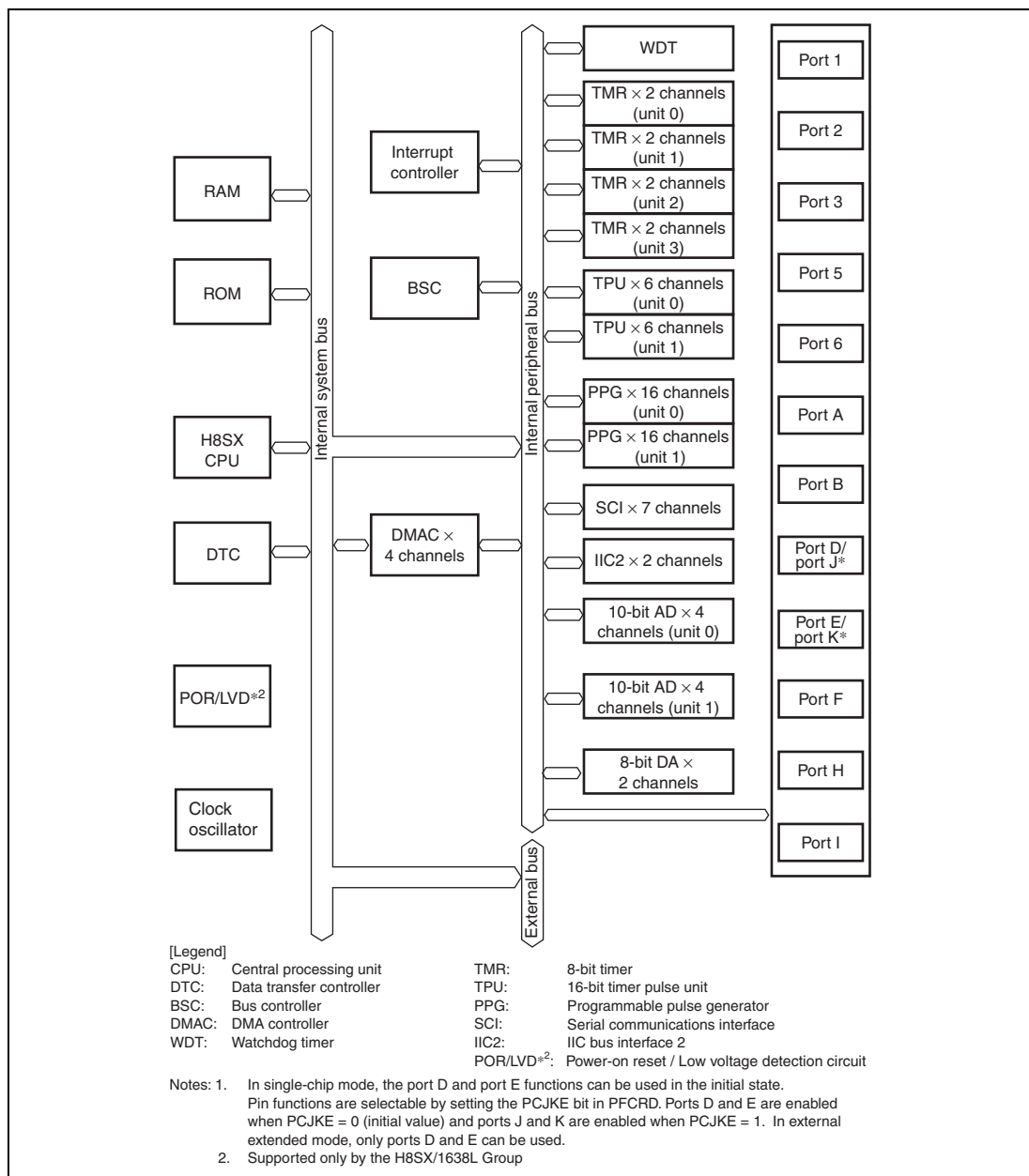

Figure 1.2 Block Diagram

1.4 Pin Assignments

1.4.1 Pin Assignments

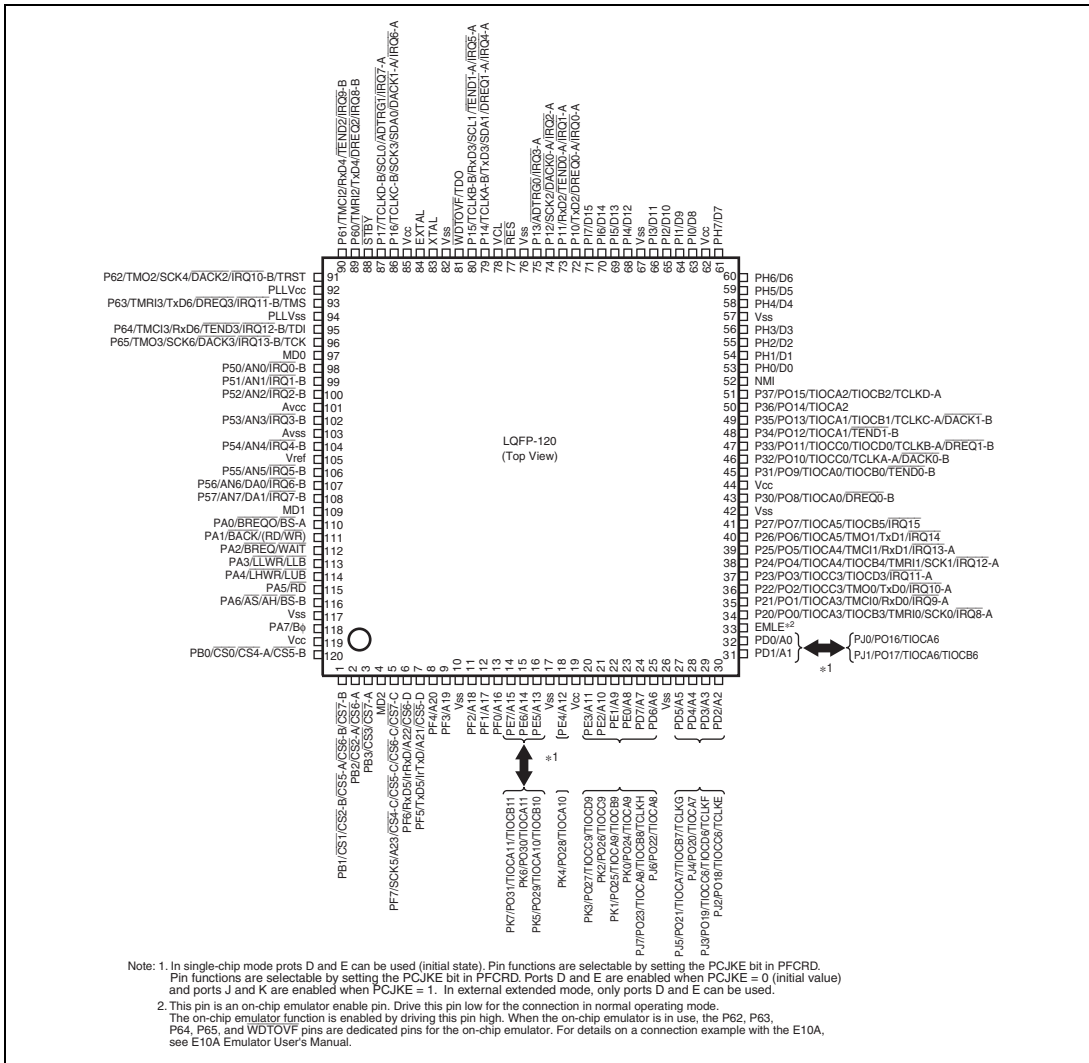

Figure 1.3 Pin Assignments

1.4.2 Correspondence between Pin Configuration and Operating Modes

Table 1.4 Pin Configuration in Each Operating Mode (H8SX/1638 Group and H8SX/1638L Group)

Pin No.	Pin Name		
	Modes 1, 2, and 6	Modes 3 and 7	Modes 4 and 5
1	PB1/ $\overline{\text{CS1}}$ / $\overline{\text{CS2}}$ -B/ $\overline{\text{CS5}}$ -A/ $\overline{\text{CS6}}$ -B/ $\overline{\text{CS7}}$ -B	PB1/ $\overline{\text{CS1}}$ / $\overline{\text{CS2}}$ -B/ $\overline{\text{CS5}}$ -A/ $\overline{\text{CS6}}$ -B/ $\overline{\text{CS7}}$ -B	PB1/ $\overline{\text{CS1}}$ / $\overline{\text{CS2}}$ -B/ $\overline{\text{CS5}}$ -A/ $\overline{\text{CS6}}$ - B/ $\overline{\text{CS7}}$ -B
2	PB2/ $\overline{\text{CS2}}$ -A/ $\overline{\text{CS6}}$ -A	PB2/ $\overline{\text{CS2}}$ -A/ $\overline{\text{CS6}}$ -A	PB2/ $\overline{\text{CS2}}$ -A/ $\overline{\text{CS6}}$ -A
3	PB3/ $\overline{\text{CS3}}$ / $\overline{\text{CS7}}$ -A	PB3/ $\overline{\text{CS3}}$ / $\overline{\text{CS7}}$ -A	PB3/ $\overline{\text{CS3}}$ / $\overline{\text{CS7}}$ -A
4	MD2	MD2	MD2
5	PF7/ $\overline{\text{SCK5}}$ / $\overline{\text{A23}}$ / $\overline{\text{CS4}}$ -C/ $\overline{\text{CS5}}$ -C/ $\overline{\text{CS6}}$ -C/ $\overline{\text{CS7}}$ -C	PF7/ $\overline{\text{SCK5}}$ / $\overline{\text{A23}}$ / $\overline{\text{CS4}}$ -C/ $\overline{\text{CS5}}$ -C/ $\overline{\text{CS6}}$ -C/ $\overline{\text{CS7}}$ -C	PF7/ $\overline{\text{SCK5}}$ / $\overline{\text{A23}}$ / $\overline{\text{CS4}}$ -C/ $\overline{\text{CS5}}$ -C/ $\overline{\text{CS6}}$ -C/ $\overline{\text{CS7}}$ -C
6	PF6/RxD5/IrRxD/A22/ $\overline{\text{CS6}}$ -D	PF6/RxD5/IrRxD/A22/ $\overline{\text{CS6}}$ -D	PF6/RxD5/IrRxD/A22/ $\overline{\text{CS6}}$ -D
7	PF5/TxD5/IrTxD/ A21/ $\overline{\text{CS5}}$ -D	PF5/TxD5/IrTxD/A21/ $\overline{\text{CS5}}$ -D	PF5/TxD5/IrTxD/A21/ $\overline{\text{CS5}}$ -D
8	PF4/A20	PF4/A20	PF4/A20
9	PF3/A19	PF3/A19	PF3/A19
10	Vss	Vss	Vss
11	PF2/A18	PF2/A18	PF2/A18
12	PF1/A17	PF1/A17	PF1/A17
13	PF0/A16	PF0/A16	PF0/A16
14	PE7/A15	PE7/A15 PK7/PO31/ TIOCA11/TIOCB11* ¹	A15
15	PE6/A14	PE6/A14 PK6/PO30/ TIOCA11* ¹	A14
16	PE5/A13	PE5/A13 PK5/PO29/ TIOCA10/TIOCB10* ¹	A13
17	Vss	Vss	Vss
18	PE4/A12	PE4/A12 PK4/PO28/TIOCA10* ¹	A12
19	Vcc	Vcc	Vcc
20	PE3/A11	PE3/A11 PK3/PO27/ TIOCC9/TIOCD9* ¹	A11
21	PE2/A10	PE2/A10 PK2/PO26/TIOCC9* ¹	A10

Pin No.	Pin Name		
	Modes 1, 2, and 6	Modes 3 and 7	Modes 4 and 5
22	PE1/A9	PE1/A9 PK1/PO25/ TIOCA9/TIOCB9* ¹	A9
23	PE0/A8	PE0/A8 PK0/PO24/TIOCA9* ¹	A8
24	PD7/A7	PD7/A7 PJ7/PO23/TIOCA8/ TIOCB8/TCLKH* ¹	A7
25	PD6/A6	PD6/A6 PJ6/PO22/TIOCA8* ¹	A6
26	Vss	Vss	Vss
27	PD5/A5	PD5/A5 PJ5/PO21/TIOCA7/ TIOCB7/TCLKG* ¹	A5
28	PD4/A4	PD4/A4 PJ4/PO20/TIOCA7* ¹	A4
29	PD3/A3	PD3/A3 PJ3/PO19/TIOCC6/ TIOCD6/TCLKF* ¹	A3
30	PD2/A2	PD2/A2 PJ2/PO18/ TIOCC6/TCLKE* ¹	A2
31	PD1/A1	PD1/A1 PJ1/PO17/ TIOCA6/TIOCB6* ¹	A1
32	PD0/A0	PD0/A0 PJ0/PO16/TIOCA6* ¹	A0
33	EMLE	EMLE	EMLE
34	P20/PO0/TIOCA3/TIOCB3/ TMRI0/SCK0/IRQ8-A	P20/PO0/TIOCA3/TIOCB3/ TMRI0/SCK0/IRQ8-A	P20/PO0/TIOCA3/TIOCB3/ TMRI0/SCK0/IRQ8-A
35	P21/PO1/TIOCA3/TMCI0/ RxD0/IRQ9-A	P21/PO1/TIOCA3/TMCI0/ RxD0/IRQ9-A	P21/PO1/TIOCA3/TMCI0/ RxD0/IRQ9-A
36	P22/PO2/TIOCC3/TMO0/ TxD0/IRQ10-A	P22/PO2/TIOCC3/TMO0/ TxD0/IRQ10-A	P22/PO2/TIOCC3/TMO0/ TxD0/IRQ10-A
37	P23/PO3/TIOCC3/TIOCD3/ IRQ11-A	P23/PO3/TIOCC3/TIOCD3/ IRQ11-A	P23/PO3/TIOCC3/TIOCD3/ IRQ11-A
38	P24/PO4/TIOCA4/TIOCB4/ TMRI1/SCK1/IRQ12-A	P24/PO4/TIOCA4/TIOCB4/ TMRI1/SCK1/IRQ12-A	P24/PO4/TIOCA4/TIOCB4/ TMRI1/SCK1/IRQ12-A
39	P25/PO5/TIOCA4/TMCI1/ RxD1/IRQ13-A	P25/PO5/TIOCA4/TMCI1/ RxD1/IRQ13-A	P25/PO5/TIOCA4/TMCI1/ RxD1/IRQ13-A
40	P26/PO6/TIOCA5/TMO1/ TxD1/IRQ14	P26/PO6/TIOCA5/TMO1/ TxD1/IRQ14	P26/PO6/TIOCA5/TMO1/ TxD1/IRQ14

Pin Name			
Pin No.	Modes 1, 2, and 6	Modes 3 and 7	Modes 4 and 5
41	P27/PO7/TIOCA5/ TIOCB5/ $\overline{\text{IRQ15}}$	P27/PO7/TIOCA5/TIOCB5/ $\overline{\text{IRQ15}}$	P27/PO7/TIOCA5/TIOCB5/ $\overline{\text{IRQ15}}$
42	Vss	Vss	Vss
43	P30/PO8/TIOCA0/ $\overline{\text{DREQ0-B}}$	P30/PO8/TIOCA0/ $\overline{\text{DREQ0-B}}$	P30/PO8/TIOCA0/ $\overline{\text{DREQ0-B}}$
44	Vcc	Vcc	Vcc
45	P31/PO9/TIOCA0/TIOCB0/ $\overline{\text{TEND0-B}}$	P31/PO9/TIOCA0/TIOCB0/ $\overline{\text{TEND0-B}}$	P31/PO9/TIOCA0/TIOCB0/ $\overline{\text{TEND0-B}}$
46	P32/PO10/TIOCC0/ TCLKA-A/ $\overline{\text{DACK0-B}}$	P32/PO10/TIOCC0/ TCLKA-A/ $\overline{\text{DACK0-B}}$	P32/PO10/TIOCC0/ TCLKA-A/ $\overline{\text{DACK0-B}}$
47	P33/PO11/TIOCC0/TIOCD0/ TCLKB-A/ $\overline{\text{DREQ1-B}}$	P33/PO11/TIOCC0/TIOCD0/ TCLKB-A/ $\overline{\text{DREQ1-B}}$	P33/PO11/TIOCC0/TIOCD0/ TCLKB-A/ $\overline{\text{DREQ1-B}}$
48	P34/PO12/TIOCA1/ $\overline{\text{TEND1-B}}$	P34/PO12/TIOCA1/ $\overline{\text{TEND1-B}}$	P34/PO12/TIOCA1/ $\overline{\text{TEND1-B}}$
49	P35/PO13/TIOCA1/TIOCB1/ TCLKC-A/ $\overline{\text{DACK1-B}}$	P35/PO13/TIOCA1/TIOCB1/ TCLKC-A/ $\overline{\text{DACK1-B}}$	P35/PO13/TIOCA1/TIOCB1/ TCLKC-A/ $\overline{\text{DACK1-B}}$
50	P36/PO14/TIOCA2	P36/PO14/TIOCA2	P36/PO14/TIOCA2
51	P37/PO15/TIOCA2/TIOCB2/ TCLKD-A	P37/PO15/TIOCA2/TIOCB2/ TCLKD-A	P37/PO15/TIOCA2/TIOCB2/ TCLKD-A
52	NMI	NMI	NMI
53	PH0/D0	PH0/D0	D0
54	PH1/D1	PH1/D1	D1
55	PH2/D2	PH2/D2	D2
56	PH3/D3	PH3/D3	D3
57	Vss	Vss	Vss
58	PH4/D4	PH4/D4	D4
59	PH5/D5	PH5/D5	D5
60	PH6/D6	PH6/D6	D6
61	PH7/D7	PH7/D7	D7
62	Vcc	Vcc	Vcc
63	PI0/D8	PI0/D8	PI0/D8
64	PI1/D9	PI1/D9	PI1/D9
65	PI2/D10	PI2/D10	PI2/D10
66	PI3/D11	PI3/D11	PI3/D11

Pin No.	Pin Name		
	Modes 1, 2, and 6	Modes 3 and 7	Modes 4 and 5
67	Vss	Vss	Vss
68	PI4/D12	PI4/D12	PI4/D12
69	PI5/D13	PI5/D13	PI5/D13
70	PI6/D14	PI6/D14	PI6/D14
71	PI7/D15	PI7/D15	PI7/D15
72	P10/TxD2/DREQ0-A/IRQ0-A	P10/TxD2/DREQ0-A/IRQ0-A	P10/TxD2/DREQ0-A/IRQ0-A
73	P11/RxD2/TEND0-A/IRQ1-A	P11/RxD2/TEND0-A/IRQ1-A	P11/RxD2/TEND0-A/IRQ1-A
74	P12/SCK2/DACK0-A/IRQ2-A	P12/SCK2/DACK0-A/IRQ2-A	P12/SCK2/DACK0-A/IRQ2-A
75	P13/ADTRG0/IRQ3-A	P13/ADTRG0/IRQ3-A	P13/ADTRG0/IRQ3-A
76	Vss	Vss	Vss
77	RES	RES	RES
78	VCL	VCL	VCL
79	P14/TCLKA-B/TxD3/SDA1/ DREQ1-A/IRQ4-A	P14/TCLKA-B/TxD3/SDA1/ DREQ1-A/IRQ4-A	P14/TCLKA-B/TxD3/SDA1/ DREQ1-A/IRQ4-A
80	P15/TCLKB-B/RxD3/SCL1/ TEND1-A/IRQ5-A	P15/TCLKB-B/RxD3/SCL1/ TEND1-A/IRQ5-A	P15/TCLKB-B/RxD3/SCL1/ TEND1-A/IRQ5-A
81	WDTOVF	WDTOVF/TDO* ²	WDTOVF
82	Vss	Vss	Vss
83	XTAL	XTAL	XTAL
84	EXTAL	EXTAL	EXTAL
85	Vcc	Vcc	Vcc
86	P16/TCLKC-B/SCK3/SDA0/ DACK1-A/IRQ6-A	P16/TCLKC-B/SCK3/SDA0/ DACK1-A/IRQ6-A	P16/TCLKC-B/SCK3/SDA0/ DACK1-A/IRQ6-A
87	P17/TCLKD-B/SCL0/ ADTRG1/IRQ7-A	P17/TCLKD-B/SCL0/ ADTRG1/IRQ7-A	P17/TCLKD-B/SCL0/ ADTRG1/IRQ7-A
88	STBY	STBY	STBY
89	P60/TMRI2/TxD4/ DREQ2/IRQ8-B	P60/TMRI2/TxD4/ DREQ2/IRQ8-B	P60/TMRI2/TxD4/ DREQ2/IRQ8-B
90	P61/TMC12/RxD4/ TEND2/IRQ9-B	P61/TMC12/RxD4/ TEND2/IRQ9-B	P61/TMC12/RxD4/ TEND2/IRQ9-B
91	P62/TMO2/SCK4/DACK2/ IRQ10-B	P62/TMO2/SCK4/DACK2/ IRQ10-B/TRST* ²	P62/TMO2/SCK4/DACK2/ IRQ10-B
92	PLLVcc	PLLVcc	PLLVcc

Pin No.	Pin Name		
	Modes 1, 2, and 6	Modes 3 and 7	Modes 4 and 5
93	P63/TMRI3/TxD6/DREQ3/ IRQ11-B	P63/TMRI3/TxD6/DREQ3/ IRQ11-B/TMS* ²	P63/TMRI3/TxD6/DREQ3/ IRQ11-B
94	PLLvss	PLLvss	PLLvss
95	P64/TMCI3/RxD6/TEND3/ IRQ12-B	P64/TMCI3/RxD6/TEND3/ IRQ12-B/TDI* ²	P64/TMCI3/RxD6/TEND3/ IRQ12-B
96	P65/TMO3/SCK6/DACK3/ IRQ13-B	P65/TMO3/SCK6/DACK3/ IRQ13-B/TCK* ²	P65/TMO3/SCK6/DACK3/ IRQ13-B
97	MD0	MD0	MD0
98	P50/AN0/IRQ0-B	P50/AN0/IRQ0-B	P50/AN0/IRQ0-B
99	P51/AN1/IRQ1-B	P51/AN1/IRQ1-B	P51/AN1/IRQ1-B
100	P52/AN2/IRQ2-B	P52/AN2/IRQ2-B	P52/AN2/IRQ2-B
101	Avcc	Avcc	Avcc
102	P53/AN3/IRQ3-B	P53/AN3/IRQ3-B	P53/AN3/IRQ3-B
103	Avss	Avss	Avss
104	P54/AN4/IRQ4-B	P54/AN4/IRQ4-B	P54/AN4/IRQ4-B
105	Vref	Vref	Vref
106	P55/AN5/IRQ5-B	P55/AN5/IRQ5-B	P55/AN5/IRQ5-B
107	P56/AN6/DA0/IRQ6-B	P56/AN6/DA0/IRQ6-B	P56/AN6/DA0/IRQ6-B
108	P57/AN7/DA1/IRQ7-B	P57/AN7/DA1/IRQ7-B	P57/AN7/DA1/IRQ7-B
109	MD1	MD1	MD1
110	PA0/BREQ/BS-A	PA0/BREQ/BS-A	PA0/BREQ/BS-A
111	PA1/BACK/(RD/WR)	PA1/BACK/(RD/WR)	PA1/BACK/(RD/WR)
112	PA2/BREQ/WAIT	PA2/BREQ/WAIT	PA2/BREQ/WAIT
113	PA3/LLWR/LLB	PA3/LLWR/LLB	LLWR/LLB
114	PA4/LHWR/LUB	PA4/LHWR/LUB	PA4/LHWR/LUB
115	PA5/RD	PA5/RD	RD
116	PA6/AS/AH/BS-B	PA6/AS/AH/BS-B	PA6/AS/AH/BS-B
117	Vss	Vss	Vss
118	PA7/B ϕ	PA7/B ϕ	PA7/B ϕ
119	Vcc	Vcc	Vcc
120	PB0/CS0/CS4-A/CS5-B	PB0/CS0/CS4-A/CS5-B	PB0/CS0/CS4-A/CS5-B

- Notes: 1. These pins can be used when the PCJKE bit in PFCRD is set to 1 in single-chip mode.
2. Pins TDO, TRST, TMS, TDI, and TCK are enabled in mode 3.

1.4.3 Pin Functions

Table 1.5 Pin Functions

Classification	Pin Name	I/O	Description
Power supply	V_{CC}	Input	Power supply pins. Connect them to the system power supply.
	V_{CL}	Input	Connect this pin to V_{SS} via a 0.1- μ F capacitor (The capacitor should be placed close to the pin).
	V_{SS}	Input	Ground pins. Connect them to the system power supply (0 V).
	$PLL_{V_{CC}}$	Input	Power supply pin for the PLL circuit.
	$PLL_{V_{SS}}$	Input	Ground pin for the PLL circuit.
Clock	XTAL	Input	Pins for a crystal resonator. An external clock signal can be input through the EXTAL pin. For an example of this connection, see section 24, Clock Pulse Generator.
	EXTAL	Input	
	$B\phi$	Output	Outputs the system clock for external devices.
Operating mode control	MD2 to MD0	Input	Pins for setting the operating mode. The signal levels on these pins must not be changed during operation.
System control	\overline{RES}	Input	Reset signal input pin. This LSI enters the reset state when this signal goes low.
	\overline{STBY}	Input	This LSI enters hardware standby mode when this signal goes low.
	EMLE	Input	Input pin for the on-chip emulator enable signal. If the on-chip emulator is used, the signal level should be fixed high. If the on-chip emulator is not used, the signal level should be fixed low.
On-chip emulator	\overline{TRST}	Input	On-chip emulator pins or boundary scan pins. When the EMLE pin is driven high, these pins are dedicated for the on-chip emulator. When the EMLE pin is driven low and to mode 3, these pins are dedicated for the boundary scan.
	TMS	Input	
	TDI	Input	
	TCK	Input	
	TDO	Output	
Address bus	A23 to A0	Output	Output pins for the address bits.
Data bus	D15 to D0	Input/output	Input and output for the bidirectional data bus. These pins also output addresses when accessing an address–data multiplexed I/O interface space.
Bus control	\overline{BREQ}	Input	External bus-master modules assert this signal to request the bus.
	\overline{BREQO}	Output	Internal bus-master modules assert this signal to request access to the external space via the bus in the external bus released state.

Classification	Pin Name	I/O	Description
Bus control	BACK	Output	Bus acknowledge signal, which indicates that the bus has been released.
	$\overline{BS-A/BS-B}$	Output	Indicates the start of a bus cycle.
	\overline{AS}	Output	Strobe signal which indicates that the output address on the address bus is valid in access to the basic bus interface or byte control SRAM interface space.
	\overline{AH}	Output	This signal is used to hold the address when accessing the address-data multiplexed I/O interface space.
	\overline{RD}	Output	Strobe signal which indicates that reading from the basic bus interface space is in progress.
	$\overline{RD/WR}$	Output	Indicates the direction (input or output) of the data bus.
	\overline{LHWR}	Output	Strobe signal which indicates that the higher-order byte (D15 to D8) is valid in access to the basic bus interface space.
	\overline{LLWR}	Output	Strobe signal which indicates that the lower-order byte (D7 to D0) is valid in access to the basic bus interface space.
	\overline{LUB}	Output	Strobe signal which indicates that the higher-order byte (D15 to D8) is valid in access to the byte control SRAM interface space.
	\overline{LLB}	Output	Strobe signal which indicates that the lower-order byte (D7 to D0) is valid in access to the byte control SRAM interface space.
	$\overline{CS0}$ $\overline{CS1}$ $\overline{CS2-A/CS2-B}$ $\overline{CS3}$ $\overline{CS4-A/CS4-C}$ $\overline{CS5-A/CS5-B/}$ $\overline{CS5-C/CS5-D}$ $\overline{CS6-A/CS6-B/}$ $\overline{CS6-C/CS6-D}$ $\overline{CS7-A/CS7-B/}$ $\overline{CS7-C}$	Output	Select signals for areas 0 to 7.
	\overline{WAIT}	Input	Requests wait cycles in access to the external space.

Classification	Pin Name	I/O	Description
Interrupt	NMI	Input	Non-maskable interrupt request signal. When this pin is not in use, this signal must be fixed high.
	$\overline{\text{IRQ15}}$	Input	Maskable interrupt request signal.
	$\overline{\text{IRQ14}}$		
	$\overline{\text{IRQ13-A}}/\overline{\text{IRQ13-B}}$		
	$\overline{\text{IRQ12-A}}/\overline{\text{IRQ12-B}}$		
	$\overline{\text{IRQ11-A}}/\overline{\text{IRQ11-B}}$		
	$\overline{\text{IRQ10-A}}/\overline{\text{IRQ10-B}}$		
	$\overline{\text{IRQ9-A}}/\overline{\text{IRQ9-B}}$		
	$\overline{\text{IRQ8-A}}/\overline{\text{IRQ8-B}}$		
	$\overline{\text{IRQ7-A}}/\overline{\text{IRQ7-B}}$		
	$\overline{\text{IRQ6-A}}/\overline{\text{IRQ6-B}}$		
	$\overline{\text{IRQ5-A}}/\overline{\text{IRQ5-B}}$		
	$\overline{\text{IRQ4-A}}/\overline{\text{IRQ4-B}}$		
	$\overline{\text{IRQ3-A}}/\overline{\text{IRQ3-B}}$		
	$\overline{\text{IRQ2-A}}/\overline{\text{IRQ2-B}}$		
$\overline{\text{IRQ1-A}}/\overline{\text{IRQ1-B}}$			
$\overline{\text{IRQ0-A}}/\overline{\text{IRQ0-B}}$			
DMA controller (DMAC)	$\overline{\text{DREQ0-A}}/\overline{\text{DREQ0-B}}$	Input	Requests DMAC activation.
	$\overline{\text{DREQ1-A}}/\overline{\text{DREQ1-B}}$		
	DREQ2		
	DREQ3		
	$\overline{\text{DACK0-A}}/\overline{\text{DACK0-B}}$	Output	DMAC single address-transfer acknowledge signal.
	$\overline{\text{DACK1-A}}/\overline{\text{DACK1-B}}$		
	DACK2		
	DACK3		
	$\overline{\text{TEND0-A}}/\overline{\text{TEND0-B}}$	Output	Indicates end of data transfer by the DMAC.
$\overline{\text{TEND1-A}}/\overline{\text{TEND1-B}}$			
TEND2			
TEND3			
16-bit timer pulse unit (TPU)	TCLKA-A/TCLKA-B	Input	Input pins for the external clock signals.
	TCLKB-A/TCLKB-B		
	TCLKC-A/TCLKC-B		
	TCLKD-A/TCLKD-B		
	TIOCA0	Input/	Signals for TGRA_0 to TGRD_0. These pins are used as input capture inputs, output compare outputs, or PWM outputs.
	TIOCB0	output	
	TIOCC0		
TIOCD0			
TIOCA1	Input/	Signals for TGRA_1 and TGRB_1. These pins are used as input capture inputs, output compare outputs, or PWM outputs.	
TIOCB1	output		

Classification	Pin Name	I/O	Description
16-bit timer pulse unit (TPU)	TIOCA2	Input/ output	Signals for TGRA_2 and TGRB_2. These pins are used as input capture inputs, output compare outputs, or PWM outputs.
	TIOCB2		
	TIOCA3	Input/ output	Signals for TGRA_3 to TGRD_3. These pins are used as input capture inputs, output compare outputs, or PWM outputs.
	TIOCB3		
	TIOCC3		
	TIOCD3		
	TIOCA4	Input/ output	Signals for TGRA_4 and TGRB_4. These pins are used as input capture inputs, output compare outputs, or PWM outputs.
	TIOCB4		
	TIOCA5	Input/ output	Signals for TGRA_5 and TGRB_5. These pins are used as input capture inputs, output compare outputs, or PWM outputs.
	TIOCB5		
	TCLKE	Input	Input pins for external clock signals.
	TCLKF		
	TCLKG		
	TCLKH		
	TIOCA6	Input/ output	Signals for TGRA_6 to TGRD_6. These pins are used as input capture inputs, output compare outputs, or PWM outputs.
	TIOCB6		
	TIOCC6		
	TIOCD6		
	TIOCA7	Input/ output	Signals for TGRA_7 and TGRB_7. These pins are used as input capture inputs, output compare outputs, or PWM outputs.
	TIOCB7		
	TIOCA8	Input/ output	Signals for TGRA_8 and TGRB_8. These pins are used as input capture inputs, output compare outputs, or PWM outputs.
	TIOCB8		
	TIOCA9	Input/ output	Signals for TGRA_9 to TGRD_9. These pins are used as input capture inputs, output compare outputs, or PWM outputs.
	TIOCB9		
	TIOCC9		
	TIOCD9		
	TIOCA10	Input/ output	Signals for TGRA_10 and TGRB_10. These pins are used as input capture inputs, output compare outputs, or PWM outputs.
	TIOCB10		
	TIOCA11	Input/ output	Signals for TGRA_11 and TGRB_11. These pins are used as input capture inputs, output compare outputs, or PWM outputs.
	TIOCB11		
Programmable pulse generator (PPG)	PO31 to PO0	Output	Output pins for the pulse signals.

Classification	Pin Name	I/O	Description
8-bit timer (TMR)	TMO0 to TMO3	Output	Output pins for the compare match signals.
	TMCIO to TMCI3	Input	Input pins for the external clock signals that drive for the counters.
	TMRI0 to TMRI3	Input	Input pins for the counter-reset signals.
Watchdog timer (WDT)	$\overline{\text{WDTOVF}}$	Output	Output pin for the counter-overflow signal in watchdog-timer mode.
Serial communications interface (SCI)	TxD0	Output	Output pins for data transmission.
	TxD1		
	TxD2		
	TxD3		
	TxD4		
	TxD5		
	TxD6		
	RxD0	Input	Input pins for data reception.
	RxD1		
	RxD2		
	RxD3		
	RxD4		
	RxD5		
	RxD6		
	SCK0	Input/ output	Input/output pins for clock signals.
	SCK1		
	SCK2		
	SCK3		
SCK4			
SCK5			
SCK6			
SCI with IrDA (SCI)	IrTxD	Output	Output pin that outputs encoded data for IrDA.
	IrRxD	Input	Input pin that inputs encoded data for IrDA.
I2C bus interface 2 (IIC2)	SCL0, SCL1	Input/ output	Input/output pin for IIC clock. Bus can be directly driven by the NMOS open drain output.
	SDA0, SDA1	Input/ output	Input/output pin for IIC data. Bus can be directly driven by the NMOS open drain output.

Classification	Pin Name	I/O	Description
A/D converter	AN7 to AN0	Input	Input pins for the analog signals to be processed by the A/D converter.
	ADTRG0, ADTRG1	Input	Input pins for the external trigger signal that starts A/D conversion.
D/A converter	DA1, DA0	Output	Output pins for the analog signals from the D/A converter.
A/D converter, D/A converter	AV _{cc}	Input	Analog power supply pin for the A/D and D/A converters. When the A/D and D/A converters are not in use, connect this pin to the system power supply.
	AV _{ss}	Input	Ground pin for the A/D and D/A converters. Connect this pin to the system power supply (0 V).
	Vref	Input	Reference power supply pin for the A/D and D/A converters. When the A/D and D/A converters are not in use, connect this pin to the system power supply.
I/O ports	P17 to P10	Input/ output	8-bit input/output pins.
	P27 to P20	Input/ output	8-bit input/output pins.
	P37 to P30	Input/ output	8-bit input/output pins.
	P57 to P50	Input	8-bit input/output pins.
	P65 to P60	Input/ output	6-bit input/output pins.
	PA7	Input	Input-only pin
	PA6 to PA0	Input/ output	7-bit input/output pins.
	PB3 to PB0	Input/ output	4-bit input/output pins.
	PD7 to PD0	Input/ output	8-bit input/output pins.
	PE7 to PE0	Input/ output	8-bit input/output pins.
PF7 to PF0	Input/ output	8-bit input/output pins.	

Classification	Pin Name	I/O	Description
I/O ports	PH7 to PH0	Input/ output	8-bit input/output pins.
	PI7 to PI0	Input/ output	8-bit input/output pins.
	PJ7 to PJ0*	Input/ output	8-bit input/output pins.
	PK7 to PK0*	Input/ output	8-bit input/output pins.

Note: * These pins can be used when the PCJKE bit in PFCRD is set to 1 in single-chip mode.

Section 2 CPU

The H8SX CPU is a high-speed CPU with an internal 32-bit architecture that is upward compatible with the H8/300, H8/300H, and H8S CPUs.

The H8SX CPU has sixteen 16-bit general registers, can handle a 4-Gbyte linear address space, and is ideal for a realtime control system.

2.1 Features

- Upward-compatible with H8/300, H8/300H, and H8S CPUs
 - Can execute object programs of these CPUs
- Sixteen 16-bit general registers
 - Also usable as sixteen 8-bit registers or eight 32-bit registers
- 87 basic instructions
 - 8/16/32-bit arithmetic and logic instructions
 - Multiply and divide instructions
 - Bit field transfer instructions
 - Powerful bit-manipulation instructions
 - Bit condition branch instructions
 - Multiply-and-accumulate instruction
- Eleven addressing modes
 - Register direct [Rn]
 - Register indirect [@ERn]
 - Register indirect with displacement [@(d:2,ERn), @(d:16,ERn), or @(d:32,ERn)]
 - Index register indirect with displacement [@(d:16,RnL.B), @(d:32,RnL.B), @(d:16,Rn.W), @(d:32,Rn.W), @(d:16,ERn.L), or @(d:32,ERn.L)]
 - Register indirect with pre-/post-increment or pre-/post-decrement [@+ERn, @-ERn, @ERn+, or @ERn-]
 - Absolute address [@aa:8, @aa:16, @aa:24, or @aa:32]
 - Immediate [#xx:3, #xx:4, #xx:8, #xx:16, or #xx:32]
 - Program-counter relative [@(d:8,PC) or @(d:16,PC)]
 - Program-counter relative with index register [@(RnL.B,PC), @(Rn.W,PC), or @(ERn.L,PC)]
 - Memory indirect [@@aa:8]
 - Extended memory indirect [@@vec:7]

- Two base registers
 - Vector base register
 - Short address base register
- 4-Gbyte address space
 - Program: 4 Gbytes
 - Data: 4 Gbytes
- High-speed operation
 - All frequently-used instructions executed in one or two states
 - 8/16/32-bit register-register add/subtract: 1 state
 - 8×8 -bit register-register multiply: 1 state
 - $16 \div 8$ -bit register-register divide: 10 states
 - 16×16 -bit register-register multiply: 1 state
 - $32 \div 16$ -bit register-register divide: 18 states
 - 32×32 -bit register-register multiply: 5 states
 - $32 \div 32$ -bit register-register divide: 18 states
- Four CPU operating modes
 - Normal mode
 - Middle mode
 - Advanced mode
 - Maximum mode
- Power-down modes
 - Transition is made by execution of SLEEP instruction
 - Choice of CPU operating clocks

- Notes:
1. Advanced mode is only supported as the CPU operating mode of the H8SX/1638 Group and the H8SX/1638L Group. Normal, middle, and maximum modes are not supported.
 2. The multiplier and divider are supported by the H8SX/1638 Group and the H8SX/1638L Group.

2.2 CPU Operating Modes

The H8SX CPU has four operating modes: normal, middle, advanced and maximum modes. These modes can be selected by the mode pins of this LSI.

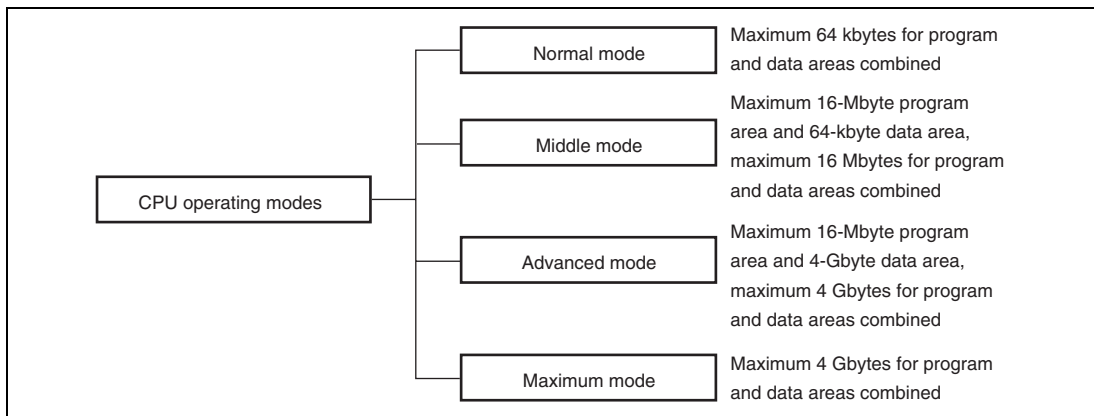

Figure 2.1 CPU Operating Modes

2.2.1 Normal Mode

The exception vector table and stack have the same structure as in the H8/300 CPU.

- Address Space

The maximum address space of 64 kbytes can be accessed.

- Extended Registers (En)

The extended registers (E0 to E7) can be used as 16-bit registers, or as the upper 16-bit segments of 32-bit registers. When the extended register En is used as a 16-bit register it can contain any value, even when the corresponding general register Rn is used as an address register. (If the general register Rn is referenced in the register indirect addressing mode with pre-/post-increment or pre-/post-decrement and a carry or borrow occurs, however, the value in the corresponding extended register En will be affected.)

- Instruction Set

All instructions and addressing modes can be used. Only the lower 16 bits of effective addresses (EA) are valid.

- Exception Vector Table and Memory Indirect Branch Addresses

In normal mode, the top area starting at H'0000 is allocated to the exception vector table. One branch address is stored per 16 bits. The structure of the exception vector table is shown in figure 2.2.

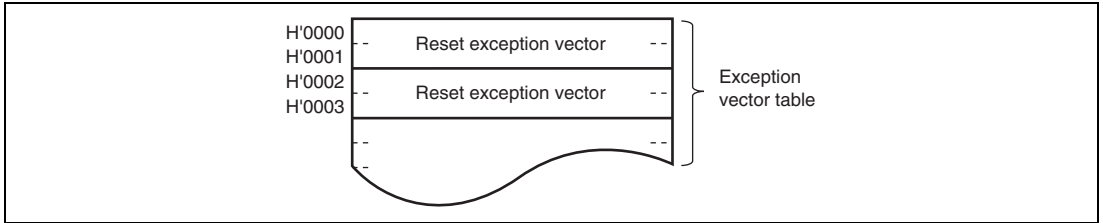

Figure 2.2 Exception Vector Table (Normal Mode)

The memory indirect (@@aa:8) and extended memory indirect (@@vec:7) addressing modes are used in the JMP and JSR instructions. An 8-bit absolute address included in the instruction code specifies a memory location. Execution branches to the contents of the memory location.

- Stack Structure

The stack structure of PC at a subroutine branch and that of PC and CCR at an exception handling are shown in figure 2.3. The PC contents are saved or restored in 16-bit units.

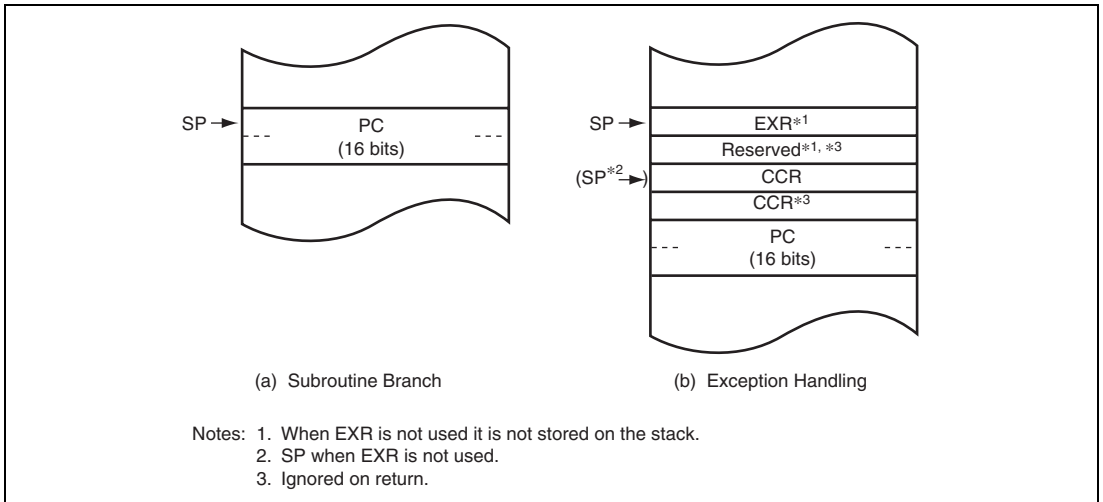

Figure 2.3 Stack Structure (Normal Mode)

2.2.2 Middle Mode

The program area in middle mode is extended to 16 Mbytes as compared with that in normal mode.

- Address Space

The maximum address space of 16 Mbytes can be accessed as a total of the program and data areas. For individual areas, up to 16 Mbytes of the program area or up to 64 kbytes of the data area can be allocated.

- Extended Registers (En)

The extended registers (E0 to E7) can be used as 16-bit registers, or as the upper 16-bit segments of 32-bit registers. When the extended register En is used as a 16-bit register (in other than the JMP and JSR instructions), it can contain any value even when the corresponding general register Rn is used as an address register. (If the general register Rn is referenced in the register indirect addressing mode with pre-/post-increment or pre-/post-decrement and a carry or borrow occurs, however, the value in the corresponding extended register En will be affected.)

- Instruction Set

All instructions and addressing modes can be used. Only the lower 16 bits of effective addresses (EA) are valid and the upper eight bits are sign-extended.

- Exception Vector Table and Memory Indirect Branch Addresses

In middle mode, the top area starting at H'000000 is allocated to the exception vector table. One branch address is stored per 32 bits. The upper eight bits are ignored and the lower 24 bits are stored. The structure of the exception vector table is shown in figure 2.4.

The memory indirect (@@aa:8) and extended memory indirect (@@vec:7) addressing modes are used in the JMP and JSR instructions. An 8-bit absolute address included in the instruction code specifies a memory location. Execution branches to the contents of the memory location.

In middle mode, an operand is a 32-bit (longword) operand, providing a 32-bit branch address. The upper eight bits are reserved and assumed to be H'00.

- Stack Structure

The stack structure of PC at a subroutine branch and that of PC and CCR at an exception handling are shown in figure 2.5. The PC contents are saved or restored in 24-bit units.

2.2.3 Advanced Mode

The data area is extended to 4 Gbytes as compared with that in middle mode.

- Address Space

The maximum address space of 4 Gbytes can be linearly accessed. For individual areas, up to 16 Mbytes of the program area and up to 4 Gbytes of the data area can be allocated.

- Extended Registers (En)

The extended registers (E0 to E7) can be used as 16-bit registers, or as the upper 16-bit segments of 32-bit registers or address registers.

- Instruction Set

All instructions and addressing modes can be used.

- Exception Vector Table and Memory Indirect Branch Addresses

In advanced mode, the top area starting at H'00000000 is allocated to the exception vector table. One branch address is stored per 32 bits. The upper eight bits are ignored and the lower 24 bits are stored. The structure of the exception vector table is shown in figure 2.4.

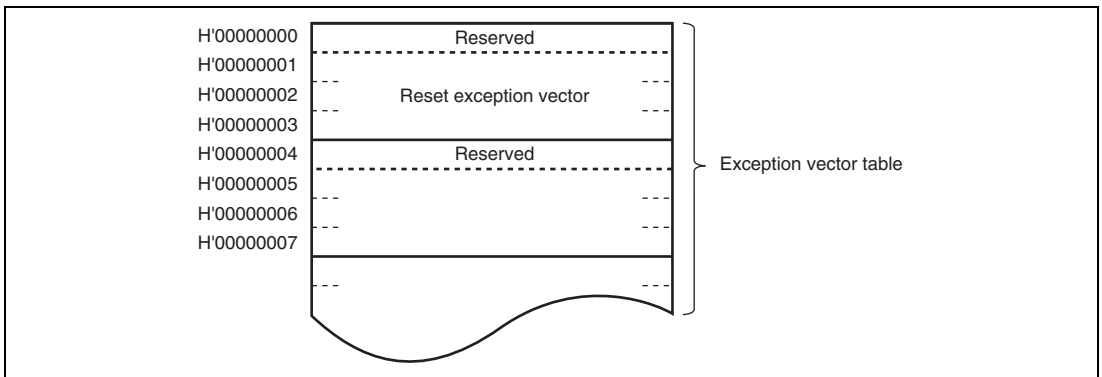

Figure 2.4 Exception Vector Table (Middle and Advanced Modes)

The memory indirect (@@aa:8) and extended memory indirect (@@vec:7) addressing modes are used in the JMP and JSR instructions. An 8-bit absolute address included in the instruction code specifies a memory location. Execution branches to the contents of the memory location. In advanced mode, an operand is a 32-bit (longword) operand, providing a 32-bit branch address. The upper eight bits are reserved and assumed to be H'00.

- Stack Structure

The stack structure of PC at a subroutine branch and that of PC and CCR at an exception handling are shown in figure 2.5. The PC contents are saved or restored in 24-bit units.

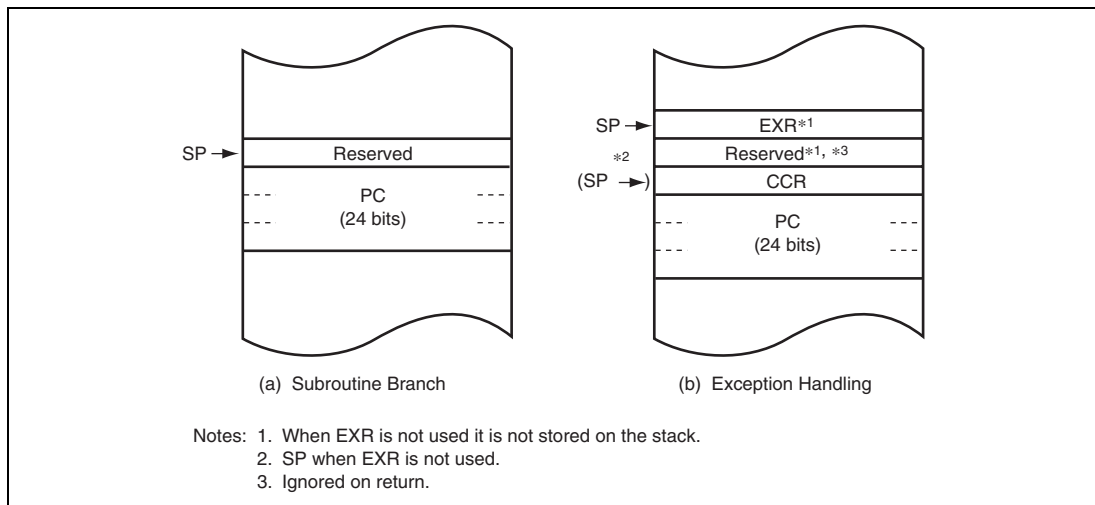

Figure 2.5 Stack Structure (Middle and Advanced Modes)

2.2.4 Maximum Mode

The program area is extended to 4 Gbytes as compared with that in advanced mode.

- Address Space

The maximum address space of 4 Gbytes can be linearly accessed.

- Extended Registers (En)

The extended registers (E0 to E7) can be used as 16-bit registers or as the upper 16-bit segments of 32-bit registers or address registers.

- Instruction Set

All instructions and addressing modes can be used.

- Exception Vector Table and Memory Indirect Branch Addresses

In maximum mode, the top area starting at H'00000000 is allocated to the exception vector table. One branch address is stored per 32 bits. The structure of the exception vector table is shown in figure 2.6.

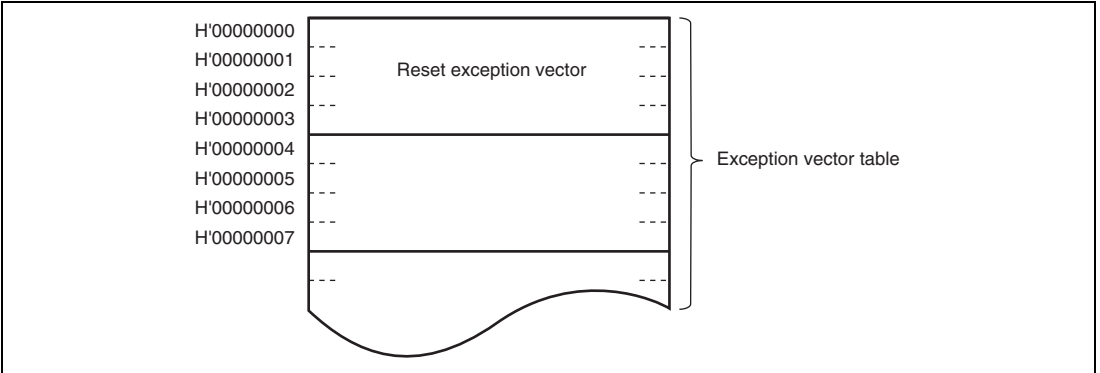

Figure 2.6 Exception Vector Table (Maximum Modes)

The memory indirect (@@aa:8) and extended memory indirect (@@vec:7) addressing modes are used in the JMP and JSR instructions. An 8-bit absolute address included in the instruction code specifies a memory location. Execution branches to the contents of the memory location. In maximum mode, an operand is a 32-bit (longword) operand, providing a 32-bit branch address.

- Stack Structure

The stack structure of PC at a subroutine branch and that of PC and CCR at an exception handling are shown in figure 2.7. The PC contents are saved or restored in 32-bit units. The EXR contents are saved or restored regardless of whether or not EXR is in use.

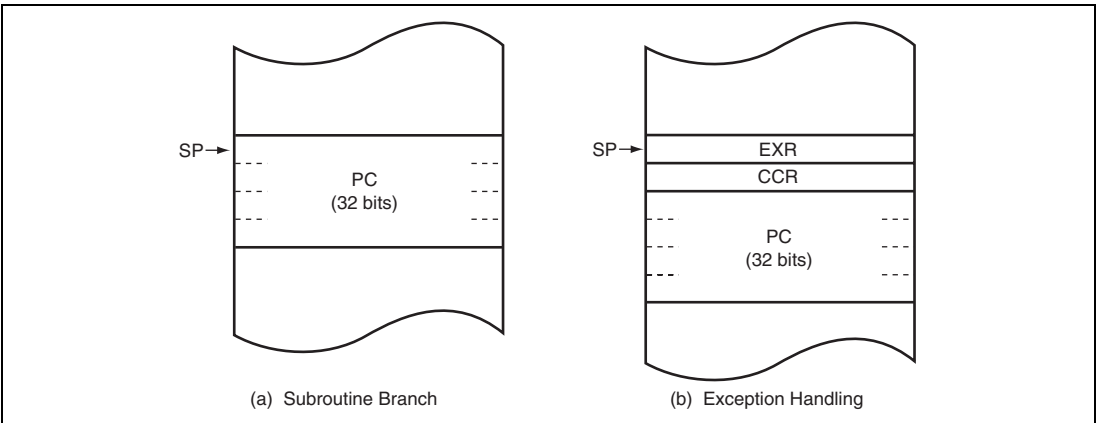

Figure 2.7 Stack Structure (Maximum Mode)

2.3 Instruction Fetch

The H8SX CPU has two modes for instruction fetch: 16-bit and 32-bit modes. It is recommended that the mode be set according to the bus width of the memory in which a program is stored. The instruction-fetch mode setting does not affect operation other than instruction fetch such as data accesses. Whether an instruction is fetched in 16- or 32-bit mode is selected by the FETCHMD bit in SYSCR. For details, see section 3.2.2, System Control Register (SYSCR).

2.4 Address Space

Figure 2.8 shows a memory map of the H8SX CPU. The address space differs depending on the CPU operating mode.

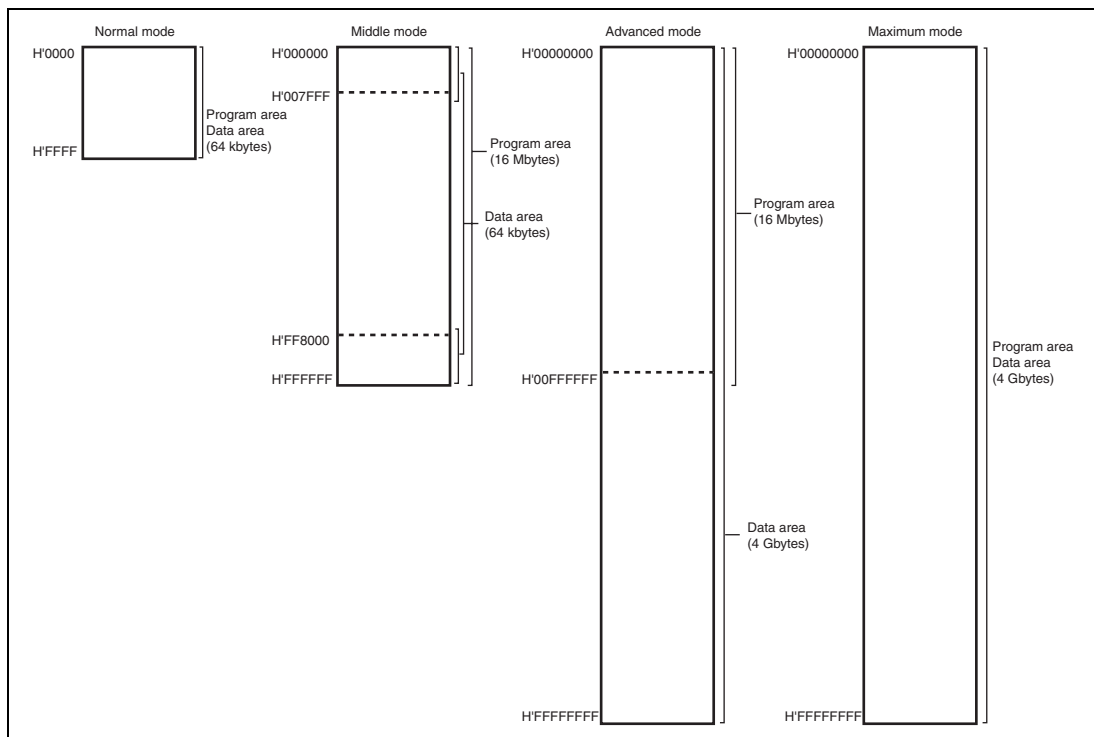

Figure 2.8 Memory Map

2.5 Registers

The H8SX CPU has the internal registers shown in figure 2.9. There are two types of registers: general registers and control registers. The control registers are the 32-bit program counter (PC), 8-bit extended control register (EXR), 8-bit condition-code register (CCR), 32-bit vector base register (VBR), 32-bit short address base register (SBR), and 64-bit multiply-accumulate register (MAC).

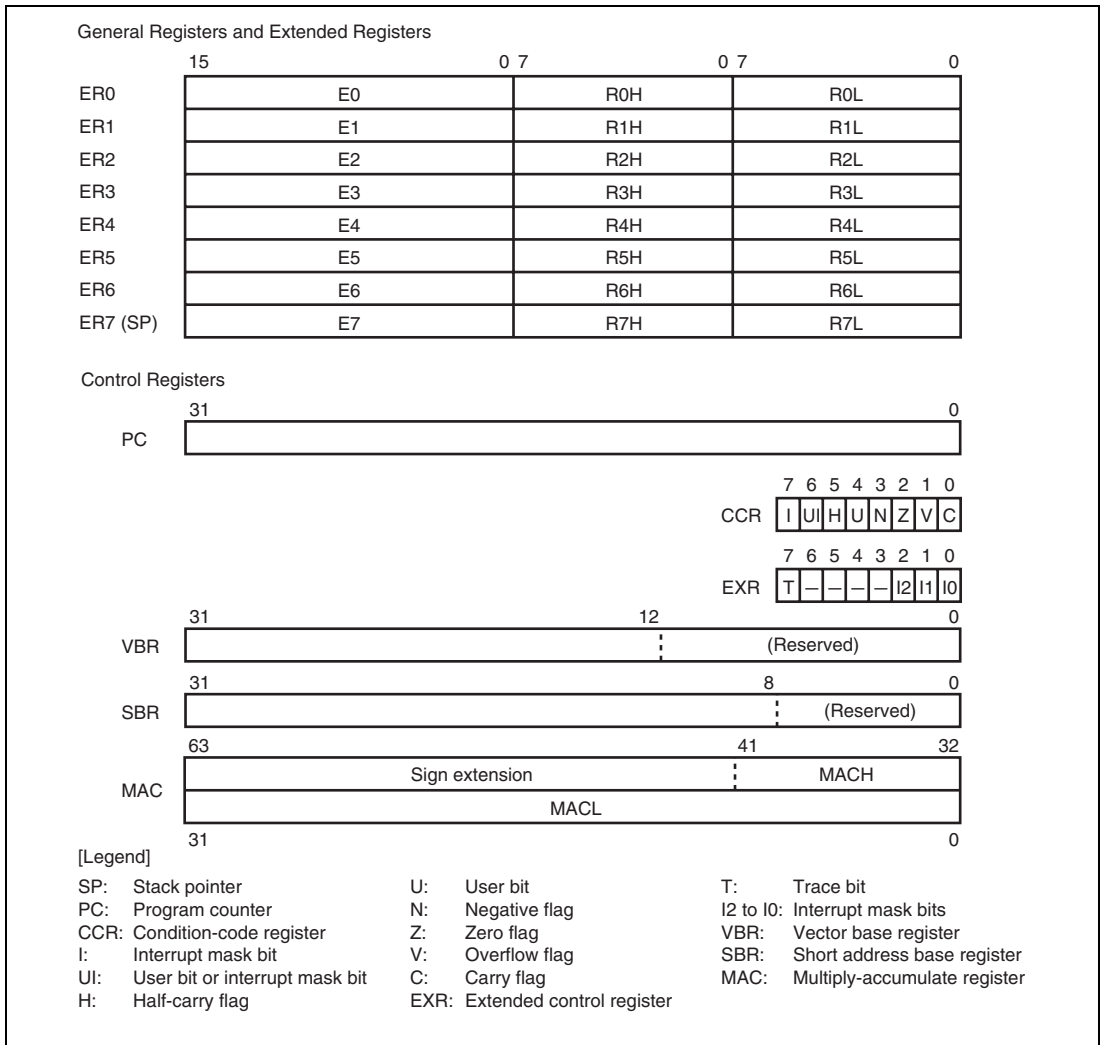

Figure 2.9 CPU Registers

2.5.1 General Registers

The H8SX CPU has eight 32-bit general registers. These general registers are all functionally alike and can be used as both address registers and data registers. When a general register is used as a data register, it can be accessed as a 32-bit, 16-bit, or 8-bit register. Figure 2.10 illustrates the usage of the general registers.

When the general registers are used as 32-bit registers or address registers, they are designated by the letters ER (ER0 to ER7).

When the general registers are used as 16-bit registers, the ER registers are divided into 16-bit general registers designated by the letters E (E0 to E7) and R (R0 to R7). These registers are functionally equivalent, providing a maximum sixteen 16-bit registers. The E registers (E0 to E7) are also referred to as extended registers.

When the general registers are used as 8-bit registers, the R registers are divided into 8-bit general registers designated by the letters RH (R0H to R7H) and RL (R0L to R7L). These registers are functionally equivalent, providing a maximum sixteen 8-bit registers.

The general registers ER (ER0 to ER7), R (R0 to R7), and RL (R0L to R7L) are also used as index registers. The size in the operand field determines which register is selected.

The usage of each register can be selected independently.

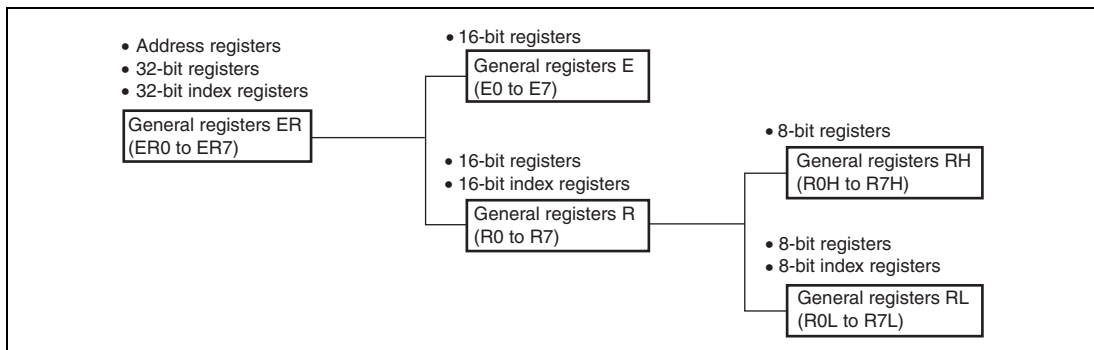

Figure 2.10 Usage of General Registers

General register ER7 has the function of stack pointer (SP) in addition to its general-register function, and is used implicitly in exception handling and subroutine branches. Figure 2.11 shows the stack.

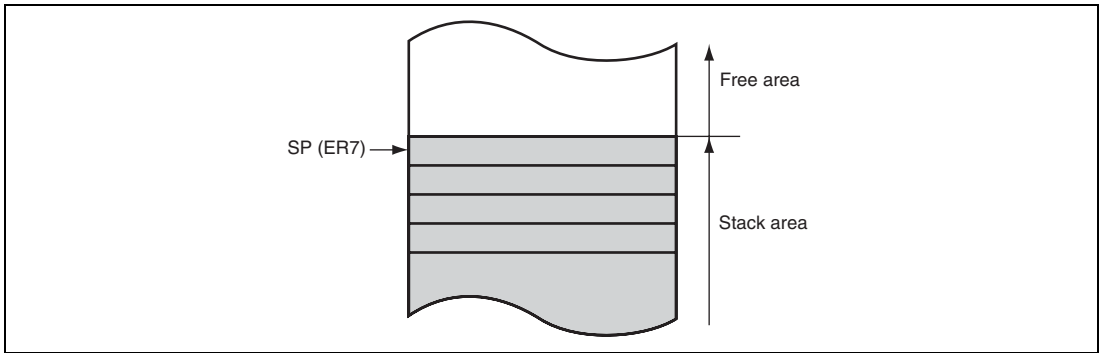

Figure 2.11 Stack

2.5.2 Program Counter (PC)

PC is a 32-bit counter that indicates the address of the next instruction the CPU will execute. The length of all CPU instructions is 16 bits (one word) or a multiple of 16 bits, so the least significant bit is ignored. (When the instruction code is fetched, the least significant bit is regarded as 0.)

2.5.3 Condition-Code Register (CCR)

CCR is an 8-bit register that contains internal CPU status information, including an interrupt mask (I) and user (UI, U) bits and half-carry (H), negative (N), zero (Z), overflow (V), and carry (C) flags.

Operations can be performed on the CCR bits by the LDC, STC, ANDC, ORC, and XORC instructions. The N, Z, V, and C flags are used as branch conditions for conditional branch (Bcc) instructions.

Bit	Bit Name	Initial Value	R/W	Description
7	I	1	R/W	Interrupt Mask Bit Masks interrupts when set to 1. This bit is set to 1 at the start of an exception handling.
6	UI	Undefined	R/W	User Bit Can be written to and read from by software using the LDC, STC, ANDC, ORC, and XORC instructions.
5	H	Undefined	R/W	Half-Carry Flag When the ADD.B, ADDX.B, SUB.B, SUBX.B, CMP.B, or NEG.B instruction is executed, this flag is set to 1 if there is a carry or borrow at bit 3, and cleared to 0 otherwise. When the ADD.W, SUB.W, CMP.W, or NEG.W instruction is executed, this flag is set to 1 if there is a carry or borrow at bit 11, and cleared to 0 otherwise. When the ADD.L, SUB.L, CMP.L, or NEG.L instruction is executed, this flag is set to 1 if there is a carry or borrow at bit 27, and cleared to 0 otherwise.
4	U	Undefined	R/W	User Bit Can be written to and read from by software using the LDC, STC, ANDC, ORC, and XORC instructions.
3	N	Undefined	R/W	Negative Flag Stores the value of the most significant bit (regarded as sign bit) of data.

Bit	Bit Name	Initial Value	R/W	Description
2	Z	Undefined	R/W	Zero Flag Set to 1 to indicate zero data, and cleared to 0 to indicate non-zero data.
1	V	Undefined	R/W	Overflow Flag Set to 1 when an arithmetic overflow occurs, and cleared to 0 otherwise.
0	C	Undefined	R/W	Carry Flag Set to 1 when a carry occurs, and cleared to 0 otherwise. A carry has the following types: <ul style="list-style-type: none"> • Carry from the result of addition • Borrow from the result of subtraction • Carry from the result of shift or rotation The carry flag is also used as a bit accumulator by bit manipulation instructions.

2.5.4 Extended Control Register (EXR)

EXR is an 8-bit register that contains the trace bit (T) and three interrupt mask bits (I2 to I0).

Operations can be performed on the EXR bits by the LDC, STC, ANDC, ORC, and XORC instructions.

For details, see section 6, Exception Handling.

Bit	Bit Name	Initial Value	R/W	Description
7	T	0	R/W	Trace Bit When this bit is set to 1, a trace exception is generated each time an instruction is executed. When this bit is cleared to 0, instructions are executed in sequence.
6 to 3	—	All 1	R/W	Reserved These bits are always read as 1.
2	I2	1	R/W	Interrupt Mask Bits
1	I1	1	R/W	These bits designate the interrupt mask level (0 to 7).
0	I0	1	R/W	

2.5.5 Vector Base Register (VBR)

VBR is a 32-bit register in which the upper 20 bits are valid. The lower 12 bits of this register are read as 0s. This register is a base address of the vector area for exception handlings other than a reset and a CPU address error (extended memory indirect is also out of the target). The initial value is H'00000000. The VBR contents are changed with the LDC and STC instructions.

2.5.6 Short Address Base Register (SBR)

SBR is a 32-bit register in which the upper 24 bits are valid. The lower eight bits are read as 0s. In 8-bit absolute address addressing mode (@aa:8), this register is used as the upper address. The initial value is H'FFFFFF00. The SBR contents are changed with the LDC and STC instructions.

2.5.7 Multiply-Accumulate Register (MAC)

MAC is a 64-bit register that stores the results of multiply-and-accumulate operations. It consists of two 32-bit registers denoted MACH and MACL. The lower 10 bits of MACH are valid; the upper bits are sign extended. The MAC contents are changed with the MAC, CLRMAC, LDMAC, and STMAC instructions.

2.5.8 Initial Values of CPU Registers

Reset exception handling loads the start address from the vector table into the PC, clears the T bit in EXR to 0, and sets the I bits in CCR and EXR to 1. The general registers, MAC, and the other bits in CCR are not initialized. In particular, the initial value of the stack pointer (ER7) is undefined. The SP should therefore be initialized using an MOV.L instruction executed immediately after a reset.

2.6 Data Formats

The H8SX CPU can process 1-bit, 4-bit BCD, 8-bit (byte), 16-bit (word), and 32-bit (longword) data.

Bit-manipulation instructions operate on 1-bit data by accessing bit n ($n = 0, 1, 2, \dots, 7$) of byte operand data. The DAA and DAS decimal-adjust instructions treat byte data as two digits of 4-bit BCD data.

2.6.1 General Register Data Formats

Figure 2.12 shows the data formats in general registers.

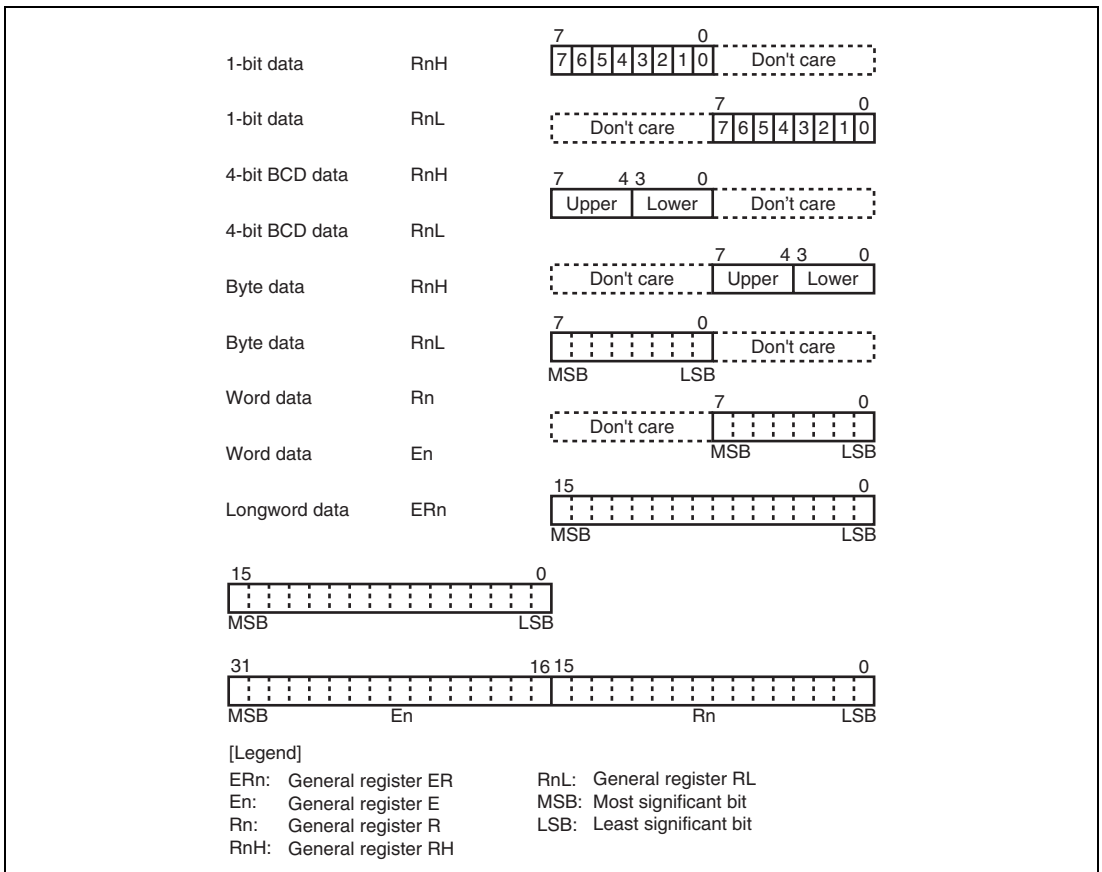

Figure 2.12 General Register Data Formats

2.6.2 Memory Data Formats

Figure 2.13 shows the data formats in memory.

The H8SX CPU can access word data and longword data which are stored at any addresses in memory. When word data begins at an odd address or longword data begins at an address other than a multiple of 4, a bus cycle is divided into two or more accesses. For example, when longword data begins at an odd address, the bus cycle is divided into byte, word, and byte accesses. In this case, these accesses are assumed to be individual bus cycles.

However, instructions to be fetched, word and longword data to be accessed during execution of the stack manipulation, branch table manipulation, block transfer instructions, and MAC instruction should be located to even addresses.

When SP (ER7) is used as an address register to access the stack, the operand size should be word size or longword size.

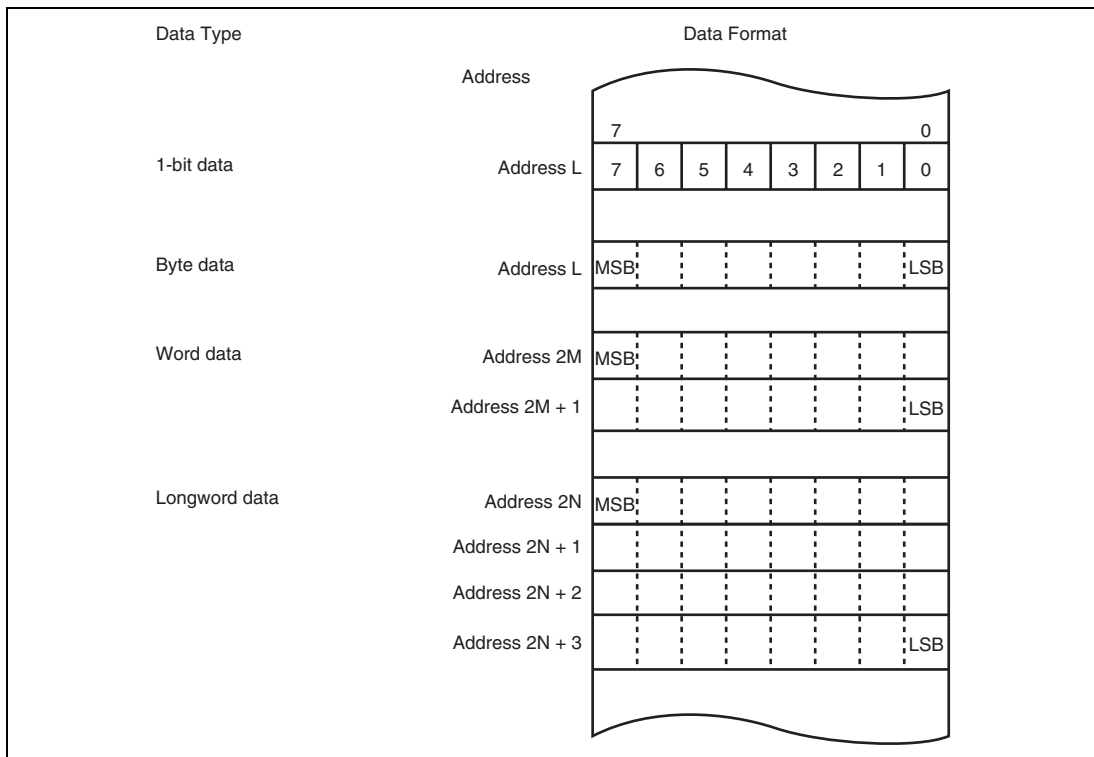

Figure 2.13 Memory Data Formats

2.7 Instruction Set

The H8SX CPU has 87 types of instructions. The instructions are classified by function as shown in table 2.1. The arithmetic operation, logic operation, shift, and bit manipulation instructions are called operation instruction in this manual.

Table 2.1 Instruction Classification

Function	Instructions	Size	Types
Data transfer	MOV	B/W/L	6
	MOVFPE, MOVTPPE	B	
	POP, PUSH* ¹	W/L	
	LDM, STM	L	
	MOVA	B/W* ²	
Block transfer	EPMOV	B	3
	MOVMD	B/W/L	
	MOVSD	B	
Arithmetic operations	ADD, ADDX, SUB, SUBX, CMP, NEG, INC, DEC	B/W/L	27
	DAA, DAS	B	
	ADDS, SUBS	L	
	MULXU, DIVXU, MULXS, DIVXS	B/W	
	MULU, DIVU, MULS, DIVS	W/L	
	MULU/U* ⁶ , MULS/U* ⁶	L	
	EXTU, EXTS	W/L	
	TAS	B	
	MAC* ⁶	—	
	LDMAC* ⁶ , STMAC* ⁶	—	
	CLRMAC* ⁶	—	
Logic operations	AND, OR, XOR, NOT	B/W/L	4
Shift	SHLL, SHLR, SHAL, SHAR, ROTL, ROTR, ROTXL, ROTXR	B/W/L	8
Bit manipulation	BSET, BCLR, BNOT, BTST, BAND, BIAND, BOR, BIOR, BXOR, BIXOR, BLD, BILD, BST, BIST	B	20
	BSET/EQ, BSET/NE, BCLR/EQ, BCLR/NE, BSTZ, BISTZ	B	
	BFLD, BFST	B	

Function	Instructions	Size	Types
Branch	BRA/BS, BRA/BC, BSR/BS, BSR/BC	B* ³	9
	Bcc* ⁴ , JMP, BSR, JSR, RTS	—	
	RTS/L	L* ⁵	
	BRA/S	—	
System control	TRAPA, RTE, SLEEP, NOP	—	10
	RTE/L	L* ⁵	
	LDC, STC, ANDC, ORC, XORC	B/W/L	
		Total	87

[Legend]

B: Byte size

W: Word size

L: Longword size

- Notes: 1. POP.W Rn and PUSH.W Rn are identical to MOV.W @SP+, Rn and MOV.W Rn, @-SP.
 POP.L ERn and PUSH.L ERn are identical to MOV.L @SP+, ERn and MOV.L ERn, @-SP.
2. Size of data to be added with a displacement
 3. Size of data to specify a branch condition
 4. Bcc is the generic designation of a conditional branch instruction.
 5. Size of general register to be restored
 6. Not available in this LSI.

2.7.1 Instructions and Addressing Modes

Table 2.2 indicates the combinations of instructions and addressing modes that the H8SX CPU can use.

Table 2.2 Combinations of Instructions and Addressing Modes (1)

Classification	Instruction	Size	#xx	Rn	Addressing Mode						
					@ERn	@(d,ERn)	Rn.L.B/ Rn.W/ ERn.L)	@-ERn/ @Ern+/ @Ern-/ @+ERn	@aa:16/ @aa:32	—	
Data transfer	MOV	B/W/L	S	SD	SD	SD	SD	SD	SD	SD	
		B		S/D					S/D		
	MOVFP, MOVTP	B		S/D						S/D* ¹	
	POP, PUSH	W/L		S/D				S/D* ²			
	LDM, STM	L		S/D				S/D* ²			
	MOVA* ⁴	B/W		S	S	S	S	S	S	S	
Block transfer	EEPMOV	B									SD* ³
	MOVMD	B/W/L									SD* ³
	MOVSD	B									SD* ³
Arithmetic operations	ADD, CMP	B	S	D	D	D	D	D	D	D	
		B		S	D	D	D	D	D	D	
		B		D	S	S	S	S	S	S	
		B			SD	SD	SD	SD			SD
		W/L	S	SD	SD	SD	SD	SD			SD
	SUB	B	S		D	D	D	D	D	D	
		B		S	D	D	D	D	D	D	
		B		D	S	S	S	S	S	S	
		B			SD	SD	SD	SD			SD
		W/L	S	SD	SD	SD	SD	SD			SD
	ADDX, SUBX	B/W/L	S		SD						
		B/W/L	S		SD						
		B/W/L	S					SD* ⁵			
	INC, DEC	B/W/L		D							
	ADDS, SUBS	L		D							
	DAA, DAS	B		D							
	MULXU, DIVXU	B/W	S:4	SD							
	MULU, DIVU	W/L	S:4	SD							

Classification	Instruction	Size	#xx	Rn	Addressing Mode					
					@ERn	@(d,ERn)	Rn.L/B/ Rn.W/ ERn.L)	@-ERn/ @Ern+/ @Ern-/ @+ERn	@aa:16/ @aa:32	—
Arithmetic operations	MULXS, DIVXS	B/W	S:4	SD						
	MULS, DIVS	W/L	S:4	SD						
	NEG	B		D	D	D	D	D	D	D
		W/L		D	D	D	D	D	D	D
	EXTU, EXTS	W/L		D	D	D	D	D	D	
	TAS	B			D					
	MAC* ¹²	—								
	CLRMAC* ¹²	—								O
	LDMAC* ¹²	—		S						
STMAC* ¹²	—		D							
Logic operations	AND, OR, XOR	B		S	D	D	D	D	D	D
				D	S	S	S	S	S	S
				SD	SD	SD	SD	SD	SD	SD
		W/L	S	SD	SD	SD	SD	SD	SD	SD
	NOT	B		D	D	D	D	D	D	D
		W/L		D	D	D	D	D	D	D
Shift	SHLL, SHLR	B		D	D	D	D	D	D	D
		W/L* ⁶		D	D	D	D	D	D	D
		B/W/L* ⁷		D						
	SHAL, SHAR ROTL, ROTR ROTXL, ROTXR	B		D	D	D	D	D	D	D
		W/L		D	D	D	D	D	D	D
Bit manipulation	BSET, BCLR, BNOT, BTST, BSET/cc, BCLR/cc	B		D	D			D	D	
		BAND, BIAND, BOR, BIOR, BXOR, BIXOR, BLD, BILD, BST, BIST, BSTZ, BISTZ	B		D	D			D	D

Classification	Instruction	Size	#xx	Rn	@ERn	Addressing Mode					—
						@(d, RnL.B/ Rn.W/ ERn.L)	@-ERn/ @Ern+/ @Ern-/ @+ERn	@aa:16/ @aa:32			
Bit manipulation	BFLD	B		D	S				S	S	
	BFST	B		S	D				D	D	
Branch	BRA/BS, BRA/BC* ⁸	B			S				S	S	
	BSR/BS, BSR/BC* ⁸	B			S				S	S	
System control	LDC (CCR, EXR)	B/W* ⁹	S	S	S	S			S* ¹⁰	S	
	LDC (VBR, SBR)	L			S						
	STC (CCR, EXR)	B/W* ⁹		D	D	D			D* ¹¹	D	
	STC (VBR, SBR)	L			D						
	ANDC, ORC, XORC	B	S								
	SLEEP	—									
NOP	—										O

[Legend]

d: d:16 or d:32

S: Can be specified as a source operand.

D: Can be specified as a destination operand.

SD: Can be specified as either a source or destination operand or both.

S/D: Can be specified as either a source or destination operand.

S:4: 4-bit immediate data can be specified as a source operand.

Notes: 1. Only @aa:16 is available.

2. @ERn+ as a source operand and @-ERn as a destination operand

3. Specified by ER5 as a source address and ER6 as a destination address for data transfer.

4. Size of data to be added with a displacement

5. Only @ERn- is available

6. When the number of bits to be shifted is 1, 2, 4, 8, or 16

7. When the number of bits to be shifted is specified by 5-bit immediate data or a general register

8. Size of data to specify a branch condition

9. Byte when immediate or register direct, otherwise, word

10. Only @ERn+ is available

11. Only @-ERn is available

12. Not available in this LSI.

Table 2.2 Combinations of Instructions and Addressing Modes (2)

Classifi- cation	Instruction	Size	Addressing Mode						—	
			@ERn	@(d,PC)	@(RnL, B/Rn.W/ ERn.L, PC)	@aa:24	@aa:32	@@aa:8		@@vec:7
Branch	BRA/BS, BRA/BC	—		O						
	BSR/BS, BSR/BC	—		O						
	Bcc	—		O						
	BRA	—		O	O					
	BRA/S	—		O*						
	JMP	—	O			O	O	O	O	
	BSR	—		O						
	JSR	—	O			O	O	O	O	
	RTS, RTS/L	—								O
System control	TRAPA	—								O
	RTE, RTE/L	—								O

[Legend]

d: d:8 or d:16

Note: * Only @(d:8, PC) is available.

2.7.2 Table of Instructions Classified by Function

Tables 2.4 to 2.11 summarize the instructions in each functional category. The notation used in these tables is defined in table 2.3.

Table 2.3 Operation Notation

Operation Notation	Description
Rd	General register (destination)*
Rs	General register (source)*
Rn	General register*
ERn	General register (32-bit register)
(EAd)	Destination operand
(EAs)	Source operand
EXR	Extended control register
CCR	Condition-code register
VBR	Vector base register
SBR	Short address base register
N	N (negative) flag in CCR
Z	Z (zero) flag in CCR
V	V (overflow) flag in CCR
C	C (carry) flag in CCR
PC	Program counter
SP	Stack pointer
#IMM	Immediate data
disp	Displacement
+	Addition
-	Subtraction
×	Multiplication
÷	Division
^	Logical AND
∨	Logical OR
⊕	Logical exclusive OR
→	Move
~	Logical not (logical complement)
:8/:16/:24/:32	8-, 16-, 24-, or 32-bit length

Note: * General registers include 8-bit registers (R0H to R7H, R0L to R7L), 16-bit registers (R0 to R7, E0 to E7), and 32-bit registers (ER0 to ER7).

Table 2.4 Data Transfer Instructions

Instruction	Size	Function
MOV	B/W/L	#IMM → (EAd), (EAs) → (EAd) Transfers data between immediate data, general registers, and memory.
MOVFP	B	(EAs) → Rd
MOVTPE	B	Rs → (EAs)
POP	W/L	@SP+ → Rn Restores the data from the stack to a general register.
PUSH	W/L	Rn → @-SP Saves general register contents on the stack.
LDM	L	@SP+ → Rn (register list) Restores the data from the stack to multiple general registers. Two, three, or four general registers which have serial register numbers can be specified.
STM	L	Rn (register list) → @-SP Saves the contents of multiple general registers on the stack. Two, three, or four general registers which have serial register numbers can be specified.
MOVA	B/W	EA → Rd Zero-extends and shifts the contents of a specified general register or memory data and adds them with a displacement. The result is stored in a general register.

Table 2.5 Block Transfer Instructions

Instruction	Size	Function
EEPMOV.B EEPMOV.W	B	Transfers a data block. Transfers byte data which begins at a memory location specified by ER5 to a memory location specified by ER6. The number of byte data to be transferred is specified by R4 or R4L.
MOVMD.B	B	Transfers a data block. Transfers byte data which begins at a memory location specified by ER5 to a memory location specified by ER6. The number of byte data to be transferred is specified by R4.
MOVMD.W	W	Transfers a data block. Transfers word data which begins at a memory location specified by ER5 to a memory location specified by ER6. The number of word data to be transferred is specified by R4.
MOVMD.L	L	Transfers a data block. Transfers longword data which begins at a memory location specified by ER5 to a memory location specified by ER6. The number of longword data to be transferred is specified by R4.
MOVSD.B	B	Transfers a data block with zero data detection. Transfers byte data which begins at a memory location specified by ER5 to a memory location specified by ER6. The number of byte data to be transferred is specified by R4. When zero data is detected during transfer, the transfer stops and execution branches to a specified address.

Table 2.6 Arithmetic Operation Instructions

Instruction	Size	Function
ADD SUB	B/W/L	$(EAd) \pm \#IMM \rightarrow (EAd)$, $(EAd) \pm (EAs) \rightarrow (EAd)$ Performs addition or subtraction on data between immediate data, general registers, and memory. Immediate byte data cannot be subtracted from byte data in a general register.
ADDX SUBX	B/W/L	$(EAd) \pm \#IMM \pm C \rightarrow (EAd)$, $(EAd) \pm (EAs) \pm C \rightarrow (EAd)$ Performs addition or subtraction with carry on data between immediate data, general registers, and memory. The addressing mode which specifies a memory location can be specified as register indirect with post-decrement or register indirect.
INC DEC	B/W/L	$Rd \pm 1 \rightarrow Rd$, $Rd \pm 2 \rightarrow Rd$ Increments or decrements a general register by 1 or 2. (Byte operands can be incremented or decremented by 1 only.)
ADDS SUBS	L	$Rd \pm 1 \rightarrow Rd$, $Rd \pm 2 \rightarrow Rd$, $Rd \pm 4 \rightarrow Rd$ Adds or subtracts the value 1, 2, or 4 to or from data in a general register.
DAA DAS	B	Rd (decimal adjust) $\rightarrow Rd$ Decimal-adjusts an addition or subtraction result in a general register by referring to the CCR to produce 2-digit 4-bit BCD data.
MULXU	B/W	$Rd \times Rs \rightarrow Rd$ Performs unsigned multiplication on data in two general registers: either 8 bits \times 8 bits \rightarrow 16 bits, or 16 bits \times 16 bits \rightarrow 32 bits.
MULU	W/L	$Rd \times Rs \rightarrow Rd$ Performs unsigned multiplication on data in two general registers: either 8 bits \times 8 bits \rightarrow 16 bits, or 16 bits \times 16 bits \rightarrow 32 bits.
MULU/U*	L	$Rd \times Rs \rightarrow Rd$ Performs unsigned multiplication on data in two general registers (32 bits \times 32 bits \rightarrow upper 32 bits).
MULXS	B/W	$Rd \times Rs \rightarrow Rd$ Performs signed multiplication on data in two general registers: either 8 bits \times 8 bits \rightarrow 16 bits, or 16 bits \times 16 bits \rightarrow 32 bits.
MULS	W/L	$Rd \times Rs \rightarrow Rd$ Performs signed multiplication on data in two general registers: either 16 bits \times 16 bits \rightarrow 16 bits, or 32 bits \times 32 bits \rightarrow 32 bits.
MULS/U*	L	$Rd \times Rs \rightarrow Rd$ Performs signed multiplication on data in two general registers (32 bits \times 32 bits \rightarrow upper 32 bits).
DIVXU	B/W	$Rd \div Rs \rightarrow Rd$ Performs unsigned division on data in two general registers: either 16 bits \div 8 bits \rightarrow 8-bit quotient and 8-bit remainder, or 32 bits \div 16 bits \rightarrow 16-bit quotient and 16-bit remainder.

Instruction	Size	Function
DIVU	W/L	$Rd \div Rs \rightarrow Rd$ Performs unsigned division on data in two general registers: either 16 bits \div 16 bits \rightarrow 16-bit quotient, or 32 bits \div 32 bits \rightarrow 32-bit quotient.
DIVXS	B/W	$Rd \div Rs \rightarrow Rd$ Performs signed division on data in two general registers: either 16 bits \div 8 bits \rightarrow 8-bit quotient and 8-bit remainder, or 32 bits \div 16 bits \rightarrow 16-bit quotient and 16-bit remainder.
DIVS	W/L	$Rd \div Rs \rightarrow Rd$ Performs signed division on data in two general registers: either 16 bits \div 16 bits \rightarrow 16-bit quotient, or 32 bits \div 32 bits \rightarrow 32-bit quotient.
CMP	B/W/L	(EAd) – #IMM, (EAd) – (EAs) Compares data between immediate data, general registers, and memory and stores the result in CCR.
NEG	B/W/L	$0 - (EAd) \rightarrow (EAd)$ Takes the two's complement (arithmetic complement) of data in a general register or the contents of a memory location.
EXTU	W/L	(EAd) (zero extension) \rightarrow (EAd) Performs zero-extension on the lower 8 or 16 bits of data in a general register or memory to word or longword size. The lower 8 bits to word or longword, or the lower 16 bits to longword can be zero-extended.
EXTS	W/L	(EAd) (sign extension) \rightarrow (EAd) Performs sign-extension on the lower 8 or 16 bits of data in a general register or memory to word or longword size. The lower 8 bits to word or longword, or the lower 16 bits to longword can be sign-extended.
TAS	B	@ERd – 0, 1 \rightarrow (<bit 7> of @EAd) Tests memory contents, and sets the most significant bit (bit 7) to 1.
MAC*	—	(EAs) \times (EAd) + MAC \rightarrow MAC Performs signed multiplication on memory contents and adds the result to MAC.
CLRMAC*	—	$0 \rightarrow$ MAC Clears MAC to zero.
LDMAC*	—	$Rs \rightarrow$ MAC Loads data from a general register to MAC.
STMAC*	—	MAC \rightarrow Rd Stores data from MAC to a general register.

Note * Only when the multiplier is available.

Table 2.7 Logic Operation Instructions

Instruction	Size	Function
AND	B/W/L	$(EAd) \wedge \#IMM \rightarrow (EAd)$, $(EAd) \wedge (EAs) \rightarrow (EAd)$ Performs a logical AND operation on data between immediate data, general registers, and memory.
OR	B/W/L	$(EAd) \vee \#IMM \rightarrow (EAd)$, $(EAd) \vee (EAs) \rightarrow (EAd)$ Performs a logical OR operation on data between immediate data, general registers, and memory.
XOR	B/W/L	$(EAd) \oplus \#IMM \rightarrow (EAd)$, $(EAd) \oplus (EAs) \rightarrow (EAd)$ Performs a logical exclusive OR operation on data between immediate data, general registers, and memory.
NOT	B/W/L	$\sim (EAd) \rightarrow (EAd)$ Takes the one's complement of the contents of a general register or a memory location.

Table 2.8 Shift Operation Instructions

Instruction	Size	Function
SHLL	B/W/L	$(EAd) \text{ (shift)} \rightarrow (EAd)$
SHLR		Performs a logical shift on the contents of a general register or a memory location. The contents of a general register or a memory location can be shifted by 1, 2, 4, 8, or 16 bits. The contents of a general register can be shifted by any bits. In this case, the number of bits is specified by 5-bit immediate data or the lower 5 bits of the contents of a general register.
SHAL	B/W/L	$(EAd) \text{ (shift)} \rightarrow (EAd)$
SHAR		Performs an arithmetic shift on the contents of a general register or a memory location. 1-bit or 2-bit shift is possible.
ROTL	B/W/L	$(EAd) \text{ (rotate)} \rightarrow (EAd)$
ROTR		Rotates the contents of a general register or a memory location. 1-bit or 2-bit rotation is possible.
ROTXL	B/W/L	$(EAd) \text{ (rotate)} \rightarrow (EAd)$
ROTXR		Rotates the contents of a general register or a memory location with the carry bit. 1-bit or 2-bit rotation is possible.

Table 2.9 Bit Manipulation Instructions

Instruction	Size	Function
BSET	B	$1 \rightarrow (\text{<bit-No.> of <EAd>})$ Sets a specified bit in the contents of a general register or a memory location to 1. The bit number is specified by 3-bit immediate data or the lower three bits of a general register.
BSET/cc	B	$\text{if cc, } 1 \rightarrow (\text{<bit-No.> of <EAd>})$ If the specified condition is satisfied, this instruction sets a specified bit in a memory location to 1. The bit number can be specified by 3-bit immediate data, or by the lower three bits of a general register. The Z flag status can be specified as a condition.
BCLR	B	$0 \rightarrow (\text{<bit-No.> of <EAd>})$ Clears a specified bit in the contents of a general register or a memory location to 0. The bit number is specified by 3-bit immediate data or the lower three bits of a general register.
BCLR/cc	B	$\text{if cc, } 0 \rightarrow (\text{<bit-No.> of <EAd>})$ If the specified condition is satisfied, this instruction clears a specified bit in a memory location to 0. The bit number can be specified by 3-bit immediate data, or by the lower three bits of a general register. The Z flag status can be specified as a condition.
BNOT	B	$\sim (\text{<bit-No.> of <EAd>}) \rightarrow (\text{<bit-No.> of <EAd>})$ Inverts a specified bit in the contents of a general register or a memory location. The bit number is specified by 3-bit immediate data or the lower three bits of a general register.
BTST	B	$\sim (\text{<bit-No.> of <EAd>}) \rightarrow Z$ Tests a specified bit in the contents of a general register or a memory location and sets or clears the Z flag accordingly. The bit number is specified by 3-bit immediate data or the lower three bits of a general register.
BAND	B	$C \wedge (\text{<bit-No.> of <EAd>}) \rightarrow C$ ANDs the carry flag with a specified bit in the contents of a general register or a memory location and stores the result in the carry flag. The bit number is specified by 3-bit immediate data.
BIAND	B	$C \wedge [\sim (\text{<bit-No.> of <EAd>})] \rightarrow C$ ANDs the carry flag with the inverse of a specified bit in the contents of a general register or a memory location and stores the result in the carry flag. The bit number is specified by 3-bit immediate data.
BOR	B	$C \vee (\text{<bit-No.> of <EAd>}) \rightarrow C$ ORs the carry flag with a specified bit in the contents of a general register or a memory location and stores the result in the carry flag. The bit number is specified by 3-bit immediate data.

Instruction	Size	Function
BIOR	B	$C \vee [\sim (\text{<bit-No.> of <EAd>})] \rightarrow C$ ORs the carry flag with the inverse of a specified bit in the contents of a general register or a memory location and stores the result in the carry flag. The bit number is specified by 3-bit immediate data.
BXOR	B	$C \oplus (\text{<bit-No.> of <EAd>}) \rightarrow C$ Exclusive-ORs the carry flag with a specified bit in the contents of a general register or a memory location and stores the result in the carry flag. The bit number is specified by 3-bit immediate data.
BIXOR	B	$C \oplus [\sim (\text{<bit-No.> of <EAd>})] \rightarrow C$ Exclusive-ORs the carry flag with the inverse of a specified bit in the contents of a general register or a memory location and stores the result in the carry flag. The bit number is specified by 3-bit immediate data.
BLD	B	$(\text{<bit-No.> of <EAd>}) \rightarrow C$ Transfers a specified bit in the contents of a general register or a memory location to the carry flag. The bit number is specified by 3-bit immediate data.
BILD	B	$\sim (\text{<bit-No.> of <EAd>}) \rightarrow C$ Transfers the inverse of a specified bit in the contents of a general register or a memory location to the carry flag. The bit number is specified by 3-bit immediate data.
BST	B	$C \rightarrow (\text{<bit-No.> of <EAd>})$ Transfers the carry flag value to a specified bit in the contents of a general register or a memory location. The bit number is specified by 3-bit immediate data.
BSTZ	B	$Z \rightarrow (\text{<bit-No.> of <EAd>})$ Transfers the zero flag value to a specified bit in the contents of a memory location. The bit number is specified by 3-bit immediate data.
BIST	B	$\sim C \rightarrow (\text{<bit-No.> of <EAd>})$ Transfers the inverse of the carry flag value to a specified bit in the contents of a general register or a memory location. The bit number is specified by 3-bit immediate data.

Instruction	Size	Function
BISTZ	B	~ Z → (<bit-No.> of <EAd>) Transfers the inverse of the zero flag value to a specified bit in the contents of a memory location. The bit number is specified by 3-bit immediate data.
BFLD	B	(EAs) (bit field) → Rd Transfers a specified bit field in memory location contents to the lower bits of a specified general register.
BFST	B	Rs → (EAd) (bit field) Transfers the lower bits of a specified general register to a specified bit field in memory location contents.

Table 2.10 Branch Instructions

Instruction	Size	Function
BRA/BS BRA/BC	B	Tests a specified bit in memory location contents. If the specified condition is satisfied, execution branches to a specified address.
BSR/BS BSR/BC	B	Tests a specified bit in memory location contents. If the specified condition is satisfied, execution branches to a subroutine at a specified address.
Bcc	—	Branches to a specified address if the specified condition is satisfied.
BRA/S	—	Branches unconditionally to a specified address after executing the next instruction. The next instruction should be a 1-word instruction except for the block transfer and branch instructions.
JMP	—	Branches unconditionally to a specified address.
BSR	—	Branches to a subroutine at a specified address.
JSR	—	Branches to a subroutine at a specified address.
RTS	—	Returns from a subroutine.
RTS/L	—	Returns from a subroutine, restoring data from the stack to multiple general registers.

Table 2.11 System Control Instructions

Instruction	Size	Function
TRAPA	—	Starts trap-instruction exception handling.
RTE	—	Returns from an exception-handling routine.
RTE/L	—	Returns from an exception-handling routine, restoring data from the stack to multiple general registers.
SLEEP	—	Causes a transition to a power-down state.
LDC	B/W	#IMM → CCR, (EAs) → CCR, #IMM → EXR, (EAs) → EXR Loads immediate data or the contents of a general register or a memory location to CCR or EXR. Although CCR and EXR are 8-bit registers, word-size transfers are performed between them and memory. The upper 8 bits are valid.
	L	Rs → VBR, Rs → SBR Transfers the general register contents to VBR or SBR.
STC	B/W	CCR → (EAd), EXR → (EAd) Transfers the contents of CCR or EXR to a general register or memory. Although CCR and EXR are 8-bit registers, word-size transfers are performed between them and memory. The upper 8 bits are valid.
	L	VBR → Rd, SBR → Rd Transfers the contents of VBR or SBR to a general register.
ANDC	B	CCR ∧ #IMM → CCR, EXR ∧ #IMM → EXR Logically ANDs the CCR or EXR contents with immediate data.
ORC	B	CCR ∨ #IMM → CCR, EXR ∨ #IMM → EXR Logically ORs the CCR or EXR contents with immediate data.
XORC	B	CCR ⊕ #IMM → CCR, EXR ⊕ #IMM → EXR Logically exclusive-ORs the CCR or EXR contents with immediate data.
NOP	—	PC + 2 → PC Only increments the program counter.

2.7.3 Basic Instruction Formats

The H8SX CPU instructions consist of 2-byte (1-word) units. An instruction consists of an operation field (op field), a register field (r field), an effective address extension (EA field), and a condition field (cc).

Figure 2.14 shows examples of instruction formats.

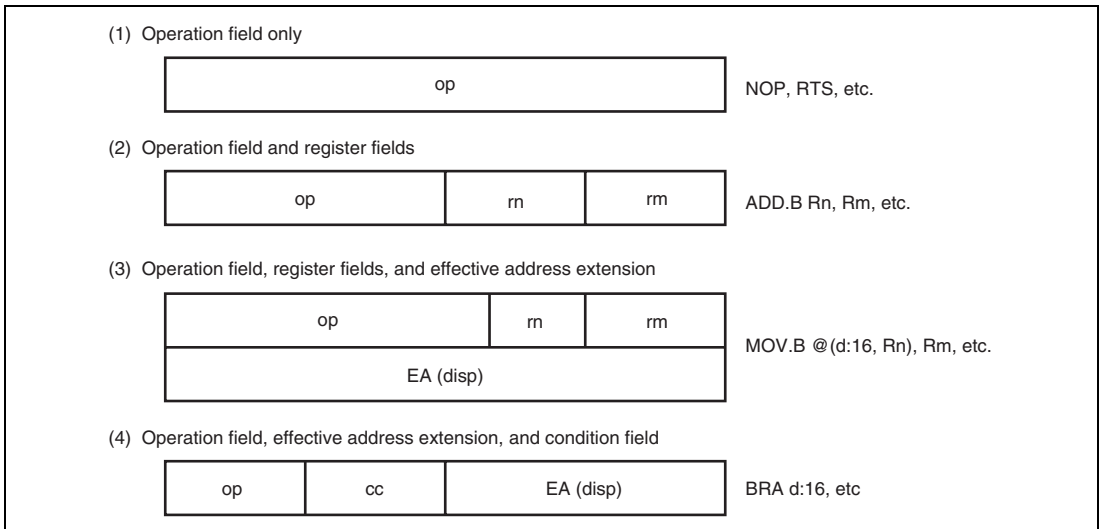

Figure 2.14 Instruction Formats

- **Operation Field**
Indicates the function of the instruction, and specifies the addressing mode and operation to be carried out on the operand. The operation field always includes the first four bits of the instruction. Some instructions have two operation fields.
- **Register Field**
Specifies a general register. Address registers are specified by 3 bits, data registers by 3 bits or 4 bits. Some instructions have two register fields. Some have no register field.
- **Effective Address Extension**
8, 16, or 32 bits specifying immediate data, an absolute address, or a displacement.
- **Condition Field**
Specifies the branch condition of Bcc instructions.

2.8 Addressing Modes and Effective Address Calculation

The H8SX CPU supports the 11 addressing modes listed in table 2.12. Each instruction uses a subset of these addressing modes.

Bit manipulation instructions use register direct, register indirect, or absolute addressing mode to specify an operand, and register direct (BSET, BCLR, BNOT, and BTST instructions) or immediate (3-bit) addressing mode to specify a bit number in the operand.

Table 2.12 Addressing Modes

No.	Addressing Mode	Symbol
1	Register direct	Rn
2	Register indirect	@ERn
3	Register indirect with displacement	@(d:2,ERn)/@(d:16,ERn)/@(d:32,ERn)
4	Index register indirect with displacement	@(d:16, RnL.B)/@(d:16,Rn.W)/@(d:16,ERn.L) @(d:32, RnL.B)/@(d:32,Rn.W)/@(d:32,ERn.L)
5	Register indirect with post-increment	@ERn+
	Register indirect with pre-decrement	@-ERn
	Register indirect with pre-increment	@+ERn
	Register indirect with post-decrement	@ERn-
6	Absolute address	@aa:8/@aa:16/@aa:24/@aa:32
7	Immediate	#xx:3/#xx:4/#xx:8/#xx:16/#xx:32
8	Program-counter relative	@(d:8,PC)/@(d:16,PC)
9	Program-counter relative with index register	@(RnL.B,PC)/@(Rn.W,PC)/@(ERn.L,PC)
10	Memory indirect	@@aa:8
11	Extended memory indirect	@@vec:7

2.8.1 Register Direct—Rn

The operand value is the contents of an 8-, 16-, or 32-bit general register which is specified by the register field in the instruction code.

R0H to R7H and R0L to R7L can be specified as 8-bit registers.

R0 to R7 and E0 to E7 can be specified as 16-bit registers.

ER0 to ER7 can be specified as 32-bit registers.

2.8.2 Register Indirect—@ERn

The operand value is the contents of the memory location which is pointed to by the contents of an address register (ERn). ERn is specified by the register field of the instruction code.

In advanced mode, if this addressing mode is used in a branch instruction, the lower 24 bits are valid and the upper 8 bits are all assumed to be 0 (H'00).

2.8.3 Register Indirect with Displacement —@(d:2, ERn), @(d:16, ERn), or @(d:32, ERn)

The operand value is the contents of a memory location which is pointed to by the sum of the contents of an address register (ERn) and a 16- or 32-bit displacement. ERn is specified by the register field of the instruction code. The displacement is included in the instruction code and the 16-bit displacement is sign-extended when added to ERn.

This addressing mode has a short format (@(d:2, ERn)). The short format can be used when the displacement is 1, 2, or 3 and the operand is byte data, when the displacement is 2, 4, or 6 and the operand is word data, or when the displacement is 4, 8, or 12 and the operand is longword data.

2.8.4 Index Register Indirect with Displacement—@(d:16,RnL.B), @(d:32,RnL.B), @(d:16,Rn.W), @(d:32,Rn.W), @(d:16,ERn.L), or @(d:32,ERn.L)

The operand value is the contents of a memory location which is pointed to by the sum of the following operation result and a 16- or 32-bit displacement: a specified bits of the contents of an address register (RnL, Rn, ERn) specified by the register field in the instruction code are zero-extended to 32-bit data and multiplied by 1, 2, or 4. The displacement is included in the instruction code and the 16-bit displacement is sign-extended when added to ERn. If the operand is byte data, ERn is multiplied by 1. If the operand is word or longword data, ERn is multiplied by 2 or 4, respectively.

2.8.5 Register Indirect with Post-Increment, Pre-Decrement, Pre-Increment, or Post-Decrement—@ERn+, @-ERn, @+ERn, or @ERn-

- Register indirect with post-increment—@ERn+
The operand value is the contents of a memory location which is pointed to by the contents of an address register (ERn). ERn is specified by the register field of the instruction code. After the memory location is accessed, 1, 2, or 4 is added to the address register contents and the sum is stored in the address register. The value added is 1 for byte access, 2 for word access, or 4 for longword access.
- Register indirect with pre-decrement—@-ERn
The operand value is the contents of a memory location which is pointed to by the following operation result: the value 1, 2, or 4 is subtracted from the contents of an address register (ERn). ERn is specified by the register field of the instruction code. After that, the operand value is stored in the address register. The value subtracted is 1 for byte access, 2 for word access, or 4 for longword access.
- Register indirect with pre-increment—@+ERn
The operand value is the contents of a memory location which is pointed to by the following operation result: the value 1, 2, or 4 is added to the contents of an address register (ERn). ERn is specified by the register field of the instruction code. After that, the operand value is stored in the address register. The value added is 1 for byte access, 2 for word access, or 4 for longword access.
- Register indirect with post-decrement—@ERn-
The operand value is the contents of a memory location which is pointed to by the contents of an address register (ERn). ERn is specified by the register field of the instruction code. After the memory location is accessed, 1, 2, or 4 is subtracted from the address register contents and the remainder is stored in the address register. The value subtracted is 1 for byte access, 2 for word access, or 4 for longword access.

using this addressing mode, data to be written is the contents of the general register after calculating an effective address. If the same general register is specified in an instruction and two effective addresses are calculated, the contents of the general register after the first calculation of an effective address is used in the second calculation of an effective address.

Example 1:

```
MOV.W    R0, @ER0+
```

When ER0 before execution is H'12345678, H'567A is written at H'12345678.

Example 2:

MOV.B @ER0+, @ER0+

When ER0 before execution is H'00001000, H'00001000 is read and the contents is written at H'00001001.

After execution, ER0 is H'00001002.

2.8.6 Absolute Address—@aa:8, @aa:16, @aa:24, or @aa:32

The operand value is the contents of a memory location which is pointed to by an absolute address included in the instruction code.

There are 8-bit (@aa:8), 16-bit (@aa:16), 24-bit (@aa:24), and 32-bit (@aa:32) absolute addresses.

To access the data area, the absolute address of 8 bits (@aa:8), 16 bits (@aa:16), or 32 bits (@aa:32) is used. For an 8-bit absolute address, the upper 24 bits are specified by SBR. For a 16-bit absolute address, the upper 16 bits are sign-extended. A 32-bit absolute address can access the entire address space.

To access the program area, the absolute address of 24 bits (@aa:24) or 32 bits (@aa:32) is used. For a 24-bit absolute address, the upper 8 bits are all assumed to be 0 (H'00).

Table 2.13 shows the accessible absolute address ranges.

Table 2.13 Absolute Address Access Ranges

Absolute Address	Normal Mode	Middle Mode	Advanced Mode	Maximum Mode
Data area	A consecutive 256-byte area (the upper address is set in SBR)			
8 bits (@aa:8)				
16 bits (@aa:16)	H'0000 to H'FFFF	H'000000 to H'007FFF,	H'00000000 to H'00007FFF, H'FFFF8000 to H'FFFFFFFF	
32 bits (@aa:32)	H'FF8000 to H'FFFFFF		H'00000000 to H'FFFFFFFF	
Program area				
24 bits (@aa:24)	H'000000 to H'FFFFFF		H'00000000 to H'00FFFFFF	
32 bits (@aa:32)			H'00000000 to H'00FFFFFF	H'00000000 to H'FFFFFFFF

2.8.7 Immediate—#xx

The operand value is 8-bit (#xx:8), 16-bit (#xx:16), or 32-bit (#xx:32) data included in the instruction code.

This addressing mode has short formats in which 3- or 4-bit immediate data can be used.

When the size of immediate data is less than that of the destination operand value (byte, word, or longword) the immediate data is zero-extended.

The ADDS, SUBS, INC, and DEC instructions contain immediate data implicitly. Some bit manipulation instructions contain 3-bit immediate data in the instruction code, for specifying a bit number. The BFLD and BFST instructions contain 8-bit immediate data in the instruction code, for specifying a bit field. The TRAPA instruction contains 2-bit immediate data in the instruction code, for specifying a vector address.

2.8.8 Program-Counter Relative—@(d:8, PC) or @(d:16, PC)

This mode is used in the Bcc and BSR instructions. The operand value is a 32-bit branch address, which is the sum of an 8- or 16-bit displacement in the instruction code and the 32-bit address of the PC contents. The 8-bit or 16-bit displacement is sign-extended to 32 bits when added to the PC contents. The PC contents to which the displacement is added is the address of the first byte of the next instruction, so the possible branching range is -126 to +128 bytes (-63 to +64 words) or -32766 to +32768 bytes (-16383 to +16384 words) from the branch instruction. The resulting value should be an even number. In advanced mode, only the lower 24 bits of this branch address are valid; the upper 8 bits are all assumed to be 0 (H'00).

2.8.9 Program-Counter Relative with Index Register—@(RnL.B, PC), @(Rn.W, PC), or @(ERn.L, PC)

This mode is used in the Bcc and BSR instructions. The operand value is a 32-bit branch address, which is the sum of the following operation result and the 32-bit address of the PC contents: the contents of an address register specified by the register field in the instruction code (RnL, Rn, or ERn) is zero-extended and multiplied by 2. The PC contents to which the displacement is added is the address of the first byte of the next instruction. In advanced mode, only the lower 24 bits of this branch address are valid; the upper 8 bits are all assumed to be 0 (H'00).

2.8.10 Memory Indirect—@@aa:8

This mode can be used by the JMP and JSR instructions. The operand value is a branch address, which is the contents of a memory location pointed to by an 8-bit absolute address in the instruction code.

The upper bits of an 8-bit absolute address are all assumed to be 0, so the address range is 0 to 255 (H'0000 to H'00FF in normal mode, H'000000 to H'0000FF in other modes).

In normal mode, the memory location is pointed to by word-size data and the branch address is 16 bits long. In other modes, the memory location is pointed to by longword-size data. In middle or advanced mode, the first byte of the longword-size data is assumed to be all 0 (H'00).

Note that the top part of the address range is also used as the exception handling vector area. A vector address of an exception handling other than a reset or a CPU address error can be changed by VBR.

Figure 2.15 shows an example of specification of a branch address using this addressing mode.

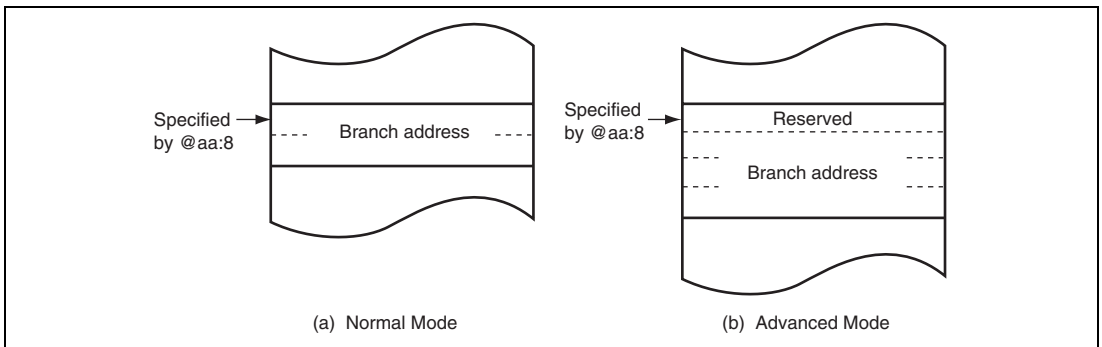

Figure 2.15 Branch Address Specification in Memory Indirect Mode

2.8.11 Extended Memory Indirect—@@vec:7

This mode can be used by the JMP and JSR instructions. The operand value is a branch address, which is the contents of a memory location pointed to by the following operation result: the sum of 7-bit data in the instruction code and the value of H'80 is multiplied by 2 or 4.

The address range to store a branch address is H'0100 to H'01FF in normal mode and H'000200 to H'0003FF in other modes. In assembler notation, an address to store a branch address is specified.

In normal mode, the memory location is pointed to by word-size data and the branch address is 16 bits long. In other modes, the memory location is pointed to by longword-size data. In middle or advanced mode, the first byte of the longword-size data is assumed to be all 0 (H'00).

2.8.12 Effective Address Calculation

Tables 2.14 and 2.15 show how effective addresses are calculated in each addressing mode. The lower bits of the effective address are valid and the upper bits are ignored (zero extended or sign extended) according to the CPU operating mode.

The valid bits in middle mode are as follows:

- The lower 16 bits of the effective address are valid and the upper 16 bits are sign-extended for the transfer and operation instructions.
- The lower 24 bits of the effective address are valid and the upper eight bits are zero-extended for the branch instructions.

Table 2.14 Effective Address Calculation for Transfer and Operation Instructions











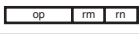
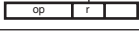

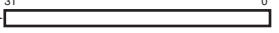
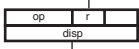
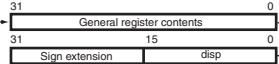
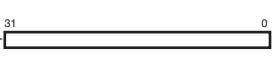

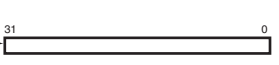
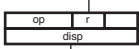
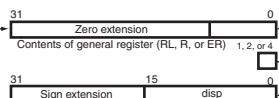
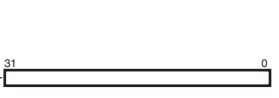

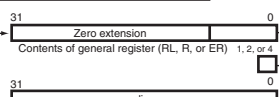
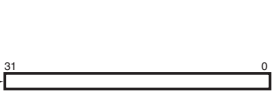

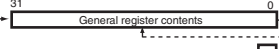
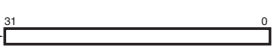



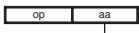
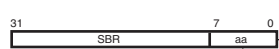
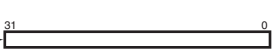
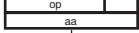
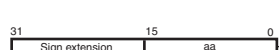

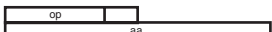

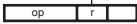

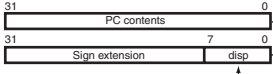
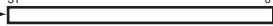
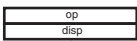
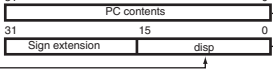

No.	Addressing Mode and Instruction Format	Effective Address Calculation	Effective Address (EA)
1	Immediate 		
2	Register direct 		
3	Register indirect 		
4	Register indirect with 16-bit displacement 		
	Register indirect with 32-bit displacement 		
5	Index register indirect with 16-bit displacement 		
	Index register indirect with 32-bit displacement 		
6	Register indirect with post-increment or post-decrement 		
	Register indirect with pre-increment or pre-decrement 		
7	8-bit absolute address 		
	16-bit absolute address 		
	32-bit absolute address 		

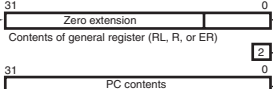
Table 2.15 Effective Address Calculation for Branch Instructions

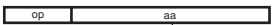
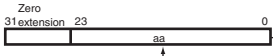
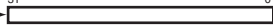
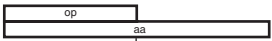
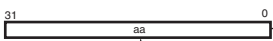
No.	Addressing Mode and Instruction Format	Effective Address Calculation	Effective Address (EA)
1	Register indirect 		
2	Program-counter relative with 8-bit displacement 		
	Program-counter relative with 16-bit displacement 		
3	Program-counter relative with index register 		
4	24-bit absolute address 		
	32-bit absolute address 		
5	Memory indirect 		
6	Extended memory indirect 		

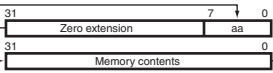
2.8.13 MOVA Instruction

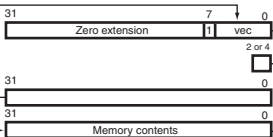
The MOVA instruction stores the effective address in a general register.

1. Firstly, data is obtained by the addressing mode shown in item 2 of table 2.14.
2. Next, the effective address is calculated using the obtained data as the index by the addressing mode shown in item 5 of table 2.14. The obtained data is used instead of the general register. The result is stored in a general register. For details, see H8SX Family Software Manual.

2.9 Processing States

The H8SX CPU has five main processing states: the reset state, exception-handling state, program execution state, bus-released state, and program stop state. Figure 2.16 indicates the state transitions.

- Reset state

In this state the CPU and internal peripheral modules are all initialized and stopped. When the $\overline{\text{RES}}$ input goes low, all current processing stops and the CPU enters the reset state. All interrupts are masked in the reset state. Reset exception handling starts when the $\overline{\text{RES}}$ signal changes from low to high. For details, see section 6, Exception Handling.

The reset state can also be entered by a watchdog timer overflow when available.

- Exception-handling state

The exception-handling state is a transient state that occurs when the CPU alters the normal processing flow due to activation of an exception source, such as, a reset, trace, interrupt, or trap instruction. The CPU fetches a start address (vector) from the exception handling vector table and branches to that address. For further details, see section 6, Exception Handling.

- Program execution state

In this state the CPU executes program instructions in sequence.

- Bus-released state

The bus-released state occurs when the bus has been released in response to a bus request from a bus master other than the CPU. While the bus is released, the CPU halts operations.

- Program stop state

This is a power-down state in which the CPU stops operating. The program stop state occurs when a SLEEP instruction is executed or the CPU enters hardware standby mode. For details, see section 25, Power-Down Modes.

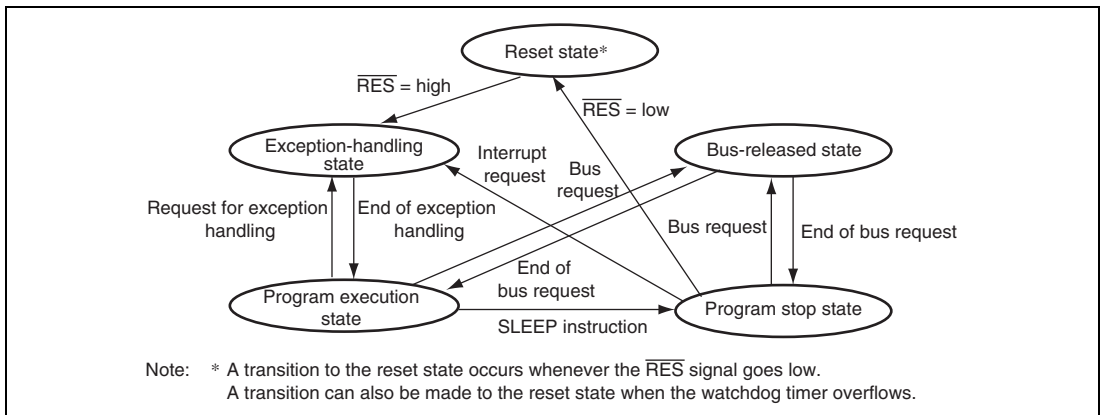

Figure 2.16 State Transitions

Section 3 MCU Operating Modes

3.1 Operating Mode Selection

This LSI has seven operating modes (modes 1, 2, 3, 4, 5, 6, and 7). The operating mode is selected by the setting of mode pins MD2 to MD0. Table 3.1 lists MCU operating mode settings.

Table 3.1 MCU Operating Mode Settings

MCU Operating Mode	MD2	MD1	MD0	CPU Operating Mode	Address Space	LSI Initiation Mode	On-Chip ROM	External Data Bus Width	
								Default	Max.
1	0	0	1	Advanced mode	16 Mbytes	User boot mode	Enabled	—	16 bits
2	0	1	0			Boot mode	Enabled	—	16 bits
3	0	1	1			Boundary scan enabled single-chip mode	Enabled	—	16 bits
4	1	0	0	On-chip ROM disabled extended mode		On-chip ROM disabled extended mode	Disabled	16 bits	16 bits
5	1	0	1			Disabled	8 bits	16 bits	
6	1	1	0	On-chip ROM enabled extended mode		Enabled	8 bits	16 bits	
7	1	1	1	Single-chip mode		Enabled	—	16 bits	

In this LSI, an advanced mode as the CPU operating mode and a 16-Mbyte address space are available. The initial external bus widths are 8 bits or 16 bits. As the LSI initiation mode, the external extended mode, on-chip ROM initiation mode, or single-chip initiation mode can be selected.

Modes 1 and 2 are the user boot mode and the boot mode, respectively, in which the flash memory can be programmed and erased. For details on the user boot mode and boot mode, see section 22, Flash Memory.

Mode 3 is the boundary scan function enabled single-chip mode. For details on the boundary scan function, see section 23, Boundary Scan.

Mode 7 is a single-chip initiation mode. All I/O ports can be used as general input/output ports. The external address space cannot be accessed in the initial state, but setting the EXPE bit in the system control register (SYSCR) to 1 enables to use the external address space. After the external address space is enabled, ports D, E, and F can be used as an address output bus and ports H and I as a data bus by specifying the data direction register (DDR) for each port. When the external

address space is not in use, ports J and K can be used by setting the PCJKE bit in the port function control register D (PFCRD) to 1.

Modes 4 to 6 are external extended modes, in which the external memory and devices can be accessed. In the external extended modes, the external address space can be designated as 8-bit or 16-bit address space for each area by the bus controller after starting program execution.

If 16-bit address space is designated for any one area, it is called the 16-bit bus widths mode. If 8-bit address space is designated for all areas, it is called the 8-bit bus width mode.

3.2 Register Descriptions

The following registers are related to the operating mode setting.

- Mode control register (MDCR)
- System control register (SYSCR)

3.2.1 Mode Control Register (MDCR)

MDCR indicates the current operating mode. When MDCR is read from, the states of signals MD3 to MD0 are latched. Latching is released by a reset.

Bit	15	14	13	12	11	10	9	8
Bit Name	—	—	—	—	MDS3	MDS2	MDS1	MDS0
Initial Value	0	1	0	1	Undefined*	Undefined*	Undefined*	Undefined*
R/W	R	R	R	R	R	R	R	R
Bit	7	6	5	4	3	2	1	0
Bit Name	—	—	—	—	—	—	—	—
Initial Value	0	1	0	1	Undefined*	Undefined*	Undefined*	Undefined*
R/W	R	R	R	R	R	R	R	R

Note: * Determined by pins MD2 to MD0.

Bit	Bit Name	Initial Value	R/W	Descriptions
15	—	0	R	Reserved
14	—	1	R	These are read-only bits and cannot be modified.
13	—	0	R	
12	—	1	R	
11	MDS3	Undefined*	R	Mode Select 3 to 0
10	MDS2	Undefined*	R	These bits indicate the operating mode selected by the mode pins (MD2 to MD0) (see table 3.2). When MDCR is read, the signal levels input on pins MD2 to MD0 are latched into these bits. These latches are released by a reset.
9	MDS1	Undefined*	R	
8	MDS0	Undefined*	R	
7	—	0	R	Reserved
6	—	1	R	These are read-only bits and cannot be modified.
5	—	0	R	
4	—	1	R	
3	—	Undefined*	R	
2	—	Undefined*	R	
1	—	Undefined*	R	
0	—	Undefined*	R	

Note: * Determined by pins MD2 to MD0.

Table 3.2 Settings of Bits MDS3 to MDS0

MCU Operating Mode	Mode Pins			MDCR			
	MD2	MD1	MD0	MDS3	MDS2	MDS1	MDS0
1	0	0	1	1	1	0	1
2	0	1	0	1	1	0	0
3	0	1	1	0	1	0	0
4	1	0	0	0	0	1	0
5	1	0	1	0	0	0	1
6	1	1	0	0	1	0	1
7	1	1	1	0	1	0	0

3.2.2 System Control Register (SYSCR)

SYSCR controls MAC saturation operation, selects bus width mode for instruction fetch, sets external bus mode, enables/disables the on-chip RAM, and selects the DTC address mode.

Bit	15	14	13	12	11	10	9	8
Bit Name	—	—	MACS	—	FETCHMD	—	EXPE	RAME
Initial Value	1	1	0	1	0	Undefined*	Undefined*	1
R/W	R/W	R/W	R/W	R/W	R/W	R	R/W	R/W
Bit	7	6	5	4	3	2	1	0
Bit Name	—	—	—	—	—	—	DTCMD	—
Initial Value	0	0	0	0	0	0	1	1
R/W	R/W	R/W	R/W	R/W	R/W	R/W	R/W	R/W

Note: * The initial value depends on the startup mode.

Bit	Bit Name	Initial Value	R/W	Descriptions
15	—	1	R/W	Reserved
14	—	1	R/W	These bits are always read as 1. The write value should always be 1.
13	MACS	0	R/W	MAC Saturation Operation Control Selects either saturation operation or non-saturation operation for the MAC instruction. 0: MAC instruction is non-saturation operation 1: MAC instruction is saturation operation
12	—	1	R/W	Reserved This bit is always read as 1. The write value should always be 1.
11	FETCHMD	0	R/W	Instruction Fetch Mode Select This LSI can prefetch an instruction in units of 16 bits or 32 bits. Select the bus width for instruction fetch depending on the used memory for the storage of programs* ¹ . 0: 32-bit mode 1: 16-bit mode

Bit	Bit Name	Initial Value	R/W	Descriptions
10	—	Undefined* ¹	R	Reserved This bit is fixed at 1 in on-chip ROM enabled mode, and 0 in on-chip ROM disabled mode. This bit cannot be changed.
9	EXPE	Undefined* ¹	R/W	External Bus Mode Enable Selects external bus mode. In external extended mode, this bit is fixed 1 and cannot be changed. In single-chip mode, the initial value of this bit is 0, and can be read from or written to when PCKJE = 0. Do not write to this bit when PCKJE = 1* ² . When writing 0 to this bit after reading EXPE = 1, an external bus cycle should not be executed. The external bus cycle may be carried out in parallel with the internal bus cycle depending on the setting of the write data buffer function. 0: External bus disabled 1: External bus enabled
8	RAME	1	R/W	RAM Enable Enables or disables the on-chip RAM. This bit is initialized when the reset state is released. Do not write 0 during access to the on-chip RAM. 0: On-chip RAM disabled 1: On-chip RAM enabled
7 to 2	—	All 0	R/W	Reserved These bits are always read as 0. The write value should always be 0.
1	DTCMD	1	R/W	DTC Mode Select Selects DTC operating mode. 0: DTC is in full-address mode 1: DTC is in short address mode
0	—	1	R/W	Reserved This bit is always read as 1. The write value should always be 1.

Notes: 1. The initial value depends on the LSI initiation mode.

2. For details on the settings of the EXPE and PCJKE bits when the external address space is in use, see section 12.3.11, Port Function Control Register D (PFCRD).

3.3 Operating Mode Descriptions

3.3.1 Mode 1

This is the user boot mode for the flash memory. The LSI operates in the same way as in mode 7 except for programming and erasing of the flash memory. For details, see section 22, Flash Memory.

3.3.2 Mode 2

This is the boot mode for the flash memory. The LSI operates in the same way as in mode 7 except for programming and erasing of the flash memory. For details, see section 22, Flash Memory.

3.3.3 Mode 3

This is the boundary scan function enabled single-chip activation mode. The operation is the same as mode 7 except for the boundary scan function. For details on the boundary scan function, see section 23, Boundary Scan.

3.3.4 Mode 4

The CPU operating mode is advanced mode in which the address space is 16 Mbytes, and the on-chip ROM is disabled.

The initial bus width mode immediately after a reset is 16 bits, with 16-bit access to all areas. Ports D, E, and F function as an address bus, ports H and I function as a data bus, and parts of ports A and B function as bus control signals. However, if all areas are designated as an 8-bit access space by the bus controller, the bus mode switches to 8 bits, and only port H functions as a data bus.

3.3.5 Mode 5

The CPU operating mode is advanced mode in which the address space is 16 Mbytes, and the on-chip ROM is disabled.

The initial bus width mode immediately after a reset is eight bits, with 8-bit access to all areas. Ports D, E, and F function as an address bus, port H functions as a data bus, and parts of ports A and B function as bus control signals. However, if any area is designated as a 16-bit access space by the bus controller, the bus width mode switches to 16 bits, and ports H and I function as a data bus.

3.3.6 Mode 6

The CPU operating mode is advanced mode in which the address space is 16 Mbytes, and the on-chip ROM is enabled.

The initial bus width mode immediately after a reset is eight bits, with 8-bit access to all areas. Ports D, E, and F function as input ports, but they can be used as an address bus by specifying the data direction register (DDR) for each port. For details, see section 12, I/O Ports. Port H functions as a data bus, and parts of ports A and B function as bus control signals. However, if any area is designated as a 16-bit access space by the bus controller, the bus width mode switches to 16 bits, and ports H and I function as a data bus.

3.3.7 Mode 7

The CPU operating mode is advanced mode in which the address space is 16 Mbytes, and the on-chip ROM is enabled.

All I/O ports can be used as general input/output ports. The external address space cannot be accessed in the initial state, but setting the EXPE bit in the system control register (SYSCR) to 1 enables the external address space. After the external address space is enabled, ports D, E, and F can be used as an address output bus and ports H and I as a data bus by specifying the data direction register (DDR) for each port. When the external address space is not in use, ports J and K can be used by setting the PCJKE bit in the port function control register D (PFCRD) to 1. For details, see section 12, I/O Ports.

3.3.8 Pin Functions

Table 3.3 lists the pin functions in each operating mode.

Table 3.3 Pin Functions in Each Operating Mode (Advanced Mode)

MCU Operating Mode	Port A			Port B				Port F			
	PA7	PA6 to PA3	PA2 to PA0	PB3 to PB1	PB0	Port D	Port E	PF4 to PF0	PF7 to PF5	Port H	Port I
1	P*/C	P*/C	P*/C	P*/C	P*/C	P*/A	P*/A	P*/A	P*/A/C	P*/D	P*/D
2	P*/C	P*/C	P*/C	P*/C	P*/C	P*/A	P*/A	P*/A	P*/A/C	P*/D	P*/D
3	P*/C	P*/C	P*/C	P*/C	P*/C	P*/A	P*/A	P*/A	P*/A/C	P*/D	P*/D
4	P/C*	P/C*	P*/C	P*/C	P/C*	A	A	A	P*/A/C	D	P/D*
5	P/C*	P/C*	P*/C	P*/C	P/C*	A	A	A	P*/A/C	D	P*/D
6	P/C*	P/C*	P*/C	P*/C	P*/C	P*/A	P*/A	P*/A	P*/A/C	D	P*/D
7	P*/C	P*/C	P*/C	P*/C	P*/C	P*/A	P*/A	P*/A	P*/A/C	P*/D	P*/D

[Legend]

P: I/O port

A: Address bus output

D: Data bus input/output

C: Control signals, clock input/output

*: Immediately after a reset

3.4 Address Map

3.4.1 Address Map

Figures 3.1 to 3.3 show the address map in each operating mode.

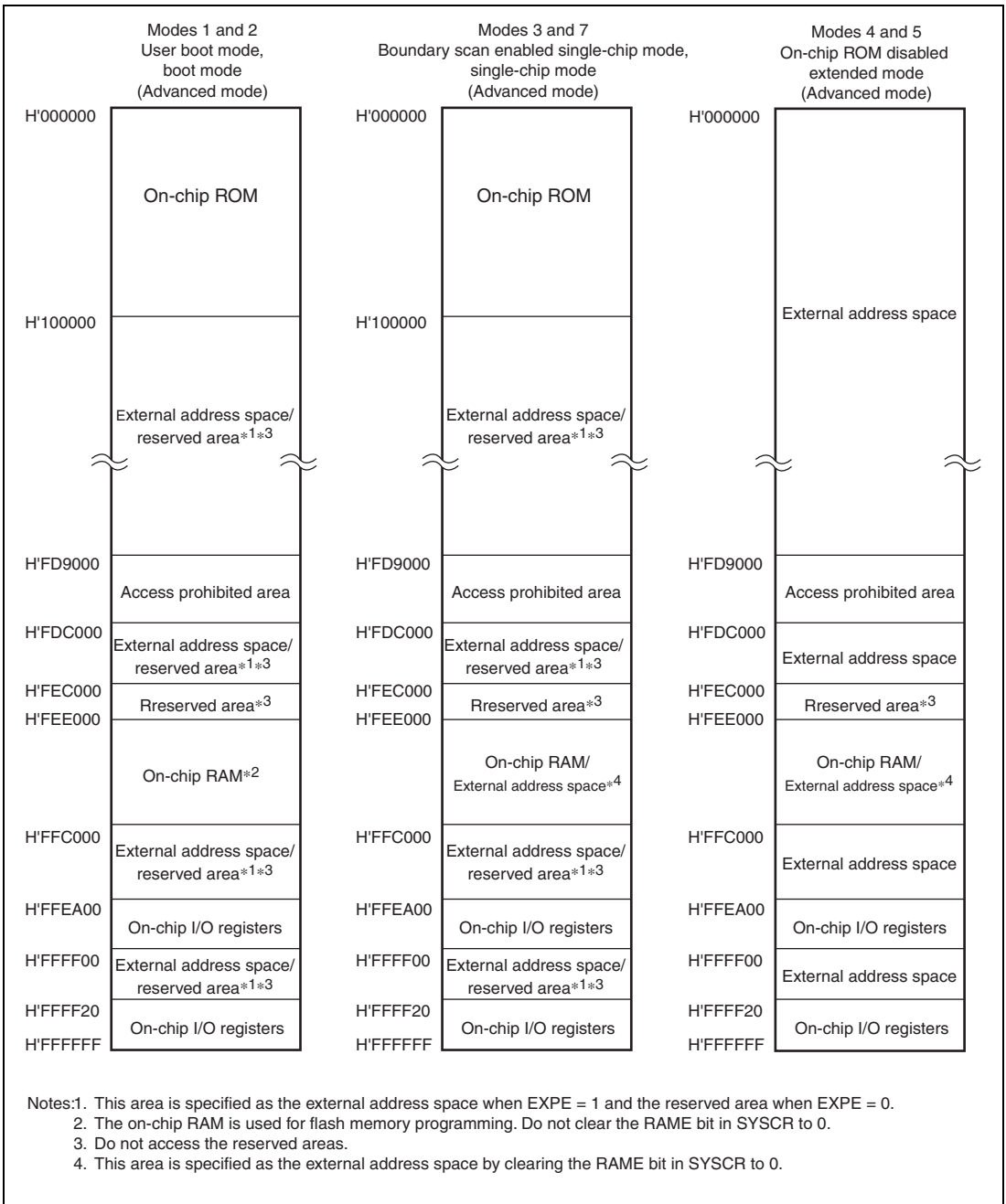
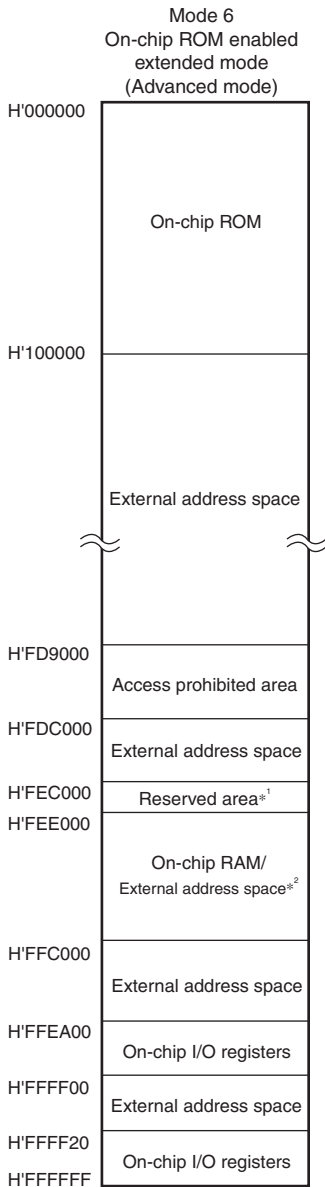

Figure 3.1 Address Map in Each Operating Mode of H8SX/1638 and H8SX/1638L (1)



Notes: 1. Do not access the reserved area.
 2. This area is specified as the external address space by clearing the RAME bit in SYSCR to 0.

Figure 3.1 Address Map in Each Operating Mode of H8SX/1638 and H8SX/1638L (2)

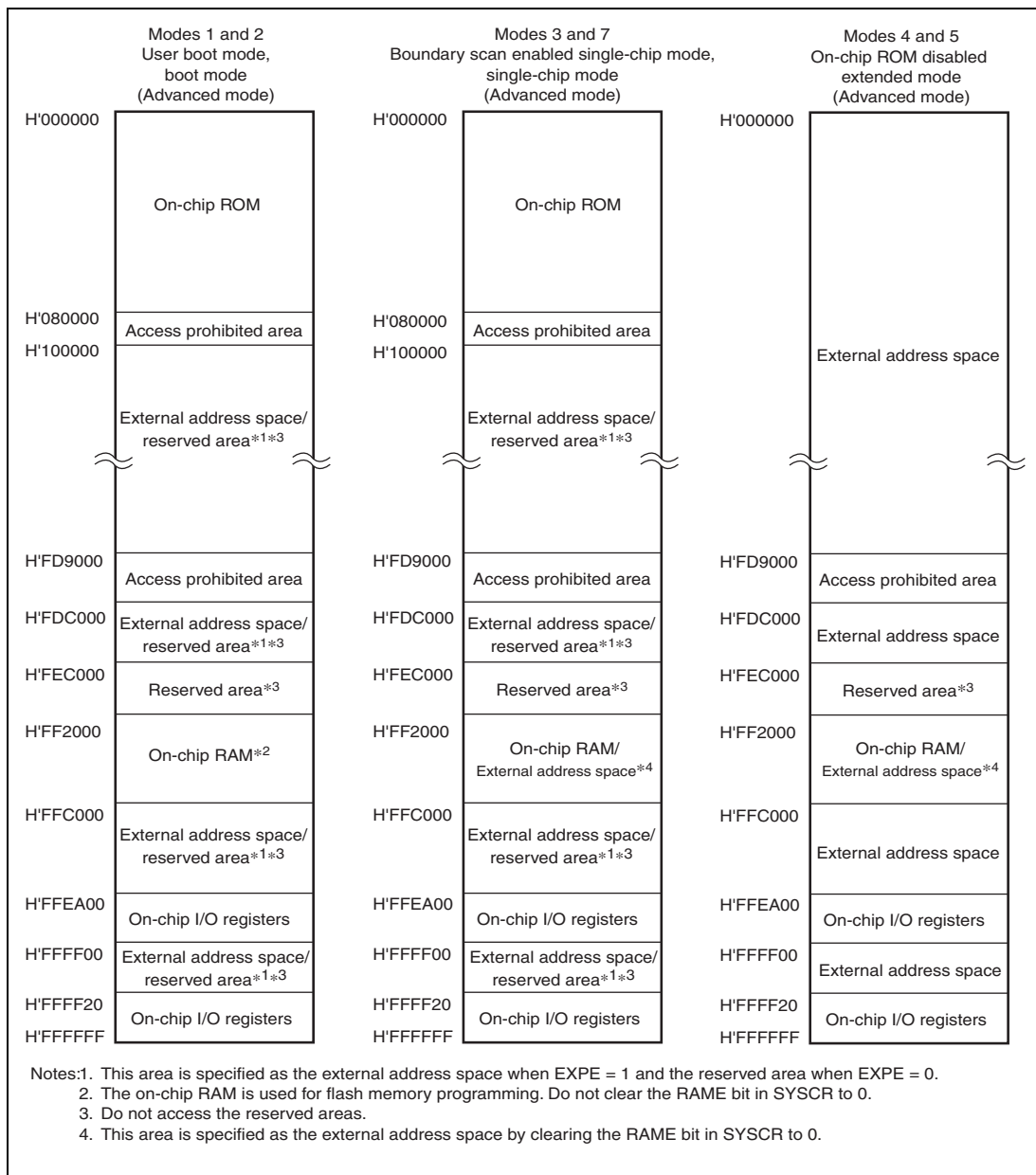
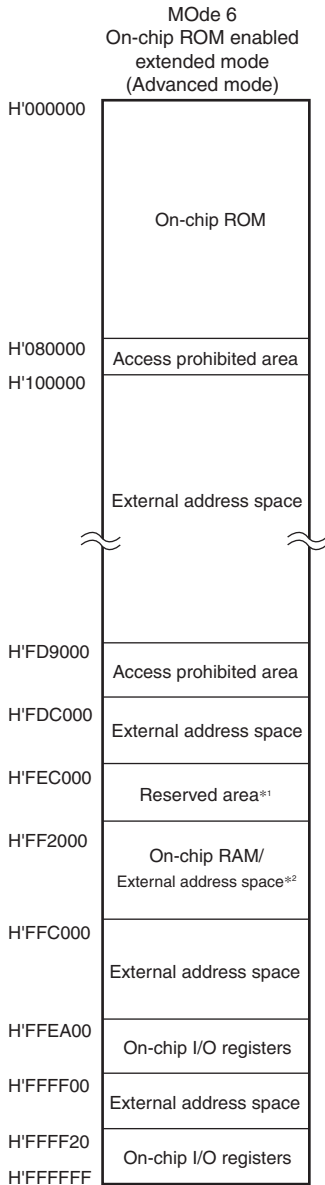

Figure 3.2 Address Map in Each Operating Mode of H8SX/1634 and H8SX/1634L (1)



- Notes: 1. Do not access the reserved area.
2. This area is specified as the external address space by clearing the RAME bit in SYSCR to 0.

Figure 3.2 Address Map in Each Operating Mode of H8SX/1634 and H8SX/1634L (2)

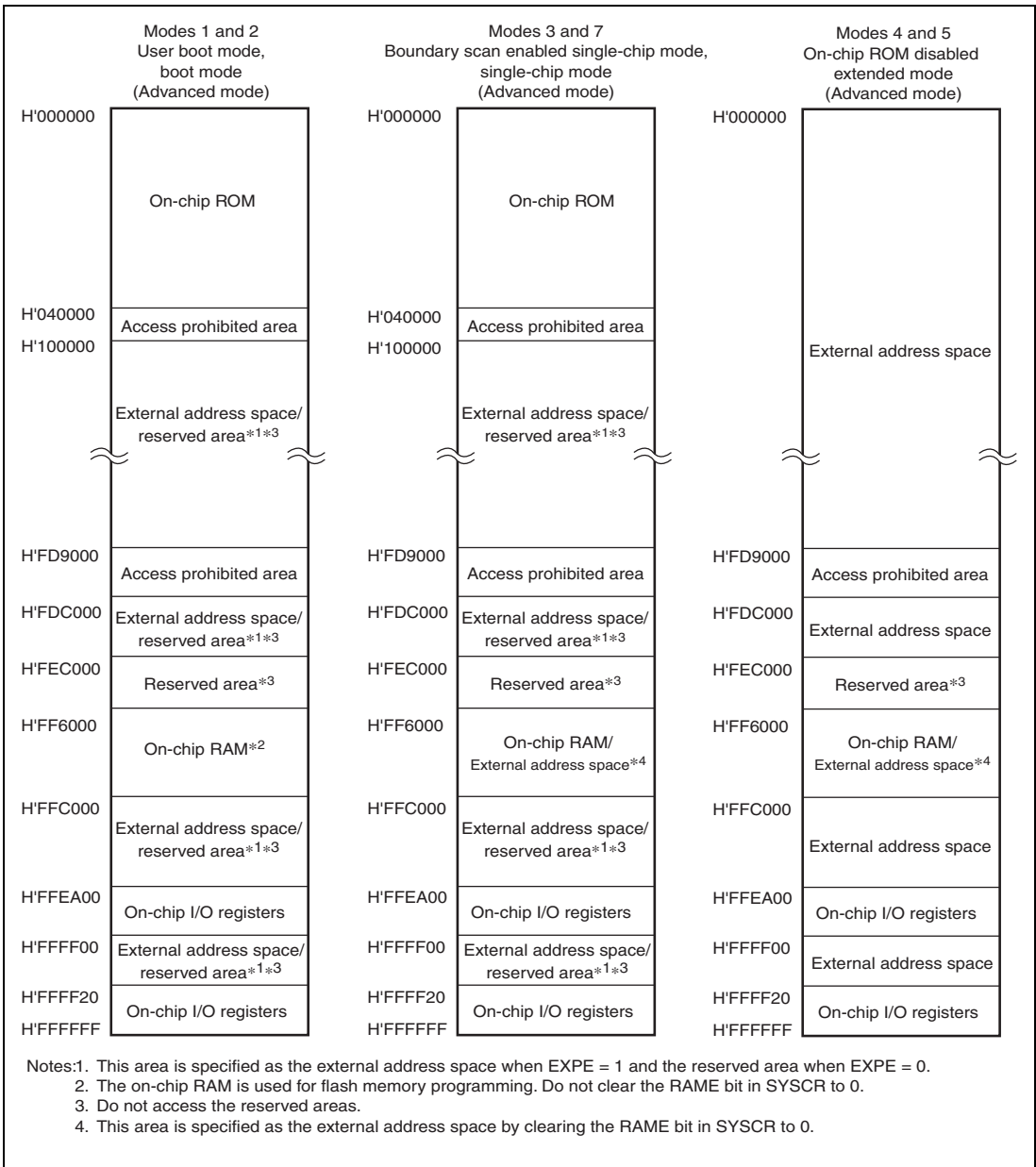
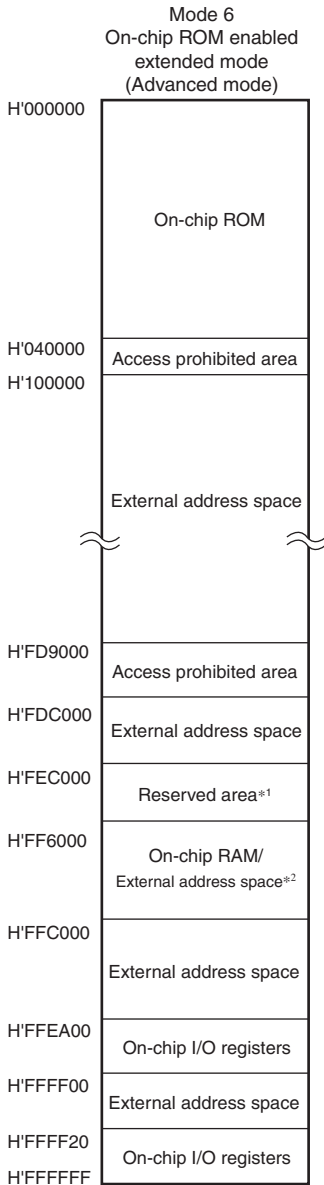

Figure 3.3 Address Map in Each Operating Mode of H8SX/1632 and H8SX/1632L (1)



- Notes: 1. Do not access the reserved area.
 2. This area is specified as the external address space by clearing the RAME bit in SYSCR to 0.

Figure 3.3 Address Map in Each Operating Mode of H8SX/1632 and H8SX/1632L (2)

Section 4 Resets

4.1 Types of Resets

There are five types of resets: a pin reset, power-on reset*, voltage-monitoring reset*, deep software standby reset, and watchdog timer reset. Table 4.1 shows the reset names and sources.

The internal state and pins are initialized by a reset. Figure 4.1 shows the reset targets to be initialized.

When using power-on reset* and voltage monitoring reset*, $\overline{\text{RES}}$ pin must be fixed high.

Table 4.1 Reset Names And Sources

Reset Name	Source
Pin reset	Voltage input to the $\overline{\text{RES}}$ pin is driven low.
Power-on reset*	Vcc rises or lowers
Voltage-monitoring reset*	Vcc falls (voltage detection: Vdet)
Deep software standby reset	Deep software standby mode is canceled by an interrupt.
Watchdog timer reset	The watchdog timer overflows.

Note: * Supported only by the H8SX/1638L Group.

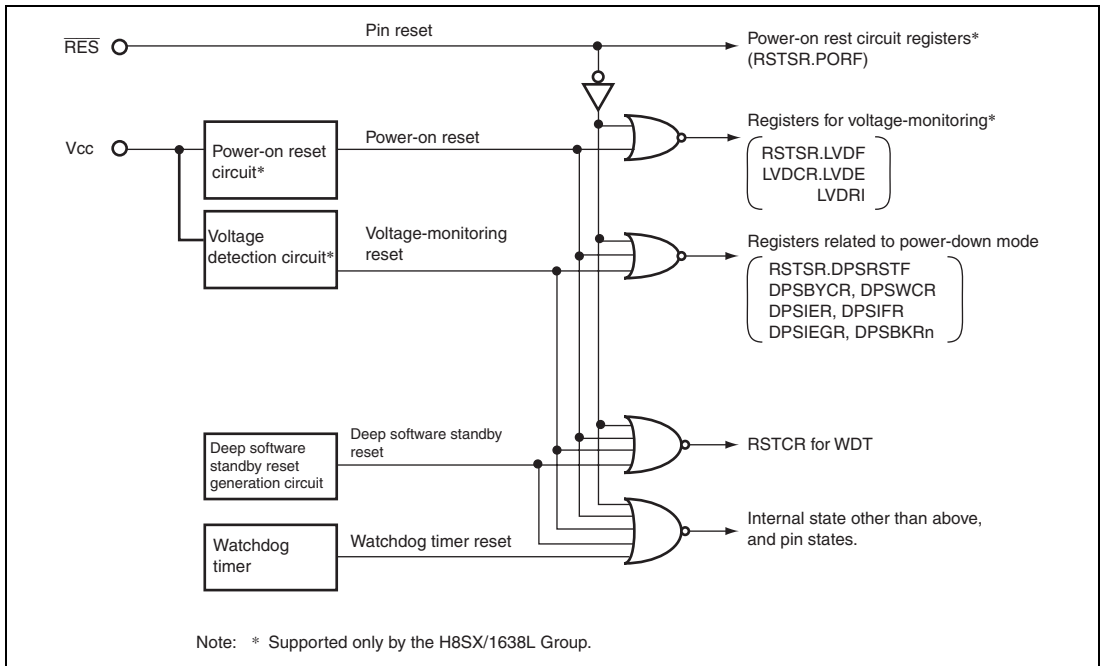

Figure 4.1 Block Diagram of Reset Circuit

Note that some registers are not initialized by any of the resets. The following describes the CPU internal registers.

The PC, one of the CPU internal registers, is initialized by loading the start address from vector addresses with the reset exception handling. At this time, the T bit in EXR is cleared to 0 and the I bits in EXR and CCR are set to 1. The general registers, MAC, and other bits in CCR are not initialized.

The initial value of the SP (ER7) is undefined. The SP should be initialized using the MOV.L instruction immediately after a reset. For details, see section 2, CPU. For other registers that are not initialized by a reset, see register descriptions in each section.

When a reset is canceled, the reset exception handling is started. For the reset exception handling, see section 6.3, Reset.

4.2 Input/Output Pin

Table 4.2 shows the pin related to resets.

Table 4.2 Pin Configuration

Pin Name	Symbol	I/O	Function
Reset	$\overline{\text{RES}}$	Input	Reset input

4.3 Register Descriptions

This LSI has the following registers for resets.

- Reset status register (RSTSR)
- Reset control/status register (RSTCSR)

4.3.1 Reset Status Register (RSTSR)

RSTSR indicates a source for generating an internal reset and voltage monitoring interrupt.

Bit	7	6	5	4	3	2	1	0
Bit name	DPSRSTF	—	—	—	—	LVDF*2	—	PORF*2
Initial value:	0	0	0	0	0	0*3	0*3	0*3
R/W:	R/(W)*1	R/W	R/W	R/W	R/W	R/W*4	R/W	R/W*5

- Note: 1. Only 0 can be written to clear the flag.
 2. Supported only by the H8SX/1638L Group.
 3. Initial value is undefined in the H8SX/1638L Group.
 4. Only 0 can be written to clear the flag in the H8SX/1638L Group.
 5. Only read is possible in the H8SX/1638L Group.

Bit	Bit Name	Initial Value	R/W	Description
7	DPSRSTF	0	R/(W)*1	<p>Deep Software Standby Reset Flag</p> <p>Indicates that deep software standby mode is canceled by an interrupt source specified with DPSIER or DPSIEGR and an internal reset is generated.</p> <p>[Setting condition]</p> <p>When deep software standby mode is canceled by an interrupt source.</p> <p>[Clearing conditions]</p> <ul style="list-style-type: none"> • When this bit is read as 1 and then written by 0. • When a pin reset, power-on reset*2, or voltage-monitoring reset*2 is generated.
6 to 3	—	All 0	R/W	<p>Reserved</p> <p>These bits are always read as 0. The write value should always be 0.</p>

- H8SX/1638 Group

Bit	Bit Name	Initial Value	R/W	Description
2 to 0	—	All 0	R/W	Reserved These bits are always read as 0. The write value should always be 0.

- H8SX/1638L Group

Bit	Bit Name	Initial Value	R/W	Description
2	LVDF	Undefined	R/(W)* ¹	LVD Flag This bit indicates that the voltage detection circuit has detected a low voltage (Vcc at or below Vdet). [Setting condition] Vcc falling to or below Vdet. [Clearing condition] <ul style="list-style-type: none"> After Vcc has exceeded Vdet and the specified stabilization period has elapsed, writing 0 to the bit after reading it as 1. Generation of a pin reset or power-on reset.
1	—	Undefined	R/W	Reserved The write value should always be 0.
0	PORF	Undefined	R	Power-on Reset Flag This bit indicates that a power-on reset has been generated. [Setting condition] Generation of a power-on reset [Clearing condition] Generation of a pin reset

Notes: 1. Only 0 can be written to clear the flag.
2. Supported only by the H8SX/1638L Group.

4.3.2 Reset Control/Status Register (RSTCSR)

RSTCSR controls an internal reset signal generated by the watchdog timer and selects the internal reset signal type. RSTCSR is initialized to H'1F by a pin reset or a deep software standby reset, but not by the internal reset signal generated by a WDT overflow.

Bit	7	6	5	4	3	2	1	0
Bit name	WOVF	RSTE	—	—	—	—	—	—
Initial value:	0	0	0	1	1	1	1	1
R/W:	R/(W)*	R/W	R/W	R	R	R	R	R

Note: * Only 0 can be written to clear the flag.

Bit	Bit Name	Initial Value	R/W	Description
7	WOVF	0	R/(W)*	<p>Watchdog Timer Overflow Flag</p> <p>This bit is set when TCNT overflows in watchdog timer mode, but not set in interval timer mode. Only 0 can be written to.</p> <p>[Setting condition]</p> <p>When TCNT overflows (H'FF → H'00) in watchdog timer mode.</p> <p>[Clearing condition]</p> <p>When this bit is read as 1 and then written by 0.</p> <p>(The flag must be read after writing of 0, when this bit is cleared by the CPU using an interrupt.)</p>
6	RSTE	0	R/W	<p>Reset Enable</p> <p>Selects whether or not the LSI internal state is reset by a TCNT overflow in watchdog timer mode.</p> <p>0: Internal state is not reset when TCNT overflows. (Although this LSI internal state is not reset, TCNT and TCSR of the WDT are reset.)</p> <p>1: Internal state is reset when TCNT overflows.</p>
5	—	0	R/W	<p>Reserved</p> <p>Although this bit is readable/writable, operation is not affected by this bit.</p>
4 to 0	—	1	R	<p>Reserved</p> <p>These are read-only bits but cannot be modified.</p>

Note: * Only 0 can be written to clear the flag.

4.4 Pin Reset

This is a reset generated by the $\overline{\text{RES}}$ pin.

When the $\overline{\text{RES}}$ pin is driven low, all the processing in progress is aborted and the LSI enters a reset state. In order to firmly reset the LSI, the $\overline{\text{STBY}}$ pin should be set to high and the $\overline{\text{RES}}$ pin should be held low at least for 20 ms at a power-on. During operation, the $\overline{\text{RES}}$ pin should be held low at least for 20 states.

4.5 Power-on Reset (POR) (H8SX/1638L Group)

This is an internal reset generated by the power-on reset circuit.

If RES is in the high-level state when power is supplied, a power-on reset is generated. After V_{cc} has exceeded V_{por} and the specified period (power-on reset time) has elapsed, the chip is released from the power-on reset state. The power-on reset time is a period for stabilization of the external power supply and the LSI circuit.

If $\overline{\text{RES}}$ is at the high-level when the power-supply voltage (V_{cc}) falls to or below V_{por} , a power-on reset is generated. The chip is released after V_{cc} has risen above V_{por} and the power-on reset time has elapsed.

After a power-on reset has been generated, the PORF bit in RSTSR is set to 1. The PORF bit is in a read-only register and is only initialized by a pin reset. Figure 4.2 shows the operation of a power-on reset.

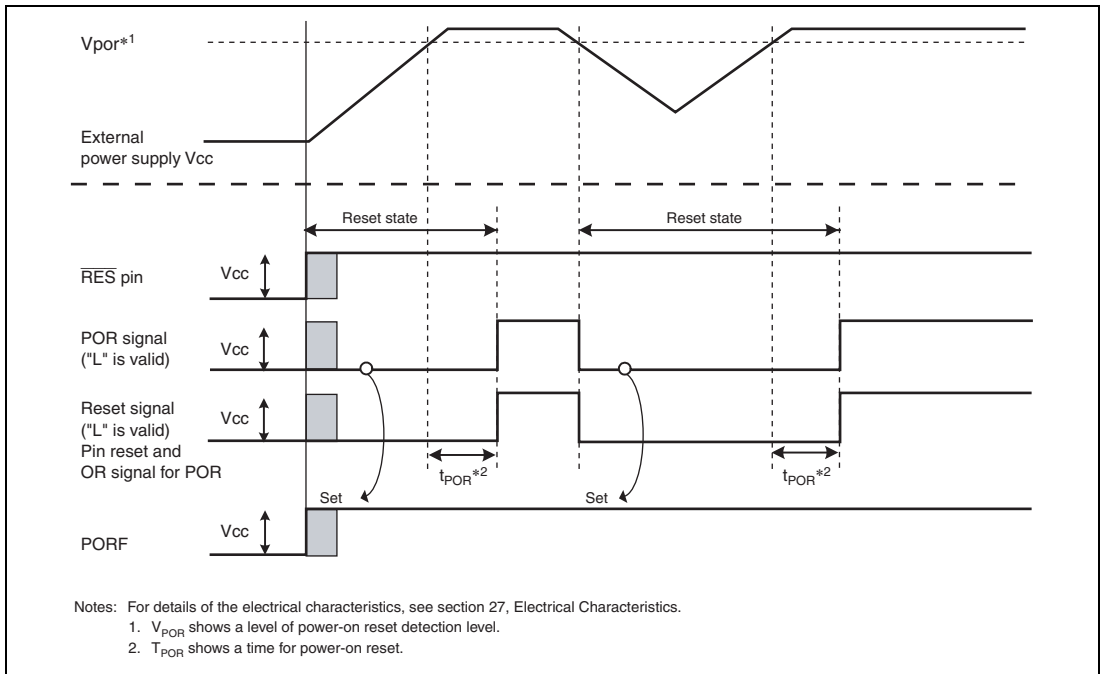

Figure 4.2 Operation of a Power on Reset

4.6 Power Supply Monitoring Reset (H8SX1638L Group)

This is an internal reset generated by the power-supply detection circuit.

When V_{cc} falls below V_{det} in the state where the LVDE bit in LVDCR has been set to 1 and the LVDR1 bit has been cleared to 0, a voltage-monitoring reset is generated. When V_{cc} subsequently rises above V_{det} , release from the voltage-monitoring reset proceeds after a specified time has elapsed.

For details of the voltage-monitoring reset, see section 5, Voltage Detection Circuit (LVD), and section 27, Electrical Characteristics.

4.7 Deep Software Standby Reset

This is an internal reset generated when deep software standby mode is canceled by an interrupt.

When deep software standby mode is canceled, a deep software standby reset is generated, and simultaneously, clock oscillation starts. After the time specified with DPSWCR has elapsed, the deep software standby reset is canceled.

For details of the deep software standby reset, see section 25, Power-Down Modes.

4.8 Watchdog Timer Reset

This is an internal reset generated by the watchdog timer.

When the RSTE bit in RSTCSR is set to 1, a watchdog timer reset is generated by a TCNT overflow. After a certain time, the watchdog timer reset is canceled.

For details of the watchdog timer reset, see section 16, Watchdog Timer (WDT).

4.9 Determination of Reset Generation Source

Reading RSTCSR, RSTSR, and LVDCR* of the voltage detection circuit determines which reset was used to execute the reset exception handling. Figure 4.2 shows an example of the flow to identify a reset generation source.

Note: * Supported only by the H8SX/1638L Group.

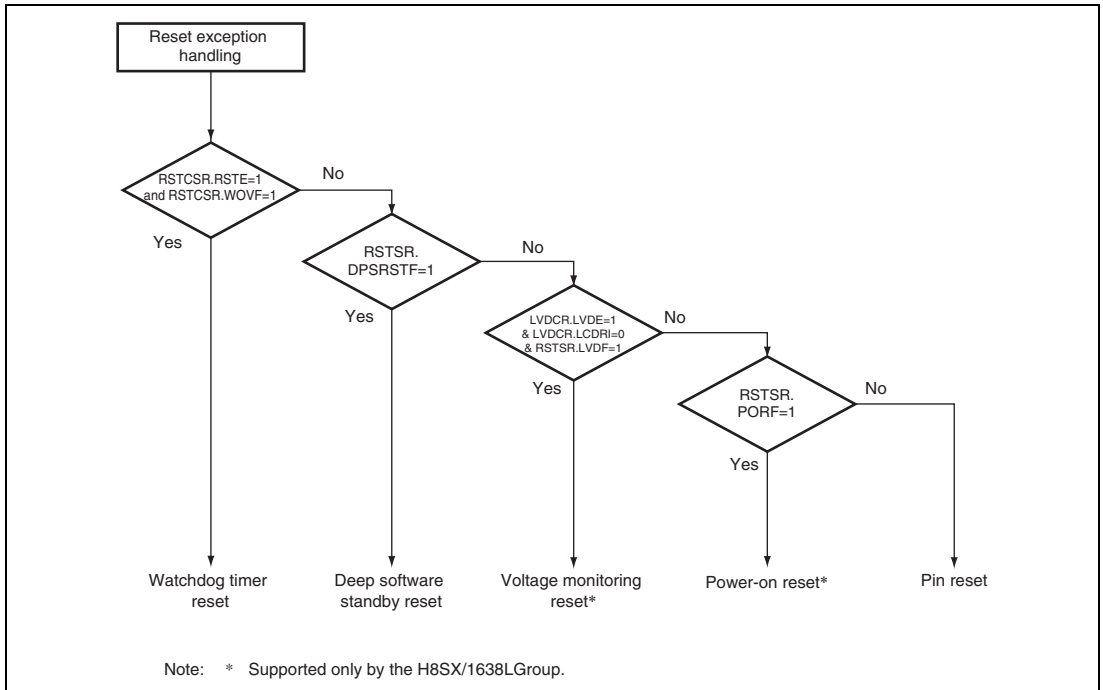

Figure 4.3 Example of Reset Generation Source Determination Flow

Section 5 Voltage Detection Circuit (LVD)

The voltage detection circuit (LVD) is only supported by the H8SX/1638L Group.

This circuit is used to monitor V_{cc} . The LVD is capable of internally resetting the LSI when V_{cc} falls and crosses the voltage detection level. An interrupt can also be generated.

5.1 Features

- Voltage-detection circuit

Capable of detecting the power-supply voltage (V_{cc}) becoming less than or equal to V_{det} .

Capable of generating an internal reset or interrupt when a low voltage is detected.

A block diagram of the voltage detection circuit is shown in figure 5.1.

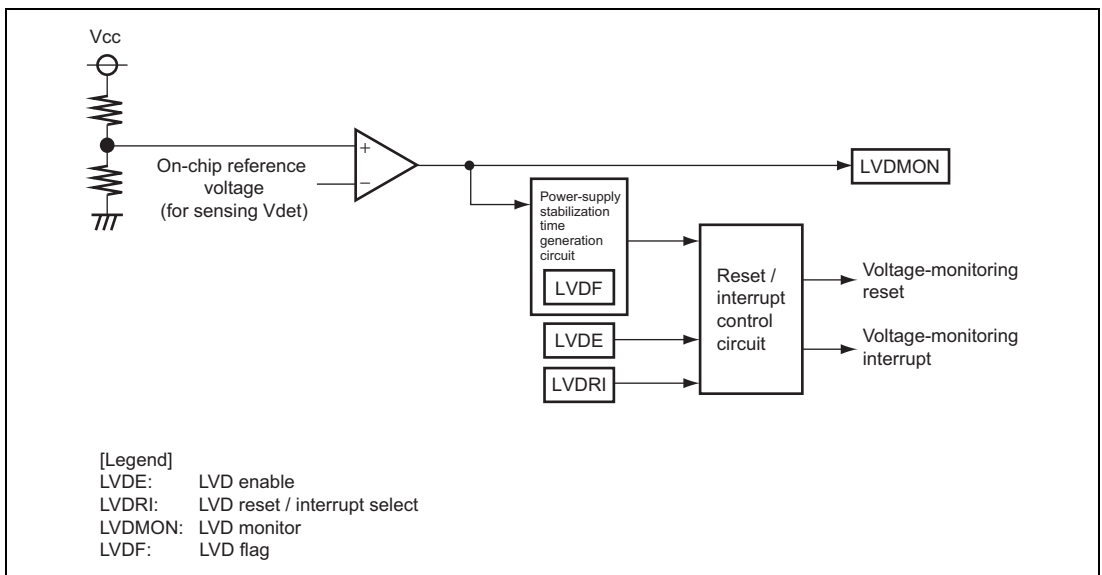

Figure 5.1 Block Diagram of Voltage-Detection Circuit

5.2 Register Descriptions

The registers of the voltage detection circuit are listed below.

- Voltage detection control register (LVDCR)
- Reset status register (RSTSR)

5.2.1 Voltage Detection Control Register (LVDCR)

The LVDCR controls the voltage-detection circuit.

LVDE, LVDRI, and LVDMON are initialized by a pin reset or power-on reset

Bit	7	6	5	4	3	2	1	0
Bit name	LVDE	LVDRI	—	LVDMON	—	—	—	—
Initial value:	0	0	0	0	0	0	0	0
R/W:	R/W	R/W	R/W	R	R/W	R/W	R/W	R/W

Bit	Bit Name	Initial Value	R/W	Description
7	LVDE	0	R/W	<p>LVD Enable</p> <p>This bit enables or disables issuing of a reset or interrupt by the voltage-detection circuit.</p> <p>0: Disabled</p> <p>1: Enabled</p>
6	LVDRI	0	R/W	<p>LVD Reset/Interrupt Select</p> <p>This bit selects whether an internal reset or interrupt is generated when the voltage detection circuit detects a low voltage. When modifying the LVDRI bit, ensure that low-voltage detection is in the disabled state (the LVDE bit is cleared to 0).</p> <p>0: A reset is generated when a voltage is detected.</p> <p>1: An interrupt is generated when a low voltage is detected.</p>
5	—	0	R/W	<p>Reserved</p> <p>This bit is always read as 0 and the write value should always be 0.</p>

Bit	Bit Name	Initial Value	R/W	Description
4	LVDMON	0	R	LVD Monitor This bit monitors the voltage level. This bit is valid when the LVDE bit is 1 and read as 0 when the LVDE bit is 0. Writing to this bit is ineffective. 0: Vcc must fall below Vdet. 1: Vcc must rise above Vdet.
3 to 0	—	0	R/W	Reserved These bits are always read as 0 and the write value should always be 0.

5.2.2 Reset Status Register (RSTSR)

RSTSR indicates the source of an internal reset or voltage monitoring interrupt.

Bit	7	6	5	4	3	2	1	0
Bit name	DPSRSTF	—	—	—	—	LVDF	—	PORF
Initial value:	0	0	0	0	0	Undefined	Undefined	Undefined
R/W:	R/(W)*	R/W	R/W	R/W	R/W	R/(W)*	R/W	R

Note: * To clear the flag, only 0 should be written to.

Bit	Bit Name	Initial Value	R/W	Description
7	DPSRSTF	0	R/W*	Deep Software Standby Reset Flag This bit indicates release from deep software standby mode due to the interrupt source selected by DPSIER and DPSIEGR, and generation of an internal reset. [Setting condition] Release from deep software standby mode due to an interrupt source. [Clearing condition] <ul style="list-style-type: none"> Writing 0 to the bit after reading it as 1. Generation of a pin reset, power on reset, or voltage monitoring reset.

Bit	Bit Name	Initial Value	R/W	Description
6 to 3	—	All 0	R/W	Reserved These bits are always read as 0 and the write value should always be 0.
2	LVDF	Undefined	R/(W)*	LVD Flag This bit indicates that the voltage detection circuit has detected a low voltage (V_{cc} at or below V_{det}). [Setting condition] V_{cc} falling to or below V_{det} . [Clearing condition] <ul style="list-style-type: none"> After V_{cc} has exceeded V_{det} and the specified stabilization period has elapsed, writing 0 to the bit after reading it as 1. Generation of a pin reset or power-on reset.
1	—	Undefined	R/W	Reserved The write value should always be 0.
0	PORF	Undefined	R	Power-on Reset Flag This bit indicates that a power-on reset has been generated. [Setting condition] Generation of a power-on reset [Clearing condition] Generation of a pin reset

Note: * To clear the flag, only 0 should be written to.

5.3 Voltage Detection Circuit

5.3.1 Voltage Monitoring Reset

Figure 5.2 shows the timing of a voltage monitoring reset by the voltage-detection circuit.

When V_{CC} falls below V_{det} in the state where the LVDE bit in LVDCR has been set to 1 and the LVDRI bit has been cleared to 0, the LVDF bit is set to 1 and the voltage-detection circuit generates a voltage monitoring reset.

Next, after V_{CC} has risen above V_{det} , release from the voltage-monitoring reset takes place after a period for stabilization (t_{por}) has elapsed. The period for stabilization (t_{por}) is a time that is generated by the voltage detection circuit in order to stabilize the V_{CC} and the internal circuit of the LSI.

When a voltage-monitoring reset is generated, the LVDF bit is set to 1.

For details, see section 27, Electrical Characteristics.

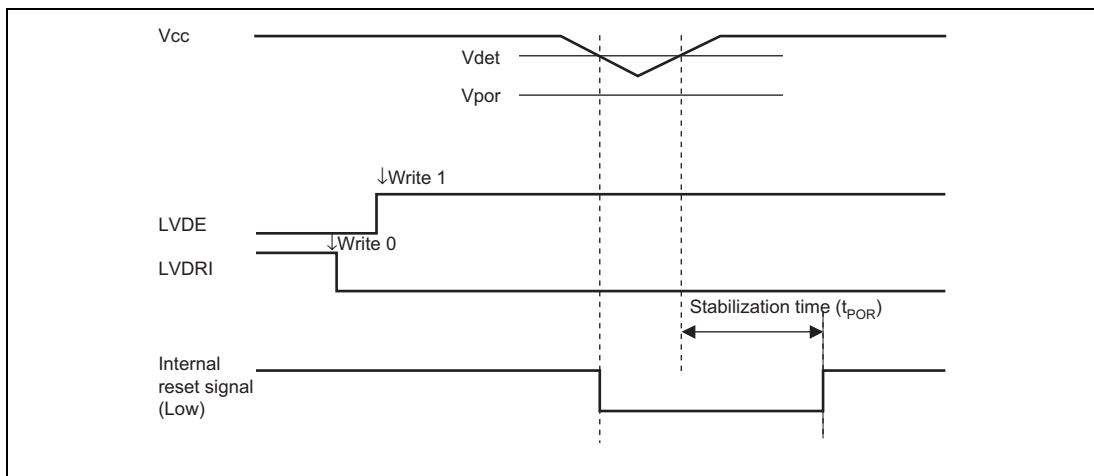

Figure 5.2 Timing of the Voltage-Monitoring Reset

5.3.2 Voltage Monitoring Interrupt

Figure 5.3 shows the timing of a voltage monitoring interrupt by the voltage-detection circuit.

When V_{cc} falls below the V_{det} in a state where the LVDE and LVDRI bits in LVDSCR are both set to 1, the LVDF bit is set to 1 and a voltage monitoring interrupt is requested.

The voltage monitoring interrupt signal is internally connected to $\overline{IRQ14-B}$, so the IRQ14F bit in the ISR is set to 1 when the interrupt is generated.

As for the IRQ14 setting, set both the ITS14 bit in PFCRB and the IRQ14E bit in the IER to 1, and the IRQ14SR and IRQ14SF bits in the ISCR to 01 (interrupt request on falling edge).

Figure 5.4 shows the procedure for setting the voltage-monitoring interrupt.

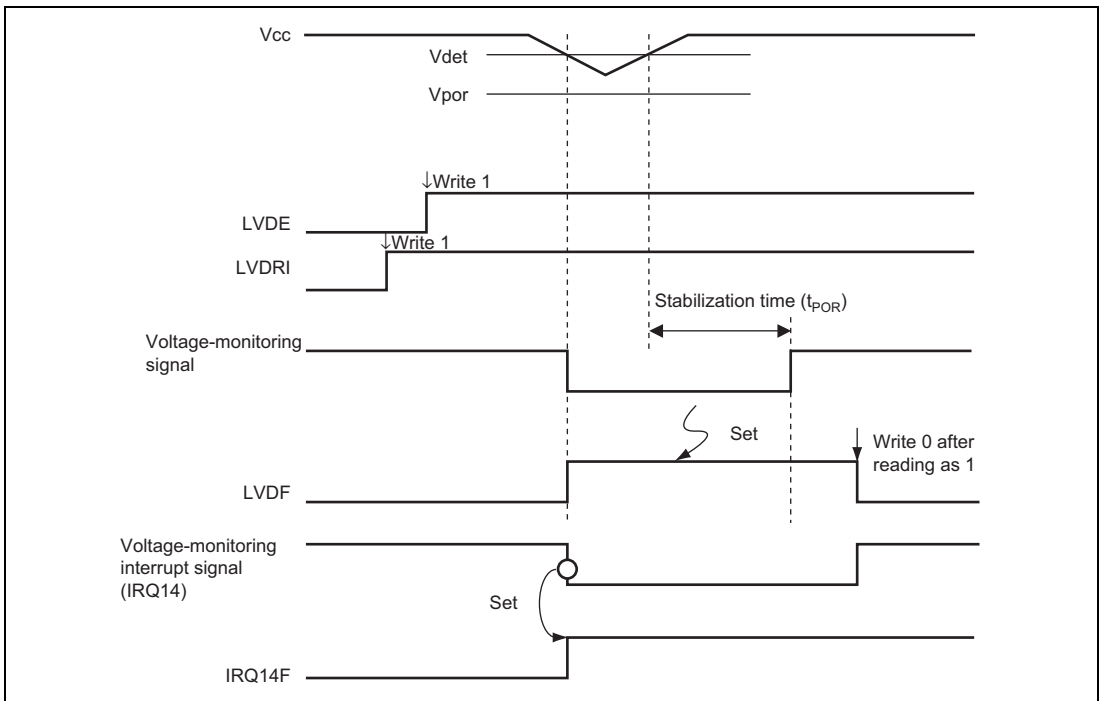

Figure 5.3 Timing of the Voltage-Monitoring Interrupt

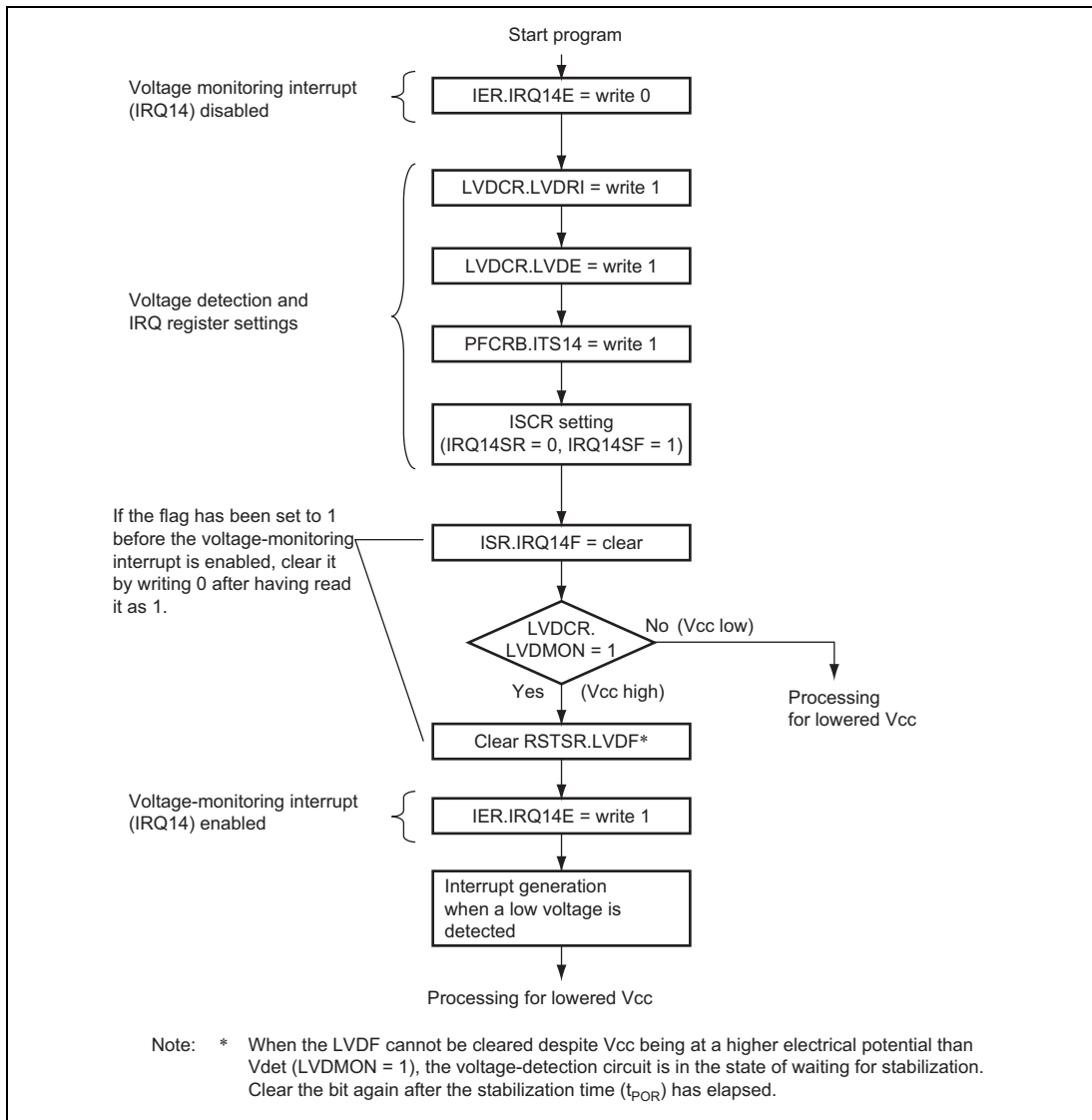

Figure 5.4 Example of the Procedure for Setting the Voltage-Monitoring Interrupt

5.3.3 Release from Deep Software Standby Mode by the Voltage-Detection Circuit

If the LVDE and LVDRI bits in LVDCR and the DLVDIE bit in DPSIER have all been set to 1 during a period in deep software standby mode, the voltage-detection circuit requests release from deep software standby mode when V_{cc} falls to or below V_{det} . This sets the DLVDIF bit in DPSIFR to 1, thus producing release from the deep software standby mode. For the deep software standby mode, see section 25, Power-Down Modes.

5.3.4 Voltage Monitor

The result of voltage detection by the voltage-detection circuit can be monitored by checking the value of the LVDMON bit in LVDCR. When the LVDMON bit has been enabled by setting the LVDE bit, 0 indicates that V_{cc} is at or below V_{det} and 1 indicates that V_{cc} is above V_{det} . This bit should be read while the voltage-monitoring reset has been disabled by setting the LVDRI bit to 1.

Before clearing the LVDF bit in RSTSR to 0, confirm that the LVDMON bit is set to 1 (indicating that V_{cc} is above V_{det}). When it is impossible to clear the LVDF bit despite the LVDMON bit being 1, the voltage-detection circuit is in the state of waiting for stabilization. In such cases, clear the bit again after the stabilization time (t_{por}) has elapsed.

Section 6 Exception Handling

6.1 Exception Handling Types and Priority

As table 6.1 indicates, exception handling is caused by a reset, a trace, an address error, an interrupt, a trap instruction, a sleep instruction, and an illegal instruction (general illegal instruction or slot illegal instruction). Exception handling is prioritized as shown in table 6.1. If two or more exceptions occur simultaneously, they are accepted and processed in order of priority. Exception sources, the stack structure, and operation of the CPU vary depending on the interrupt control mode. For details on the interrupt control mode, see section 7, Interrupt Controller.

Table 6.1 Exception Types and Priority

Priority	Exception Type	Exception Handling Start Timing
High  Low	Reset	Exception handling starts at the timing of level change from low to high on the $\overline{\text{RES}}$ pin, or when the watchdog timer overflows. The CPU enters the reset state when the $\overline{\text{RES}}$ pin is low.
	Illegal instruction	Exception handling starts when an undefined code is executed.
	Trace* ¹	Exception handling starts after execution of the current instruction or exception handling, if the trace (T) bit in EXR is set to 1.
	Address error	After an address error has occurred, exception handling starts on completion of instruction execution.
	Interrupt	Exception handling starts after execution of the current instruction or exception handling, if an interrupt request has occurred.* ²
	Sleep instruction	Exception handling starts by execution of a sleep instruction (SLEEP), if the SSBY bit in SBYCR is set to 0 and the SLPIE bit in SBYCR is set to 1.
	Trap instruction* ³	Exception handling starts by execution of a trap instruction (TRAPA).

- Notes: 1. Traces are enabled only in interrupt control mode 2. Trace exception handling is not executed after execution of an RTE instruction.
2. Interrupt detection is not performed on completion of ANDC, ORC, XORC, or LDC instruction execution, or on completion of reset exception handling.
3. Trap instruction exception handling requests and sleep instruction exception handling requests are accepted at all times in program execution state.

6.2 Exception Sources and Exception Handling Vector Table

Different vector table address offsets are assigned to different exception sources. The vector table addresses are calculated from the contents of the vector base register (VBR) and vector table address offset of the vector number. The start address of the exception service routine is fetched from the exception handling vector table indicated by this vector table address.

Table 6.2 shows the correspondence between the exception sources and vector table address offsets. Table 6.3 shows the calculation method of exception handling vector table addresses.

Table 6.2 Exception Handling Vector Table

Exception Source	Vector Number	Vector Table Address Offset* ¹		
		Normal Mode* ²	Advanced, Middle* ² , Maximum* ² Modes	
Reset	0	H'0000 to H'0001	H'0000 to H'0003	
Reserved for system use	1	H'0002 to H'0003	H'0004 to H'0007	
	2	H'0004 to H'0005	H'0008 to H'000B	
	3	H'0006 to H'0007	H'000C to H'000F	
Illegal instruction	4	H'0008 to H'0009	H'0010 to H'0013	
Trace	5	H'000A to H'000B	H'0014 to H'0017	
Reserved for system use	6	H'000C to H'000D	H'0018 to H'001B	
Interrupt (NMI)	7	H'000E to H'000F	H'001C to H'001F	
Trap instruction (#0)	8	H'0010 to H'0011	H'0020 to H'0023	
	(#1)	9	H'0012 to H'0013	H'0024 to H'0027
	(#2)	10	H'0014 to H'0015	H'0028 to H'002B
	(#3)	11	H'0016 to H'0017	H'002C to H'002F
CPU address error	12	H'0018 to H'0019	H'0030 to H'0033	
DMA address error* ³	13	H'001A to H'001B	H'0034 to H'0037	
UBC break interrupt	14	H'001C to H'001D	H'0038 to H'003B	
Reserved for system use	15	H'001E to H'001F	H'003C to H'003F	
	17	H'0022 to H'0023	H'0044 to H'0047	
Sleep interrupt	18	H'0024 to H'0025	H'0048 to H'004B	

Exception Source	Vector Number	Vector Table Address Offset* ¹		
		Normal Mode* ²	Advanced, Middle* ² , Maximum* ² Modes	
Reserved for system use	19	H'0026 to H'0027	H'004C to H'004F	
	23	H'002E to H'002F	H'005C to H'005F	
User area (not used)	24	H'0030 to H'0031	H'0060 to H'0063	
	63	H'007E to H'007F	H'00FC to H'00FF	
External interrupt	IRQ0	64	H'0080 to H'0081	H'0100 to H'0103
	IRQ1	65	H'0082 to H'0083	H'0104 to H'0107
	IRQ2	66	H'0084 to H'0085	H'0108 to H'010B
	IRQ3	67	H'0086 to H'0087	H'010C to H'010F
	IRQ4	68	H'0088 to H'0089	H'0110 to H'0113
	IRQ5	69	H'008A to H'008B	H'0114 to H'0117
	IRQ6	70	H'008C to H'008D	H'0118 to H'011B
	IRQ7	71	H'008E to H'008F	H'011C to H'011F
	IRQ8	72	H'0090 to H'0091	H'0120 to H'0123
	IRQ9	73	H'0092 to H'0093	H'0124 to H'0127
	IRQ10	74	H'0094 to H'0095	H'0128 to H'012B
	IRQ11	75	H'0096 to H'0097	H'012C to H'012F
	IRQ12	76	H'0098 to H'0099	H'0130 to H'0133
	IRQ13	77	H'009A to H'009B	H'0134 to H'0137
	IRQ14	78	H'009C to H'009D	H'0138 to H'013B
Internal interrupt* ⁴	80	H'00A0 to H'00A1	H'0140 to H'0143	
	255	H'01FE to H'01FF	H'03FC to H'03FF	

Notes: 1. Lower 16 bits of the address.

2. Not available in this LSI.

3. A DMA address error is generated by the DTC and DMAC.

4. For details of internal interrupt vectors, see section 7.5, Interrupt Exception Handling Vector Table.

Table 6.3 Calculation Method of Exception Handling Vector Table Address

Exception Source	Calculation Method of Vector Table Address
Reset, CPU address error	Vector table address = (vector table address offset)
Other than above	Vector table address = VBR + (vector table address offset)

[Legend]

VBR: Vector base register

Vector table address offset: See table 6.2.

6.3 Reset

A reset has priority over any other exception. When the $\overline{\text{RES}}$ pin goes low, all processing halts and this LSI enters the reset state. To ensure that this LSI is reset, hold the $\overline{\text{RES}}$ pin low for at least 20 ms with the STBY pin driven high when the power is turned on. When operation is in progress, hold the $\overline{\text{RES}}$ pin low for at least 20 cycles.

The chip can also be reset by overflow of the watchdog timer. For details, see section 16, Watchdog Timer (WDT).

A reset initializes the internal state of the CPU and the registers of the on-chip peripheral modules. The interrupt control mode is 0 immediately after a reset.

6.3.1 Reset Exception Handling

When the $\overline{\text{RES}}$ pin goes high after being held low for the necessary time, this LSI starts reset exception handling as follows:

1. The internal state of the CPU and the registers of the on-chip peripheral modules are initialized, VBR is cleared to H'00000000, the T bit is cleared to 0 in EXR, and the I bits are set to 1 in EXR and CCR.
2. The reset exception handling vector address is read and transferred to the PC, and program execution starts from the address indicated by the PC.

Figures 6.1 and 6.2 show examples of the reset sequence.

6.3.2 Interrupts after Reset

If an interrupt is accepted after a reset but before the stack pointer (SP) is initialized, the PC and CCR will not be saved correctly, leading to a program crash. To prevent this, all interrupt requests, including NMI, are disabled immediately after a reset. Since the first instruction of a program is always executed immediately after the reset state ends, make sure that this instruction initializes the stack pointer (example: `MOV.L #xx: 32, SP`).

6.3.3 On-Chip Peripheral Functions after Reset Release

After the reset state is released, MSTPCRA and MSTPCRB are initialized to H'0FFF and H'FFFF, respectively, and all modules except the DTC and DMAC enter the module stop state.

Consequently, on-chip peripheral module registers cannot be read or written to. Register reading and writing is enabled when the module stop state is canceled.

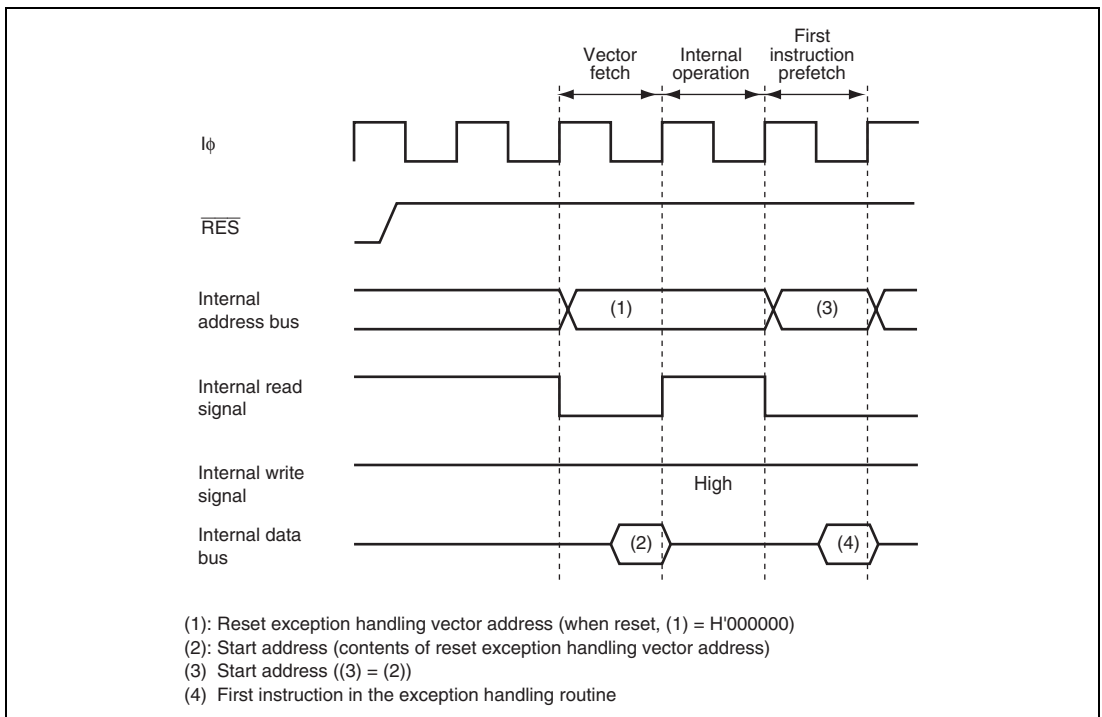

Figure 6.1 Reset Sequence (On-chip ROM Enabled Advanced Mode)

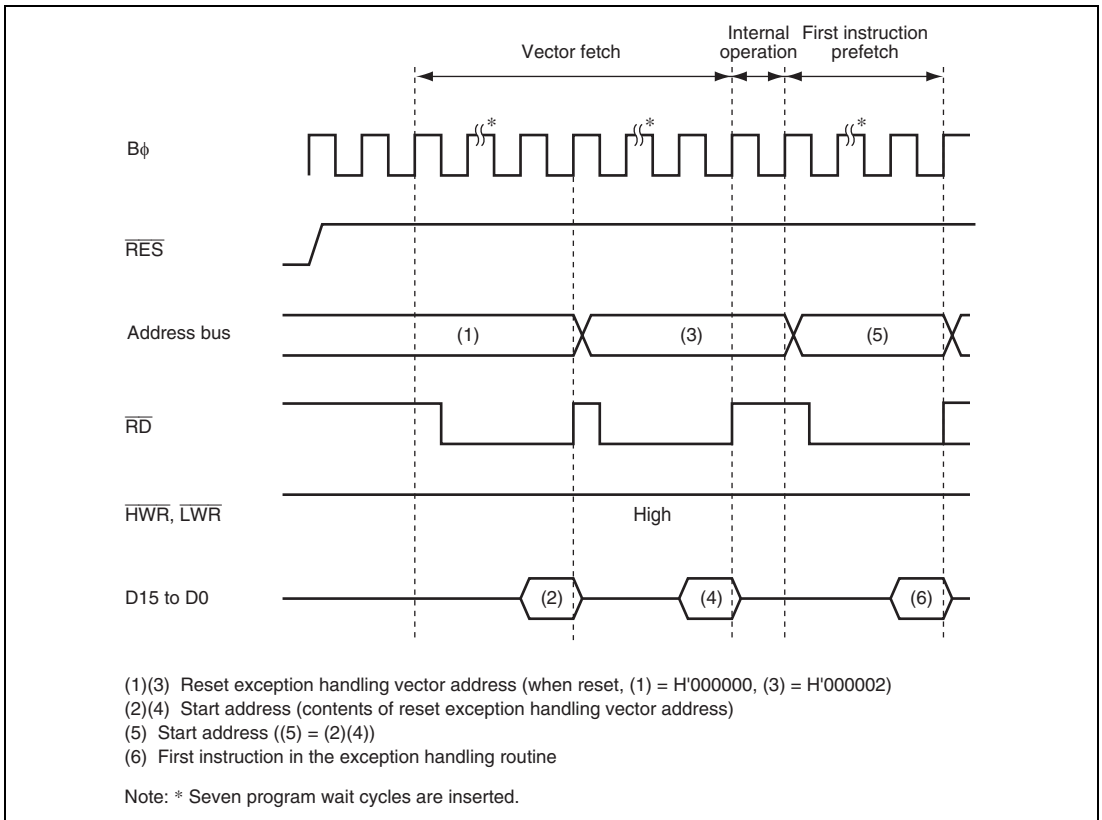

Figure 6.2 Reset Sequence
(16-Bit External Access in On-chip ROM Disabled Advanced Mode)

6.4 Traces

Traces are enabled in interrupt control mode 2. Trace mode is not activated in interrupt control mode 0, irrespective of the state of the T bit. Before changing interrupt control modes, the T bit must be cleared. For details on interrupt control modes, see section 7, Interrupt Controller.

If the T bit in EXR is set to 1, trace mode is activated. In trace mode, a trace exception occurs on completion of each instruction. Trace mode is not affected by interrupt masking by CCR. Table 6.4 shows the state of CCR and EXR after execution of trace exception handling. Trace mode is canceled by clearing the T bit in EXR to 0 during the trace exception handling. However, the T bit saved on the stack retains its value of 1, and when control is returned from the trace exception handling routine by the RTE instruction, trace mode resumes. Trace exception handling is not carried out after execution of the RTE instruction.

Interrupts are accepted even within the trace exception handling routine.

Table 6.4 Status of CCR and EXR after Trace Exception Handling

Interrupt Control Mode	CCR			EXR
	I	UI	T	I2 to I0
0	Trace exception handling cannot be used.			
2	1	—	0	—

[Legend]

- 1: Set to 1
- 0: Cleared to 0
- : Retains the previous value.

6.5 Address Error

6.5.1 Address Error Source

Instruction fetch, stack operation, or data read/write shown in table 6.5 may cause an address error.

Table 6.5 Bus Cycle and Address Error

Bus Cycle			
Type	Bus Master	Description	Address Error
Instruction fetch	CPU	Fetches instructions from even addresses	No (normal)
		Fetches instructions from odd addresses	Occurs
		Fetches instructions from areas other than on-chip peripheral module space* ¹	No (normal)
		Fetches instructions from on-chip peripheral module space* ¹	Occurs
		Fetches instructions from external memory space in single-chip mode	Occurs
		Fetches instructions from access prohibited area.* ²	Occurs
Stack operation	CPU	Accesses stack when the stack pointer value is even address	No (normal)
		Accesses stack when the stack pointer value is odd	Occurs
Data read/write	CPU	Accesses word data from even addresses	No (normal)
		Accesses word data from odd addresses	No (normal)
		Accesses external memory space in single-chip mode	Occurs
		Accesses to access prohibited area.* ²	Occurs
Data read/write	DTC or DMAC	Accesses word data from even addresses	No (normal)
		Accesses word data from odd addresses	No (normal)
		Accesses external memory space in single-chip mode	Occurs
		Accesses to access prohibited area.* ²	Occurs
Single address transfer	DMAC	Address access space is the external memory space for single address transfer	No (normal)
		Address access space is not the external memory space for single address transfer	Occurs

Notes: 1. For on-chip peripheral module space, see section 9, Bus Controller (BSC).

2. For the access-prohibited area, refer to figure 3.1 in section 3.4, Address Map.

6.5.2 Address Error Exception Handling

When an address error occurs, address error exception handling starts after the bus cycle causing the address error ends and current instruction execution completes. The address error exception handling is as follows:

1. The contents of PC, CCR, and EXR are saved in the stack.
2. The interrupt mask bit is updated and the T bit is cleared to 0.
3. An exception handling vector table address corresponding to the address error is generated, the start address of the exception service routine is loaded from the vector table to PC, and program execution starts from that address.

Even though an address error occurs during a transition to an address error exception handling, the address error is not accepted. This prevents an address error from occurring due to stacking for exception handling, thereby preventing infinitive stacking.

If the SP contents are not a multiple of 2 when an address error exception handling occurs, the stacked values (PC, CCR, and EXR) are undefined.

When an address error occurs, the following is performed to halt the DTC and DMAC.

- The ERR bit of DTCCR in the DTC is set to 1.
- The ERRF bit of DMDR_0 in the DMAC is set to 1.
- The DTE bits of DMDRs for all channels in the DMAC are cleared to 0 to forcibly terminate transfer.

Table 6.6 shows the state of CCR and EXR after execution of the address error exception handling.

Table 6.6 Status of CCR and EXR after Address Error Exception Handling

Interrupt Control Mode	CCR			EXR
	I	UI	T	I2 to I0
0	1	—	—	—
2	1	—	0	7

[Legend]

- 1: Set to 1
- 0: Cleared to 0
- : Retains the previous value.

6.6 Interrupts

6.6.1 Interrupt Sources

Interrupt sources are NMI, UBC break interrupt, IRQ0 to IRQ11, and on-chip peripheral modules, as shown in table 6.7.

Table 6.7 Interrupt Sources

Type	Source	Number of Sources
NMI	NMI pin (external input)	1
UBC break interrupt	User break controller (UBC)	1
IRQ0 to IRQ15	Pins $\overline{\text{IRQ0}}$ to $\overline{\text{IRQ15}}$ (external input)	16
Voltage detection circuit*	Voltage detection circuit (LVD)	1
On-chip peripheral module	DMA controller (DMAC)	8
	Watchdog timer (WDT)	1
	A/D converter	2
	16-bit timer pulse unit (TPU)	52
	8-bit timer (TMR)	16
	Serial communications interface (SCI)	28
	I ² C bus interface 2 (IIC2)	2

Different vector numbers and vector table offsets are assigned to different interrupt sources. For vector number and vector table offset, refer to table 7.2, Interrupt Sources, Vector Address Offsets, and Interrupt Priority in section 7, Interrupt Controller.

Note: * Supported only by the H8SX/1638L Group.

6.6.2 Interrupt Exception Handling

Interrupts are controlled by the interrupt controller. The interrupt controller has two interrupt control modes and can assign interrupts other than NMI to eight priority/mask levels to enable multiple-interrupt control. The source to start interrupt exception handling and the vector address differ depending on the product. For details, refer to section 7, Interrupt Controller.

The interrupt exception handling is as follows:

1. The contents of PC, CCR, and EXR are saved in the stack.
2. The interrupt mask bit is updated and the T bit is cleared to 0.
3. An exception handling vector table address corresponding to the interrupt source is generated, the start address of the exception service routine is loaded from the vector table to PC, and program execution starts from that address.

6.7 Instruction Exception Handling

There are three instructions that cause exception handling: trap instruction, sleep instruction, and illegal instruction.

6.7.1 Trap Instruction

Trap instruction exception handling starts when a TRAPA instruction is executed. Trap instruction exception handling can be executed at all times in the program execution state. The trap instruction exception handling is as follows:

1. The contents of PC, CCR, and EXR are saved in the stack.
2. The interrupt mask bit is updated and the T bit is cleared to 0.
3. An exception handling vector table address corresponding to the vector number specified in the TRAPA instruction is generated, the start address of the exception service routine is loaded from the vector table to PC, and program execution starts from that address.

A start address is read from the vector table corresponding to a vector number from 0 to 3, as specified in the instruction code.

Table 6.8 shows the state of CCR and EXR after execution of trap instruction exception handling.

Table 6.8 Status of CCR and EXR after Trap Instruction Exception Handling

Interrupt Control Mode	CCR		EXR	
	I	UI	T	I2 to I0
0	1	—	—	—
2	1	—	0	—

[Legend]

1: Set to 1

0: Cleared to 0

—: Retains the previous value.

6.7.2 Sleep Instruction Exception Handling

The sleep instruction exception handling starts when a sleep instruction is executed with the SSBY bit in SBYCR set to 0 and the SLPIE bit in SBYCR set to 1. The sleep instruction exception handling can always be executed in the program execution state. In the exception handling, the CPU operates as follows.

1. The contents of PC, CCR, and EXR are saved in the stack.
2. The interrupt mask bit is updated and the T bit is cleared to 0.
3. An exception handling vector table address corresponding to the vector number specified in the SLEEP instruction is generated, the start address of the exception service routine is loaded from the vector table to PC, and program execution starts from that address.

Bus masters other than the CPU may gain the bus mastership after a sleep instruction has been executed. In such cases the sleep instruction will be started when the transactions of a bus master other than the CPU has been completed and the CPU has gained the bus mastership.

Table 6.9 shows the state of CCR and EXR after execution of sleep instruction exception handling. For details, see section 25.10, Sleep Instruction Exception Handling.

Table 6.9 Status of CCR and EXR after Sleep Instruction Exception Handling

Interrupt Control Mode	CCR		EXR	
	I	UI	T	I2 to I0
0	1	—	—	—
2	1	—	0	7

[Legend]

- 1: Set to 1
- 0: Cleared to 0
- : Retains the previous value.

6.7.3 Exception Handling by Illegal Instruction

The illegal instructions are general illegal instructions and slot illegal instructions. The exception handling by the general illegal instruction starts when an undefined code is executed. The exception handling by the slot illegal instruction starts when a particular instruction (e.g. its code length is two words or more, or it changes the PC contents) at a delay slot (immediately after a delayed branch instruction) is executed. The exception handling by the general illegal instruction and slot illegal instruction is always executable in the program execution state.

The exception handling is as follows:

1. The contents of PC, CCR, and EXR are saved in the stack.
2. The interrupt mask bit is updated and the T bit is cleared to 0.
3. An exception handling vector table address corresponding to the occurred exception is generated, the start address of the exception service routine is loaded from the vector table to PC, and program execution starts from that address.

Table 6.10 shows the state of CCR and EXR after execution of illegal instruction exception handling.

Table 6.10 Status of CCR and EXR after Illegal Instruction Exception Handling

Interrupt Control Mode	CCR		EXR	
	I	UI	T	I2 to I0
0	1	—	—	—
2	1	—	0	—

[Legend]

1: Set to 1

0: Cleared to 0

—: Retains the previous value.

6.8 Stack Status after Exception Handling

Figure 6.3 shows the stack after completion of exception handling.

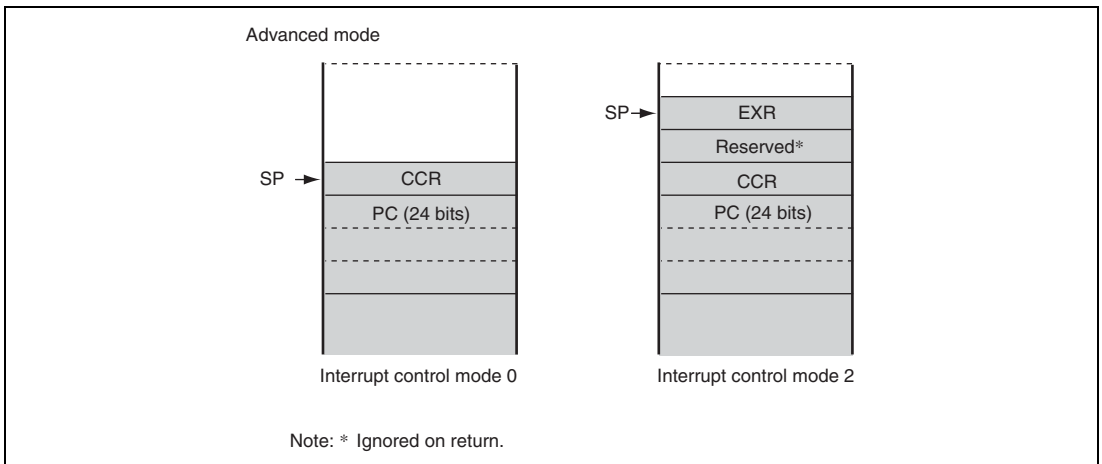
**Figure 6.3 Stack Status after Exception Handling**

6.9 Usage Note

When performing stack-manipulating access, this LSI assumes that the lowest address bit is 0. The stack should always be accessed by a word transfer instruction or a longword transfer instruction, and the value of the stack pointer (SP: ER7) should always be kept even. Use the following instructions to save registers:

```
PUSH.W   Rn      (or MOV.W Rn, @-SP)
PUSH.L   ERn     (or MOV.L ERn, @-SP)
```

Use the following instructions to restore registers:

```
POP.W    Rn      (or MOV.W @SP+, Rn)
POP.L    ERn     (or MOV.L @SP+, ERn)
```

Performing stack manipulation while SP is set to an odd value leads to an address error. Figure 6.4 shows an example of operation when the SP value is odd.

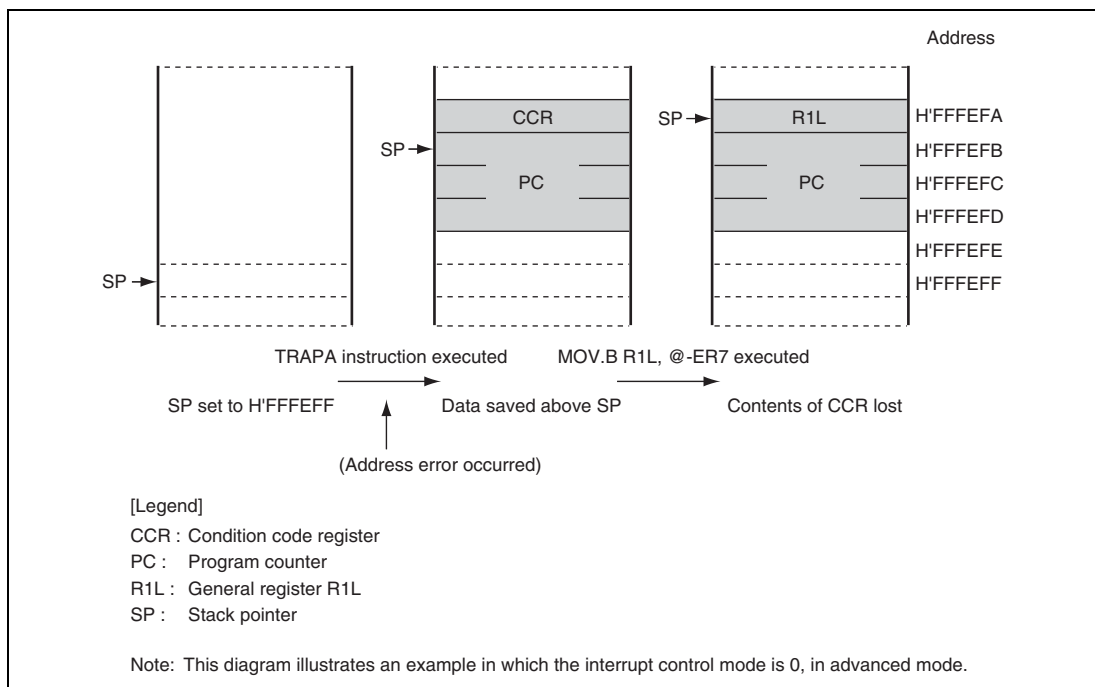

Figure 6.4 Operation when SP Value is Odd

Section 7 Interrupt Controller

7.1 Features

- Two interrupt control modes

Any of two interrupt control modes can be set by means of bits INTM1 and INTM0 in the interrupt control register (INTCR).
- Priority can be assigned by the interrupt priority register (IPR)

IPR provides for setting interrupt priority. Eight levels can be set for each module for all interrupts except for the interrupt requests listed below. The following eight interrupt requests are given priority of 8, therefore they are accepted at all times.

 - NMI
 - Illegal instructions
 - Trace
 - Trap instructions
 - CPU address error
 - DMA address error (occurred in the DTC and DMAC)
 - Sleep instruction
 - UBC break interrupt
- Independent vector addresses

All interrupt sources are assigned independent vector addresses, making it unnecessary for the source to be identified in the interrupt handling routine.
- Seventeen external interrupts

NMI is the highest-priority interrupt, and is accepted at all times. Rising edge or falling edge detection can be selected for NMI. Falling edge, rising edge, or both edge detection, or level sensing, can be selected for $\overline{\text{IRQ15}}$ to $\overline{\text{IRQ0}}$.
- DTC and DMAC control

DTC and DMAC can be activated by means of interrupts.
- CPU priority control function

The priority levels can be assigned to the CPU, DTC, and DMAC. The priority level of the CPU can be automatically assigned on an exception generation. Priority can be given to the CPU interrupt exception handling over that of the DTC and DMAC transfer.

A block diagram of the interrupt controller is shown in figure 7.1.

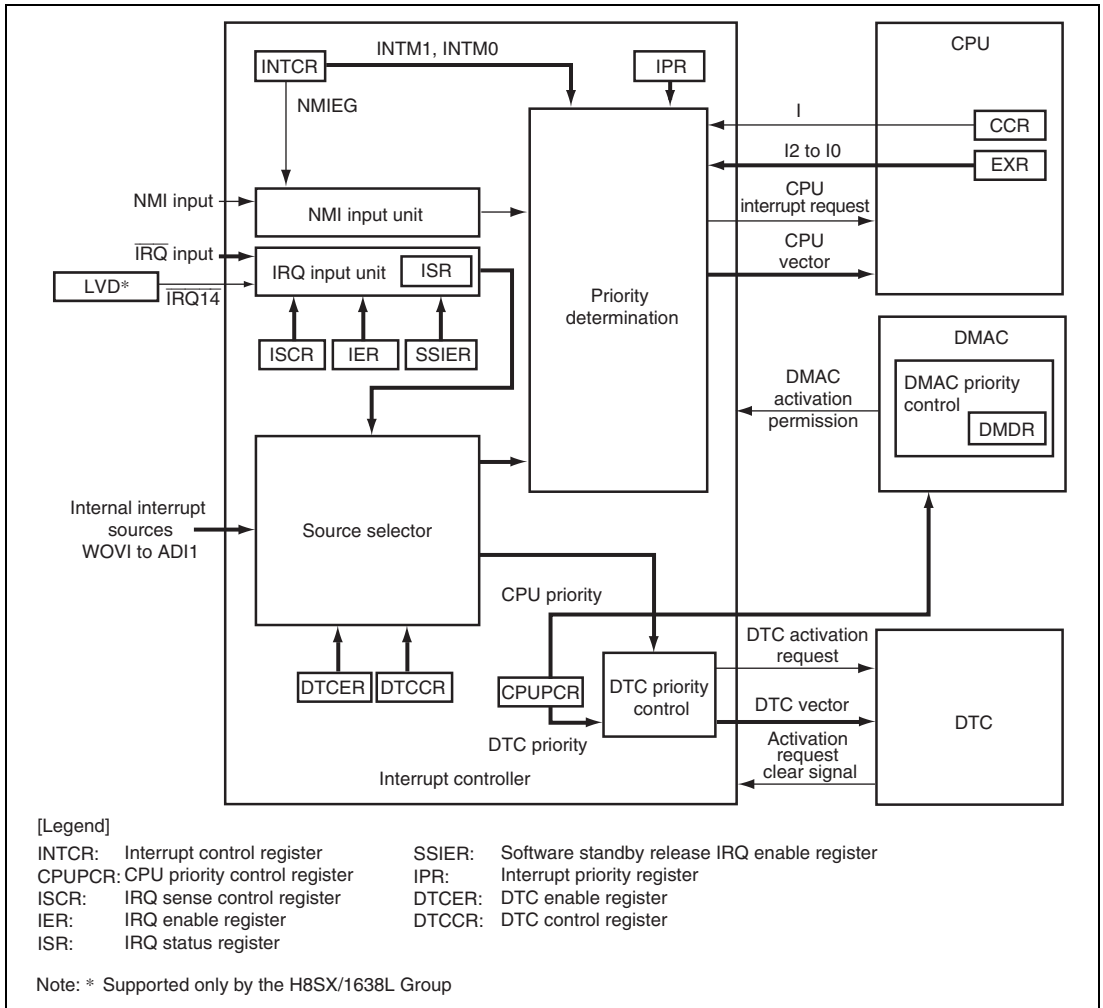

Figure 7.1 Block Diagram of Interrupt Controller

7.2 Input/Output Pins

Table 7.1 shows the pin configuration of the interrupt controller.

Table 7.1 Pin Configuration

Name	I/O	Function
NMI	Input	Nonmaskable External Interrupt Rising or falling edge can be selected.
IRQ15 to IRQ0	Input	Maskable External Interrupts Rising, falling, or both edges, or level sensing, can be independently selected.

7.3 Register Descriptions

The interrupt controller has the following registers.

- Interrupt control register (INTCR)
- CPU priority control register (CPUPCR)
- Interrupt priority registers A to I, K to O, Q, and R (IPRA to IPRI, IPRK to IPRO, IPRQ, and IPRR)
- IRQ enable register (IER)
- IRQ sense control registers H and L (ISCRH, ISCRL)
- IRQ status register (ISR)
- Software standby release IRQ enable register (SSIER)

7.3.1 Interrupt Control Register (INTCR)

INTCR selects the interrupt control mode, and the edge which detects NMI.

Bit	7	6	5	4	3	2	1	0
Bit Name	—	—	INTM1	INTM0	NMIEG	—	—	—
Initial Value	0	0	0	0	0	0	0	0
R/W	R	R	R/W	R/W	R/W	R	R	R

Bit	Bit Name	Initial Value	R/W	Description
7	—	0	R	Reserved
6	—	0	R	These are read-only bits and cannot be modified.
5	INTM1	0	R/W	Interrupt Control Select Mode 1 and 0
4	INTM0	0	R/W	These bits select either of two interrupt control modes for the interrupt controller. 00: Interrupt control mode 0 Interrupts are controlled by I bit in CCR. 01: Setting prohibited. 10: Interrupt control mode 2 Interrupts are controlled by bits I2 to I0 in EXR, and IPR. 11: Setting prohibited.
3	NMIEG	0	R/W	NMI Edge Select Selects the input edge for the NMI pin. 0: Interrupt request generated at falling edge of NMI input 1: Interrupt request generated at rising edge of NMI input
2 to 0	—	All 0	R	Reserved These are read-only bits and cannot be modified.

7.3.2 CPU Priority Control Register (CPUPCR)

CPUPCR sets whether or not the CPU has priority over the DTC and DMAC. The interrupt exception handling by the CPU can be given priority over that of the DTC and DMAC transfer. The priority level of the DTC is set by bits DTCP2 to DTCP0 in CPUPCR. The priority level of the DMAC is set by the DMAC control register for each channel.

Bit	7	6	5	4	3	2	1	0
Bit Name	CPUPCE	DTCP2	DTCP1	DTCP0	IPSETE	CPUP2	CPUP1	CPUP0
Initial Value	0	0	0	0	0	0	0	0
R/W	R/W	R/W	R/W	R/W	R/W	R/(W)*	R/(W)*	R/(W)*

Note: * When the IPSETE bit is set to 1, the CPU priority is automatically updated, so these bits cannot be modified.

Bit	Bit Name	Initial Value	R/W	Description
7	CPUPCE	0	R/W	<p>CPU Priority Control Enable</p> <p>Controls the CPU priority control function. Setting this bit to 1 enables the CPU priority control over the DTC and DMAC.</p> <p>0: CPU always has the lowest priority 1: CPU priority control enabled</p>
6	DTCP2	0	R/W	DTC Priority Level 2 to 0
5	DTCP1	0	R/W	These bits set the DTC priority level.
4	DTCP0	0	R/W	<p>000: Priority level 0 (lowest)</p> <p>001: Priority level 1</p> <p>010: Priority level 2</p> <p>011: Priority level 3</p> <p>100: Priority level 4</p> <p>101: Priority level 5</p> <p>110: Priority level 6</p> <p>111: Priority level 7 (highest)</p>
3	IPSETE	0	R/W	<p>Interrupt Priority Set Enable</p> <p>Controls the function which automatically assigns the interrupt priority level of the CPU. Setting this bit to 1 automatically sets bits CPUP2 to CPUP0 by the CPU interrupt mask bit (I bit in CCR or bits I2 to I0 in EXR).</p> <p>0: Bits CPUP2 to CPUP0 are not updated automatically 1: The interrupt mask bit value is reflected in bits CPUP2 to CPUP0</p>

Bit	Bit Name	Initial Value	R/W	Description
2	CPUP2	0	R/(W)*	CPU Priority Level 2 to 0
1	CPUP1	0	R/(W)*	These bits set the CPU priority level. When the CPUPCE is set to 1, the CPU priority control function over the DTC and DMAC becomes valid and the priority of CPU processing is assigned in accordance with the settings of bits CPUP2 to CPUP0.
0	CPUP0	0	R/(W)*	
				000: Priority level 0 (lowest)
				001: Priority level 1
				010: Priority level 2
				011: Priority level 3
				100: Priority level 4
				101: Priority level 5
				110: Priority level 6
				111: Priority level 7 (highest)

Note: * When the IPSETE bit is set to 1, the CPU priority is automatically updated, so these bits cannot be modified.

7.3.3 Interrupt Priority Registers A to I, K to O, Q, and R (IPRA to IPRI, IPRK to IPRO, IPRQ, and IPRR)

IPR sets priority (levels 7 to 0) for interrupts other than NMI.

Setting a value in the range from B'000 to B'111 in the 3-bit groups of bits 14 to 12, 10 to 8, 6 to 4, and 2 to 0 assigns a priority level to the corresponding interrupt. For the correspondence between the interrupt sources and the IPR settings, see table 7.2.

Bit	15	14	13	12	11	10	9	8
Bit Name	—	IPR14	IPR13	IPR12	—	IPR10	IPR9	IPR8
Initial Value	0	1	1	1	0	1	1	1
R/W	R	R/W	R/W	R/W	R	R/W	R/W	R/W
Bit	7	6	5	4	3	2	1	0
Bit Name	—	IPR6	IPR5	IPR4	—	IPR2	IPR1	IPR0
Initial Value	0	1	1	1	0	1	1	1
R/W	R	R/W	R/W	R/W	R	R/W	R/W	R/W

Bit	Bit Name	Initial Value	R/W	Description
15	—	0	R	Reserved This is a read-only bit and cannot be modified.
14	IPR14	1	R/W	Sets the priority level of the corresponding interrupt source.
13	IPR13	1	R/W	
12	IPR12	1	R/W	000: Priority level 0 (lowest) 001: Priority level 1 010: Priority level 2 011: Priority level 3 100: Priority level 4 101: Priority level 5 110: Priority level 6 111: Priority level 7 (highest)
11	—	0	R	Reserved This is a read-only bit and cannot be modified.
10	IPR10	1	R/W	Sets the priority level of the corresponding interrupt source.
9	IPR9	1	R/W	
8	IPR8	1	R/W	000: Priority level 0 (lowest) 001: Priority level 1 010: Priority level 2 011: Priority level 3 100: Priority level 4 101: Priority level 5 110: Priority level 6 111: Priority level 7 (highest)
7	—	0	R	Reserved This is a read-only bit and cannot be modified.
6	IPR6	1	R/W	Sets the priority level of the corresponding interrupt source.
5	IPR5	1	R/W	
4	IPR4	1	R/W	000: Priority level 0 (lowest) 001: Priority level 1 010: Priority level 2 011: Priority level 3 100: Priority level 4 101: Priority level 5 110: Priority level 6 111: Priority level 7 (highest)

Bit	Bit Name	Initial Value	R/W	Description
3	—	0	R	Reserved This is a read-only bit and cannot be modified.
2	IPR2	1	R/W	Sets the priority level of the corresponding interrupt source.
1	IPR1	1	R/W	
0	IPR0	1	R/W	000: Priority level 0 (lowest) 001: Priority level 1 010: Priority level 2 011: Priority level 3 100: Priority level 4 101: Priority level 5 110: Priority level 6 111: Priority level 7 (highest)

7.3.4 IRQ Enable Register (IER)

IER enables interrupt requests IRQ15 to IRQ0.

Bit	15	14	13	12	11	10	9	8
Bit Name	IRQ15E	IRQ14E	IRQ13E	IRQ12E	IRQ11E	IRQ10E	IRQ9E	IRQ8E
Initial Value	0	0	0	0	0	0	0	0
R/W	R/W	R/W	R/W	R/W	R/W	R/W	R/W	R/W
Bit	7	6	5	4	3	2	1	0
Bit Name	IRQ7E	IRQ6E	IRQ5E	IRQ4E	IRQ3E	IRQ2E	IRQ1E	IRQ0E
Initial Value	0	0	0	0	0	0	0	0
R/W	R/W	R/W	R/W	R/W	R/W	R/W	R/W	R/W

Bit	Bit Name	Initial Value	R/W	Description
15	IRQ15E	0	R/W	IRQ15 Enable The IRQ15 interrupt request is enabled when this bit is 1.
14	IRQ14E	0	R/W	IRQ14 Enable The IRQ14 interrupt request is enabled when this bit is 1. The voltage-monitoring interrupt in the LVD* is enabled.
13	IRQ13E	0	R/W	IRQ13 Enable The IRQ13 interrupt request is enabled when this bit is 1.

Bit	Bit Name	Initial Value	R/W	Description
12	IRQ12E	0	R/W	IRQ12 Enable The IRQ12 interrupt request is enabled when this bit is 1.
11	IRQ11E	0	R/W	IRQ11 Enable The IRQ11 interrupt request is enabled when this bit is 1.
10	IRQ10E	0	R/W	IRQ10 Enable The IRQ10 interrupt request is enabled when this bit is 1.
9	IRQ9E	0	R/W	IRQ9 Enable The IRQ9 interrupt request is enabled when this bit is 1.
8	IRQ8E	0	R/W	IRQ8 Enable The IRQ8 interrupt request is enabled when this bit is 1.
7	IRQ7E	0	R/W	IRQ7 Enable The IRQ7 interrupt request is enabled when this bit is 1.
6	IRQ6E	0	R/W	IRQ6 Enable The IRQ6 interrupt request is enabled when this bit is 1.
5	IRQ5E	0	R/W	IRQ5 Enable The IRQ5 interrupt request is enabled when this bit is 1.
4	IRQ4E	0	R/W	IRQ4 Enable The IRQ4 interrupt request is enabled when this bit is 1.
3	IRQ3E	0	R/W	IRQ3 Enable The IRQ3 interrupt request is enabled when this bit is 1.
2	IRQ2E	0	R/W	IRQ2 Enable The IRQ2 interrupt request is enabled when this bit is 1.
1	IRQ1E	0	R/W	IRQ1 Enable The IRQ1 interrupt request is enabled when this bit is 1.
0	IRQ0E	0	R/W	IRQ0 Enable The IRQ0 interrupt request is enabled when this bit is 1.

Note: * Supported only by the H8SX/1638 Group.

7.3.5 IRQ Sense Control Registers H and L (ISCRH, ISCR L)

ISCRH and ISCR L select the source that generates an interrupt request from IRQ15 to IRQ0 input.

Upon changing the setting of ISCR, IRQnF (n = 0 to 15) in ISR is often set to 1 accidentally through an internal operation. In this case, an interrupt exception handling is executed if an IRQn interrupt request is enabled. In order to prevent such an accidental interrupt from occurring, the setting of ISCR should be changed while the IRQn interrupt is disabled, and then the IRQnF in ISR should be cleared to 0.

- ISCRH

Bit	15	14	13	12	11	10	9	8
Bit Name	IRQ15SR	IRQ15SF	IRQ14SR	IRQ14SF	IRQ13SR	IRQ13SF	IRQ12SR	IRQ12SF
Initial Value	0	0	0	0	0	0	0	0
R/W	R/W	R/W	R/W	R/W	R/W	R/W	R/W	R/W
Bit	7	6	5	4	3	2	1	0
Bit Name	IRQ11SR	IRQ11SF	IRQ10SR	IRQ10SF	IRQ9SR	IRQ9SF	IRQ8SR	IRQ8SF
Initial Value	0	0	0	0	0	0	0	0
R/W	R/W	R/W	R/W	R/W	R/W	R/W	R/W	R/W

- ISCR L

Bit	15	14	13	12	11	10	9	8
Bit Name	IRQ7SR	IRQ7SF	IRQ6SR	IRQ6SF	IRQ5SR	IRQ5SF	IRQ4SR	IRQ4SF
Initial Value	0	0	0	0	0	0	0	0
R/W	R/W	R/W	R/W	R/W	R/W	R/W	R/W	R/W
Bit	7	6	5	4	3	2	1	0
Bit Name	IRQ3SR	IRQ3SF	IRQ2SR	IRQ2SF	IRQ1SR	IRQ1SF	IRQ0SR	IRQ0SF
Initial Value	0	0	0	0	0	0	0	0
R/W	R/W	R/W	R/W	R/W	R/W	R/W	R/W	R/W

- ISCRH

Bit	Bit Name	Initial Value	R/W	Description
15	IRQ15SR	0	R/W	IRQ15 Sense Control Rise
14	IRQ15SF	0	R/W	IRQ15 Sense Control Fall
				00: Interrupt request generated by low level of $\overline{\text{IRQ15}}$ 01: Interrupt request generated at falling edge of $\overline{\text{IRQ15}}$ 10: Interrupt request generated at rising edge of $\overline{\text{IRQ15}}$ 11: Interrupt request generated at both falling and rising edges of $\overline{\text{IRQ15}}$
13	IRQ14SR	0	R/W	IRQ14 Sense Control Rise
12	IRQ14SF	0	R/W	IRQ14 Sense Control Fall
				<ul style="list-style-type: none"> When used as IRQ14 00: Interrupt request generated by low level of $\overline{\text{IRQ14}}$ 01: Interrupt request generated at falling edge of $\overline{\text{IRQ14}}$ 10: Interrupt request generated at rising edge of $\overline{\text{IRQ14}}$ 11: Interrupt request generated at both falling and rising edges of $\overline{\text{IRQ14}}$
				<ul style="list-style-type: none"> LVD*: When used as a voltage-monitoring interrupt IRQ14 is used as the LVD voltage-monitoring interrupt. IRQ14 is generated at falling edge of $\overline{\text{IRQ14}}$. 00: Initial value 01: Interrupt request generated at falling edge of $\overline{\text{IRQ14}}$ 10: Setting prohibited 11: Setting prohibited
11	IRQ13SR	0	R/W	IRQ13 Sense Control Rise
10	IRQ13SF	0	R/W	IRQ13 Sense Control Fall
				00: Interrupt request generated by low level of $\overline{\text{IRQ13}}$ 01: Interrupt request generated at falling edge of $\overline{\text{IRQ13}}$ 10: Interrupt request generated at rising edge of $\overline{\text{IRQ13}}$ 11: Interrupt request generated at both falling and rising edges of $\overline{\text{IRQ13}}$

Bit	Bit Name	Initial Value	R/W	Description
9	IRQ12SR	0	R/W	IRQ12 Sense Control Rise
8	IRQ12SF	0	R/W	IRQ12 Sense Control Fall
				00: Interrupt request generated by low level of $\overline{\text{IRQ12}}$ 01: Interrupt request generated at falling edge of $\overline{\text{IRQ12}}$ 10: Interrupt request generated at rising edge of $\overline{\text{IRQ12}}$ 11: Interrupt request generated at both falling and rising edges of $\overline{\text{IRQ12}}$
7	IRQ11SR	0	R/W	IRQ11 Sense Control Rise
6	IRQ11SF	0	R/W	IRQ11 Sense Control Fall
				00: Interrupt request generated by low level of $\overline{\text{IRQ11}}$ 01: Interrupt request generated at falling edge of $\overline{\text{IRQ11}}$ 10: Interrupt request generated at rising edge of $\overline{\text{IRQ11}}$ 11: Interrupt request generated at both falling and rising edges of $\overline{\text{IRQ11}}$
5	IRQ10SR	0	R/W	IRQ10 Sense Control Rise
4	IRQ10SF	0	R/W	IRQ10 Sense Control Fall
				00: Interrupt request generated by low level of $\overline{\text{IRQ10}}$ 01: Interrupt request generated at falling edge of $\overline{\text{IRQ10}}$ 10: Interrupt request generated at rising edge of $\overline{\text{IRQ10}}$ 11: Interrupt request generated at both falling and rising edges of $\overline{\text{IRQ10}}$
3	IRQ9SR	0	R/W	IRQ9 Sense Control Rise
2	IRQ9SF	0	R/W	IRQ9 Sense Control Fall
				00: Interrupt request generated by low level of $\overline{\text{IRQ9}}$ 01: Interrupt request generated at falling edge of $\overline{\text{IRQ9}}$ 10: Interrupt request generated at rising edge of $\overline{\text{IRQ9}}$ 11: Interrupt request generated at both falling and rising edges of $\overline{\text{IRQ9}}$
1	IRQ8SR	0	R/W	IRQ8 Sense Control Rise
0	IRQ8SF	0	R/W	IRQ8 Sense Control Fall
				00: Interrupt request generated by low level of $\overline{\text{IRQ8}}$ 01: Interrupt request generated at falling edge of $\overline{\text{IRQ8}}$ 10: Interrupt request generated at rising edge of $\overline{\text{IRQ8}}$ 11: Interrupt request generated at both falling and rising edges of $\overline{\text{IRQ8}}$

Note: * Supported only by the H8SX/1638L Group.

- ISCR_L

Bit	Bit Name	Initial Value	R/W	Description
15	IRQ7SR	0	R/W	IRQ7 Sense Control Rise
14	IRQ7SF	0	R/W	IRQ7 Sense Control Fall
				00: Interrupt request generated by low level of $\overline{\text{IRQ7}}$ 01: Interrupt request generated at falling edge of $\overline{\text{IRQ7}}$ 10: Interrupt request generated at rising edge of $\overline{\text{IRQ7}}$ 11: Interrupt request generated at both falling and rising edges of $\overline{\text{IRQ7}}$
13	IRQ6SR	0	R/W	IRQ6 Sense Control Rise
12	IRQ6SF	0	R/W	IRQ6 Sense Control Fall
				00: Interrupt request generated by low level of $\overline{\text{IRQ6}}$ 01: Interrupt request generated at falling edge of $\overline{\text{IRQ6}}$ 10: Interrupt request generated at rising edge of $\overline{\text{IRQ6}}$ 11: Interrupt request generated at both falling and rising edges of $\overline{\text{IRQ6}}$
11	IRQ5SR	0	R/W	IRQ5 Sense Control Rise
10	IRQ5SF	0	R/W	IRQ5 Sense Control Fall
				00: Interrupt request generated by low level of $\overline{\text{IRQ5}}$ 01: Interrupt request generated at falling edge of $\overline{\text{IRQ5}}$ 10: Interrupt request generated at rising edge of $\overline{\text{IRQ5}}$ 11: Interrupt request generated at both falling and rising edges of $\overline{\text{IRQ5}}$
9	IRQ4SR	0	R/W	IRQ4 Sense Control Rise
8	IRQ4SF	0	R/W	IRQ4 Sense Control Fall
				00: Interrupt request generated by low level of $\overline{\text{IRQ4}}$ 01: Interrupt request generated at falling edge of $\overline{\text{IRQ4}}$ 10: Interrupt request generated at rising edge of $\overline{\text{IRQ4}}$ 11: Interrupt request generated at both falling and rising edges of $\overline{\text{IRQ4}}$
7	IRQ3SR	0	R/W	IRQ3 Sense Control Rise
6	IRQ3SF	0	R/W	IRQ3 Sense Control Fall
				00: Interrupt request generated by low level of $\overline{\text{IRQ3}}$ 01: Interrupt request generated at falling edge of $\overline{\text{IRQ3}}$ 10: Interrupt request generated at rising edge of $\overline{\text{IRQ3}}$ 11: Interrupt request generated at both falling and rising edges of $\overline{\text{IRQ3}}$

Bit	Bit Name	Initial Value	R/W	Description
5	IRQ2SR	0	R/W	IRQ2 Sense Control Rise
4	IRQ2SF	0	R/W	IRQ2 Sense Control Fall
				00: Interrupt request generated by low level of $\overline{\text{IRQ2}}$ 01: Interrupt request generated at falling edge of $\overline{\text{IRQ2}}$ 10: Interrupt request generated at rising edge of $\overline{\text{IRQ2}}$ 11: Interrupt request generated at both falling and rising edges of $\overline{\text{IRQ2}}$
3	IRQ1SR	0	R/W	IRQ1 Sense Control Rise
2	IRQ1SF	0	R/W	IRQ1 Sense Control Fall
				00: Interrupt request generated by low level of $\overline{\text{IRQ1}}$ 01: Interrupt request generated at falling edge of $\overline{\text{IRQ1}}$ 10: Interrupt request generated at rising edge of $\overline{\text{IRQ1}}$ 11: Interrupt request generated at both falling and rising edges of $\overline{\text{IRQ1}}$
1	IRQ0SR	0	R/W	IRQ0 Sense Control Rise
0	IRQ0SF	0	R/W	IRQ0 Sense Control Fall
				00: Interrupt request generated by low level of $\overline{\text{IRQ0}}$ 01: Interrupt request generated at falling edge of $\overline{\text{IRQ0}}$ 10: Interrupt request generated at rising edge of $\overline{\text{IRQ0}}$ 11: Interrupt request generated at both falling and rising edges of $\overline{\text{IRQ0}}$

7.3.6 IRQ Status Register (ISR)

ISR is an IRQ15 to IRQ0 interrupt request register.

Bit	15	14	13	12	11	10	9	8
Bit Name	IRQ15F	IRQ14F	IRQ13F	IRQ12F	IRQ11F	IRQ10F	IRQ9F	IRQ8F
Initial Value	0	0	0	0	0	0	0	0
R/W	R/(W)*	R/(W)*	R/(W)*	R/(W)*	R/(W)*	R/(W)*	R/(W)*	R/(W)*
Bit	7	6	5	4	3	2	1	0
Bit Name	IRQ7F	IRQ6F	IRQ5F	IRQ4F	IRQ3F	IRQ2F	IRQ1F	IRQ0F
Initial Value	0	0	0	0	0	0	0	0
R/W	R/(W)*	R/(W)*	R/(W)*	R/(W)*	R/(W)*	R/(W)*	R/(W)*	R/(W)*

Note: * Only 0 can be written, to clear the flag. The bit manipulation instructions or memory operation instructions should be used to clear the flag.

Bit	Bit Name	Initial Value	R/W	Description
15	IRQ15F	0	R/(W)* ¹	[Setting condition] <ul style="list-style-type: none"> When the interrupt selected by ISCR occurs [Clearing conditions] <ul style="list-style-type: none"> Writing 0 after reading IRQ15F = 1 When interrupt exception handling is executed while low-level sensing is selected and $\overline{\text{IRQ15}}$ input is high When IRQ15 interrupt exception handling is executed while falling-, rising-, or both-edge sensing is selected When the DTC is activated by an IRQ15 interrupt, and the DISEL bit in MRB of the DTC is cleared to 0

Bit	Bit Name	Initial Value	R/W	Description
14	IRQ14F	0	R/(W)* ¹	<p>When used as IRQ14:</p> <p>[Setting condition]</p> <ul style="list-style-type: none"> When the interrupt selected by ISCR occurs <p>[Clearing conditions]</p> <ul style="list-style-type: none"> Writing 0 after reading IRQ14F = 1 When interrupt exception handling is executed while low-level sensing is selected and IRQ14 input is high When IRQ14 interrupt exception handling is executed while falling-, rising-, or both-edge sensing is selected When the DTC is activated by an IRQ14 interrupt, and the DISEL bit in MRB of the DTC is cleared to 0 <p>LVD*²: When used as a voltage-monitoring interrupt</p> <p>[Setting condition]</p> <ul style="list-style-type: none"> When the interrupt selected by ISCR occurs <p>[Clearing condition]</p> <ul style="list-style-type: none"> Writing 0 after reading IRQ14F = 1 <p>When IRQn interrupt exception handling is executed while falling-edge sensing is selected</p>

Bit	Bit Name	Initial Value	R/W	Description
13	IRQ13F	0	R/(W)* ¹	[Setting condition]
12	IRQ12F	0	R/(W)* ¹	• When the interrupt selected by ISCR occurs
11	IRQ11F	0	R/(W)* ¹	[Clearing conditions]
10	IRQ10F	0	R/(W)* ¹	• Writing 0 after reading IRQnF = 1 (n=13 to 0)
9	IRQ9F	0	R/(W)* ¹	• When interrupt exception handling is executed while
8	IRQ8F	0	R/(W)* ¹	low-level sensing is selected and IRQn input is high
7	IRQ7F	0	R/(W)* ¹	• When IRQn interrupt exception handling is executed
6	IRQ6F	0	R/(W)* ¹	while falling-, rising-, or both-edge sensing is
5	IRQ5F	0	R/(W)* ¹	selected
4	IRQ4F	0	R/(W)* ¹	When the DTC is activated by an IRQn interrupt, and the
3	IRQ3F	0	R/(W)* ¹	DISEL bit in MRB of the DTC is cleared to 0
2	IRQ2F	0	R/(W)* ¹	
1	IRQ1F	0	R/(W)* ¹	
0	IRQ0F	0	R/(W)* ¹	

- Notes: 1. Only 0 can be written, to clear the flag.
2. Supported only by the H8SX/1638L Group.

7.3.7 Software Standby Release IRQ Enable Register (SSIER)

SSIER selects the IRQ interrupt used to leave software standby mode.

The IRQ interrupt used to leave software standby mode should not be set as the DTC activation source.

Bit	15	14	13	12	11	10	9	8
Bit Name	SSI15	SSI14	SSI13	SSI12	SSI11	SSI10	SSI9	SSI8
Initial Value	0	0	0	0	0	0	0	0
R/W	R/W	R/W	R/W	R/W	R/W	R/W	R/W	R/W
Bit	7	6	5	4	3	2	1	0
Bit Name	SSI7	SSI6	SSI5	SSI4	SSI3	SSI2	SSI1	SSI0
Initial Value	0	0	0	0	0	0	0	0
R/W	R/W	R/W	R/W	R/W	R/W	R/W	R/W	R/W

Bit	Bit Name	Initial Value	R/W	Description
15	SSI15	0	R/W	Software Standby Release IRQ Setting
14	SSI14	0	R/W	These bits select the IRQ _n interrupt used to leave software standby mode (n = 15 to 0).
13	SSI13	0	R/W	
12	SSI12	0	R/W	0: An IRQ _n request is not sampled in software standby mode
11	SSI11	0	R/W	1: When an IRQ _n request occurs in software standby mode, this LSI leaves software standby mode after the oscillation settling time has elapsed
10	SSI10	0	R/W	
9	SSI9	0	R/W	
8	SSI8	0	R/W	
7	SSI7	0	R/W	
6	SSI6	0	R/W	
5	SSI5	0	R/W	
4	SSI4	0	R/W	
3	SSI3	0	R/W	
2	SSI2	0	R/W	
1	SSI1	0	R/W	
0	SSI0	0	R/W	

7.4 Interrupt Sources

7.4.1 External Interrupts

There are seventeen external interrupts: NMI and IRQ15 to IRQ0. These interrupts can be used to leave software standby mode.

(1) NMI Interrupts

Nonmaskable interrupt request (NMI) is the highest-priority interrupt, and is always accepted by the CPU regardless of the interrupt control mode or the settings of the CPU interrupt mask bits. The NMIEG bit in INTCR selects whether an interrupt is requested at the rising or falling edge on the NMI pin.

When an NMI interrupt is generated, the interrupt controller determines that an error has occurred, and performs the following procedure.

- Sets the ERR bit of DTCCR in the DTC to 1.
- Sets the ERRF bit of DMDR_0 in the DMAC to 1
- Clears the DTE bits of DMDRs for all channels in the DMAC to 0 to forcibly terminate transfer

(2) IRQn Interrupts

An IRQn interrupt is requested by a signal input on pins $\overline{\text{IRQ15}}$ to $\overline{\text{IRQ0}}$. $\overline{\text{IRQn}}$ (n = 15 to 0) have the following features:

- Using ISCR, it is possible to select whether an interrupt is generated by a low level, falling edge, rising edge, or both edges, on pins $\overline{\text{IRQn}}$.
- Enabling or disabling of interrupt requests IRQn can be selected by IER.
- The interrupt priority can be set by IPR.
- The status of interrupt requests IRQn is indicated in ISR. ISR flags can be cleared to 0 by software. The bit manipulation instructions and memory operation instructions should be used to clear the flag.

Detection of IRQ_n interrupts is enabled through the P1ICR, P2ICR, P5ICR, and P6ICR register settings, and does not change regardless of the output setting. However, when a pin is used as an external interrupt input pin, the pin must not be used as an I/O pin for another function by clearing the corresponding DDR bit to 0.

A block diagram of interrupts IRQ_n is shown in figure 7.2.

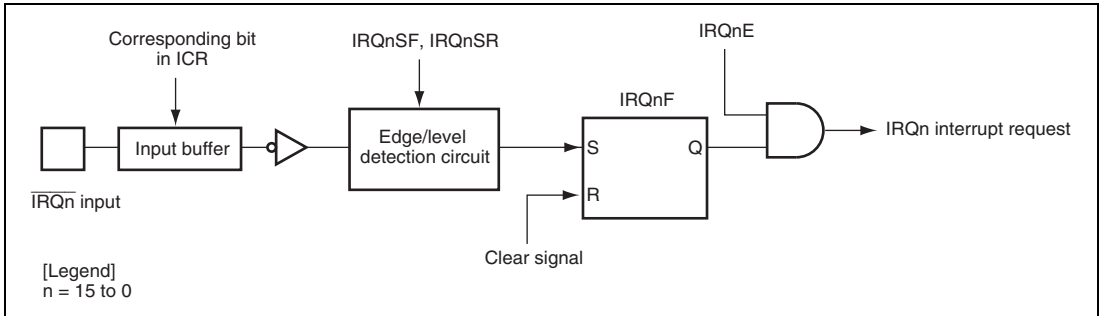

Figure 7.2 Block Diagram of Interrupts IRQ_n

When the IRQ sensing control in ISCR is set to a low level of signal $\overline{IRQ_n}$, the level of $\overline{IRQ_n}$ should be held low until an interrupt handling starts. Then set the corresponding input signal $\overline{IRQ_n}$ to high in the interrupt handling routine and clear the IRQ_nF to 0. Interrupts may not be executed when the corresponding input signal $\overline{IRQ_n}$ is set to high before the interrupt handling begins.

7.4.2 Internal Interrupts

The sources for internal interrupts from on-chip peripheral modules have the following features:

- For each on-chip peripheral module there are flags that indicate the interrupt request status, and enable bits that enable or disable these interrupts. They can be controlled independently. When the enable bit is set to 1, an interrupt request is issued to the interrupt controller.
- The interrupt priority can be set by means of IPR.
- The DTC and DMAC can be activated by a TPU, SCI, or other interrupt request.
- The priority levels of DTC and DMAC activation can be controlled by the DTC and DMAC priority control functions.

7.5 Interrupt Exception Handling Vector Table

Table 7.2 lists interrupt exception handling sources, vector address offsets, and interrupt priority.

In the default priority order, a lower vector number corresponds to a higher priority. When interrupt control mode 2 is set, priority levels can be changed by setting the IPR contents. The priority for interrupt sources allocated to the same level in IPR follows the default priority, that is, they are fixed.

Table 7.2 Interrupt Sources, Vector Address Offsets, and Interrupt Priority

Classification	Interrupt Source	Vector Number	Vector Address Offset* ¹		Priority	DTC Activation	DMAC Activation
			Advanced Mode Middle Mode Maximum Mode	IPR			
External pin	NMI	7	H'001C	—	High	—	—
UBC	UBC break interrupt	14	H'0038	—	↑	—	—
External pin	IRQ0	64	H'0100	IPRA14 to IPRA12		O	—
	IRQ1	65	H'0104	IPRA10 to IPRA8		O	—
	IRQ2	66	H'0108	IPRA6 to IPRA4		O	—
	IRQ3	67	H'010C	IPRA2 to IPRA0		O	—
	IRQ4	68	H'0110	IPRB14 to IPRB12		O	—
	IRQ5	69	H'0114	IPRB10 to IPRB8		O	—
	IRQ6	70	H'0118	IPRB6 to IPRB4		O	—
	IRQ7	71	H'011C	IPRB2 to IPRB0		O	—
	IRQ8	72	H'0120	IPRC14 to IPRC12		O	—
	IRQ9	73	H'0124	IPRC10 to IPRC8		O	—
	IRQ10	74	H'0128	IPRC6 to IPRC4		O	—
	IRQ11	75	H'012C	IPRC2 to IPRC0		O	—
	IRQ12	76	H'0130	IPRD14 to IPRD12		O	—
	IRQ13	77	H'0134	IPRD10 to IPRD8		O	—
IRQ14	78	H'0138	IPRD6 to IPRD4	O	—		
LVD* ²	Voltage-monitoring interrupt				—	—	
External pin	IRQ15	79	H'013C	IPRD2 to IPRD0	O	—	
—	Reserved for system use	80	H'0140	—	—	—	
WDT	WOVI	81	H'0144	IPRE10 to IPRE8	Low	—	—

Classification	Interrupt Source	Vector Number	Vector Address Offset ^{#1}		Priority	DTC Activation	DMAC Activation
			Advanced Mode	Middle Mode Maximum Mode			
				IPR			
—	Reserved for system use	82	H'0148	—	High	—	—
—	Reserved for system use	83	H'014C	—	↑	—	—
—	Reserved for system use	84	H'0150	—		—	—
—	Reserved for system use	85	H'0154	—		—	—
A/D_0	ADI0	86	H'0158	IPRF10 to IPRF8		O	O
—	Reserved for system use	87	H'015C	—		—	—
TPU_0	TGI0A	88	H'0160	IPRF6 to IPRF4		O	O
	TGI0B	89	H'0164			O	—
	TGI0C	90	H'0168			O	—
	TGI0D	91	H'016C			O	—
	TCI0V	92	H'0170			—	—
TPU_1	TGI1A	93	H'0174	IPRF2 to IPRF0	O	O	
	TGI1B	94	H'0178		O	—	
	TCI1V	95	H'017C		—	—	
	TCI1U	96	H'0180		—	—	
TPU_2	TGI2A	97	H'0184	IPRG14 to IPRG12	O	O	
	TGI2B	98	H'0188		O	—	
	TCI2V	99	H'018C		—	—	
	TCI2U	100	H'0190		—	—	
TPU_3	TGI3A	101	H'0194	IPRG10 to IPRG8	O	O	
	TGI3B	102	H'0198		O	—	
	TGI3C	103	H'019C		O	—	
	TGI3D	104	H'01A0		O	—	
	TCI3V	105	H'01A4		—	—	
TPU_4	TGI4A	106	H'01A8	IPRG6 to IPRG4	O	O	
	TGI4B	107	H'01AC		O	—	
	TCI4V	108	H'01B0		—	—	
	TCI4U	109	H'01B4		—	—	
					Low		

Classification	Interrupt Source	Vector Number	Vector Address Offset*1		IPR	Priority	DTC Activation	DMAC Activation
			Advanced Mode	Middle Mode				
			Maximum Mode					
—	Reserved for system use	140	H'0230	—				
		141	H'0234	—				
		142	H'0238	—				
		143	H'023C	—				
SCI_0	ERI0	144	H'0240	IPRK6 to IPRK4				
	RXI0	145	H'0244	—				
	TXI0	146	H'0248	O O				
	TEI0	147	H'024C	— —				
SCI_1	ERI1	148	H'0250	IPRK2 to IPRK0				
	RXI1	149	H'0254	— —				
	TXI1	150	H'0258	O O				
	TEI1	151	H'025C	— —				
SCI_2	ERI2	152	H'0260	IPRL14 to IPRL12				
	RXI2	153	H'0264	— —				
	TXI2	154	H'0268	O O				
	TEI2	155	H'026C	— —				
SCI_3	ERI3	156	H'0270	IPRL10 to IPRL8				
	RXI3	157	H'0274	— —				
	TXI3	158	H'0278	O O				
	TEI3	159	H'027C	— —				
SCI_4	ERI4	160	H'0280	IPRL6 to IPRL4				
	RXI4	161	H'0284	— —				
	TXI4	162	H'0288	O O				
	TEI4	163	H'028C	— —				

High



Low

Classification	Interrupt Source	Vector Number	Vector Address Offset*1		Priority	DTC Activation	DMAC Activation	
			Advanced Mode Middle Mode Maximum Mode	IPR				
TPU_6	TGI6A	164	H'0290	IPRL2 to IPRL0	High	O	O	
	TGI6B	165	H'0294			O	—	
	TGI6C	166	H'0298			O	—	
	TGI6D	167	H'029C			O	—	
	TCI6V	168	H'02A0			IPRM14 to IPRM12	—	—
TPU_7	TGI7A	169	H'02A4	IPRM10 to IPRM8	↑	O	O	
	TGI7B	170	H'02A8			O	—	
	TCI7V	171	H'02AC			IPRM6 to IPRM4	—	—
	TCI7U	172	H'02B0			—	—	
TPU_8	TGI8A	173	H'02B4	IPRM2 to IPRM0	↑	O	O	
	TGI8B	174	H'02B8			O	—	
	TCI8V	175	H'02BC			IPRN14 to IPRN12	—	—
	TCI8U	176	H'02C0			—	—	
TPU_9	TGI9A	177	H'02C4	IPRN10 to IPRN8	↑	O	O	
	TGI9B	178	H'02C8			O	—	
	TGI9C	179	H'02CC			O	—	
	TGI9D	180	H'02D0			O	—	
	TCI9V	181	H'02D4			IPRN6 to IPRN4	—	—
TPU_10	TGI10A	182	H'02D8	IPRN2 to IPRN0	↑	O	O	
	TGI10B	183	H'02DC			O	—	
	Reserved for system use	184	H'02E0			—	—	
	Reserved for system use	185	H'02E4			—	—	
	TCI10V	186	H'02E8			IPRO14 to IPRO12	O	—
	TCI10U	187	H'02EC			—	—	
TPU_11	TGI11A	188	H'02F0	IPRO10 to IPRO8	↑	O	O	
	TGI11B	189	H'02F4			O	—	
	TCI11V	190	H'02F8			IPRO6 to IPRO4	—	—
	TCI11U	191	H'02FC			—	—	

Low

Classification	Interrupt Source	Vector Number	Vector Address Offset* ¹		IPR	Priority	DTC Activation	DMAC Activation
			Advanced Mode	Middle Mode Maximum Mode				
—	Reserved for system use	192	H'0300		—	High	—	—
		215	H'035C				—	—
IIC2_0	IIC10	216	H'0360		IPRQ6 to IPRQ4		—	—
—	Reserved for system use	217	H'0364				—	—
IIC2_1	IIC11	218	H'0368				—	—
—	Reserved for system use	219	H'036C				—	—
SCI_5	RX15	220	H'0370		IPRQ2 to IPRQ0		—	O
	TX15	221	H'0374				—	O
	ERI5	222	H'0378				—	—
	TEI5	223	H'037C				—	—
SCI_6	RX16	224	H'0380		IPRR14 to IPRR12		—	O
	TX16	225	H'0384				—	O
	ERI6	226	H'0388				—	—
	TEI6	227	H'038C				—	—
TMR_4	CMIA4 or CMIB4	228	H'0390		IPRR10 to IPRR8		—	—
TMR_5	CMIA5 or CMIB5	229	H'0394				—	—
TMR_6	CMIA6 or CMIB6	230	H'0398				—	—
TMR_7	CMIA7 or CMIB7	231	H'039C				—	—
—	Reserved for system use	232	H'03A0		—		—	—
		236	H'03B0		—		—	—
A/D_1	ADI1	237	H'03B4		IPRR2 to IPRR0		—	O
—	Reserved for system use	238	H'03B8		—		—	—
		255	H'03FC		—		Low	—

- Notes: 1. Lower 16 bits of the start address.
2. Supported only by the H8SX/1638L Group.

7.6 Interrupt Control Modes and Interrupt Operation

The interrupt controller has two interrupt control modes: interrupt control mode 0 and interrupt control mode 2. Interrupt operations differ depending on the interrupt control mode. The interrupt control mode is selected by INTCR. Table 7.3 shows the differences between interrupt control mode 0 and interrupt control mode 2.

Table 7.3 Interrupt Control Modes

Interrupt Control Mode	Priority Setting Register	Interrupt Mask Bit	Description
0	Default	I	The priority levels of the interrupt sources are fixed default settings. The interrupts except for NMI is masked by the I bit.
2	IPR	I2 to I0	Eight priority levels can be set for interrupt sources except for NMI with IPR. 8-level interrupt mask control is performed by bits I2 to I0.

7.6.1 Interrupt Control Mode 0

In interrupt control mode 0, interrupt requests except for NMI are masked by the I bit in CCR of the CPU. Figure 7.3 shows a flowchart of the interrupt acceptance operation in this case.

1. If an interrupt request occurs when the corresponding interrupt enable bit is set to 1, the interrupt request is sent to the interrupt controller.
2. If the I bit in CCR is set to 1, NMI is accepted, and other interrupt requests are held pending. If the I bit is cleared to 0, an interrupt request is accepted.
3. For multiple interrupt requests, the interrupt controller selects the interrupt request with the highest priority, sends the request to the CPU, and holds other interrupt requests pending.
4. When the CPU accepts the interrupt request, it starts interrupt exception handling after execution of the current instruction has been completed.
5. The PC and CCR contents are saved to the stack area during the interrupt exception handling. The PC contents saved on the stack is the address of the first instruction to be executed after returning from the interrupt handling routine.
6. Next, the I bit in CCR is set to 1. This masks all interrupts except NMI.

7. The CPU generates a vector address for the accepted interrupt and starts execution of the interrupt handling routine at the address indicated by the contents of the vector address in the vector table.

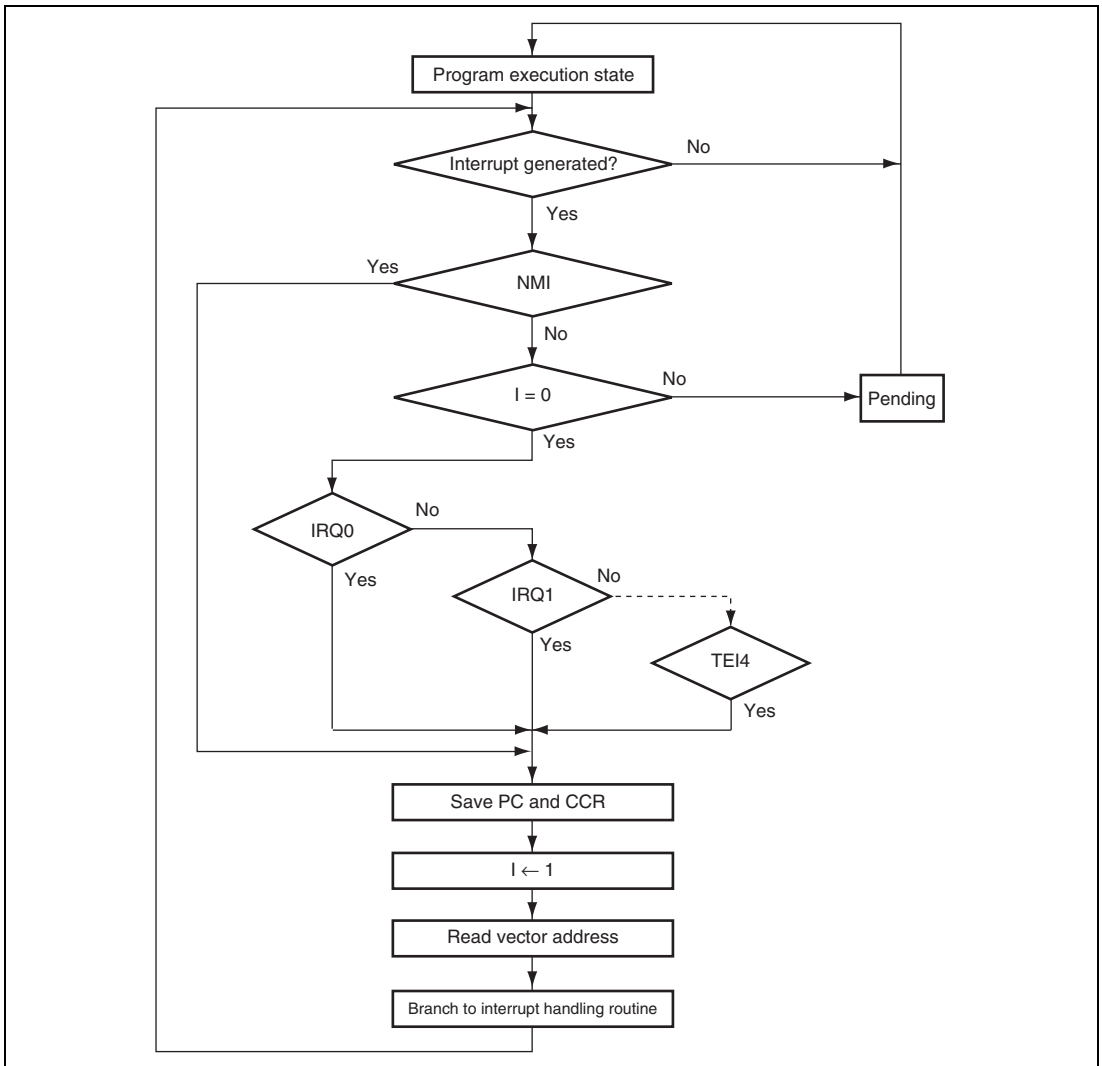

Figure 7.3 Flowchart of Procedure Up to Interrupt Acceptance in Interrupt Control Mode 0

7.6.2 Interrupt Control Mode 2

In interrupt control mode 2, interrupt requests except for NMI are masked by comparing the interrupt mask level (I2 to I0 bits) in EXR of the CPU and the IPR setting. There are eight levels in mask control. Figure 7.4 shows a flowchart of the interrupt acceptance operation in this case.

1. If an interrupt request occurs when the corresponding interrupt enable bit is set to 1, an interrupt request is sent to the interrupt controller.
2. For multiple interrupt requests, the interrupt controller selects the interrupt request with the highest priority according to the IPR setting, and holds other interrupt requests pending. If multiple interrupt requests have the same priority, an interrupt request is selected according to the default setting shown in table 7.2.
3. Next, the priority of the selected interrupt request is compared with the interrupt mask level set in EXR. When the interrupt request does not have priority over the mask level set, it is held pending, and only an interrupt request with a priority over the interrupt mask level is accepted.
4. When the CPU accepts an interrupt request, it starts interrupt exception handling after execution of the current instruction has been completed.
5. The PC, CCR, and EXR contents are saved to the stack area during interrupt exception handling. The PC saved on the stack is the address of the first instruction to be executed after returning from the interrupt handling routine.
6. The T bit in EXR is cleared to 0. The interrupt mask level is rewritten with the priority of the accepted interrupt. If the accepted interrupt is NMI, the interrupt mask level is set to H'7.
7. The CPU generates a vector address for the accepted interrupt and starts execution of the interrupt handling routine at the address indicated by the contents of the vector address in the vector table.

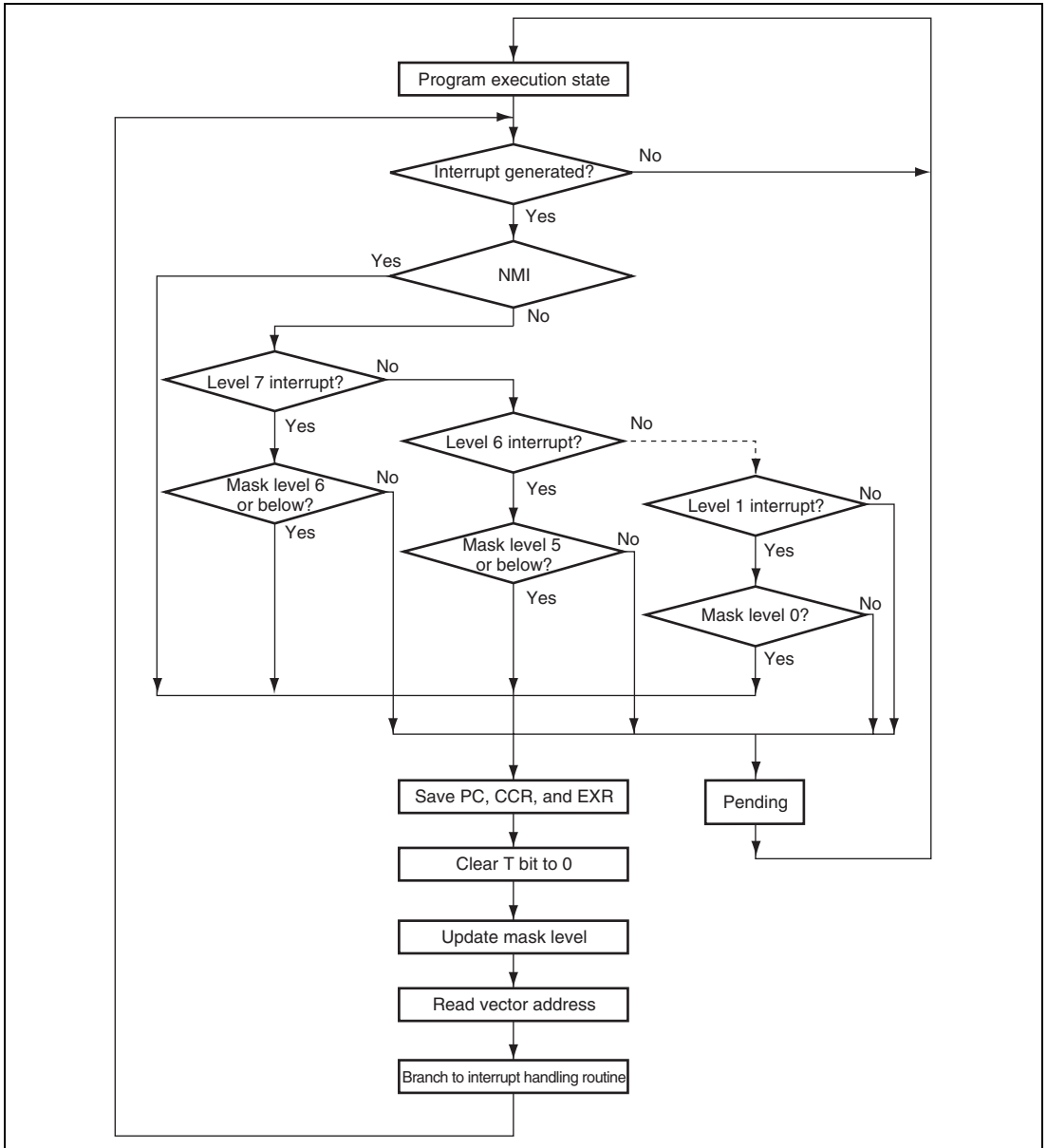

Figure 7.4 Flowchart of Procedure Up to Interrupt Acceptance in Interrupt Control Mode 2

7.6.3 Interrupt Exception Handling Sequence

Figure 7.5 shows the interrupt exception handling sequence. The example is for the case where interrupt control mode 0 is set in maximum mode, and the program area and stack area are in on-chip memory.

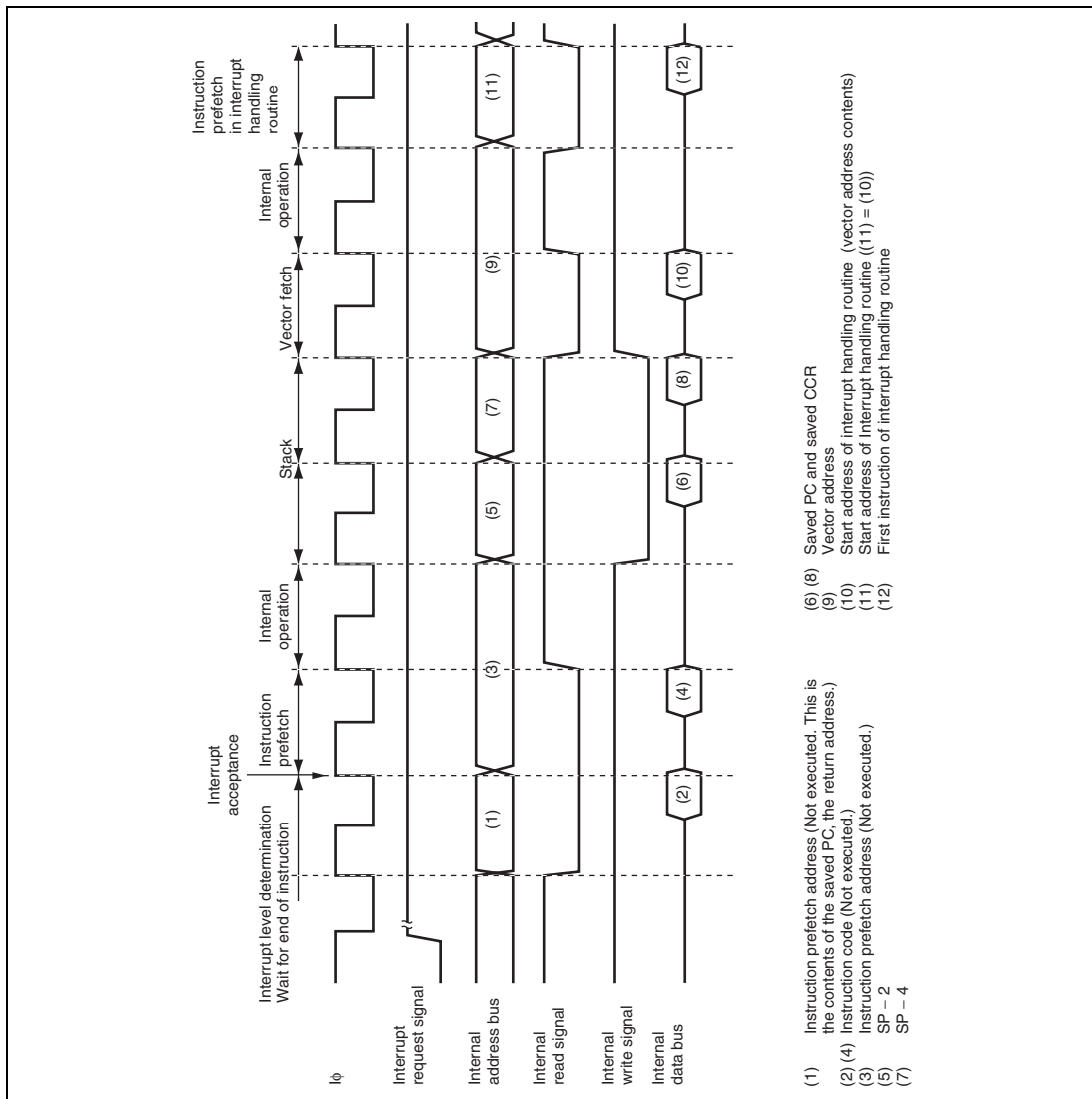

Figure 7.5 Interrupt Exception Handling

7.6.4 Interrupt Response Times

Table 7.4 shows interrupt response times – the interval between generation of an interrupt request and execution of the first instruction in the interrupt handling routine. The symbols for execution states used in table 7.4 are explained in table 7.5.

This LSI is capable of fast word transfer to on-chip memory, so allocating the program area in on-chip ROM and the stack area in on-chip RAM enables high-speed processing.

Table 7.4 Interrupt Response Times

Execution State	Normal Mode* ⁵		Advanced Mode		Maximum Mode* ⁵	
	Interrupt Control Mode 0	Interrupt Control Mode 2	Interrupt Control Mode 0	Interrupt Control Mode 2	Interrupt Control Mode 0	Interrupt Control Mode 2
Interrupt priority determination* ¹				3		
Number of states until executing instruction ends* ²				1 to 19 + 2·S _i		
PC, CCR, EXR stacking	S _K to 2·S _K * ⁶	2·S _K	S _K to 2·S _K * ⁶	2·S _K	2·S _K	2·S _K
Vector fetch				S _n		
Instruction fetch* ³				2·S _i		
Internal processing* ⁴				2		
Total (using on-chip memory)	10 to 31	11 to 31	10 to 31	11 to 31	11 to 31	11 to 31

- Notes:
- Two states for an internal interrupt.
 - In the case of the MULXS or DIVXS instruction
 - Prefetch after interrupt acceptance or for an instruction in the interrupt handling routine.
 - Internal operation after interrupt acceptance or after vector fetch
 - Not available in this LSI.
 - When setting the SP value to 4n, the interrupt response time is S_K; when setting to 4n + 2, the interrupt response time is 2·S_K.

Table 7.5 Number of Execution States in Interrupt Handling Routine

Symbol	On-Chip Memory	Object of Access			
		External Device			
		8-Bit Bus		16-Bit Bus	
		2-State Access	3-State Access	2-State Access	3-State Access
Vector fetch S_h	1	8	$12 + 4m$	4	$6 + 2m$
Instruction fetch S_i	1	4	$6 + 2m$	2	$3 + m$
Stack manipulation S_x	1	8	$12 + 4m$	4	$6 + 2m$

[Legend]

m: Number of wait cycles in an external device access.

7.6.5 DTC and DMAC Activation by Interrupt

The DTC and DMAC can be activated by an interrupt. In this case, the following options are available:

- Interrupt request to the CPU
- Activation request to the DTC
- Activation request to the DMAC
- Combination of the above

For details on interrupt requests that can be used to activate the DTC and DMAC, see table 7.2, section 10, DMA Controller (DMAC), and section 11, Data Transfer Controller (DTC).

Figure 7.6 shows a block diagram of the DTC, DMAC, and interrupt controller.

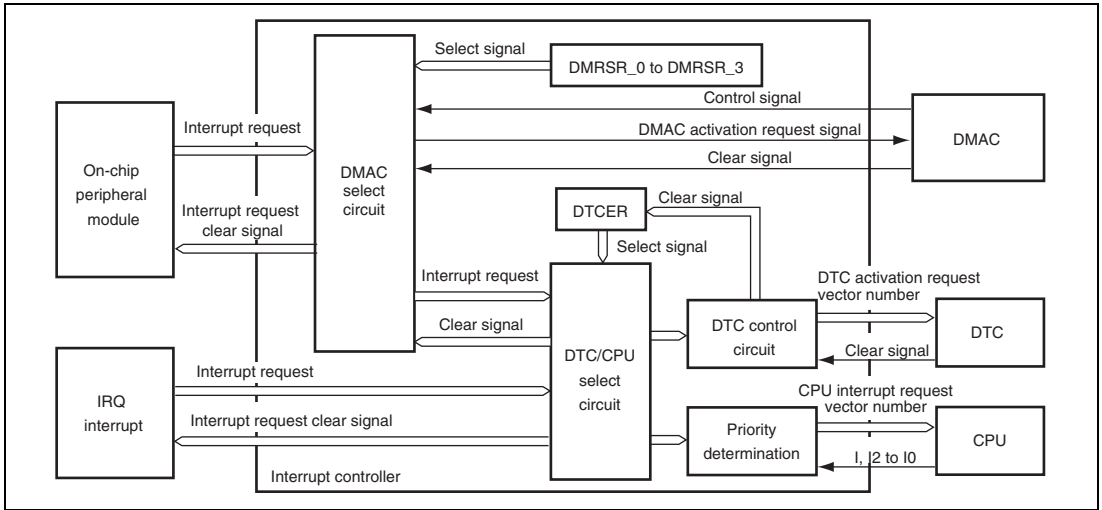

Figure 7.6 Block Diagram of DTC, DMAC, and Interrupt Controller

(1) Selection of Interrupt Sources

The activation source for each DMAC channel is selected by DMRSR. The selected activation source is input to the DMAC through the select circuit. When transfer by an on-chip module interrupt is enabled ($DTF1 = 1$, $DTF0 = 0$, and $DTE = 1$ in DMDR) and the DTA bit in DMDR is set to 1, the interrupt source selected for the DMAC activation source is controlled by the DMAC and cannot be used as a DTC activation source or CPU interrupt source.

Interrupt sources that are not controlled by the DMAC are set for DTC activation sources or CPU interrupt sources by the DTCE bit in DTCERA to DTCERH of the DTC.

Specifying the DISEL bit in MRB of the DTC generates an interrupt request to the CPU by clearing the DTCE bit to 0 after the individual DTC data transfer.

Note that when the DTC performs a predetermined number of data transfers and the transfer counter indicates 0, an interrupt request is made to the CPU by clearing the DTCE bit to 0 after the DTC data transfer.

When the same interrupt source is set as both the DTC and DMAC activation source and CPU interrupt source, the DTC and DMAC must be given priority over the CPU. If the IPSETE bit in CPUPCR is set to 1, the priority is determined according to the IPR setting. Therefore, the CPUP setting or the IPR setting corresponding to the interrupt source must be set to lower than or equal to the DTCP and DMAP setting. If the CPU is given priority over the DTC or DMAC, the DTC or DMAC may not be activated, and the data transfer may not be performed.

(2) Priority Determination

The DTC activation source is selected according to the default priority, and the selection is not affected by its mask level or priority level. For respective priority levels, see table 11.1, Interrupt Sources, DTC Vector Addresses, and Corresponding DTCEs.

(3) Operation Order

If the same interrupt is selected as both the DTC activation source and CPU interrupt source, the CPU interrupt exception handling is performed after the DTC data transfer. If the same interrupt is selected as the DTC or DMAC activation source or CPU interrupt source, respective operations are performed independently.

Table 7.6 lists the selection of interrupt sources and interrupt source clear control by setting the DTA bit in DMDR of the DMAC, the DTCE bit in DTCERA to DTCERH of the DTC, and the DISEL bit in MRB of the DTC.

Table 7.6 Interrupt Source Selection and Clear Control

DMAC Setting DTA	DTC Setting		Interrupt Source Selection/Clear Control		
	DTCE	DISEL	DMAC	DTC	CPU
0	0	*	O	X	√
	1	0	O	√	X
		1	O	O	√
1	*	*	√	X	X

[Legend]

- √: The corresponding interrupt is used. The interrupt source is cleared.
(The interrupt source flag must be cleared in the CPU interrupt handling routine.)
- O: The corresponding interrupt is used. The interrupt source is not cleared.
- X: The corresponding interrupt is not available.
- *: Don't care.

(4) Usage Note

The interrupt sources of the SCI, and A/D converter are cleared according to the setting shown in table 7.6, when the DTC or DMAC reads/writes the prescribed register.

To initiate multiple channels for the DTC with the same interrupt, the same priority (DTCP = DMAP) should be assigned.

7.7 CPU Priority Control Function Over DTC and DMAC

The interrupt controller has a function to control the priority among the DTC, DMAC, and the CPU by assigning different priority levels to the DTC, DMAC, and CPU. Since the priority level can automatically be assigned to the CPU on an interrupt occurrence, it is possible to execute the CPU interrupt exception handling prior to the DTC or DMAC transfer.

The priority level of the CPU is assigned by bits CPUP2 to CPUP0 in CPUPCR. The priority level of the DTC is assigned by bits DTCP2 to DTCP0 in CPUPCR. The priority level of the DMAC is assigned by bits DMAP2 to DMAP0 in DMDR for each channel.

The priority control function over the DTC and DMAC is enabled by setting the CPUPCE bit in CPUPCR to 1. When the CPUPCE bit is 1, the DTC and DMAC activation sources are controlled according to the respective priority levels.

The DTC activation source is controlled according to the priority level of the CPU indicated by bits CPUP2 to CPUP0 and the priority level of the DTC indicated by bits DTCP2 to DTCP0. If the CPU has priority, the DTC activation source is held. The DTC is activated when the condition by which the activation source is held is cancelled (CPUPCE = 1 and value of bits CPUP2 to CPUP0 is greater than that of bits DTCP2 to DTCP0). The priority level of the DTC is assigned by the DTCP2 to DTCP0 bits regardless of the activation source.

For the DMAC, the priority level can be specified for each channel. The DMAC activation source is controlled according to the priority level of each DMAC channel indicated by bits DMAP2 to DMAP0 and the priority level of the CPU. If the CPU has priority, the DMAC activation source is held. The DMAC is activated when the condition by which the activation source is held is cancelled (CPUPCE = 1 and value of bits CPUP2 to CPUP0 is greater than that of bits DMAP2 to DMAP0). If different priority levels are specified for channels, the channels of the higher priority levels continue transfer and the activation sources for the channels of lower priority levels than that of the CPU are held.

There are two methods for assigning the priority level to the CPU by the IPSETE bit in CPUPCR. Setting the IPSETE bit to 1 enables a function to automatically assign the value of the interrupt mask bit of the CPU to the CPU priority level. Clearing the IPSETE bit to 0 disables the function to automatically assign the priority level. Therefore, the priority level is assigned directly by software rewriting bits CPUP2 to CPUP0. Even if the IPSETE bit is 1, the priority level of the CPU is software assignable by rewriting the interrupt mask bit of the CPU (I bit in CCR or I2 to I0 bits in EXR).

The priority level which is automatically assigned when the IPSETE bit is 1 differs according to the interrupt control mode.

In interrupt control mode 0, the I bit in CCR of the CPU is reflected in bit CPUP2. Bits CPUP1 and CPUP0 are fixed 0. In interrupt control mode 2, the values of bits I2 to I0 in EXR of the CPU are reflected in bits CPUP2 to CPUP0.

Table 7.7 shows the CPU priority control.

Table 7.7 CPU Priority Control

Interrupt Control Mode	Interrupt Priority	Interrupt Mask Bit	IPSETE in CPUPCR	Control Status	
				CPUP2 to CPUP0	Updating of CPUP2 to CPUP0
0	Default	I = any	0	B'111 to B'000	Enabled
		I = 0	1	B'000	Disabled
		I = 1		B'100	
2	IPR setting	I2 to I0	0	B'111 to B'000	Enabled
			1	I2 to I0	Disabled

Table 7.8 shows a setting example of the priority control function over the DTC and DMAC and the transfer request control state. A priority level can be independently set to each DMAC channel, but the table only shows one channel for example. Transfers through the DMAC channels can be separately controlled by assigning different priority levels for channels.

Table 7.8 Example of Priority Control Function Setting and Control State

Interrupt Control Mode	CPUPCE in CPUPCR	CPUP2 to CPUP0	DTCP2 to DTCP0	DMAP2 to DMAP0	Transfer Request Control State	
					DTC	DMAC
0	0	Any	Any	Any	Enabled	Enabled
	1	B'000	B'000	B'000	Enabled	Enabled
		B'100	B'000	B'000	Masked	Masked
		B'100	B'000	B'011	Masked	Masked
		B'100	B'111	B'101	Enabled	Enabled
		B'000	B'111	B'101	Enabled	Enabled
2	0	Any	Any	Any	Enabled	Enabled
	1	B'000	B'000	B'000	Enabled	Enabled
		B'000	B'011	B'101	Enabled	Enabled
		B'011	B'011	B'101	Enabled	Enabled
		B'100	B'011	B'101	Masked	Enabled
		B'101	B'011	B'101	Masked	Enabled
		B'110	B'011	B'101	Masked	Masked
		B'111	B'011	B'101	Masked	Masked
		B'101	B'011	B'101	Masked	Enabled
		B'101	B'110	B'101	Enabled	Enabled

7.8 Usage Notes

7.8.1 Conflict between Interrupt Generation and Disabling

When an interrupt enable bit is cleared to 0 to mask the interrupt, the masking becomes effective after execution of the instruction.

When an interrupt enable bit is cleared to 0 by an instruction such as BCLR or MOV, if an interrupt is generated during execution of the instruction, the interrupt concerned will still be enabled on completion of the instruction, and so interrupt exception handling for that interrupt will be executed on completion of the instruction. However, if there is an interrupt request with priority over that interrupt, interrupt exception handling will be executed for the interrupt with priority, and another interrupt will be ignored. The same also applies when an interrupt source flag is cleared to 0. Figure 7.7 shows an example in which the TCIEV bit in TIER of the TPU is cleared to 0. The above conflict will not occur if an enable bit or interrupt source flag is cleared to 0 while the interrupt is masked.

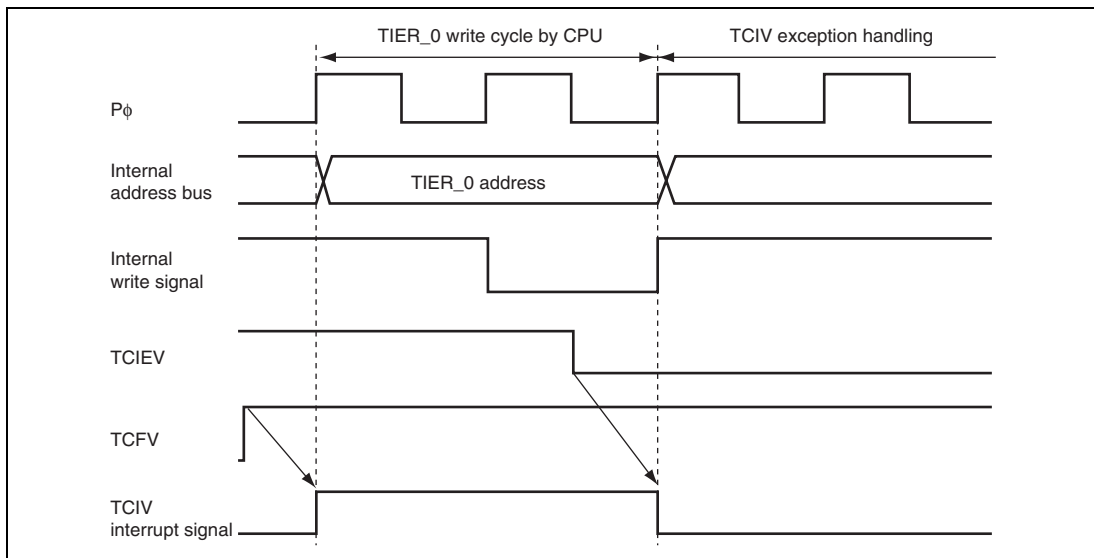

Figure 7.7 Conflict between Interrupt Generation and Disabling

Similarly, when an interrupt is requested immediately before the DTC enable bit is changed to activate the DTC, DTC activation and the interrupt exception handling by the CPU are both executed. When changing the DTC enable bit, make sure that an interrupt is not requested.

7.8.2 Instructions that Disable Interrupts

Instructions that disable interrupts immediately after execution are LDC, ANDC, ORC, and XORC. After any of these instructions is executed, all interrupts including NMI are disabled and the next instruction is always executed. When the I bit is set by one of these instructions, the new value becomes valid two states after execution of the instruction ends.

7.8.3 Times when Interrupts are Disabled

There are times when interrupt acceptance is disabled by the interrupt controller.

The interrupt controller disables interrupt acceptance for a 3-state period after the CPU has updated the mask level with an LDC, ANDC, ORC, or XORC instruction, and for a period of writing to the registers of the interrupt controller.

7.8.4 Interrupts during Execution of EEPMOV Instruction

Interrupt operation differs between the EEPMOV.B and the EEPMOV.W instructions.

With the EEPMOV.B instruction, an interrupt request (including NMI) issued during the transfer is not accepted until the transfer is completed.

With the EEPMOV.W instruction, if an interrupt request is issued during the transfer, interrupt exception handling starts at the end of the individual transfer cycle. The PC value saved on the stack in this case is the address of the next instruction. Therefore, if an interrupt is generated during execution of an EEPMOV.W instruction, the following coding should be used.

```
L1:    EEPMOV.W  
      MOV.W  R4, R4  
      BNE   L1
```

7.8.5 Interrupts during Execution of MOVMD and MOVSD Instructions

With the MOVMD or MOVSD instruction, if an interrupt request is issued during the transfer, interrupt exception handling starts at the end of the individual transfer cycle. The PC value saved on the stack in this case is the address of the MOVMD or MOVSD instruction. The transfer of the remaining data is resumed after returning from the interrupt handling routine.

7.8.6 Interrupts of Peripheral Modules

To clear an interrupt source flag by the CPU using an interrupt function of a peripheral module, the flag must be read from after clearing within the interrupt processing routine. This makes the request signal synchronized with the peripheral module clock. For details, refer to section 24.5.1, Notes on Clock Pulse Generator.

Section 8 User Break Controller (UBC)

The user break controller (UBC) generates a UBC break interrupt request each time the state of the program counter matches a specified break condition. The UBC break interrupt is a non-maskable interrupt and is always accepted, regardless of the interrupt control mode and the state of the interrupt mask bit of the CPU.

For each channel, the break control register (BRCR) and break address register (BAR) are used to specify the break condition as a combination of address bits and type of bus cycle.

Four break conditions are independently specifiable on four channels, A to D.

8.1 Features

- Number of break channels: four (channels A, B, C, and D)
- Break comparison conditions (each channel)
 - Address
 - Bus master (CPU cycle)
 - Bus cycle (instruction execution (PC break))
- UBC break interrupt exception handling is executed immediately before execution of the instruction fetched from the specified address (PC break).
- Module stop state can be set

8.2 Block Diagram

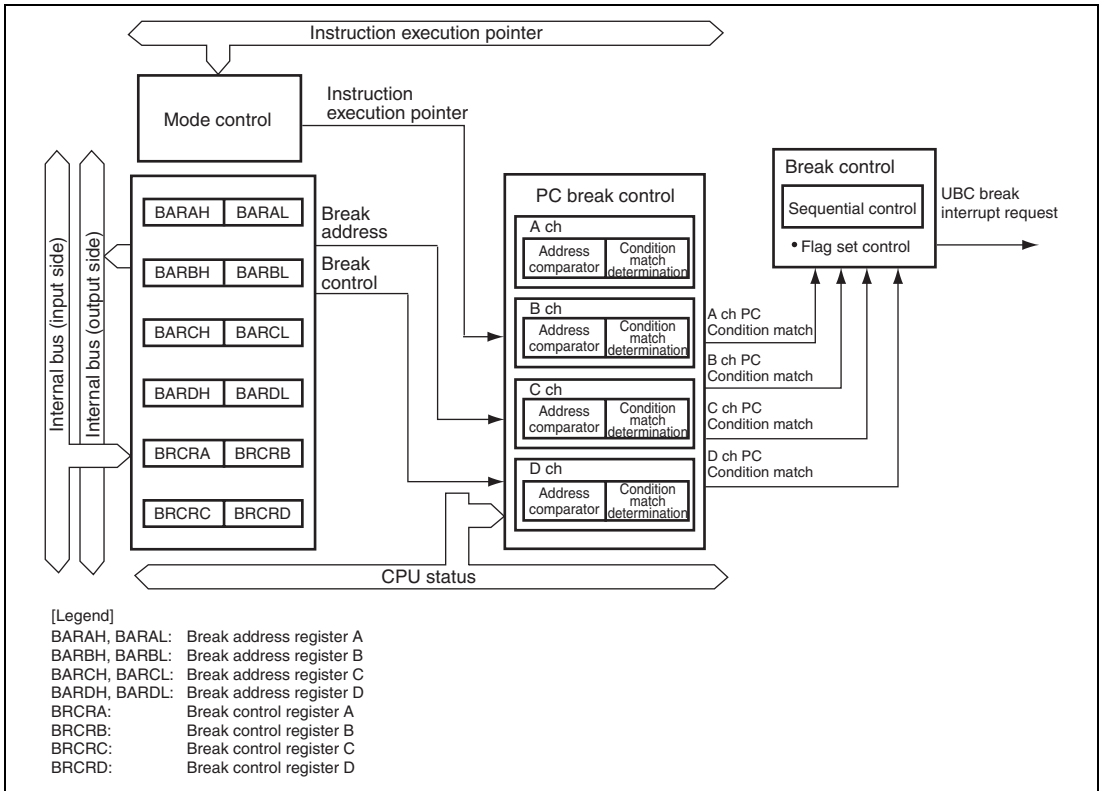

Figure 8.1 Block Diagram of UBC

8.3 Register Descriptions

Table 8.1 lists the register configuration of the UBC.

Table 8.1 Register Configuration

Register Name	Abbreviation	R/W	Initial Value	Address	Access Size
Break address register A	BARAH	R/W	H'0000	H'FFA00	16
	BARAL	R/W	H'0000	H'FFA02	16
Break address mask register A	BAMRAH	R/W	H'0000	H'FFA04	16
	BAMRAL	R/W	H'0000	H'FFA06	16
Break address register B	BARBH	R/W	H'0000	H'FFA08	16
	BARBL	R/W	H'0000	H'FFA0A	16
Break address mask register B	BAMRBH	R/W	H'0000	H'FFA0C	16
	BAMRBL	R/W	H'0000	H'FFA0E	16
Break address register C	BARCH	R/W	H'0000	H'FFA10	16
	BARCL	R/W	H'0000	H'FFA12	16
Break address mask register C	BAMRCH	R/W	H'0000	H'FFA14	16
	BAMRCL	R/W	H'0000	H'FFA16	16
Break address register D	BARDH	R/W	H'0000	H'FFA18	16
	BARDL	R/W	H'0000	H'FFA1A	16
Break address mask register D	BAMRDH	R/W	H'0000	H'FFA1C	16
	BAMRDL	R/W	H'0000	H'FFA1E	16
Break control register A	BRCRA	R/W	H'0000	H'FFA28	8/16
Break control register B	BRCRB	R/W	H'0000	H'FFA2C	8/16
Break control register C	BRCRC	R/W	H'0000	H'FFA30	8/16
Break control register D	BRCRD	R/W	H'0000	H'FFA34	8/16

8.3.1 Break Address Register n (BARA, BARB, BARC, BARD)

Each break address register n (BARn) consists of break address register nH (BARnH) and break address register nL (BARnL). Together, BARnH and BARnL specify the address used as a break condition on channel n of the UBC.

BARnH

Bit:	31	30	29	28	27	26	25	24	23	22	21	20	19	18	17	16
	BARn31	BARn30	BARn29	BARn28	BARn27	BARn26	BARn25	BARn24	BARn23	BARn22	BARn21	BARn20	BARn19	BARn18	BARn17	BARn16
Initial Value:	0	0	0	0	0	0	0	0	0	0	0	0	0	0	0	0
R/W:	R/W	R/W	R/W	R/W	R/W	R/W	R/W	R/W	R/W	R/W	R/W	R/W	R/W	R/W	R/W	R/W

BARnL

Bit:	15	14	13	12	11	10	9	8	7	6	5	4	3	2	1	0
	BARn15	BARn14	BARn13	BARn12	BARn11	BARn10	BARn9	BARn8	BARn7	BARn6	BARn5	BARn4	BARn3	BARn2	BARn1	BARn0
Initial Value:	0	0	0	0	0	0	0	0	0	0	0	0	0	0	0	0
R/W:	R/W	R/W	R/W	R/W	R/W	R/W	R/W	R/W	R/W	R/W	R/W	R/W	R/W	R/W	R/W	R/W

- BARnH

Bit	Bit Name	Initial Value	R/W	Description
31 to 16	BARn31 to BARn16	All 0	R/W	Break Address n31 to 16 These bits hold the upper bit values (bits 31 to 16) for the address break-condition on channel n.

[Legend]

n = Channels A to D

- BARnL

Bit	Bit Name	Initial Value	R/W	Description
15 to 0	BARn15 to BARn0	All 0	R/W	Break Address n15 to 0 These bits hold the lower bit values (bits 15 to 0) for the address break-condition on channel n.

[Legend]

n = Channels A to D

8.3.2 Break Address Mask Register n (BAMRA, BAMRB, BAMRC, BAMRD)

Be sure to write H'FF00 0000 to break address mask register n (BAMRn). Operation is not guaranteed if another value is written here.

BAMRnH

Bit:	31	30	29	28	27	26	25	24	23	22	21	20	19	18	17	16
	BAMRn31	BAMRn30	BAMRn29	BAMRn28	BAMRn27	BAMRn26	BAMRn25	BAMRn24	BAMRn23	BAMRn22	BAMRn21	BAMRn20	BAMRn19	BAMRn18	BAMRn17	BAMRn16
Initial Value:	0	0	0	0	0	0	0	0	0	0	0	0	0	0	0	0
R/W:	R/W	R/W	R/W	R/W	R/W	R/W	R/W	R/W	R/W	R/W	R/W	R/W	R/W	R/W	R/W	R/W

BAMRnL

Bit:	15	14	13	12	11	10	9	8	7	6	5	4	3	2	1	0
	BAMRn15	BAMRn14	BAMRn13	BAMRn12	BAMRn11	BAMRn10	BAMRn9	BAMRn8	BAMRn7	BAMRn6	BAMRn5	BAMRn4	BAMRn3	BAMRn2	BAMRn1	BAMRn0
Initial Value:	0	0	0	0	0	0	0	0	0	0	0	0	0	0	0	0
R/W:	R/W	R/W	R/W	R/W	R/W	R/W	R/W	R/W	R/W	R/W	R/W	R/W	R/W	R/W	R/W	R/W

- BAMRnH

Bit	Bit Name	Initial Value	R/W	Description
31 to 16	BAMRn31 to BAMRn16	All 0	R/W	Break Address Mask n31 to 16 Be sure to write H'FF00 here before setting a break condition in the break control register.

[Legend]

n = Channels A to D

- BAMRnL

Bit	Bit Name	Initial Value	R/W	Description
15 to 0	BAMRn15 to BAMRn0	All 0	R/W	Break Address Mask n15 to 0 Be sure to write H'0000 here before setting a break condition in the break control register.

[Legend]

n = Channels A to D

8.3.3 Break Control Register n (BRCRA, BRCRB, BRCRC, BRCRD)

BRCRA, BRCRB, BRCRC, and BRCRD are used to specify and control conditions for channels A, B, C, and D of the UBC.

Bit:	15	14	13	12	11	10	9	8	7	6	5	4	3	2	1	0
	—	—	CMFCPn	—	CPn2	CPn1	CPn0	—	—	—	IDn1	IDn0	RWn1	RWn0	—	—
Initial Value:	0	0	0	0	0	0	0	0	0	0	0	0	0	0	0	0
R/W:	R/W	R/W	R/W	R/W	R/W	R/W	R/W	R/W	R/W	R/W	R/W	R/W	R/W	R/W	R/W	R/W

[Legend]
n = Channels A to D

Bit	Bit Name	Initial Value	R/W	Description
15	—	0	R/W	Reserved
14	—	0	R/W	These bits are always read as 0. The write value should always be 0.
13	CMFCPn	0	R/W	Condition Match CPU Flag UBC break source flag that indicates satisfaction of a specified CPU bus cycle condition. 0: The CPU cycle condition for channel n break requests has not been satisfied. 1: The CPU cycle condition for channel n break requests has been satisfied.
12	—	0	R/W	Reserved These bits are always read as 0. The write value should always be 0.
11	CPn2	0	R/W	CPU Cycle Select
10	CPn1	0	R/W	These bits select CPU cycles as the bus cycle break condition for the given channel.
9	CPn0	0	R/W	000: Break requests will not be generated. 001: The bus cycle break condition is CPU cycles. 01x: Setting prohibited 1xx: Setting prohibited
8	—	0	R/W	Reserved
7	—	0	R/W	These bits are always read as 0. The write value should always be 0.
6	—	0	R/W	

Bit	Bit Name	Initial Value	R/W	Description
5	IDn1	0	R/W	Break Condition Select
4	IDn0	0	R/W	These bits select the PC break as the source of UBC break interrupt requests for the given channel. 00: Break requests will not be generated. 01: UBC break condition is the PC break. 1x: Setting prohibited
3	RWn1	0	R/W	Read Select
2	RWn0	0	R/W	These bits select read cycles as the bus cycle break condition for the given channel. 00: Break requests will not be generated. 01: The bus cycle break condition is read cycles. 1x: Setting prohibited
1	—	0	R/W	Reserved
0	—	0	R/W	These bits are always read as 0. The write value should always be 0.

[Legend]

n = Channels A to D

8.4 Operation

The UBC does not detect condition matches in standby states (sleep mode, all module clock stop mode, software standby mode, deep software standby mode, and hardware standby mode).

8.4.1 Setting of Break Control Conditions

1. The address condition for the break is set in break address register n (BARn). A mask for the address is set in break address mask register n (BAMRn).
2. The bus and break conditions are set in break control register n (BRCRn). Bus conditions consist of CPU cycle, PC break, and reading. Condition comparison is not performed when the CPU cycle setting is CPn = B'000, the PC break setting is IDn = B'00, or the read setting is RWn = B'00.
3. The condition match CPU flag (CMFCPn) is set in the event of a break condition match on the corresponding channel. These flags are set when the break condition matches but are not cleared when it no longer does. To confirm setting of the same flag again, read the flag once from the break interrupt handling routine, and then write 0 to it (the flag is cleared by writing 0 to it after reading it as 1).

[Legend]

n = Channels A to D

8.4.2 PC Break

1. When specifying a PC break, specify the address as the first address of the required instruction. If the address for a PC break condition is not the first address of an instruction, a break will never be generated.
2. The break occurs after fetching and execution of the target instruction have been confirmed. In cases of contention between a break before instruction execution and a user maskable interrupt, priority is given to the break before instruction execution.
3. A break will not be generated even if a break before instruction execution is set in a delay slot.
4. The PC break condition is generated by specifying CPU cycles as the bus condition in break control register n (BRCRn.CPn0 = 1), PC break as the break condition (IDn0 = 1), and read cycles as the bus-cycle condition (RWn0 = 1).

[Legend]

n = Channels A to D

8.4.3 Condition Match Flag

Condition match flags are set when the break conditions match. The condition match flags of the UBC are listed in table 8.2.

Table 8.2 List of Condition Match Flags

Register	Flag Bit	Source
BRCRA	CMFCPA (bit 13)	Indicates that the condition matches in the CPU cycle for channel A
BRCRB	CMFCPB (bit 13)	Indicates that the condition matches in the CPU cycle for channel B
BRCRC	CMFCPC (bit 13)	Indicates that the condition matches in the CPU cycle for channel C
BRCRD	CMFCPD (bit 13)	Indicates that the condition matches in the CPU cycle for channel D

8.5 Usage Notes

1. PC break usage note

- Contention between a SLEEP instruction (to place the chip in the sleep state or on software standby) and PC break

If a break before a PC break instruction is set for the instruction after a SLEEP instruction and the SLEEP instruction is executed with the SSBY bit cleared to 0, break interrupt exception handling is executed without sleep mode being entered. In this case, the instruction after the SLEEP instruction is executed after the RTE instruction.

When the SSBY bit is set to 1, break interrupt exception handling is executed after the oscillation settling time has elapsed subsequent to the transition to software standby mode.

When an interrupt is the canceling source, interrupt exception handling is executed after the RTE instruction, and the instruction following the SLEEP instruction is then executed.

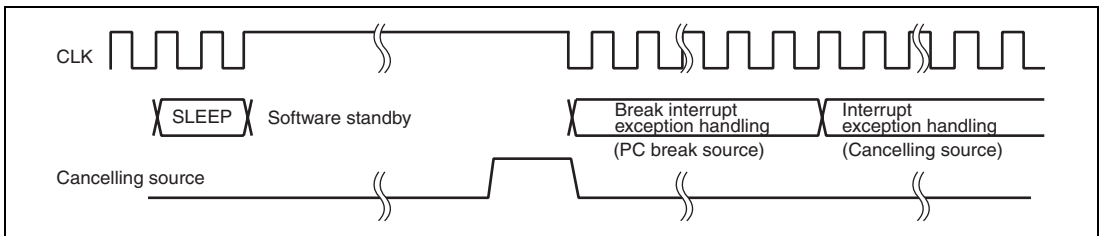

Figure 8.2 Contention between SLEEP Instruction (Software Standby) and PC Break

2. Prohibition on Setting of PC Break

- Setting of a UBC break interrupt for program within the UBC break interrupt handling routine is prohibited.

3. The procedure for clearing a UBC flag bit (condition match flag) is shown below. A flag bit is cleared by writing 0 to it after reading it as 1. As the register that contains the flag bits is accessible in byte units, bit manipulation instructions can be used.

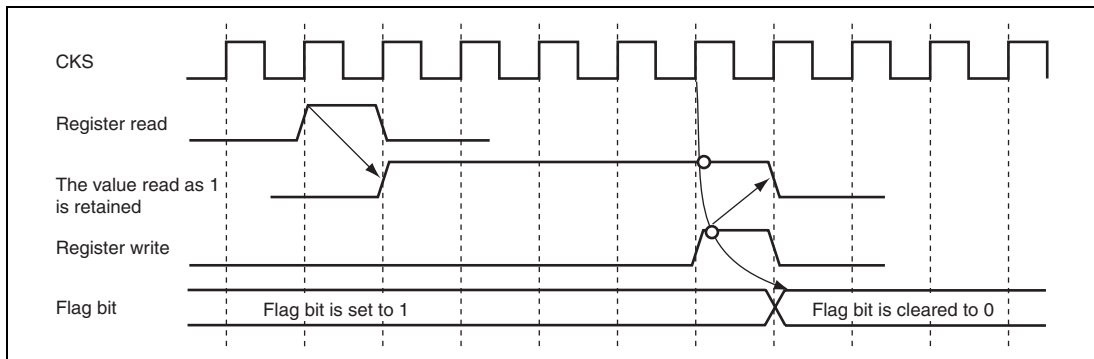

Figure 8.3 Flag Bit Clearing Sequence (Condition Match Flag)

4. If break conditions for the UBC are set, an unexpected UBC break interrupt may occur after the execution of an illegal instruction. This depends on the value of the program counter and the internal bus cycle.

Section 9 Bus Controller (BSC)

This LSI has an on-chip bus controller (BSC) that manages the external address space divided into eight areas.

The bus controller also has a bus arbitration function, and controls the operation of the internal bus masters; CPU, DMAC, and DTC.

9.1 Features

- Manages external address space in area units
 Manages the external address space divided into eight areas
 Chip select signals ($\overline{CS0}$ to $\overline{CS7}$) can be output for each area
 Bus specifications can be set independently for each area
 8-bit access or 16-bit access can be selected for each area
 Burst ROM, byte control SRAM, or address/data multiplexed I/O interface can be set
 An endian conversion function is provided to connect a device of little endian
- Basic bus interface
 This interface can be connected to the SRAM and ROM
 2-state access or 3-state access can be selected for each area
 Program wait cycles can be inserted for each area
 Wait cycles can be inserted by the \overline{WAIT} pin.
 Extension cycles can be inserted while \overline{CSn} is asserted for each area (n = 0 to 7)
 The negation timing of the read strobe signal (\overline{RD}) can be modified
- Byte control SRAM interface
 Byte control SRAM interface can be set for areas 0 to 7
 The SRAM that has a byte control pin can be directly connected
- Burst ROM interface
 Burst ROM interface can be set for areas 0 and 1
 Burst ROM interface parameters can be set independently for areas 0 and 1
- Address/data multiplexed I/O interface
 Address/data multiplexed I/O interface can be set for areas 3 to 7

- Idle cycle insertion

Idle cycles can be inserted between external read accesses to different areas

Idle cycles can be inserted before the external write access after an external read access

Idle cycles can be inserted before the external read access after an external write access

Idle cycles can be inserted before the external access after a DMAC single address transfer (write access)

- Write buffer function

External write cycles and internal accesses can be executed in parallel

Write accesses to the on-chip peripheral module and on-chip memory accesses can be executed in parallel

DMAC single address transfers and internal accesses can be executed in parallel

- External bus release function

- Bus arbitration function

Includes a bus arbiter that arbitrates bus mastership among the CPU, DMAC, DTC, and external bus master

- Multi-clock function

The internal peripheral functions can be operated in synchronization with the peripheral module clock ($P\phi$). Accesses to the external address space can be operated in synchronization with the external bus clock ($B\phi$).

- The bus start (\overline{BS}) and read/write (RD/\overline{WR}) signals can be output.

A block diagram of the bus controller is shown in figure 9.1.

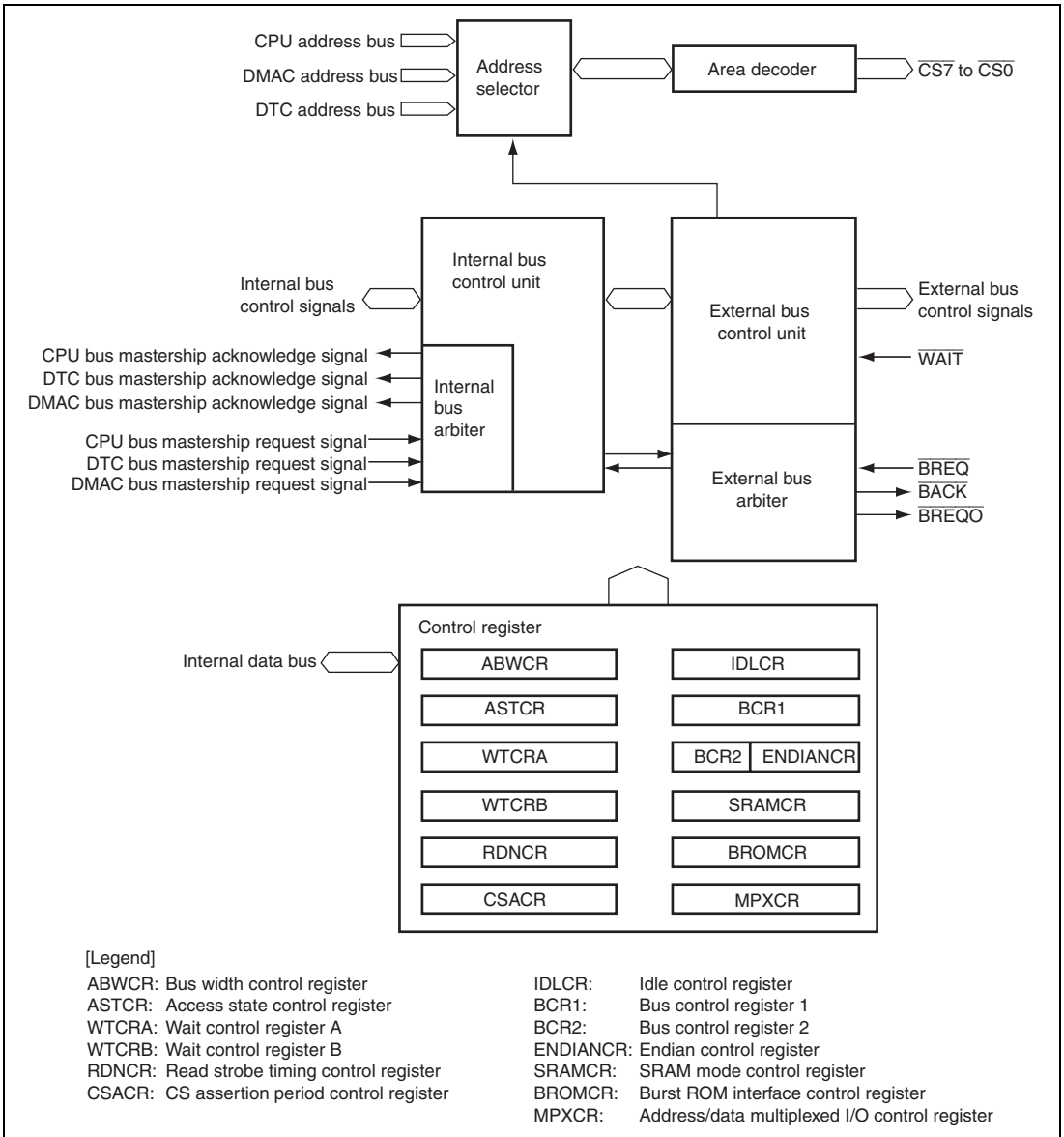

Figure 9.1 Block Diagram of Bus Controller

9.2 Register Descriptions

The bus controller has the following registers.

- Bus width control register (ABWCR)
- Access state control register (ASTCR)
- Wait control register A (WTCRA)
- Wait control register B (WTCRB)
- Read strobe timing control register (RDNCR)
- \overline{CS} assertion period control register (CSACR)
- Idle control register (IDLCR)
- Bus control register 1 (BCR1)
- Bus control register 2 (BCR2)
- Endian control register (ENDIANCR)
- SRAM mode control register (SRAMCR)
- Burst ROM interface control register (BROMCR)
- Address/data multiplexed I/O control register (MPXCR)

9.2.1 Bus Width Control Register (ABWCR)

ABWCR specifies the data bus width for each area in the external address space.

Bit	15	14	13	12	11	10	9	8
Bit Name	ABWH7	ABWH6	ABWH5	ABWH4	ABWH3	ABWH2	ABWH1	ABWH0
Initial Value	1	1	1	1	1	1	1	1/0
R/W	R/W	R/W	R/W	R/W	R/W	R/W	R/W	R/W

Bit	7	6	5	4	3	2	1	0
Bit Name	ABWL7	ABWL6	ABWL5	ABWL4	ABWL3	ABWL2	ABWL1	ABWL0
Initial Value	1	1	1	1	1	1	1	1
R/W	R/W	R/W	R/W	R/W	R/W	R/W	R/W	R/W

Note: * Initial value at 16-bit bus initiation is H'FEFF, and that at 8-bit bus initiation is H'FFFF.

Bit	Bit Name	Initial Value* ¹	R/W	Description
15	ABWH7	1	R/W	Area 7 to 0 Bus Width Control
14	ABWH6	1	R/W	These bits select whether the corresponding area is to be designated as 8-bit access space or 16-bit access space.
13	ABWH5	1	R/W	
12	ABWH4	1	R/W	ABWHn ABWLn (n = 7 to 0)
11	ABWH3	1	R/W	× 0: Setting prohibited
10	ABWH2	1	R/W	0 1: Area n is designated as 16-bit access space
9	ABWH1	1	R/W	1 1: Area n is designated as 8-bit access space* ²
8	ABWL0	1/0	R/W	
7	ABWL7	1	R/W	
6	ABWL6	1	R/W	
5	ABWL5	1	R/W	
4	ABWL4	1	R/W	
3	ABWL3	1	R/W	
2	ABWL2	1	R/W	
1	ABWL1	1	R/W	
0	ABWL0	1	R/W	

[Legend]

×: Don't care

- Notes:
1. Initial value at 16-bit bus initiation is H'FEFF, and that at 8-bit bus initiation is H'FFFF.
 2. An address space specified as byte control SRAM interface must not be specified as 8-bit access space.

9.2.2 Access State Control Register (ASTCR)

ASTCR designates each area in the external address space as either 2-state access space or 3-state access space and enables/disables wait cycle insertion.

Bit	15	14	13	12	11	10	9	8
Bit Name	AST7	AST6	AST5	AST4	AST3	AST2	AST1	AST0
Initial Value	1	1	1	1	1	1	1	1
R/W	R/W	R/W	R/W	R/W	R/W	R/W	R/W	R/W
Bit	7	6	5	4	3	2	1	0
Bit Name	—	—	—	—	—	—	—	—
Initial Value	0	0	0	0	0	0	0	0
R/W	R	R	R	R	R	R	R	R

Bit	Bit Name	Initial Value	R/W	Description
15	AST7	1	R/W	Area 7 to 0 Access State Control
14	AST6	1	R/W	These bits select whether the corresponding area is to be designated as 2-state access space or 3-state access space. Wait cycle insertion is enabled or disabled at the same time.
13	AST5	1	R/W	
12	AST4	1	R/W	0: Area n is designated as 2-state access space Wait cycle insertion in area n access is disabled
11	AST3	1	R/W	
10	AST2	1	R/W	1: Area n is designated as 3-state access space Wait cycle insertion in area n access is enabled
9	AST1	1	R/W	
8	AST0	1	R/W	(n = 7 to 0)
7 to 0	—	All 0	R	Reserved
				These are read-only bits and cannot be modified.

9.2.3 Wait Control Registers A and B (WTCRA, WTCRB)

WTCRA and WTCRB select the number of program wait cycles for each area in the external address space.

• WTCRA

Bit	15	14	13	12	11	10	9	8
Bit Name	—	W72	W71	W70	—	W62	W61	W60
Initial Value	0	1	1	1	0	1	1	1
R/W	R	R/W	R/W	R/W	R	R/W	R/W	R/W
Bit	7	6	5	4	3	2	1	0
Bit Name	—	W52	W51	W50	—	W42	W41	W40
Initial Value	0	1	1	1	0	1	1	1
R/W	R	R/W	R/W	R/W	R	R/W	R/W	R/W

• WTCRB

Bit	15	14	13	12	11	10	9	8
Bit Name	—	W32	W31	W30	—	W22	W21	W20
Initial Value	0	1	1	1	0	1	1	1
R/W	R	R/W	R/W	R/W	R	R/W	R/W	R/W
Bit	7	6	5	4	3	2	1	0
Bit Name	—	W12	W11	W10	—	W02	W01	W00
Initial Value	0	1	1	1	0	1	1	1
R/W	R	R/W	R/W	R/W	R	R/W	R/W	R/W

- WTCRA

Bit	Bit Name	Initial Value	R/W	Description		
15	—	0	R	Reserved This is a read-only bit and cannot be modified.		
14	W72	1	R/W	Area 7 Wait Control 2 to 0		
13	W71	1	R/W	These bits select the number of program wait cycles when accessing area 7 while bit AST7 in ASTCR is 1. 000: Program wait cycle not inserted 001: 1 program wait cycle inserted 010: 2 program wait cycles inserted 011: 3 program wait cycles inserted 100: 4 program wait cycles inserted 101: 5 program wait cycles inserted 110: 6 program wait cycles inserted 111: 7 program wait cycles inserted		
12	W70	1	R/W			
11	—	0	R		Reserved This is a read-only bit and cannot be modified.	
10	W62	1	R/W		Area 6 Wait Control 2 to 0	
9	W61	1	R/W		These bits select the number of program wait cycles when accessing area 6 while bit AST6 in ASTCR is 1. 000: Program wait cycle not inserted 001: 1 program wait cycle inserted 010: 2 program wait cycles inserted 011: 3 program wait cycles inserted 100: 4 program wait cycles inserted 101: 5 program wait cycles inserted 110: 6 program wait cycles inserted 111: 7 program wait cycles inserted	
8	W60	1	R/W			
7	—	0	R			Reserved This is a read-only bit and cannot be modified.

Bit	Bit Name	Initial Value	R/W	Description	
6	W52	1	R/W	Area 5 Wait Control 2 to 0	
5	W51	1	R/W	These bits select the number of program wait cycles when accessing area 5 while bit AST5 in ASTCR is 1. 000: Program cycle wait not inserted 001: 1 program wait cycle inserted 010: 2 program wait cycles inserted 011: 3 program wait cycles inserted 100: 4 program wait cycles inserted 101: 5 program wait cycles inserted 110: 6 program wait cycles inserted 111: 7 program wait cycles inserted	
4	W50	1	R/W		
3	—	0	R		Reserved This is a read-only bit and cannot be modified.
2	W42	1	R/W		Area 4 Wait Control 2 to 0
1	W41	1	R/W		These bits select the number of program wait cycles when accessing area 4 while bit AST4 in ASTCR is 1. 000: Program wait cycle not inserted 001: 1 program wait cycle inserted 010: 2 program wait cycles inserted 011: 3 program wait cycles inserted 100: 4 program wait cycles inserted 101: 5 program wait cycles inserted 110: 6 program wait cycles inserted 111: 7 program wait cycles inserted
0	W40	1	R/W		

- WTCRB

Bit	Bit Name	Initial Value	R/W	Description		
15	—	0	R	Reserved This is a read-only bit and cannot be modified.		
14	W32	1	R/W	Area 3 Wait Control 2 to 0		
13	W31	1	R/W	These bits select the number of program wait cycles when accessing area 3 while bit AST3 in ASTCR is 1. 000: Program wait cycle not inserted 001: 1 program wait cycle inserted 010: 2 program wait cycles inserted 011: 3 program wait cycles inserted 100: 4 program wait cycles inserted 101: 5 program wait cycles inserted 110: 6 program wait cycles inserted 111: 7 program wait cycles inserted		
12	W30	1	R/W			
11	—	0	R		Reserved This is a read-only bit and cannot be modified.	
10	W22	1	R/W		Area 2 Wait Control 2 to 0	
9	W21	1	R/W		These bits select the number of program wait cycles when accessing area 2 while bit AST2 in ASTCR is 1. 000: Program wait cycle not inserted 001: 1 program wait cycle inserted 010: 2 program wait cycles inserted 011: 3 program wait cycles inserted 100: 4 program wait cycles inserted 101: 5 program wait cycles inserted 110: 6 program wait cycles inserted 111: 7 program wait cycles inserted	
8	W20	1	R/W			
7	—	0	R			Reserved This is a read-only bit and cannot be modified.

Bit	Bit Name	Initial Value	R/W	Description	
6	W12	1	R/W	Area 1 Wait Control 2 to 0	
5	W11	1	R/W	These bits select the number of program wait cycles when accessing area 1 while bit AST1 in ASTCR is 1. 000: Program wait cycle not inserted 001: 1 program wait cycle inserted 010: 2 program wait cycles inserted 011: 3 program wait cycles inserted 100: 4 program wait cycles inserted 101: 5 program wait cycles inserted 110: 6 program wait cycles inserted 111: 7 program wait cycles inserted	
4	W10	1	R/W		
3	—	0	R		Reserved This is a read-only bit and cannot be modified.
2	W02	1	R/W		Area 0 Wait Control 2 to 0
1	W01	1	R/W		These bits select the number of program wait cycles when accessing area 0 while bit AST0 in ASTCR is 1. 000: Program wait cycle not inserted 001: 1 program wait cycle inserted 010: 2 program wait cycles inserted 011: 3 program wait cycles inserted 100: 4 program wait cycles inserted 101: 5 program wait cycles inserted 110: 6 program wait cycles inserted 111: 7 program wait cycles inserted
0	W00	1	R/W		

9.2.4 Read Strobe Timing Control Register (RDNCR)

RDNCR selects the negation timing of the read strobe signal (\overline{RD}) when reading the external address spaces specified as a basic bus interface or the address/data multiplexed I/O interface.

Bit	15	14	13	12	11	10	9	8
Bit Name	RDN7	RDN6	RDN5	RDN4	RDN3	RDN2	RDN1	RDN0
Initial Value	0	0	0	0	0	0	0	0
R/W	R/W	R/W	R/W	R/W	R/W	R/W	R/W	R/W
Bit	7	6	5	4	3	2	1	0
Bit Name	—	—	—	—	—	—	—	—
Initial Value	0	0	0	0	0	0	0	0
R/W	R	R	R	R	R	R	R	R

Bit	Bit Name	Initial Value	R/W	Description
15	RDN7	0	R/W	Read Strobe Timing Control
14	RDN6	0	R/W	RDN7 to RDN0 set the negation timing of the read strobe in a corresponding area read access.
13	RDN5	0	R/W	
12	RDN4	0	R/W	As shown in figure 9.2, the read strobe for an area for which the RDNn bit is set to 1 is negated one half-cycle earlier than that for an area for which the RDNn bit is cleared to 0. The read data setup and hold time are also given one half-cycle earlier.
11	RDN3	0	R/W	
10	RDN2	0	R/W	
9	RDN1	0	R/W	0: In an area n read access, the \overline{RD} signal is negated at the end of the read cycle 1: In an area n read access, the \overline{RD} signal is negated one half-cycle before the end of the read cycle (n = 7 to 0)
8	RDN0	0	R/W	
7 to 0	—	All 0	R	Reserved

These are read-only bits and cannot be modified.

- Notes:
1. In an external address space which is specified as byte control SRAM interface, the RDNCR setting is ignored and the same operation when RDNn = 1 is performed.
 2. In an external address space which is specified as burst ROM interface, the RDNCR setting is ignored during CPU read accesses and the same operation when RDNn = 0 is performed.

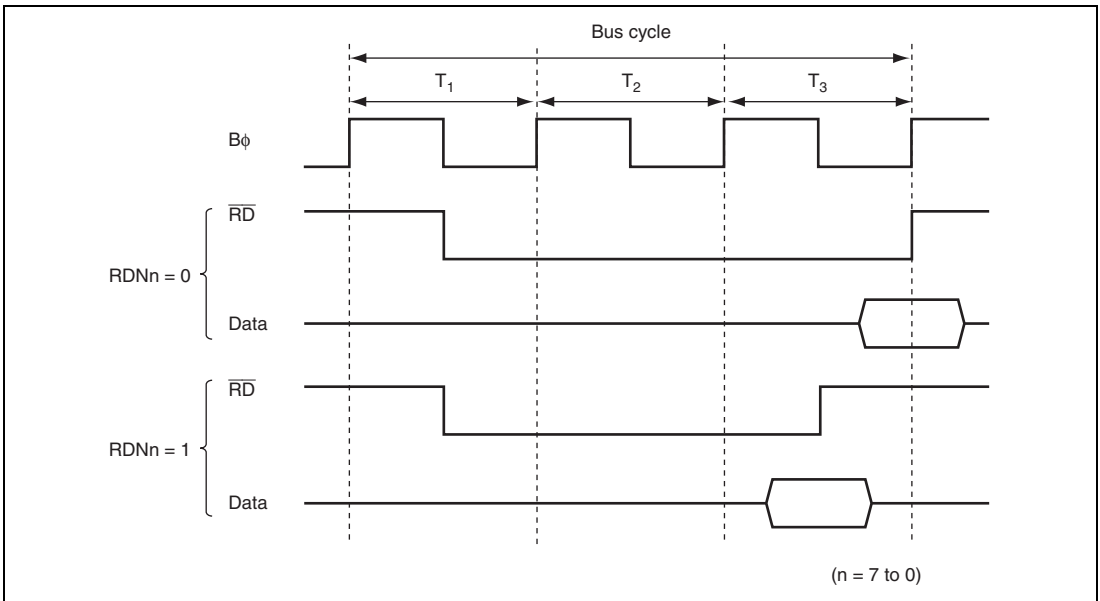

Figure 9.2 Read Strobe Negation Timing (Example of 3-State Access Space)

9.2.5 $\overline{\text{CS}}$ Assertion Period Control Registers (CSACR)

CSACR selects whether or not the assertion periods of the chip select signals ($\overline{\text{CSn}}$) and address signals for the basic bus, byte-control SRAM, burst ROM, and address/data multiplexed I/O interface are to be extended. Extending the assertion period of the $\overline{\text{CSn}}$ and address signals allows the setup time and hold time of read strobe ($\overline{\text{RD}}$) and write strobe ($\overline{\text{LHWR/LLWR}}$) to be assured and to make the write data setup time and hold time for the write strobe become flexible.

Bit	15	14	13	12	11	10	9	8
Bit Name	CSXH7	CSXH6	CSXH5	CSXH4	CSXH3	CSXH2	CSXH1	CSXH0
Initial Value	0	0	0	0	0	0	0	0
R/W	R/W	R/W	R/W	R/W	R/W	R/W	R/W	R/W
Bit	7	6	5	4	3	2	1	0
Bit Name	CSXT7	CSXT6	CSXT5	CSXT4	CSXT3	CSXT2	CSXT1	CSXT0
Initial Value	0	0	0	0	0	0	0	0
R/W	R/W	R/W	R/W	R/W	R/W	R/W	R/W	R/W

Bit	Bit Name	Initial Value	R/W	Description
15	CSXH7	0	R/W	\overline{CS} and Address Signal Assertion Period Control 1
14	CSXH6	0	R/W	These bits specify whether or not the Th cycle is to be inserted (see figure 9.3). When an area for which bit CSXHn is set to 1 is accessed, one Th cycle, in which the \overline{CSn} and address signals are asserted, is inserted before the normal access cycle.
13	CSXH5	0	R/W	
12	CSXH4	0	R/W	
11	CSXH3	0	R/W	
10	CSXH2	0	R/W	
9	CSXH1	0	R/W	
8	CSXH0	0	R/W	
(n = 7 to 0)				
7	CSXT7	0	R/W	\overline{CS} and Address Signal Assertion Period Control 2
6	CSXT6	0	R/W	These bits specify whether or not the Tt cycle is to be inserted (see figure 9.3). When an area for which bit CSXTn is set to 1 is accessed, one Tt cycle, in which the \overline{CSn} and address signals are retained, is inserted after the normal access cycle.
5	CSXT5	0	R/W	
4	CSXT4	0	R/W	
3	CSXT3	0	R/W	
2	CSXT2	0	R/W	
1	CSXT1	0	R/W	
0	CSXT0	0	R/W	
(n = 7 to 0)				

Note: * In burst ROM interface, the CSXTn settings are ignored during CPU read accesses.

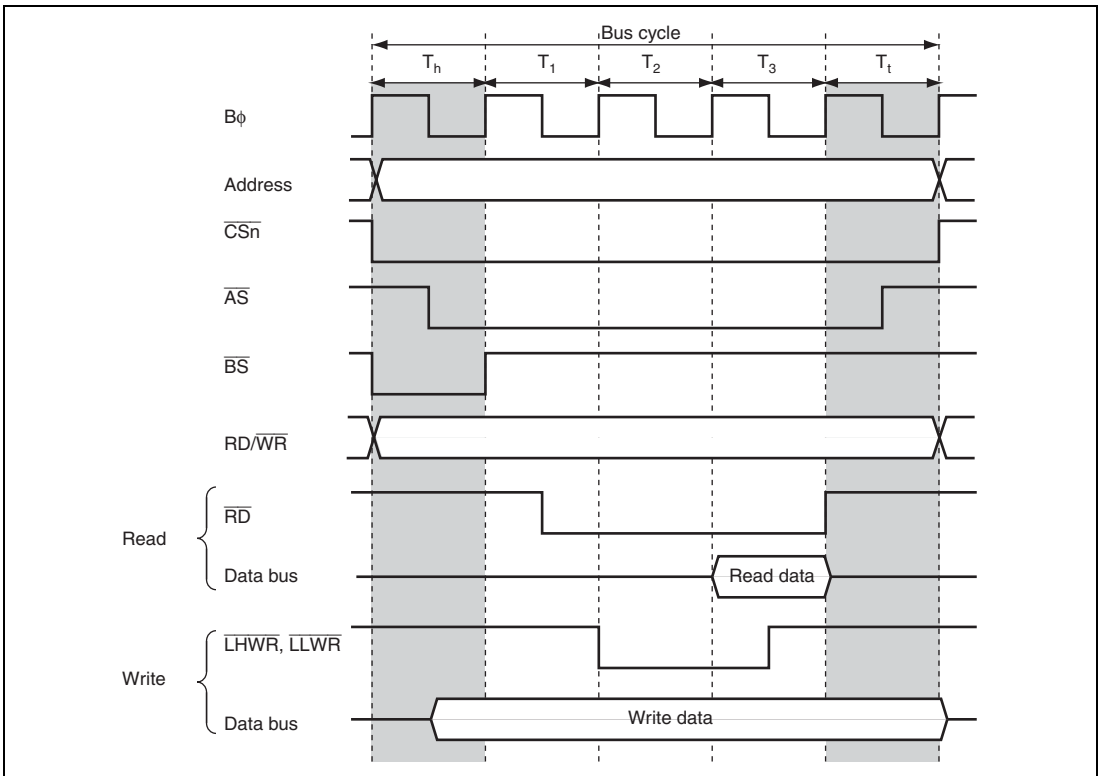

Figure 9.3 \overline{CS} and Address Assertion Period Extension
 (Example of Basic Bus Interface, 3-State Access Space, and $RDN_n = 0$)

9.2.6 Idle Control Register (IDLCR)

IDLCR specifies the idle cycle insertion conditions and the number of idle cycles.

Bit	15	14	13	12	11	10	9	8
Bit Name	IDLS3	IDLS2	IDLS1	IDLS0	IDLCB1	IDLCB0	IDLCA1	IDLCA0
Initial Value	1	1	1	1	1	1	1	1
R/W	R/W	R/W	R/W	R/W	R/W	R/W	R/W	R/W
Bit	7	6	5	4	3	2	1	0
Bit Name	IDLSEL7	IDLSEL6	IDLSEL5	IDLSEL4	IDLSEL3	IDLSEL2	IDLSEL1	IDLSEL0
Initial Value	0	0	0	0	0	0	0	0
R/W	R/W	R/W	R/W	R/W	R/W	R/W	R/W	R/W

Bit	Bit Name	Initial Value	R/W	Description
15	IDLS3	1	R/W	Idle Cycle Insertion 3 Inserts an idle cycle between the bus cycles when the DMAC single address transfer (write cycle) is followed by external access. 0: No idle cycle is inserted 1: An idle cycle is inserted
14	IDLS2	1	R/W	Idle Cycle Insertion 2 Inserts an idle cycle between the bus cycles when the external write cycle is followed by external read cycle. 0: No idle cycle is inserted 1: An idle cycle is inserted
13	IDLS1	1	R/W	Idle Cycle Insertion 1 Inserts an idle cycle between the bus cycles when the external read cycles of different areas continue. 0: No idle cycle is inserted 1: An idle cycle is inserted

Bit	Bit Name	Initial Value	R/W	Description
12	IDLS0	1	R/W	Idle Cycle Insertion 0 Inserts an idle cycle between the bus cycles when the external read cycle is followed by external write cycle. 0: No idle cycle is inserted 1: An idle cycle is inserted
11	IDLCB1	1	R/W	Idle Cycle State Number Select B
10	IDLCB0	1	R/W	Specifies the number of idle cycles to be inserted for the idle condition specified by IDLS1 and IDLS0. 00: No idle cycle is inserted 01: 2 idle cycles are inserted 00: 3 idle cycles are inserted 01: 4 idle cycles are inserted
9	IDLCA1	1	R/W	Idle Cycle State Number Select A
8	IDLCA0	1	R/W	Specifies the number of idle cycles to be inserted for the idle condition specified by IDLS3 to IDLS0. 00: 1 idle cycle is inserted 01: 2 idle cycles are inserted 10: 3 idle cycles are inserted 11: 4 idle cycles are inserted
7	IDLSEL7	0	R/W	Idle Cycle Number Select
6	IDLSEL6	0	R/W	Specifies the number of idle cycles to be inserted for each area for the idle insertion condition specified by IDLS1 and IDLS0.
5	IDLSEL5	0	R/W	
4	IDLSEL4	0	R/W	
3	IDLSEL3	0	R/W	0: Number of idle cycles to be inserted for area n is specified by IDLCA1 and IDLCA0.
2	IDLSEL2	0	R/W	1: Number of idle cycles to be inserted for area n is specified by IDLCB1 and IDLCB0.
1	IDLSEL1	0	R/W	
0	IDLSELO	0	R/W	(n = 7 to 0)

9.2.7 Bus Control Register 1 (BCR1)

BCR1 is used for selection of the external bus released state protocol, enabling/disabling of the write data buffer function, and enabling/disabling of the $\overline{\text{WAIT}}$ pin input.

Bit	15	14	13	12	11	10	9	8
Bit Name	BRLE	BREQOE	—	—	—	—	WDBE	WAITE
Initial Value	0	0	0	0	0	0	0	0
R/W	R/W	R/W	R	R	R/W	R/W	R/W	R/W
Bit	7	6	5	4	3	2	1	0
Bit Name	DKC	—	—	—	—	—	—	—
Initial Value	0	0	0	0	0	0	0	0
R/W	R/W	R/W	R	R	R	R	R	R

Bit	Bit Name	Initial Value	R/W	Description
15	BRLE	0	R/W	<p>External Bus Release Enable</p> <p>Enables/disables external bus release.</p> <p>0: External bus release disabled</p> <p>$\overline{\text{BREQ}}$, $\overline{\text{BACK}}$, and $\overline{\text{BREQO}}$ pins can be used as I/O ports</p> <p>1: External bus release enabled*</p> <p>For details, see section 12, I/O Ports.</p>
14	BREQOE	0	R/W	<p>$\overline{\text{BREQO}}$ Pin Enable</p> <p>Controls outputting the bus request signal ($\overline{\text{BREQO}}$) to the external bus master in the external bus released state when an internal bus master performs an external address space access.</p> <p>0: $\overline{\text{BREQO}}$ output disabled</p> <p>$\overline{\text{BREQO}}$ pin can be used as I/O port</p> <p>1: $\overline{\text{BREQO}}$ output enabled</p>

Bit	Bit Name	Initial Value	R/W	Description
13, 12	—	All 0	R	Reserved These are read-only bits and cannot be modified.
11, 10	—	All 0	R/W	Reserved These bits are always read as 0. The write value should always be 0.
9	WDBE	0	R/W	Write Data Buffer Enable The write data buffer function can be used for an external write cycle and a DMAC single address transfer cycle. The changed setting may not affect an external access immediately after the change. 0: Write data buffer function not used 1: Write data buffer function used
8	WAITE	0	R/W	$\overline{\text{WAIT}}$ Pin Enable Selects enabling/disabling of wait input by the $\overline{\text{WAIT}}$ pin. 0: Wait input by $\overline{\text{WAIT}}$ pin disabled $\overline{\text{WAIT}}$ pin can be used as I/O port 1: Wait input by $\overline{\text{WAIT}}$ pin enabled For details, see section 12, I/O Ports.
7	DKC	0	R/W	$\overline{\text{DACK}}$ Control Selects the timing of DMAC transfer acknowledge signal assertion. 0: $\overline{\text{DACK}}$ signal is asserted at the $B\phi$ falling edge 1: $\overline{\text{DACK}}$ signal is asserted at the $B\phi$ rising edge
6	—	0	R/W	Reserved This bit is always read as 0. The write value should always be 0.
5 to 0	—	All 0	R	Reserved These are read-only bits and cannot be modified.

Note: When external bus release is enabled or input by the $\overline{\text{WAIT}}$ pin is enabled, make sure to set the ICR bit to 1. For details, see section 12, I/O Ports.

9.2.8 Bus Control Register 2 (BCR2)

BCR2 is used for bus arbitration control of the CPU, DMAC, and DTC, and enabling/disabling of the write data buffer function to the peripheral modules.

Bit	7	6	5	4	3	2	1	0
Bit Name	—	—	—	IBCCS	—	—	—	PWDBE
Initial Value	0	0	0	0	0	0	1	0
R/W	R	R	R/W	R/W	R	R	R/W	R/W

Bit	Bit Name	Initial Value	R/W	Description
7, 6	—	All 0	R	Reserved These are read-only bits and cannot be modified.
5	—	0	R/W	Reserved This bit is always read as 0. The write value should always be 0.
4	IBCCS	0	R/W	Internal Bus Cycle Control Select Selects the internal bus arbiter function. 0: Releases the bus mastership according to the priority 1: Executes the bus cycles alternatively when a CPU bus mastership request conflicts with a DMAC or DTC bus mastership request
3, 2	—	All 0	R	Reserved These are read-only bits and cannot be modified.
1	—	1	R/W	Reserved This bit is always read as 1. The write value should always be 1.
0	PWDBE	0	R/W	Peripheral Module Write Data Buffer Enable Specifies whether or not to use the write data buffer function for the peripheral module write cycles. 0: Write data buffer function not used 1: Write data buffer function used

9.2.9 Endian Control Register (ENDIANCR)

ENDIANCR selects the endian format for each area of the external address space. Though the data format of this LSI is big endian, data can be transferred in the little endian format during external address space access.

Note that the data format for the areas used as a program area or a stack area should be big endian.

Bit	7	6	5	4	3	2	1	0
Bit Name	LE7	LE6	LE5	LE4	LE3	LE2	—	—
Initial Value	0	0	0	0	0	0	0	0
R/W	R/W	R/W	R/W	R/W	R/W	R/W	R	R

Bit	Bit Name	Initial Value	R/W	Description
7	LE7	0	R/W	Little Endian Select
6	LE6	0	R/W	Selects the endian for the corresponding area.
5	LE5	0	R/W	0: Data format of area n is specified as big endian
4	LE4	0	R/W	1: Data format of area n is specified as little endian
3	LE3	0	R/W	(n = 7 to 2)
2	LE2	0	R/W	
1, 0	—	All 0	R	Reserved

These are read-only bits and cannot be modified.

9.2.10 SRAM Mode Control Register (SRAMCR)

SRAMCR specifies the bus interface of each area in the external address space as a basic bus interface or a byte control SRAM interface.

In areas specified as 8-bit access space by ABWCR, the SRAMCR setting is ignored and the byte control SRAM interface cannot be specified.

Bit	15	14	13	12	11	10	9	8
Bit Name	BCSEL7	BCSEL6	BCSEL5	BCSEL4	BCSEL3	BCSEL2	BCSEL1	BCSEL0
Initial Value	0	0	0	0	0	0	0	0
R/W	R/W	R/W	R/W	R/W	R/W	R/W	R/W	R/W
Bit	7	6	5	4	3	2	1	0
Bit Name	—	—	—	—	—	—	—	—
Initial Value	0	0	0	0	0	0	0	0
R/W	R	R	R	R	R	R	R	R

Bit	Bit Name	Initial Value	R/W	Description
15	BCSEL7	0	R/W	Byte Control SRAM Interface Select
14	BCSEL6	0	R/W	Selects the bus interface for the corresponding area.
13	BCSEL5	0	R/W	When setting a bit to 1, the bus interface select bits in BROMCR and MPXCR must be cleared to 0.
12	BCSEL4	0	R/W	
11	BCSEL3	0	R/W	0: Area n is basic bus interface
10	BCSEL2	0	R/W	1: Area n is byte control SRAM interface
9	BCSEL1	0	R/W	(n = 7 to 0)
8	BCSEL0	0	R/W	
7 to 0	—	All 0	R	Reserved
These are read-only bits and cannot be modified.				

9.2.11 Burst ROM Interface Control Register (BROMCR)

BROMCR specifies the burst ROM interface.

Bit	15	14	13	12	11	10	9	8
Bit Name	BSRM0	BSTS02	BSTS01	BSTS00	—	—	BSWD01	BSWD00
Initial Value	0	0	0	0	0	0	0	0
R/W	R/W	R/W	R/W	R/W	R	R	R/W	R/W
Bit	7	6	5	4	3	2	1	0
Bit Name	BSRM1	BSTS12	BSTS11	BSTS10	—	—	BSWD11	BSWD10
Initial Value	0	0	0	0	0	0	0	0
R/W	R/W	R/W	R/W	R/W	R	R	R/W	R/W

Bit	Bit Name	Initial Value	R/W	Description
15	BSRM0	0	R/W	Area 0 Burst ROM Interface Select Specifies the area 0 bus interface. To set this bit to 1, clear bit BCSEL0 in SRAMCR to 0. 0: Basic bus interface or byte-control SRAM interface 1: Burst ROM interface
14	BSTS02	0	R/W	Area 0 Burst Cycle Select
13	BSTS01	0	R/W	Specifies the number of burst cycles of area 0
12	BSTS00	0	R/W	000: 1 cycle 001: 2 cycles 010: 3 cycles 011: 4 cycles 100: 5 cycles 101: 6 cycles 110: 7 cycles 111: 8 cycles
11, 10	—	All 0	R	Reserved These are read-only bits and cannot be modified.

Bit	Bit Name	Initial Value	R/W	Description
9	BSWD01	0	R/W	Area 0 Burst Word Number Select
8	BSWD00	0	R/W	Selects the number of words in burst access to the area 0 burst ROM interface 00: Up to 4 words (8 bytes) 01: Up to 8 words (16 bytes) 10: Up to 16 words (32 bytes) 11: Up to 32 words (64 bytes)
7	BSRM1	0	R/W	Area 1 Burst ROM Interface Select Specifies the area 1 bus interface as a basic interface or a burst ROM interface. To set this bit to 1, clear bit BCSEL1 in SRAMCR to 0. 0: Basic bus interface or byte-control SRAM interface 1: Burst ROM interface
6	BSTS12	0	R/W	Area 1 Burst Cycle Select
5	BSTS11	0	R/W	Specifies the number of cycles of area 1 burst cycle
4	BSTS10	0	R/W	000: 1 cycle 001: 2 cycles 010: 3 cycles 011: 4 cycles 100: 5 cycles 101: 6 cycles 110: 7 cycles 111: 8 cycles
3, 2	—	All 0	R	Reserved These are read-only bits and cannot be modified.
1	BSWD11	0	R/W	Area 1 Burst Word Number Select
0	BSWD10	0	R/W	Selects the number of words in burst access to the area 1 burst ROM interface 00: Up to 4 words (8 bytes) 01: Up to 8 words (16 bytes) 10: Up to 16 words (32 bytes) 11: Up to 32 words (64 bytes)

9.2.12 Address/Data Multiplexed I/O Control Register (MPXCR)

MPXCR specifies the address/data multiplexed I/O interface.

Bit	15	14	13	12	11	10	9	8
Bit Name	MPXE7	MPXE6	MPXE5	MPXE4	MPXE3	—	—	—
Initial Value	0	0	0	0	0	0	0	0
R/W	R/W	R/W	R/W	R/W	R/W	R	R	R
Bit	7	6	5	4	3	2	1	0
Bit Name	—	—	—	—	—	—	—	ADDEX
Initial Value	0	0	0	0	0	0	0	0
R/W	R	R	R	R	R	R	R	R/W

Bit	Bit Name	Initial Value	R/W	Description
15	MPXE7	0	R/W	Address/Data Multiplexed I/O Interface Select
14	MPXE6	0	R/W	Specifies the bus interface for the corresponding area.
13	MPXE5	0	R/W	To set this bit to 1, clear the BCSELn bit in SRAMCR to 0.
12	MPXE4	0	R/W	0: Area n is specified as a basic interface or a byte control SRAM interface.
11	MPXE3	0	R/W	1: Area n is specified as an address/data multiplexed I/O interface (n = 7 to 3)
10 to 1	—	All 0	R	Reserved These are read-only bits and cannot be modified.
0	ADDEX	0	R/W	Address Output Cycle Extension Specifies whether a wait cycle is inserted for the address output cycle of address/data multiplexed I/O interface. 0: No wait cycle is inserted for the address output cycle 1: One wait cycle is inserted for the address output cycle

9.3 Bus Configuration

Figure 9.4 shows the internal bus configuration of this LSI. The internal bus of this LSI consists of the following three types.

- **Internal system bus**
A bus that connects the CPU, DTC, DMAC, on-chip RAM, on-chip ROM, internal peripheral bus, and external access bus.
- **Internal peripheral bus**
A bus that accesses registers in the bus controller, interrupt controller, and DMAC, and registers of peripheral modules such as SCI and timer.
- **External access cycle**
A bus that accesses external devices via the external bus interface.

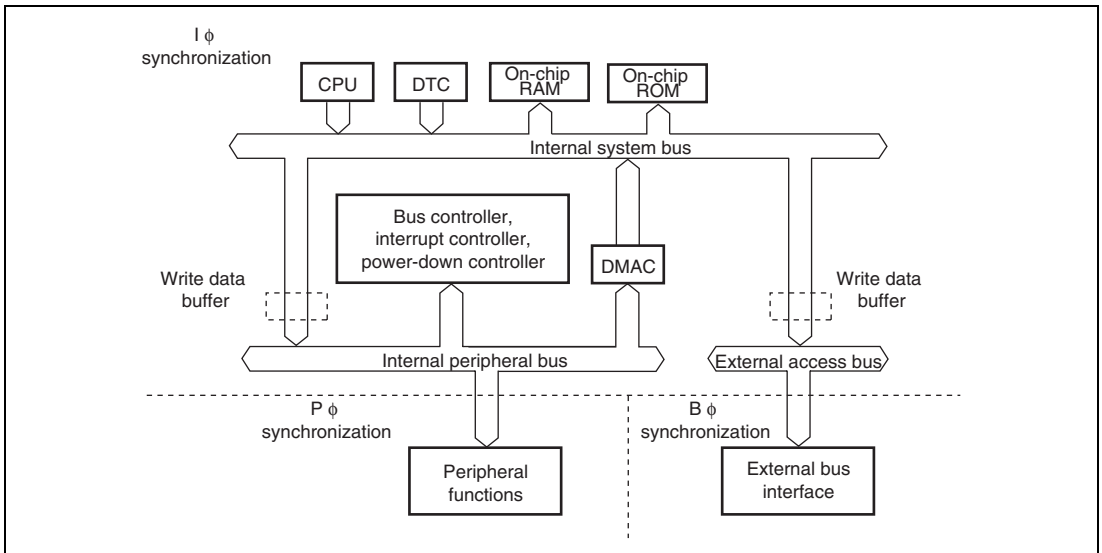

Figure 9.4 Internal Bus Configuration

9.4 Multi-Clock Function and Number of Access Cycles

The internal functions of this LSI operate synchronously with the system clock ($I\phi$), the peripheral module clock ($P\phi$), or the external bus clock ($B\phi$). Table 9.1 shows the synchronization clock and their corresponding functions.

Table 9.1 Synchronization Clocks and Their Corresponding Functions

Synchronization Clock	Function Name
$I\phi$	MCU operating mode Interrupt controller Bus controller CPU DTC DMAC Internal memory Clock pulse generator Power down control
$P\phi$	I/O ports TPU PPG TMR WDT SCI A/D D/A IIC2
$B\phi$	External bus interface

The frequency of each synchronization clock ($I\phi$, $P\phi$, and $B\phi$) is specified by the system clock control register (SCKCR) independently. For further details, see section 24, Clock Pulse Generator.

There will be cases when $P\phi$ and $B\phi$ are equal to $I\phi$ and when $P\phi$ and $B\phi$ are different from $I\phi$ according to the SCKCR specifications. In any case, access cycles for internal peripheral functions and external space is performed synchronously with $P\phi$ and $B\phi$, respectively.

For example, in an external address space access where the frequency rate of $I\phi$ and $B\phi$ is $n : 1$, the operation is performed in synchronization with $B\phi$. In this case, external 2-state access space is $2n$ cycles and external 3-state access space is $3n$ cycles (no wait cycles is inserted) if the number of access cycles is counted based on $I\phi$.

If the frequencies of $I\phi$, $P\phi$ and $B\phi$ are different, the start of bus cycle may not synchronize with $P\phi$ or $B\phi$ according to the bus cycle initiation timing. In this case, clock synchronization cycle (T_{sy}) is inserted at the beginning of each bus cycle.

For example, if an external address space access occurs when the frequency rate of $I\phi$ and $B\phi$ is $n : 1$, 0 to $n-1$ cycles of T_{sy} may be inserted. If an internal peripheral module access occurs when the frequency rate of $I\phi$ and $P\phi$ is $m : 1$, 0 to $m-1$ cycles of T_{sy} may be inserted.

Figure 9.5 shows the external 2-state access timing when the frequency rate of $I\phi$ and $B\phi$ is $4 : 1$.
Figure 9.6 shows the external 3-state access timing when the frequency rate of $I\phi$ and $B\phi$ is $2 : 1$.

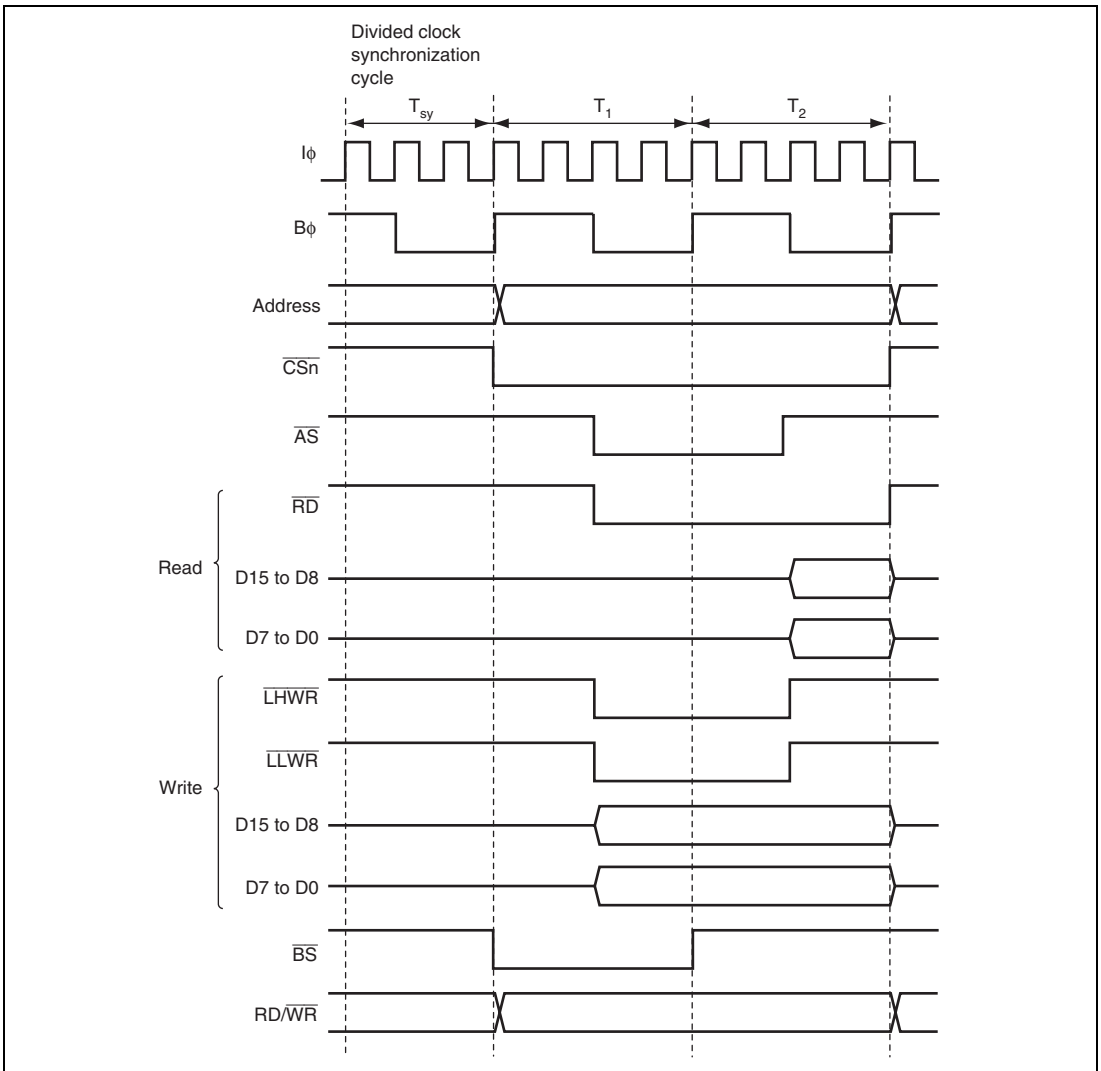

Figure 9.5 System Clock: External Bus Clock = 4:1, External 2-State Access

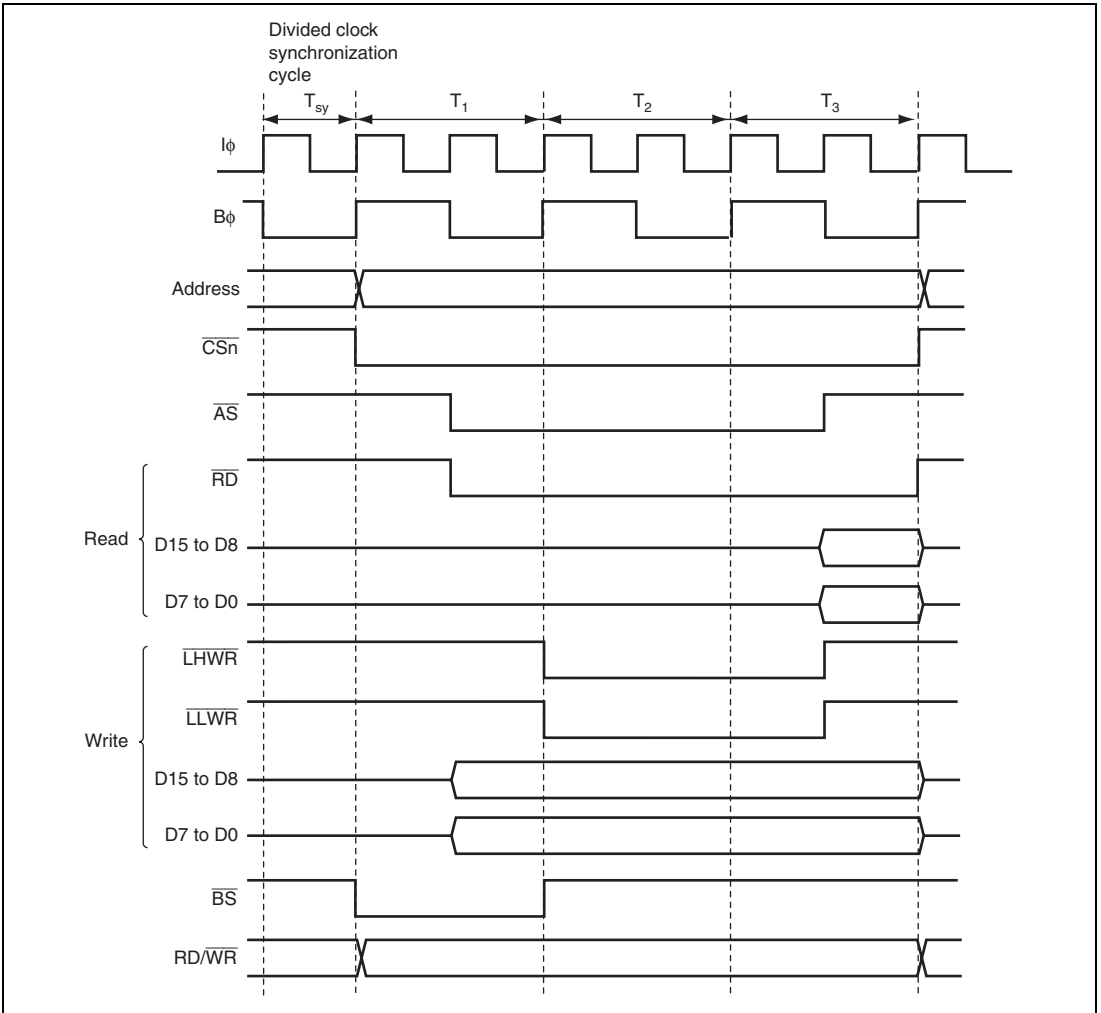

Figure 9.6 System Clock: External Bus Clock = 2:1, External 3-State Access

9.5 External Bus

9.5.1 Input/Output Pins

Table 9.2 shows the pin configuration of the bus controller and table 9.3 shows the pin functions on each interface.

Table 9.2 Pin Configuration

Name	Symbol	I/O	Function
Bus cycle start	\overline{BS}	Output	Signal indicating that the bus cycle has started
Address strobe/ address hold	$\overline{AS/AH}$	Output	<ul style="list-style-type: none"> Strobe signal indicating that the basic bus, byte control SRAM, or burst ROM space is accessed and address output on address bus is enabled Signal to hold the address during access to the address/data multiplexed I/O interface
Read strobe	\overline{RD}	Output	Strobe signal indicating that the basic bus, byte control SRAM, burst ROM, or address/data multiplexed I/O space is being read
Read/write	RD/\overline{WR}	Output	<ul style="list-style-type: none"> Signal indicating the input or output direction Write enable signal of the SRAM during access to the byte control SRAM space
Low-high write/ lower-upper byte select	$\overline{LHWR/LUB}$	Output	<ul style="list-style-type: none"> Strobe signal indicating that the basic bus, burst ROM, or address/data multiplexed I/O space is written to, and the upper byte (D15 to D8) of data bus is enabled Strobe signal indicating that the byte control SRAM space is accessed, and the upper byte (D15 to D8) of data bus is enabled
Low-low write/ lower-lower byte select	$\overline{LLWR/LLB}$	Output	<ul style="list-style-type: none"> Strobe signal indicating that the basic bus, burst ROM, or address/data multiplexed I/O space is written to, and the lower byte (D7 to D0) of data bus is enabled Strobe signal indicating that the byte control SRAM space is accessed, and the lower byte (D7 to D0) of data bus is enabled

Name	Symbol	I/O	Function
Chip select 0	$\overline{CS0}$	Output	Strobe signal indicating that area 0 is selected
Chip select 1	$\overline{CS1}$	Output	Strobe signal indicating that area 1 is selected
Chip select 2	$\overline{CS2}$	Output	Strobe signal indicating that area 2 is selected
Chip select 3	$\overline{CS3}$	Output	Strobe signal indicating that area 3 is selected
Chip select 4	$\overline{CS4}$	Output	Strobe signal indicating that area 4 is selected
Chip select 5	$\overline{CS5}$	Output	Strobe signal indicating that area 5 is selected
Chip select 6	$\overline{CS6}$	Output	Strobe signal indicating that area 6 is selected
Chip select 7	$\overline{CS7}$	Output	Strobe signal indicating that area 7 is selected
Wait	\overline{WAIT}	Input	Wait request signal when accessing external address space.
Bus request	\overline{BREQ}	Input	Request signal for release of bus to external bus master
Bus request acknowledge	\overline{BACK}	Output	Acknowledge signal indicating that bus has been released to external bus master
Bus request output	\overline{BREQO}	Output	External bus request signal used when internal bus master accesses external address space in the external-bus released state
Data transfer acknowledge 3 (DMAC_3)	$\overline{DACK3}$	Output	Data transfer acknowledge signal for DMAC_3 single address transfer
Data transfer acknowledge 2 (DMAC_2)	$\overline{DACK2}$	Output	Data transfer acknowledge signal for DMAC_2 single address transfer
Data transfer acknowledge 1 (DMAC_1)	$\overline{DACK1}$	Output	Data transfer acknowledge signal for DMAC_1 single address transfer
Data transfer acknowledge 0 (DMAC_0)	$\overline{DACK0}$	Output	Data transfer acknowledge signal for DMAC_0 single address transfer
External bus clock	B ϕ	Output	External bus clock

Table 9.3 Pin Functions in Each Interface

Pin Name	Initial State			Basic Bus		Byte Control SRAM		Burst ROM		Address/Data Multiplexed I/O		Remarks
	16	8	Single-Chip	16	8	16	16	8	16	8		
	$B\phi$	Output	Output	—	O	O	O	O	O	O	O	
$\overline{CS0}$	Output	Output	—	O	O	O	O	O	—	—		
$\overline{CS1}$	—	—	—	O	O	O	O	O	—	—		
$\overline{CS2}$	—	—	—	O	O	O	—	—	—	—		
$\overline{CS3}$	—	—	—	O	O	O	—	—	O	O		
$\overline{CS4}$	—	—	—	O	O	O	—	—	O	O		
$\overline{CS5}$	—	—	—	O	O	O	—	—	O	O		
$\overline{CS6}$	—	—	—	O	O	O	—	—	O	O		
$\overline{CS7}$	—	—	—	O	O	O	—	—	O	O		
BS	—	—	—	O	O	O	O	O	O	O		
RD/WR	—	—	—	O	O	O	O	O	O	O		
\overline{AS}	Output	Output	—	O	O	O	O	O	—	—		
AH	—	—	—	—	—	—	—	—	O	O		
\overline{RD}	Output	Output	—	O	O	O	O	O	O	O		
$\overline{LHWR/LUB}$	Output	Output	—	O	—	O	O	—	O	—		
$\overline{LLWR/LLB}$	Output	Output	—	O	O	O	O	O	O	O		
\overline{WAIT}	—	—	—	O	O	O	O	O	O	O	Controlled by WAITE	

[Legend]

O: Used as a bus control signal

—: Not used as a bus control signal (used as a port input when initialized)

9.5.2 Area Division

The bus controller divides the 16-Mbyte address space into eight areas, and performs bus control for the external address space in area units. Chip select signals ($\overline{CS0}$ to $\overline{CS7}$) can be output for each area.

Figure 9.7 shows an area division of the 16-Mbyte address space. For details on address map, see section 3, MCU Operating Modes.

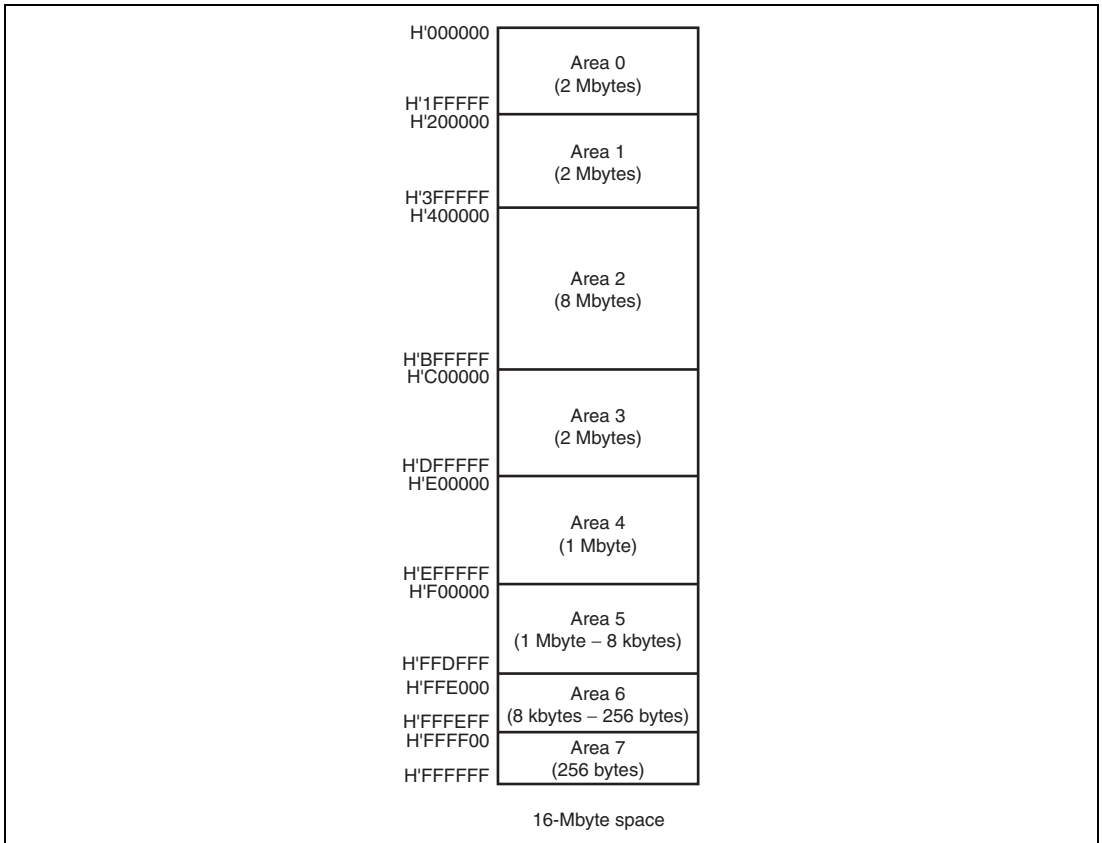

Figure 9.7 Address Space Area Division

9.5.3 Chip Select Signals

This LSI can output chip select signals ($\overline{CS0}$ to $\overline{CS7}$) for areas 0 to 7. The signal outputs low when the corresponding external address space area is accessed. Figure 9.8 shows an example of \overline{CSn} ($n = 0$ to 7) signal output timing.

Enabling or disabling of \overline{CSn} signal output is set by the port function control register (PFCR). For details, see section 12.3, Port Function Controller.

In on-chip ROM disabled extended mode, pin $\overline{CS0}$ is placed in the output state after a reset. Pins $\overline{CS1}$ to $\overline{CS7}$ are placed in the input state after a reset and so the corresponding PFCR bits should be set to 1 when outputting signals $\overline{CS1}$ to $\overline{CS7}$.

In on-chip ROM enabled extended mode, pins $\overline{CS0}$ to $\overline{CS7}$ are all placed in the input state after a reset and so the corresponding PFCR bits should be set to 1 when outputting signals $\overline{CS0}$ to $\overline{CS7}$.

The PFCR can specify multiple \overline{CS} outputs for a pin. If multiple \overline{CSn} outputs are specified for a single pin by the PFCR, \overline{CS} to be output are generated by mixing all the \overline{CS} signals. In this case, the settings for the external bus interface areas in which the \overline{CSn} signals are output to a single pin should be the same.

Figure 9.9 shows the signal output timing when the \overline{CS} signals to be output to areas 5 and 6 are output to the same pin.

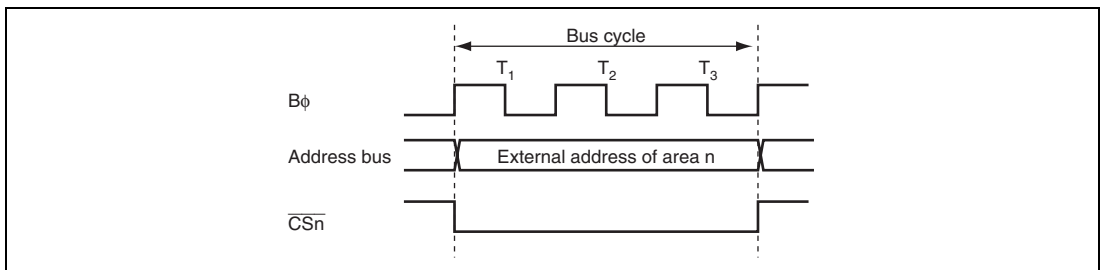

Figure 9.8 \overline{CSn} Signal Output Timing ($n = 0$ to 7)

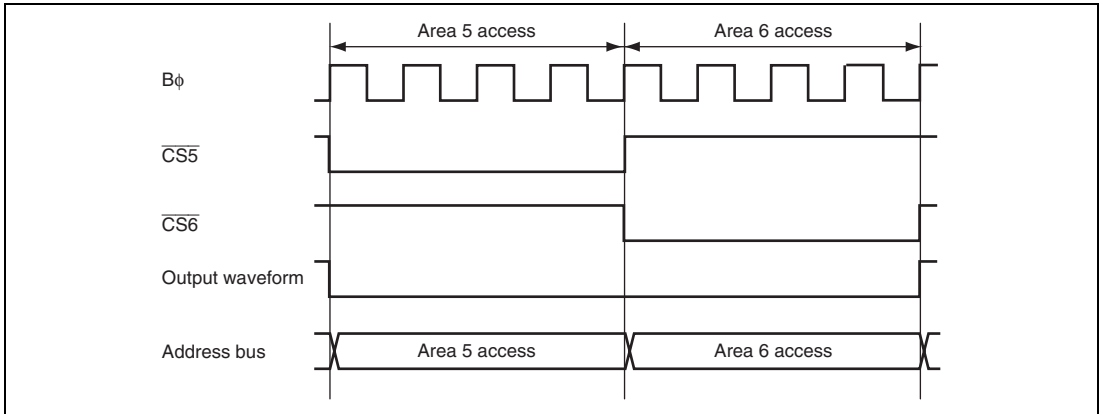

Figure 9.9 Timing When \overline{CS} Signal is Output to the Same Pin

9.5.4 External Bus Interface

The type of the external bus interfaces, bus width, endian format, number of access cycles, and strobe assert/negate timings can be set for each area in the external address space. The bus width and the number of access cycles for both on-chip memory and internal I/O registers are fixed, and are not affected by the external bus settings.

(1) Type of External Bus Interface

Four types of external bus interfaces are provided and can be selected in area units. Table 9.4 shows each interface name, description, area name to be set for each interface. Table 9.5 shows the areas that can be specified for each interface. The initial state of each area is a basic bus interface.

Table 9.4 Interface Names and Area Names

Interface	Description	Area Name
Basic interface	Directly connected to ROM and RAM	Basic bus space
Byte control SRAM interface	Directly connected to byte SRAM with byte control pin	Byte control SRAM space
Burst ROM interface	Directly connected to the ROM that allows page access	Burst ROM space
Address/data multiplexed I/O interface	Directly connected to the peripheral LSI that requires address and data multiplexing	Address/data multiplexed I/O space

Table 9.5 Areas Specifiable for Each Interface

Interface	Related Registers	Areas							
		0	1	2	3	4	5	6	7
Basic interface	SRAMCR	0	0	0	0	0	0	0	0
Byte control SRAM interface		0	0	0	0	0	0	0	0
Burst ROM interface	BROMCR	0	0	—	—	—	—	—	—
Address/data multiplexed I/O interface	MPXCR	—	—	—	0	0	0	0	0

(2) Bus Width

A bus width of 8 or 16 bits can be selected with ABWCR. An area for which an 8-bit bus is selected functions as an 8-bit access space and an area for which a 16-bit bus is selected functions as a 16-bit access space. In addition, the bus width of address/data multiplexed I/O space is 8 bits or 16 bits, and the bus width for the byte control SRAM space is 16 bits.

The initial state of the bus width is specified by the operating mode.

If all areas are designated as 8-bit access space, 8-bit bus mode is set; if any area is designated as 16-bit access space, 16-bit bus mode is set.

(3) Endian Format

Though the endian format of this LSI is big endian, data can be converted into little endian format when reading or writing to the external address space.

Areas 7 to 2 can be specified as either big endian or little endian format by the LE7 to LE2 bits in ENDIANCR.

The initial state of each area is the big endian format.

Note that the data format for the areas used as a program area or a stack area should be big endian.

(4) Number of Access Cycles

(a) Basic Bus Interface

The number of access cycles in the basic bus interface can be specified as two or three cycles by the ASTCR. An area specified as 2-state access is specified as 2-state access space; an area specified as 3-state access is specified as 3-state access space.

For the 2-state access space, a wait cycle insertion is disabled. For the 3-state access space, a program wait (0 to 7 cycles) specified by WTCRA and WTCRB or an external wait by $\overline{\text{WAIT}}$ can be inserted.

$$\begin{aligned} & \text{Number of access cycles in the basic bus interface} \\ & = \text{number of basic cycles (2, 3) + number of program wait cycles (0 to 7)} \\ & \quad + \text{number of } \overline{\text{CS}} \text{ extension cycles (0, 1, 2)} \\ & \quad [+ \text{number of external wait cycles by the } \overline{\text{WAIT}} \text{ pin}] \end{aligned}$$

Assertion period of the chip select signal can be extended by CSACR.

(b) Byte Control SRAM Interface

The number of access cycles in the byte control SRAM interface is the same as that in the basic bus interface.

$$\begin{aligned} & \text{Number of access cycles in byte control SRAM interface} \\ & = \text{number of basic cycles (2, 3) + number of program wait cycles (0 to 7)} \\ & \quad + \text{number of } \overline{\text{CS}} \text{ extension cycles (0, 1, 2)} \\ & \quad [+ \text{number of external wait cycles by the } \overline{\text{WAIT}} \text{ pin}] \end{aligned}$$

(c) Burst ROM Interface

The number of access cycles at full access in the burst ROM interface is the same as that in the basic bus interface. The number of access cycles in the burst access can be specified as one to eight cycles by the BSTS bit in BROMCR.

$$\begin{aligned} & \text{Number of access cycles in the burst ROM interface} \\ & = \text{number of basic cycles (2, 3) + number of program wait cycles (0 to 7)} \\ & \quad + \text{number of } \overline{\text{CS}} \text{ extension cycles (0, 1)} \\ & \quad [+ \text{number of external wait cycles by the } \overline{\text{WAIT}} \text{ pin}] \\ & \quad + \text{number of burst access cycles (1 to 8)} \times \text{number of burst accesses (0 to 63)} \end{aligned}$$

(d) Address/data multiplexed I/O interface

The number of access cycles in data cycle of the address/data multiplexed I/O interface is the same as that in the basic bus interface. The number of access cycles in address cycle can be specified as two or three cycles by the ADDEX bit in MPXCR.

$$\begin{aligned} & \text{Number of access cycles in the address/data multiplexed I/O interface} \\ & = \text{number of address output cycles (2, 3) + number of data output cycles (2, 3)} \\ & \quad + \text{number of program wait cycles (0 to 7)} \\ & \quad + \text{number of } \overline{\text{CS}} \text{ extension cycles (0, 1, 2)} \\ & \quad [+ \text{number of external wait cycles by the } \overline{\text{WAIT}} \text{ pin}] \end{aligned}$$

Table 9.6 lists the number of access cycles for each interface.

Table 9.6 Number of Access Cycles

Basic bus interface	=	Th	+T1	+T2				+Tt	
	-	[0,1]	[1]	[1]				[0,1]	[2 to 4]
Byte control SRAM interface	=	Th	+T1	+T2	+Tpw	+Ttw	+T3	+Tt	
	-	[0,1]	[1]	[1]	[0 to 7]	[n]	[1]	[0,1]	[3 to 12 + n]
Burst ROM interface	=	Th	+T1	+T2				+Tb	
	-	[0,1]	[1]	[1]				[(1 to 8) × m]	[(2 to 3) + (1 to 8) × m]
Address/data multiplexed I/O interface	=	Tma	+Th	+T1	+T2			+Tt	
	-	[2,3]	[0,1]	[1]	[1]			[0,1]	[4 to 7]
		Tma	+Th	+T1	+T2	+Tpw	+Ttw	+T3	+Tt
		[2,3]	[0,1]	[1]	[1]	[0 to 7]	[n]	[1]	[0,1]
									[5 to 15 + n]

[Legend]

Numbers: Number of access cycles

n: Pin wait (0 to ∞)

m: Number of burst accesses (0 to 63)

(5) Strobe Assert/Negate Timings

The assert and negate timings of the strobe signals can be modified as well as number of access cycles.

- Read strobe ($\overline{\text{RD}}$) in the basic bus interface
- Chip select assertion period extension cycles in the basic bus interface
- Data transfer acknowledge ($\overline{\text{DACK3}}$ to $\overline{\text{DACK0}}$) output for DMAC single address transfers

9.5.5 Area and External Bus Interface

(1) Area 0

Area 0 includes on-chip ROM. All of area 0 is used as external address space in on-chip ROM disabled extended mode, and the space excluding on-chip ROM is external address space in on-chip ROM enabled extended mode.

When area 0 external address space is accessed, the $\overline{CS0}$ signal can be output.

Either of the basic bus interface, byte control SRAM interface, or burst ROM interface can be selected for area 0 by bit BSRM0 in BROMCR and bit BCSEL0 in SRAMCR. Table 9.7 shows the external interface of area 0.

Table 9.7 Area 0 External Interface

Interface	Register Setting	
	BSRM0 of BROMCR	BCSEL0 of SRAMCR
Basic bus interface	0	0
Byte control SRAM interface	0	1
Burst ROM interface	1	0
Setting prohibited	1	1

(2) Area 1

n externally extended mode, all of area 1 is external address space. In on-chip ROM enabled extended mode, the space excluding on-chip ROM is external address space.

When area 1 external address space is accessed, the $\overline{CS1}$ signal can be output.

Either of the basic bus interface, byte control SRAM, or burst ROM interface can be selected for area 1 by bit BSRM1 in BROMCR and bit BCSEL1 in SRAMCR. Table 9.8 shows the external interface of area 1.

Table 9.8 Area 1 External Interface

Interface	Register Setting	
	BSRM1 of BROMCR	BCSEL1 of SRAMCR
Basic bus interface	0	0
Byte control SRAM interface	0	1
Burst ROM interface	1	0
Setting prohibited	1	1

(3) Area 2

In externally extended mode, all of area 2 is external address space.

When area 2 external address space is accessed, the $\overline{CS2}$ signal can be output.

Either the basic bus interface or byte control SRAM interface can be selected for area 2 by bit BCSEL2 in SRAMCR. Table 9.9 shows the external interface of area 2.

Table 9.9 Area 2 External Interface

Interface	Register Setting
	BCSEL2 of SRAMCR
Basic bus interface	0
Byte control SRAM interface	1

(4) Area 3

In externally extended mode, all of area 3 is external address space.

When area 3 external address space is accessed, the $\overline{CS3}$ signal can be output.

Either of the basic bus interface, byte control SRAM interface, or address/data multiplexed I/O interface can be selected for area 3 by bit MPXE3 in MPXCR and bit BCSEL3 in SRAMCR.

Table 9.10 shows the external interface of area 3.

Table 9.10 Area 3 External Interface

Interface	Register Setting	
	MPXE3 of MPXCR	BCSEL3 of SRAMCR
Basic bus interface	0	0
Byte control SRAM interface	0	1
Address/data multiplexed I/O interface	1	0
Setting prohibited	1	1

(5) Area 4

In externally extended mode, all of area 4 is external address space.

When area 4 external address space is accessed, the $\overline{CS4}$ signal can be output.

Either of the basic bus interface, byte control SRAM interface, or address/data multiplexed I/O interface can be selected for area 4 by bit MPXE4 in MPXCR and bit BCSEL4 in SRAMCR.

Table 9.11 shows the external interface of area 4.

Table 9.11 Area 4 External Interface

Interface	Register Setting	
	MPXE4 of MPXCR	BCSEL4 of SRAMCR
Basic bus interface	0	0
Byte control SRAM interface	0	1
Address/data multiplexed I/O interface	1	0
Setting prohibited	1	1

(6) Area 5

Area 5 includes the on-chip RAM and access prohibited spaces. In external extended mode, area 5, other than the on-chip RAM and access prohibited spaces, is external address space. Note that the on-chip RAM is enabled when the RAME bit in SYSCR are set to 1. If the RAME bit in SYSCR is cleared to 0, the on-chip RAM is disabled and the corresponding addresses are an external address space. For details, see section 3, MCU Operating Modes.

When area 5 external address space is accessed, the $\overline{CS5}$ signal can be output.

Either of the basic bus interface, byte control SRAM interface, or address/data multiplexed I/O interface can be selected for area 5 by the MPXE5 bit in MPXCR and the BCSEL5 bit in SRAMCR. Table 9.12 shows the external interface of area 5.

Table 9.12 Area 5 External Interface

Interface	Register Setting	
	MPXE5 of MPXCR	BCSEL5 of SRAMCR
Basic bus interface	0	0
Byte control SRAM interface	0	1
Address/data multiplexed I/O interface	1	0
Setting prohibited	1	1

(7) Area 6

Area 6 includes internal I/O registers. In external extended mode, area 6 other than on-chip I/O register area is external address space.

When area 6 external address space is accessed, the $\overline{CS6}$ signal can be output.

Either of the basic bus interface, byte control SRAM interface, or address/data multiplexed I/O interface can be selected for area 6 by the MPXE6 bit in MPXCR and the BCSEL6 bit in SRAMCR. Table 9.13 shows the external interface of area 6.

Table 9.13 Area 6 External Interface

Interface	Register Setting	
	MPXE6 of MPXCR	BCSEL6 of SRAMCR
Basic bus interface	0	0
Byte control SRAM interface	0	1
Address/data multiplexed I/O interface	1	0
Setting prohibited	1	1

(8) Area 7

Area 7 includes internal I/O registers. In external extended mode, area 7 other than internal I/O register area is external address space.

When area 7 external address space is accessed, the $\overline{CS7}$ signal can be output.

Either of the basic bus interface, byte control SRAM interface, or address/data multiplexed I/O interface can be selected for area 7 by the MPXE7 bit in MPXCR and the BCSEL7 bit in SRAMCR. Table 9.14 shows the external interface of area 7.

Table 9.14 Area 7 External Interface

Interface	Register Setting	
	MPXE7 of MPXCR	BCSEL7 of SRAMCR
Basic bus interface	0	0
Byte control SRAM interface	0	1
Address/data multiplexed I/O interface	1	0
Setting prohibited	1	1

9.5.6 Endian and Data Alignment

Data sizes for the CPU and other internal bus masters are byte, word, and longword. The bus controller has a data alignment function, and controls whether the upper byte data bus (D15 to D8) or lower data bus (D7 to D0) is used according to the bus specifications for the area being accessed (8-bit access space or 16-bit access space), the data size, and endian format when accessing external address space.

(1) 8-Bit Access Space

With the 8-bit access space, the lower byte data bus (D7 to D0) is always used for access. The amount of data that can be accessed at one time is one byte: a word access is performed as two byte accesses, and a longword access, as four byte accesses.

Figures 9.10 and 9.11 illustrate data alignment control for the 8-bit access space. Figure 9.10 shows the data alignment when the data endian format is specified as big endian. Figure 9.11 shows the data alignment when the data endian format is specified as little endian.

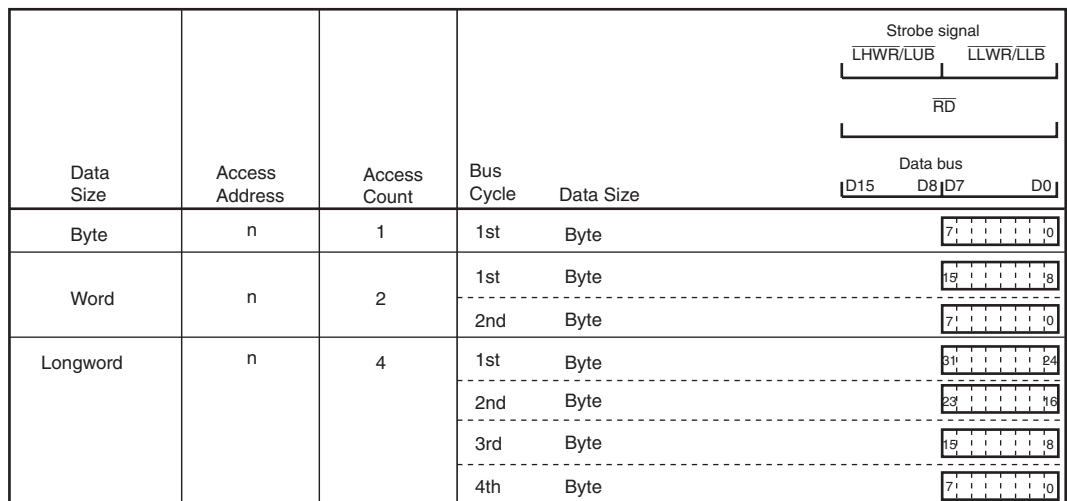

Figure 9.10 Access Sizes and Data Alignment Control for 8-Bit Access Space (Big Endian)

Data Size	Access Address	Access Count	Bus Cycle	Data Size	Strobe signal	
					LHWR/LUB	LLWR/LLB
					RD	
					Data bus	
					D15	D0
Byte	n	1	1st	Byte	7	0
Word	n	2	1st	Byte	7	0
			2nd	Byte	15	8
Longword	n	4	1st	Byte	7	0
			2nd	Byte	15	8
			3rd	Byte	23	16
			4th	Byte	31	24

Figure 9.11 Access Sizes and Data Alignment Control for 8-Bit Access Space (Little Endian)

(2) 16-Bit Access Space

With the 16-bit access space, the upper byte data bus (D15 to D8) and lower byte data bus (D7 to D0) are used for accesses. The amount of data that can be accessed at one time is one byte or one word.

Figures 9.12 and 9.13 illustrate data alignment control for the 16-bit access space. Figure 9.12 shows the data alignment when the data endian format is specified as big endian. Figure 9.13 shows the data alignment when the data endian format is specified as little endian.

In big endian, byte access for an even address is performed by using the upper byte data bus and byte access for an odd address is performed by using the lower byte data bus.

In little endian, byte access for an even address is performed by using the lower byte data bus, and byte access for an odd address is performed by using the third byte data bus.

Access Size	Access Address	Access Count	Bus Cycle	Data Size	Strobe signal				
					LHWR/LUB	LLWR/LLB			
					RD				
					Data bus				
					D15	D8 D7	D0		
Byte	Even (2n)	1	1st	Byte	7	1	0		
	Odd (2n+1)	1	1st	Byte	7	1	0		
Word	Even (2n)	1	1st	Word	15	8	7	1	0
	Odd (2n+1)	2	1st	Byte	15	8	15	8	
			2nd	Byte	7	1	0		
Longword	Even (2n)	2	1st	Word	31	24	23	16	15
			2nd	Word	15	8	7	1	0
	Odd (2n+1)	3	1st	Byte	31	24	31	24	
			2nd	Word	23	16	15	8	
			3rd	Byte	7	1	0		

Figure 9.12 Access Sizes and Data Alignment Control for 16-Bit Access Space (Big Endian)

Access Size	Access Address	Access Count	Bus Cycle	Data Size	Strobe signal				
					LHWR/LUB	LLWR/LLB			
					RD				
					Data bus				
					D15	D8 D7	D0		
Byte	Even (2n)	1	1st	Byte	7	1	0		
	Odd (2n+1)	1	1st	Byte	7	1	0		
Word	Even (2n)	1	1st	Word	15	8	7	1	0
	Odd (2n+1)	2	1st	Byte	7	1	0		
			2nd	Byte	15	8	15	8	
Longword	Even (2n)	2	1st	Word	15	8	7	1	0
			2nd	Word	31	24	23	16	
	Odd (2n+1)	3	1st	Byte	7	1	0		
			2nd	Word	23	16	15	8	
			3rd	Byte	31	24	31	24	

Figure 9.13 Access Sizes and Data Alignment Control for 16-Bit Access Space (Little Endian)

9.6 Basic Bus Interface

The basic bus interface can be connected directly to the ROM and SRAM. The bus specifications can be specified by the ABWCR, ASTCR, WTCRA, WTCRB, RDNCR, CSACR, and ENDIANCR.

9.6.1 Data Bus

Data sizes for the CPU and other internal bus masters are byte, word, and longword. The bus controller has a data alignment function, and controls whether the upper byte data bus (D15 to D8) or lower byte data bus (D7 to D0) is used according to the bus specifications for the area being accessed (8-bit access space or 16-bit access space), the data size, and endian format when accessing external address space. For details, see section 9.5.6, Endian and Data Alignment.

9.6.2 I/O Pins Used for Basic Bus Interface

Table 9.15 shows the pins used for basic bus interface.

Table 9.15 I/O Pins for Basic Bus Interface

Name	Symbol	I/O	Function
Bus cycle start	\overline{BS}	Output	Signal indicating that the bus cycle has started
Address strobe	\overline{AS}^*	Output	Strobe signal indicating that an address output on the address bus is valid during access
Read strobe	\overline{RD}	Output	Strobe signal indicating the read access
Read/write	$\overline{RD}/\overline{WR}$	Output	Signal indicating the data bus input or output direction
Low-high write	\overline{LHWR}	Output	Strobe signal indicating that the upper byte (D15 to D8) is valid during write access
Low-low write	\overline{LLWR}	Output	Strobe signal indicating that the lower byte (D7 to D0) is valid during write access
Chip select 0 to 7	$\overline{CS0}$ to $\overline{CS7}$	Output	Strobe signal indicating that the area is selected
Wait	\overline{WAIT}	Input	Wait request signal used when an external address space is accessed

Note: * When the address/data multiplexed I/O is selected, this pin only functions as the AH output and does not function as the AS output.

9.6.3 Basic Timing

This section describes the basic timing when the data is specified as big endian.

(1) 16-Bit 2-State Access Space

Figures 9.14 to 9.16 show the bus timing of 16-bit 2-state access space.

When accessing 16-bit access space, the upper byte data bus (D15 to D8) is used for even addresses access, and the lower byte data bus (D7 to D0) is used for odd addresses. No wait cycles can be inserted.

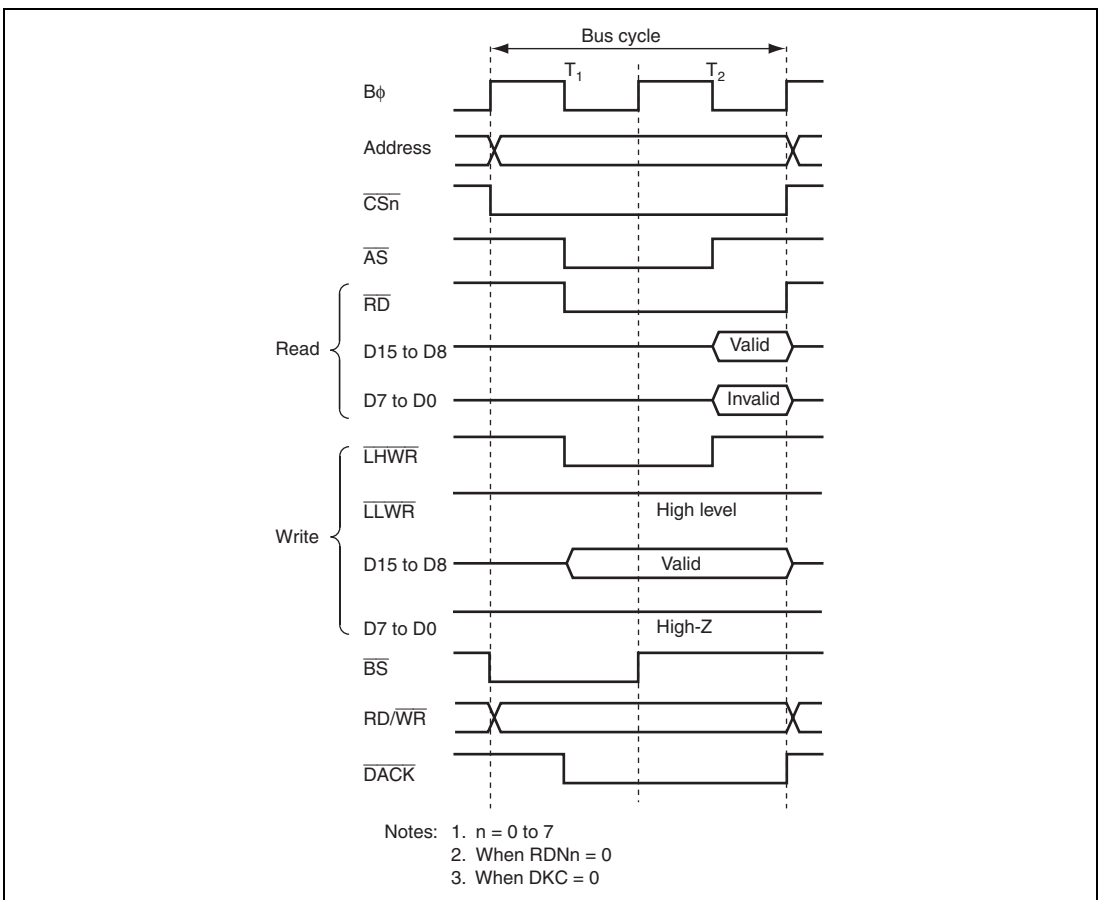

Figure 9.14 16-Bit 2-State Access Space Bus Timing (Byte Access for Even Address)

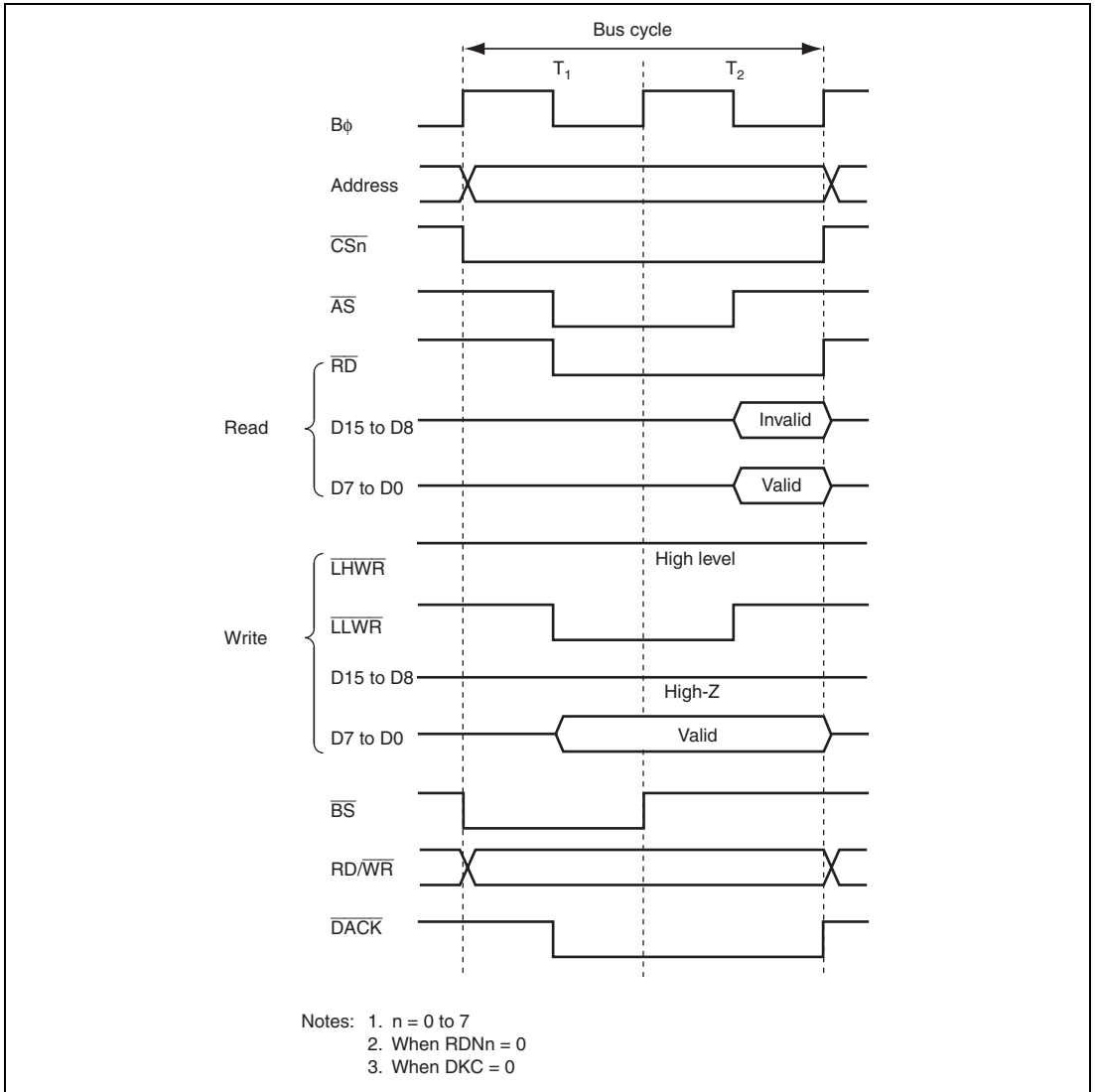

Figure 9.15 16-Bit 2-State Access Space Bus Timing (Byte Access for Odd Address)

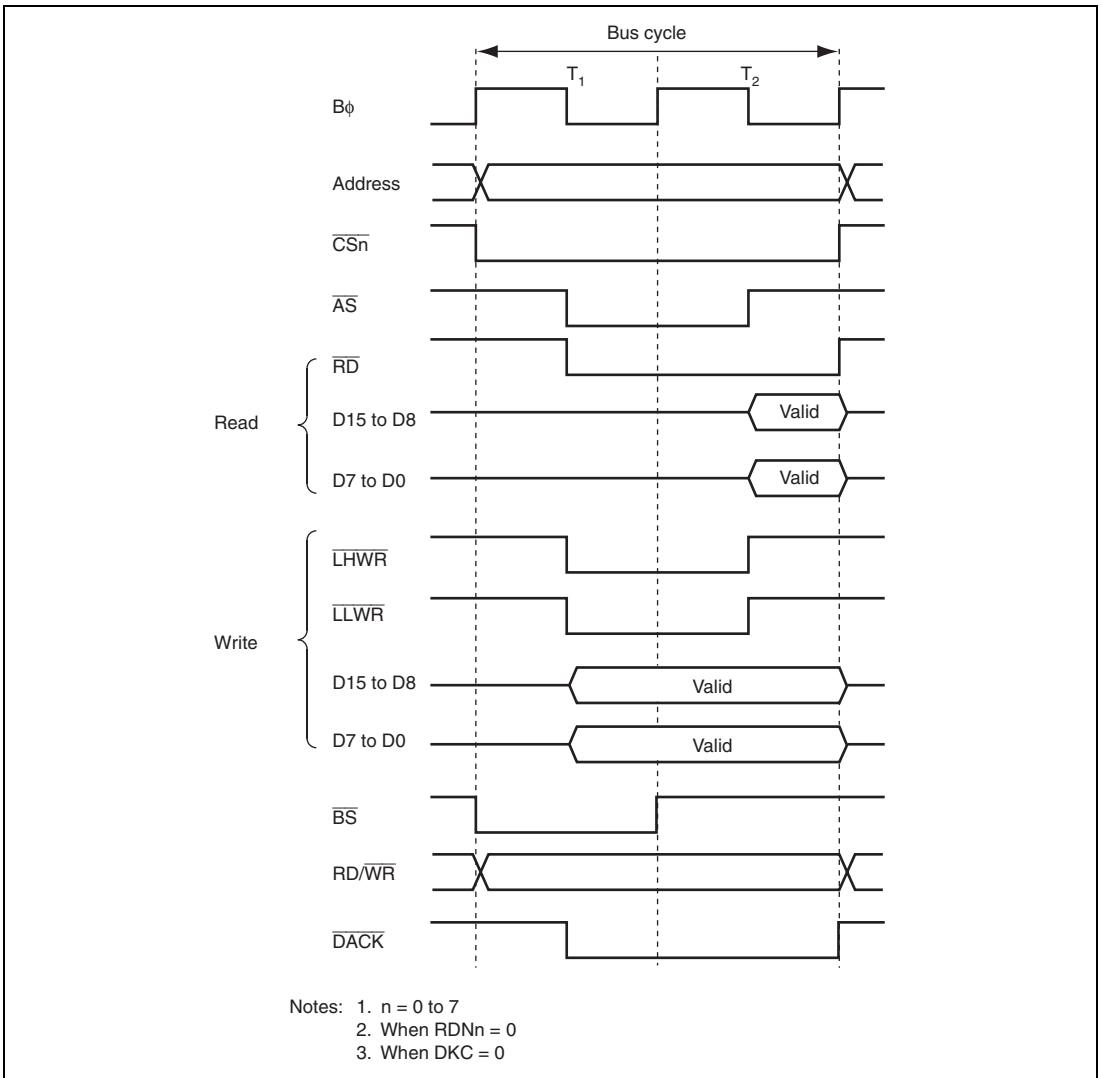

Figure 9.16 16-Bit 2-State Access Space Bus Timing (Word Access for Even Address)

(2) 16-Bit 3-State Access Space

Figures 9.17 to 9.19 show the bus timing of 16-bit 3-state access space.

When accessing 16-bit access space, the upper byte data bus (D15 to D8) is used for even addresses, and the lower byte data bus (D7 to D0) is used for odd addresses. Wait cycles can be inserted.

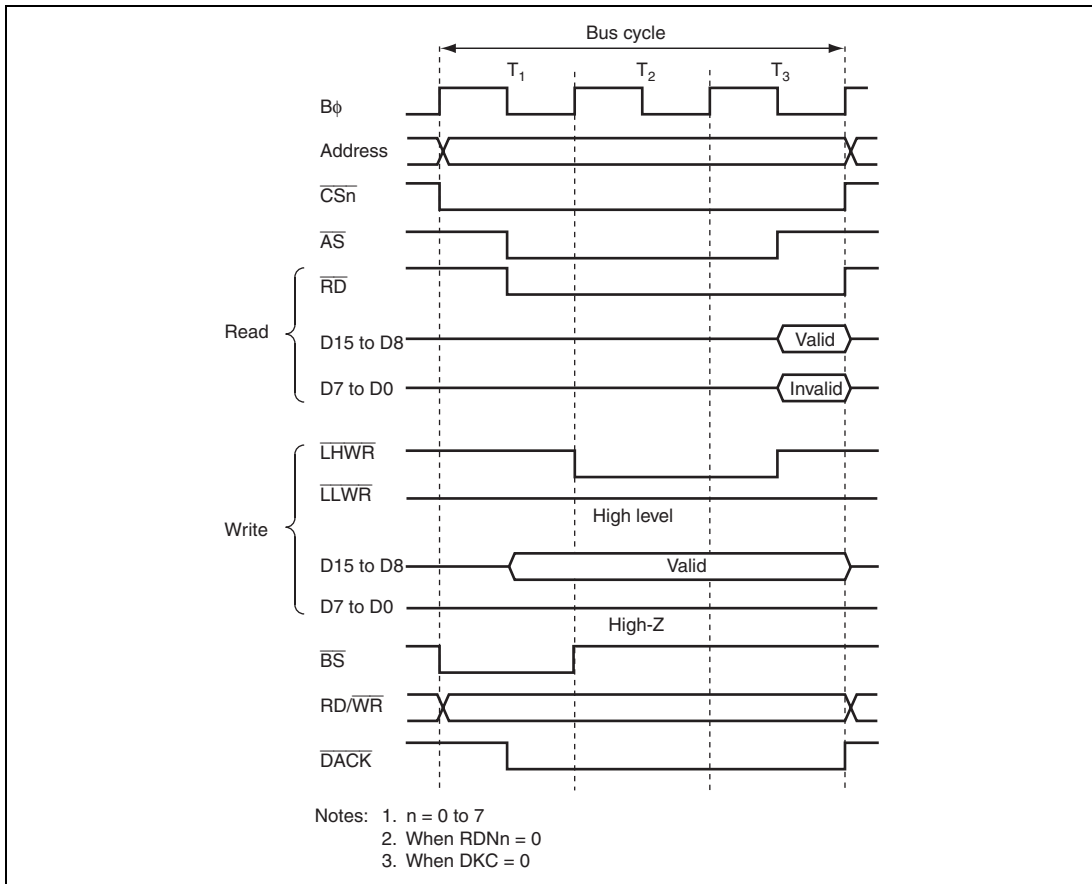

Figure 9.17 16-Bit 3-State Access Space Bus Timing (Byte Access for Even Address)

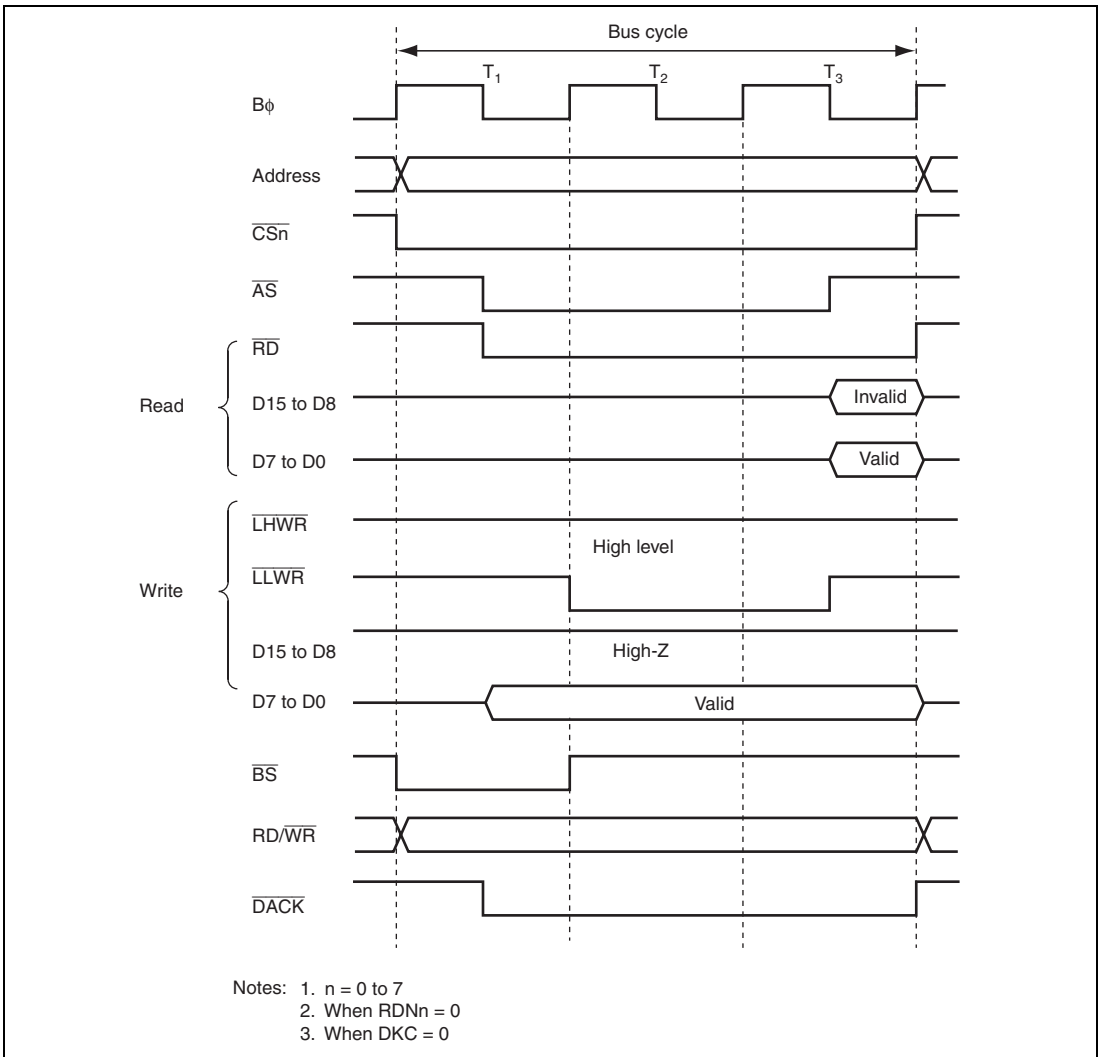

Figure 9.18 16-Bit 3-State Access Space Bus Timing (Word Access for Odd Address)

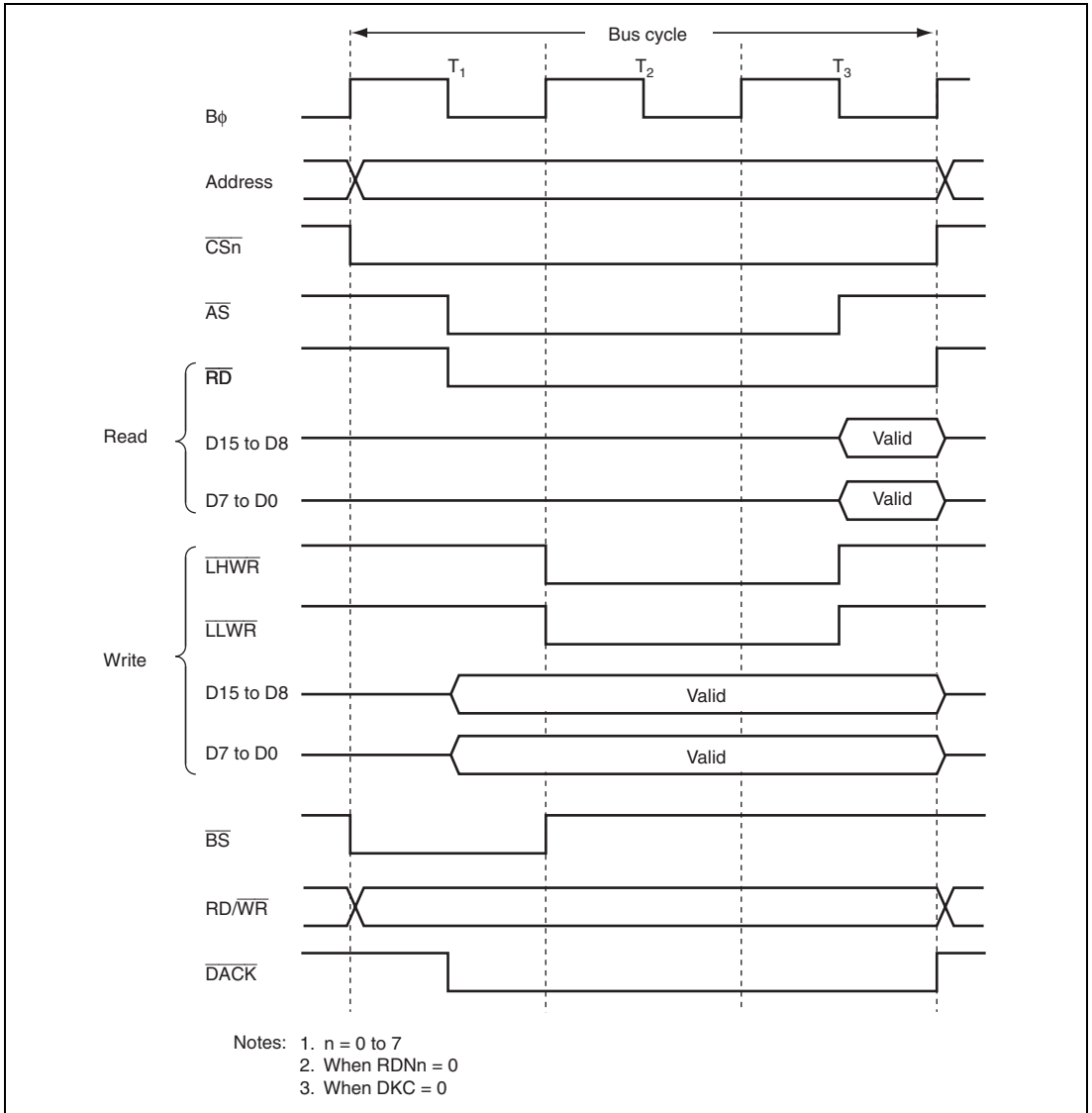

Figure 9.19 16-Bit 3-State Access Space Bus Timing (Word Access for Even Address)

9.6.4 Wait Control

This LSI can extend the bus cycle by inserting wait cycles (T_w) when the external address space is accessed. There are two ways of inserting wait cycles: program wait (T_{pw}) insertion and pin wait (T_{tw}) insertion using the $\overline{\text{WAIT}}$ pin.

(1) Program Wait Insertion

From 0 to 7 wait cycles can be inserted automatically between the T_2 state and T_3 state for 3-state access space, according to the settings in WTCRA and WTCRB.

(2) Pin Wait Insertion

For 3-state access space, when the WAITE bit in BCR1 is set to 1 and the corresponding ICR bit is set to 1, wait input by means of the $\overline{\text{WAIT}}$ pin is enabled. When the external address space is accessed in this state, a program wait (T_{pw}) is first inserted according to the WTCRA and WTCRB settings. If the $\overline{\text{WAIT}}$ pin is low at the falling edge of $B\phi$ in the last T_2 or T_{pw} cycle, another T_{tw} cycle is inserted until the $\overline{\text{WAIT}}$ pin is brought high. The pin wait insertion is effective when the T_w cycles are inserted to seven cycles or more, or when the number of T_w cycles to be inserted is changed according to the external devices. The WAITE bit is common to all areas. For details on ICR, see section 12, I/O Ports.

Figure 9.20 shows an example of wait cycle insertion timing. After a reset, the 3-state access is specified, the program wait is inserted for seven cycles, and the $\overline{\text{WAIT}}$ input is disabled.

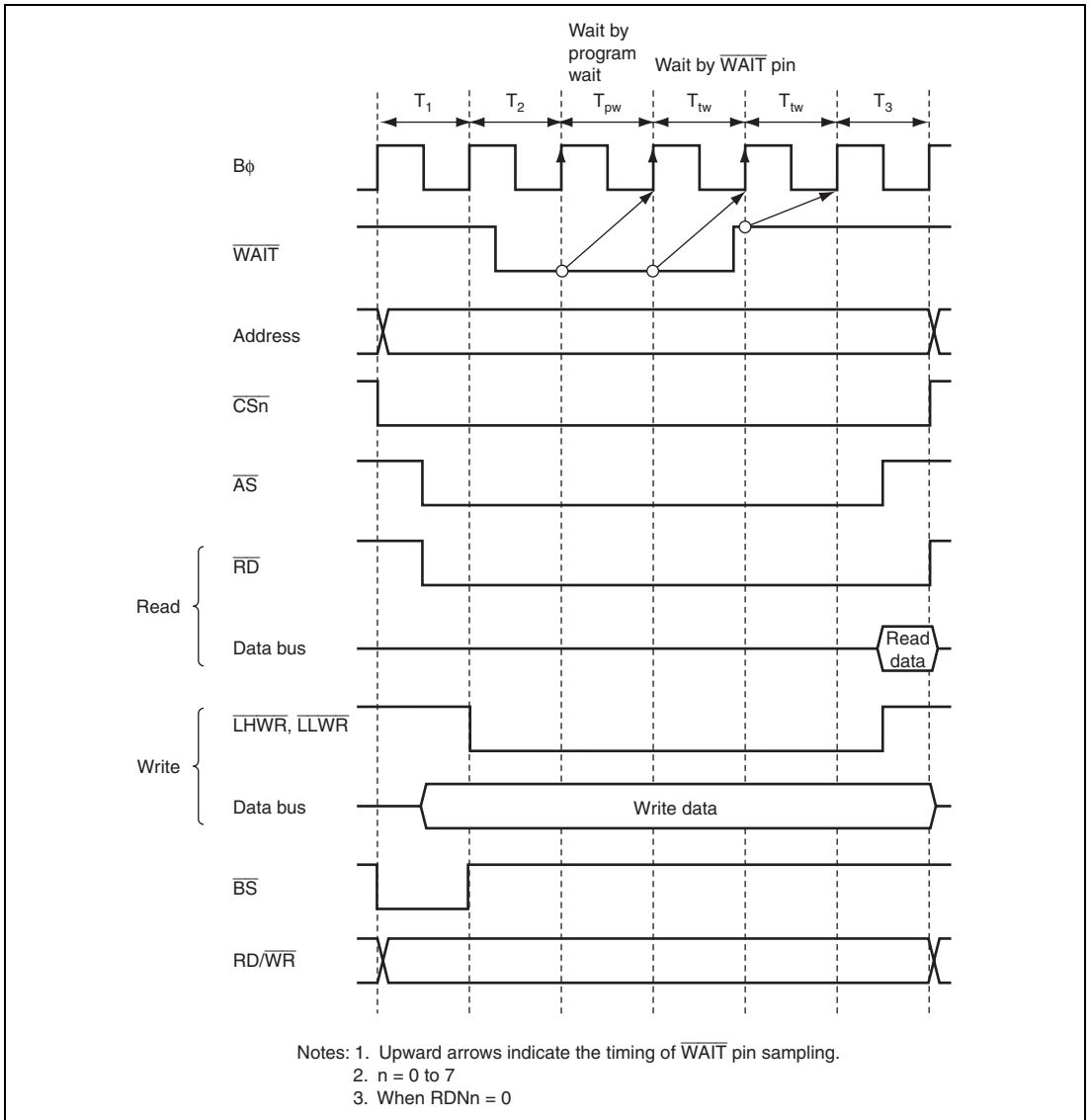

Figure 9.20 Example of Wait Cycle Insertion Timing

9.6.5 Read Strobe (\overline{RD}) Timing

The read strobe timing can be modified in area units by setting bits RDN7 to RDN0 in RDNCR to 1.

Note that the \overline{RD} timing with respect to the \overline{DACK} rising edge will change if the read strobe timing is modified by setting RDNn to 1 when the DMAC is used in the single address mode.

Figure 9.21 shows an example of timing when the read strobe timing is changed in the basic bus 3-state access space.

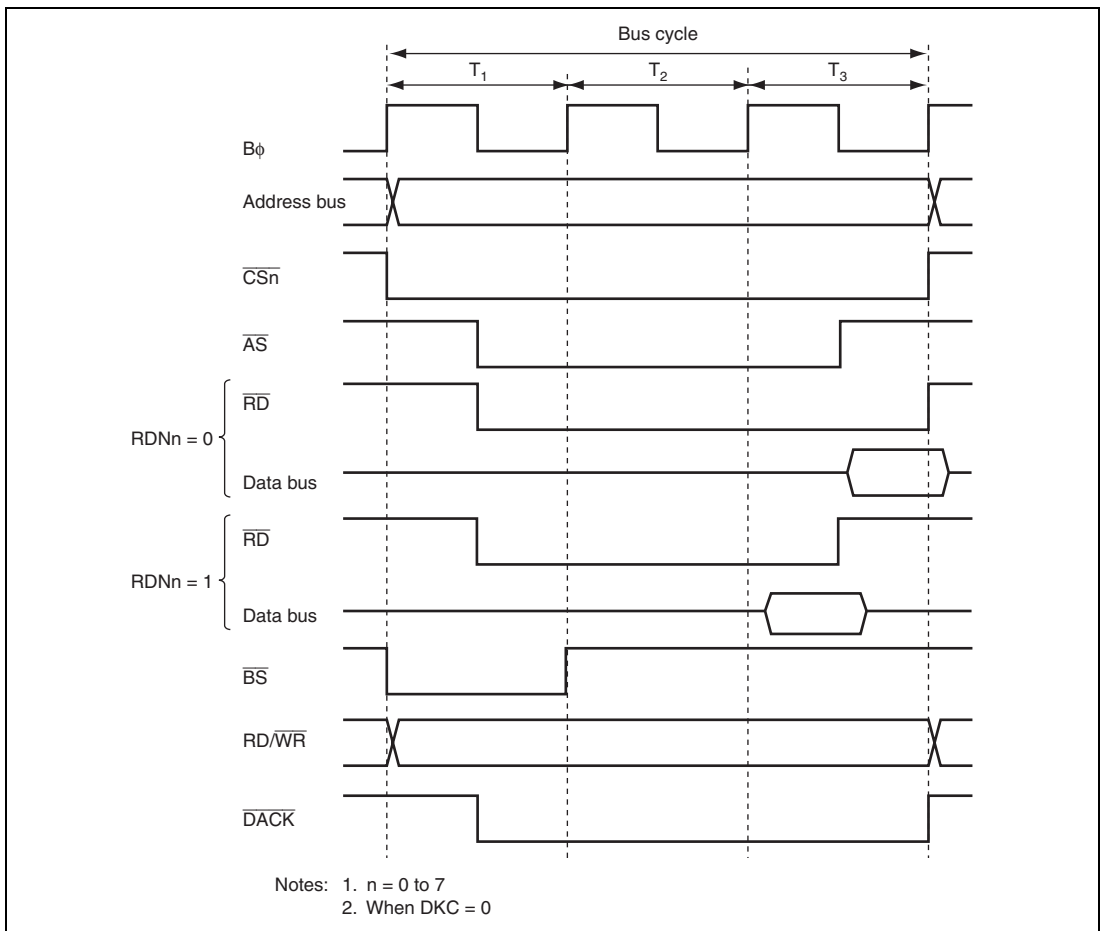

Figure 9.21 Example of Read Strobe Timing

9.6.6 Extension of Chip Select (\overline{CS}) Assertion Period

Some external I/O devices require a setup time and hold time between address and \overline{CS} signals and strobe signals such as \overline{RD} , \overline{LHWR} , and \overline{LLWR} .

Settings can be made in CSACR to insert cycles in which only the \overline{CS} , \overline{AS} , and address signals are asserted before and after a basic bus space access cycle. Extension of the \overline{CS} assertion period can be set in area units. With the \overline{CS} assertion extension period in write access, the data setup and hold times are less stringent since the write data is output to the data bus.

Figure 9.22 shows an example of the timing when the \overline{CS} assertion period is extended in basic bus 3-state access space.

Both extension cycle T_h inserted before the basic bus cycle and extension cycle T_t inserted after the basic bus cycle, or only one of these, can be specified for individual areas. Insertion or non-insertion can be specified for the T_h cycle with the upper eight bits (CSXH7 to CSXH0) in CSACR, and for the T_t cycle with the lower eight bits (CSXT7 to CSXT0).

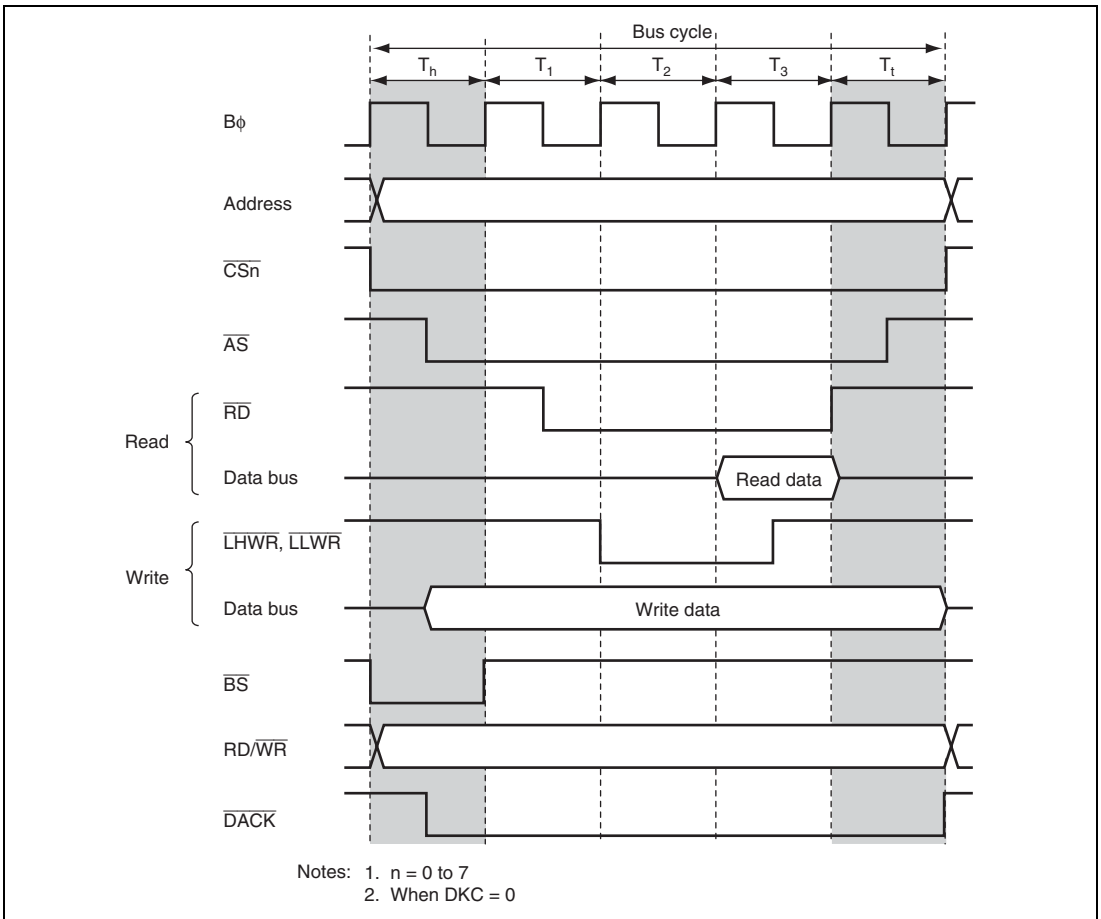

Figure 9.22 Example of Timing when Chip Select Assertion Period is Extended

9.6.7 $\overline{\text{DACK}}$ Signal Output Timing

For DMAC single address transfers, the $\overline{\text{DACK}}$ signal assert timing can be modified by using the DKC bit in BCR1.

Figure 9.23 shows the $\overline{\text{DACK}}$ signal output timing. Setting the DKC bit to 1 asserts the $\overline{\text{DACK}}$ signal a half cycle earlier.

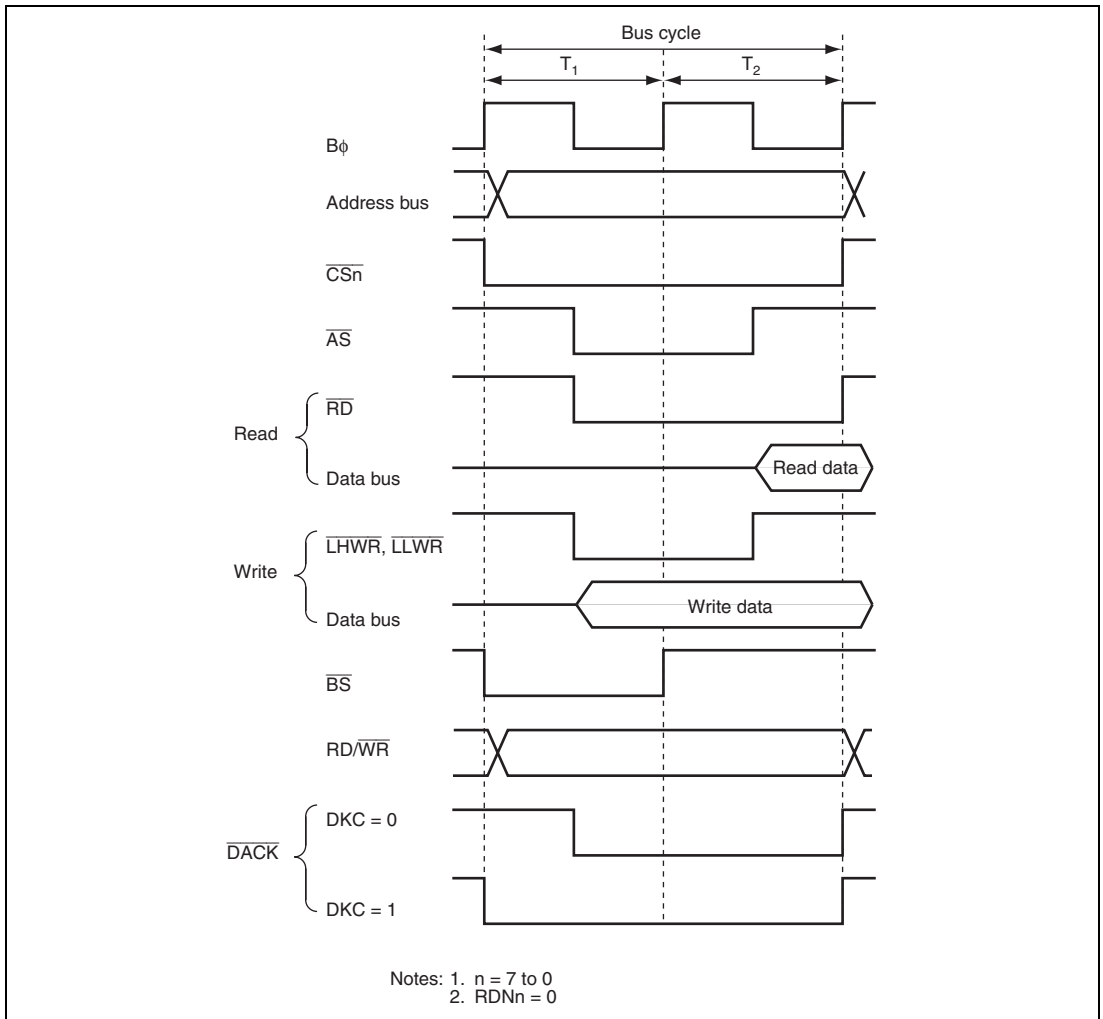

Figure 9.23 $\overline{\text{DACK}}$ Signal Output Timing

9.7 Byte Control SRAM Interface

The byte control SRAM interface is a memory interface for outputting a byte select strobe during a read or a write bus cycle. This interface has 16-bit data input/output pins and can be connected to the SRAM that has the upper byte select and the lower byte select strobes such as \overline{UB} and \overline{LB} .

The operation of the byte control SRAM interface is the same as the basic bus interface except that: the byte select strobes (\overline{LUB} and \overline{LLB}) are output from the write strobe output pins (\overline{LHWR} and \overline{LLWR}), respectively; the read strobe (\overline{RD}) negation timing is a half cycle earlier than that in the case where $RDNn = 0$ in the basic bus interface regardless of the $RDNCR$ settings; and the $\overline{RD}/\overline{WR}$ signal is used as write enable.

9.7.1 Byte Control SRAM Space Setting

Byte control SRAM interface can be specified for areas 0 to 7. Each area can be specified as byte control SRAM interface by setting bits $BCSELn$ ($n = 0$ to 7) in $SRAMCR$. For the area specified as burst ROM interface or address/data multiplexed I/O interface, the $SRAMCR$ setting is invalid and byte control SRAM interface cannot be used.

9.7.2 Data Bus

The bus width of the byte control SRAM space can be specified as 16-bit byte control SRAM space according to bits $ABWHn$ and $ABWLn$ ($n = 0$ to 7) in $ABWCR$. The area specified as 8-bit access space cannot be specified as the byte control SRAM space.

For the 16-bit byte control SRAM space, data bus (D15 to D0) is valid.

Access size and data alignment are the same as the basic bus interface. For details, see section 9.5.6, Endian and Data Alignment.

9.7.3 I/O Pins Used for Byte Control SRAM Interface

Table 9.16 shows the pins used for the byte control SRAM interface.

In the byte control SRAM interface, write strobe signals ($\overline{\text{LHWR}}$ and $\overline{\text{LLWR}}$) are output from the byte select strobes. The $\text{RD}/\overline{\text{WR}}$ signal is used as a write enable signal.

Table 9.16 I/O Pins for Byte Control SRAM Interface

Pin	When Byte Control SRAM is Specified	Name	I/O	Function
$\overline{\text{AS/AH}}$	$\overline{\text{AS}}$	Address strobe	Output	Strobe signal indicating that the address output on the address bus is valid when a basic bus interface space or byte control SRAM space is accessed
$\overline{\text{CSn}}$	$\overline{\text{CSn}}$	Chip select	Output	Strobe signal indicating that area n is selected
$\overline{\text{RD}}$	$\overline{\text{RD}}$	Read strobe	Output	Output enable for the SRAM when the byte control SRAM space is accessed
$\text{RD}/\overline{\text{WR}}$	$\text{RD}/\overline{\text{WR}}$	Read/write	Output	Write enable signal for the SRAM when the byte control SRAM space is accessed
$\overline{\text{LHWR/LUB}}$	$\overline{\text{LUB}}$	Lower-upper byte select	Output	Upper byte select when the 16-bit byte control SRAM space is accessed
$\overline{\text{LLWR/LLB}}$	$\overline{\text{LLB}}$	Lower-lower byte select	Output	Lower byte select when the 16-bit byte control SRAM space is accessed
$\overline{\text{WAIT}}$	$\overline{\text{WAIT}}$	Wait	Input	Wait request signal used when an external address space is accessed
A20 to A0	A20 to A0	Address pin	Output	Address output pin
D15 to D0	D15 to D0	Data pin	Input/output	Data input/output pin

9.7.4 Basic Timing

(1) 2-State Access Space

Figure 9.24 shows the bus timing when the byte control SRAM space is specified as a 2-state access space.

Data buses used for 16-bit access space is the same as those in basic bus interface. No wait cycles can be inserted.

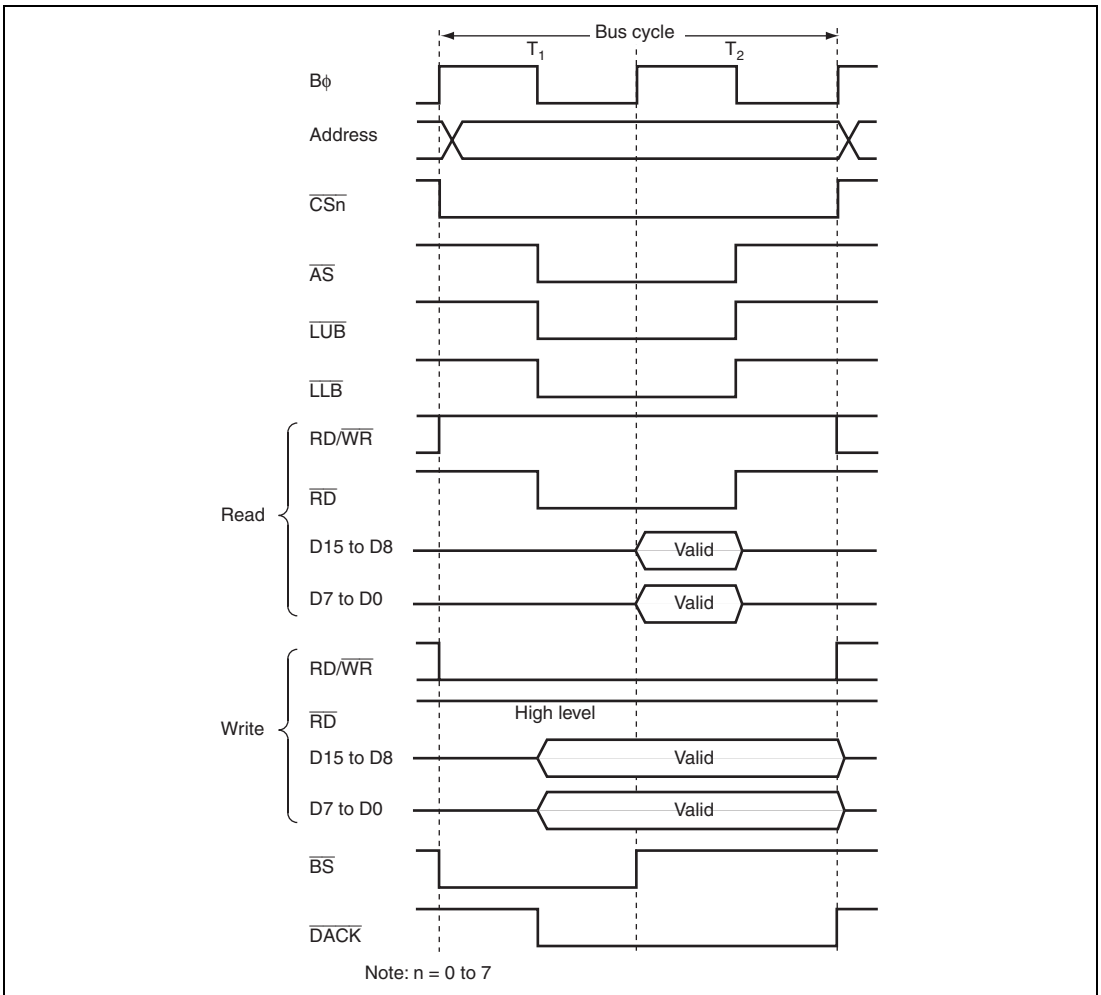

Figure 9.24 16-Bit 2-State Access Space Bus Timing

(2) 3-State Access Space

Figure 9.25 shows the bus timing when the byte control SRAM space is specified as a 3-state access space.

Data buses used for 16-bit access space is the same as those in the basic bus interface. Wait cycles can be inserted.

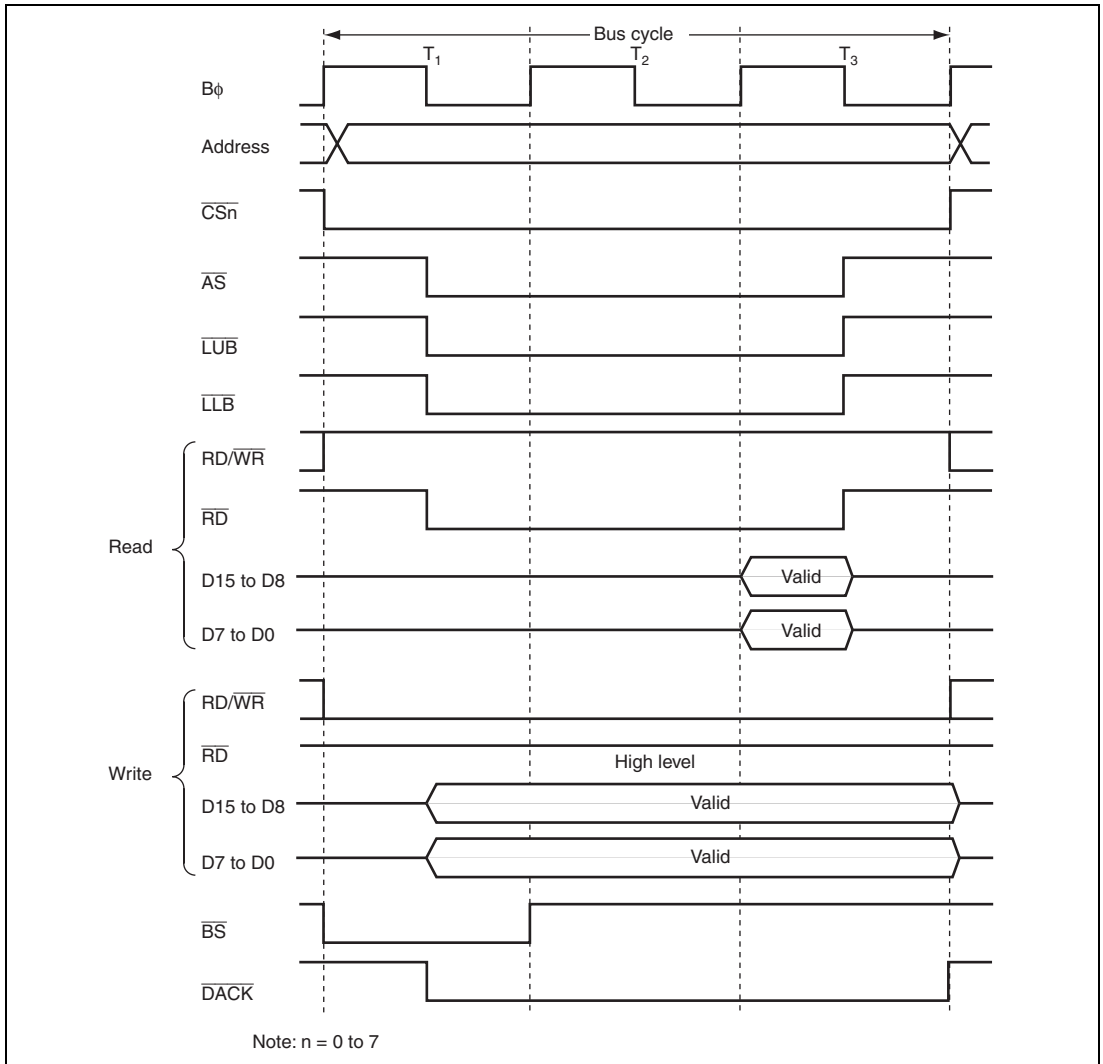

Figure 9.25 16-Bit 3-State Access Space Bus Timing

9.7.5 Wait Control

The bus cycle can be extended for the byte control SRAM interface by inserting wait cycles (T_w) in the same way as the basic bus interface.

(1) Program Wait Insertion

From 0 to 7 wait cycles can be inserted automatically between T2 cycle and T3 cycle for the 3-state access space in area units, according to the settings in WTCRA and WTCRB.

(2) Pin Wait Insertion

For 3-state access space, when the WAITE bit in BCR1 is set to 1, the corresponding DDR bit is cleared to 0, and the ICR bit is set to 1, wait input by means of the $\overline{\text{WAIT}}$ pin is enabled. For details on DDR and ICR, see section 12, I/O Ports.

Figure 9.26 shows an example of wait cycle insertion timing.

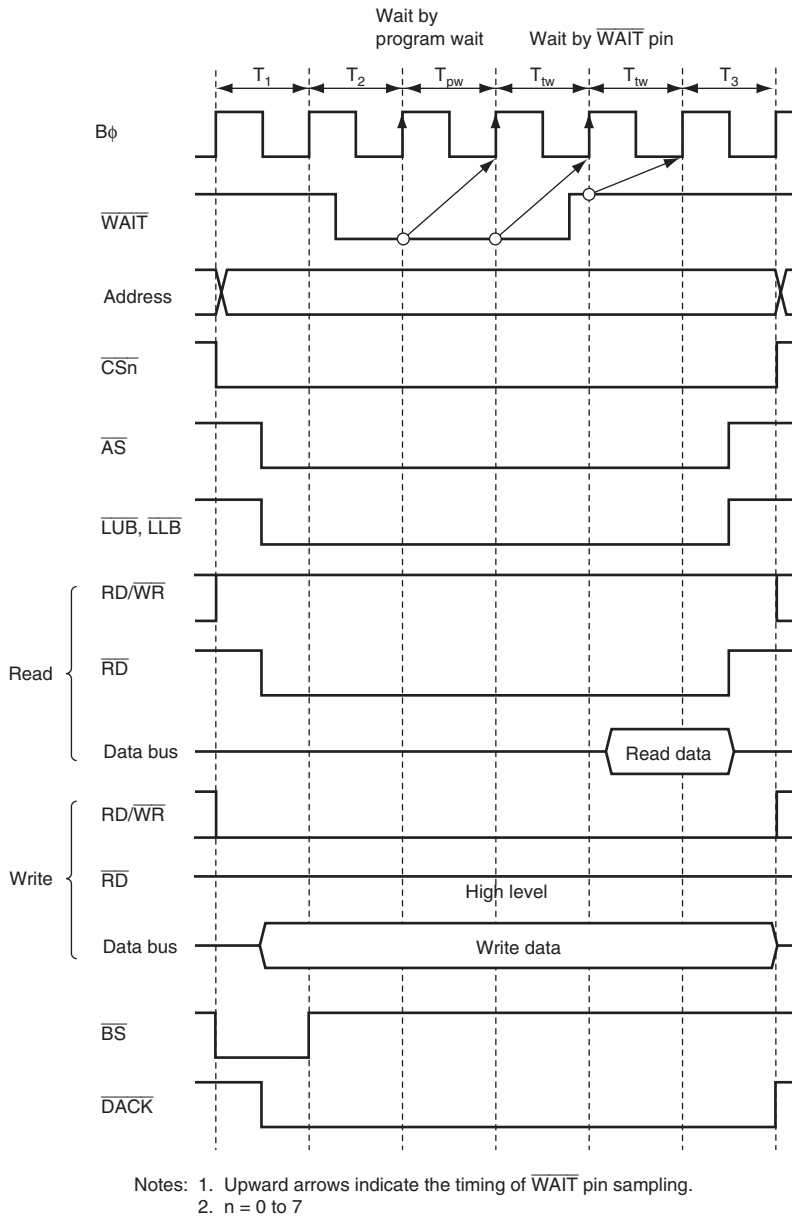

Figure 9.26 Example of Wait Cycle Insertion Timing

9.7.6 Read Strobe ($\overline{\text{RD}}$)

When the byte control SRAM space is specified, the RDNCR setting for the corresponding space is invalid.

The read strobe negation timing is the same timing as when $\text{RDNn} = 1$ in the basic bus interface. Note that the $\overline{\text{RD}}$ timing with respect to the $\overline{\text{DACK}}$ rising edge becomes different.

9.7.7 Extension of Chip Select ($\overline{\text{CS}}$) Assertion Period

In the byte control SRAM interface, the extension cycles can be inserted before and after the bus cycle in the same way as the basic bus interface. For details, see section 9.6.6, Extension of Chip Select ($\overline{\text{CS}}$) Assertion Period.

9.7.8 $\overline{\text{DACK}}$ Signal Output Timing

For DMAC single address transfers, the $\overline{\text{DACK}}$ signal assert timing can be modified by using the DKC bit in BCR1.

Figure 9.27 shows the $\overline{\text{DACK}}$ signal output timing. Setting the DKC bit to 1 asserts the $\overline{\text{DACK}}$ signal a half cycle earlier.

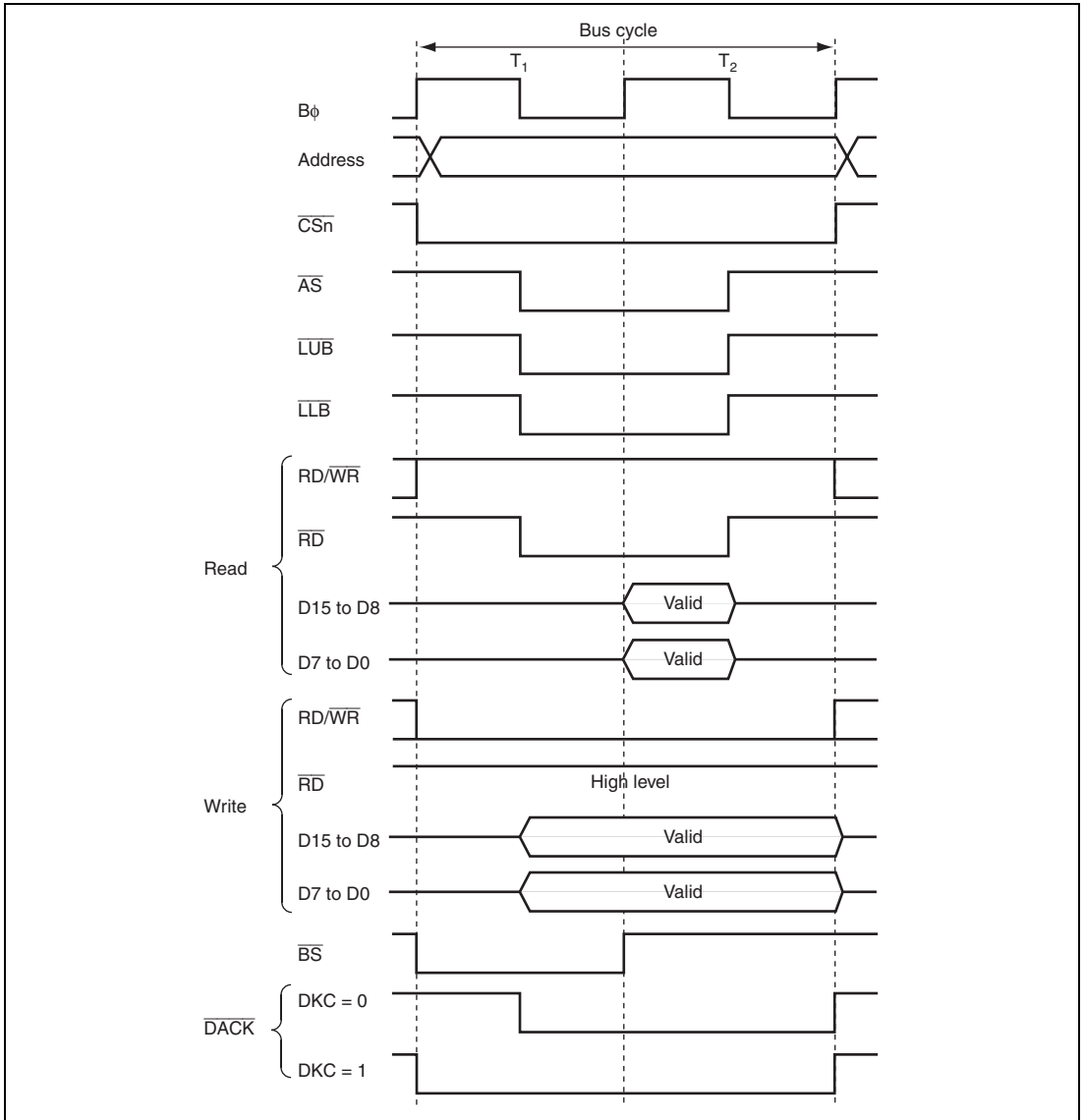

Figure 9.27 $\overline{\text{DACK}}$ Signal Output Timing

9.8 Burst ROM Interface

In this LSI, external address space areas 0 and 1 can be designated as burst ROM space, and burst ROM interfacing performed. The burst ROM interface enables ROM with page access capability to be accessed at high speed.

Areas 1 and 0 can be designated as burst ROM space by means of bits BSRM1 and BSRM0 in BROMCR. Consecutive burst accesses of up to 32 words can be performed, according to the setting of bits BSWDn1 and BSWDn0 ($n = 0, 1$) in BROMCR. From one to eight cycles can be selected for burst access.

Settings can be made independently for area 0 and area 1.

In the burst ROM interface, the burst access covers only CPU read accesses. Other accesses are performed with the similar method to the basic bus interface.

9.8.1 Burst ROM Space Setting

Burst ROM interface can be specified for areas 0 and 1. Areas 0 and 1 can be specified as burst ROM space by setting bits BSRMn ($n = 0, 1$) in BROMCR.

9.8.2 Data Bus

The bus width of the burst ROM space can be specified as 8-bit or 16-bit burst ROM interface space according to the ABWHn and ABWLn bits ($n = 0, 1$) in ABWCR.

For the 8-bit bus width, data bus (D7 to D0) is valid. For the 16-bit bus width, data bus (D15 to D0) is valid.

Access size and data alignment are the same as the basic bus interface. For details, see section 9.5.6, Endian and Data Alignment.

9.8.3 I/O Pins Used for Burst ROM Interface

Table 9.17 shows the pins used for the burst ROM interface.

Table 9.17 I/O Pins Used for Burst ROM Interface

Name	Symbol	I/O	Function
Bus cycle start	\overline{BS}	Output	Signal indicating that the bus cycle has started.
Address strobe	\overline{AS}	Output	Strobe signal indicating that an address output on the address bus is valid during access
Read strobe	\overline{RD}	Output	Strobe signal indicating the read access
Read/write	$\overline{RD}/\overline{WR}$	Output	Signal indicating the data bus input or output direction
Low-high write	\overline{LHWR}	Output	Strobe signal indicating that the upper byte (D15 to D8) is valid during write access
Low-low write	\overline{LLWR}	Output	Strobe signal indicating that the lower byte (D7 to D0) is valid during write access
Chip select 0 to 7	$\overline{CS0}$ to $\overline{CS7}$	Output	Strobe signal indicating that the area is selected
Wait	\overline{WAIT}	Input	Wait request signal used when an external address space is accessed

9.8.4 Basic Timing

The number of access cycles in the initial cycle (full access) on the burst ROM interface is determined by the basic bus interface settings in ABWCR, ASTCR, WTCRA, WTCRB, and bits CSX H_n in CSACR ($n = 0$ to 7). When area 0 or area 1 designated as burst ROM space is read by the CPU, the settings in RDNCR and bits CSXT n in CSACR ($n = 0$ to 7) are ignored.

From one to eight cycles can be selected for the burst cycle, according to the settings of bits BSTS02 to BSTS00 and BSTS12 to BSTS10 in BROMCR. Wait cycles cannot be inserted. In addition, 4-word, 8-word, 16-word, or 32-word consecutive burst access can be performed according to the settings of BSTS01, BSTS00, BSTS11, and BSTS10 bits in BROMCR.

The basic access timing for burst ROM space is shown in figures 9.28 and 9.29.

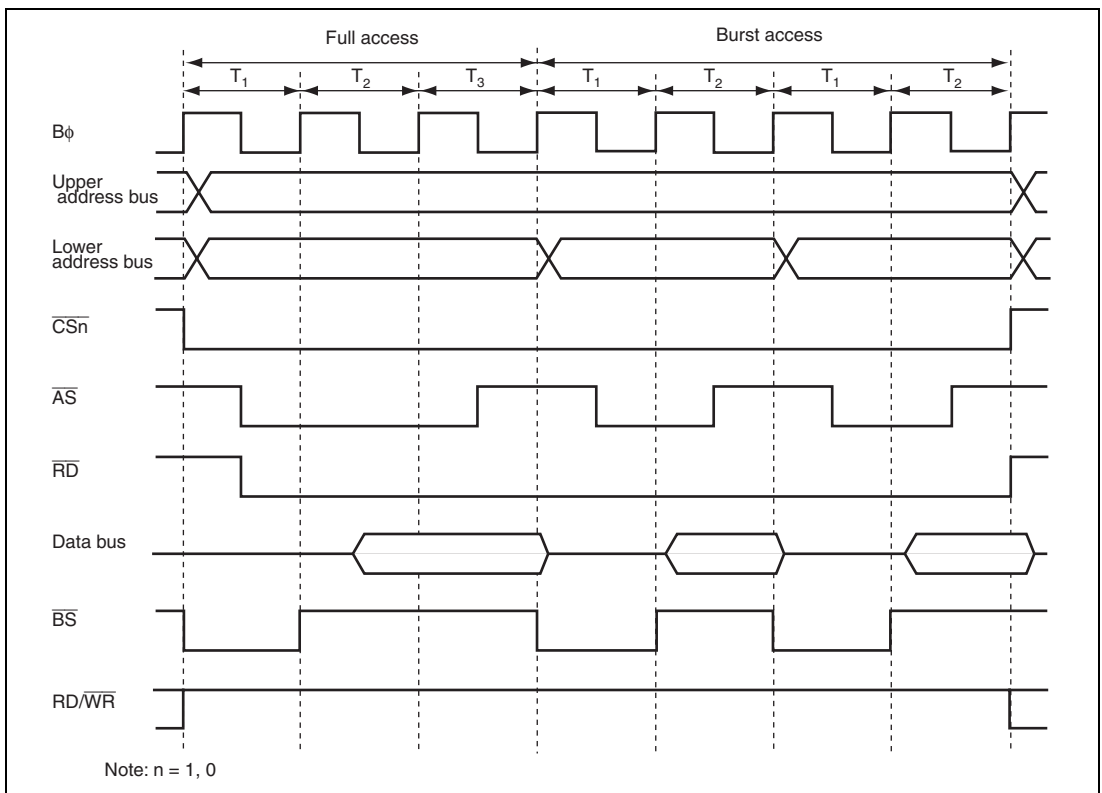

Figure 9.28 Example of Burst ROM Access Timing (AST $n = 1$, Two Burst Cycles)

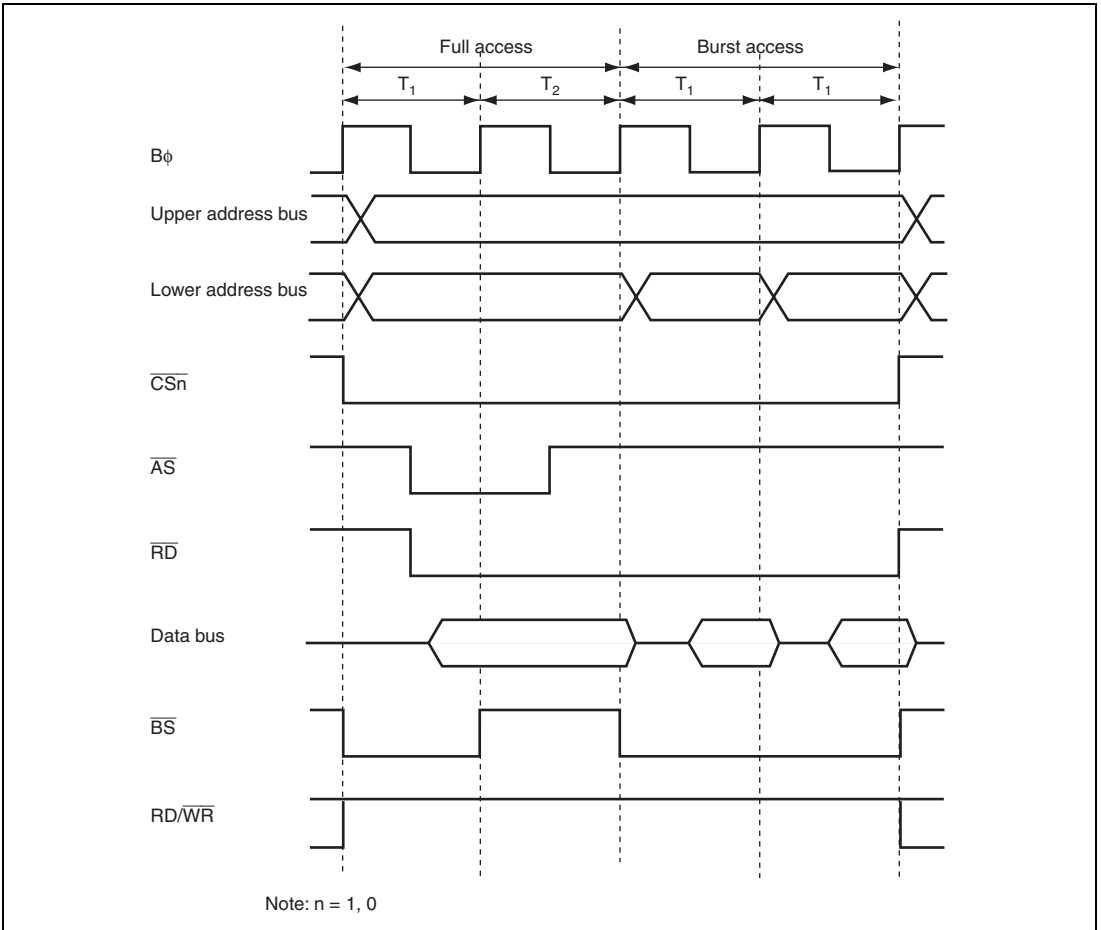

Figure 9.29 Example of Burst ROM Access Timing ($ASTn = 0$, One Burst Cycle)

9.8.5 Wait Control

As with the basic bus interface, either program wait insertion or pin wait insertion by the $\overline{\text{WAIT}}$ pin can be used in the initial cycle (full access) on the burst ROM interface. See section 9.6.4, Wait Control. Wait cycles cannot be inserted in a burst cycle.

9.8.6 Read Strobe ($\overline{\text{RD}}$) Timing

When the burst ROM space is read by the CPU, the RDNCR setting for the corresponding space is invalid.

The read strobe negation timing is the same timing as when $\text{RD}N_n = 0$ in the basic bus interface.

9.8.7 Extension of Chip Select ($\overline{\text{CS}}$) Assertion Period

In the burst ROM interface, the extension cycles can be inserted in the same way as the basic bus interface.

For the burst ROM space, the burst access can be enabled only in read access by the CPU. In this case, the setting of the corresponding CSXT_n bit in CSACR is ignored and an extension cycle can be inserted only before the full access cycle. Note that no extension cycle can be inserted before or after the burst access cycles.

In accesses other than read accesses by the CPU, the burst ROM space is equivalent to the basic bus interface space. Accordingly, extension cycles can be inserted before and after the burst access cycles.

9.9 Address/Data Multiplexed I/O Interface

If areas 3 to 7 of external address space are specified as address/data multiplexed I/O space in this LSI, the address/data multiplexed I/O interface can be performed. In the address/data multiplexed I/O interface, peripheral LSIs that require the multiplexed address/data can be connected directly to this LSI.

9.9.1 Address/Data Multiplexed I/O Space Setting

Address/data multiplexed I/O interface can be specified for areas 3 to 7. Each area can be specified as the address/data multiplexed I/O space by setting bits MPXEn (n = 3 to 7) in MPXCR.

9.9.2 Address/Data Multiplex

In the address/data multiplexed I/O space, data bus is multiplexed with address bus. Table 9.18 shows the relationship between the bus width and address output.

Table 9.18 Address/Data Multiplex

Bus Width	Cycle	Data Pins															
		PI7	PI6	PI5	PI4	PI3	PI2	PI1	PI0	PH7	PH6	PH5	PH4	PH3	PH2	PH1	PH0
8 bits	Address	-	-	-	-	-	-	-	-	A7	A6	A5	A4	A3	A2	A1	A0
	Data	-	-	-	-	-	-	-	-	D7	D6	D5	D4	D3	D2	D1	D0
16 bits	Address	A15	A14	A13	A12	A11	A10	A9	A8	A7	A6	A5	A4	A3	A2	A1	A0
	Data	D15	D14	D13	D12	D11	D10	D9	D8	D7	D6	D5	D4	D3	D2	D1	D0

9.9.3 Data Bus

The bus width of the address/data multiplexed I/O space can be specified for either 8-bit access space or 16-bit access space by the ABWHn and ABWLn bits (n = 3 to 7) in ABWCR.

For the 8-bit access space, D7 to D0 are valid for both address and data. For 16-bit access space, D15 to D0 are valid for both address and data. If the address/data multiplexed I/O space is accessed, the corresponding address will be output to the address bus.

For details on access size and data alignment, see section 9.5.6, Endian and Data Alignment.

9.9.4 I/O Pins Used for Address/Data Multiplexed I/O Interface

Table 9.19 shows the pins used for the address/data multiplexed I/O Interface.

Table 9.19 I/O Pins for Address/Data Multiplexed I/O Interface

Pin	When Byte Control SRAM is Specified	Name	I/O	Function
\overline{CSn}	\overline{CSn}	Chip select	Output	Chip select (n = 3 to 7) when area n is specified as the address/data multiplexed I/O space
$\overline{AS/AH}$	\overline{AH}^*	Address hold	Output	Signal to hold an address when the address/data multiplexed I/O space is specified
\overline{RD}	\overline{RD}	Read strobe	Output	Signal indicating that the address/data multiplexed I/O space is being read
$\overline{LHWR/LUB}$	\overline{LHWR}	Low-high write	Output	Strobe signal indicating that the upper byte (D15 to D8) is valid when the address/data multiplexed I/O space is written
$\overline{LLWR/LLB}$	\overline{LLWR}	Low-low write	Output	Strobe signal indicating that the lower byte (D7 to D0) is valid when the address/data multiplexed I/O space is written
D15 to D0	D15 to D0	Address/data	Input/output	Address and data multiplexed pins for the address/data multiplexed I/O space. Only D7 to D0 are valid when the 8-bit space is specified. D15 to D0 are valid when the 16-bit space is specified.
A20 to A0	A20 to A0	Address	Output	Address output pin
\overline{WAIT}	\overline{WAIT}	Wait	Input	Wait request signal used when the external address space is accessed
\overline{BS}	\overline{BS}	Bus cycle start	Output	Signal to indicate the bus cycle start
$\overline{RD/\overline{WR}}$	$\overline{RD/\overline{WR}}$	Read/write	Output	Signal indicating the data bus input or output direction

Note: * The AH output is multiplexed with the \overline{AS} output. At the timing that an area is specified as address/data multiplexed I/O, this pin starts to function as the AH output meaning that this pin cannot be used as the \overline{AS} output. At this time, when other areas set to the basic bus interface is accessed, this pin does not function as the \overline{AS} output. Until an area is specified as address/data multiplexed I/O, be aware that this pin functions as the \overline{AS} output.

9.9.5 Basic Timing

The bus cycle in the address/data multiplexed I/O interface consists of an address cycle and a data cycle. The data cycle is based on the basic bus interface timing specified by the ABWCR, ASTCR, WTCRA, WTCRB, RDNCR, and CSACR.

Figures 9.30 and 9.31 show the basic access timings.

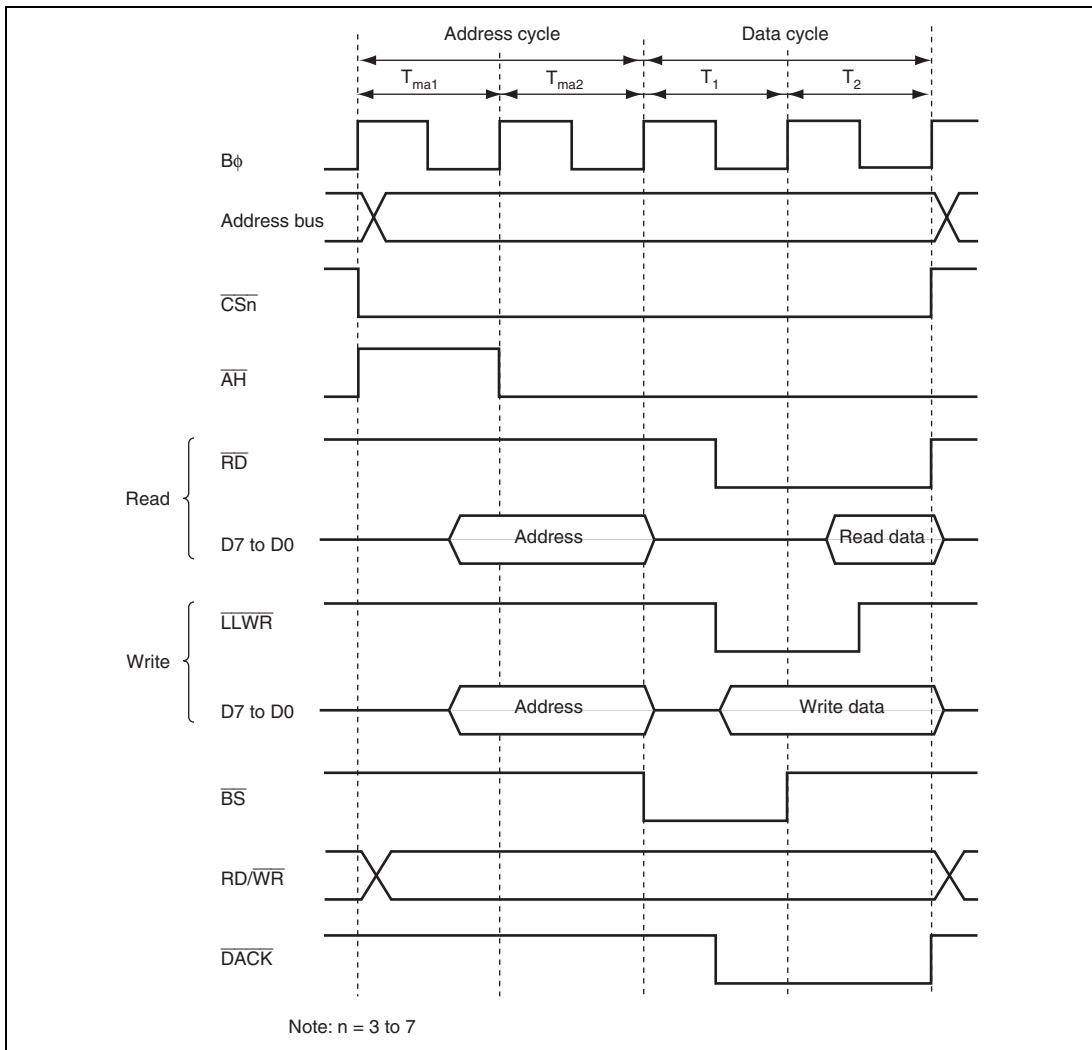

Figure 9.30 8-Bit Access Space Access Timing (ABWH_n = 1, ABWL_n = 1)

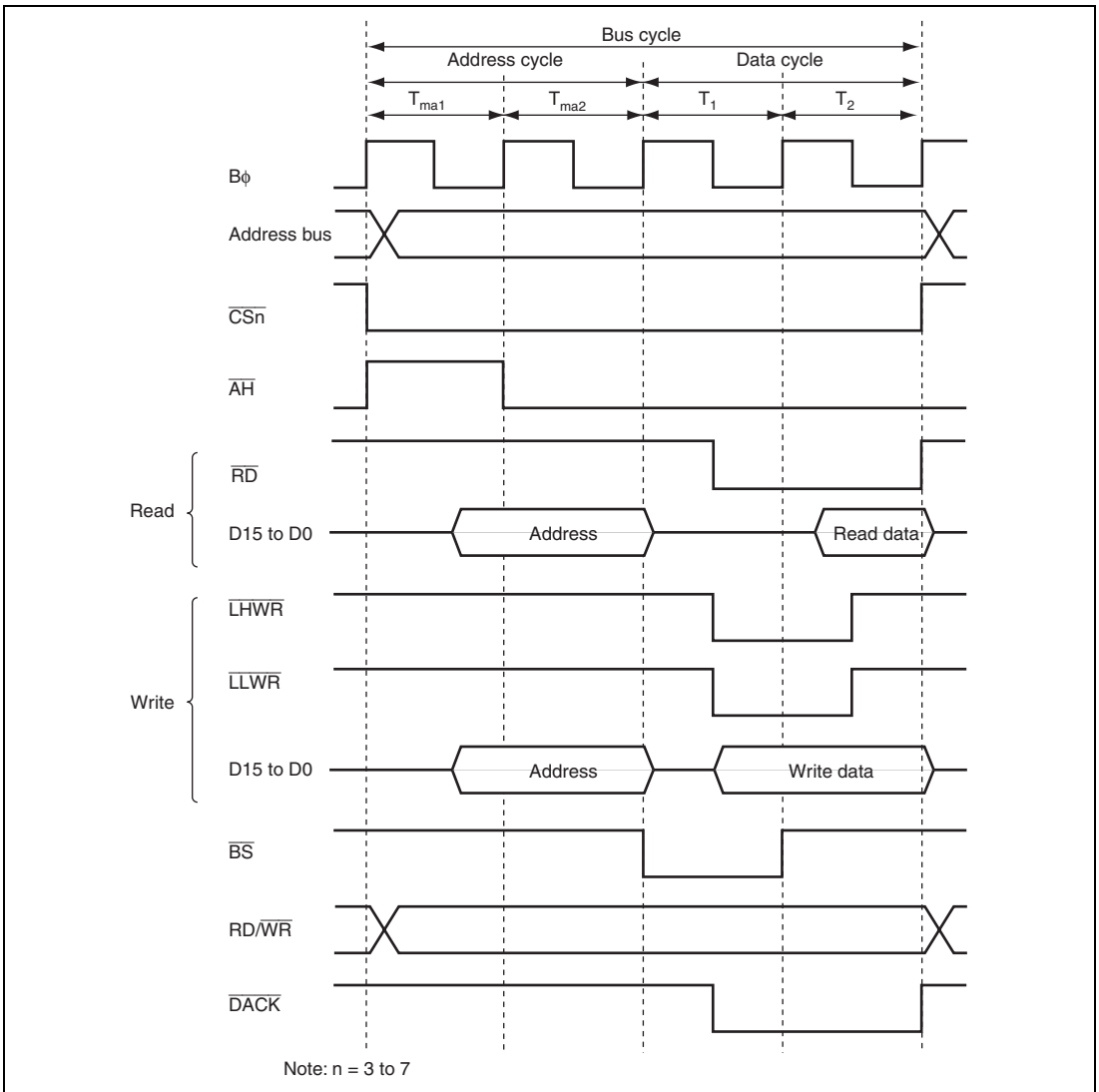

Figure 9.31 16-Bit Access Space Access Timing (ABWH_n = 0, ABWL_n = 1)

9.9.6 Address Cycle Control

An extension cycle (T_{maw}) can be inserted between T_{ma1} and T_{ma2} cycles to extend the \overline{AH} signal output period by setting the \overline{ADDEX} bit in $MPXCR$. By inserting the T_{maw} cycle, the address setup for \overline{AH} and the \overline{AH} minimum pulse width can be assured.

Figure 9.32 shows the access timing when the address cycle is three cycles.

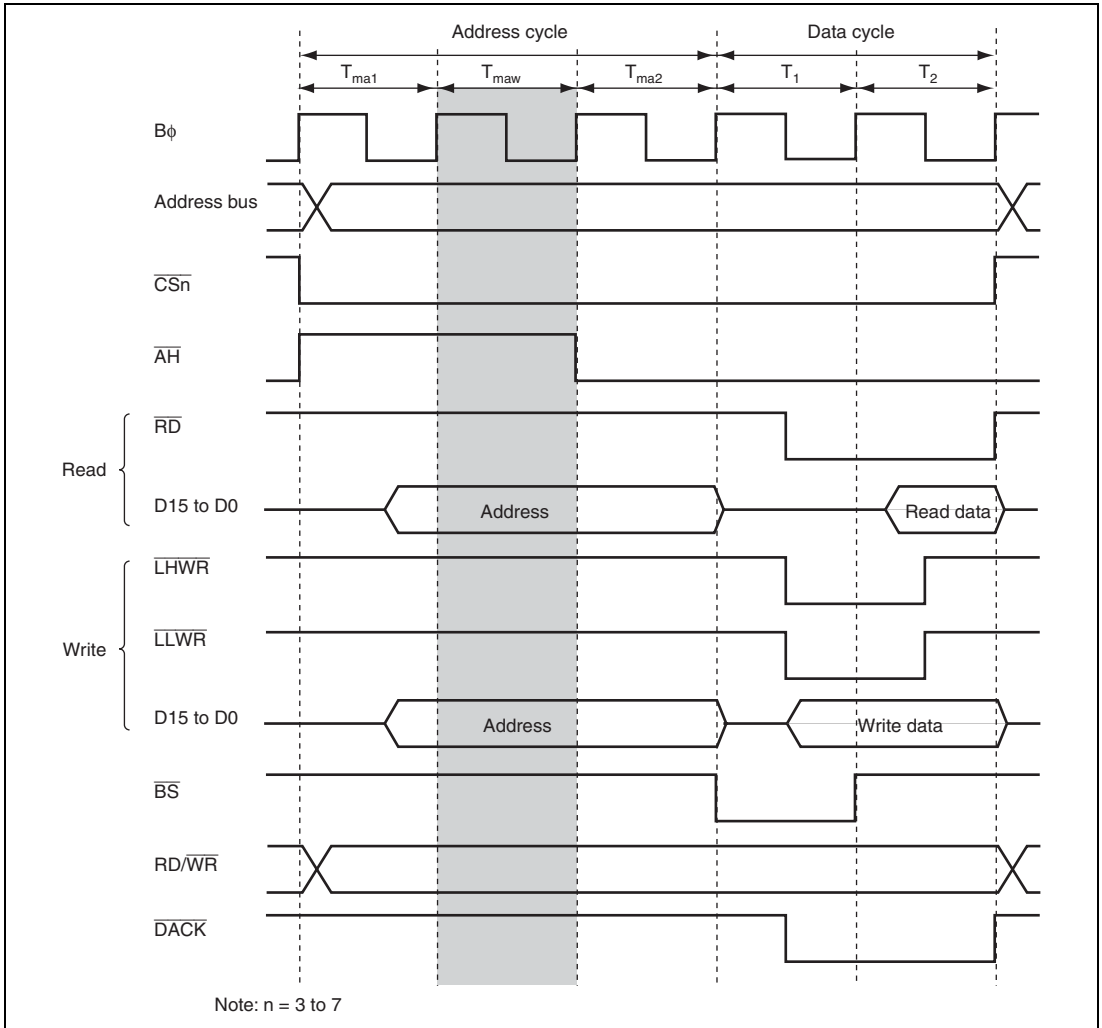

Figure 9.32 Access Timing of 3 Address Cycles ($\overline{ADDEX} = 1$)

9.9.7 Wait Control

In the data cycle of the address/data multiplexed I/O interface, program wait insertion and pin wait insertion by the $\overline{\text{WAIT}}$ pin are enabled in the same way as in the basic bus interface. For details, see section 9.6.4, Wait Control.

Wait control settings do not affect the address cycles.

9.9.8 Read Strobe ($\overline{\text{RD}}$) Timing

In the address/data multiplexed I/O interface, the read strobe timing of data cycles can be modified in the same way as in basic bus interface. For details, see section 9.6.5, Read Strobe ($\overline{\text{RD}}$) Timing.

Figure 9.33 shows an example when the read strobe timing is modified.

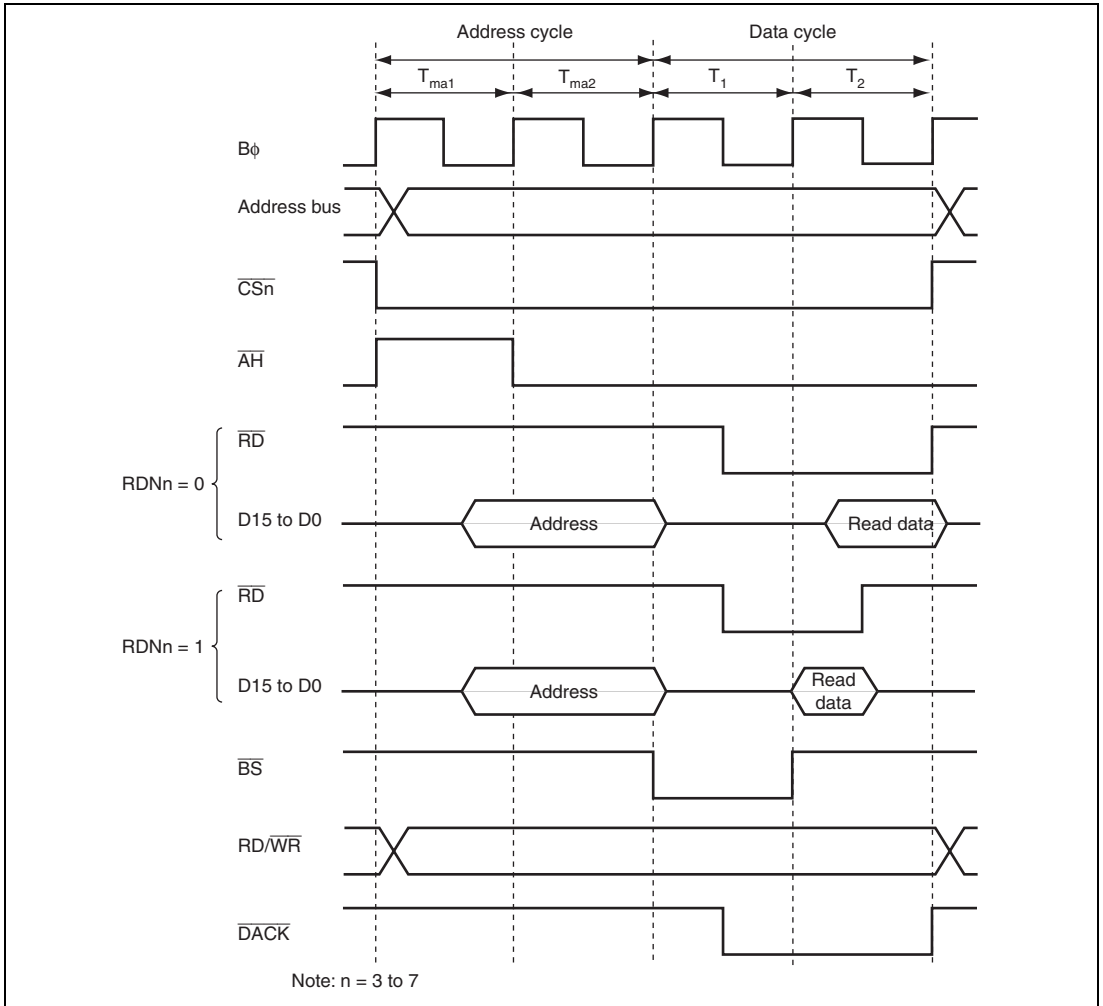

Figure 9.33 Read Strobe Timing

9.9.9 Extension of Chip Select (\overline{CS}) Assertion Period

In the address/data multiplexed interface, the extension cycles can be inserted before and after the bus cycle. For details, see section 9.6.6, Extension of Chip Select (\overline{CS}) Assertion Period.

Figure 9.34 shows an example of the chip select (\overline{CS}) assertion period extension timing.

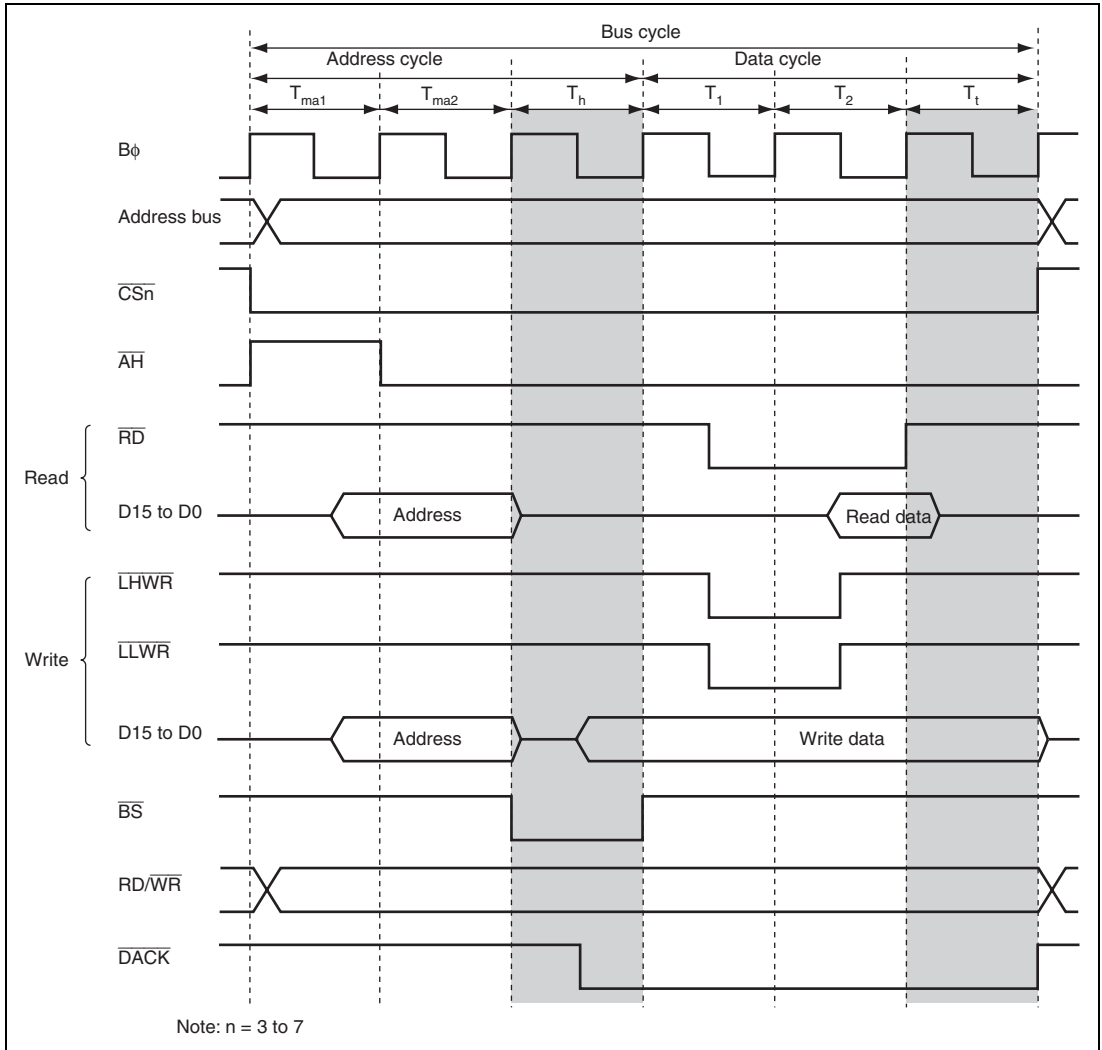
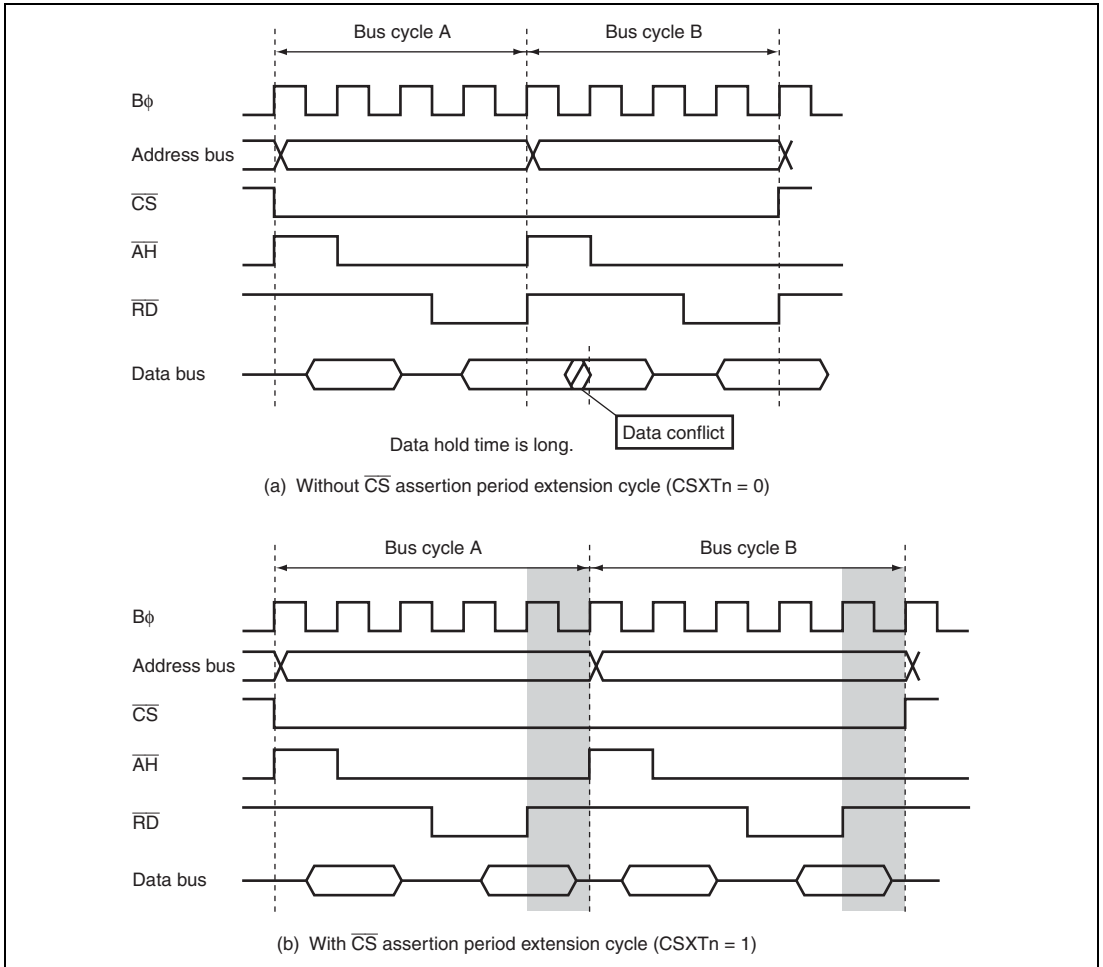

Figure 9.34 Chip Select (\overline{CS}) Assertion Period Extension Timing in Data Cycle

When consecutively reading from the same area connected to a peripheral LSI whose data hold time is long, data outputs from the peripheral LSI and this LSI may conflict. Inserting the chip select assertion period extension cycle after the access cycle can avoid the data conflict.

Figure 9.35 shows an example of the operation. In the figure, both bus cycles A and B are read access cycles to the address/data multiplexed I/O space. An example of the data conflict is shown in (a), and an example of avoiding the data conflict by the $\overline{\text{CS}}$ assertion period extension cycle in (b).



**Figure 9.35 Consecutive Read Accesses to Same Area
(Address/Data Multiplexed I/O Space)**

9.9.10 $\overline{\text{DACK}}$ Signal Output Timing

For DMAC single address transfers, the $\overline{\text{DACK}}$ signal assert timing can be modified by using the DKC bit in BCR1.

Figure 9.36 shows the $\overline{\text{DACK}}$ signal output timing. Setting the DKC bit to 1 asserts the $\overline{\text{DACK}}$ signal a half cycle earlier.

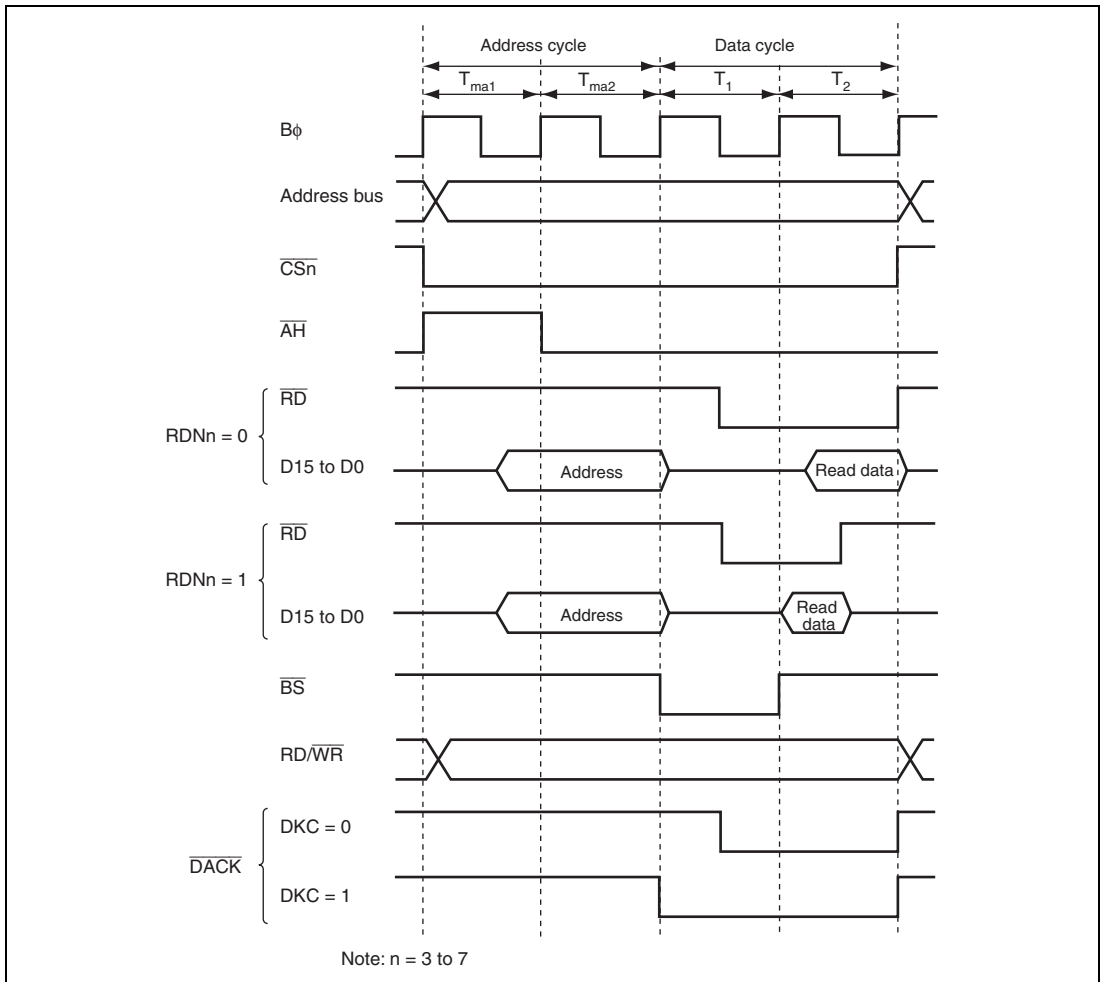

Figure 9.36 $\overline{\text{DACK}}$ Signal Output Timing

9.10 Idle Cycle

In this LSI, idle cycles can be inserted between the consecutive external accesses. By inserting the idle cycle, data conflicts between ROM read cycle whose output floating time is long and an access cycle from/to high-speed memory or I/O interface can be prevented.

9.10.1 Operation

When this LSI consecutively accesses external address space, it can insert an idle cycle between bus cycles in the following four cases. These conditions are determined by the sequence of read and write and previously accessed area.

1. When read cycles of different areas in the external address space occur consecutively
2. When an external write cycle occurs immediately after an external read cycle
3. When an external read cycle occurs immediately after an external write cycle
4. When an external access occurs immediately after a DMAC single address transfer (write cycle)

Up to four idle cycles can be inserted under the conditions shown above. The number of idle cycles to be inserted should be specified to prevent data conflicts between the output data from a previously accessed device and data from a subsequently accessed device.

Under conditions 1 and 2, which are the conditions to insert idle cycles after read, the number of idle cycles can be selected from setting A specified by bits IDLCA1 and IDLCA0 in IDLCR or setting B specified by bits IDLCB1 and IDLCB0 in IDLCR: Setting A can be selected from one to four cycles, and setting B can be selected from one or two to four cycles. Setting A or B can be specified for each area by setting bits IDLSEL7 to IDLSEL0 in IDLCR. Note that bits IDLSEL7 to IDLSEL0 correspond to the previously accessed area of the consecutive accesses.

The number of idle cycles to be inserted under conditions 3 and 4, which are conditions to insert idle cycles after write, can be determined by setting A as described above.

After the reset release, IDLCR is initialized to four idle cycle insertion under all conditions 1 to 4 shown above.

Table 9.20 shows the correspondence between conditions 1 to 4 and number of idle cycles to be inserted for each area. Table 9.21 shows the correspondence between the number of idle cycles to be inserted specified by settings A and B, and number of cycles to be inserted.

Table 9.20 Number of Idle Cycle Insertion Selection in Each Area

Insertion Condition	Bit Settings		Area for Previous Access								
	n	IDLSn	IDLSELn n = 0 to 7	0	1	2	3	4	5	6	7
		Setting									
Consecutive reads in different areas	1	0	—	Invalid							
		1	0	A	A	A	A	A	A	A	A
			1	B	B	B	B	B	B	B	B
Write after read	0	0	—	Invalid							
		1	0	A	A	A	A	A	A	A	
			1	B	B	B	B	B	B	B	
Read after write	2	0	—	Invalid							
		1		A							
External access after single address transfer	3	0	—	Invalid							
		1		A							

[Legend]

A: Number of idle cycle insertion A is selected.

B: Number of idle cycle insertion B is selected.

Invalid: No idle cycle is inserted for the corresponding condition.

Table 9.21 Number of Idle Cycle Insertions

Bit Settings				Number of Cycles
A		B		
IDLCA1	IDLCA0	IDLCB1	IDLCB0	
—	—	0	0	0
0	0	—	—	1
0	1	0	1	2
1	0	1	0	3
1	1	1	1	4

(1) Consecutive Reads in Different Areas

If consecutive reads in different areas occur while bit IDLS1 in IDLCR is set to 1, idle cycles specified by bits IDLCA1 and IDLCA0 when bit IDLSELn in IDLCR is cleared to 0, or bits IDLCB1 and IDLCB0 when bit IDLSELn is set to 1 are inserted at the start of the second read cycle (n = 0 to 7).

Figure 9.37 shows an example of the operation in this case. In this example, bus cycle A is a read cycle for ROM with a long output floating time, and bus cycle B is a read cycle for SRAM, each being located in a different area. In (a), an idle cycle is not inserted, and a conflict occurs in bus cycle B between the read data from ROM and that from SRAM. In (b), an idle cycle is inserted, and a data conflict is prevented.

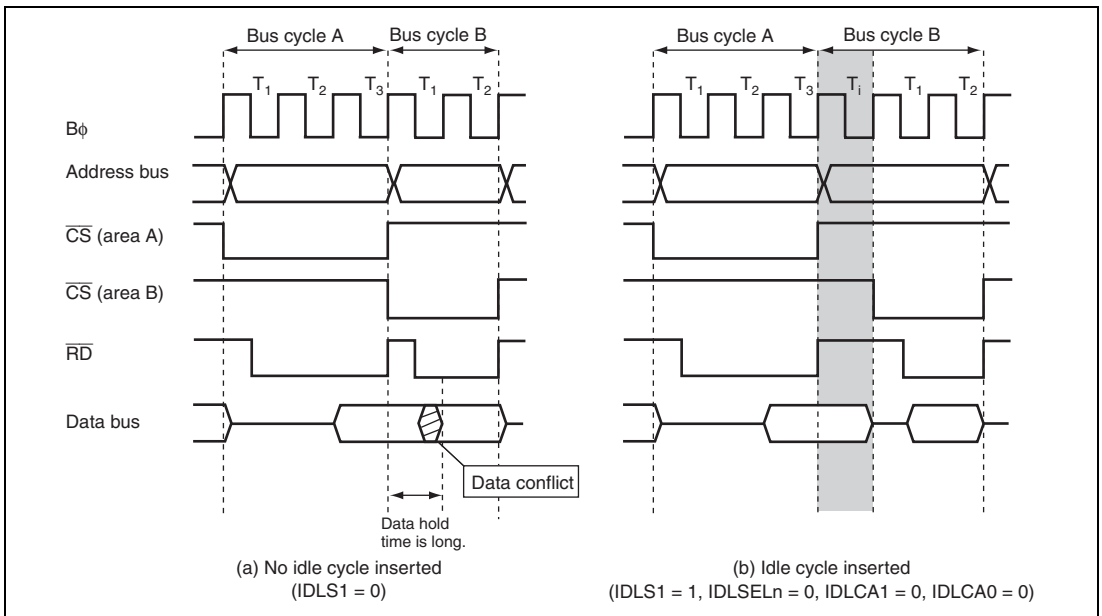

Figure 9.37 Example of Idle Cycle Operation (Consecutive Reads in Different Areas)

(2) Write after Read

If an external write occurs after an external read while bit IDLS0 in IDLCR is set to 1, idle cycles specified by bits IDLCA1 and IDLCA0 when bit IDLSELn in IDLCR is cleared to 0 when IDLSELn = 0, or bits IDLCB1 and IDLCB0 when IDLSELn is set to 1 are inserted at the start of the write cycle (n = 0 to 7).

Figure 9.38 shows an example of the operation in this case. In this example, bus cycle A is a read cycle for ROM with a long output floating time, and bus cycle B is a CPU write cycle. In (a), an idle cycle is not inserted, and a conflict occurs in bus cycle B between the read data from ROM and the CPU write data. In (b), an idle cycle is inserted, and a data conflict is prevented.

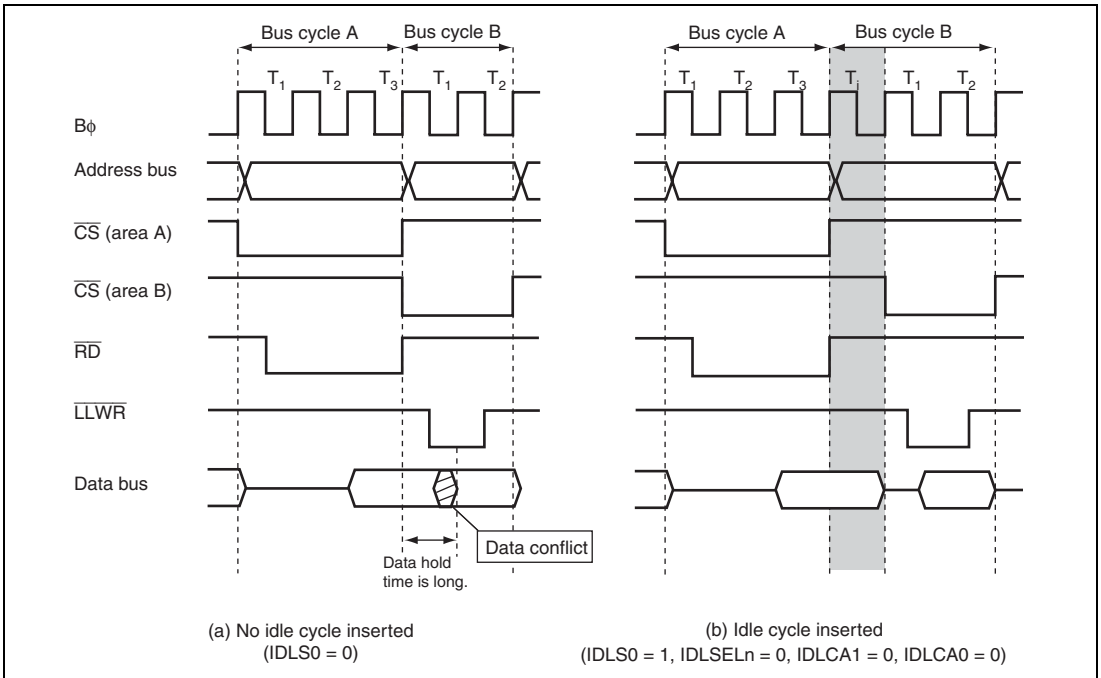

Figure 9.38 Example of Idle Cycle Operation (Write after Read)

(3) Read after Write

If an external read occurs after an external write while bit IDLS2 in IDLCR is set to 1, idle cycles specified by bits IDLCA1 and IDLCA0 are inserted at the start of the read cycle ($n = 0$ to 7).

Figure 9.39 shows an example of the operation in this case. In this example, bus cycle A is a CPU write cycle and bus cycle B is a read cycle from the SRAM. In (a), an idle cycle is not inserted, and a conflict occurs in bus cycle B between the CPU write data and read data from an SRAM device. In (b), an idle cycle is inserted, and a data conflict is prevented.

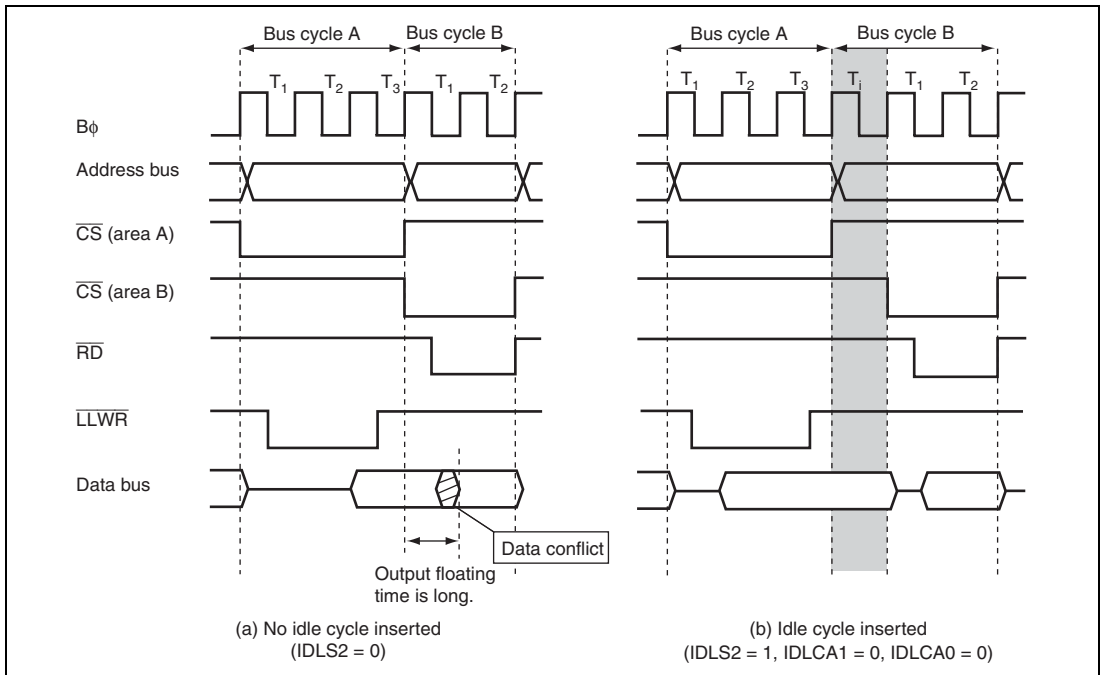

Figure 9.39 Example of Idle Cycle Operation (Read after Write)

(4) External Access after Single Address Transfer Write

If an external access occurs after a single address transfer write while bit IDLS3 in IDLCR is set to 1, idle cycles specified by bits IDLCA1 and IDLCA0 are inserted at the start of the external access ($n = 0$ to 7).

Figure 9.40 shows an example of the operation in this case. In this example, bus cycle A is a single address transfer (write cycle) and bus cycle B is a CPU write cycle. In (a), an idle cycle is not inserted, and a conflict occurs in bus cycle B between the external device write data and this LSI write data. In (b), an idle cycle is inserted, and a data conflict is prevented.

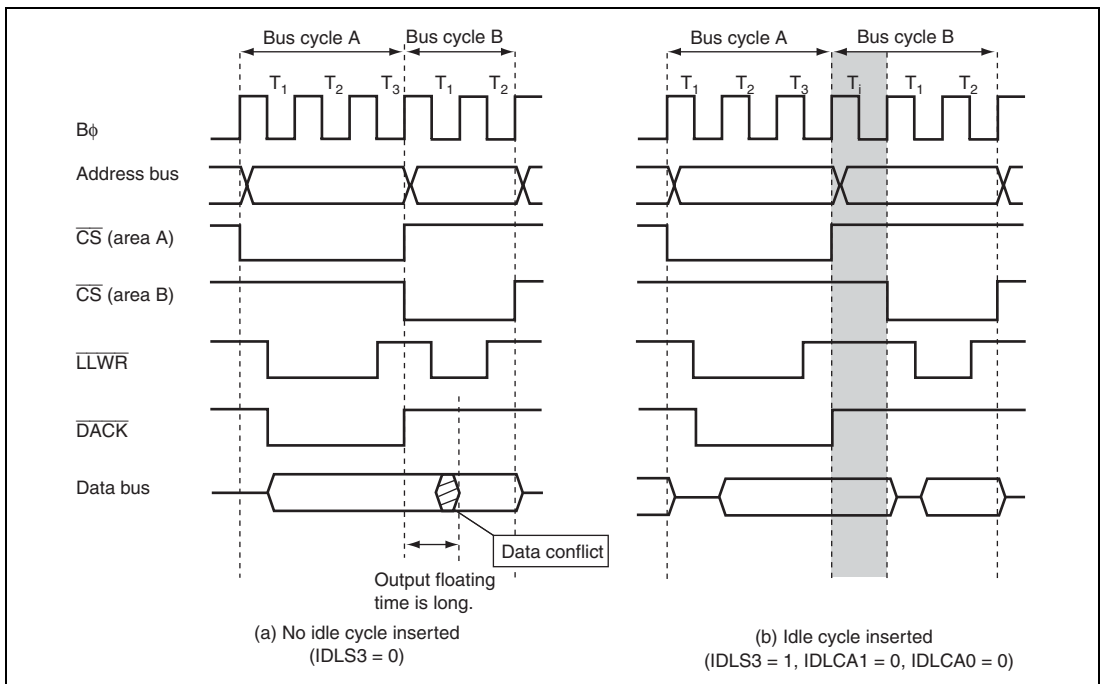

Figure 9.40 Example of Idle Cycle Operation (Write after Single Address Transfer Write)

(5) External NOP Cycles and Idle Cycles

A cycle in which an external space is not accessed due to internal operations is called an external NOP cycle. Even when an external NOP cycle occurs between consecutive external bus cycles, an idle cycle can be inserted. In this case, the number of external NOP cycles is included in the number of idle cycles to be inserted.

Figure 9.41 shows an example of external NOP and idle cycle insertion.

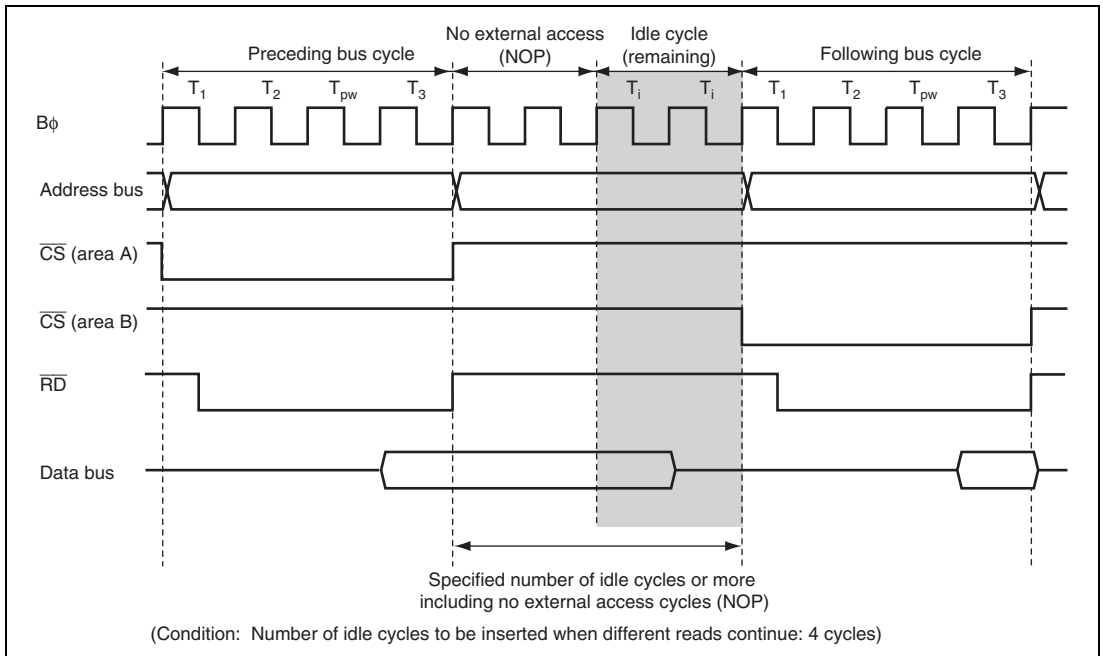

Figure 9.41 Idle Cycle Insertion Example

(6) Relationship between Chip Select (\overline{CS}) Signal and Read (\overline{RD}) Signal

Depending on the system's load conditions, the \overline{RD} signal may lag behind the \overline{CS} signal. An example is shown in figure 9.44. In this case, with the setting for no idle cycle insertion (a), there may be a period of overlap between the \overline{RD} signal in bus cycle A and the \overline{CS} signal in bus cycle B. Setting idle cycle insertion, as in (b), however, will prevent any overlap between the \overline{RD} and \overline{CS} signals. In the initial state after reset release, idle cycle indicated in (b) is set.

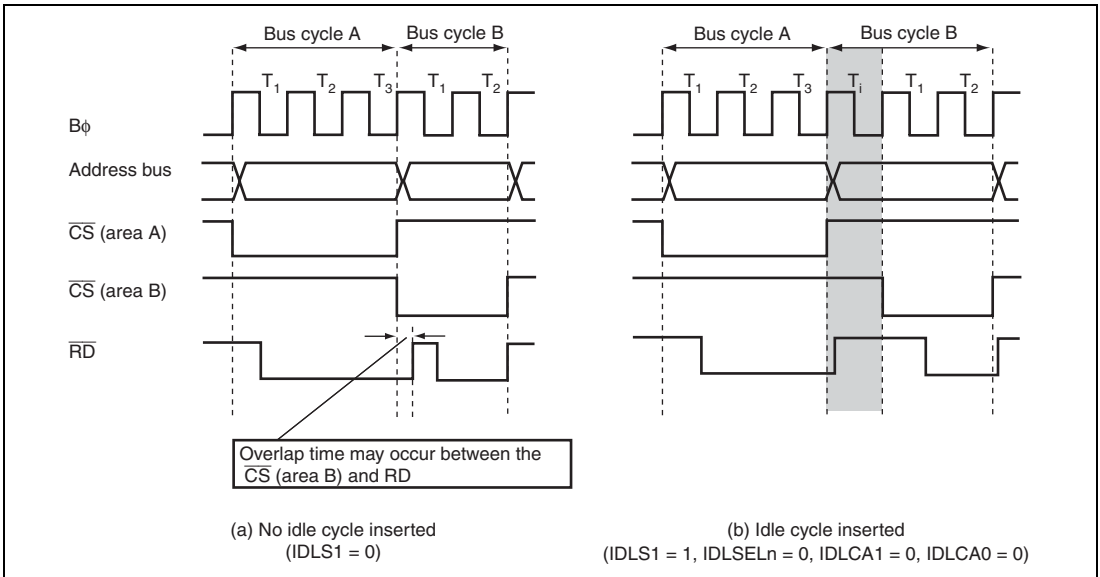

Figure 9.42 Relationship between Chip Select (\overline{CS}) and Read (\overline{RD})

Table 9.22 Idle Cycles in Mixed Accesses to Normal Space

Previous Access	Next Access	IDLS				IDLSEL	IDLCA		IDLCB		Idle Cycle
		3	2	1	0	7 to 0	1	0	1	0	
Normal space read	Normal space read	—	—	0	—	—	—	—	—	—	Disabled
		—	—	1	—	0	0	0	—	—	1 cycle inserted
							0	1			2 cycles inserted
							1	0			3 cycles inserted
							1	1			4 cycles inserted
						1	—	—	0	0	0 cycle inserted
									0	1	2 cycle inserted
									1	0	3 cycles inserted
									1	1	4 cycles inserted
Normal space read	Normal space write	—	—	—	0	—	—	—	—	—	Disabled
		—	—	—	1	0	0	0	—	—	1 cycle inserted
							0	1			2 cycles inserted
							1	0			3 cycles inserted
							1	1			4 cycles inserted
						1	—	—	0	0	0 cycle inserted
									0	1	2 cycle inserted
									1	0	3 cycles inserted
									1	1	4 cycles inserted
Normal space write	Normal space read	—	0	—	—	—	—	—	—	—	Disabled
		—	1	—	—	—	0	0	—	—	1 cycle inserted
							0	1			2 cycles inserted
							1	0			3 cycles inserted
							1	1			4 cycles inserted
Single address transfer write	Normal space read	0	—	—	—	—	—	—	—	—	Disabled
		1	—	—	—	—	0	0	—	—	1 cycle inserted
							0	1			2 cycles inserted
							1	0			3 cycles inserted
							1	1			4 cycles inserted

9.10.2 Pin States in Idle Cycle

Table 9.23 shows the pin states in an idle cycle.

Table 9.23 Pin States in Idle Cycle

Pins	Pin State
A20 to A0	Contents of following bus cycle
D15 to D0	High impedance
\overline{CS}_n (n = 7 to 0)	High
\overline{AS}	High
\overline{RD}	High
\overline{BS}	High
$\overline{RD}/\overline{WR}$	High
\overline{AH}	low
\overline{LHWR} , \overline{LLWR}	High
\overline{DACK}_n (n = 3 to 0)	High

9.11 Bus Release

This LSI can release the external bus in response to a bus request from an external device. In the external bus released state, internal bus masters continue to operate as long as there is no external access.

In addition, in the external bus released state, the $\overline{\text{BREQO}}$ signal can be driven low to output a bus request externally.

9.11.1 Operation

In external extended mode, when the BRLE bit in BCR1 is set to 1 and the ICR bits for the corresponding pin are set to 1, the bus can be released to the external. Driving the $\overline{\text{BREQ}}$ pin low issues an external bus request to this LSI. When the $\overline{\text{BREQ}}$ pin is sampled, at the prescribed timing, the $\overline{\text{BACK}}$ pin is driven low, and the address bus, data bus, and bus control signals are placed in the high-impedance state, establishing the external bus released state. For details on DDR and ICR, see section 12, I/O Ports.

In the external bus released state, the CPU, DTC, and DMAC can access the internal space using the internal bus. When the CPU, DTC, or DMAC attempts to access the external address space, it temporarily defers initiation of the bus cycle, and waits for the bus request from the external bus master to be canceled.

If the BREQOE bit in BCR1 is set to 1, the $\overline{\text{BREQO}}$ pin can be driven low when any of the following requests are issued, to request cancellation of the bus request externally.

- When the CPU, DTC, or DMAC attempts to access the external address space
- When a SLEEP instruction is executed to place the chip in software standby mode or all-module-clock-stop mode
- When SCKCR is written to for setting the clock frequency

If an external bus release request and external access occur simultaneously, the priority is as follows:

(High) External bus release > External access by CPU, DTC, or DMAC (Low)

9.11.2 Pin States in External Bus Released State

Table 9.24 shows pin states in the external bus released state.

Table 9.24 Pin States in Bus Released State

Pins	Pin State
A20 to A0	High impedance
D15 to D0	High impedance
\overline{BS}	High impedance
\overline{CSn} (n = 7 to 0)	High impedance
\overline{AS}	High impedance
\overline{AH}	High impedance
$\overline{RD}/\overline{WR}$	High impedance
\overline{RD}	High impedance
\overline{LUB} , \overline{LLB}	High impedance
\overline{LHWR} , \overline{LLWR}	High impedance
\overline{DACKn} (n = 3 to 0)	High level

9.11.3 Transition Timing

Figure 9.43 shows the timing for transition to the bus released state.

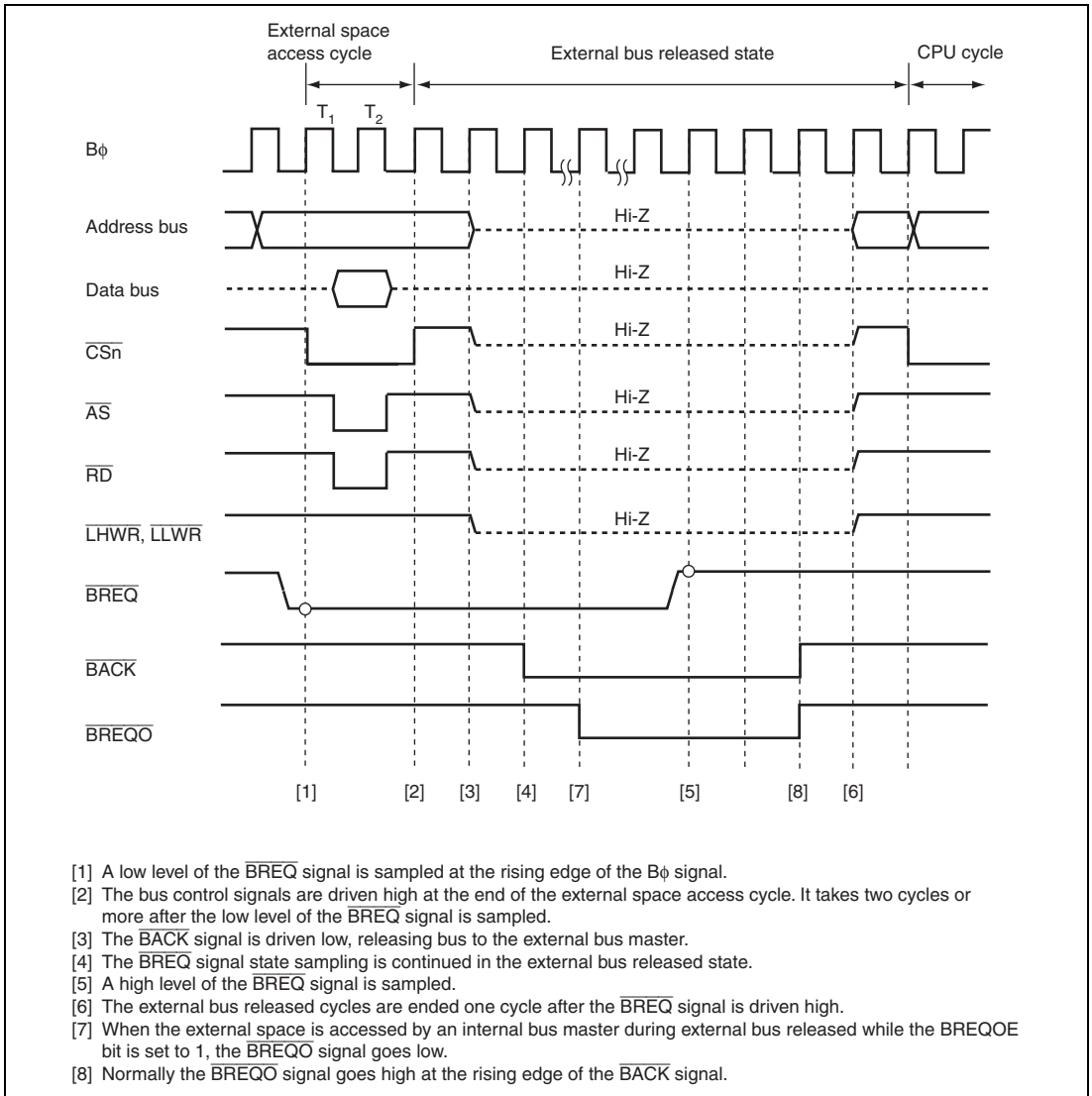

Figure 9.43 Bus Released State Transition Timing

9.12 Internal Bus

9.12.1 Access to Internal Address Space

The internal address spaces of this LSI are the on-chip ROM space, on-chip RAM space, and register space for the on-chip peripheral modules. The number of cycles necessary for access differs according to the space.

Table 9.25 shows the number of access cycles for each on-chip memory space.

Table 9.25 Number of Access Cycles for On-Chip Memory Spaces

Access Space	Access	Number of Access Cycles
On-chip ROM space	Read	One $l\phi$ cycle
	Write	Three $l\phi$ cycles
On-chip RAM space	Read	One $l\phi$ cycle
	Write	One $l\phi$ cycle

In access to the registers for on-chip peripheral modules, the number of access cycles differs according to the register to be accessed. When the dividing ratio of the operating clock of a bus master and that of a peripheral module is 1 : n, synchronization cycles using a clock divided by 0 to n-1 are inserted for register access in the same way as for external bus clock division.

Table 9.26 lists the number of access cycles for registers of on-chip peripheral modules.

Table 9.26 Number of Access Cycles for Registers of On-Chip Peripheral Modules

Module to be Accessed	Number of Cycles		
	Read	Write	Write Data Buffer Function
DMAC registers	Two $l\phi$	Two $l\phi$	Disabled
MCU operating mode, clock pulse generator, power-down control registers, interrupt controller, bus controller, and DTC registers	Two $l\phi$	Three $l\phi$	Disabled
I/O port registers of PFCR and WDT	Two $P\phi$	Three $P\phi$	Disabled
I/O port registers other than PFCR, PPG0, TPU, TMR0, TMR1, SCI0 to SCI4, IIC2_0, IIC2_1, D/A, and A/D_0 registers	Two $P\phi$	Two $P\phi$	Enabled
TMR2, TMR3, SCI5, SCI6, A/D_1, and PPG1 registers	Three $P\phi$	Three $P\phi$	Enabled

9.13 Write Data Buffer Function

9.13.1 Write Data Buffer Function for External Data Bus

This LSI has a write data buffer function for the external data bus. Using the write data buffer function enables internal accesses in parallel with external writes or DMAC single address transfers. The write data buffer function is made available by setting the WDBE bit to 1 in BCR1.

Figure 9.44 shows an example of the timing when the write data buffer function is used. When this function is used, if an external address space write or a DMAC single address transfer continues for two cycles or longer, and there is an internal access next, an external write only is executed in the first two cycles. However, from the next cycle onward, internal accesses (on-chip memory or internal I/O register read/write) and the external address space write rather than waiting until it ends are executed in parallel.

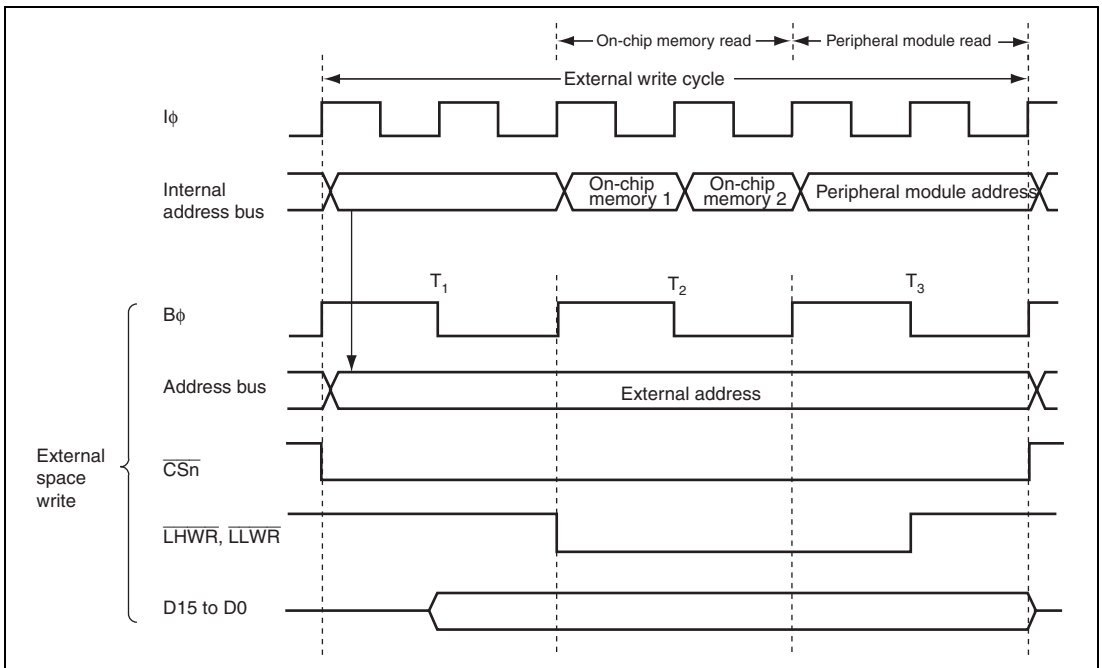

Figure 9.44 Example of Timing when Write Data Buffer Function is Used

9.13.2 Write Data Buffer Function for Peripheral Modules

This LSI has a write data buffer function for the peripheral module access. Using the write data buffer function enables peripheral module writes and on-chip memory or external access to be executed in parallel. The write data buffer function is made available by setting the PWDBE bit in BCR2 to 1. For details on the on-chip peripheral module registers, see table 9.26, Number of Access Cycles for Registers of On-Chip Peripheral Modules in section 9.12, Internal Bus.

Figure 9.45 shows an example of the timing when the write data buffer function is used. When this function is used, if an internal I/O register write continues for two cycles or longer and then there is an on-chip RAM, an on-chip ROM, or an external access, internal I/O register write only is performed in the first two cycles. However, from the next cycle onward an internal memory or an external access and internal I/O register write are executed in parallel rather than waiting until it ends.

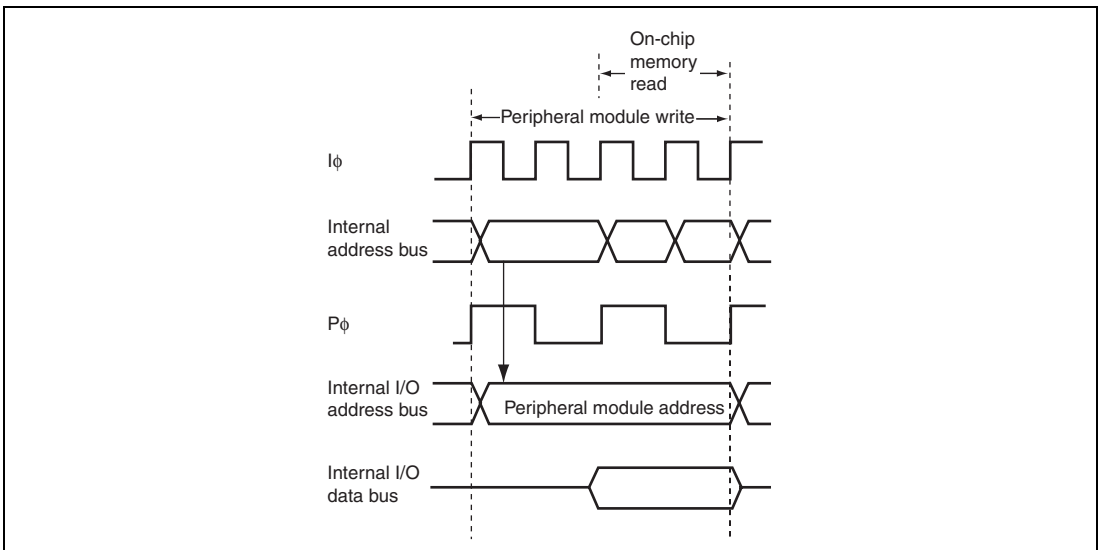

Figure 9.45 Example of Timing when Peripheral Module Write Data Buffer Function is Used

9.14 Bus Arbitration

This LSI has bus arbiters that arbitrate bus mastership operations (bus arbitration). This LSI incorporates internal access and external access bus arbiters that can be used and controlled independently. The internal bus arbiter handles the CPU, DTC, and DMAC accesses. The external bus arbiter handles the external access by the CPU, DTC, and DMAC and external bus release request (external bus master).

The bus arbiters determine priorities at the prescribed timing, and permit use of the bus by means of the bus request acknowledge signal.

9.14.1 Operation

The bus arbiter detects the bus masters' bus request signals, and if the bus is requested, sends a bus request acknowledge signal to the bus master. If there are bus requests from more than one bus master, the bus request acknowledge signal is sent to the one with the highest priority. When a bus master receives the bus request acknowledge signal, it takes possession of the bus until that signal is canceled.

The priority of the internal bus arbitration:

(High) DMAC > DTC > CPU (Low)

The priority of the external bus arbitration:

(High) External bus release request > External access by the CPU, DTC, and DMAC (Low)

If the DMAC or DTC accesses continue, the CPU can be given priority over the DMAC or DTC to execute the bus cycles alternatively between them by setting the IBCCS bit in BCR2. In this case, the priority between the DMAC and DTC does not change.

An internal bus access by the CPU, DTC, or DMAC and an external bus access by an external bus release request can be executed in parallel.

9.14.2 Bus Transfer Timing

Even if a bus request is received from a bus master with a higher priority over that of the bus master that has taken control of the bus and is currently operating, the bus is not necessarily transferred immediately. There are specific timings at which each bus master can release the bus.

(1) CPU

The CPU is the lowest-priority bus master, and if a bus request is received from the DTC or DMAC, the bus arbiter transfers the bus to the bus master that issued the request.

The timing for transfer of the bus is at the end of the bus cycle. In sleep mode, the bus is transferred synchronously with the clock.

Note, however, that the bus cannot be transferred in the following cases.

- The word or longword access is performed in some divisions.
- Stack handling is performed in multiple bus cycles.
- Transfer data read or write by memory transfer instructions, block transfer instructions, or TAS instruction.

(In the block transfer instructions, the bus can be transferred in the write cycle and the following transfer data read cycle.)

- From the target read to write in the bit manipulation instructions or memory operation instructions.

(In an instruction that performs no write operation according to the instruction condition, up to a cycle corresponding the write cycle)

(2) DTC

The DTC sends the internal bus arbiter a request for the bus when an activation request is generated. When the DTC accesses an external bus space, the DTC first takes control of the bus from the internal bus arbiter and then requests a bus to the external bus arbiter.

Once the DTC takes control of the bus, the DTC continues the transfer processing cycles. If a bus master whose priority is higher than the DTC requests the bus, the DTC transfers the bus to the higher priority bus master. If the IBCCS bit in BCR2 is set to 1, the DTC transfers the bus to the CPU.

Note, however, that the bus cannot be transferred in the following cases.

- During transfer information read
- During the first data transfer
- During transfer information write back

The DTC releases the bus when the consecutive transfer cycles completed.

(3) DMAC

The DMAC sends the internal bus arbiter a request for the bus when an activation request is generated. When the DMAC accesses an external bus space, the DMAC first takes control of the bus from the internal bus arbiter and then requests a bus to the external bus arbiter.

After the DMAC takes control of the bus, it may continue the transfer processing cycles or release the bus at the end of every bus cycle depending on the conditions.

The DMAC continues transfers without releasing the bus in the following case:

- Between the read cycle in the dual-address mode and the write cycle corresponding to the read cycle

If no bus master of a higher priority than the DMAC requests the bus and the IBCCS bit in BCR2 is cleared to 0, the DMAC continues transfers without releasing the bus in the following cases:

- During 1-block transfers in the block transfer mode
- During transfers in the burst mode

In other cases, the DMAC transfers the bus at the end of the bus cycle.

(4) External Bus Release

When the $\overline{\text{BREQ}}$ pin goes low and an external bus release request is issued while the BRLE bit in BCR1 is set to 1 with the corresponding ICR bit set to 1, a bus request is sent to the bus arbiter.

External bus release can be performed on completion of an external bus cycle.

9.15 Bus Controller Operation in Reset

In a reset, this LSI, including the bus controller, enters the reset state immediately, and any executing bus cycle is aborted.

9.16 Usage Notes

(1) Setting Registers

The BSC registers must be specified before accessing the external address space. In on-chip ROM disabled mode, the BSC registers must be specified before accessing the external address space for other than an instruction fetch access.

(2) External Bus Release Function and All-Module-Clock-Stop Mode

In this LSI, if the ACSE bit in MSTPCRA is set to 1, and then a SLEEP instruction is executed with the setting for all peripheral module clocks to be stopped (MSTPCRA and MSTPCRB = H'FFFFFFF) or for operation of the 8-bit timer module alone (MSTPCRA and MSTPCRB = H'[F to C]FFFFFF), and a transition is made to the sleep state, the all-module-clock-stop mode is entered in which the clock is also stopped for the bus controller and I/O ports. For details, see section 25, Power-Down Modes.

In this state, the external bus release function is halted. To use the external bus release function in sleep mode, the ACSE bit in MSTPCR must be cleared to 0. Conversely, if a SLEEP instruction to place the chip in all-module-clock-stop mode is executed in the external bus released state, the transition to all-module-clock-stop mode is deferred and performed until after the bus is recovered.

(3) External Bus Release Function and Software Standby

In this LSI, internal bus master operation does not stop even while the bus is released, as long as the program is running in on-chip ROM, etc., and no external access occurs. If a SLEEP instruction to place the chip in software standby mode is executed while the external bus is released, the transition to software standby mode is deferred and performed after the bus is recovered.

Also, since clock oscillation halts in software standby mode, if the $\overline{\text{BREQ}}$ signal goes low in this mode, indicating an external bus release request, the request cannot be answered until the chip has recovered from the software standby mode.

Note that the $\overline{\text{BACK}}$ and $\overline{\text{BREQO}}$ pins are both in the high-impedance state in software standby mode.

(4) $\overline{\text{BREQO}}$ Output Timing

When the BREQOE bit is set to 1 and the $\overline{\text{BREQO}}$ signal is output, both the $\overline{\text{BREQO}}$ and $\overline{\text{BACK}}$ signals may go low simultaneously.

This will occur if the next external access request occurs while internal bus arbitration is in progress after the chip samples a low level of the $\overline{\text{BREQ}}$ signal.

Section 10 DMA Controller (DMAC)

This LSI includes a 4-channel DMA controller (DMAC).

10.1 Features

- Maximum of 4-G byte address space can be accessed
- Byte, word, or longword can be set as data transfer unit
- Maximum of 4-G bytes (4,294,967,295 bytes) can be set as total transfer size
Supports free-running mode in which total transfer size setting is not needed
- DMAC activation methods are auto-request, on-chip module interrupt, and external request.
 - Auto request: CPU activates (cycle stealing or burst access can be selected)
 - On-chip module interrupt: Interrupt requests from on-chip peripheral modules can be selected as an activation source
 - External request: Low level or falling edge detection of the $\overline{\text{DREQ}}$ signal can be selected. External request is available for all four channels.
- Dual or single address mode can be selected as address mode
 - Dual address mode: Both source and destination are specified by addresses
 - Single address mode: Either source or destination is specified by the $\overline{\text{DACK}}$ signal and the other is specified by address
- Normal, repeat, or block transfer can be selected as transfer mode
 - Normal transfer mode: One byte, one word, or one longword data is transferred at a single transfer request
 - Repeat transfer mode: One byte, one word, or one longword data is transferred at a single transfer request
Repeat size of data is transferred and then a transfer address returns to the transfer start address
Up to 65536 transfers (65,536 bytes/words/longwords) can be set as repeat size
 - Block transfer mode: One block data is transferred at a single transfer request
Up to 65,536 bytes/words/longwords can be set as block size

- Extended repeat area function which repeats the addressees within a specified area using the transfer address with the fixed upper bits (ring buffer transfer can be performed, as an example) is available
One bit (two bytes) to 27 bits (128 Mbytes) for transfer source and destination can be set as extended repeat areas
- Address update can be selected from fixed address, offset addition, and increment or decrement by 1, 2, or 4
Address update by offset addition enables to transfer data at addresses which are not placed continuously
- Word or longword data can be transferred to an address which is not aligned with the respective boundary
Data is divided according to its address (byte or word) when it is transferred
- Two types of interrupts can be requested to the CPU
A transfer end interrupt is generated after the number of data specified by the transfer counter is transferred. A transfer escape end interrupt is generated when the remaining total transfer size is less than the transfer data size at a single transfer request, when the repeat size of data transfer is completed, or when the extended repeat area overflows.
- Module stop state can be set.

A block diagram of the DMAC is shown in Figure 10.1.

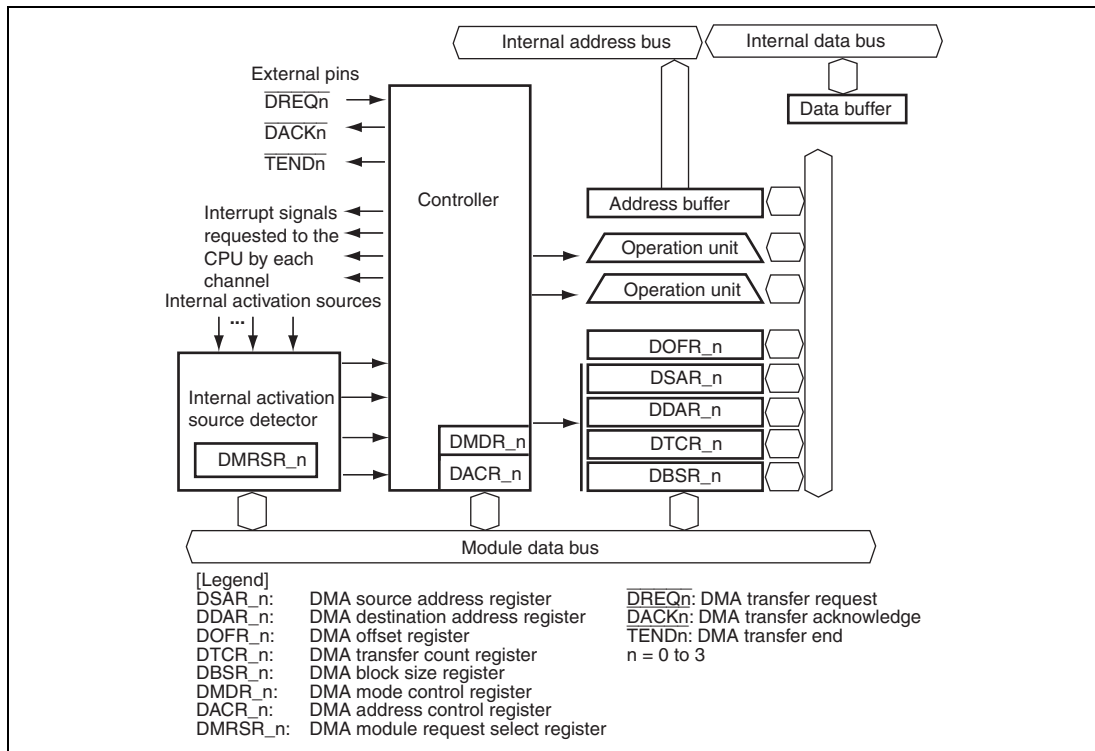

Figure 10.1 Block Diagram of DMAC

10.2 Input/Output Pins

Table 10.1 shows the pin configuration of the DMAC.

Table 10.1 Pin Configuration

Channel	Pin Name	Abbr.	I/O	Function
0	DMA transfer request 0	$\overline{\text{DREQ0}}$	Input	Channel 0 external request
	DMA transfer acknowledge 0	$\overline{\text{DACK0}}$	Output	Channel 0 single address transfer acknowledge
	DMA transfer end 0	$\overline{\text{TEND0}}$	Output	Channel 0 transfer end
1	DMA transfer request 1	$\overline{\text{DREQ1}}$	Input	Channel 1 external request
	DMA transfer acknowledge 1	$\overline{\text{DACK1}}$	Output	Channel 1 single address transfer acknowledge
	DMA transfer end 1	$\overline{\text{TEND1}}$	Output	Channel 1 transfer end
2	DMA transfer request 2	$\overline{\text{DREQ2}}$	Input	Channel 2 external request
	DMA transfer acknowledge 2	$\overline{\text{DACK2}}$	Output	Channel 2 single address transfer acknowledge
	DMA transfer end 2	$\overline{\text{TEND2}}$	Output	Channel 2 transfer end
3	DMA transfer request 3	$\overline{\text{DREQ3}}$	Input	Channel 3 external request
	DMA transfer acknowledge 3	$\overline{\text{DACK3}}$	Output	Channel 3 single address transfer acknowledge
	DMA transfer end 3	$\overline{\text{TEND3}}$	Output	Channel 3 transfer end

10.3 Register Descriptions

The DMAC has the following registers.

Channel 0:

- DMA source address register_0 (DSAR_0)
- DMA destination address register_0 (DDAR_0)
- DMA offset register_0 (DOFR_0)
- DMA transfer count register_0 (DTCR_0)
- DMA block size register_0 (DBSR_0)
- DMA mode control register_0 (DMDR_0)
- DMA address control register_0 (DACR_0)
- DMA module request select register_0 (DMRSR_0)

Channel 1:

- DMA source address register_1 (DSAR_1)
- DMA destination address register_1 (DDAR_1)
- DMA offset register_1 (DOFR_1)
- DMA transfer count register_1 (DTCR_1)
- DMA block size register_1 (DBSR_1)
- DMA mode control register_1 (DMDR_1)
- DMA address control register_1 (DACR_1)
- DMA module request select register_1 (DMRSR_1)

Channel 2:

- DMA source address register_2 (DSAR_2)
- DMA destination address register_2 (DDAR_2)
- DMA offset register_2 (DOFR_2)
- DMA transfer count register_2 (DTCR_2)
- DMA block size register_2 (DBSR_2)
- DMA mode control register_2 (DMDR_2)
- DMA address control register_2 (DACR_2)
- DMA module request select register_2 (DMRSR_2)

Channel 3:

- DMA source address register_3 (DSAR_3)
- DMA destination address register_3 (DDAR_3)
- DMA offset register_3 (DOFR_3)
- DMA transfer count register_3 (DTCR_3)
- DMA block size register_3 (DBSR_3)
- DMA mode control register_3 (DMDR_3)
- DMA address control register_3 (DACR_3)
- DMA module request select register_3 (DMRSR_3)

10.3.1 DMA Source Address Register (DSAR)

DSAR is a 32-bit readable/writable register that specifies the transfer source address. DSAR updates the transfer source address every time data is transferred. When DDAR is specified as the destination address (the DIRS bit in DACR is 1) in single address mode, DSAR is ignored.

Although DSAR can always be read from by the CPU, it must be read from in longwords and must not be written to while data for the channel is being transferred.

Bit	31	30	29	28	27	26	25	24
Bit Name								
Initial Value	0	0	0	0	0	0	0	0
R/W	R/W	R/W	R/W	R/W	R/W	R/W	R/W	R/W
Bit	23	22	21	20	19	18	17	16
Bit Name								
Initial Value	0	0	0	0	0	0	0	0
R/W	R/W	R/W	R/W	R/W	R/W	R/W	R/W	R/W
Bit	15	14	13	12	11	10	9	8
Bit Name								
Initial Value	0	0	0	0	0	0	0	0
R/W	R/W	R/W	R/W	R/W	R/W	R/W	R/W	R/W
Bit	7	6	5	4	3	2	1	0
Bit Name								
Initial Value	0	0	0	0	0	0	0	0
R/W	R/W	R/W	R/W	R/W	R/W	R/W	R/W	R/W

10.3.2 DMA Destination Address Register (DDAR)

DDAR is a 32-bit readable/writable register that specifies the transfer destination address. DDAR updates the transfer destination address every time data is transferred. When DSAR is specified as the source address (the DIRS bit in DACR is 0) in single address mode, DDAR is ignored.

Although DDAR can always be read from by the CPU, it must be read from in longwords and must not be written to while data for the channel is being transferred.

Bit	31	30	29	28	27	26	25	24
Bit Name								
Initial Value	0	0	0	0	0	0	0	0
R/W	R/W	R/W	R/W	R/W	R/W	R/W	R/W	R/W
Bit	23	22	21	20	19	18	17	16
Bit Name								
Initial Value	0	0	0	0	0	0	0	0
R/W	R/W	R/W	R/W	R/W	R/W	R/W	R/W	R/W
Bit	15	14	13	12	11	10	9	8
Bit Name								
Initial Value	0	0	0	0	0	0	0	0
R/W	R/W	R/W	R/W	R/W	R/W	R/W	R/W	R/W
Bit	7	6	5	4	3	2	1	0
Bit Name								
Initial Value	0	0	0	0	0	0	0	0
R/W	R/W	R/W	R/W	R/W	R/W	R/W	R/W	R/W

10.3.3 DMA Offset Register (DOFR)

DOFR is a 32-bit readable/writable register that specifies the offset to update the source and destination addresses. Although different values are specified for individual channels, the same values must be specified for the source and destination sides of a single channel.

Bit	31	30	29	28	27	26	25	24
Bit Name								
Initial Value	0	0	0	0	0	0	0	0
R/W	R/W	R/W	R/W	R/W	R/W	R/W	R/W	R/W
Bit	23	22	21	20	19	18	17	16
Bit Name								
Initial Value	0	0	0	0	0	0	0	0
R/W	R/W	R/W	R/W	R/W	R/W	R/W	R/W	R/W
Bit	15	14	13	12	11	10	9	8
Bit Name								
Initial Value	0	0	0	0	0	0	0	0
R/W	R/W	R/W	R/W	R/W	R/W	R/W	R/W	R/W
Bit	7	6	5	4	3	2	1	0
Bit Name								
Initial Value	0	0	0	0	0	0	0	0
R/W	R/W	R/W	R/W	R/W	R/W	R/W	R/W	R/W

10.3.4 DMA Transfer Count Register (DTCR)

DTCR is a 32-bit readable/writable register that specifies the size of data to be transferred (total transfer size).

To transfer 1-byte data in total, set H'00000001 in DTCR. When H'00000000 is set in this register, it means that the total transfer size is not specified and data is transferred with the transfer counter stopped (free running mode). When H'FFFFFFFF is set, the total transfer size is 4 Gbytes (4,294,967,295), which is the maximum size. While data is being transferred, this register indicates the remaining transfer size. The value corresponding to its data access size is subtracted every time data is transferred (byte: -1, word: -2, and longword: -4).

Although DTCR can always be read from by the CPU, it must be read from in longwords and must not be written to while data for the channel is being transferred.

Bit	31	30	29	28	27	26	25	24
Bit Name								
Initial Value	0	0	0	0	0	0	0	0
R/W	R/W	R/W	R/W	R/W	R/W	R/W	R/W	R/W
Bit	23	22	21	20	19	18	17	16
Bit Name								
Initial Value	0	0	0	0	0	0	0	0
R/W	R/W	R/W	R/W	R/W	R/W	R/W	R/W	R/W
Bit	15	14	13	12	11	10	9	8
Bit Name								
Initial Value	0	0	0	0	0	0	0	0
R/W	R/W	R/W	R/W	R/W	R/W	R/W	R/W	R/W
Bit	7	6	5	4	3	2	1	0
Bit Name								
Initial Value	0	0	0	0	0	0	0	0
R/W	R/W	R/W	R/W	R/W	R/W	R/W	R/W	R/W

10.3.5 DMA Block Size Register (DBSR)

DBSR specifies the repeat size or block size. DBSR is enabled in repeat transfer mode and block transfer mode and is disabled in normal transfer mode.

Bit	31	30	29	28	27	26	25	24
Bit Name	BKSZH31	BKSZH30	BKSZH29	BKSZH28	BKSZH27	BKSZH26	BKSZH25	BKSZH24
Initial Value	0	0	0	0	0	0	0	0
R/W	R/W	R/W	R/W	R/W	R/W	R/W	R/W	R/W
Bit	23	22	21	20	19	18	17	16
Bit Name	BKSZH23	BKSZH22	BKSZH21	BKSZH20	BKSZH19	BKSZH18	BKSZH17	BKSZH16
Initial Value	0	0	0	0	0	0	0	0
R/W	R/W	R/W	R/W	R/W	R/W	R/W	R/W	R/W
Bit	15	14	13	12	11	10	9	8
Bit Name	BKSZ15	BKSZ14	BKSZ13	BKSZ12	BKSZ11	BKSZ10	BKSZ9	BKSZ8
Initial Value	0	0	0	0	0	0	0	0
R/W	R/W	R/W	R/W	R/W	R/W	R/W	R/W	R/W
Bit	7	6	5	4	3	2	1	0
Bit Name	BKSZ7	BKSZ6	BKSZ5	BKSZ4	BKSZ3	BKSZ2	BKSZ1	BKSZ0
Initial Value	0	0	0	0	0	0	0	0
R/W	R/W	R/W	R/W	R/W	R/W	R/W	R/W	R/W

Bit	Bit Name	Initial Value	R/W	Description
31 to 16	BKSZH31 to BKSZH16	All 0	R/W	Specify the repeat size or block size. When H'0001 is set, the repeat or block size is one byte, one word, or one longword. When H'0000 is set, it means the maximum value (refer to Table 10.1). While the DMA is in operation, the setting is fixed.
15 to 0	BKSZ15 to BKSZ0	All 0	R/W	Indicate the remaining repeat or block size while the DMA is in operation. The value is decremented by 1 every time data is transferred. When the remaining size becomes 0, the value of the BKSZH bits is loaded. Set the same value as the BKSZH bits.

Table 10.2 Data Access Size, Valid Bits, and Settable Size

Mode	Data Access Size	BKSZH Valid Bits	BKSZ Valid Bits	Settable Size (Byte)
Repeat transfer and block transfer	Byte	31 to 16	15 to 0	1 to 65,536
	Word			2 to 131,072
	Longword			4 to 262,144

10.3.6 DMA Mode Control Register (DMDR)

DMDR controls the DMAC operation.

- DMDR_0

Bit	31	30	29	28	27	26	25	24
Bit Name	DTE	DACKE	TENDE	—	DREQS	NRD	—	—
Initial Value	0	0	0	0	0	0	0	0
R/W	R/W	R/W	R/W	R/W	R/W	R/W	R	R
Bit	23	22	21	20	19	18	17	16
Bit Name	ACT	—	—	—	ERRF	—	ESIF	DTIF
Initial Value	0	0	0	0	0	0	0	0
R/W	R	R	R	R	R/(W)*	R	R/(W)*	R/(W)*
Bit	15	14	13	12	11	10	9	8
Bit Name	DTSZ1	DTSZ0	MDS1	MDS0	TSEIE	—	ESIE	DTIE
Initial Value	0	0	0	0	0	0	0	0
R/W	R/W	R/W	R/W	R/W	R/W	R	R/W	R/W
Bit	7	6	5	4	3	2	1	0
Bit Name	DTF1	DTF0	DTA	—	—	DMAP2	DMAP1	DMAP0
Initial Value	0	0	0	0	0	0	0	0
R/W	R/W	R/W	R/W	R	R	R/W	R/W	R/W

Note: * Only 0 can be written to this bit after having been read as 1, to clear the flag.

- DMDR_1 to DMDR_3

Bit	31	30	29	28	27	26	25	24
Bit Name	DTE	DACKE	TENDE	—	DREQS	NRD	—	—
Initial Value	0	0	0	0	0	0	0	0
R/W	R/W	R/W	R/W	R/W	R/W	R/W	R	R
Bit	23	22	21	20	19	18	17	16
Bit Name	ACT	—	—	—	—	—	ESIF	DTIF
Initial Value	0	0	0	0	0	0	0	0
R/W	R	R	R	R	R	R	R/(W)*	R/(W)*
Bit	15	14	13	12	11	10	9	8
Bit Name	DTSZ1	DTSZ0	MDS1	MDS0	TSEIE	—	ESIE	DTIE
Initial Value	0	0	0	0	0	0	0	0
R/W	R/W	R/W	R/W	R/W	R/W	R	R/W	R/W
Bit	7	6	5	4	3	2	1	0
Bit Name	DTF1	DTF0	DTA	—	—	DMAP2	DMAP1	DMAPO
Initial Value	0	0	0	0	0	0	0	0
R/W	R/W	R/W	R/W	R	R	R/W	R/W	R/W

Note: * Only 0 can be written to this bit after having been read as 1, to clear the flag.

Bit	Bit Name	Initial Value	R/W	Description
31	DTE	0	R/W	<p>Data Transfer Enable</p> <p>Enables/disables a data transfer for the corresponding channel. When this bit is set to 1, it indicates that the DMAC is in operation.</p> <p>Setting this bit to 1 starts a transfer when the auto-request is selected. When the on-chip module interrupt or external request is selected, a transfer request after setting this bit to 1 starts the transfer. While data is being transferred, clearing this bit to 0 stops the transfer.</p> <p>In block transfer mode, if writing 0 to this bit while data is being transferred, this bit is cleared to 0 after the current 1-block size data transfer.</p> <p>If an event which stops (sustains) a transfer occurs externally, this bit is automatically cleared to 0 to stop the transfer.</p> <p>Operating modes and transfer methods must not be changed while this bit is set to 1.</p> <p>0: Disables a data transfer 1: Enables a data transfer (DMA is in operation)</p> <p>[Clearing conditions]</p> <ul style="list-style-type: none"> • When the specified total transfer size of transfers is completed • When a transfer is stopped by an overflow interrupt by a repeat size end • When a transfer is stopped by an overflow interrupt by an extended repeat size end • When a transfer is stopped by a transfer size error interrupt • When clearing this bit to 0 to stop a transfer <p>In block transfer mode, this bit changes after the current block transfer.</p> <ul style="list-style-type: none"> • When an address error or an NMI interrupt is requested • In the reset state or hardware standby mode

Bit	Bit Name	Initial Value	R/W	Description
30	DACKE	0	R/W	<p>$\overline{\text{DACK}}$ Signal Output Enable</p> <p>Enables/disables the $\overline{\text{DACK}}$ signal output in single address mode. This bit is ignored in dual address mode.</p> <p>0: Disables $\overline{\text{DACK}}$ signal output</p> <p>1: Enables $\overline{\text{DACK}}$ signal output</p>
29	TENDE	0	R/W	<p>$\overline{\text{TEND}}$ Signal Output Enable</p> <p>Enables/disables the $\overline{\text{TEND}}$ signal output.</p> <p>0: Disables $\overline{\text{TEND}}$ signal output</p> <p>1: Enables $\overline{\text{TEND}}$ signal output</p>
28	—	0	R/W	<p>Reserved</p> <p>Initial value should not be changed.</p>
27	DREQS	0	R/W	<p>$\overline{\text{DREQ}}$ Select</p> <p>Selects whether a low level or the falling edge of the $\overline{\text{DREQ}}$ signal used in external request mode is detected.</p> <p>0: Low level detection</p> <p>1: Falling edge detection (the first transfer after a transfer enabled is detected on a low level)</p>
26	NRD	0	R/W	<p>Next Request Delay</p> <p>Selects the accepting timing of the next transfer request.</p> <p>0: Starts accepting the next transfer request after completion of the current transfer</p> <p>1: Starts accepting the next transfer request one cycle after completion of the current transfer</p>
25, 24	—	All 0	R	<p>Reserved</p> <p>These bits are always read as 0 and cannot be modified.</p>
23	ACT	0	R	<p>Active State</p> <p>Indicates the operating state for the channel.</p> <p>0: Waiting for a transfer request or a transfer disabled state by clearing the DTE bit to 0</p> <p>1: Active state</p>
22 to 20	—	All 0	R	<p>Reserved</p> <p>These bits are always read as 0 and cannot be modified.</p>

Bit	Bit Name	Initial Value	R/W	Description
19	ERRF	0	R/(W)*	<p>System Error Flag</p> <p>Indicates that an address error or an NMI interrupt has been generated. This bit is available only in DMDR_0. Setting this bit to 1 prohibits writing to the DTE bit for all the channels. This bit is reserved in DMDR_1 to DMDR_3. It is always read as 0 and cannot be modified.</p> <p>0: An address error or an NMI interrupt has not been generated</p> <p>1: An address error or an NMI interrupt has been generated</p> <p>[Clearing condition]</p> <ul style="list-style-type: none"> When clearing to 0 after reading ERRF = 1 <p>[Setting condition]</p> <ul style="list-style-type: none"> When an address error or an NMI interrupt has been generated <p>However, when an address error or an NMI interrupt has been generated in DMAC module stop mode, this bit is not set to 1.</p>
18	—	0	R	<p>Reserved</p> <p>This bit is always read as 0 and cannot be modified.</p>
17	ESIF	0	R/(W)*	<p>Transfer Escape Interrupt Flag</p> <p>Indicates that a transfer escape end interrupt has been requested. A transfer escape end means that a transfer is terminated before the transfer counter reaches 0.</p> <p>0: A transfer escape end interrupt has not been requested</p> <p>1: A transfer escape end interrupt has been requested</p> <p>[Clearing conditions]</p> <ul style="list-style-type: none"> When setting the DTE bit to 1 When clearing to 0 before reading ESIF = 1 <p>[Setting conditions]</p> <ul style="list-style-type: none"> When a transfer size error interrupt is requested When a repeat size end interrupt is requested When a transfer end interrupt by an extended repeat area overflow is requested

Bit	Bit Name	Initial Value	R/W	Description
16	DTIF	0	R/(W)*	<p>Data Transfer Interrupt Flag</p> <p>Indicates that a transfer end interrupt by the transfer counter has been requested.</p> <p>0: A transfer end interrupt by the transfer counter has not been requested</p> <p>1: A transfer end interrupt by the transfer counter has been requested</p> <p>[Clearing conditions]</p> <ul style="list-style-type: none"> • When setting the DTE bit to 1 • When clearing to 0 after reading DTIF = 1 <p>[Setting condition]</p> <ul style="list-style-type: none"> • When DTCR reaches 0 and the transfer is completed
15	DTSZ1	0	R/W	Data Access Size 1 and 0
14	DTSZ0	0	R/W	<p>Select the data access size for a transfer.</p> <p>00: Byte size (eight bits)</p> <p>01: Word size (16 bits)</p> <p>10: Longword size (32 bits)</p> <p>11: Setting prohibited</p>
13	MDS1	0	R/W	Transfer Mode Select 1 and 0
12	MDS0	0	R/W	<p>Select the transfer mode.</p> <p>00: Normal transfer mode</p> <p>01: Block transfer mode</p> <p>10: Repeat transfer mode</p> <p>11: Setting prohibited</p>

Bit	Bit Name	Initial Value	R/W	Description
11	TSEIE	0	R/W	<p>Transfer Size Error Interrupt Enable</p> <p>Enables/disables a transfer size error interrupt.</p> <p>When the next transfer is requested while this bit is set to 1 and the contents of the transfer counter is less than the size of data to be transferred at a single transfer request, the DTE bit is cleared to 0. At this time, the ESIF bit is set to 1 to indicate that a transfer size error interrupt has been requested.</p> <p>The sources of a transfer size error are as follows:</p> <ul style="list-style-type: none"> • In normal or repeat transfer mode, the total transfer size set in DTCR is less than the data access size • In block transfer mode, the total transfer size set in DTCR is less than the block size <p>0: Disables a transfer size error interrupt request 1: Enables a transfer size error interrupt request</p>
10	—	0	R	<p>Reserved</p> <p>This bit is always read as 0 and cannot be modified.</p>
9	ESIE	0	R/W	<p>Transfer Escape Interrupt Enable</p> <p>Enables/disables a transfer escape end interrupt request. When the ESIF bit is set to 1 with this bit set to 1, a transfer escape end interrupt is requested to the CPU or DTC. The transfer end interrupt request is cleared by clearing this bit or the ESIF bit to 0.</p> <p>0: Disables a transfer escape end interrupt 1: Enables a transfer escape end interrupt</p>
8	DTIE	0	R/W	<p>Data Transfer End Interrupt Enable</p> <p>Enables/disables a transfer end interrupt request by the transfer counter. When the DTIF bit is set to 1 with this bit set to 1, a transfer end interrupt is requested to the CPU or DTC. The transfer end interrupt request is cleared by clearing this bit or the DTIF bit to 0.</p> <p>0: Disables a transfer end interrupt 1: Enables a transfer end interrupt</p>

Bit	Bit Name	Initial Value	R/W	Description
7	DTF1	0	R/W	Data Transfer Factor 1 and 0
6	DTF0	0	R/W	Select a DMAC activation source. When the on-chip peripheral module setting is selected, the interrupt source should be selected by DMRSR. When the external request setting is selected, the sampling method should be selected by the DREQS bit. 00: Auto request (cycle stealing) 01: Auto request (burst access) 10: On-chip module interrupt 11: External request
5	DTA	0	R/W	Data Transfer Acknowledge This bit is valid in DMA transfer by the on-chip module interrupt source. This bit enables or disables to clear the source flag selected by DMRSR. 0: To clear the source in DMA transfer is disabled. Since the on-chip module interrupt source is not cleared in DMA transfer, it should be cleared by the CPU or DTC transfer. 1: To clear the source in DMA transfer is enabled. Since the on-chip module interrupt source is cleared in DMA transfer, it does not require an interrupt by the CPU or DTC transfer.
4, 3	—	All 0	R	Reserved These bits are always read as 0 and cannot be modified.

Bit	Bit Name	Initial Value	R/W	Description
2	DMAP2	0	R/W	DMA Priority Level 2 to 0
1	DMAP1	0	R/W	Select the priority level of the DMAC when using the CPU priority control function over DTC and DMAC.
0	DMAP0	0	R/W	When the CPU has priority over the DMAC, the DMAC masks a transfer request and waits for the timing when the CPU priority becomes lower than the DMAC priority. The priority levels can be set to the individual channels. This bit is valid when the CPUPCE bit in CPUPCR is set to 1. 000: Priority level 0 (low) 001: Priority level 1 010: Priority level 2 011: Priority level 3 100: Priority level 4 101: Priority level 5 110: Priority level 6 111: Priority level 7 (high)

Note: * Only 0 can be written to, to clear the flag.

10.3.7 DMA Address Control Register (DACR)

DACR specifies the operating mode and transfer method.

Bit	31	30	29	28	27	26	25	24
Bit Name	AMS	DIRS	—	—	—	RPTIE	ARS1	ARS0
Initial Value	0	0	0	0	0	0	0	0
R/W	R/W	R/W	R	R	R	R/W	R/W	R/W
Bit	23	22	21	20	19	18	17	16
Bit Name	—	—	SAT1	SAT0	—	—	DAT1	DAT0
Initial Value	0	0	0	0	0	0	0	0
R/W	R	R	R/W	R/W	R	R	R/W	R/W
Bit	15	14	13	12	11	10	9	8
Bit Name	SARIE	—	—	SARA4	SARA3	SARA2	SARA1	SARA0
Initial Value	0	0	0	0	0	0	0	0
R/W	R/W	R	R	R/W	R/W	R/W	R/W	R/W
Bit	7	6	5	4	3	2	1	0
Bit Name	DARIE	—	—	DARA4	DARA3	DARA2	DARA1	DARA0
Initial Value	0	0	0	0	0	0	0	0
R/W	R/W	R	R	R/W	R/W	R/W	R/W	R/W

Bit	Bit Name	Initial Value	R/W	Description
31	AMS	0	R/W	<p>Address Mode Select</p> <p>Selects address mode from single or dual address mode. In single address mode, the $\overline{\text{DACK}}$ pin is enabled according to the DACKE bit.</p> <p>0: Dual address mode 1: Single address mode</p>
30	DIRS	0	R/W	<p>Single Address Direction Select</p> <p>Specifies the data transfer direction in single address mode. This bit is ignored in dual address mode.</p> <p>0: Specifies DSAR as source address 1: Specifies DDAR as destination address</p>
29 to 27	—	0	R/W	<p>Reserved</p> <p>These bits are always read as 0 and cannot be modified.</p>

Bit	Bit Name	Initial Value	R/W	Description
26	RPTIE	0	R/W	<p>Repeat Size End Interrupt Enable</p> <p>Enables/disables a repeat size end interrupt request.</p> <p>In repeat transfer mode, when the next transfer is requested after completion of a 1-repeat-size data transfer while this bit is set to 1, the DTE bit in DMDR is cleared to 0. At this time, the ESIF bit in DMDR is set to 1 to indicate that a repeat size end interrupt is requested. Even when the repeat area is not specified (ARS1 = 1 and ARS0 = 0), a repeat size end interrupt after a 1-block data transfer can be requested.</p> <p>In addition, in block transfer mode, when the next transfer is requested after 1-block data transfer while this bit is set to 1, the DTE bit in DMDR is cleared to 0. At this time, the ESIF bit in DMDR is set to 1 to indicate that a repeat size end interrupt is requested.</p> <p>0: Disables a repeat size end interrupt 1: Enables a repeat size end interrupt</p>
25	ARS1	0	R/W	Area Select 1 and 0
24	ARS0	0	R/W	<p>Specify the block area or repeat area in block or repeat transfer mode.</p> <p>00: Specify the block area or repeat area on the source address 01: Specify the block area or repeat area on the destination address 10: Do not specify the block area or repeat area 11: Setting prohibited</p>
23, 22	—	All 0	R	<p>Reserved</p> <p>These bits are always read as 0 and cannot be modified.</p>
21	SAT1	0	R/W	Source Address Update Mode 1 and 0
20	SAT0	0	R/W	<p>Select the update method of the source address (DSAR). When DSAR is not specified as the transfer source in single address mode, this bit is ignored.</p> <p>00: Source address is fixed 01: Source address is updated by adding the offset 10: Source address is updated by adding 1, 2, or 4 according to the data access size 11: Source address is updated by subtracting 1, 2, or 4 according to the data access size</p>

Bit	Bit Name	Initial Value	R/W	Description
19, 18	—	All 0	R	Reserved These bits are always read as 0 and cannot be modified.
17	DAT1	0	R/W	Destination Address Update Mode 1 and 0
16	DAT0	0	R/W	Select the update method of the destination address (DDAR). When DDAR is not specified as the transfer destination in single address mode, this bit is ignored. 00: Destination address is fixed 01: Destination address is updated by adding the offset 10: Destination address is updated by adding 1, 2, or 4 according to the data access size 11: Destination address is updated by subtracting 1, 2, or 4 according to the data access size
15	SARIE	0	R/W	Interrupt Enable for Source Address Extended Area Overflow Enables/disables an interrupt request for an extended area overflow on the source address. When an extended repeat area overflow on the source address occurs while this bit is set to 1, the DTE bit in DMDR is cleared to 0. At this time, the ESIF bit in DMDR is set to 1 to indicate an interrupt by an extended repeat area overflow on the source address is requested. When block transfer mode is used with the extended repeat area function, an interrupt is requested after completion of a 1-block size transfer. When setting the DTE bit in DMDR of the channel for which a transfer has been stopped to 1, the transfer is resumed from the state when the transfer is stopped. When the extended repeat area is not specified, this bit is ignored. 0: Disables an interrupt request for an extended area overflow on the source address 1: Enables an interrupt request for an extended area overflow on the source address
14, 13	—	All 0	R	Reserved These bits are always read as 0 and cannot be modified.

Bit	Bit Name	Initial Value	R/W	Description
12	SARA4	0	R/W	Source Address Extended Repeat Area
11	SARA3	0	R/W	Specify the extended repeat area on the source address (DSAR). With the extended repeat area, the specified lower address bits are updated and the remaining upper address bits are fixed. The extended repeat area size is specified from four bytes to 128 Mbytes in units of byte and a power of 2. When the lower address is overflowed from the extended repeat area by address update, the address becomes the start address and the end address of the area for address addition and subtraction, respectively. When an overflow in the extended repeat area occurs with the SARIE bit set to 1, an interrupt can be requested. Table 10.3 shows the settings and areas of the extended repeat area.
10	SARA2	0	R/W	
9	SARA1	0	R/W	
8	SARA0	0	R/W	
7	DARIE	0	R/W	Destination Address Extended Repeat Area Overflow Interrupt Enable Enables/disables an interrupt request for an extended area overflow on the destination address. When an extended repeat area overflow on the destination address occurs while this bit is set to 1, the DTE bit in DMDR is cleared to 0. At this time, the ESIF bit in DMDR is set to 1 to indicate an interrupt by an extended repeat area overflow on the destination address is requested. When block transfer mode is used with the extended repeat area function, an interrupt is requested after completion of a 1-block size transfer. When setting the DTE bit in DMDR of the channel for which the transfer has been stopped to 1, the transfer is resumed from the state when the transfer is stopped. When the extended repeat area is not specified, this bit is ignored. 0: Disables an interrupt request for an extended area overflow on the destination address 1: Enables an interrupt request for an extended area overflow on the destination address
6, 5	—	All 0	R	Reserved These bits are always read as 0 and cannot be modified.

Bit	Bit Name	Initial Value	R/W	Description
4	DARA4	0	R/W	Destination Address Extended Repeat Area
3	DARA3	0	R/W	Specify the extended repeat area on the destination address (DDAR). With the extended repeat area, the specified lower address bits are updated and the remaining upper address bits are fixed. The extended repeat area size is specified from four bytes to 128 Mbytes in units of byte and a power of 2. When the lower address is overflowed from the extended repeat area by address update, the address becomes the start address and the end address of the area for address addition and subtraction, respectively. When an overflow in the extended repeat area occurs with the DARIE bit set to 1, an interrupt can be requested. Table 10.3 shows the settings and areas of the extended repeat area.
2	DARA2	0	R/W	
1	DARA1	0	R/W	
0	DARA0	0	R/W	

Table 10.3 Settings and Areas of Extended Repeat Area

SARA4 to SARA0 or DARA4 to DARA0	Extended Repeat Area
00000	Not specified
00001	2 bytes specified as extended repeat area by the lower 1 bit of the address
00010	4 bytes specified as extended repeat area by the lower 2 bits of the address
00011	8 bytes specified as extended repeat area by the lower 3 bits of the address
00100	16 bytes specified as extended repeat area by the lower 4 bits of the address
00101	32 bytes specified as extended repeat area by the lower 5 bits of the address
00110	64 bytes specified as extended repeat area by the lower 6 bits of the address
00111	128 bytes specified as extended repeat area by the lower 7 bits of the address
01000	256 bytes specified as extended repeat area by the lower 8 bits of the address
01001	512 bytes specified as extended repeat area by the lower 9 bits of the address
01010	1 kbyte specified as extended repeat area by the lower 10 bits of the address
01011	2 kbytes specified as extended repeat area by the lower 11 bits of the address
01100	4 kbytes specified as extended repeat area by the lower 12 bits of the address
01101	8 kbytes specified as extended repeat area by the lower 13 bits of the address
01110	16 kbytes specified as extended repeat area by the lower 14 bits of the address
01111	32 kbytes specified as extended repeat area by the lower 15 bits of the address
10000	64 kbytes specified as extended repeat area by the lower 16 bits of the address
10001	128 kbytes specified as extended repeat area by the lower 17 bits of the address
10010	256 kbytes specified as extended repeat area by the lower 18 bits of the address
10011	512 kbytes specified as extended repeat area by the lower 19 bits of the address
10100	1 Mbyte specified as extended repeat area by the lower 20 bits of the address
10101	2 Mbytes specified as extended repeat area by the lower 21 bits of the address
10110	4 Mbytes specified as extended repeat area by the lower 22 bits of the address
10111	8 Mbytes specified as extended repeat area by the lower 23 bits of the address
11000	16 Mbytes specified as extended repeat area by the lower 24 bits of the address
11001	32 Mbytes specified as extended repeat area by the lower 25 bits of the address
11010	64 Mbytes specified as extended repeat area by the lower 26 bits of the address
11011	128 Mbytes specified as extended repeat area by the lower 27 bits of the address
111××	Setting prohibited

[Legend]

×: Don't care

10.3.8 DMA Module Request Select Register (DMRSR)

DMRSR is an 8-bit readable/writable register that specifies the on-chip module interrupt source. The vector number of the interrupt source is specified in eight bits. However, 0 is regarded as no interrupt source. For the vector numbers of the interrupt sources, refer to Table 10.5.

Bit	7	6	5	4	3	2	1	0
Bit Name								
Initial Value	0	0	0	0	0	0	0	0
R/W	R/W	R/W	R/W	R/W	R/W	R/W	R/W	R/W

10.4 Transfer Modes

Table 10.4 shows the DMAC transfer modes. The transfer modes can be specified to the individual channels.

Table 10.4 Transfer Modes

Address Mode	Transfer mode	Activation Source	Common Function	Address Register	
				Source	Destination
Dual address	<ul style="list-style-type: none"> Normal transfer Repeat transfer Block transfer Repeat or block size = 1 to 65,536 bytes, 1 to 65,536 words, or 1 to 65,536 longwords	<ul style="list-style-type: none"> Auto request (activated by CPU) On-chip module interrupt External request 	<ul style="list-style-type: none"> Total transfer size: 1 to 4 Gbytes or not specified Offset addition Extended repeat area function 	DSAR	DDAR
Single address	<ul style="list-style-type: none"> Instead of specifying the source or destination address registers, data is directly transferred from/to the external device using the $\overline{\text{DACK}}$ pin The same settings as above are available other than address register setting (e.g., above transfer modes can be specified) One transfer can be performed in one bus cycle (the types of transfer modes are the same as those of dual address modes) 			DSAR/ $\overline{\text{DACK}}$	$\overline{\text{DACK}}$ / DDAR

When the auto request setting is selected as the activation source, the cycle stealing or burst access can be selected. When the total transfer size is not specified (DTCR = H'00000000), the transfer counter is stopped and the transfer is continued without the limitation of the transfer count.

10.5 Operations

10.5.1 Address Modes

(1) Dual Address Mode

In dual address mode, the transfer source address is specified in DSAR and the transfer destination address is specified in DDAR. A transfer at a time is performed in two bus cycles (when the data bus width is less than the data access size or the access address is not aligned with the boundary of the data access size, the number of bus cycles are needed more than two because one bus cycle is divided into multiple bus cycles).

In the first bus cycle, data at the transfer source address is read and in the next cycle, the read data is written to the transfer destination address.

The read and write cycles are not separated. Other bus cycles (bus cycle by other bus masters, refresh cycle, and external bus release cycle) are not generated between read and write cycles.

The $\overline{\text{TEND}}$ signal output is enabled or disabled by the TENDE bit in DMDR. The $\overline{\text{TEND}}$ signal is output in two bus cycles. When an idle cycle is inserted before the bus cycle, the $\overline{\text{TEND}}$ signal is also output in the idle cycle. The $\overline{\text{DACK}}$ signal is not output.

Figure 10.2 shows an example of the signal timing in dual address mode and Figure 10.3 shows the operation in dual address mode.

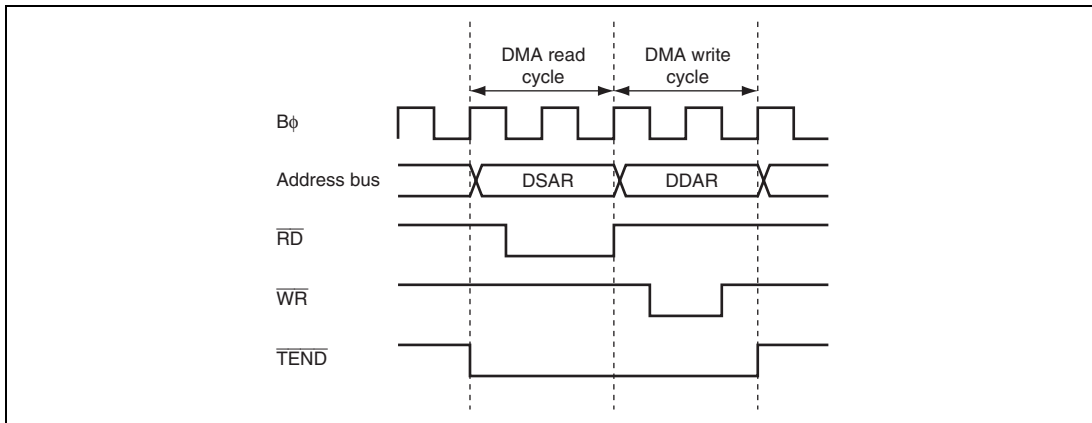

Figure 10.2 Example of Signal Timing in Dual Address Mode

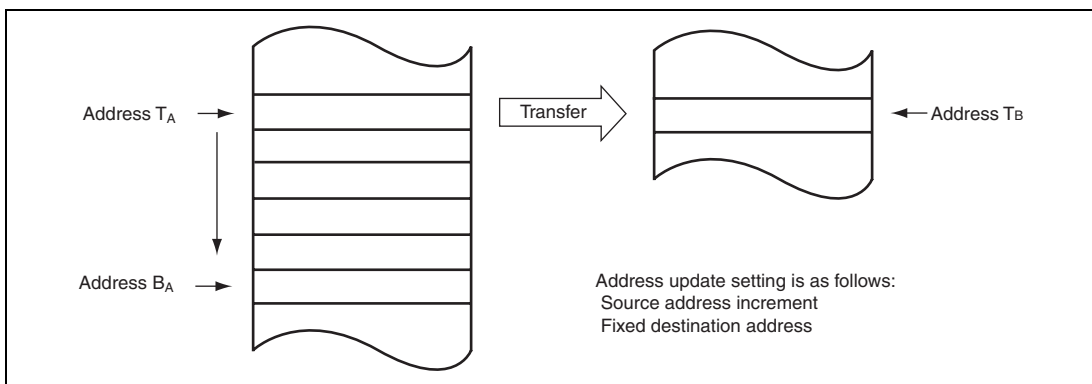

Figure 10.3 Operations in Dual Address Mode

(2) Single Address Mode

In single address mode, data between an external device and an external memory is directly transferred using the $\overline{\text{DACK}}$ pin instead of DSAR or DDAR. A transfer at a time is performed in one bus cycle. In this mode, the data bus width must be the same as the data access size. For details on the data bus width, see section 9, Bus Controller (BSC).

The DMAC accesses an external device as the transfer source or destination by outputting the strobe signal ($\overline{\text{DACK}}$) to the external device with $\overline{\text{DACK}}$ and accesses the other transfer target by outputting the address. Accordingly, the DMA transfer is performed in one bus cycle. Figure 10.4 shows an example of a transfer between an external memory and an external device with the $\overline{\text{DACK}}$ pin. In this example, the external device outputs data on the data bus and the data is written to the external memory in the same bus cycle.

The transfer direction is decided by the DIRS bit in DACR which specifies an external device with the $\overline{\text{DACK}}$ pin as the transfer source or destination. When $\text{DIRS} = 0$, data is transferred from an external memory (DSAR) to an external device with the $\overline{\text{DACK}}$ pin. When $\text{DIRS} = 1$, data is transferred from an external device with the $\overline{\text{DACK}}$ pin to an external memory (DDAR). The settings of registers which are not used as the transfer source or destination are ignored.

The $\overline{\text{DACK}}$ signal output is enabled in single address mode by the DACKE bit in DMDR. The $\overline{\text{DACK}}$ signal is low active.

The $\overline{\text{TEND}}$ signal output is enabled or disabled by the TENDE bit in DMDR. The $\overline{\text{TEND}}$ signal is output in one bus cycle. When an idle cycle is inserted before the bus cycle, the $\overline{\text{TEND}}$ signal is also output in the idle cycle.

Figure 10.5 shows an example of timing charts in single address mode and Figure 10.6 shows an example of operation in single address mode.

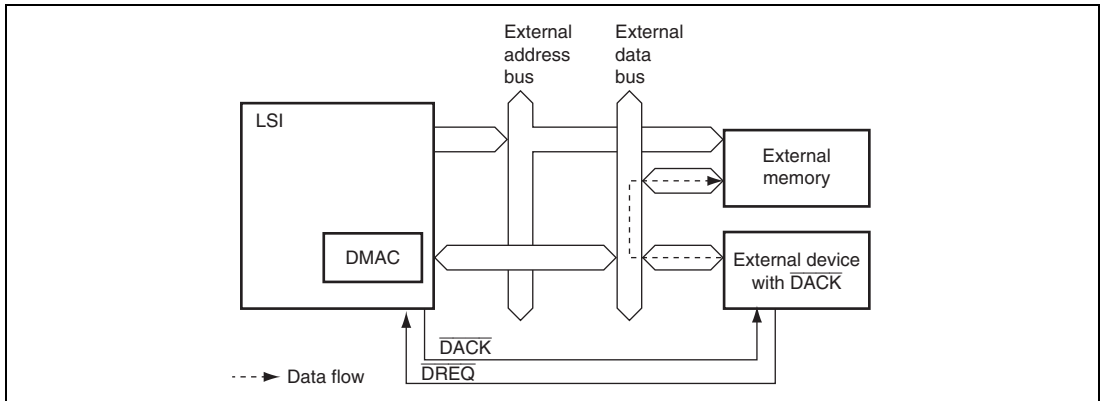

Figure 10.4 Data Flow in Single Address Mode

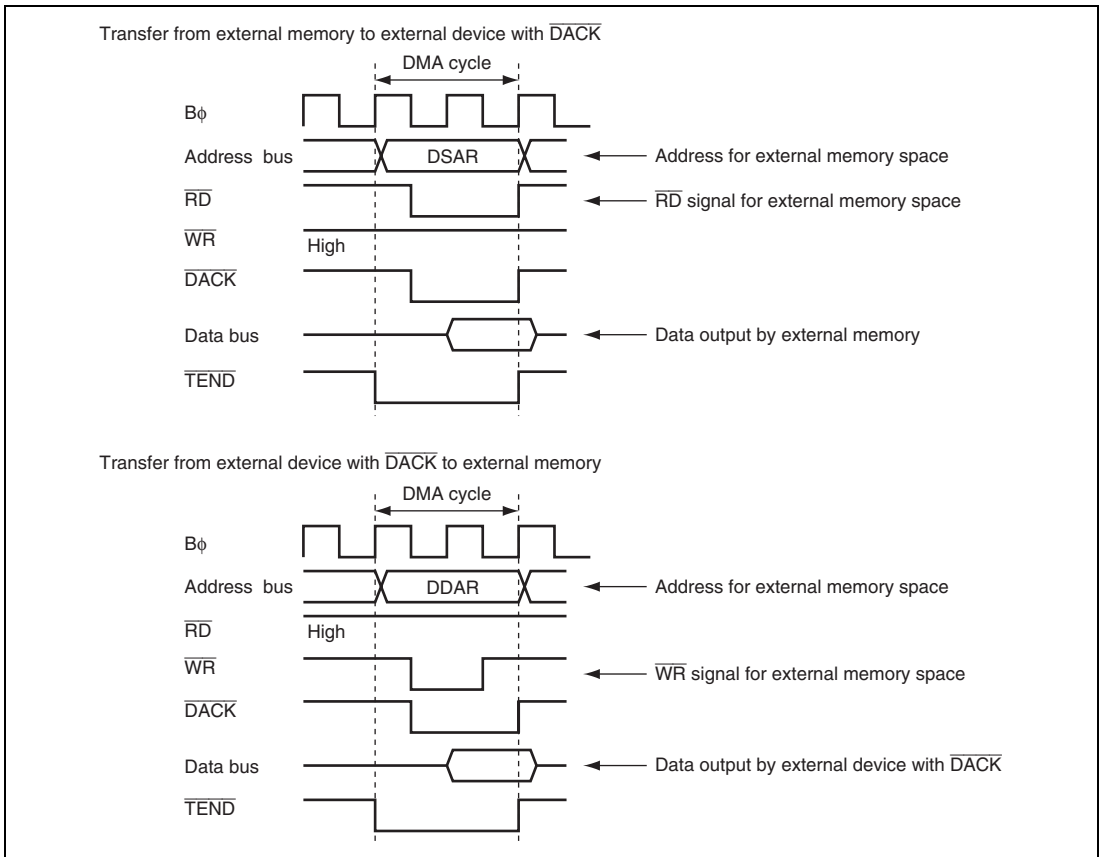

Figure 10.5 Example of Signal Timing in Single Address Mode

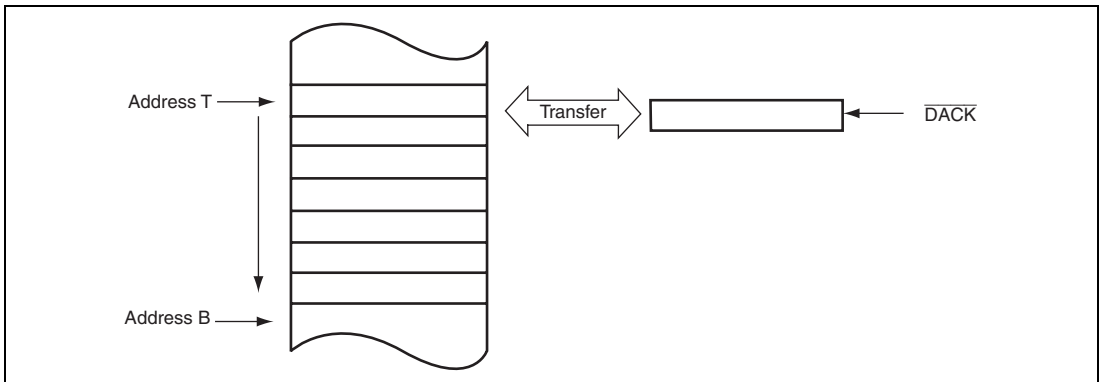

Figure 10.6 Operations in Single Address Mode

10.5.2 Transfer Modes

(1) Normal Transfer Mode

In normal transfer mode, one data access size of data is transferred at a single transfer request. Up to 4 Gbytes can be specified as a total transfer size by DTCCR. DBSR is ignored in normal transfer mode.

The $\overline{\text{TEND}}$ signal is output only in the last DMA transfer.

Figure 10.7 shows an example of the signal timing in normal transfer mode and Figure 10.8 shows the operation in normal transfer mode.

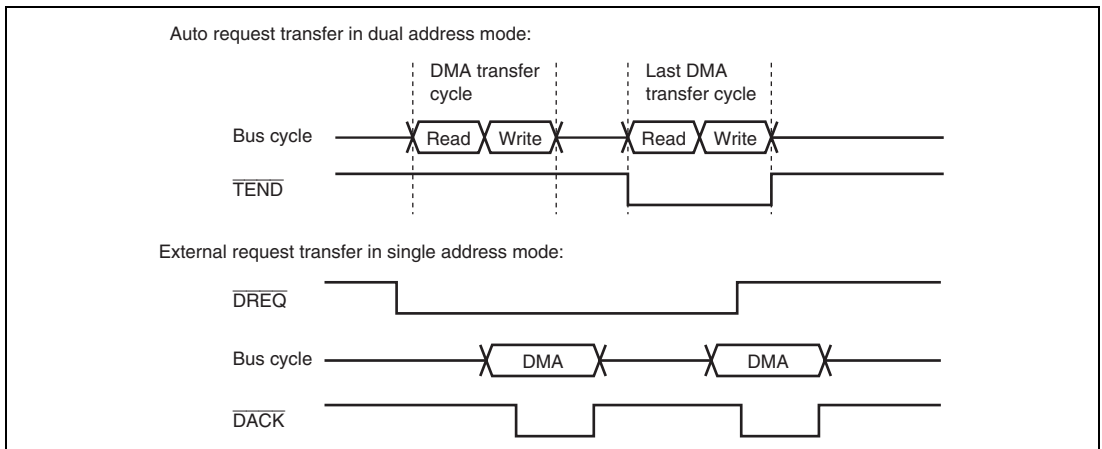

Figure 10.7 Example of Signal Timing in Normal Transfer Mode

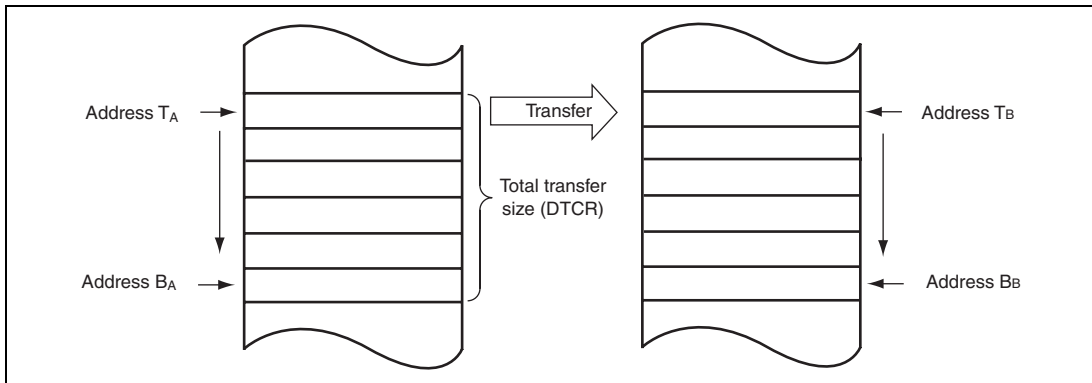

Figure 10.8 Operations in Normal Transfer Mode

(2) Repeat Transfer Mode

In repeat transfer mode, one data access size of data is transferred at a single transfer request. Up to 4 Gbytes can be specified as a total transfer size by DTCR. The repeat size can be specified in DBSR up to $65536 \times$ data access size.

The repeat area can be specified for the source or destination address side by bits ARS1 and ARS0 in DACR. The address specified as the repeat area returns to the transfer start address when the repeat size of transfers is completed. This operation is repeated until the total transfer size specified in DTCR is completed. When H'00000000 is specified in DTCR, it is regarded as the free running mode and repeat transfer is continued until the DTE bit in DMDR is cleared to 0.

In addition, a DMA transfer can be stopped and a repeat size end interrupt can be requested to the CPU or DTC when the repeat size of transfers is completed. When the next transfer is requested after completion of a 1-repeat size data transfer while the RPTIE bit is set to 1, the DTE bit in DMDR is cleared to 0 and the ESIF bit in DMDR is set to 1 to complete the transfer. At this time, an interrupt is requested to the CPU or DTC when the ESIE bit in DMDR is set to 1.

The timings of the \overline{TEND} signals are the same as in normal transfer mode.

Figure 10.9 shows the operation in repeat transfer mode while dual address mode is set.

When the repeat area is specified as neither source nor destination address side, the operation is the same as the normal transfer mode operation shown in Figure 10.8. In this case, a repeat size end interrupt can also be requested to the CPU when the repeat size of transfers is completed.

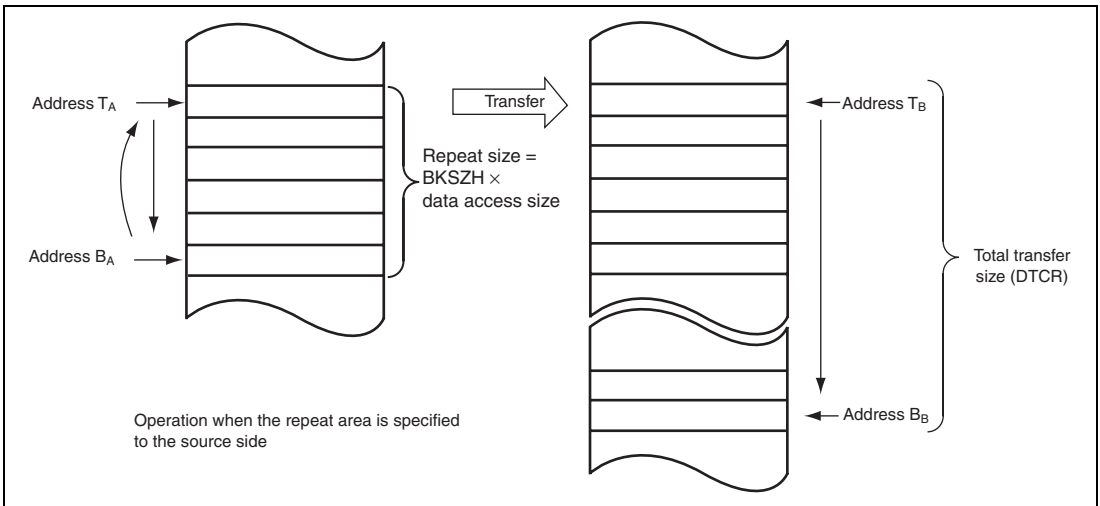

Figure 10.9 Operations in Repeat Transfer Mode

(3) Block Transfer Mode

In block transfer mode, one block size of data is transferred at a single transfer request. Up to 4 Gbytes can be specified as total transfer size by DTCR. The block size can be specified in DBSR up to $65536 \times$ data access size.

While one block of data is being transferred, transfer requests from other channels are suspended. When the transfer is completed, the bus is released to the other bus master.

The block area can be specified for the source or destination address side by bits ARS1 and ARS0 in DACR. The address specified as the block area returns to the transfer start address when the block size of data is completed. When the block area is specified as neither source nor destination address side, the operation continues without returning the address to the transfer start address. A repeat size end interrupt can be requested.

The $\overline{\text{TEND}}$ signal is output every time 1-block data is transferred in the last DMA transfer cycle.

When an interrupt request by an extended repeat area overflow is used in block transfer mode, settings should be selected carefully. For details, see section 10.5.5, Extended Repeat Area Function.

Figure 10.10 shows an example of the DMA transfer timing in block transfer mode. The transfer conditions are as follows:

- Address mode: single address mode
- Data access size: byte
- 1-block size: three bytes

The block transfer mode operations in single address mode and in dual address mode are shown in figures 10.11 and 10.12, respectively.

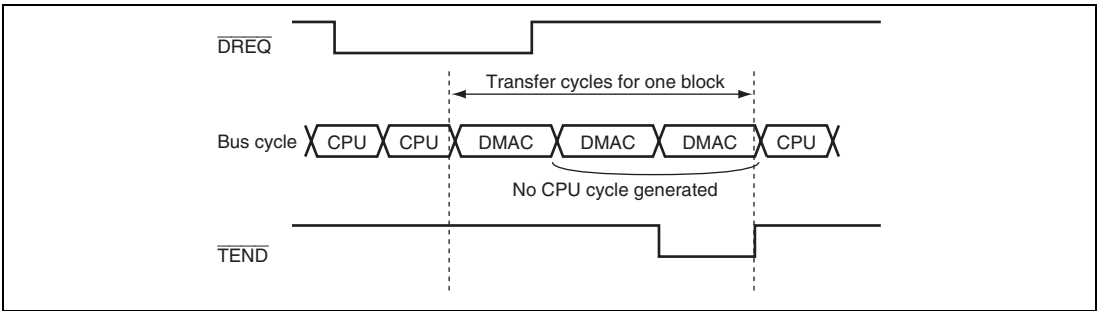

Figure 10.10 Operations in Block Transfer Mode

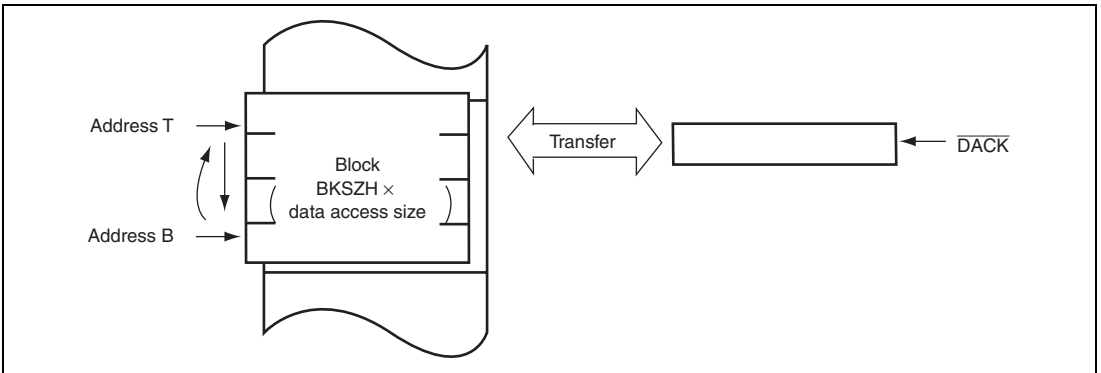
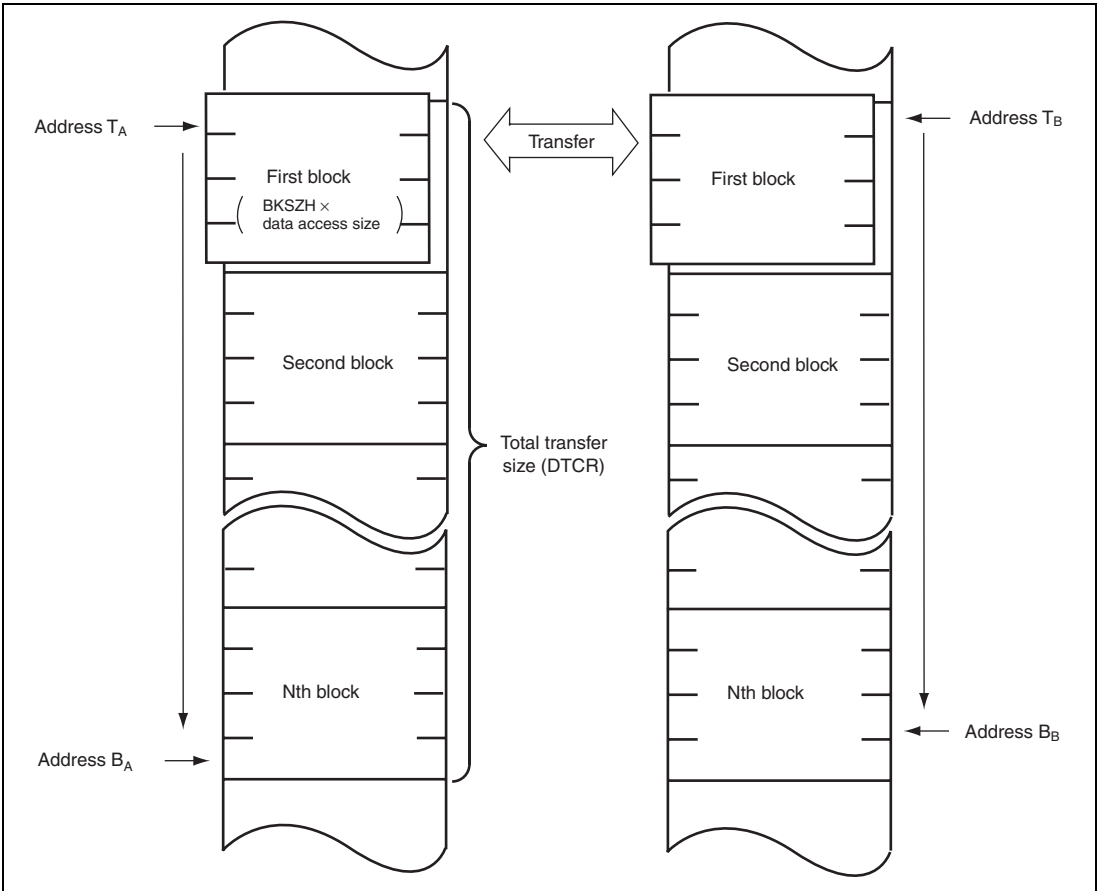

Figure 10.11 Operation in Single Address Mode in Block Transfer Mode (Block Area Specified)



**Figure 10.12 Operation in Dual Address Mode in Block Transfer Mode
(Block Area Not Specified)**

10.5.3 Activation Sources

The DMAC is activated by an auto request, an on-chip module interrupt, and an external request. The activation source is specified by bits DTF1 and DTF0 in DMDR.

(1) Activation by Auto Request

The auto request activation is used when a transfer request from an external device or an on-chip peripheral module is not generated such as a transfer between memory and memory or between memory and an on-chip peripheral module which does not request a transfer. A transfer request is automatically generated inside the DMAC. In auto request activation, setting the DTE bit in DMDR starts a transfer. The bus mode can be selected from cycle stealing and burst modes.

(2) Activation by On-Chip Module Interrupt

An interrupt request from an on-chip peripheral module (on-chip peripheral module interrupt) is used as a transfer request. When a DMA transfer is enabled ($DTE = 1$), the DMA transfer is started by an on-chip module interrupt.

The activation source of the on-chip module interrupt is selected by the DMA module request select register (DMRSR). The activation sources are specified to the individual channels. Table 10.5 is a list of on-chip module interrupts for the DMAC. The interrupt request selected as the activation source can generate an interrupt request simultaneously to the CPU or DTC. For details, refer to section 7, Interrupt Controller.

The DMAC receives interrupt requests by on-chip peripheral modules independent of the interrupt controller. Therefore, the DMAC is not affected by priority given in the interrupt controller.

When the DMAC is activated while $DTA = 1$, the interrupt request flag is automatically cleared by a DMA transfer. If multiple channels use a single transfer request as an activation source, when the channel having priority is activated, the interrupt request flag is cleared. In this case, other channels may not be activated because the transfer request is not held in the DMAC.

When the DMAC is activated while $DTA = 0$, the interrupt request flag is not cleared by the DMAC and should be cleared by the CPU or DTC transfer.

When an activation source is selected while $DTE = 0$, the activation source does not request a transfer to the DMAC. It requests an interrupt to the CPU or DTC.

In addition, make sure that an interrupt request flag as an on-chip module interrupt source is cleared to 0 before writing 1 to the DTE bit.

Table 10.5 List of On-chip module interrupts to DMAC

On-Chip Module Interrupt Source	On-Chip Module	DMRSR (Vector Number)
ADI0 (conversion end interrupt for A/D converter unit 0)	A/D_0	86
TGI0A (TGI0A input capture/compare match)	TPU_0	88
TGI1A (TGI1A input capture/compare match)	TPU_1	93
TGI2A (TGI2A input capture/compare match)	TPU_2	97
TGI3A (TGI3A input capture/compare match)	TPU_3	101
TGI4A (TGI4A input capture/compare match)	TPU_4	106
TGI5A (TGI5A input capture/compare match)	TPU_5	110
RX10 (receive data full interrupt for SCI channel 0)	SCI_0	145
TX10 (transmit data empty interrupt for SCI channel 0)	SCI_0	146
RX11 (receive data full interrupt for SCI channel 1)	SCI_1	149
TX11 (transmit data empty interrupt for SCI channel 1)	SCI_1	150
RX12 (receive data full interrupt for SCI channel 2)	SCI_2	153
TX12 (transmit data empty interrupt for SCI channel 2)	SCI_2	154
RX13 (receive data full interrupt for SCI channel 3)	SCI_3	157
TX13 (transmit data empty interrupt for SCI channel 3)	SCI_3	158
RX14 (receive data full interrupt for SCI channel 4)	SCI_4	161
TX14 (transmit data empty interrupt for SCI channel 4)	SCI_4	162
TGI6A (TGI6A input capture/compare match)	TPU_6	164
TGI7A (TGI7A input capture/compare match)	TPU_7	169
TGI8A (TGI8A input capture/compare match)	TPU_8	173
TGI9A (TGI9A input capture/compare match)	TPU_9	177
TGI10A (TGI10A input capture/compare match)	TPU_10	182
TGI11A (TGI11A input capture/compare match)	TPU_11	188
RX15 (receive data full interrupt for SCI channel 5)	SCI_5	220
TX15 (transmit data empty interrupt for SCI channel 5)	SCI_5	221
RX16 (receive data full interrupt for SCI channel 6)	SCI_6	224
TX16 (transmit data empty interrupt for SCI channel 6)	SCI_6	225
ADI1 (conversion end interrupt for A/D converter unit 1)	A/D_1	237

(3) Activation by External Request

A transfer is started by a transfer request signal ($\overline{\text{DREQ}}$) from an external device. When a DMA transfer is enabled ($\text{DTE} = 1$), the DMA transfer is started by the $\overline{\text{DREQ}}$ assertion. When a DMA transfer between on-chip peripheral modules is performed, select an activation source from the auto request and on-chip module interrupt (the external request cannot be used).

A transfer request signal is input to the $\overline{\text{DREQ}}$ pin. The $\overline{\text{DREQ}}$ signal is detected on the falling edge or low level. Whether the falling edge or low level detection is used is selected by the DREQS bit in DMDR .

When an external request is selected as an activation source, clear the DDR bit to 0 and set the ICR bit to 1 for the corresponding pin. For details, see section 12, I/O Ports.

10.5.4 Bus Access Modes

There are two types of bus access modes: cycle stealing and burst.

When an activation source is the auto request, the cycle stealing or burst mode is selected by bit DTFO in DMDR . When an activation source is the on-chip module interrupt or external request, the cycle stealing mode is selected.

(1) Cycle Stealing Mode

In cycle stealing mode, the DMAC releases the bus every time one unit of transfers (byte, word, longword, or 1-block size) is completed. After that, when a transfer is requested, the DMAC obtains the bus to transfer 1-unit data and then releases the bus on completion of the transfer. This operation is continued until the transfer end condition is satisfied.

When a transfer is requested to another channel during a DMA transfer, the DMAC releases the bus and then transfers data for the requested channel. For details on operations when a transfer is requested to multiple channels, see section 10.5.8, Priority of Channels.

Figure 10.13 shows an example of timing in cycle stealing mode. The transfer conditions are as follows:

- Address mode: Single address mode
- Sampling method of the $\overline{\text{DREQ}}$ signal: Low level detection

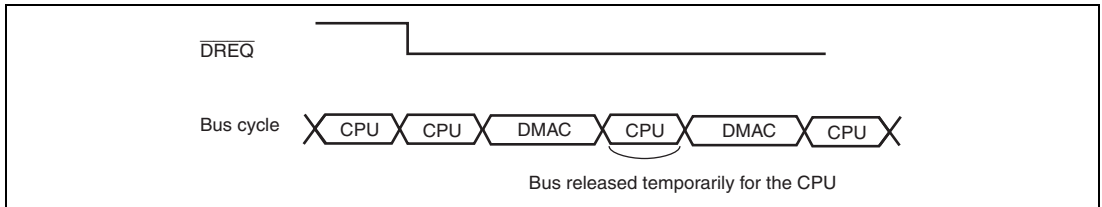

Figure 10.13 Example of Timing in Cycle Stealing Mode

(2) Burst Access Mode

In burst mode, once it takes the bus, the DMAC continues a transfer without releasing the bus until the transfer end condition is satisfied. Even if a transfer is requested from another channel having priority, the transfer is not stopped once it is started. The DMAC releases the bus in the next cycle after the transfer for the channel in burst mode is completed. This is similarly to operation in cycle stealing mode. However, setting the IBCCS bit in BCR2 of the bus controller makes the DMAC release the bus to pass the bus to another bus master.

In block transfer mode, the burst mode setting is ignored (operation is the same as that in burst mode during one block of transfers). The DMAC is always operated in cycle stealing mode.

Clearing the DTE bit in DMDR stops a DMA transfer. A transfer requested before the DTE bit is cleared to 0 by the DMAC is executed. When an interrupt by a transfer size error, a repeat size end, or an extended repeat area overflow occurs, the DTE bit is cleared to 0 and the transfer ends.

Figure 10.14 shows an example of timing in burst mode.

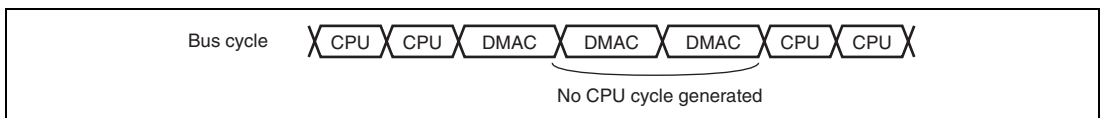

Figure 10.14 Example of Timing in Burst Mode

10.5.5 Extended Repeat Area Function

The source and destination address sides can be specified as the extended repeat area. The contents of the address register repeat addresses within the area specified as the extended repeat area. For example, to use a ring buffer as the transfer target, the contents of the address register should return to the start address of the buffer every time the contents reach the end address of the buffer (overflow on the ring buffer address). This operation can automatically be performed using the extended repeat area function of the DMAC.

The extended repeat areas can be specified independently to the source address register (DSAR) and destination address register (DDAR).

The extended repeat area on the source address is specified by bits SARA4 to SARA0 in DACR. The extended repeat area on the destination address is specified by bits DARA4 to DARA0 in DACR. The extended repeat area sizes for each side can be specified independently.

A DMA transfer is stopped and an interrupt by an extended repeat area overflow can be requested to the CPU when the contents of the address register reach the end address of the extended repeat area. When an overflow on the extended repeat area set in DSAR occurs while the SARIE bit in DACR is set to 1, the ESIF bit in DMDR is set to 1 and the DTE bit in DMDR is cleared to 0 to stop the transfer. At this time, if the ESIE bit in DMDR is set to 1, an interrupt by an extended repeat area overflow is requested to the CPU. When the DARIE bit in DACR is set to 1, an overflow on the extended repeat area set in DDAR occurs, meaning that the destination side is a target. During the interrupt handling, setting the DTE bit in DMDR resumes the transfer.

Figure 10.15 shows an example of the extended repeat area operation.

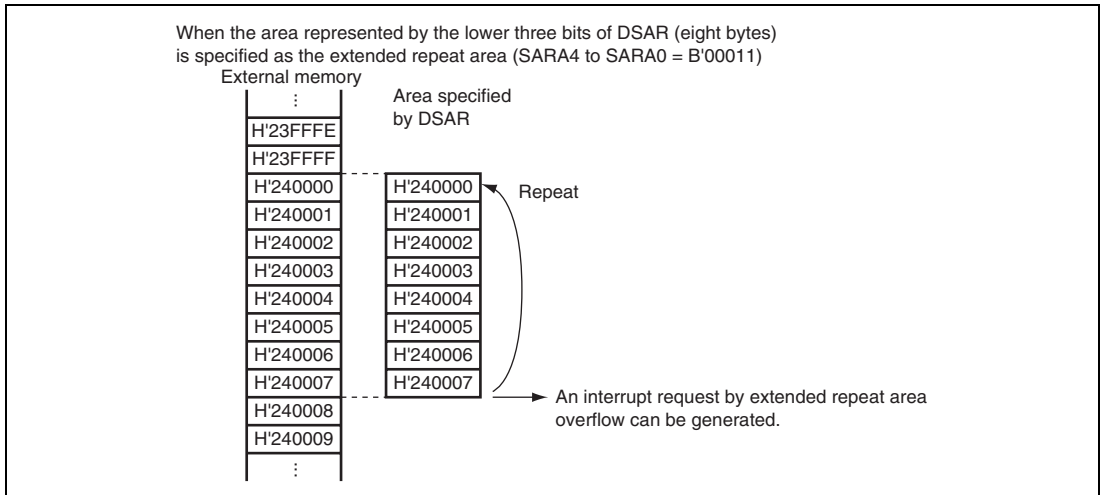

Figure 10.15 Example of Extended Repeat Area Operation

When an interrupt by an extended repeat area overflow is used in block transfer mode, the following should be taken into consideration.

When a transfer is stopped by an interrupt by an extended repeat area overflow, the address register must be set so that the block size is a power of 2 or the block size boundary is aligned with the extended repeat area boundary. When an overflow on the extended repeat area occurs during a transfer of one block, the interrupt by the overflow is suspended and the transfer overruns.

Figure 10.16 shows examples when the extended repeat area function is used in block transfer mode.

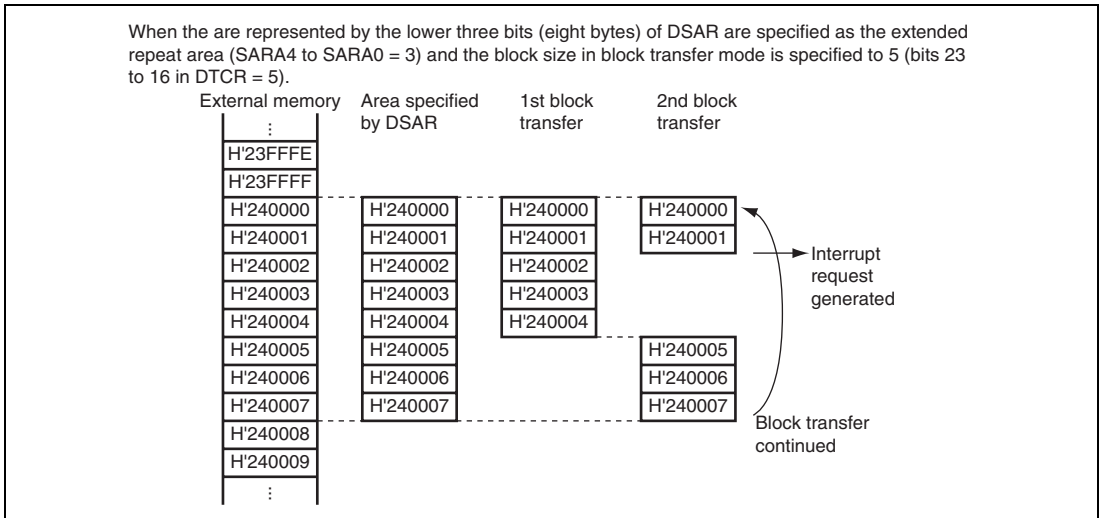

Figure 10.16 Example of Extended Repeat Area Function in Block Transfer Mode

10.5.6 Address Update Function using Offset

The source and destination addresses are updated by fixing, increment/decrement by 1, 2, or 4, or offset addition. When the offset addition is selected, the offset specified by the offset register (DOFR) is added to the address every time the DMAC transfers the data access size of data. This function realizes a data transfer where addresses are allocated to separated areas.

Figure 10.17 shows the address update method.

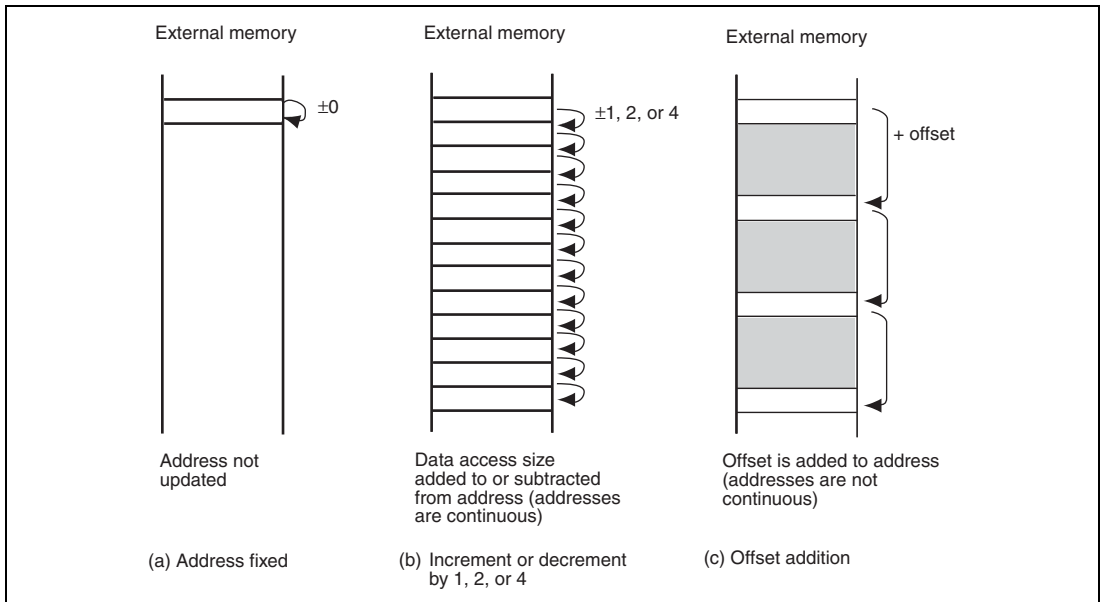

Figure 10.17 Address Update Method

In item (a), Address fixed, the transfer source or destination address is not updated indicating the same address.

In item (b), Increment or decrement by 1, 2, or 4, the transfer source or destination address is incremented or decremented by the value according to the data access size at each transfer. Byte, word, or longword can be specified as the data access size. The value of 1 for byte, 2 for word, and 4 for longword is used for updating the address. This operation realizes the data transfer placed in consecutive areas.

In item (c), Offset addition, the address update does not depend on the data access size. The offset specified by DOFR is added to the address every time the DMAC transfers data of the data access size.

The address is calculated by the offset set in DOFR and the contents of DSAR and DDAR. Although the DMAC calculates only addition, an offset subtraction can be realized by setting the negative value in DOFR. In this case, the negative value must be 2's complement.

(1) Basic Transfer Using Offset

Figure 10.18 shows a basic operation of a transfer using the offset addition.

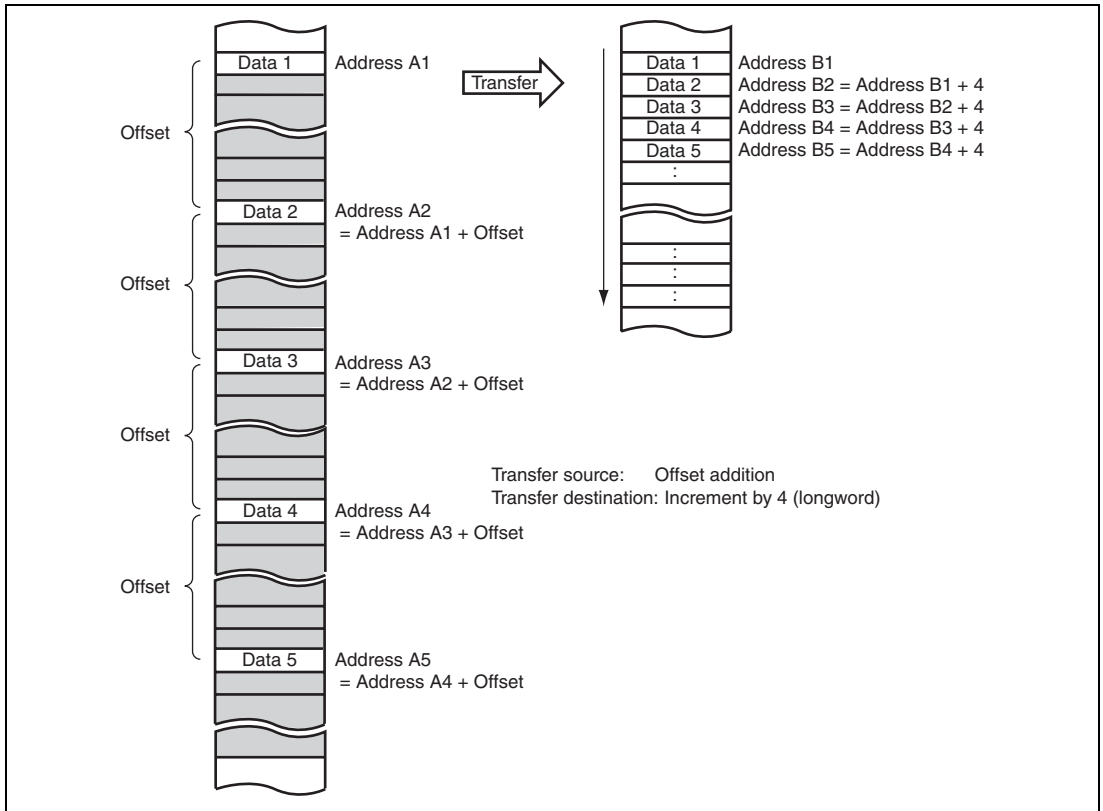

Figure 10.18 Operation of Offset Addition

In Figure 10.18, the offset addition is selected as the transfer source address update and increment or decrement by 1, 2, or 4 is selected as the transfer destination address. The address update means that data at the address which is away from the previous transfer source address by the offset is read from. The data read from the address away from the previous address is written to the consecutive area in the destination side.

(2) XY Conversion Using Offset

Figure 10.19 shows the XY conversion using the offset addition in repeat transfer mode.

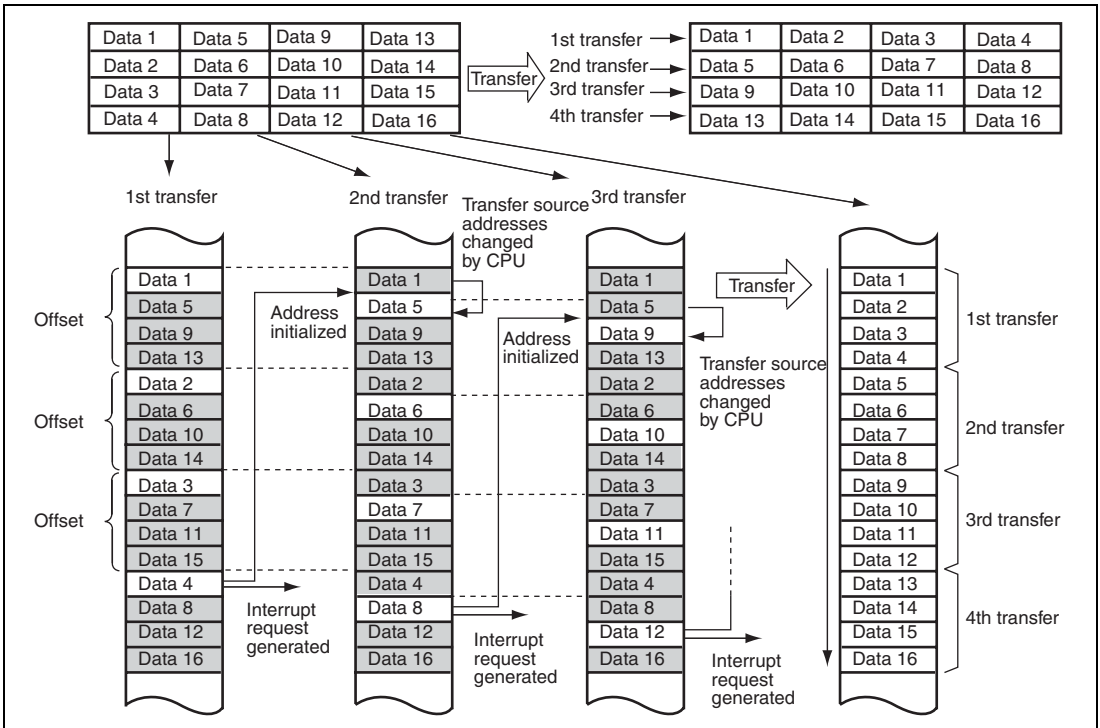

Figure 10.19 XY Conversion Operation Using Offset Addition in Repeat Transfer Mode

In Figure 10.19, the source address side is specified to the repeat area by DACR and the offset addition is selected. The offset value is set to $4 \times$ data access size (when the data access size is longword, H'00000010 is set in DOFR, as an example). The repeat size is set to $4 \times$ data access size (when the data access size is longword, the repeat size is set to $4 \times 4 = 16$ bytes, as an example). The increment or decrement by 1, 2, or 4 is specified as the transfer destination address. A repeat size end interrupt is requested when the RPTIE bit in DACR is set to 1 and the repeat size of transfers is completed.

When a transfer starts, the transfer source address is added to the offset every time data is transferred. The transfer data is written to the destination continuous addresses. When data 4 is transferred meaning that the repeat size of transfers is completed, the transfer source address returns to the transfer start address (address of data 1 on the transfer source) and a repeat size end interrupt is requested. While this interrupt stops the transfer temporarily, the contents of DSAR are written to the address of data 5 by the CPU (when the data access size is longword, write the data 1 address + 4). When the DTE bit in DMDR is set to 1, the transfer is resumed from the state when the transfer is stopped. Accordingly, operations are repeated and the transfer source data is transposed to the destination area (XY conversion).

Figure 10.20 shows a flowchart of the XY conversion.

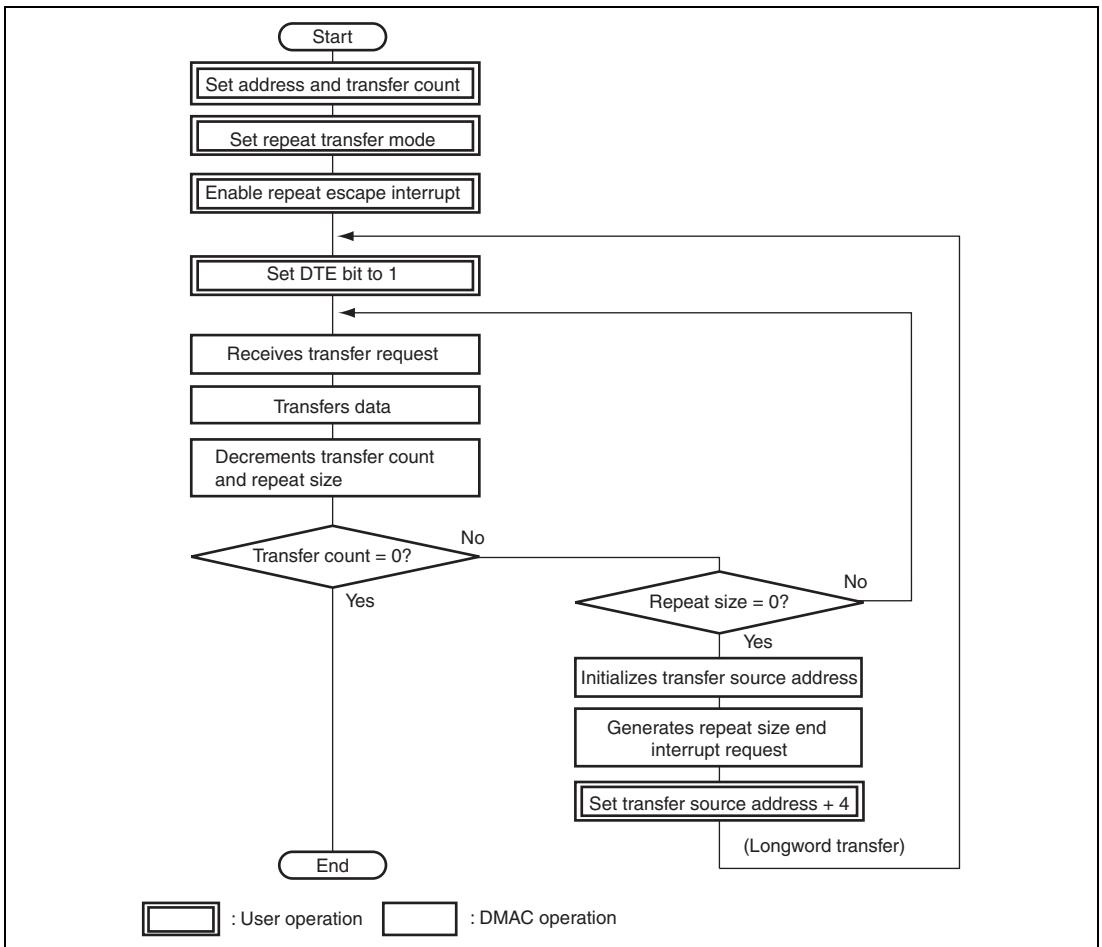

Figure 10.20 XY Conversion Flowchart Using Offset Addition in Repeat Transfer Mode

(3) Offset Subtraction

When setting the negative value in DOFR, the offset value must be 2's complement. The 2's complement is obtained by the following formula.

2's complement of offset = 1 + ~offset (~: bit inversion)

Example: 2's complement of H'0001FFFF
 = H'FFFE0000 + H'00000001
 = H'FFFE0001

The value of 2's complement can be obtained by the NEG.L instruction.

10.5.7 Register during DMA Transfer

The DMAC registers are updated by a DMA transfer. The value to be updated differs according to the other settings and transfer state. The registers to be updated are DSAR, DDAR, DTCR, bits BKSZH and BKSZ in DBSR, and the DTE, ACT, ERRF, ESIF, and DTIF bits in DMDR.

(1) DMA Source Address Register

When the transfer source address set in DSAR is accessed, the contents of DSAR are output and then are updated to the next address.

The increment or decrement can be specified by bits SAT1 and SAT0 in DACR. When SAT1 and SAT0 = B'00, the address is fixed. When SAT1 and SAT0 = B'01, the address is added with the offset. When SAT1 and SAT0 = B'10, the address is incremented. When SAT1 and SAT0 = B'11, the address is decremented. The size of increment or decrement depends on the data access size.

The data access size is specified by bits DTSZ1 and DTSZ0 in DMDR. When DTSZ1 and DTSZ0 = B'00, the data access size is byte and the address is incremented or decremented by 1. When DTSZ1 and DTSZ0 = B'01, the data access size is word and the address is incremented or decremented by 2. When DTSZ1 and DTSZ0 = B'10, the data access size is longword and the address is incremented or decremented by 4. Even if the access data size of the source address is word or longword, when the source address is not aligned with the word or longword boundary, the read bus cycle is divided into byte or word cycles. While data of one word or one longword is being read, the size of increment or decrement is changing according to the actual data access size, for example, +1 or +2 for byte or word data. After one word or one longword of data is read, the address when the read cycle is started is incremented or decremented by the value according to bits SAT1 and SAT0.

In block or repeat transfer mode, when the block or repeat size of data transfers is completed while the block or repeat area is specified to the source address side, the source address returns to the transfer start address and is not affected by the address update.

When the extended repeat area is specified to the source address side, operation follows the setting. The upper address bits are fixed and is not affected by the address update.

While data is being transferred, DSAR must be accessed in longwords. If the upper word and lower word are read separately, incorrect data may be read from since the contents of DSAR during the transfer may be updated regardless of the access by the CPU. Moreover, DSAR for the channel being transferred must not be written to.

(2) DMA Destination Address Register

When the transfer destination address set in DDAR is accessed, the contents of DDAR are output and then are updated to the next address.

The increment or decrement can be specified by bits DAT1 and DAT0 in DACR. When DAT1 and DAT0 = B'00, the address is fixed. When DAT1 and DAT0 = B'01, the address is added with the offset. When DAT1 and DAT0 = B'10, the address is incremented. When DAT1 and DAT0 = B'11, the address is decremented. The incrementing or decrementing size depends on the data access size.

The data access size is specified by bits DTSZ1 and DTSZ0 in DMDR. When DTSZ1 and DTSZ0 = B'00, the data access size is byte and the address is incremented or decremented by 1. When DTSZ1 and DTSZ0 = B'01, the data access size is word and the address is incremented or decremented by 2. When DTSZ1 and DTSZ0 = B'10, the data access size is longword and the address is incremented or decremented by 4. Even if the access data size of the destination address is word or longword, when the destination address is not aligned with the word or longword boundary, the write bus cycle is divided into byte and word cycles. While one word or one longword of data is being written, the incrementing or decrementing size is changing according to the actual data access size, for example, +1 or +2 for byte or word data. After the one word or one longword of data is written, the address when the write cycle is started is incremented or decremented by the value according to bits SAT1 and SAT0.

In block or repeat transfer mode, when the block or repeat size of data transfers is completed while the block or repeat area is specified to the destination address side, the destination address returns to the transfer start address and is not affected by the address update.

When the extended repeat area is specified to the destination address side, operation follows the setting. The upper address bits are fixed and is not affected by the address update.

While data is being transferred, DDAR must be accessed in longwords. If the upper word and lower word are read separately, incorrect data may be read from since the contents of DDAR during the transfer may be updated regardless of the access by the CPU. Moreover, DDAR for the channel being transferred must not be written to.

(3) DMA Transfer Count Register (DTCR)

A DMA transfer decrements the contents of DTCR by the transferred bytes. When byte data is transferred, DTCR is decremented by 1. When word data is transferred, DTCR is decremented by 2. When longword data is transferred, DTCR is decremented by 4. However, when DTCR = 0, the contents of DTCR are not changed since the number of transfers is not counted.

While data is being transferred, all the bits of DTCR may be changed. DTCR must be accessed in longwords. If the upper word and lower word are read separately, incorrect data may be read from since the contents of DTCR during the transfer may be updated regardless of the access by the CPU. Moreover, DTCR for the channel being transferred must not be written to.

When a conflict occurs between the address update by DMA transfer and write access by the CPU, the CPU has priority. When a conflict occurs between change from 1, 2, or 4 to 0 in DTCR and write access by the CPU (other than 0), the CPU has priority in writing to DTCR. However, the transfer is stopped.

(4) DMA Block Size Register (DBSR)

DBSR is enabled in block or repeat transfer mode. Bits 31 to 16 in DBSR function as BKSZH and bits 15 to 0 in DBSR function as BKSZ. The BKSZH bits (16 bits) store the block size and repeat size and its value is not changed. The BKSZ bits (16 bits) function as a counter for the block size and repeat size and its value is decremented every transfer by 1. When the BKSZ value is to change from 1 to 0 by a DMA transfer, 0 is not stored but the BKSZH value is loaded into the BKSZ bits.

Since the upper 16 bits of DBSR are not updated, DBSR can be accessed in words.

DBSR for the channel being transferred must not be written to.

(5) DTE Bit in DMDR

Although the DTE bit in DMDR enables or disables data transfer by the CPU write access, it is automatically cleared to 0 according to the DMA transfer state by the DMAC.

The conditions for clearing the DTE bit by the DMAC are as follows:

- When the total size of transfers is completed
- When a transfer is completed by a transfer size error interrupt
- When a transfer is completed by a repeat size end interrupt
- When a transfer is completed by an extended repeat area overflow interrupt
- When a transfer is stopped by an NMI interrupt
- When a transfer is stopped by an address error
- Reset state
- Hardware standby mode
- When a transfer is stopped by writing 0 to the DTE bit

Writing to the registers for the channels when the corresponding DTE bit is set to 1 is prohibited (except for the DTE bit). When changing the register settings after writing 0 to the DTE bit, confirm that the DTE bit has been cleared to 0.

Figure 10.21 show the procedure for changing the register settings for the channel being transferred.

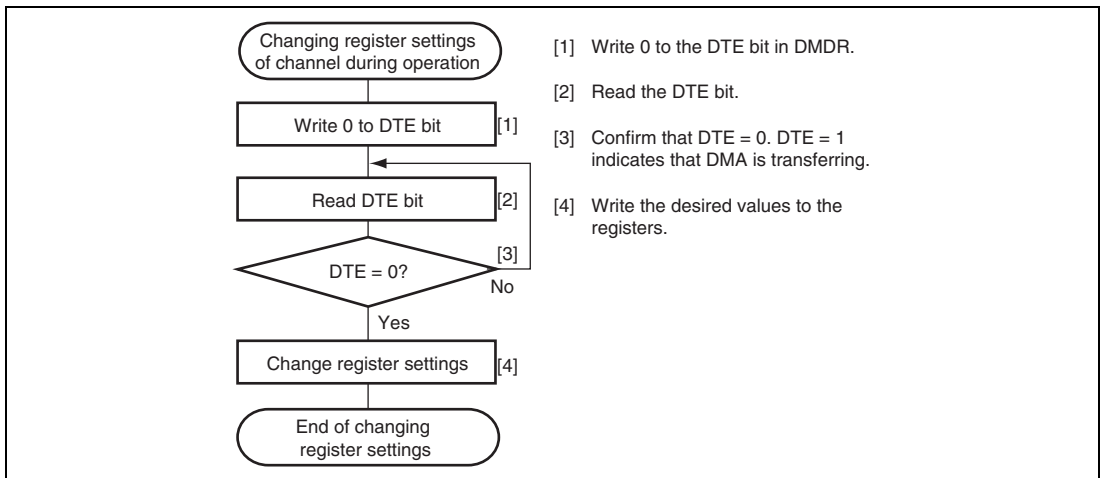

Figure 10.21 Procedure for Changing Register Setting For Channel being Transferred

(6) ACT Bit in DMDR

The ACT bit in DMDR indicates whether the DMAC is in the idle or active state. When DTE = 0 or DTE = 1 and the DMAC is waiting for a transfer request, the ACT bit is 0. Otherwise (the DMAC is in the active state), the ACT bit is 1. When individual transfers are stopped by writing 0 and the transfer is not completed, the ACT bit retains 1.

In block transfer mode, even if individual transfers are stopped by writing 0 to the DTE bit, the 1-block size of transfers is not stopped. The ACT bit retains 1 from writing 0 to the DTE bit to completion of a 1-block size transfer.

In burst mode, up to three times of DMA transfer are performed from the cycle in which the DTE bit is written to 0. The ACT bit retains 1 from writing 0 to the DTE bit to completion of DMA transfer.

(7) ERRF Bit in DMDR

When an address error or an NMI interrupt occur, the DMAC clears the DTE bits for all the channels to stop a transfer. In addition, it sets the ERRF bit in DMDR_0 to 1 to indicate that an address error or an NMI interrupt has occurred regardless of whether or not the DMAC is in operation.

However, when the DMAC is in the module stop state, the ERRF bit is not set to 1 for address errors or the NMI.

(8) ESIF Bit in DMDR

When an interrupt by a transfer size error, a repeat size end, or an extended repeat area overflow is requested, the ESIF bit in DMDR is set to 1. When both the ESIF and ESIE bits are set to 1, a transfer escape interrupt is requested to the CPU or DTC.

The ESIF bit is set to 1 when the ACT bit in DMDR is cleared to 0 to stop a transfer after the bus cycle of the interrupt source is completed.

The ESIF bit is automatically cleared to 0 and a transfer request is cleared if the transfer is resumed by setting the DTE bit to 1 during interrupt handling.

For details on interrupts, see section 10.8, Interrupt Sources.

(9) DTIF Bit in DMDR

The DTIF bit in DMDR is set to 1 after the total transfer size of transfers is completed. When both the DTIF and DTIE bits in DMDR are set to 1, a transfer end interrupt by the transfer counter is requested to the CPU or DTC.

The DTIF bit is set to 1 when the ACT bit in DMDR is cleared to 0 to stop a transfer after the bus cycle is completed.

The DTIF bit is automatically cleared to 0 and a transfer request is cleared if the transfer is resumed by setting the DTE bit to 1 during interrupt handling.

For details on interrupts, see section 10.8, Interrupt Sources.

10.5.8 Priority of Channels

The channels of the DMAC are given following priority levels: channel 0 > channel 1 > channel 2 > channel 3. Table 10.6 shows the priority levels among the DMAC channels.

Table 10.6 Priority among DMAC Channels

Channel	Priority
Channel 0	High
Channel 1	
Channel 2	
Channel 3	Low



The channel having highest priority other than the channel being transferred is selected when a transfer is requested from other channels. The selected channel starts the transfer after the channel being transferred releases the bus. At this time, when a bus master other than the DMAC requests the bus, the cycle for the bus master is inserted.

In a burst transfer or a block transfer, channels are not switched.

Figure 10.22 shows a transfer example when multiple transfer requests from channels 0 to 2.

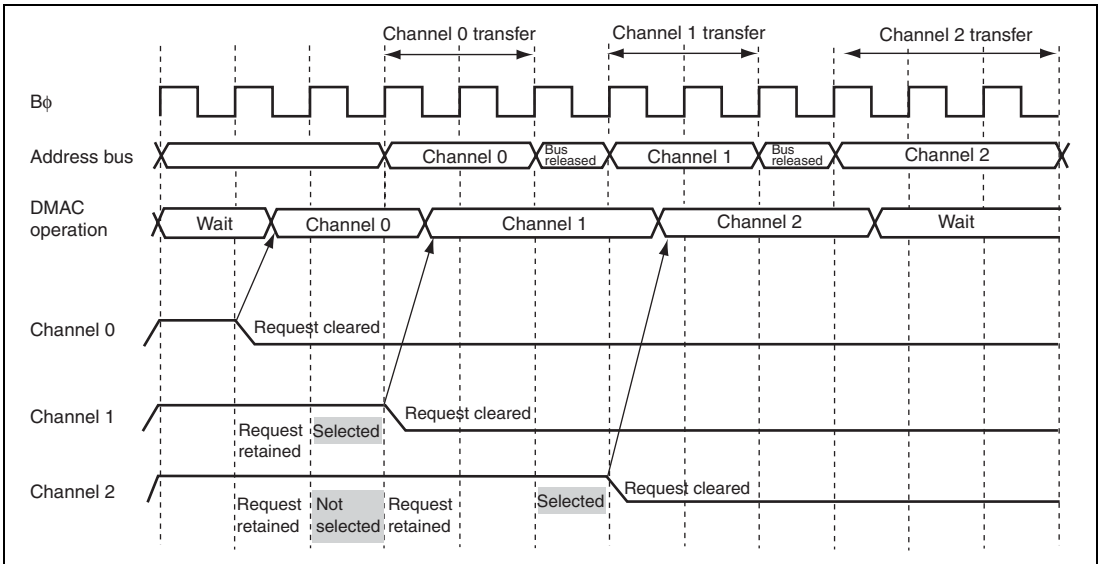

Figure 10.22 Example of Timing for Channel Priority

10.5.9 DMA Basic Bus Cycle

Figure 10.23 shows an examples of signal timing of a basic bus cycle. In Figure 10.23, data is transferred in words from the 16-bit 2-state access space to the 8-bit 3-state access space. When the bus mastership is passed from the DMAC to the CPU, data is read from the source address and it is written to the destination address. The bus is not released between the read and write cycles by other bus requests. DMAC bus cycles follows the bus controller settings.

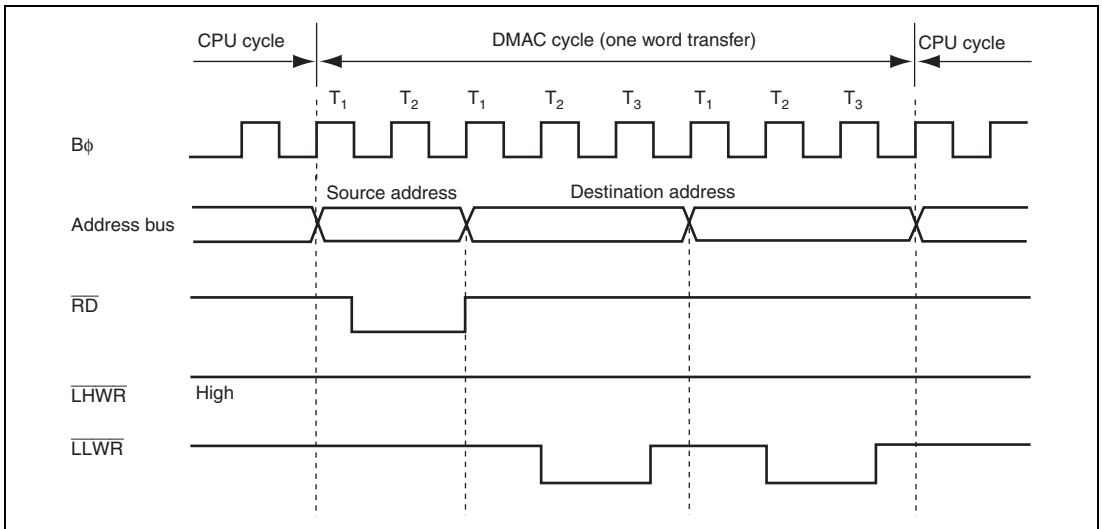

Figure 10.23 Example of Bus Timing of DMA Transfer

10.5.10 Bus Cycles in Dual Address Mode

(1) Normal Transfer Mode (Cycle Stealing Mode)

In cycle stealing mode, the bus is released every time one transfer size of data (one byte, one word, or one longword) is completed. One bus cycle or more by the CPU or DTC are executed in the bus released cycles.

In Figure 10.24, the $\overline{\text{TEND}}$ signal output is enabled and data is transferred in words from the external 16-bit 2-state access space to the external 16-bit 2-state access space in normal transfer mode by cycle stealing.

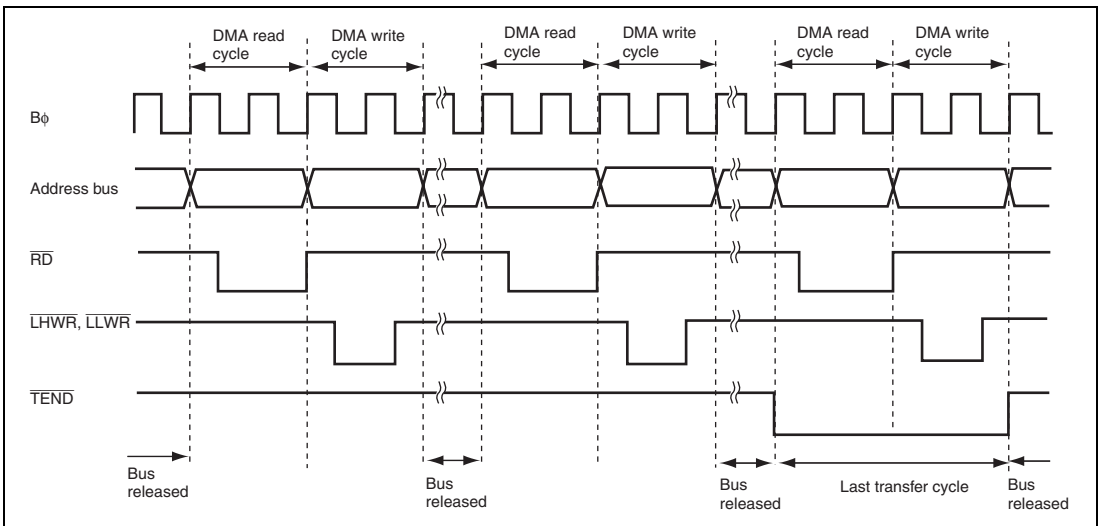

Figure 10.24 Example of Transfer in Normal Transfer Mode by Cycle Stealing

In figures 10.25 and 10.26, the $\overline{\text{TEND}}$ signal output is enabled and data is transferred in longwords from the external 16-bit 2-state access space to the 16-bit 2-state access space in normal transfer mode by cycle stealing.

In Figure 10.25, the transfer source (DSAR) is not aligned with a longword boundary and the transfer destination (DDAR) is aligned with a longword boundary.

In Figure 10.26, the transfer source (DSAR) is aligned with a longword boundary and the transfer destination (DDAR) is not aligned with a longword boundary.

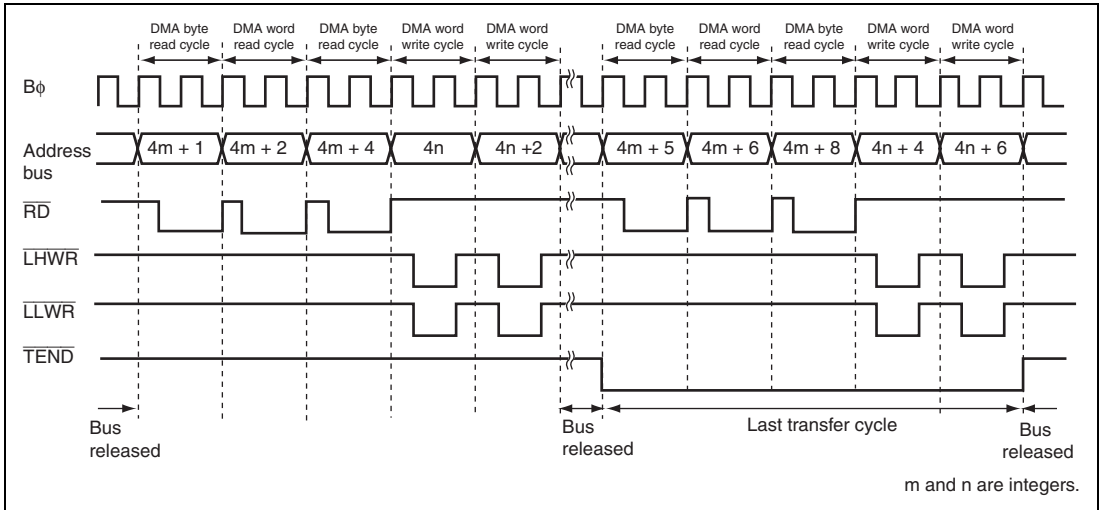

Figure 10.25 Example of Transfer in Normal Transfer Mode by Cycle Stealing (Transfer Source DSAR = Odd Address and Source Address Increment)

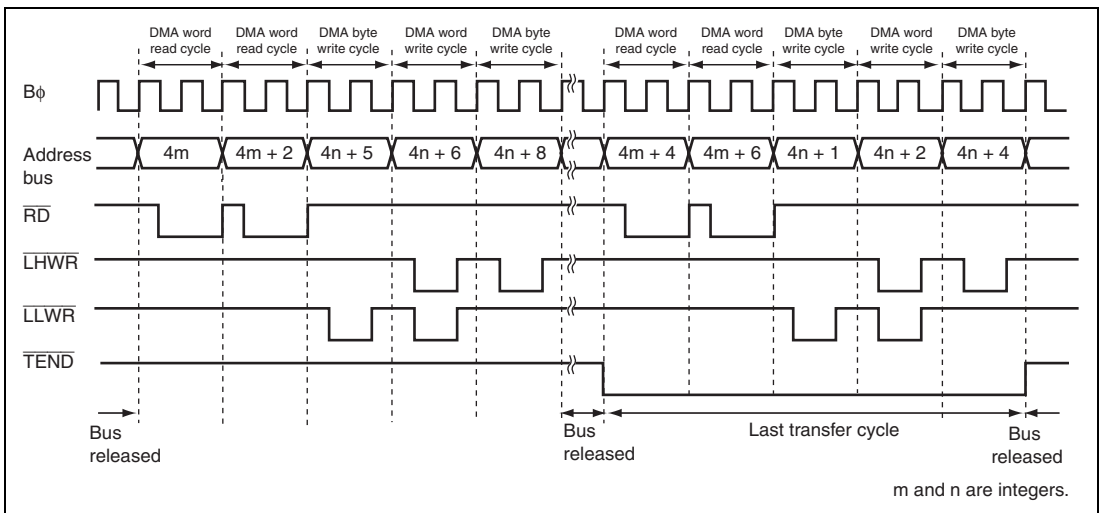

Figure 10.26 Example of Transfer in Normal Transfer Mode by Cycle Stealing (Transfer Destination DDAR = Odd Address and Destination Address Decrement)

(2) Normal Transfer Mode (Burst Mode)

In burst mode, one byte, one word, or one longword of data continues to be transferred until the transfer end condition is satisfied.

When a burst transfer starts, a transfer request from a channel having priority is suspended until the burst transfer is completed.

In Figure 10.27, the $\overline{\text{TEND}}$ signal output is enabled and data is transferred in words from the external 16-bit 2-state access space to the external 16-bit 2-state access space in normal transfer mode by burst access.

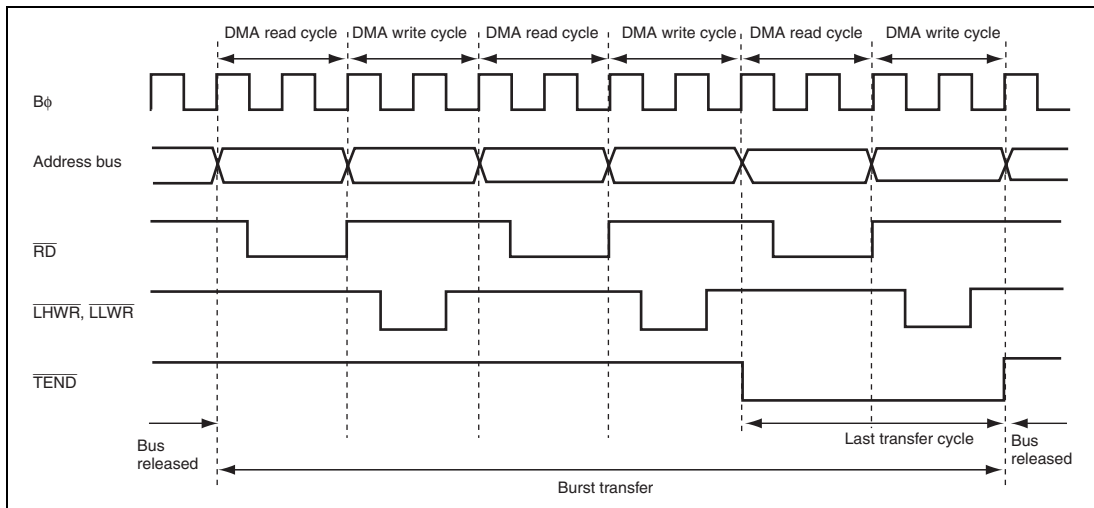

Figure 10.27 Example of Transfer in Normal Transfer Mode by Burst Access

(3) Block Transfer Mode

In block transfer mode, the bus is released every time a 1-block size of transfers at a single transfer request is completed.

In Figure 10.28, the $\overline{\text{TEND}}$ signal output is enabled and data is transferred in words from the external 16-bit 2-state access space to the external 16-bit 2-state access space in block transfer mode.

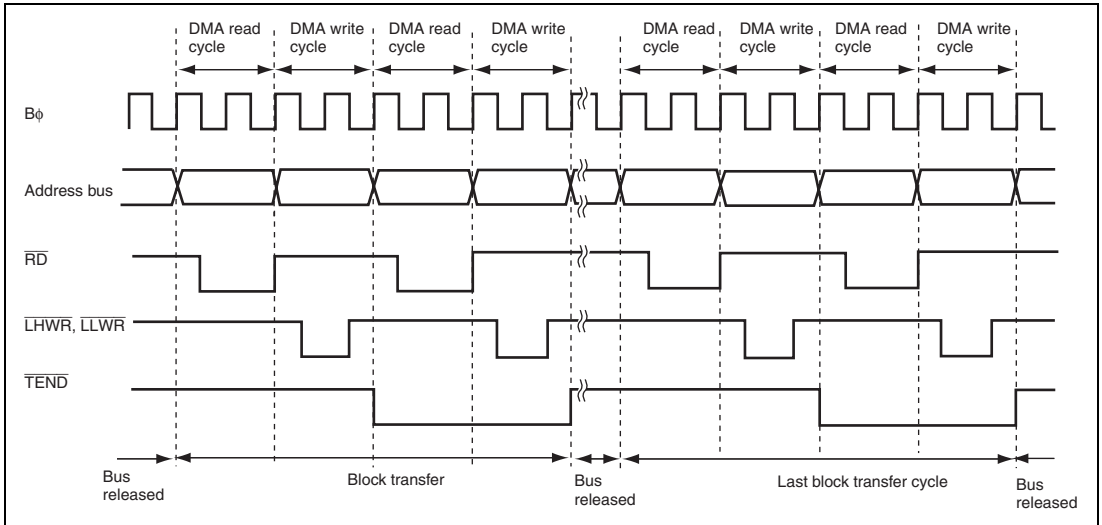

Figure 10.28 Example of Transfer in Block Transfer Mode

(4) Activation Timing by $\overline{\text{DREQ}}$ Falling Edge

Figure 10.29 shows an example of normal transfer mode activated by the $\overline{\text{DREQ}}$ signal falling edge.

The $\overline{\text{DREQ}}$ signal is sampled every cycle from the next rising edge of the $\text{B}\phi$ signal immediately after the DTE bit write cycle.

When a low level of the $\overline{\text{DREQ}}$ signal is detected while a transfer request by the $\overline{\text{DREQ}}$ signal is enabled, a transfer request is held in the DMAC. When the DMAC is activated, the transfer request is cleared and starts detecting a high level of the $\overline{\text{DREQ}}$ signal for falling edge detection. If a high level of the $\overline{\text{DREQ}}$ signal has been detected until completion of the DMA write cycle, receiving the next transfer request resumes and then a low level of the $\overline{\text{DREQ}}$ signal is detected. This operation is repeated until the transfer is completed.

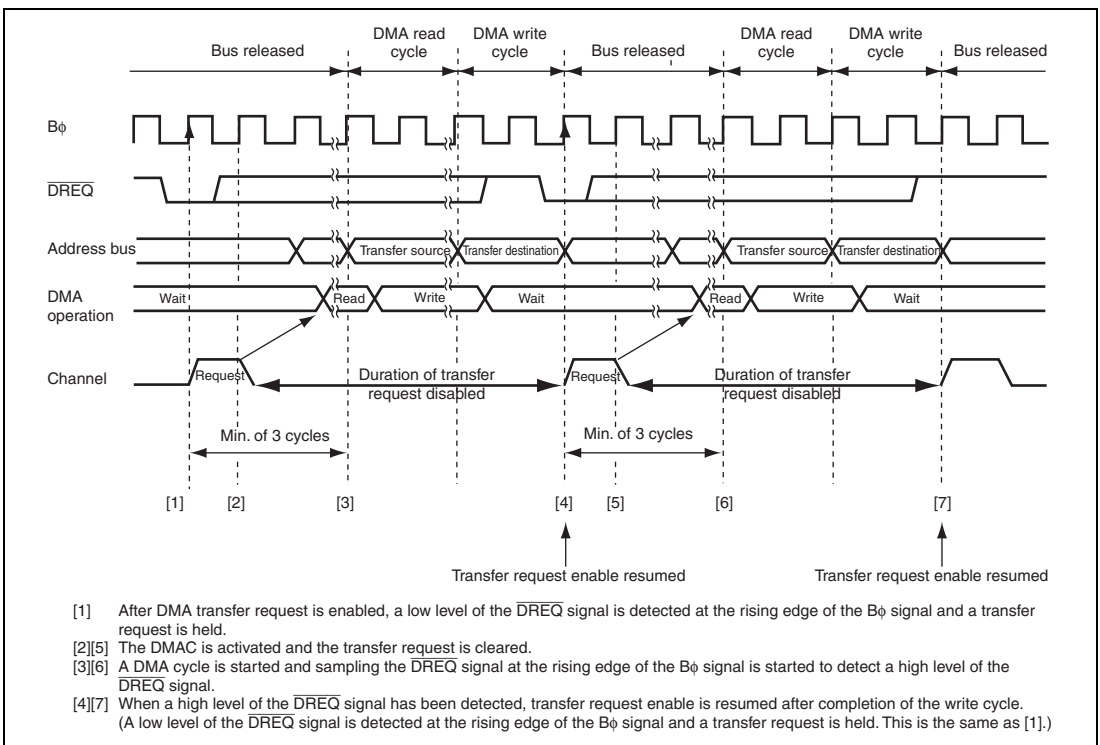

Figure 10.29 Example of Transfer in Normal Transfer Mode Activated by $\overline{\text{DREQ}}$ Falling Edge

Figure 10.30 shows an example of block transfer mode activated by the $\overline{\text{DREQ}}$ signal falling edge.

The $\overline{\text{DREQ}}$ signal is sampled every cycle from the next rising edge of the $\text{B}\phi$ signal immediately after the DTE bit write cycle.

When a low level of the $\overline{\text{DREQ}}$ signal is detected while a transfer request by the $\overline{\text{DREQ}}$ signal is enabled, a transfer request is held in the DMAC. When the DMAC is activated, the transfer request is cleared and starts detecting a high level of the $\overline{\text{DREQ}}$ signal for falling edge detection. If a high level of the $\overline{\text{DREQ}}$ signal has been detected until completion of the DMA write cycle, receiving the next transfer request resumes and then a low level of the $\overline{\text{DREQ}}$ signal is detected. This operation is repeated until the transfer is completed.

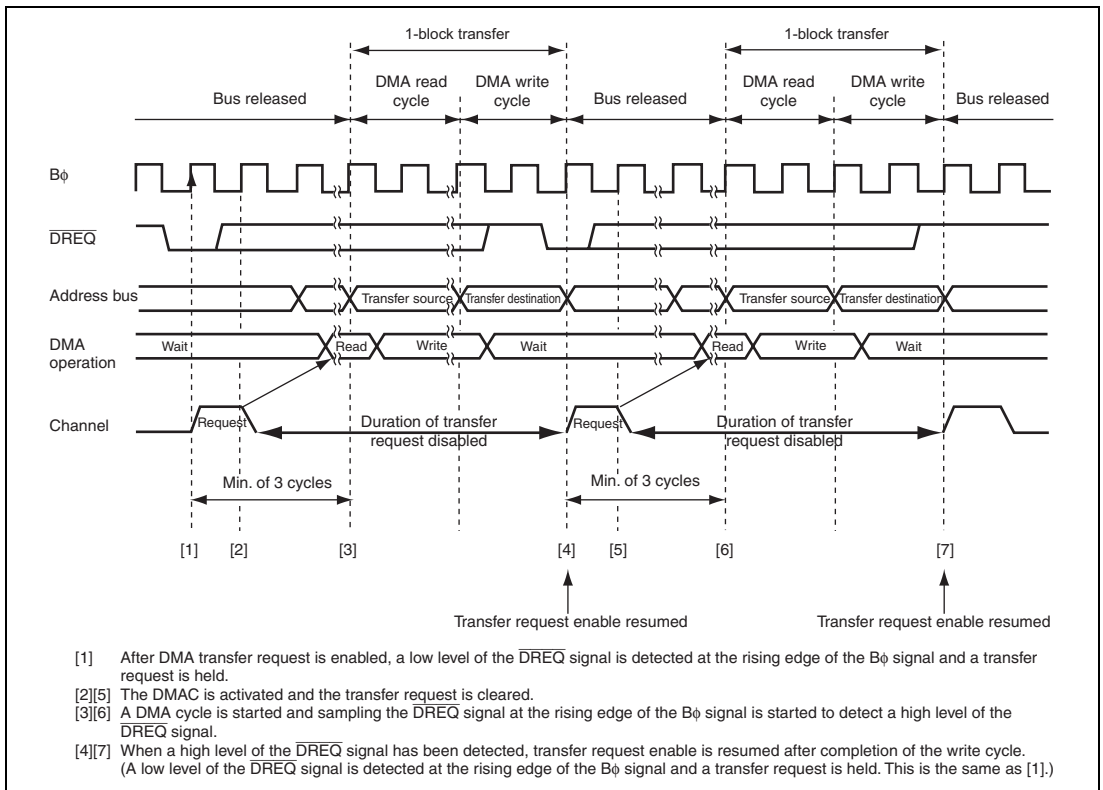

Figure 10.30 Example of Transfer in Block Transfer Mode Activated by $\overline{\text{DREQ}}$ Falling Edge

(5) Activation Timing by $\overline{\text{DREQ}}$ Low Level

Figure 10.31 shows an example of normal transfer mode activated by the $\overline{\text{DREQ}}$ signal low level.

The $\overline{\text{DREQ}}$ signal is sampled every cycle from the next rising edge of the $\text{B}\phi$ signal immediately after the DTE bit write cycle.

When a low level of the $\overline{\text{DREQ}}$ signal is detected while a transfer request by the $\overline{\text{DREQ}}$ signal is enabled, a transfer request is held in the DMAC. When the DMAC is activated, the transfer request is cleared. Receiving the next transfer request resumes after completion of the write cycle and then a low level of the $\overline{\text{DREQ}}$ signal is detected. This operation is repeated until the transfer is completed.

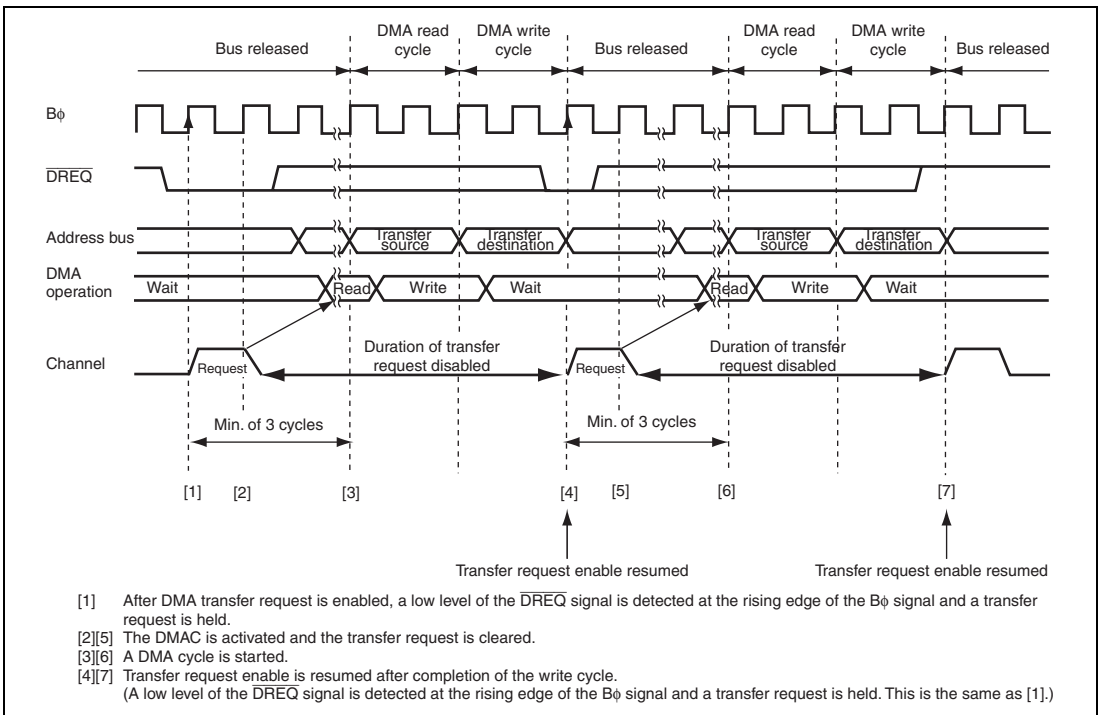

Figure 10.31 Example of Transfer in Normal Transfer Mode Activated by $\overline{\text{DREQ}}$ Low Level

Figure 10.32 shows an example of block transfer mode activated by the $\overline{\text{DREQ}}$ signal low level.

The $\overline{\text{DREQ}}$ signal is sampled every cycle from the next rising edge of the $\text{B}\phi$ signal immediately after the DTE bit write cycle.

When a low level of the $\overline{\text{DREQ}}$ signal is detected while a transfer request by the $\overline{\text{DREQ}}$ signal is enabled, a transfer request is held in the DMAC. When the DMAC is activated, the transfer request is cleared. Receiving the next transfer request resumes after completion of the write cycle and then a low level of the $\overline{\text{DREQ}}$ signal is detected. This operation is repeated until the transfer is completed.

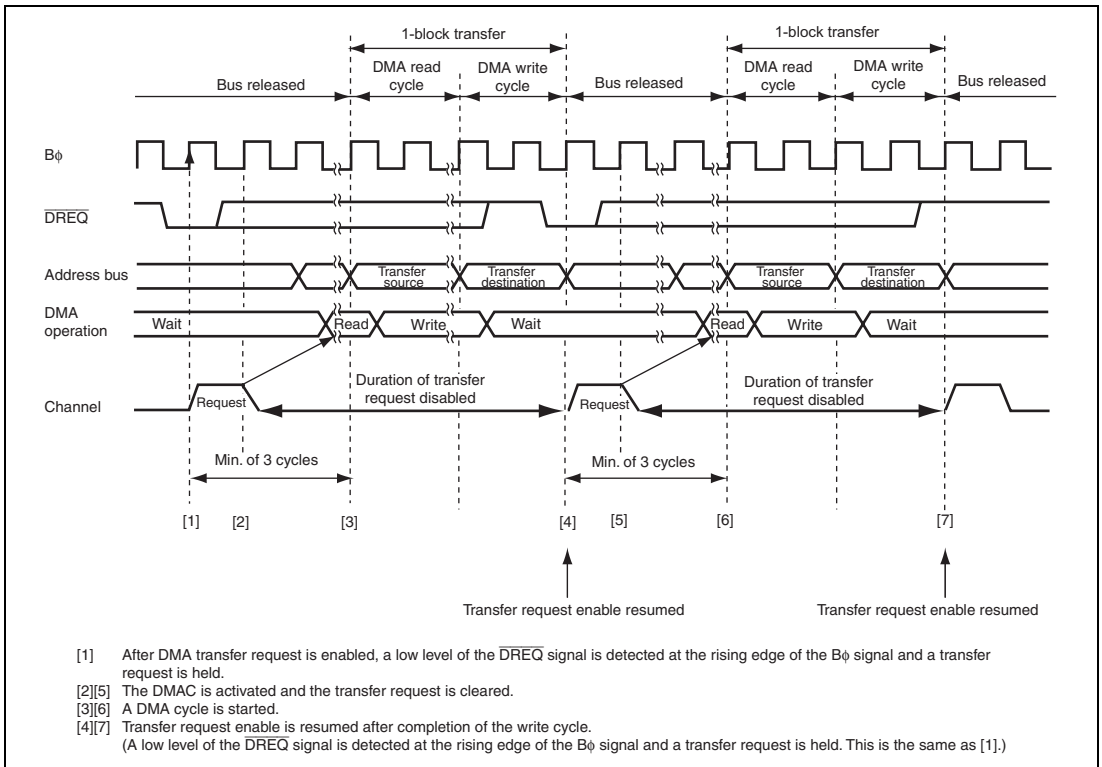

Figure 10.32 Example of Transfer in Block Transfer Mode Activated by $\overline{\text{DREQ}}$ Low Level

(6) Activation Timing by $\overline{\text{DREQ}}$ Low Level with $\text{NRD} = 1$

When the NRD bit in DMDR is set to 1, the timing of receiving the next transfer request is delayed for one cycle.

Figure 10.33 shows an example of normal transfer mode activated by the $\overline{\text{DREQ}}$ signal low level with $\text{NRD} = 1$.

The $\overline{\text{DREQ}}$ signal is sampled every cycle from the next rising edge of the $\text{B}\phi$ signal immediately after the DTE bit write cycle.

When a low level of the $\overline{\text{DREQ}}$ signal is detected while a transfer request by the $\overline{\text{DREQ}}$ signal is enabled, a transfer request is held in the DMAC. When the DMAC is activated, the transfer request is cleared. Receiving the next transfer request resumes after completion of the write cycle and then a low level of the $\overline{\text{DREQ}}$ signal is detected. This operation is repeated until the transfer is completed.

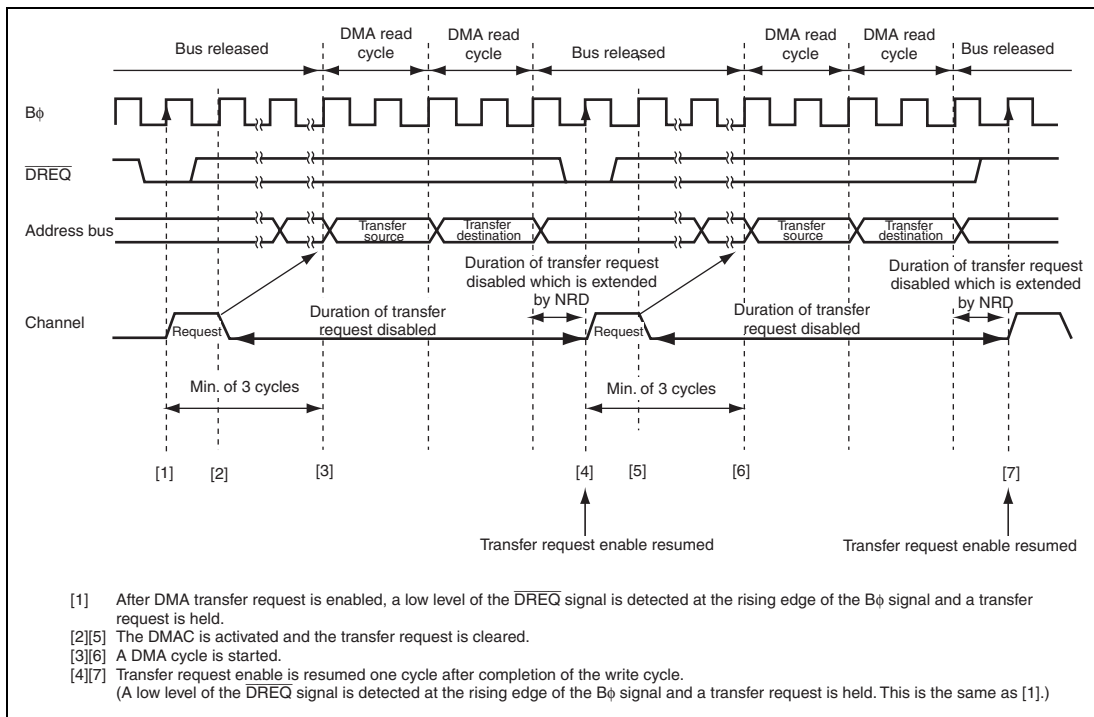

Figure 10.33 Example of Transfer in Normal Transfer Mode Activated by $\overline{\text{DREQ}}$ Low Level with $\text{NRD} = 1$

10.5.11 Bus Cycles in Single Address Mode

(1) Single Address Mode (Read and Cycle Stealing)

In single address mode, one byte, one word, or one longword of data is transferred at a single transfer request and after the transfer the bus is released temporarily. One bus cycle or more by the CPU or DTC are executed in the bus released cycles.

In Figure 10.34, the $\overline{\text{TEND}}$ signal output is enabled and data is transferred in bytes from the external 8-bit 2-state access space to the external device in single address mode (read).

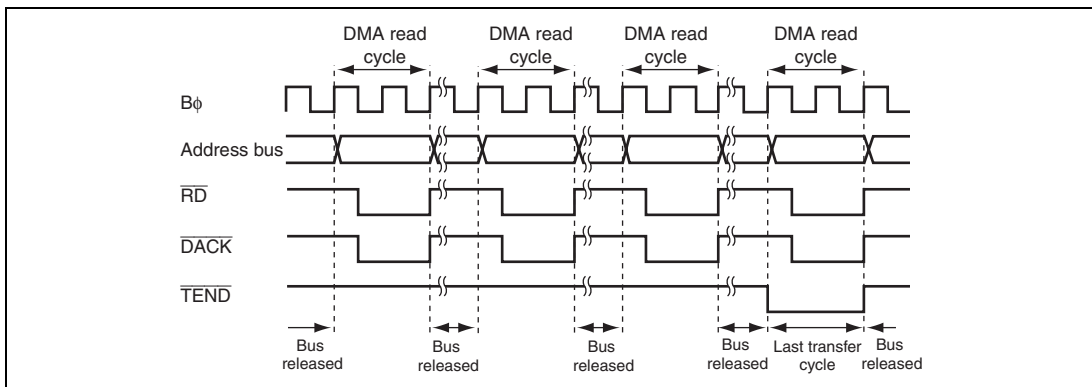

Figure 10.34 Example of Transfer in Single Address Mode (Byte Read)

(2) Single Address Mode (Write and Cycle Stealing)

In single address mode, data of one byte, one word, or one longword is transferred at a single transfer request and after the transfer the bus is released temporarily. One bus cycle or more by the CPU or DTC are executed in the bus released cycles.

In Figure 10.35, the $\overline{\text{TEND}}$ signal output is enabled and data is transferred in bytes from the external 8-bit 2-state access space to the external device in single address mode (write).

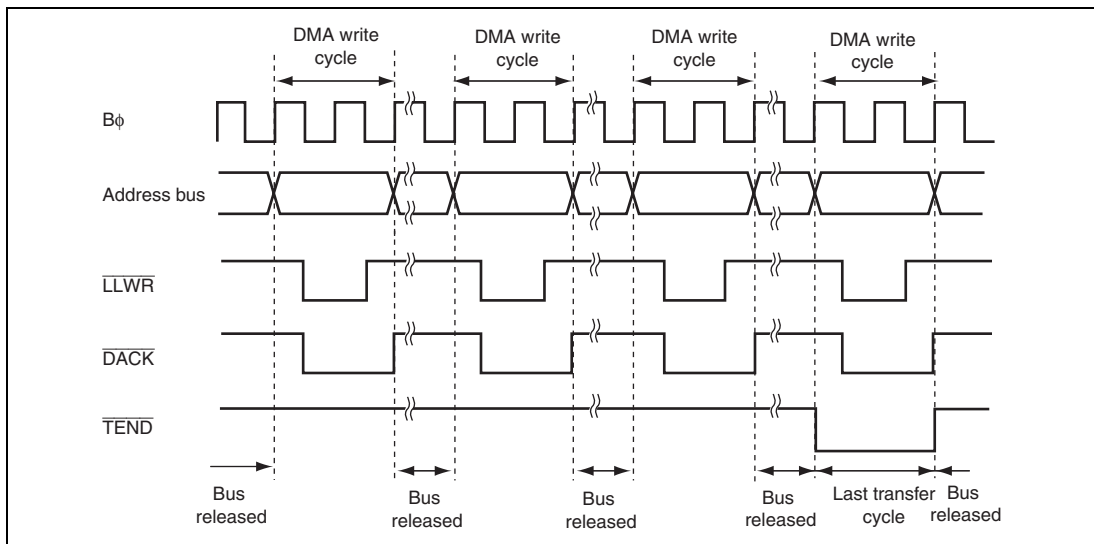

Figure 10.35 Example of Transfer in Single Address Mode (Byte Write)

(3) Activation Timing by $\overline{\text{DREQ}}$ Falling Edge

Figure 10.36 shows an example of single address mode activated by the $\overline{\text{DREQ}}$ signal falling edge.

The $\overline{\text{DREQ}}$ signal is sampled every cycle from the next rising edge of the $\text{B}\phi$ signal immediately after the DTE bit write cycle.

When a low level of the $\overline{\text{DREQ}}$ signal is detected while a transfer request by the $\overline{\text{DREQ}}$ signal is enabled, a transfer request is held in the DMAC. When the DMAC is activated, the transfer request is cleared and starts detecting a high level of the $\overline{\text{DREQ}}$ signal for falling edge detection. If a high level of the $\overline{\text{DREQ}}$ signal has been detected until completion of the single cycle, receiving the next transfer request resumes and then a low level of the $\overline{\text{DREQ}}$ signal is detected. This operation is repeated until the transfer is completed.

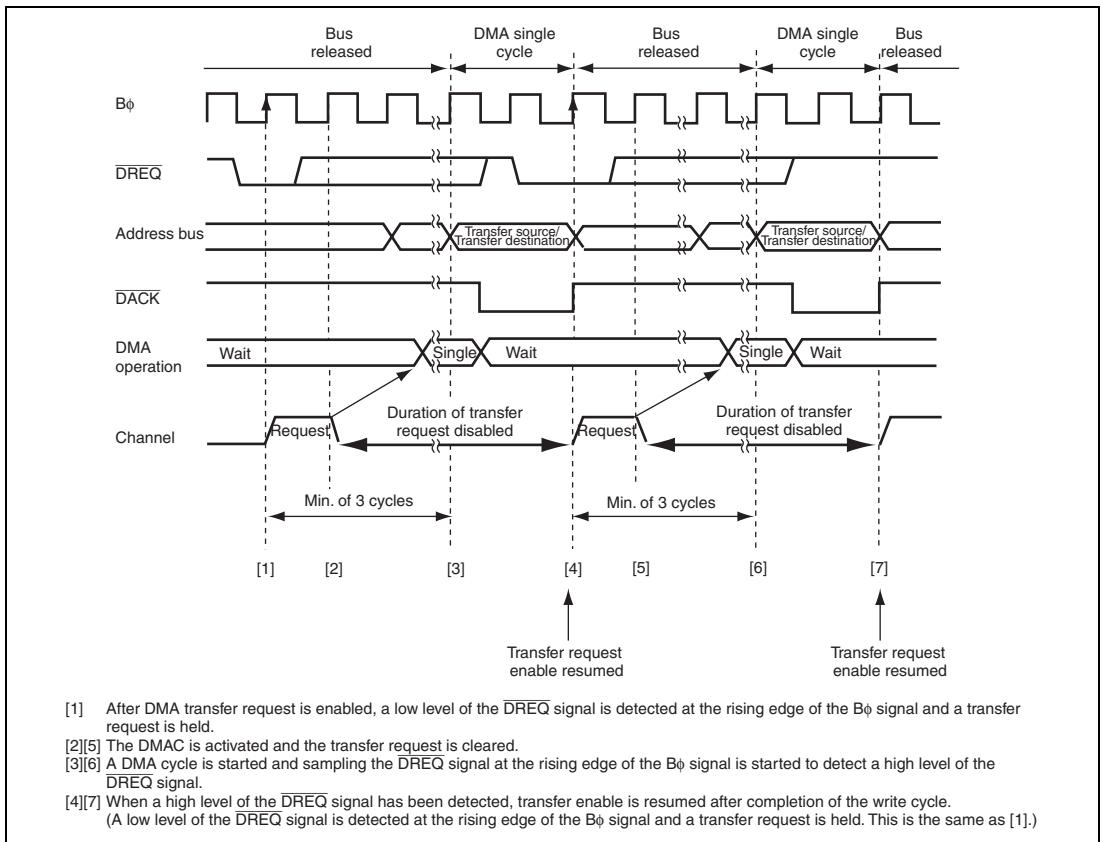

Figure 10.36 Example of Transfer in Single Address Mode Activated by $\overline{\text{DREQ}}$ Falling Edge

(4) Activation Timing by $\overline{\text{DREQ}}$ Low Level

Figure 10.37 shows an example of normal transfer mode activated by the $\overline{\text{DREQ}}$ signal low level.

The $\overline{\text{DREQ}}$ signal is sampled every cycle from the next rising edge of the $\text{B}\phi$ signal immediately after the DTE bit write cycle.

When a low level of the $\overline{\text{DREQ}}$ signal is detected while a transfer request by the $\overline{\text{DREQ}}$ signal is enabled, a transfer request is held in the DMAC. When the DMAC is activated, the transfer request is cleared. Receiving the next transfer request resumes after completion of the single cycle and then a low level of the $\overline{\text{DREQ}}$ signal is detected. This operation is repeated until the transfer is completed.

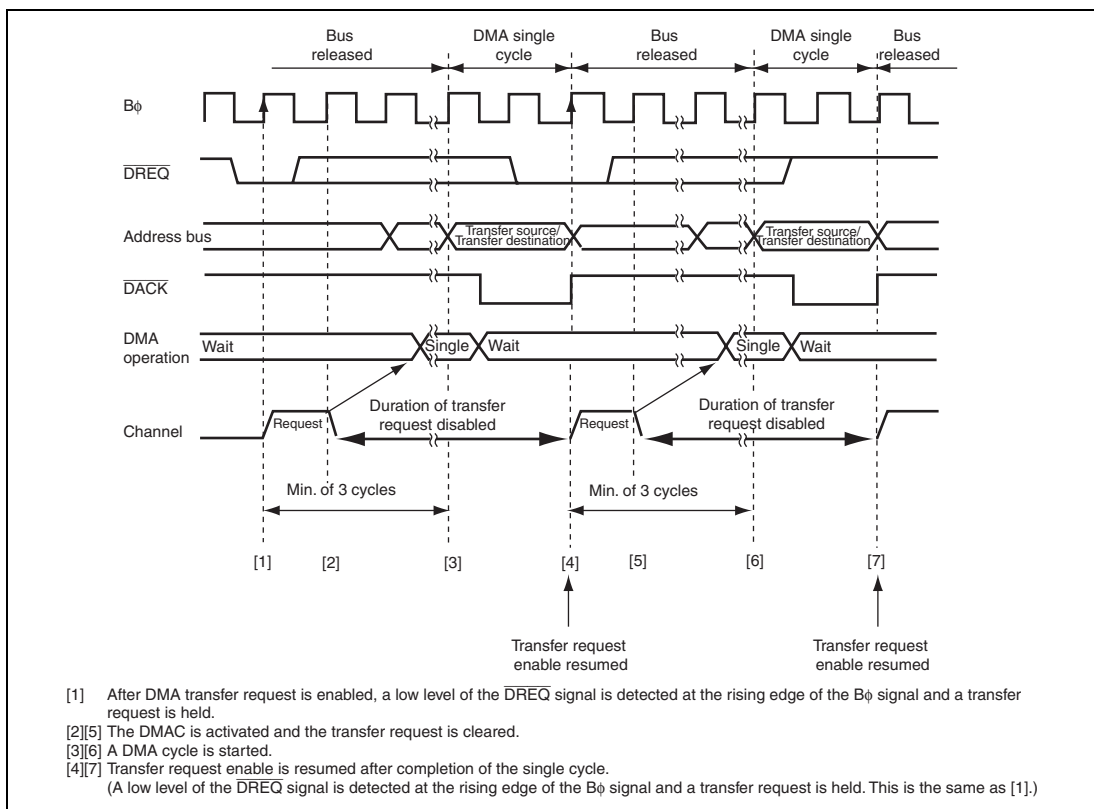

Figure 10.37 Example of Transfer in Single Address Mode Activated by $\overline{\text{DREQ}}$ Low Level

(5) Activation Timing by $\overline{\text{DREQ}}$ Low Level with $\text{NRD} = 1$

When the NRD bit in DMDR is set to 1, the timing of receiving the next transfer request is delayed for one cycle.

Figure 10.38 shows an example of single address mode activated by the $\overline{\text{DREQ}}$ signal low level with $\text{NRD} = 1$.

The $\overline{\text{DREQ}}$ signal is sampled every cycle from the next rising edge of the $\text{B}\phi$ signal immediately after the DTE bit write cycle.

When a low level of the $\overline{\text{DREQ}}$ signal is detected while a transfer request by the $\overline{\text{DREQ}}$ signal is enabled, a transfer request is held in the DMAC . When the DMAC is activated, the transfer request is cleared. Receiving the next transfer request resumes after one cycle of the transfer request duration inserted by $\text{NRD} = 1$ on completion of the single cycle and then a low level of the $\overline{\text{DREQ}}$ signal is detected. This operation is repeated until the transfer is completed.

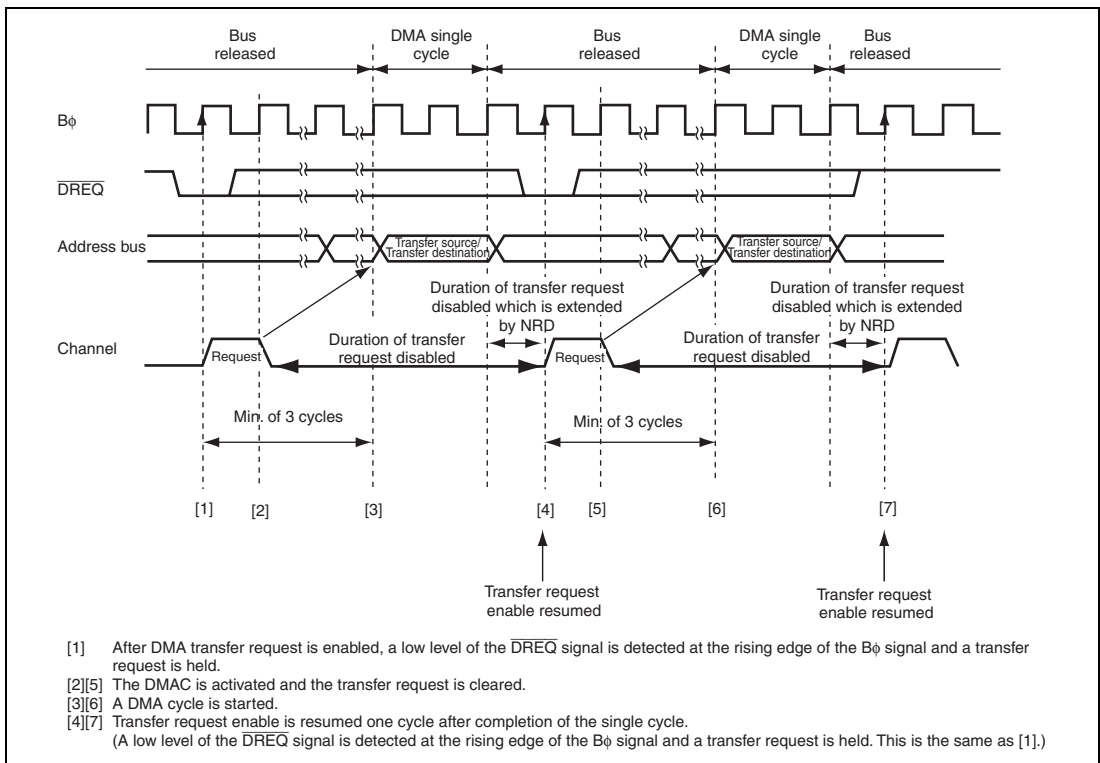

Figure 10.38 Example of Transfer in Single Address Mode Activated by $\overline{\text{DREQ}}$ Low Level with $\text{NRD} = 1$

10.6 DMA Transfer End

Operations on completion of a transfer differ according to the transfer end condition. DMA transfer completion is indicated that the DTE and ACT bits in DMDR are changed from 1 to 0.

(1) Transfer End by DTCR Change from 1, 2, or 4, to 0

When DTCR is changed from 1, 2, or 4 to 0, a DMA transfer for the channel is completed. The DTE bit in DMDR is cleared to 0 and the DTIF bit in DMDR is set to 1. At this time, when the DTIE bit in DMDR is set to 1, a transfer end interrupt by the transfer counter is requested. When the DTCR value is 0 before the transfer, the transfer is not stopped.

(2) Transfer End by Transfer Size Error Interrupt

When the following conditions are satisfied while the TSEIE bit in DMDR is set to 1, a transfer size error occurs and a DMA transfer is terminated. At this time, the DTE bit in DMDR is cleared to 0 and the ESIF bit in DMDR is set to 1.

- In normal transfer mode and repeat transfer mode, when the next transfer is requested while a transfer is disabled due to the DTCR value less than the data access size
- In block transfer mode, when the next transfer is requested while a transfer is disabled due to the DTCR value less than the block size

When the TSEIE bit in DMDR is cleared to 0, data is transferred until the DTCR value reaches 0. A transfer size error is not generated. Operation in each transfer mode is shown below.

- In normal transfer mode and repeat transfer mode, when the DTCR value is less than the data access size, data is transferred in bytes
- In block transfer mode, when the DTCR value is less than the block size, the specified size of data in DTCR is transferred instead of transferring the block size of data. The transfer is performed in bytes.

(3) Transfer End by Repeat Size End Interrupt

In repeat transfer mode, when the next transfer is requested after completion of a 1-repeat size data transfer while the RPTIE bit in DACR is set to 1, a repeat size end interrupt is requested. When the interrupt is requested to complete DMA transfer, the DTE bit in DMDR is cleared to 0 and the ESIF bit in DMDR is set to 1. Under this condition, setting the DTE bit to 1 resumes the transfer.

In block transfer mode, when the next transfer is requested after completion of a 1-block size data transfer, a repeat size end interrupt can be requested.

(4) Transfer End by Interrupt on Extended Repeat Area Overflow

When an overflow on the extended repeat area occurs while the extended repeat area is specified and the SARIE or DARIE bit in DACR is set to 1, an interrupt by an extended repeat area overflow is requested. When the interrupt is requested, the DMA transfer is terminated, the DTE bit in DMDR is cleared to 0, and the ESIF bit in DMDR is set to 1.

In dual address mode, even if an interrupt by an extended repeat area overflow occurs during a read cycle, the following write cycle is performed.

In block transfer mode, even if an interrupt by an extended repeat area overflow occurs during a 1-block transfer, the remaining data is transferred. The transfer is not terminated by an extended repeat area overflow interrupt unless the current transfer is complete.

(5) Transfer End by Clearing DTE Bit in DMDR

When the DTE bit in DMDR is cleared to 0 by the CPU, a transfer is completed after the current DMA cycle and a DMA cycle in which the transfer request is accepted are completed.

In block transfer mode, a DMA transfer is completed after 1-block data is transferred.

(6) Transfer End by NMI Interrupt

When an NMI interrupt is requested, the DTE bits for all the channels are cleared to 0 and the ERRF bit in DMDR_0 is set to 1. When an NMI interrupt is requested during a DMA transfer, the transfer is forced to stop. To perform DMA transfer after an NMI interrupt is requested, clear the ERRF bit to 0 and then set the DTE bits for the channels to 1.

The transfer end timings after an NMI interrupt is requested are shown below.

(a) Normal Transfer Mode and Repeat Transfer Mode

In dual address mode, a DMA transfer is completed after completion of the write cycle for one transfer unit.

In single address mode, a DMA transfer is completed after completion of the bus cycle for one transfer unit.

(b) Block Transfer Mode

A DMA transfer is forced to stop. Since a 1-block size of transfers is not completed, operation is not guaranteed.

In dual address mode, the write cycle corresponding to the read cycle is performed. This is similar to (a) in normal transfer mode.

(7) Transfer End by Address Error

When an address error occurs, the DTE bits for all the channels are cleared to 0 and the ERRF bit in DMDR_0 is set to 1. When an address error occurs during a DMA transfer, the transfer is forced to stop. To perform a DMA transfer after an address error occurs, clear the ERRF bit to 0 and then set the DTE bits for the channels.

The transfer end timing after an address error is the same as that after an NMI interrupt.

(8) Transfer End by Hardware Standby Mode or Reset

The DMAC is initialized by a reset and a transition to the hardware standby mode. A DMA transfer is not guaranteed.

10.7 Relationship among DMAC and Other Bus Masters

10.7.1 CPU Priority Control Function Over DMAC

The CPU priority control function over DMAC can be used according to the CPU priority control register (CPUPCR) setting. For details, see section 7.7, CPU Priority Control Function Over DTC and DMAC.

The priority level of the DMAC is specified by bits DMAP2 to DMAP0 and can be specified for each channel.

The priority level of the CPU is specified by bits CPUP2 to CPUP0. The value of bits CPUP2 to CPUP0 is updated according to the exception handling priority.

If the CPU priority control is enabled by the CPUPCE bit in CPUPCR, when the CPU has priority over the DMAC, a transfer request for the corresponding channel is masked and the transfer is not activated. When another channel has priority over or the same as the CPU, a transfer request is received regardless of the priority between channels and the transfer is activated.

The transfer request masked by the CPU priority control function is suspended. When the transfer channel is given priority over the CPU by changing priority levels of the CPU or channel, the transfer request is received and the transfer is resumed. Writing 0 to the DTE bit clears the suspended transfer request.

When the CPUPCE bit is cleared to 0, it is regarded as the lowest priority.

10.7.2 Bus Arbitration among DMAC and Other Bus Masters

When DMA transfer cycles are consecutively performed, bus cycles of other bus masters may be inserted between the transfer cycles. The DMAC can release the bus temporarily to pass the bus to other bus masters.

The consecutive DMA transfer cycles may not be divided according to the transfer mode settings to achieve high-speed access.

The read and write cycles of a DMA transfer are not separated. Refreshing, external bus release, and on-chip bus master (CPU or DTC) cycles are not inserted between the read and write cycles of a DMA transfer.

In block transfer mode and an auto request transfer by burst access, bus cycles of the DMA transfer are consecutively performed. For this duration, since the DMAC has priority over the CPU and DTC, accesses to the external space is suspended (the IBCCS bit in the bus control register 2 (BCR2) is cleared to 0).

When the bus is passed to another channel or an auto request transfer by cycle stealing, bus cycles of the DMAC and on-chip bus master are performed alternatively.

When the arbitration function among the DMAC and on-chip bus masters is enabled by setting the IBCCS bit in BCR2, the bus is used alternatively except the bus cycles which are not separated. For details, see section 9, Bus Controller (BSC).

A conflict may occur between external space access of the DMAC and an external bus release cycle. Even if a burst or block transfer is performed by the DMAC, the transfer is stopped temporarily and a cycle of external bus release is inserted by the BSC according to the external bus priority (when the CPU external access and the DTC external access do not have priority over a DMAC transfer, the transfers are not operated until the DMAC releases the bus).

In dual address mode, the DMAC releases the external bus after the external space write cycle. Since the read and write cycles are not separated, the bus is not released.

An internal space (on-chip memory and internal I/O registers) access of the DMAC and an external bus release cycle may be performed at the same time.

10.8 Interrupt Sources

The DMAC interrupt sources are a transfer end interrupt by the transfer counter and a transfer escape end interrupt which is generated when a transfer is terminated before the transfer counter reaches 0. Table 10.7 shows interrupt sources and priority.

Table 10.7 Interrupt Sources and Priority

Abbr.	Interrupt Sources	Priority
DMTEND0	Transfer end interrupt by channel 0 transfer counter	High  Low
DMTEND1	Transfer end interrupt by channel 1 transfer counter	
DMTEND2	Transfer end interrupt by channel 2 transfer counter	
DMTEND3	Transfer end interrupt by channel 3 transfer counter	
DMEEND0	Interrupt by channel 0 transfer size error	
	Interrupt by channel 0 repeat size end	
	Interrupt by channel 0 extended repeat area overflow on source address	
	Interrupt by channel 0 extended repeat area overflow on destination address	
DMEEND1	Interrupt by channel 1 transfer size error	
	Interrupt by channel 1 repeat size end	
	Interrupt by channel 1 extended repeat area overflow on source address	
	Interrupt by channel 1 extended repeat area overflow on destination address	
DMEEND2	Interrupt by channel 2 transfer size error	
	Interrupt by channel 2 repeat size end	
	Interrupt by channel 2 extended repeat area overflow on source address	
	Interrupt by channel 2 extended repeat area overflow on destination address	
DMEEND3	Interrupt by channel 3 transfer size error	
	Interrupt by channel 3 repeat size end	
	Interrupt by channel 3 extended repeat area overflow on source address	
	Interrupt by channel 3 extended repeat area overflow on destination address	

Each interrupt is enabled or disabled by the DTIE and ESIE bits in DMDR for the corresponding channel. A DMTEND interrupt is generated by the combination of the DTIF and DTIE bits in DMDR. A DMEEND interrupt is generated by the combination of the ESIF and ESIE bits in DMDR. The DMEEND interrupt sources are not distinguished. The priority among channels are decided by the interrupt controller and it is shown in Table 10.7. For details, see section 7, Interrupt Controller.

Each interrupt source is specified by the interrupt enable bit in the register for the corresponding channel. A transfer end interrupt by the transfer counter, a transfer size error interrupt, a repeat size end interrupt, an interrupt by an extended repeat area overflow on the source address, and an interrupt by an extended repeat area overflow on the destination address are enabled or disabled by the DTIE bit in DMDR, the TSEIE bit in DMDR, the RPTIE bit in DACR, SARIE bit in DACR, and the DARIE bit in DACR, respectively.

A transfer end interrupt by the transfer counter is generated when the DTIF bit in DMDR is set to 1. The DTIF bit is set to 1 when DTCR becomes 0 by a transfer while the DTIE bit in DMDR is set to 1.

An interrupt other than the transfer end interrupt by the transfer counter is generated when the ESIF bit in DMDR is set to 1. The ESIF bit is set to 1 when the conditions are satisfied by a transfer while the enable bit is set to 1.

A transfer size error interrupt is generated when the next transfer cannot be performed because the DTCR value is less than the data access size, meaning that the data access size of transfers cannot be performed. In block transfer mode, the block size is compared with the DTCR value for transfer error decision.

A repeat size end interrupt is generated when the next transfer is requested after completion of the repeat size of transfers in repeat transfer mode. Even when the repeat area is not specified in the address register, the transfer can be stopped periodically according to the repeat size. At this time, when a transfer end interrupt by the transfer counter is generated, the ESIF bit is set to 1.

An interrupt by an extended repeat area overflow on the source and destination addresses is generated when the address exceeds the extended repeat area (overflow). At this time, when a transfer end interrupt by the transfer counter, the ESIF bit is set to 1.

Figure 10.39 is a block diagram of interrupts and interrupt flags. To clear an interrupt, clear the DTIF or ESIF bit in DMDR to 0 in the interrupt handling routine or continue the transfer by setting the DTE bit in DMDR after setting the register. Figure 10.40 shows procedure to resume the transfer by clearing an interrupt.

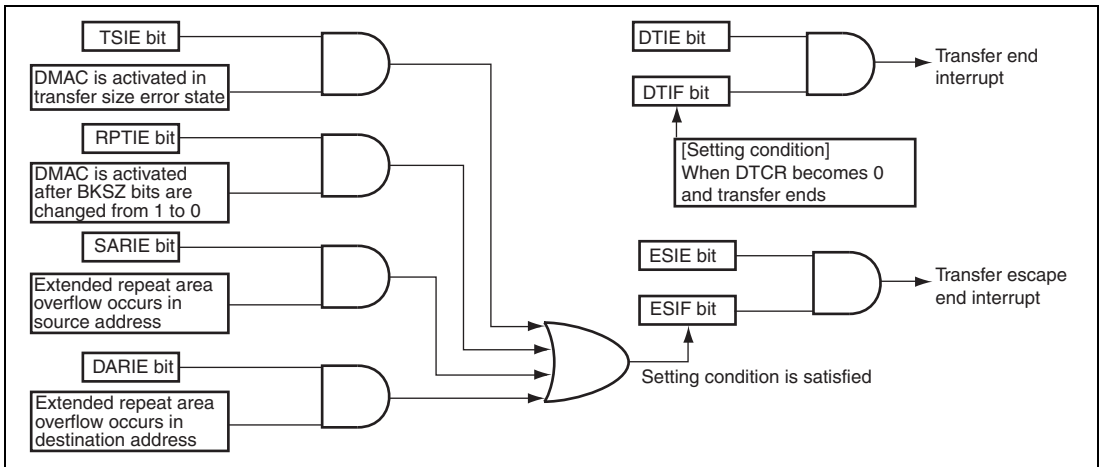

Figure 10.39 Interrupt and Interrupt Sources

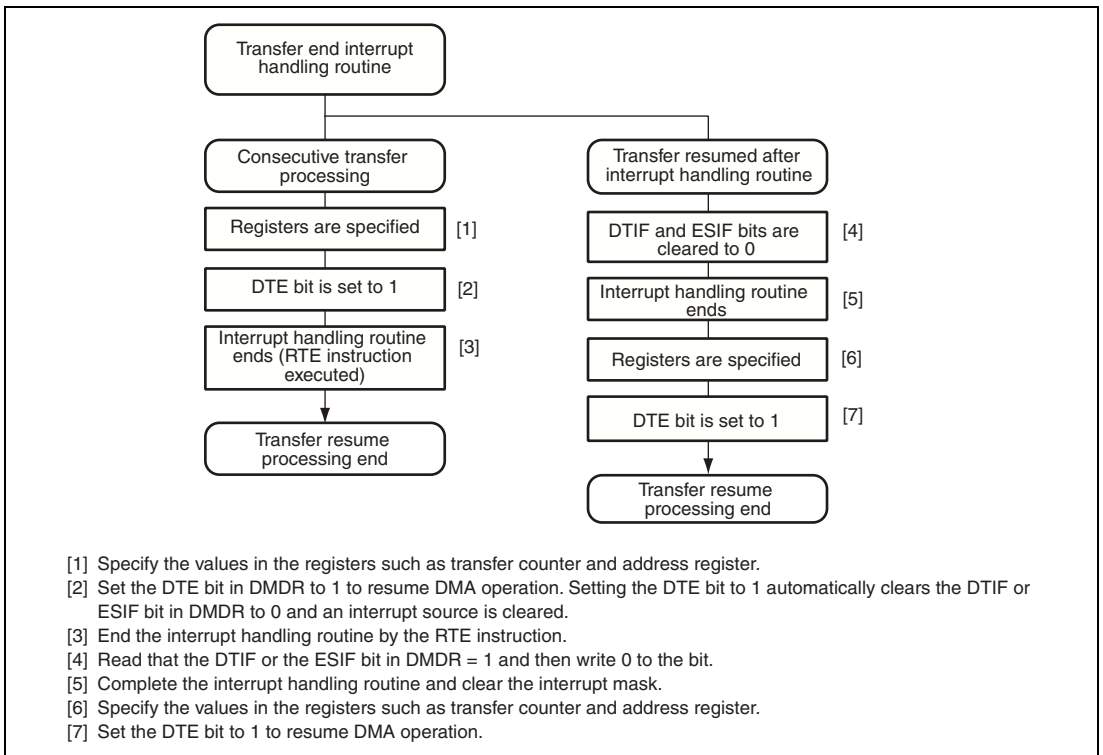

Figure 10.40 Procedure Example of Resuming Transfer by Clearing Interrupt Source

10.9 Usage Notes

1. DMAC Register Access During Operation

Except for clearing the DTE bit in DMDR, the settings for channels being transferred (including waiting state) must not be changed. The register settings must be changed during the transfer prohibited state.

2. Settings of Module Stop Function

The DMAC operation can be enabled or disabled by the module stop control register. The DMAC is enabled by the initial value.

Setting bit MSTPA13 in MSTPCRA stops the clock supplied to the DMAC and the DMAC enters the module stop state. However, when a transfer for a channel is enabled or when an interrupt is being requested, bit MSTPA13 cannot be set to 1. Clear the DTE bit to 0, clear the DTIF or DTIE bit in DMDR to 0, and then set bit MSTPA13.

When the clock is stopped, the DMAC registers cannot be accessed. However, the following register settings are valid in the module stop state. Disable them before entering the module stop state, if necessary.

— TENDE bit in DMDR is 1 (the \overline{TEND} signal output enabled)

— DACKE bit in DMDR is 1 (the \overline{DACK} signal output enabled)

3. Activation by \overline{DREQ} Falling Edge

The \overline{DREQ} falling edge detection is synchronized with the DMAC internal operation.

A. Activation request waiting state: Waiting for detecting the \overline{DREQ} low level. A transition to 2. is made.

B. Transfer waiting state: Waiting for a DMAC transfer. A transition to 3. is made.

C. Transfer prohibited state: Waiting for detecting the \overline{DREQ} high level. A transition to 1. is made.

After a DMAC transfer enabled, a transition to 1. is made. Therefore, the \overline{DREQ} signal is sampled by low level detection at the first activation after a DMAC transfer enabled.

4. Acceptation of Activation Source

At the beginning of an activation source reception, a low level is detected regardless of the setting of \overline{DREQ} falling edge or low level detection. Therefore, if the \overline{DREQ} signal is driven low before setting DMDR, the low level is received as a transfer request.

When the DMAC is activated, clear the \overline{DREQ} signal of the previous transfer.

Section 11 Data Transfer Controller (DTC)

This LSI includes a data transfer controller (DTC). The DTC can be activated to transfer data by an interrupt request.

11.1 Features

- Transfer possible over any number of channels:
 - Multiple data transfer enabled for one activation source (chain transfer)
 - Chain transfer specifiable after data transfer (when the counter is 0)
- Three transfer modes
 - Normal/repeat/block transfer modes selectable
 - Transfer source and destination addresses can be selected from increment/decrement/fixed
- Short address mode or full address mode selectable
 - Short address mode
 - Transfer information is located on a 3-longword boundary
 - The transfer source and destination addresses can be specified by 24 bits to select a 16-Mbyte address space directly
 - Full address mode
 - Transfer information is located on a 4-longword boundary
 - The transfer source and destination addresses can be specified by 32 bits to select a 4-Gbyte address space directly
- Size of data for data transfer can be specified as byte, word, or longword
 - The bus cycle is divided if an odd address is specified for a word or longword transfer.
 - The bus cycle is divided if address $4n + 2$ is specified for a longword transfer.
- A CPU interrupt can be requested for the interrupt that activated the DTC
 - A CPU interrupt can be requested after one data transfer completion
 - A CPU interrupt can be requested after the specified data transfer completion
- Read skip of the transfer information specifiable
- Writeback skip executed for the fixed transfer source and destination addresses
- Module stop state specifiable

Figure 11.1 shows a block diagram of the DTC. The DTC transfer information can be allocated to the data area*. When the transfer information is allocated to the on-chip RAM, a 32-bit bus connects the DTC to the on-chip RAM, enabling 32-bit/1-state reading and writing of the DTC transfer information.

Note: * When the transfer information is stored in the on-chip RAM, the RAME bit in SYSCR must be set to 1.

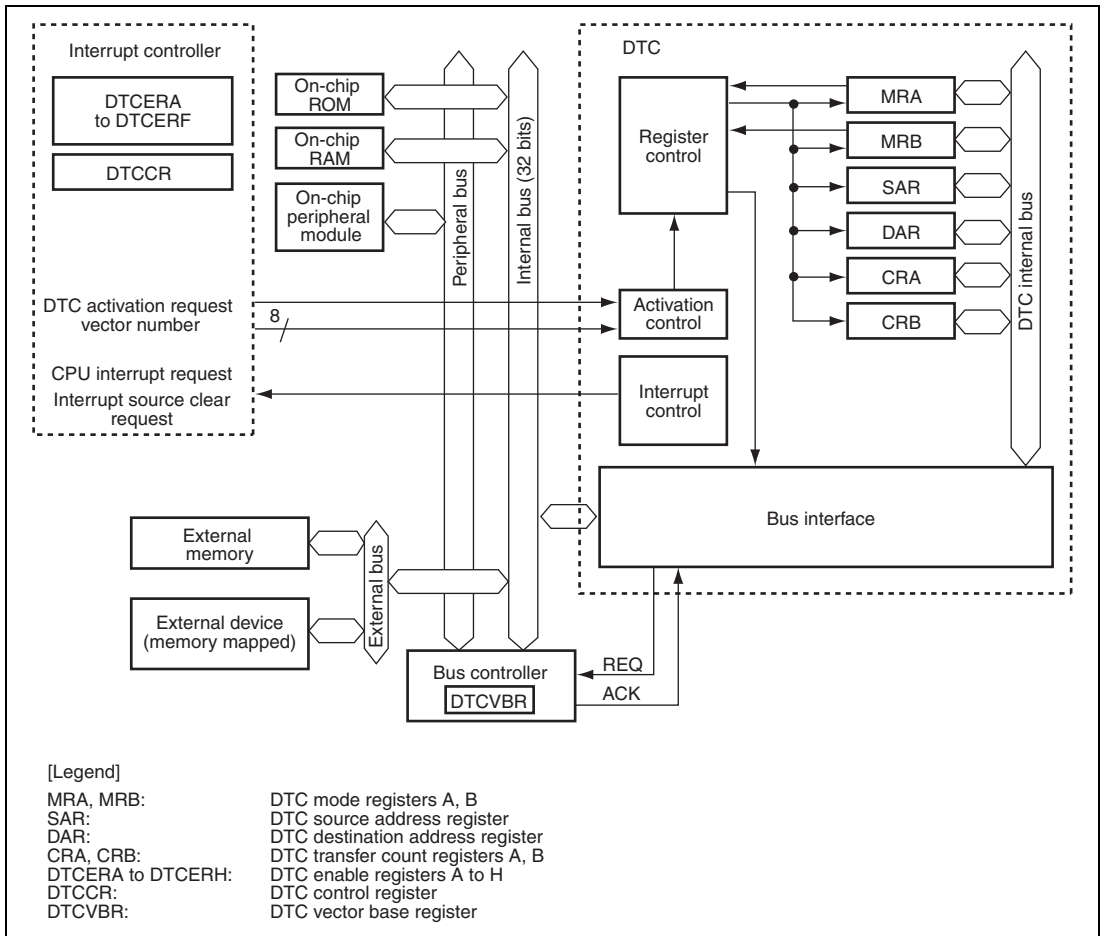

Figure 11.1 Block Diagram of DTC

11.2 Register Descriptions

DTC has the following registers.

- DTC mode register A (MRA)
- DTC mode register B (MRB)
- DTC source address register (SAR)
- DTC destination address register (DAR)
- DTC transfer count register A (CRA)
- DTC transfer count register B (CRB)

These six registers MRA, MRB, SAR, DAR, CRA, and CRB cannot be directly accessed by the CPU. The contents of these registers are stored in the data area as transfer information. When a DTC activation request occurs, the DTC reads a start address of transfer information that is stored in the data area according to the vector address, reads the transfer information, and transfers data. After the data transfer, it writes a set of updated transfer information back to the data area.

- DTC enable registers A to H (DTCERA to DTCERF)
- DTC control register (DTCCR)
- DTC vector base register (DTCVBR)

11.2.1 DTC Mode Register A (MRA)

MRA selects DTC operating mode. MRA cannot be accessed directly by the CPU.

Bit	7	6	5	4	3	2	1	0
Bit Name	MD1	MD0	Sz1	Sz0	SM1	SM0	—	—
Initial Value	Undefined	Undefined	Undefined	Undefined	Undefined	Undefined	Undefined	Undefined
R/W	—	—	—	—	—	—	—	—

Bit	Bit Name	Initial Value	R/W	Description
7	MD1	Undefined	—	DTC Mode 1 and 0
6	MD0	Undefined	—	Specify DTC transfer mode. 00: Normal mode 01: Repeat mode 10: Block transfer mode 11: Setting prohibited
5	Sz1	Undefined	—	DTC Data Transfer Size 1 and 0
4	Sz0	Undefined	—	Specify the size of data to be transferred. 00: Byte-size transfer 01: Word-size transfer 10: Longword-size transfer 11: Setting prohibited
3	SM1	Undefined	—	Source Address Mode 1 and 0
2	SM0	Undefined	—	Specify an SAR operation after a data transfer. 0x: SAR is fixed (SAR writeback is skipped) 10: SAR is incremented after a transfer (by 1 when Sz1 and Sz0 = B'00; by 2 when Sz1 and Sz0 = B'01; by 4 when Sz1 and Sz0 = B'10) 11: SAR is decremented after a transfer (by 1 when Sz1 and Sz0 = B'00; by 2 when Sz1 and Sz0 = B'01; by 4 when Sz1 and Sz0 = B'10)
1, 0	—	Undefined	—	Reserved The write value should always be 0.

[Legend]

X: Don't care

11.2.2 DTC Mode Register B (MRB)

MRB selects DTC operating mode. MRB cannot be accessed directly by the CPU.

Bit	7	6	5	4	3	2	1	0
Bit Name	CHNE	CHNS	DISEL	DTS	DM1	DM0	—	—
Initial Value	Undefined	Undefined	Undefined	Undefined	Undefined	Undefined	Undefined	Undefined
R/W	—	—	—	—	—	—	—	—

Bit	Bit Name	Initial Value	R/W	Description
7	CHNE	Undefined	—	<p>DTC Chain Transfer Enable</p> <p>Specifies the chain transfer. For details, see section 11.5.7, Chain Transfer. The chain transfer condition is selected by the CHNS bit.</p> <p>0: Disables the chain transfer 1: Enables the chain transfer</p>
6	CHNS	Undefined	—	<p>DTC Chain Transfer Select</p> <p>Specifies the chain transfer condition. If the following transfer is a chain transfer, the completion check of the specified transfer count is not performed and activation source flag or DTCER is not cleared.</p> <p>0: Chain transfer every time 1: Chain transfer only when transfer counter = 0</p>
5	DISEL	Undefined	—	<p>DTC Interrupt Select</p> <p>When this bit is set to 1, a CPU interrupt request is generated every time after a data transfer ends. When this bit is set to 0, a CPU interrupt request is only generated when the specified number of data transfer ends.</p>
4	DTS	Undefined	—	<p>DTC Transfer Mode Select</p> <p>Specifies either the source or destination as repeat or block area during repeat or block transfer mode.</p> <p>0: Specifies the destination as repeat or block area 1: Specifies the source as repeat or block area</p>

Bit	Bit Name	Initial Value	R/W	Description
3	DM1	Undefined	—	Destination Address Mode 1 and 0
2	DM0	Undefined	—	Specify a DAR operation after a data transfer. 0X: DAR is fixed (DAR writeback is skipped) 10: DAR is incremented after a transfer (by 1 when Sz1 and Sz0 = B'00; by 2 when Sz1 and Sz0 = B'01; by 4 when Sz1 and Sz0 = B'10) 11: SAR is decremented after a transfer (by 1 when Sz1 and Sz0 = B'00; by 2 when Sz1 and Sz0 = B'01; by 4 when Sz1 and Sz0 = B'10)
1, 0	—	Undefined	—	Reserved The write value should always be 0.

[Legend]

X: Don't care

11.2.3 DTC Source Address Register (SAR)

SAR is a 32-bit register that designates the source address of data to be transferred by the DTC.

In full address mode, 32 bits of SAR are valid. In short address mode, the lower 24 bits of SAR is valid and bits 31 to 24 are ignored. At this time, the upper eight bits are filled with the value of bit 23.

If a word or longword access is performed while an odd address is specified in SAR or if a longword access is performed while address $4n + 2$ is specified in SAR, the bus cycle is divided into multiple cycles to transfer data. For details, see section 11.5.1, Bus Cycle Division.

SAR cannot be accessed directly from the CPU.

11.2.4 DTC Destination Address Register (DAR)

DAR is a 32-bit register that designates the destination address of data to be transferred by the DTC.

In full address mode, 32 bits of DAR are valid. In short address mode, the lower 24 bits of DAR is valid and bits 31 to 24 are ignored. At this time, the upper eight bits are filled with the value of bit 23.

If a word or longword access is performed while an odd address is specified in DAR or if a longword access is performed while address $4n + 2$ is specified in DAR, the bus cycle is divided into multiple cycles to transfer data. For details, see section 11.5.1, Bus Cycle Division.

DAR cannot be accessed directly from the CPU.

11.2.5 DTC Transfer Count Register A (CRA)

CRA is a 16-bit register that designates the number of times data is to be transferred by the DTC.

In normal transfer mode, CRA functions as a 16-bit transfer counter (1 to 65,536). It is decremented by 1 every time data is transferred, and bit DTCE_n ($n = 15$ to 0) corresponding to the activation source is cleared and then an interrupt is requested to the CPU when the count reaches H'0000. The transfer count is 1 when CRA = H'0001, 65,535 when CRA = H'FFFF, and 65,536 when CRA = H'0000.

In repeat transfer mode, CRA is divided into two parts: the upper eight bits (CRAH) and the lower eight bits (CRAL). CRAH holds the number of transfers while CRAL functions as an 8-bit transfer counter (1 to 256). CRAL is decremented by 1 every time data is transferred, and the contents of CRAH are sent to CRAL when the count reaches H'00. The transfer count is 1 when CRAH = CRAL = H'01, 255 when CRAH = CRAL = H'FF, and 256 when CRAH = CRAL = H'00.

In block transfer mode, CRA is divided into two parts: the upper eight bits (CRAH) and the lower eight bits (CRAL). CRAH holds the block size while CRAL functions as an 8-bit block-size counter (1 to 256 for byte, word, or longword). CRAL is decremented by 1 every time a byte (word or longword) data is transferred, and the contents of CRAH are sent to CRAL when the count reaches H'00. The block size is 1 byte (word or longword) when CRAH = CRAL = H'01, 255 bytes (words or longwords) when CRAH = CRAL = H'FF, and 256 bytes (words or longwords) when CRAH = CRAL = H'00.

CRA cannot be accessed directly from the CPU.

11.2.6 DTC Transfer Count Register B (CRB)

CRB is a 16-bit register that designates the number of times data is to be transferred by the DTC in block transfer mode. It functions as a 16-bit transfer counter (1 to 65,536) that is decremented by 1 every time data is transferred, and bit DTCE_n (n = 15 to 0) corresponding to the activation source is cleared and then an interrupt is requested to the CPU when the count reaches H'0000. The transfer count is 1 when CRB = H'0001, 65,535 when CRB = H'FFFF, and 65,536 when CRB = H'0000.

CRB is not available in normal and repeat modes and cannot be accessed directly by the CPU.

11.2.7 DTC enable registers A to H (DTCERA to DTCERF)

DTCER, which is comprised of eight registers, DTCERA to DTCERF, is a register that specifies DTC activation interrupt sources. The correspondence between interrupt sources and DTCE bits is shown in Table 11.1. Use bit manipulation instructions such as BSET and BCLR to read or write a DTCE bit. If all interrupts are masked, multiple activation sources can be set at one time (only at the initial setting) by writing data after executing a dummy read on the relevant register.

Bit	15	14	13	12	11	10	9	8
Bit Name	DTCE15	DTCE14	DTCE13	DTCE12	DTCE11	DTCE10	DTCE9	DTCE8
Initial Value	0	0	0	0	0	0	0	0
R/W	R/W	R/W	R/W	R/W	R/W	R/W	R/W	R/W
Bit	7	6	5	4	3	2	1	0
Bit Name	DTCE7	DTCE6	DTCE5	DTCE4	DTCE3	DTCE2	DTCE1	DTCE0
Initial Value	0	0	0	0	0	0	0	0
R/W	R/W	R/W	R/W	R/W	R/W	R/W	R/W	R/W

Bit	Bit Name	Initial Value	R/W	Description
15	DTCE15	0	R/W	DTC Activation Enable 15 to 0
14	DTCE14	0	R/W	Setting this bit to 1 specifies a relevant interrupt source to a DTC activation source. [Clearing conditions] <ul style="list-style-type: none"> • When writing 0 to the bit to be cleared after reading 1 • When the DISEL bit is 1 and the data transfer has ended • When the specified number of transfers have ended These bits are not cleared when the DISEL bit is 0 and the specified number of transfers have not ended
13	DTCE13	0	R/W	
12	DTCE12	0	R/W	
11	DTCE11	0	R/W	
10	DTCE10	0	R/W	
9	DTCE9	0	R/W	
8	DTCE8	0	R/W	
7	DTCE7	0	R/W	
6	DTCE6	0	R/W	
5	DTCE5	0	R/W	
4	DTCE4	0	R/W	
3	DTCE3	0	R/W	
2	DTCE2	0	R/W	
1	DTCE1	0	R/W	
0	DTCE0	0	R/W	

11.2.8 DTC Control Register (DTCCR)

DTCCR specifies transfer information read skip.

Bit	7	6	5	4	3	2	1	0
Bit Name	—	—	—	RRS	RCHNE	—	—	ERR
Initial Value	0	0	0	0	0	0	0	0
R/W	R/W	R/W	R/W	R/W	R/W	R	R	R/(W)*

Note: * Only 0 can be written to clear the flag.

Bit	Bit Name	Initial Value	R/W	Description
7 to 5	—	All 0	R/W	Reserved
				These bits are always read as 0. The write value should always be 0.

Bit	Bit Name	Initial Value	R/W	Description
4	RRS	0	R/W	<p>DTC Transfer Information Read Skip Enable</p> <p>Controls the vector address read and transfer information read. A DTC vector number is always compared with the vector number for the previous activation. If the vector numbers match and this bit is set to 1, the DTC data transfer is started without reading a vector address and transfer information. If the previous DTC activation is a chain transfer, the vector address read and transfer information read are always performed.</p> <p>0: Transfer read skip is not performed. 1: Transfer read skip is performed when the vector numbers match.</p>
3	RCHNE	0	R/W	<p>Chain Transfer Enable After DTC Repeat Transfer</p> <p>Enables/disables the chain transfer while transfer counter (CRAL) is 0 in repeat transfer mode.</p> <p>In repeat transfer mode, the CRAH value is written to CRAL when CRAL is 0. Accordingly, chain transfer may not occur when CRAL is 0. If this bit is set to 1, the chain transfer is enabled when CRAH is written to CRAL.</p> <p>0: Disables the chain transfer after repeat transfer 1: Enables the chain transfer after repeat transfer</p>
2, 1	—	All 0	R	<p>Reserved</p> <p>These are read-only bits and cannot be modified.</p>
0	ERR	0	R/(W)*	<p>Transfer Stop Flag</p> <p>Indicates that an address error or an NMI interrupt occurs. If an address error or an NMI interrupt occurs, the DTC stops.</p> <p>0: No interrupt occurs 1: An interrupt occurs [Clearing condition]</p> <ul style="list-style-type: none"> When writing 0 after reading 1

Note: * Only 0 can be written to clear this flag.

11.2.9 DTC Vector Base Register (DTCVBR)

DTCVBR is a 32-bit register that specifies the base address for vector table address calculation. Bits 31 to 28 and bits 11 to 0 are fixed 0 and cannot be written to. The initial value of DTCVBR is H'00000000.

Bit	31	30	29	28	27	26	25	24	23	22	21	20	19	18	17	16
Bit Name																
Initial Value	0	0	0	0	0	0	0	0	0	0	0	0	0	0	0	0
R/W	R	R	R	R	R/W	R/W	R/W	R/W	R/W	R/W	R/W	R/W	R/W	R/W	R/W	R/W
Bit	15	14	13	12	11	10	9	8	7	6	5	4	3	2	1	0
Bit Name																
Initial Value	0	0	0	0	0	0	0	0	0	0	0	0	0	0	0	0
R/W	R/W	R/W	R/W	R/W	R	R	R	R	R	R	R	R	R	R	R	R

11.3 Activation Sources

The DTC is activated by an interrupt request. The interrupt source is selected by DTCER. A DTC activation source can be selected by setting the corresponding bit in DTCER; the CPU interrupt source can be selected by clearing the corresponding bit in DTCER. At the end of a data transfer (or the last consecutive transfer in the case of chain transfer), the activation source interrupt flag or corresponding DTCER bit is cleared.

11.4 Location of Transfer Information and DTC Vector Table

Locate the transfer information in the data area. The start address of transfer information should be located at the address that is a multiple of four (4n). Otherwise, the lower two bits are ignored during access ([1:0] = B'00.) Transfer information can be located in either short address mode (three longwords) or full address mode (four longwords). The DTCMD bit in SYSCR specifies either short address mode (DTCMD = 1) or full address mode (DTCMD = 0). For details, see section 3.2.2, System Control Register (SYSCR). Transfer information located in the data area is shown in Figure 11.2

The DTC reads the start address of transfer information from the vector table according to the activation source, and then reads the transfer information from the start address. Figure 11.3 shows correspondences between the DTC vector address and transfer information.

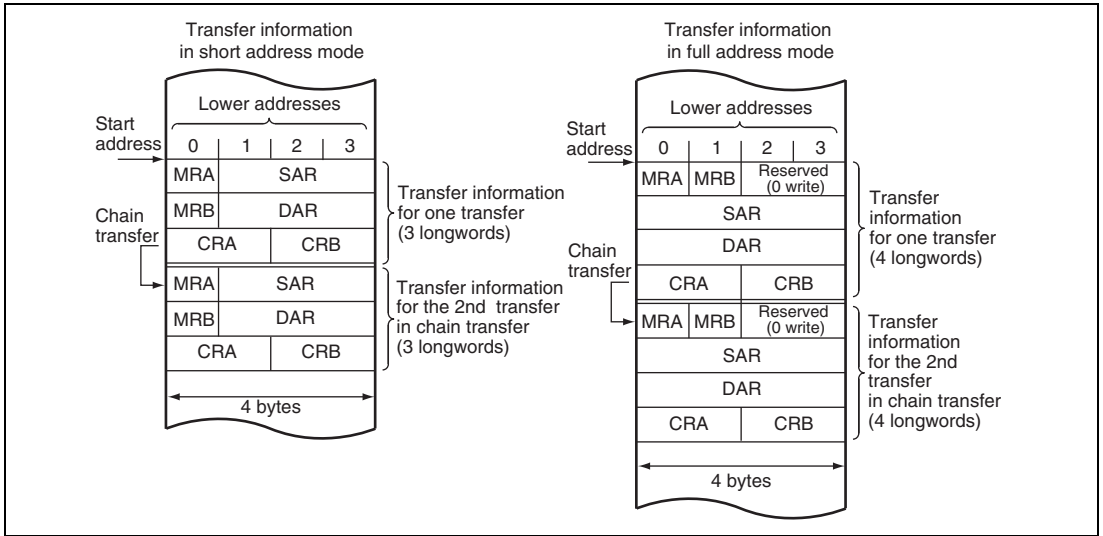

Figure 11.2 Transfer Information on Data Area

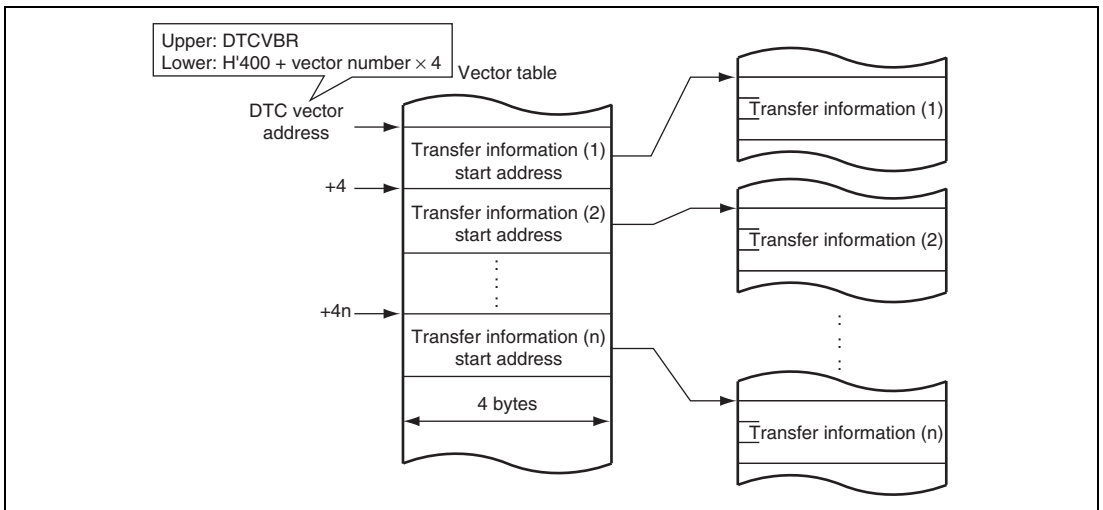
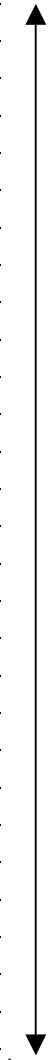

Figure 11.3 Correspondence between DTC Vector Address and Transfer Information

Table 11.1 shows correspondence between the DTC activation source and vector address.

Table 11.1 Interrupt Sources, DTC Vector Addresses, and Corresponding DTCEs

Origin of Activation Source	Activation Source	Vector Number	DTC Vector Address Offset	DTCE*	Priority
External pin	IRQ0	64	H'500	DTCEA15	
	IRQ1	65	H'504	DTCEA14	
	IRQ2	66	H'508	DTCEA13	
	IRQ3	67	H'50C	DTCEA12	
	IRQ4	68	H'510	DTCEA11	
	IRQ5	69	H'514	DTCEA10	
	IRQ6	70	H'518	DTCEA9	
	IRQ7	71	H'51C	DTCEA8	
	IRQ8	72	H'520	DTCEA7	
	IRQ9	73	H'524	DTCEA6	
	IRQ10	74	H'528	DTCEA5	
	IRQ11	75	H'52C	DTCEA4	
	IRQ12	76	H'530	DTCEA3	
	IRQ13	77	H'534	DTCEA2	
	IRQ14	78	H'538	DTCEA1	
	IRQ15	79	H'53C	DTCEA0	
A/D_0	AD10 (A/D_0 conversion end)	86	H'558	DTCEB15	
TPU_0	TGI0A	88	H'560	DTCEB13	
	TGI0B	89	H'564	DTCEB12	
	TGI0C	90	H'568	DTCEB11	
	TGI0D	91	H'56C	DTCEB10	
TPU_1	TGI1A	93	H'574	DTCEB9	
	TGI1B	94	H'578	DTCEB8	
TPU_2	TGI2A	97	H'584	DTCEB7	
	TGI2B	98	H'588	DTCEB6	
TPU_3	TGI3A	101	H'594	DTCEB5	
	TGI3B	102	H'598	DTCEB4	
	TGI3C	103	H'59C	DTCEB3	
	TGI3D	104	H'5A0	DTCEB2	Low

Origin of Activation Source	Activation Source	Vector Number	DTC Vector Address Offset	DTCE*	Priority
TPU_4	TGI4A	106	H'5A8	DTCEB1	High
	TGI4B	107	H'5AC	DTCEB0	
TPU_5	TGI5A	110	H'5B8	DTCEC15	
	TGI5B	111	H'5BC	DTCEC14	
TMR_0	CMI0A	116	H'5D0	DTCEC13	
	CMI0B	117	H'5D4	DTCEC12	
TMR_1	CMI1A	119	H'5DC	DTCEC11	
	CMI1B	120	H'5E0	DTCEC10	
TMR_2	CMI2A	122	H'5E8	DTCEC9	
	CMI2B	123	H'5EC	DTCEC8	
TMR_3	CMI3A	125	H'5F4	DTCEC7	
	CMI3B	126	H'5F8	DTCEC6	
DMAC	DMTEND0	128	H'600	DTCEC5	
	DMTEND1	129	H'604	DTCEC4	
	DMTEND2	130	H'608	DTCEC3	
	DMTEND3	131	H'60C	DTCEC2	
DMAC	DMEEND0	136	H'620	DTCED13	
	DMEEND1	137	H'624	DTCED12	
	DMEEND2	138	H'628	DTCED11	
	DMEEND3	139	H'62C	DTCED10	
SCI_0	RXI0	145	H'644	DTCED5	
	TXI0	146	H'648	DTCED4	
SCI_1	RXI1	149	H'654	DTCED3	
	TXI1	150	H'658	DTCED2	
SCI_2	RXI2	153	H'664	DTCED1	
	TXI2	154	H'668	DTCED0	
SCI_3	RXI3	157	H'674	DTCED15	
	TXI3	158	H'678	DTCED14	
SCI_4	RXI4	161	H'684	DTCEE13	Low
	TXI4	162	H'688	DTCEE12	

Origin of Activation Source	Activation Source	Vector Number	DTC Vector Address Offset	DTCE*	Priority
TPU_6	TGI6A	164	H'690	DTCEE11	High ↑ ↓ Low
	TGI6B	165	H'694	DTCEE10	
	TGI6C	166	H'698	DTCEE9	
	TGI6D	167	H'69C	DTCEE8	
TPU_7	TGI7A	169	H'6A4	DTCEE7	
	TGI7B	170	H'6A8	DTCEE6	
TPU_8	TGI8A	173	H'6B4	DTCEE5	
	TGI8B	174	H'6B8	DTCEE4	
TPU_9	TGI9A	177	H'6C4	DTCEE3	
	TGI9B	178	H'6C8	DTCEE2	
	TGI9C	179	H'6CC	DTCEE1	
	TGI9D	180	H'6D0	DTCEE0	
TPU_10	TGI10A	182	H'6D8	DTCEF15	
	TGI10B	183	H'6DC	DTCEF14	
	TGI10V	186	H'6E8	DTCEF11	
TPU_11	TGI11A	188	H'6F0	DTCEF10	
	TGI11B	189	H'6F4	DTCEF9	Low

Note: * The DTCE bits with no corresponding interrupt are reserved, and the write value should always be 0. To leave software standby mode or all-module-clock-stop mode with an interrupt, write 0 to the corresponding DTCE bit.

11.5 Operation

The DTC stores transfer information in the data area. When activated, the DTC reads transfer information that is stored in the data area and transfers data on the basis of that transfer information. After the data transfer, it writes updated transfer information back to the data area. Since transfer information is in the data area, it is possible to transfer data over any required number of channels. There are three transfer modes: normal, repeat, and block.

The DTC specifies the source address and destination address in SAR and DAR, respectively. After a transfer, SAR and DAR are incremented, decremented, or fixed independently.

Table 11.2 shows the DTC transfer modes.

Table 11.2 DTC Transfer Modes

Transfer Mode	Size of Data Transferred at One Transfer Request	Memory Address Increment or Decrement	Transfer Count
Normal	1 byte/word/longword	Incremented/decremented by 1, 2, or 4, or fixed	1 to 65536
Repeat* ¹	1 byte/word/longword	Incremented/decremented by 1, 2, or 4, or fixed	1 to 256* ³
Block* ²	Block size specified by CRAH (1 to 256 bytes/words/longwords)	Incremented/decremented by 1, 2, or 4, or fixed	1 to 65536

Notes: 1. Either source or destination is specified to repeat area.
 2. Either source or destination is specified to block area.
 3. After transfer of the specified transfer count, initial state is recovered to continue the operation.

Setting the CHNE bit in MRB to 1 makes it possible to perform a number of transfers with a single activation (chain transfer). Setting the CHNS bit in MRB to 1 can also be made to have chain transfer performed only when the transfer counter value is 0.

Figure 11.4 shows a flowchart of DTC operation, and Table 11.3 summarizes the chain transfer conditions (combinations for performing the second and third transfers are omitted).

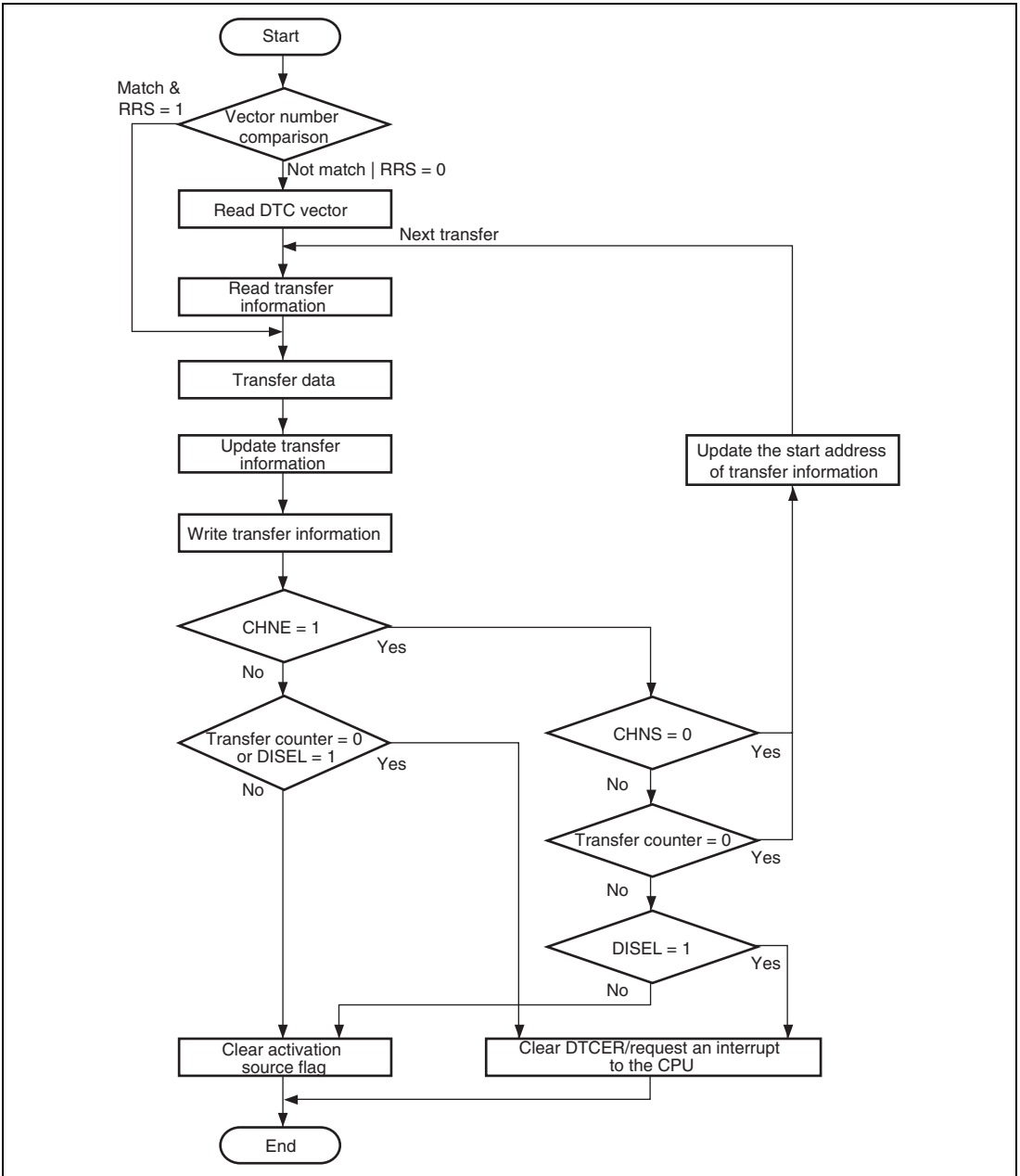

Figure 11.4 Flowchart of DTC Operation

Table 11.3 Chain Transfer Conditions

1st Transfer				2nd Transfer				DTC Transfer
CHNE	CHNS	DISEL	Transfer Counter* ¹	CHNE	CHNS	DISEL	Transfer Counter* ¹	
0	—	0	Not 0	—	—	—	—	Ends at 1st transfer
0	—	0	0* ²	—	—	—	—	Ends at 1st transfer
0	—	1	—	—	—	—	—	Interrupt request to CPU
1	0	—	—	0	—	0	Not 0	Ends at 2nd transfer
				0	—	0	0* ²	Ends at 2nd transfer
				0	—	1	—	Interrupt request to CPU
1	1	0	Not 0	—	—	—	—	Ends at 1st transfer
1	1	—	0* ²	0	—	0	Not 0	Ends at 2nd transfer
				0	—	0	0* ²	Ends at 2nd transfer
				0	—	1	—	Interrupt request to CPU
1	1	1	Not 0	—	—	—	—	Ends at 1st transfer
								Interrupt request to CPU

Notes: 1. CRA in normal mode transfer, CRAL in repeat transfer mode, or CRB in block transfer mode

2. When the contents of the CRAH is written to the CRAL in repeat transfer mode

11.5.1 Bus Cycle Division

When the transfer data size is word and the SAR and DAR values are not a multiple of 2, the bus cycle is divided and the transfer data is read from or written to in bytes.

Table 11.4 shows the relationship among, SAR, DAR, transfer data size, bus cycle divisions, and access data size. Figure 11.5 shows the bus cycle division example.

Table 11.4 Number of Bus Cycle Divisions and Access Size

SAR and DAR Values	Specified Data Size		
	Byte (B)	Word (W)	Longword (LW)
Address 4n	1 (B)	1 (W)	1 (LW)
Address 2n + 1	1 (B)	2 (B-B)	3 (B-W-B)
Address 4n + 2	1 (B)	1 (W)	2 (W-W)

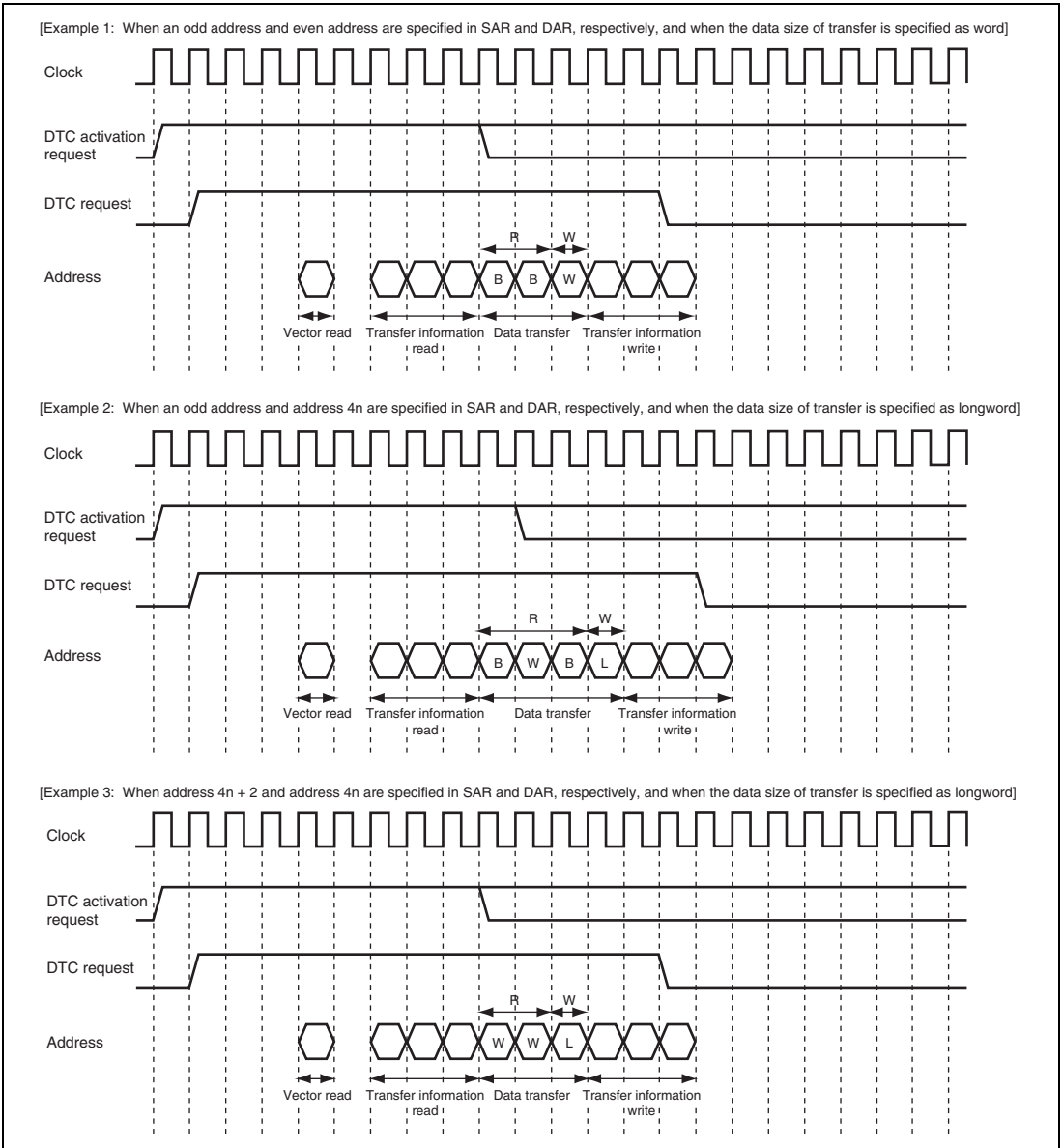

Figure 11.5 Bus Cycle Division Example

11.5.2 Transfer Information Read Skip Function

By setting the RRS bit of DTCCR, the vector address read and transfer information read can be skipped. The current DTC vector number is always compared with the vector number of previous activation. If the vector numbers match when $RRS = 1$, a DTC data transfer is performed without reading the vector address and transfer information. If the previous activation is a chain transfer, the vector address read and transfer information read are always performed. Figure 11.6 shows the transfer information read skip timing.

To modify the vector table and transfer information, temporarily clear the RRS bit to 0, modify the vector table and transfer information, and then set the RRS bit to 1 again. When the RRS bit is cleared to 0, the stored vector number is deleted, and the updated vector table and transfer information are read at the next activation.

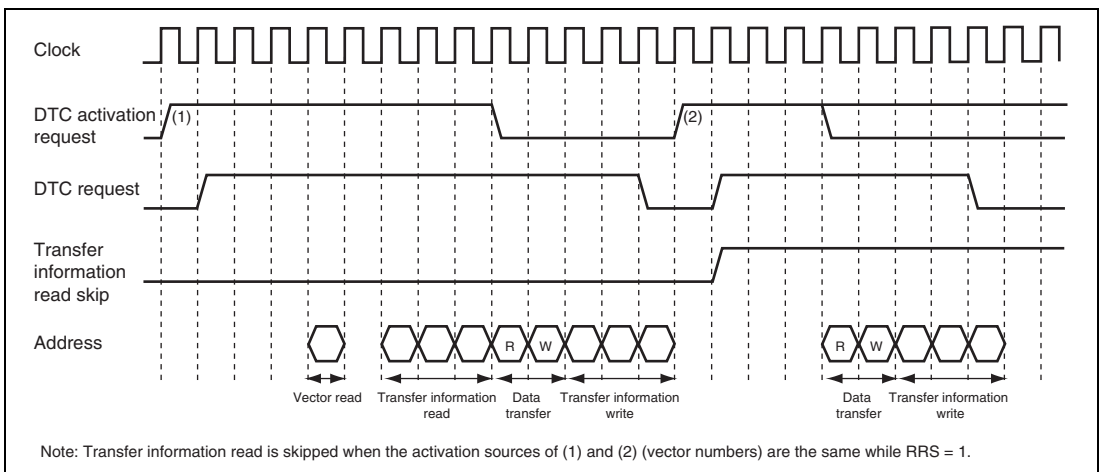

Figure 11.6 Transfer Information Read Skip Timing

11.5.3 Transfer Information Writeback Skip Function

By specifying bit SM1 in MRA and bit DM1 in MRB to the fixed address mode, a part of transfer information will not be written back. This function is performed regardless of short or full address mode. Table 11.5 shows the transfer information writeback skip condition and writeback skipped registers. Note that the CRA and CRB are always written back regardless of the short or full address mode. In addition in full address mode, the writeback of the MRA and MRB are always skipped.

Table 11.5 Transfer Information Writeback Skip Condition and Writeback Skipped Registers

SM1	DM1	SAR	DAR
0	0	Skipped	Skipped
0	1	Skipped	Written back
1	0	Written back	Skipped
1	1	Written back	Written back

11.5.4 Normal Transfer Mode

In normal transfer mode, one operation transfers one byte, one word, or one longword of data. From 1 to 65,536 transfers can be specified. The transfer source and destination addresses can be specified as incremented, decremented, or fixed. When the specified number of transfers ends, an interrupt can be requested to the CPU.

Table 11.6 lists the register function in normal transfer mode. Figure 11.7 shows the memory map in normal transfer mode.

Table 11.6 Register Function in Normal Transfer Mode

Register	Function	Written Back Value
SAR	Source address	Incremented/decremented/fixed*
DAR	Destination address	Incremented/decremented/fixed*
CRA	Transfer count A	CRA – 1
CRB	Transfer count B	Not updated

Note: * Transfer information writeback is skipped.

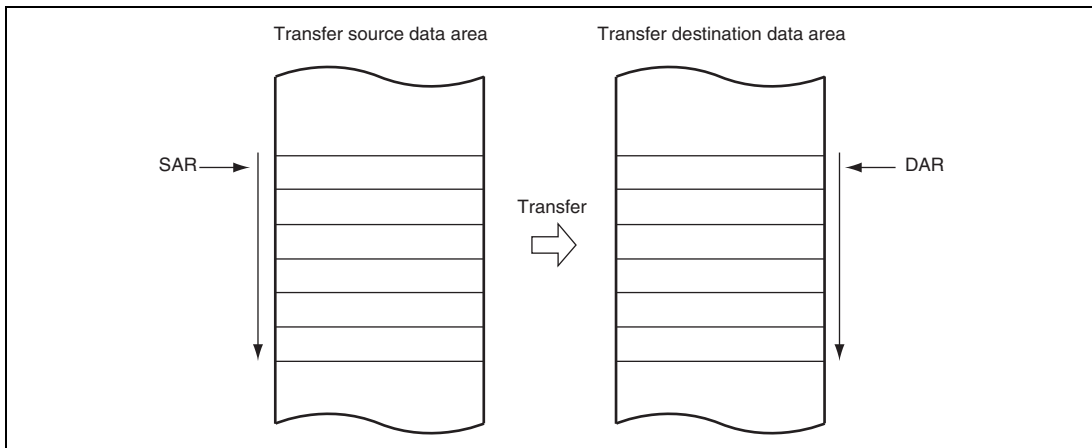

Figure 11.7 Memory Map in Normal Transfer Mode

11.5.5 Repeat Transfer Mode

In repeat transfer mode, one operation transfers one byte, one word, or one longword of data. By the DTS bit in MRB, either the source or destination can be specified as a repeat area. From 1 to 256 transfers can be specified. When the specified number of transfers ends, the transfer counter and address register specified as the repeat area is restored to the initial state, and transfer is repeated. The other address register is then incremented, decremented, or left fixed. In repeat transfer mode, the transfer counter (CRAL) is updated to the value specified in CRAH when CRAL becomes H'00. Thus the transfer counter value does not reach H'00, and therefore a CPU interrupt cannot be requested when $DISEL = 0$.

Table 11.7 lists the register function in repeat transfer mode. Figure 11.8 shows the memory map in repeat transfer mode.

Table 11.7 Register Function in Repeat Transfer Mode

Register	Function	Written Back Value	
		CRAL is not 1	CRAL is 1
SAR	Source address	Incremented/decremented/fixed*	DTS = 0: Incremented/ decremented/fixed* DTS = 1: SAR initial value
DAR	Destination address	Incremented/decremented/fixed*	DTS = 0: DAR initial value DTS = 1: Incremented/ decremented/fixed*
CRAH	Transfer count storage	CRAH	CRAH
CRAL	Transfer count A	CRAL – 1	CRAH
CRB	Transfer count B	Not updated	Not updated

Note: * Transfer information writeback is skipped.

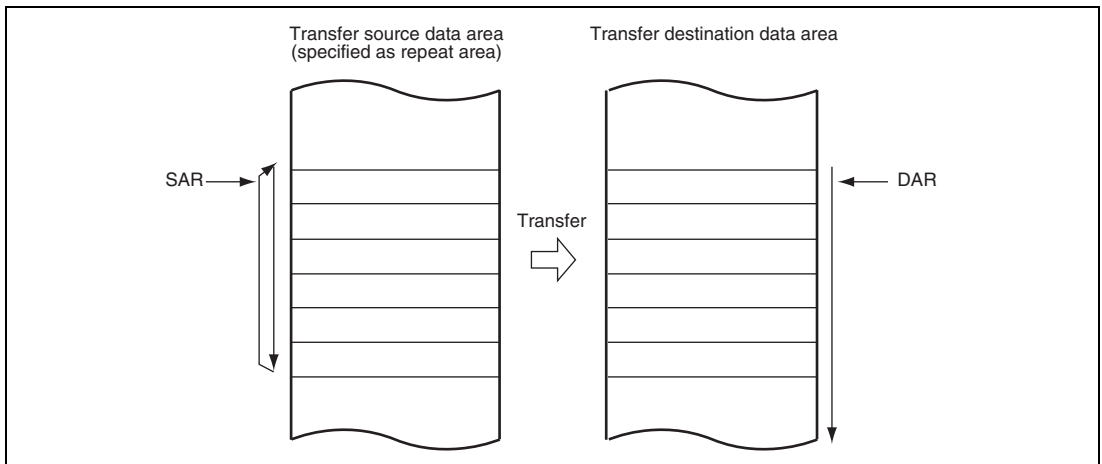

**Figure 11.8 Memory Map in Repeat Transfer Mode
(When Transfer Source is Specified as Repeat Area)**

11.5.6 Block Transfer Mode

In block transfer mode, one operation transfers one block of data. Either the transfer source or the transfer destination is designated as a block area by the DTS bit in MRB.

The block size is 1 to 256 bytes (1 to 256 words, or 1 to 256 longwords). When the transfer of one block ends, the block size counter (CRAL) and address register (SAR when DTS = 1 or DAR when DTS = 0) specified as the block area is restored to the initial state. The other address register is then incremented, decremented, or left fixed. From 1 to 65,536 transfers can be specified. When the specified number of transfers ends, an interrupt is requested to the CPU.

Table 11.8 lists the register function in block transfer mode. Figure 11.9 shows the memory map in block transfer mode.

Table 11.8 Register Function in Block Transfer Mode

Register	Function	Written Back Value
SAR	Source address	DTS = 0: Incremented/decremented/fixed* DTS = 1: SAR initial value
DAR	Destination address	DTS = 0: DAR initial value DTS = 1: Incremented/decremented/fixed*
CRAH	Block size storage	CRAH
CRAL	Block size counter	CRAL
CRB	Block transfer counter	CRB - 1

Note: * Transfer information writeback is skipped.

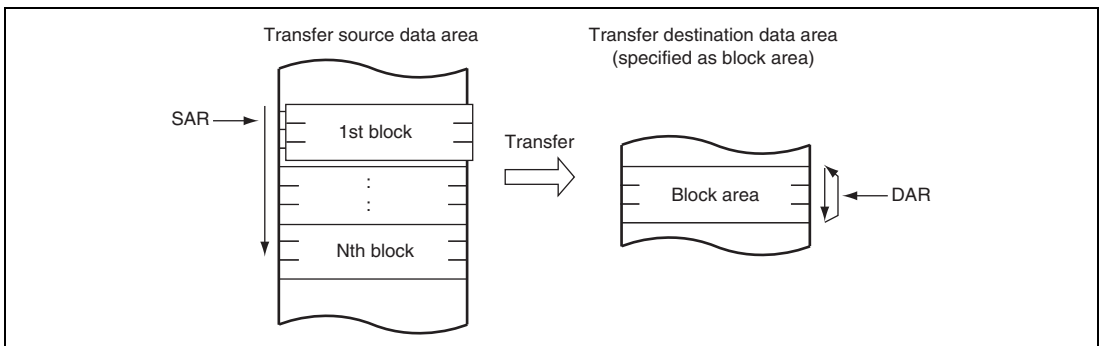

**Figure 11.9 Memory Map in Block Transfer Mode
(When Transfer Destination is Specified as Block Area)**

11.5.7 Chain Transfer

Setting the CHNE bit in MRB to 1 enables a number of data transfers to be performed consecutively in response to a single transfer request. Setting the CHNE and CHNS bits in MRB set to 1 enables a chain transfer only when the transfer counter reaches 0. SAR, DAR, CRA, CRB, MRA, and MRB, which define data transfers, can be set independently. Figure 11.10 shows the chain transfer operation.

In the case of transfer with CHNE set to 1, an interrupt request to the CPU is not generated at the end of the specified number of transfers or by setting the DISEL bit to 1, and the interrupt source flag for the activation source and DTCER are not affected.

In repeat transfer mode, setting the RCHNE bit in DTCCR and the CHNE and CHNS bits in MRB to 1 enables a chain transfer after transfer with transfer counter = 1 has been completed.

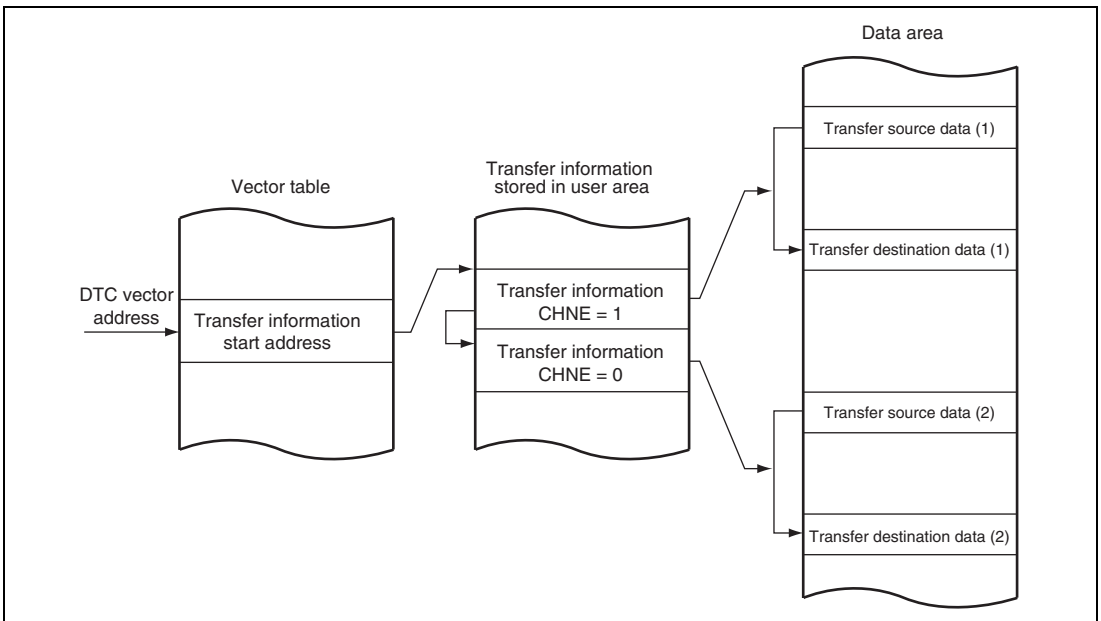

Figure 11.10 Operation of Chain Transfer

11.5.8 Operation Timing

Figures 11.11 to 11.14 show the DTC operation timings.

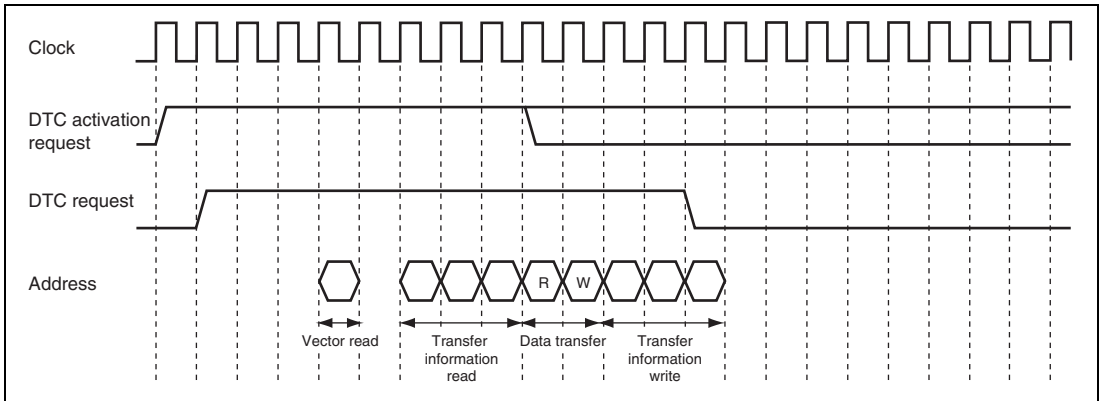

Figure 11.11 DTC Operation Timing

(Example of Short Address Mode in Normal Transfer Mode or Repeat Transfer Mode)

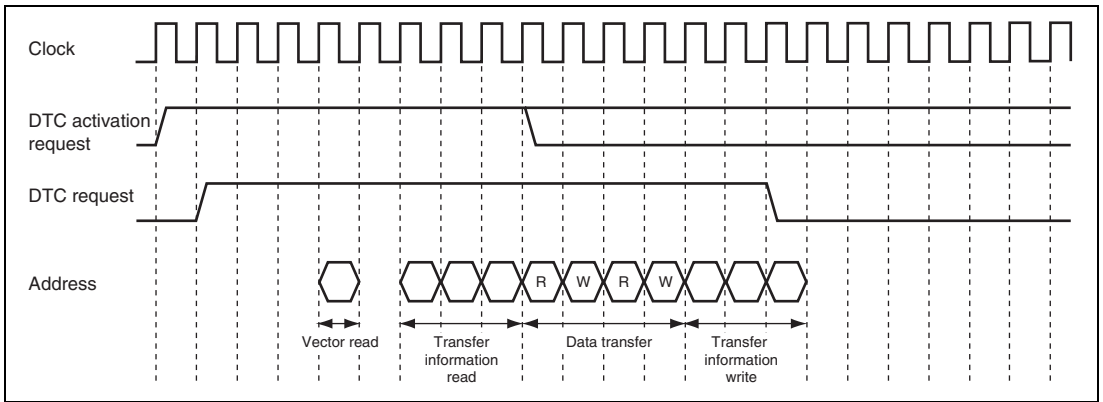

Figure 11.12 DTC Operation Timing

(Example of Short Address Mode in Block Transfer Mode with Block Size of 2)

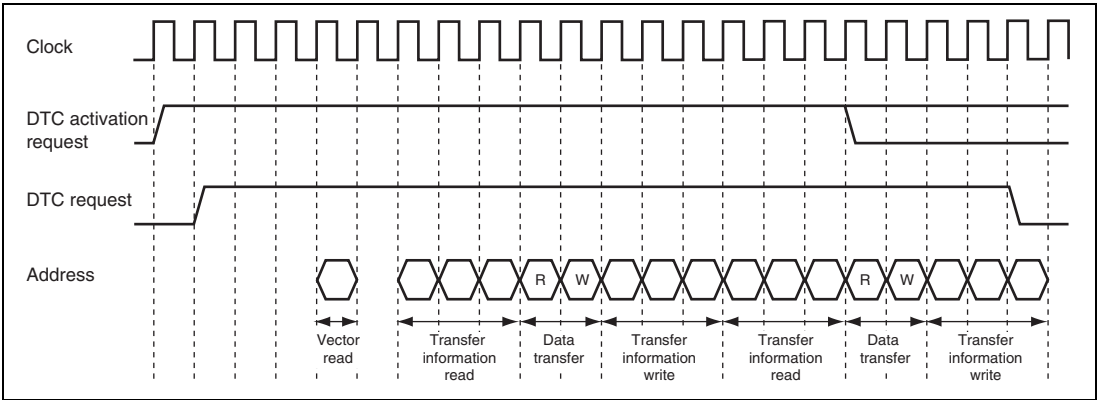

Figure 11.13 DTC Operation Timing (Example of Short Address Mode in Chain Transfer)

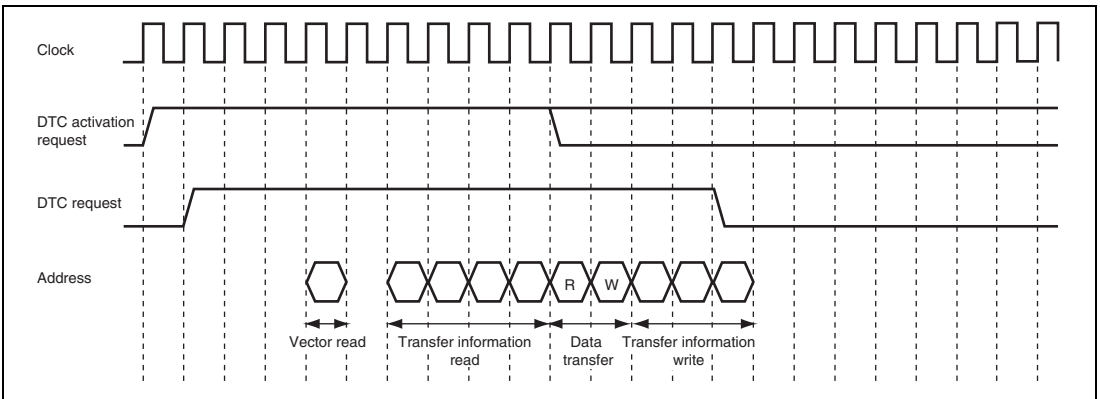

Figure 11.14 DTC Operation Timing (Example of Full Address Mode in Normal Transfer Mode or Repeat Transfer Mode)

11.5.9 Number of DTC Execution Cycles

Table 11.9 shows the execution status for a single DTC data transfer, and Table 11.10 shows the number of cycles required for each execution.

Table 11.9 DTC Execution Status

Mode	Vector Read		Transfer Information Read			Transfer Information Write			Data Read		Data Write		Internal Operation			
	I	0* ¹	4* ²	3* ³	0* ¹	3* ^{2,3}	2* ⁴	1* ⁵	3* ⁶	2* ⁷	1	3* ⁶	2* ⁷	1	1	0* ¹
Normal	1	0* ¹	4* ²	3* ³	0* ¹	3* ^{2,3}	2* ⁴	1* ⁵	3* ⁶	2* ⁷	1	3* ⁶	2* ⁷	1	1	0* ¹
Repeat	1	0* ¹	4* ²	3* ³	0* ¹	3* ^{2,3}	2* ⁴	1* ⁵	3* ⁶	2* ⁷	1	3* ⁶	2* ⁷	1	1	0* ¹
Block transfer	1	0* ¹	4* ²	3* ³	0* ¹	3* ^{2,3}	2* ⁴	1* ⁵	3•P* ⁶	2•P* ⁷	1•P	3•P* ⁶	2•P* ⁷	1•P	1	0* ¹

[Legend]

P: Block size (CRAH and CRAL value)

- Note:
1. When transfer information read is skipped
 2. In full address mode operation
 3. In short address mode operation
 4. When the SAR or DAR is in fixed mode
 5. When the SAR and DAR are in fixed mode
 6. When a longword is transferred while an odd address is specified in the address register
 7. When a word is transferred while an odd address is specified in the address register or when a longword is transferred while address $4n + 2$ is specified

Table 11.10 Number of Cycles Required for Each Execution State

Object to be Accessed	On-Chip		On-Chip I/O			External Devices				
	RAM	ROM	Registers							
Bus width	32	32	8	16	32	8			16	
Access cycles	1	1	2	2	2	2	3	2	3	
Execution status	Vector read S_i	1	1	—	—	—	8	12 + 4m	4	6 + 2m
	Transfer information read S_j	1	1	—	—	—	8	12 + 4m	4	6 + 2m
	Transfer information write S_k	1	1	—	—	—	8	12 + 4m	4	6 + 2m
	Byte data read S_L	1	1	2	2	2	2	3 + m	2	3 + m
	Word data read S_L	1	1	4	2	2	4	4 + 2m	2	3 + m
	Longword data read S_L	1	1	8	4	2	8	12 + 4m	4	6 + 2m
	Byte data write S_M	1	1	2	2	2	2	3 + m	2	3 + m
	Word data write S_M	1	1	4	2	2	4	4 + 2m	2	3 + m
	Longword data write S_M	1	1	8	4	2	8	12 + 4m	4	6 + 2m
	Internal operation S_N						1			

[Legend]

m: Number of wait cycles 0 to 7 (For details, see section 9, Bus Controller (BSC).)

The number of execution cycles is calculated from the formula below. Note that Σ means the sum of all transfers activated by one activation event (the number in which the CHNE bit is set to 1, plus 1).

$$\text{Number of execution cycles} = I \cdot S_i + \Sigma (J \cdot S_j + K \cdot S_k + L \cdot S_L + M \cdot S_M) + N \cdot S_N$$

11.5.10 DTC Bus Release Timing

The DTC requests the bus mastership to the bus arbiter when an activation request occurs. The DTC releases the bus after a vector read, transfer information read, a single data transfer, or transfer information writeback. The DTC does not release the bus during transfer information read, single data transfer, or transfer information writeback.

11.5.11 DTC Priority Level Control to the CPU

The priority of the DTC activation sources over the CPU can be controlled by the CPU priority level specified by bits CPUP2 to CPUP0 in CPUPCR and the DTC priority level specified by bits DTCP2 to DTCP0. For details, see section 7, Interrupt Controller.

11.6 DTC Activation by Interrupt

The procedure for using the DTC with interrupt activation is shown in Figure 11.15.

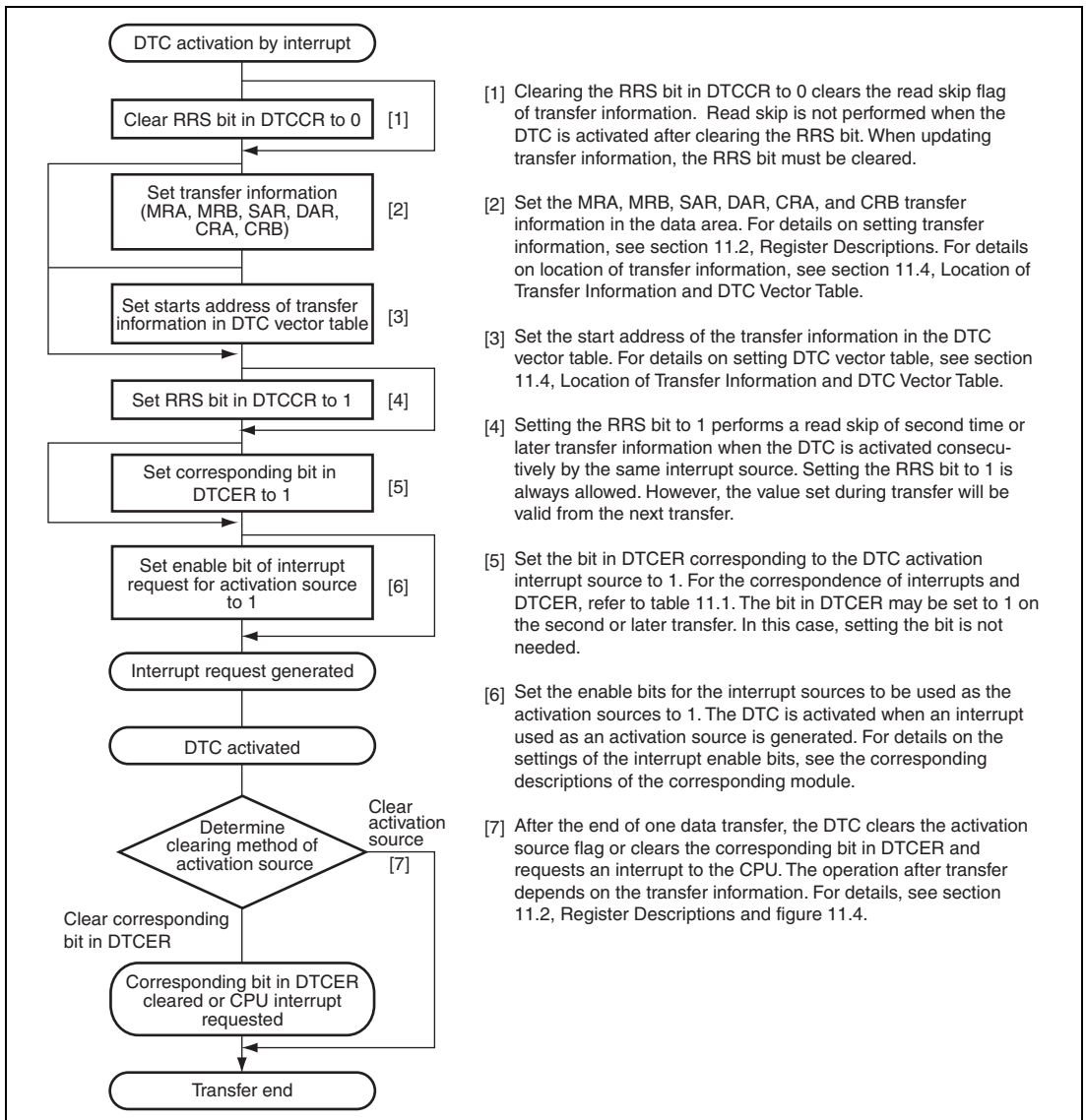

Figure 11.15 DTC with Interrupt Activation

11.7 Examples of Use of the DTC

11.7.1 Normal Transfer Mode

An example is shown in which the DTC is used to receive 128 bytes of data via the SCI.

1. Set MRA to fixed source address ($SM1 = SM0 = 0$), incrementing destination address ($DM1 = 1, DM0 = 0$), normal transfer mode ($MD1 = MD0 = 0$), and byte size ($Sz1 = Sz0 = 0$). The DTS bit can have any value. Set MRB for one data transfer by one interrupt ($CHNE = 0, DISEL = 0$). Set the RDR address of the SCI in SAR, the start address of the RAM area where the data will be received in DAR, and 128 (H'0080) in CRA. CRB can be set to any value.
2. Set the start address of the transfer information for an RXI interrupt at the DTC vector address.
3. Set the corresponding bit in DTCER to 1.
4. Set the SCI to the appropriate receive mode. Set the RIE bit in SCR to 1 to enable the receive end (RXI) interrupt. Since the generation of a receive error during the SCI reception operation will disable subsequent reception, the CPU should be enabled to accept receive error interrupts.
5. Each time reception of one byte of data ends on the SCI, the RDRF flag in SSR is set to 1, an RXI interrupt is generated, and the DTC is activated. The receive data is transferred from RDR to RAM by the DTC. DAR is incremented and CRA is decremented. The RDRF flag is automatically cleared to 0.
6. When CRA becomes 0 after the 128 data transfers have ended, the RDRF flag is held at 1, the DTCE bit is cleared to 0, and an RXI interrupt request is sent to the CPU. Termination processing should be performed in the interrupt handling routine.

11.7.2 Chain Transfer

An example of DTC chain transfer is shown in which pulse output is performed using the PPG. Chain transfer can be used to perform pulse output data transfer and PPG output trigger cycle updating. Repeat mode transfer to the PPG's NDR is performed in the first half of the chain transfer, and normal mode transfer to the TPU's TGR in the second half. This is because clearing of the activation source and interrupt generation at the end of the specified number of transfers are restricted to the second half of the chain transfer (transfer when $CHNE = 0$).

1. Perform settings for transfer to the PPG's NDR. Set MRA to source address incrementing (SM1 = 1, SM0 = 0), fixed destination address (DM1 = DM0 = 0), repeat mode (MD1 = 0, MD0 = 1), and word size (Sz1 = 0, Sz0 = 1). Set the source side as a repeat area (DTS = 1). Set MRB to chain transfer mode (CHNE = 1, CHNS = 0, DISEL = 0). Set the data table start address in SAR, the NDRH address in DAR, and the data table size in CRAH and CRAL. CRB can be set to any value.
2. Perform settings for transfer to the TPU's TGR. Set MRA to source address incrementing (SM1 = 1, SM0 = 0), fixed destination address (DM1 = DM0 = 0), normal mode (MD1 = MD0 = 0), and word size (Sz1 = 0, Sz0 = 1). Set the data table start address in SAR, the TGRA address in DAR, and the data table size in CRA. CRB can be set to any value.
3. Locate the TPU transfer information consecutively after the NDR transfer information.
4. Set the start address of the NDR transfer information to the DTC vector address.
5. Set the bit corresponding to the TGIA interrupt in DTCE to 1.
6. Set TGRA as an output compare register (output disabled) with TIOR, and enable the TGIA interrupt with TIER.
7. Set the initial output value in PODR, and the next output value in NDR. Set bits in DDR and NDER for which output is to be performed to 1. Using PCR, select the TPU compare match to be used as the output trigger.
8. Set the CST bit in TSTR to 1, and start the TCNT count operation.
9. Each time a TGRA compare match occurs, the next output value is transferred to NDR and the set value of the next output trigger period is transferred to TGRA. The activation source TGFA flag is cleared.
10. When the specified number of transfers are completed (the TPU transfer CRA value is 0), the TGFA flag is held at 1, the DTCE bit is cleared to 0, and a TGIA interrupt request is sent to the CPU. Termination processing should be performed in the interrupt handling routine.

11.7.3 Chain Transfer when Counter = 0

By executing a second data transfer and performing re-setting of the first data transfer only when the counter value is 0, it is possible to perform 256 or more repeat transfers.

An example is shown in which a 128-kbyte input buffer is configured. The input buffer is assumed to have been set to start at lower address H'0000. Figure 11.16 shows the chain transfer when the counter value is 0.

1. For the first transfer, set the normal transfer mode for input data. Set the fixed transfer source address, $CRA = H'0000$ (65,536 times), $CHNE = 1$, $CHNS = 1$, and $DISEL = 0$.
2. Prepare the upper 8-bit addresses of the start addresses for 65,536-transfer units for the first data transfer in a separate area (in ROM, etc.). For example, if the input buffer is configured at addresses $H'200000$ to $H'21FFFF$, prepare $H'21$ and $H'20$.
3. For the second transfer, set repeat transfer mode (with the source side as the repeat area) for re-setting the transfer destination address for the first data transfer. Use the upper eight bits of DAR in the first transfer information area as the transfer destination. Set $CHNE = DISEL = 0$. If the above input buffer is specified as $H'200000$ to $H'21FFFF$, set the transfer counter to 2.
4. Execute the first data transfer 65536 times by means of interrupts. When the transfer counter for the first data transfer reaches 0, the second data transfer is started. Set the upper eight bits of the transfer source address for the first data transfer to $H'21$. The lower 16 bits of the transfer destination address of the first data transfer and the transfer counter are $H'0000$.
5. Next, execute the first data transfer the 65536 times specified for the first data transfer by means of interrupts. When the transfer counter for the first data transfer reaches 0, the second data transfer is started. Set the upper eight bits of the transfer source address for the first data transfer to $H'20$. The lower 16 bits of the transfer destination address of the first data transfer and the transfer counter are $H'0000$.
6. Steps 4 and 5 are repeated endlessly. As repeat mode is specified for the second data transfer, no interrupt request is sent to the CPU.

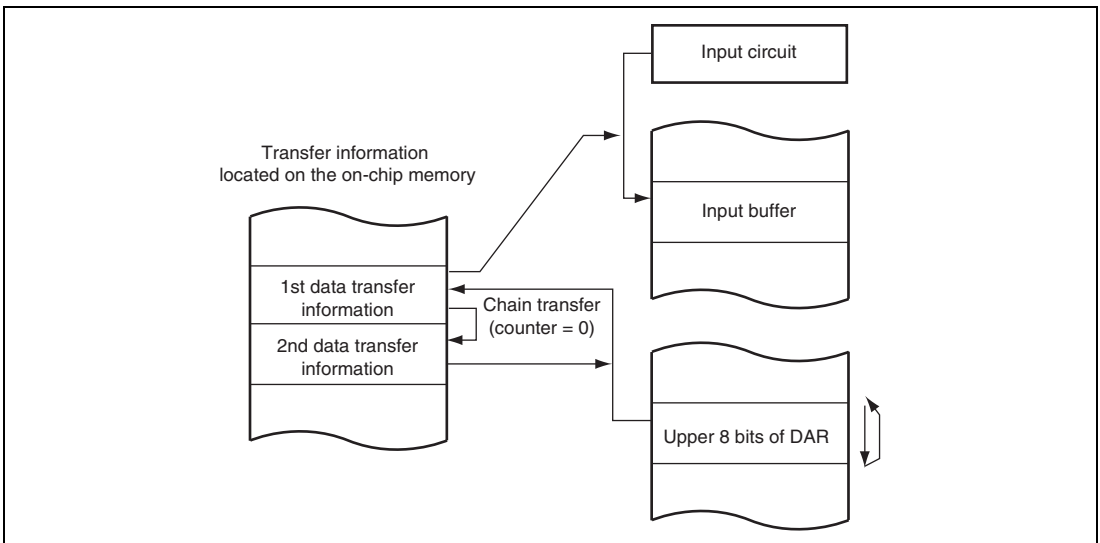

Figure 11.16 Chain Transfer when Counter = 0

11.8 Interrupt Sources

An interrupt request is issued to the CPU when the DTC finishes the specified number of data transfers or a data transfer for which the DISEL bit was set to 1. In the case of interrupt activation, the interrupt set as the activation source is generated. These interrupts to the CPU are subject to CPU mask level and priority level control in the interrupt controller.

11.9 Usage Notes

11.9.1 Module Stop State Setting

Operation of the DTC can be disabled or enabled using the module stop control register. The initial setting is for operation of the DTC to be enabled. Register access is disabled by setting the module stop state. The module stop state cannot be set while the DTC is activated. For details, refer to section 25, Power-Down Modes.

11.9.2 On-Chip RAM

Transfer information can be located in on-chip RAM. In this case, the RAME bit in SYSCR must not be cleared to 0.

11.9.3 DMAC Transfer End Interrupt

When the DTC is activated by a DMAC transfer end interrupt, the DTE bit of DMDR is not controlled by the DTC but its value is modified with the write data regardless of the transfer counter value and DISEL bit setting. Accordingly, even if the DTC transfer counter value becomes 0, no interrupt request may be sent to the CPU in some cases.

When the DTC is activated by a DMAC transfer end interrupt, even if DISEL = 0, an automatic clearing of the relevant activation source flag is not automatically cleared by the DTC. Therefore, write 1 to the DTE bit by the DTC transfer and clear the activation source flag to 0.

11.9.4 DTCE Bit Setting

For DTCE bit setting, use bit manipulation instructions such as BSET and BCLR. If all interrupts are disabled, multiple activation sources can be set at one time (only at the initial setting) by writing data after executing a dummy read on the relevant register.

11.9.5 Chain Transfer

When chain transfer is used, clearing of the activation source or DTCER is performed when the last of the chain of data transfers is executed. At this time, SCI and A/D converter interrupt/activation sources, are cleared when the DTC reads or writes to the relevant register.

Therefore, when the DTC is activated by an interrupt or activation source, if a read/write of the relevant register is not included in the last chained data transfer, the interrupt or activation source will be retained.

11.9.6 Transfer Information Start Address, Source Address, and Destination Address

The transfer information start address to be specified in the vector table should be address $4n$. If an address other than address $4n$ is specified, the lower 2 bits of the address are regarded as 0s.

The source and destination addresses specified in SAR and DAR, respectively, will be transferred in the divided bus cycles depending on the address and data size.

11.9.7 Transfer Information Modification

When $IBCCS = 1$ and the DMAC is used, clear the IBCCS bit to 0 and then set to 1 again before modifying the DTC transfer information in the CPU exception handling routine initiated by a DTC transfer end interrupt.

11.9.8 Endian Format

The DTC supports big and little endian formats. The endian formats used when transfer information is written to and when transfer information is read from by the DTC must be the same.

11.9.9 Points for Caution when Overwriting DTCER

When overwriting of the DTC-transfer enable register (DTCER) and the generation of an interrupt that is a source for DTC activation are in competition, activation of the DTC and interrupt exception processing by the CPU will both proceed at the same time. Depending on the conditions at this time, doubling of interrupts may occur. If there is a possibility of competition between overwriting of the DTCER and generation of an interrupt that is a source for DTC activation, proceed with overwriting of the DTCER according to the relevant procedure given below

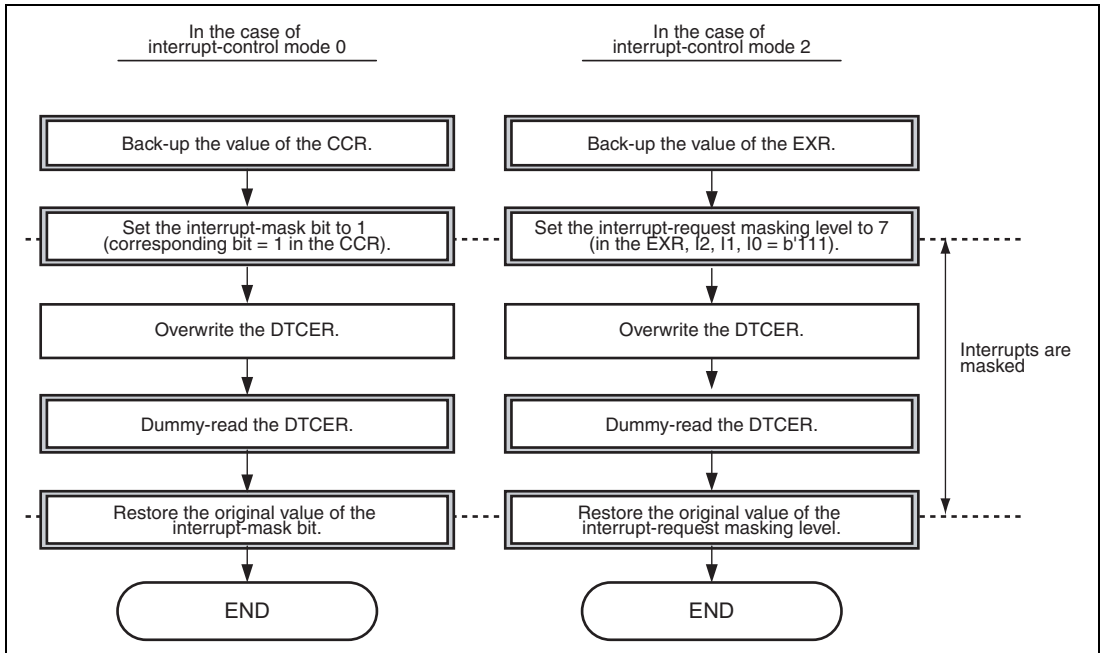

Figure 11.17 Example of Procedures for Overwriting the DTCER

Section 12 I/O Ports

Table 12.1 summarizes the port functions. The pins of each port also have other functions such as input/output pins of on-chip peripheral modules or external interrupt input pins. Each I/O port includes a data direction register (DDR) that controls input/output, a data register (DR) that stores output data, a port register (PORT) used to read the pin states, and an input buffer control register (ICR) that controls input buffer on/off. Port 5 does not have a DR or a DDR register.

Ports D to F and H to K have internal input pull-up MOSs and a pull-up MOS control register (PCR) that controls the on/off state of the input pull-up MOSs.

Ports 2 and F include an open-drain control register (ODR) that controls on/off of the output buffer PMOSs.

All of the I/O ports can drive a single TTL load with a capacitive component of up to 30 pF and drive Darlington transistors when functioning as output ports.

Pins on ports 2, 3, J, and K have Schmitt-trigger inputs. Schmitt-trigger input is enabled for pins of other ports when they are used as IRQ, TPU, TMR, or IIC2 inputs.

Table 12.1 Port Functions

Port	Description	Bit	Function		Schmitt-Trigger Input*1	Input Pull-up MOS Function	Open-Drain Output Function
			I/O	Input			
Port 1	General I/O port function multiplexed with interrupt input, SCI I/O, DMAC I/O, A/D converter input, TPU input, and IIC2 I/O	7	P17/SCL0	$\overline{\text{IRQ7-A}}$ / TCLKD-B/ ADTRG1-A	—	$\overline{\text{IRQ7-A}}$, TCLKD-B, SCL0	—
		6	P16/SDA0/ SCK3	$\overline{\text{IRQ6-A}}$ / TCLKC-B	$\overline{\text{DACK1-A}}$	$\overline{\text{IRQ6-A}}$, TCLKC-B, SDA0	—
		5	P15/SCL1	$\overline{\text{IRQ5-A}}$ / TCLKB-B/ RxD3	$\overline{\text{TEND1-A}}$	$\overline{\text{IRQ5-A}}$, TCLKB-B, SCL1	—
		4	P14/SDA1	$\overline{\text{DREQ1-A}}$ / $\overline{\text{IRQ4-A}}$ / TCLKA-B	TxD3	$\overline{\text{IRQ4-A}}$, TCLKA-B, SDA1	—
		3	P13	ADTRG0-A/ IRQ3-A	—	$\overline{\text{IRQ3-A}}$	—

Port	Description	Bit	Function			Schmitt-Trigger Input * ¹	Input Pull-up MOS Function	Open-Drain Output Function
			I/O	Input	Output			
Port 1	General I/O port function multiplexed with interrupt input, SCI I/O, DMAC I/O, A/D converter input, TPU input, and IIC2 I/O	2	P12/SCK2	$\overline{\text{IRQ2}}\text{-A}$	$\overline{\text{DACK0}}\text{-A}$	$\overline{\text{IRQ2}}\text{-A}$	—	—
		1	P11	RxD2/ $\overline{\text{IRQ1}}\text{-A}$	$\overline{\text{TEND0}}\text{-A}$	$\overline{\text{IRQ1}}\text{-A}$	—	—
		0	P10	$\overline{\text{DREQ0}}\text{-A}/$ $\overline{\text{IRQ0}}\text{-A}$	TxD2	$\overline{\text{IRQ0}}\text{-A}$	—	—
Port 2	General I/O port function multiplexed with interrupt input, PPG output, TPU I/O, TMR I/O, and SCI I/O	7	P27/ TIOCB5	TIOCA5/ $\overline{\text{IRQ15}}\text{-A}$	PO7	All input functions	—	O
		6	P26/ TIOCA5	$\overline{\text{IRQ14}}\text{-A}$	PO6/TMO1/ TxD1	All input functions	—	—
		5	P25/ TIOCA4	TMCI1/ RxD1/ $\overline{\text{IRQ13}}\text{-A}$	PO5	P25, TIOCA4, TMCI1, $\overline{\text{IRQ13}}\text{-A}$	—	—
		4	P24/ TIOCB4/ SCK1	TIOCA4/ TMRI1/ $\overline{\text{IRQ12}}\text{-A}$	PO4	P24, TIOCB4, TIOCA4, TMRI1, $\overline{\text{IRQ12}}\text{-A}$	—	—
		3	P23/ TIOCD3	$\overline{\text{IRQ11}}\text{-A}/$ TIOCC3	PO3	All input functions	—	—
		2	P22/ TIOCC3	$\overline{\text{IRQ10}}\text{-A}$	PO2/TMO0/ TxD0	All input functions	—	—
		1	P21/ TIOCA3	TMCI0/ RxD0/ $\overline{\text{IRQ9}}\text{-A}$	PO1	P21, TIOCA3, TMCI0, $\overline{\text{IRQ9}}\text{-A}$	—	—
		0	P20/ TIOCB3/ SCK0	TIOCA3/ TMRI0/ $\overline{\text{IRQ8}}\text{-A}$	PO0	P20, TIOCB3, TIOCA3, TMRI0, $\overline{\text{IRQ8}}\text{-A}$	—	—

Port	Description	Bit	Function			Schmitt-Trigger Input *1	Input Pull-up MOS Function	Open-Drain Output Function
			I/O	Input	Output			
Port 3	General I/O port function multiplexed with PPG output, DMAC I/O, and TPU I/O	7	P37/ TIOCB2	TIOCA2/ TCLKD-A	PO15	All input functions	—	—
		6	P36/ TIOCA2	—	PO14	All input functions	—	—
		5	P35/ TIOCB1	TIOCA1/ TCLKC-A	PO13/ $\overline{\text{DACK1-B}}$	All input functions	—	—
		4	P34/ TIOCA1	—	PO12/ $\overline{\text{TEND1-B}}$	All input functions	—	—
		3	P33/ TIOCD0	TIOCC0/ $\overline{\text{TCLKB-A/}}$ $\overline{\text{DREQ1-B}}$	PO11	All input functions	—	—
		2	P32/ TIOCC0	TCLKA-A	PO10/ $\overline{\text{DACK0-B}}$	All input functions	—	—
		1	P31/ TIOCB0	TIOCA0	PO9/ $\overline{\text{TEND0-B}}$	All input functions	—	—
		0	P30/ TIOCA0	$\overline{\text{DREQ0-B}}$	PO8	All input functions	—	—
Port 5	General input port function multiplexed with interrupt input, A/D converter input, and D/A converter output	7	—	P57/AN7/ $\overline{\text{IRQ7-B}}$	DA1	$\overline{\text{IRQ7-B}}$	—	—
		6	—	P56/AN6/ $\overline{\text{IRQ6-B}}$	DA0	$\overline{\text{IRQ6-B}}$	—	—
		5	—	P55/AN5/ $\overline{\text{IRQ5-B}}$	—	$\overline{\text{IRQ5-B}}$	—	—
		4	—	P54/AN4/ $\overline{\text{IRQ4-B}}$	—	$\overline{\text{IRQ4-B}}$	—	—
		3	—	P53/AN3/ $\overline{\text{IRQ3-B}}$	—	$\overline{\text{IRQ3-B}}$	—	—
		2	—	P52/AN2/ $\overline{\text{IRQ2-B}}$	—	$\overline{\text{IRQ2-B}}$	—	—
		1	—	P51/AN1/ $\overline{\text{IRQ1-B}}$	—	$\overline{\text{IRQ1-B}}$	—	—
		0	—	P50/AN0/ $\overline{\text{IRQ0-B}}$	—	$\overline{\text{IRQ0-B}}$	—	—

Port	Description	Bit	Function			Schmitt-Trigger Input* ¹	Input Pull-up MOS Function	Open-Drain Output Function
			I/O	Input	Output			
Port 6	General I/O port function multiplexed with TMR I/O, SCI I/O, DMAC I/O, H-UDI input, and interrupt input	5	P65/SCK6	TCK/ $\overline{\text{IRQ13-B}}$	TMO3/ $\overline{\text{DACK3}}$	$\overline{\text{IRQ13-B}}$, TCK	—	—
		4	P64	TMCI3/TDI/ $\overline{\text{IRQ12-B}}$ / RxD6	$\overline{\text{TEND3}}$	TMCI3/ $\overline{\text{IRQ12-B}}$, TDI		
		3	P63	TMRI3/ $\overline{\text{DREQ3}}$ / $\overline{\text{IRQ11-B}}$ / TMS	TxD6	TMRI3, $\overline{\text{IRQ11-B}}$, TMS		
		2	P62/SCK4	$\overline{\text{IRQ10-B}}$ / TRST	TMO2/ $\overline{\text{DACK2}}$	$\overline{\text{IRQ10-B}}$, TRST		
		1	P61	TMCI2/ RxD4/ $\overline{\text{IRQ9-B}}$	$\overline{\text{TEND2}}$	TMCI2, $\overline{\text{IRQ9-B}}$		
		0	P60	TMRI2/ $\overline{\text{DREQ2}}$ / $\overline{\text{IRQ8-B}}$	TxD4	TMRI2, $\overline{\text{IRQ8-B}}$		
Port A	General I/O port function multiplexed with system clock output and bus control I/O	7	—	PA7	B ϕ	—	—	—
		6	PA6	—	$\overline{\text{AS/AH}}$ / $\overline{\text{BS-B}}$			
		5	PA5	—	$\overline{\text{RD}}$			
		4	PA4	—	$\overline{\text{LHWR/LUB}}$			
		3	PA3	—	$\overline{\text{LLWR/LLB}}$			
		2	PA2	—	$\overline{\text{BREQ}}$ / WAIT	—		
		1	PA1	—	BACK/ (RD/WR)			
		0	PA0	—	$\overline{\text{BREQO}}$ / $\overline{\text{BS-A}}$			

Port	Description	Bit	I/O	Function		Schmitt-Trigger Input* ¹	Input Pull-up MOS Function	Open-Drain Output Function
				Input	Output			
Port B	General I/O port function multiplexed with bus control output	3	PB3	—	$\overline{CS3}/\overline{CS7-A}$	—	—	—
		2	PB2	—	$\overline{CS2-A}/\overline{CS6-A}$			
		1	PB1	—	$\overline{CS1}/\overline{CS2-B}/\overline{CS5-A}/\overline{CS6-B}/\overline{CS7-B}$			
		0	PB0	—	$\overline{CS0}/\overline{CS4-A}/\overline{CS5-B}$			
Port D* ³	General I/O port function multiplexed with address output	7	PD7	—	A7	—	O	—
		6	PD6	—	A6			
		5	PD5	—	A5			
		4	PD4	—	A4			
		3	PD3	—	A3			
		2	PD2	—	A2			
		1	PD1	—	A1			
		0	PD0	—	A0			
Port E* ³	General I/O port function multiplexed with address output	7	PE7	—	A15	—	O	—
		6	PE6	—	A14			
		5	PE5	—	A13			
		4	PE4	—	A12			
		3	PE3	—	A11			
		2	PE2	—	A10			
		1	PE1	—	A9			
		0	PE0	—	A8			

Port	Description	Bit	Function			Schmitt-Trigger Input* ¹	Input Pull-up MOS Function	Open-Drain Output Function
			I/O	Input	Output			
Port F	General I/O port function multiplexed with address output, SCI I/O and bus control output	7	PF7/SCK5	—	A23/ CS4-C/ CS5-C/ CS6-C/ CS7-C	—	O	O
		6	PF6	RxD5/IrRxD	A22/CS6-D			
		5	PF5	—	A21/ TxD5/ IrTXD/ CS5-D			
		4	PF4	—	A20			
		3	PF3	—	A19			
		2	PF2	—	A18			
		1	PF1	—	A17			
		0	PF0	—	A16			
		Port H	General I/O port function multiplexed with bi-directional data bus	7	PH7/D7* ²	—	—	—
6	PH6/D6* ²			—	—			
5	PH5/D5* ²			—	—			
4	PH4/D4* ²			—	—			
3	PH3/D3* ²			—	—			
2	PH2/D2* ²			—	—			
1	PH1/D1* ²			—	—			
0	PH0/D0* ²			—	—			
Port I	General I/O port function multiplexed with bi-directional data bus	7	PI7/D15* ²	—	—	—	O	—
		6	PI6/D14* ²	—	—			
		5	PI5/D13* ²	—	—			
		4	PI4/D12* ²	—	—			
		3	PI3/D11* ²	—	—			
		2	PI2/D10* ²	—	—			
		1	PI1/D9* ²	—	—			
		0	PI0/D8* ²	—	—			

Port	Description	Bit	Function			Schmitt-Trigger Input* ¹	Input Pull-up MOS Function	Open-Drain Output Function
			I/O	Input	Output			
Port J* ⁴	General I/O port function multiplexed with PPG and TPU I/O	7	PJ7/ TIOCB8	TIOCA8/ TCLKH	PO23	All input functions	0	—
		6	PJ6/ TIOCA8	—	PO22	All input functions		
		5	PJ5/ TIOCB7	TIOCA7/ TCLKG	PO21	All input functions		
		4	PJ4/ TIOCA7	—	PO20	All input functions		
		3	PJ3/ TIOCD6	TIOCC6/ TCLKF	PO19	All input functions		
		2	PJ2/ TIOCC6	TCLKE	PO18	All input functions		
		1	PJ1/ TIOCB6	TIOCA6	PO17	All input functions		
		0	PJ0/ TIOCA6	—	PO16	All input functions		
Port K* ⁴	General I/O port function multiplexed with PPG and TPU I/O	7	PK7/ TIOCB11	TIOCA11	PO31	All input functions	0	—
		6	PK6/ TIOCA11	—	PO30	All input functions		
		5	PK5/ TIOCB10	TIOCA10	PO29	All input functions		
		4	PK4/ TIOCA10	—	PO28	All input functions		
		3	PK3/ TIOCD9	TIOCC9	PO27	All input functions		
		2	PK2/ TIOCC9	—	PO26	All input functions		
		1	PK1/ TIOCB9	TIOCA9	PO25	All input functions		
		0	PK0/ TIOCA9	—	PO24	All input functions		

- Notes:
1. Pins without Schmitt-trigger input buffer have CMOS input buffer.
 2. Addresses are also output when accessing to the address/data multiplexed I/O space.
 3. Ports D and E are disabled when PCJKE = 1.
 4. Ports J and K are disabled when PCJKE = 0.

12.1 Register Descriptions

Table 12.2 lists each port registers.

Table 12.2 Register Configuration in Each Port

Port	Number of Pins	Registers					
		DDR	DR	PORT	ICR	PCR	ODR
Port 1	8	O	O	O	O	—	—
Port 2	8	O	O	O	O	—	O
Port 3	8	O	O	O	O	—	—
Port 5	8	—	—	O	O	—	—
Port 6	6	O	O	O	O	—	—
Port A	8	O	O	O	O	—	—
Port B	4	O	O	O	O	—	—
Port D* ¹	8	O	O	O	O	O	—
Port E* ¹	8	O	O	O	O	O	—
Port F	8	O	O	O	O	O	O
Port H	8	O	O	O	O	O	—
Port I	8	O	O	O	O	O	—
Port J* ²	8	O	O	O	O	O	—
Port K* ²	8	O	O	O	O	O	—

[Legend]

O: Register exists

—: No register exists

Note: 1. Do not access port D or E registers when PCJKE = 1.
2. Do not access port J or K registers when PCJKE = 0.

12.1.1 Data Direction Register (PnDDR) (n = 1, 2, 3, 6, A, B, D, E, F, and H to K)

DDR is an 8-bit write-only register that specifies the port input or output for each bit. A read from the DDR is invalid and DDR is always read as an undefined value.

When the general I/O port function is selected, the corresponding pin functions as an output port by setting the corresponding DDR bit to 1; the corresponding pin functions as an input port by clearing the corresponding DDR bit to 0.

The initial DDR values are shown in table 12.3.

Bit	7	6	5	4	3	2	1	0
Bit Name	Pn7DDR	Pn6DDR	Pn5DDR	Pn4DDR	Pn3DDR	Pn2DDR	Pn1DDR	Pn0DDR
Initial Value	0	0	0	0	0	0	0	0
R/W	W	W	W	W	W	W	W	W

Notes: The lower 6 bits of port 6 registers are effective while the upper two bits are reserved.
 The lower four bits of port B registers are effective while the upper four bits are reserved.
 Do not access port J or port K registers when PCJKE = 0.
 Do not access port D or port E registers when PCJKE = 1.

Table 12.3 Startup Mode and Initial Value

Port	Startup Mode	
	External Extended Mode	Single-Chip Mode
Port A	H'80	H'00
Other ports	H'00	H'00

12.1.2 Data Register (PnDR) (n = 1, 2, 3, 6, A, B, D, E, F, and H to K)

DR is an 8-bit readable/writable register that stores the output data of the pins to be used as the general output port.

The initial value of DR is H'00.

Bit	7	6	5	4	3	2	1	0
Bit Name	Pn7DR	Pn6DR	Pn5DR	Pn4DR	Pn3DR	Pn2DR	Pn1DR	Pn0DR
Initial Value	0	0	0	0	0	0	0	0
R/W	R/W	R/W	R/W	R/W	R/W	R/W	R/W	R/W

Notes: The lower six bits of port 6 registers are effective while the upper two bits are reserved.
 The lower four bits for port B registers are effective while the upper four bits are reserved.
 Do not access port J or port K registers when PCJKE = 0.
 Do not access port D or port E registers when PCJKE = 1.

12.1.3 Port Register (PORTn) (n = 1, 2, 3, 5, 6, A, B, D, E, F, and H to K)

PORT is an 8-bit read-only register that reflects the port pin state. A write to PORT is invalid. When PORT is read, the DR bits that correspond to the respective DDR bits set to 1 are read and the status of each pin whose corresponding DDR bit is cleared to 0 is also read regardless of the ICR value.

The initial value of PORT is undefined and is determined based on the port pin state.

Bit	7	6	5	4	3	2	1	0
Bit Name	Pn7	Pn6	Pn5	Pn4	Pn3	Pn2	Pn1	Pn0
Initial Value	Undefined	Undefined	Undefined	Undefined	Undefined	Undefined	Undefined	Undefined
R/W	R	R	R	R	R	R	R	R

Notes: The lower six bits of port 6 registers are effective while the upper two bits are reserved.
 The lower four bits for port B registers are effective while the upper four bits are reserved.
 Do not access port J or port K registers when PCJKE = 0.
 Do not access port D or port E registers when PCJKE = 1.

12.1.4 Input Buffer Control Register (PnICR) (n = 1, 2, 3, 5, 6, A, B, D, E, F, and H to K)

ICR is an 8-bit readable/writable register that controls the port input buffers.

For bits in ICR set to 1, the input buffers of the corresponding pins are valid. For bits in ICR cleared to 0, the input buffers of the corresponding pins are invalid and the input signals are fixed high.

When the pin functions as an input for the peripheral modules, the corresponding bits should be set to 1. The initial value should be written to a bit whose corresponding pin is not used as an input or is used as an analog input/output pin.

When PORT is read, the pin state is always read regardless of the ICR value. When the ICR value is cleared to 0 at this time, the read pin state is not reflected in a corresponding on-chip peripheral module.

If ICR is modified, an internal edge may occur depending on the pin state. Accordingly, ICR should be modified when the corresponding input pins are not used. For example, an $\overline{\text{IRQ}}$ input, modify ICR while the corresponding interrupt is disabled, clear the IRQF flag in ISR of the interrupt controller to 0, and then enable the corresponding interrupt. If an edge occurs after the ICR setting, the edge should be cancelled.

The initial value of ICR is H'00.

Bit	7	6	5	4	3	2	1	0
Bit Name	Pn7ICR	Pn6ICR	Pn5ICR	Pn4ICR	Pn3ICR	Pn2ICR	Pn1ICR	Pn0ICR
Initial Value	0	0	0	0	0	0	0	0
R/W	R/W	R/W	R/W	R/W	R/W	R/W	R/W	R/W

Notes: The lower six bits of port 6 registers are effective while the upper two bits are reserved.
 The lower four bits for port B registers are effective while the upper four bits are reserved.
 Do not access port J or port K registers when PCJKE = 0.
 Do not access port D or port E registers when PCJKE = 1.

12.1.5 Pull-Up MOS Control Register (PnPCR) (n = D to F and H to K)

PCR is an 8-bit readable/writable register that controls on/off of the port input pull-up MOS.

If a bit in PCR is set to 1 while the pin is in input state, the input pull-up MOS corresponding to the bit in PCR is turned on. Table 12.4 shows the input pull-up MOS status. The initial value of PCR is H'00.

Bit	7	6	5	4	3	2	1	0
Bit Name	Pn7PCR	Pn6PCR	Pn5PCR	Pn4PCR	Pn3PCR	Pn2PCR	Pn1PCR	Pn0PCR
Initial Value	0	0	0	0	0	0	0	0
R/W	R/W	R/W	R/W	R/W	R/W	R/W	R/W	R/W

Table 12.4 Input Pull-Up MOS State

Port	Pin State	Reset	Hardware Standby Mode	Software Standby Mode	Other Operation
Port D	Address output	OFF	OFF	OFF	OFF
	Port output	OFF	OFF	OFF	OFF
	Port input	OFF	OFF	ON/OFF	ON/OFF
Port E	Address output	OFF	OFF	OFF	OFF
	Port output	OFF	OFF	OFF	OFF
	Port input	OFF	OFF	ON/OFF	ON/OFF
Port F	Address output	OFF	OFF	OFF	OFF
	Peripheral module output	OFF	OFF	OFF	OFF
	Port output	OFF	OFF	OFF	OFF
	Port input	OFF	OFF	ON/OFF	ON/OFF
Port H	Data input/output	OFF	OFF	OFF	OFF
	Port output	OFF	OFF	OFF	OFF
	Port input	OFF	OFF	ON/OFF	ON/OFF
Port I	Data input/output	OFF	OFF	OFF	OFF
	Port output	OFF	OFF	OFF	OFF
	Port input	OFF	OFF	ON/OFF	ON/OFF
Port J	Peripheral module output	OFF	OFF	OFF	OFF
	Port output	OFF	OFF	OFF	OFF
	Port input	OFF	OFF	ON/OFF	ON/OFF

Port	Pin State	Reset	Hardware Standby Mode	Software Standby Mode	Other Operation
Port K	Peripheral module output	OFF	OFF	OFF	OFF
	Port output	OFF	OFF	OFF	OFF
	Port input	OFF	OFF	ON/OFF	ON/OFF

[Legend]

OFF: The input pull-up MOS is always off.

ON/OFF: If PCR is set to 1, the input pull-up MOS is on; if PCR is cleared to 0, the input pull-up MOS is off.

12.1.6 Open-Drain Control Register (PnODR) (n = 2 and F)

ODR is an 8-bit readable/writable register that selects the open-drain output function.

If a bit in ODR is set to 1, the pin corresponding to that bit in ODR functions as an NMOS open-drain output. If a bit in ODR is cleared to 0, the pin corresponding to that bit in ODR functions as a CMOS output.

The initial value of ODR is H'00.

Bit	7	6	5	4	3	2	1	0
Bit Name	Pn7ODR	Pn6ODR	Pn5ODR	Pn4ODR	Pn3ODR	Pn2ODR	Pn1ODR	Pn0ODR
Initial Value	0	0	0	0	0	0	0	0
R/W	R/W	R/W	R/W	R/W	R/W	R/W	R/W	R/W

12.2 Output Buffer Control

This section describes the output priority of each pin.

The name of each peripheral module pin is followed by "_OE". This (for example: TIOCA4_OE) indicates whether the output of the corresponding function is valid (1) or if another setting is specified (0). Table 12.5 lists each port output signal's valid setting. For details on the corresponding output signals, see the register description of each peripheral module. If the name of each peripheral module pin is followed by A or B, the pin function can be modified by the port function control register (PFCR). For details, see section 12.3, Port Function Controller.

For a pin whose initial value changes according to the activation mode, "Initial value E" indicates the initial value when the LSI is started up in external extended mode and "Initial value S" indicates the initial value when the LSI is started in single-chip mode.

12.2.1 Port 1

(1) P17/ $\overline{\text{IRQ7}}$ -A/TCLKD-B/SCL0/ $\overline{\text{ADTRG1}}$ -A

The pin function is switched as shown below according to the combination of the IIC2 register setting and P17DDR bit setting.

Module Name	Pin Function	Setting	
		IIC2	I/O Port
		SCL0_OE	P17DDR
IIC2	SCL0 input/output	1	—
I/O port	P17 output	0	1
	P17 input (initial setting)	0	0

(2) P16/ $\overline{\text{DACK1}}$ -A/ $\overline{\text{IRQ6}}$ -A/TCLKC-B/SDA0/SCK3

The pin function is switched as shown below according to the combination of the DMAC, SCI, and IIC2 register setting and P16DDR bit setting.

Module Name	Pin Function	Setting			
		DMAC	SCI	IIC2	I/O Port
		$\overline{\text{DACK1A}}_{\text{OE}}$	SCK3_OE	SDA0_OE	P16DDR
DMAC	$\overline{\text{DACK1}}$ -A output	1	—	—	—
SCI	SCK3 output	0	1	—	—
IIC2	SDA0 input/output	0	0	1	—
I/O port	P16 output	0	0	0	1
	P16 input (initial setting)	0	0	0	0

(3) P15/RxD3/ $\overline{\text{TEND1-A}}$ / $\overline{\text{IRQ5-A}}$ /TCLKB-B/SCL1

The pin function is switched as shown below according to the combination of the DMAC and IIC2 register setting and P15DDR bit setting.

Module Name	Pin Function	Setting		
		DMAC	IIC2	I/O Port
		$\overline{\text{TEND1A_OE}}$	SCL1_OE	P15DDR
DMAC	$\overline{\text{TEND1-A}}$ output	1	—	—
IIC2	SCL1 input/output	0	1	—
I/O port	P15 output	0	0	1
	P15 input (initial setting)	0	0	0

(4) P14/TxD3/ $\overline{\text{DREQ1-A}}$ / $\overline{\text{IRQ4-A}}$ /TCLKA-B/SDA1

The pin function is switched as shown below according to the combination of the SCI and IIC2 register setting and P14DDR bit setting.

Module Name	Pin Function	Setting		
		SCI	IIC2	I/O Port
		TxD3_OE	SDA1_OE	P14DDR
SCI	TxD3 output	1	—	—
IIC2	SDA1 input/output	0	1	—
I/O port	P14 output	0	0	1
	P14 input (initial setting)	0	0	0

(5) P13/ADTRG0-A/ $\overline{\text{IRQ3}}$ -A

The pin function is switched as shown below according to the P13DDR bit setting.

Module Name	Pin Function	Setting	
		I/O Port	P13DDR
I/O port	P13 output	1	
	P13 input (initial setting)	0	

(6) P12/SCK2/ $\overline{\text{DACK0}}$ -A/ $\overline{\text{IRQ2}}$ -A

The pin function is switched as shown below according to the combination of the DMAC and SCI register settings and P12DDR bit setting.

Module Name	Pin Function	Setting		
		DMAC	SCI	I/O Port
		$\overline{\text{DACK0A}}_{\text{OE}}$	SCK2_OE	P12DDR
DMAC	$\overline{\text{DACK0}}$ -A output	1	—	—
SCI	SCK2 output	0	1	—
I/O port	P12 output	0	0	1
	P12 input (initial setting)	0	0	0

(7) P11/RxD2/ $\overline{\text{TEND0-A}}$ / $\overline{\text{IRQ1-A}}$

The pin function is switched as shown below according to the combination of the DMAC register setting and P11DDR bit setting.

Module Name	Pin Function	Setting	
		DMAC	I/O Port
		$\overline{\text{TEND0A_OE}}$	P11DDR
DMAC	$\overline{\text{TEND0-A}}$ output	1	—
I/O port	P11 output	0	1
	P11 input (initial setting)	0	0

(8) P10/TxD2/ $\overline{\text{DREQ0-A}}$ / $\overline{\text{IRQ0-A}}$

The pin function is switched as shown below according to the combination of the SCI register setting and P10DDR bit setting.

Module Name	Pin Function	Setting	
		SCI	I/O Port
		TxD2_OE	P10DDR
SCI	TxD2 output	1	—
I/O port	P10 output	0	1
	P10 input (initial setting)	0	0

12.2.2 Port 2

(1) P27/PO7/TIOCA5/TIOCB5/ $\overline{\text{IRQ15}}$ -A

The pin function is switched as shown below according to the combination of the TPU and PPG register settings and P27DDR bit setting.

Module Name	Pin Function	Setting		
		TPU	PPG	I/O Port
		TIOCB5_OE	PO7_OE	P27DDR
TPU	TIOCB5 output	1	—	—
PPG	PO7 output	0	1	—
I/O port	P27 output	0	0	1
	P27 input (initial setting)	0	0	0

(2) P26/PO6/TIOCA5/TMO1/TxD1/ $\overline{\text{IRQ14}}$ -A

The pin function is switched as shown below according to the combination of the TPU, TMR, SCI, and PPG register settings and P26DDR bit setting.

Module Name	Pin Function	Setting				
		TPU	TMR	SCI	PPG	I/O Port
		TIOCA5_OE	TMO1_OE	TxD1_OE	PO6_OE	P26DDR
TPU	TIOCA5 output	1	—	—	—	—
TMR	TMO1 output	0	1	—	—	—
SCI	TxD1 output	0	0	1	—	—
PPG	PO6 output	0	0	0	1	—
I/O port	P26 output	0	0	0	0	1
	P26 input (initial setting)	0	0	0	0	0

(3) P25/PO5/TIOCA4/TMC11/RxD1/ $\overline{\text{IRQ13}}$ -A

The pin function is switched as shown below according to the combination of the TPU and PPG register settings and P25DDR bit setting.

Module Name	Pin Function	Setting		
		TPU	PPG	I/O Port
		TIOCA4_OE	PO5_OE	P25DDR
TPU	TIOCA4 output	1	—	—
PPG	PO5 output	0	1	—
I/O port	P25 output	0	0	1
	P25 input (initial setting)	0	0	0

(4) P24/PO4/TIOCA4/TIOCB4/TMRI1/SCK1/ $\overline{\text{IRQ12}}$ -A

The pin function is switched as shown below according to the combination of the TPU, SCI, and PPG register settings and P24DDR bit setting.

Module Name	Pin Function	Setting			
		TPU	SCI	PPG	I/O Port
		TIOCB4_OE	SCK1_OE	PO4_OE	P24DDR
TPU	TIOCB4 output	1	—	—	—
SCI	SCK1 output	0	1	—	—
PPG	PO4 output	0	0	1	—
I/O port	P24 output	0	0	0	1
	P24 input (initial setting)	0	0	0	0

(5) P23/PO3/TIOCC3/TIOCD3/ $\overline{\text{IRQ11}}$ -A

The pin function is switched as shown below according to the combination of the TPU and PPG register settings and P23DDR bit setting.

Module Name	Pin Function	Setting		
		TPU	PPG	I/O Port
		TIOCD3_OE	PO3_OE	P23DDR
TPU	TIOCD3 output	1	—	—
PPG	PO3 output	0	1	—
I/O port	P23 output	0	0	1
	P23 input (initial setting)	0	0	0

(6) P22 /PO2/TIOCC3/TMO0/TxD0/ $\overline{\text{IRQ10}}$ -A

The pin function is switched as shown below according to the combination of the TPU, TMR, SCI, and PPG register settings and P22DDR bit setting.

Module Name	Pin Function	Setting				
		TPU	TMR	SCI	PPG	I/O Port
		TIOCC3_OE	TMO0_OE	TxD0_OE	PO2_OE	P22DDR
TPU	TIOCC3 output	1	—	—	—	—
TMR	TMO0 output	0	1	—	—	—
SCI	TxD0 output	0	0	1	—	—
PPG	PO2 output	0	0	0	1	—
I/O port	P22 output	0	0	0	0	1
	P22 input (initial setting)	0	0	0	0	0

(7) P21/PO1/TIOCA3/TMCI0/RxD0/ $\overline{\text{IRQ9}}$ -A

The pin function is switched as shown below according to the combination of the TPU and PPG register settings and P21DDR bit setting.

Module Name	Pin Function	Setting		
		TPU	PPG	I/O Port
		TIOCA3_OE	PO1_OE	P21DDR
TPU	TIOCA3 output	1	—	—
PPG	PO1 output	0	1	—
I/O port	P21 output	0	0	1
	P21 input (initial setting)	0	0	0

(8) P20/PO0/TIOCA3/TIOCB3/TMRI0/SCK0/ $\overline{\text{IRQ8}}$ -A

The pin function is switched as shown below according to the combination of the TPU, SCI, and PPG register settings and P20DDR bit setting.

Module Name	Pin Function	Setting			
		TPU	SCI	PPG	I/O Port
		TIOCB3_OE	SCK0_OE	PO0_OE	P20DDR
TPU	TIOCB3 output	1	—	—	—
SCI	SCK0 output	0	1	—	—
PPG	PO0 output	0	0	1	—
I/O port	P20 output	0	0	0	1
	P20 input (initial setting)	0	0	0	0

12.2.3 Port 3

(1) P37/PO15/TIOCA2/TIOCB2/TCLKD-A

The pin function is switched as shown below according to the combination of the TPU and PPG register settings and P37DDR bit setting.

Module Name	Pin Function	Setting		
		TPU	PPG	I/O Port
		TIOCB2_OE	PO15_OE	P37DDR
TPU	TIOCB2 output	1	—	—
PPG	PO15 output	0	1	—
I/O port	P37 output	0	0	1
	P37 input (initial setting)	0	0	0

(2) P36/PO14/TIOCA2

The pin function is switched as shown below according to the combination of the TPU and PPG register settings and P36DDR bit setting.

Module Name	Pin Function	Setting		
		TPU	PPG	I/O Port
		TIOCA2_OE	PO14_OE	P36DDR
TPU	TIOCA2 output	1	—	—
PPG	PO14 output	0	1	—
I/O port	P36 output	0	0	1
	P36 input (initial setting)	0	0	0

(3) P35/PO13/TIOCA1/TIOCB1/TCLKC-A/ $\overline{\text{DACK1-B}}$

The pin function is switched as shown below according to the combination of the DMAC, TPU, and PPG register settings and P35DDR bit setting.

Module Name	Pin Function	Setting			
		DMAC $\overline{\text{DACK1B_OE}}$	TPU TIOCB1_OE	PPG PO13_OE	I/O Port P35DDR
DMAC	DACK1-B output	1	—	—	—
TPU	TIOCB1 output	0	1	—	—
PPG	PO13 output	0	0	1	—
I/O port	P35 output	0	0	0	1
	P35 input (initial setting)	0	0	0	0

(4) P34/PO12/TIOCA1/ $\overline{\text{TEND1-B}}$

The pin function is switched as shown below according to the combination of the DMAC, TPU, and PPG register settings and P34DDR bit setting.

Module Name	Pin Function	Setting			
		DMAC $\overline{\text{TEND1B_OE}}$	TPU TIOCA1_OE	PPG PO12_OE	I/O Port P34DDR
DMAC	TEND1-B output	1	—	—	—
TPU	TIOCA1 output	0	1	—	—
PPG	PO12 output	0	0	1	—
I/O port	P34 output	0	0	0	1
	P34 input (initial setting)	0	0	0	0

(5) P33/PO11/TIOCC0/TIOCD0/TCLKB-A/ $\overline{\text{DREQ1}}$ -B

The pin function is switched as shown below according to the combination of the TPU and PPG register settings and P33DDR bit setting.

Module Name	Pin Function	Setting		
		TPU	PPG	I/O Port
		TIOCD0_OE	PO11_OE	P33DDR
TPU	TIOCD0 output	1	—	—
PPG	PO11 output	0	1	—
I/O port	P33 output	0	0	1
	P33 input (initial setting)	0	0	0

(6) P32/PO10/TIOCC0/TCLKA-A/ $\overline{\text{DACK0}}$ -B

The pin function is switched as shown below according to the combination of the DMAC, TPU, and PPG register settings and P32DDR bit setting.

Module Name	Pin Function	Setting			
		DMAC	TPU	PPG	I/O Port
		$\overline{\text{DACK0B}}$ _OE	TIOCC0_OE	PO10_OE	P32DDR
DMAC	$\overline{\text{DACK0}}$ -B output	1	—	—	—
TPU	TIOCC0 output	0	1	—	—
PPG	PO10 output	0	0	1	—
I/O port	P32 output	0	0	0	1
	P32 input (initial setting)	0	0	0	0

(7) P31/PO9/TIOCA0/TIOCB0/ $\overline{\text{TEND0-B}}$

The pin function is switched as shown below according to the combination of the DMAC, TPU, and PPG register settings and P31DDR bit setting.

Module Name	Pin Function	Setting			
		DMAC	TPU	PPG	I/O Port
		$\overline{\text{TEND0B_OE}}$	TIOCB0_OE	PO9_OE	P31DDR
DMAC	$\overline{\text{TEND0-B}}$ output	1	—	—	—
TPU	TIOCB0 output	0	1	—	—
PPG	PO9 output	0	0	1	—
I/O port	P31 output	0	0	0	1
	P31 input (initial setting)	0	0	0	0

(8) P30/PO8/TIOCA0/ $\overline{\text{DREQ0-B}}$

The pin function is switched as shown below according to the combination of the TPU and PPG register settings and P33DDR bit setting.

Module Name	Pin Function	Setting		
		TPU	PPG	I/O Port
		TIOCA0_OE	PO8_OE	P30DDR
TPU	TIOCA0 output	1	—	—
PPG	PO8 output	0	1	—
I/O port	P30 output	0	0	1
	P30 input (initial setting)	0	0	0

12.2.4 Port 5

(1) P57/AN7/DA1/ $\overline{\text{IRQ7}}$ -B

Module Name	Pin Function
-------------	--------------

D/A converter	DA1 output
---------------	------------

(2) P56/AN6/DA0/ $\overline{\text{IRQ6}}$ -B

Module Name	Pin Function
-------------	--------------

D/A converter	DA0 output
---------------	------------

12.2.5 Port 6

(1) P65/TMO3/ $\overline{\text{DACK3}}$ /TCK/SCK6/ $\overline{\text{IRQ13}}$ -B

The pin function is switched as shown below according to the combination of operating mode, the DMAC, TMR, and SCI register settings and P65DDR bit setting.

Module Name	Pin Function	MCU Operating Mode	Setting			
			SCI SCK6_OE	DMAC $\overline{\text{DACK3}}$ _OE	TMR TMO3_OE	I/O Port P65DDR
SCI	SCK6 output	Modes other than the boundary scan enabled mode*	1	—	—	—
DMAC	$\overline{\text{DACK3}}$ output		0	1	—	—
TMR	TMO3 output		0	0	1	—
I/O port	P65 output		0	0	0	1
	P65 input (initial setting)		0	0	0	0

Note: * These pins are boundary scan dedicated input pins during boundary scan enabled mode.

(2) P64/TMCI3/ $\overline{\text{TEND3}}$ /TDI/RxD6/ $\overline{\text{IRQ12}}$ -B

The pin function is switched as shown below according to the combination of operating mode, the DMAC register setting and P64DDR bit setting.

Module Name	Pin Function	MCU Operating Mode	Setting	
			DMAC $\overline{\text{TEND3}}_{\text{OE}}$	I/O Port P64DDR
DMAC	$\overline{\text{TEND3}}$ output	Modes other than the boundary scan enabled mode*	1	—
I/O port	P64 output		0	1
	P64 input (initial setting)		0	0

Note: * These pins are boundary scan dedicated input pins during boundary scan enabled mode.

(3) P63/TMRI3/ $\overline{\text{DREQ3}}$ / $\overline{\text{IRQ11}}$ -B/TxD6/TMS

The pin function is switched as shown below according to the combination of operating mode, the SCI register setting and P63DDR bit setting.

Module Name	Pin Function	MCU Operating Mode	Setting	
			SCI TxD6_OE	I/O Port P63DDR
SCI	TxD6 output	Modes other than the boundary scan enabled mode*	1	—
I/O port	P63 output		0	1
	P63 input (initial setting)		0	0

Note: * These pins are boundary scan dedicated input pins during boundary scan enabled mode.

(4) P62/TMO2/SCK4/DACK2/IRQ10-B/TRST

The pin function is switched as shown below according to the combination of operating mode, the DMAC, TMR, and SCI register settings and P62DDR bit setting.

Module Name	Pin Function	MCU Operating Mode	Setting			
			DMAC	TMR	SCI	I/O Port
			DACK2_OE	TMO2_OE	SCK4_OE	P62DDR
DMAC	DACK2 output	Modes other than the boundary scan enabled mode*	1	—	—	—
TMR	TMO2 output		0	1	—	—
SCI	SCK4 output		0	0	1	—
I/O port	P62 output		0	0	0	1
	P62 input (initial setting)		0	0	0	0

Note: * These pins are boundary scan dedicated input pins during boundary scan enabled mode.

(5) P61/TMCI2/RxD4/TEND2/IRQ9-B

The pin function is switched as shown below according to the combination of the DMAC register setting and P61DDR bit setting.

Module Name	Pin Function	Setting	
		DMAC	I/O Port
		TEND2_OE	P61DDR
DMAC	TEND2 output	1	—
I/O port	P61 output	0	1
	P61 input (initial setting)	0	0

(6) P60/TMRI2/TxD4/DREQ2/IRQ8-B

The pin function is switched as shown below according to the combination of the SCI register setting and P60DDR bit setting.

Module Name	Pin Function	Setting	
		SCI	I/O Port
		TxD4_OE	P60DDR
SCI	TxD4 output	1	—
I/O port	P60 output	0	1
	P60 input (initial setting)	0	0

12.2.6 Port A**(1) PA7/B ϕ**

The pin function is switched as shown below according to the PA7DDR bit setting.

Module Name	Pin Function	Setting
		I/O Port
		PA7DDR
I/O port	B ϕ output (initial setting E)	1
	PA7 input (initial setting S)	0

[Legend]

Initial setting E: Initial setting in external extended mode

Initial setting S: Initial setting in single-chip mode

(2) PA6/ \overline{AS} / \overline{AH} / \overline{BS} -B

The pin function is switched as shown below according to the combination of operating mode, EXPE bit, bus controller register, port function control register (PFCR), and the PA6DDR bit settings.

Module Name	Pin Function	Setting			
		Bus Controller		I/O Port	
		$\overline{AH_OE}$	$\overline{BS-B_OE}$	$\overline{AS_OE}$	PA6DDR
Bus controller	AH output*	1	—	—	—
	\overline{BS} -B output*	0	1	—	—
	\overline{AS} output* (initial setting E)	0	0	1	—
I/O port	PA6 output	0	0	0	1
	PA6 input (initial setting S)	0	0	0	0

[Legend]

Initial setting E: Initial setting in external extended mode

Initial setting S: Initial setting in single-chip mode

Note: * Valid in external extended mode (EXPE = 1)

(3) PA5/ \overline{RD}

The pin function is switched as shown below according to the combination of operating mode, the EXPE bit, and the PA5DDR bit settings.

Module Name	Pin Function	Setting	
		MCU Operating Mode	I/O Port
		EXPE	PA5DDR
Bus controller	\overline{RD} output* (Initial setting E)	1	—
I/O port	PA5 output	0	1
	PA5 input (initial setting S)	0	0

[Legend]

Initial setting E: Initial setting in external extended mode

Initial setting S: Initial setting in single-chip mode

Note: * Valid in external extended mode (EXPE = 1)

(4) PA4/LHWR/LUB

The pin function is switched as shown below according to the combination of operating mode, EXPE bit, bus controller register, port function control register (PFCR), and the PA4DDR bit settings.

Module Name	Pin Function	Setting		
		Bus Controller		I/O Port
		<u>LUB</u> _OE* ²	<u>LHWR</u> _OE* ²	PA4DDR
Bus controller	<u>LUB</u> output* ¹	1	—	—
	<u>LHWR</u> output* ¹ (initial setting E)	—	1	—
I/O port	PA4 output	0	0	1
	PA4 input (initial setting S)	0	0	0

[Legend]

Initial setting E: Initial setting in external extended mode

Initial setting S: Initial setting in single-chip mode

Notes: 1. Valid in external extended mode (EXPE = 1)

2. When the byte control SRAM space is accessed while the byte control SRAM space is specified or while LHWR_OE = 1, this pin functions as the LUB output; otherwise, the LHWR output.

(5) PA3/ $\overline{\text{LLWR}}$ / $\overline{\text{LLB}}$

The pin function is switched as shown below according to the combination of operating mode, EXPE bit, bus controller register, and the PA3DDR bit settings.

Module Name	Pin Function	Setting		
		Bus Controller		I/O Port
		$\overline{\text{LLB}}_{\text{OE}}^{*2}$	$\overline{\text{LLWR}}_{\text{OE}}^{*2}$	PA3DDR
Bus controller	$\overline{\text{LLB}}$ output* ¹	1	—	—
	$\overline{\text{LLWR}}$ output* ¹ (initial setting E)	—	1	—
I/O port	PA3 output	0	0	1
	PA3 input (initial setting S)	0	0	0

[Legend]

Initial setting E: Initial setting in external extended mode

Initial setting S: Initial setting in single-chip mode

Notes: 1. Valid in external extended mode (EXPE = 1)

2. If the byte control SRAM space is accessed, this pin functions as the $\overline{\text{LLB}}$ output; otherwise, the $\overline{\text{LLWR}}$.

(6) PA2/ $\overline{\text{BREQ}}$ / $\overline{\text{WAIT}}$

The pin function is switched as shown below according to the combination of the bus controller register setting and the PA2DDR bit setting.

Module Name	Pin Function	Setting		
		Bus Controller		I/O Port
		BCR_BRLE	BCR_WAITE	PA2DDR
Bus controller	$\overline{\text{BREQ}}$ input	1	—	—
	$\overline{\text{WAIT}}$ input	0	1	—
I/O port	PA2 output	0	0	1
	PA2 input (initial setting)	0	0	0

(7) PA1/ $\overline{\text{BACK}}$ / $\overline{\text{RD}}$ / $\overline{\text{WR}}$

The pin function is switched as shown below according to the combination of operating mode, EXPE bit, bus controller register, port function control register (PFCR), and the PA1DDR bit settings.

Module Name	Pin Function	Setting			
		Bus Controller		I/O Port	
		$\overline{\text{BACK}}_{\text{OE}}$	Byte control SRAM Selection	$\overline{\text{RD}}/\overline{\text{WR}}_{\text{OE}}$	PA1DDR
Bus controller	$\overline{\text{BACK}}$ output *	1	—	—	—
	$\overline{\text{RD}}/\overline{\text{WR}}$ output *	0	1	—	—
		0	0	1	—
I/O port	PA1 output	0	0	0	1
	PA1 input (initial setting)	0	0	0	0

Note: * Valid in external extended mode (EXPE = 1)

(8) PA0/ $\overline{\text{BREQO}}$ / $\overline{\text{BS-A}}$

The pin function is switched as shown below according to the combination of operating mode, EXPE bit, bus controller register, port function control register (PFCR), and the PA0DDR bit settings.

Module Name	Pin Function	Setting		
		I/O Port	Bus Controller	I/O Port
		$\overline{\text{BS-A}}_{\text{OE}}$	$\overline{\text{BREQO}}_{\text{OE}}$	PA0DDR
Bus controller	$\overline{\text{BS-A}}$ output*	1	—	—
	$\overline{\text{BREQO}}$ output*	0	1	—
I/O port	PA0 output	0	0	1
	PA0 input (initial setting)	0	0	0

Note: * Valid in external extended mode (EXPE = 1)

12.2.7 Port B

(1) PB3/ $\overline{\text{CS3}}$ / $\overline{\text{CS7}}$ -A

The pin function is switched as shown below according to the combination of operating mode, EXPE bit, bus controller register, port function control register (PFCR), and the PB3DDR bit settings.

Module Name	Pin Function	Setting		
		Bus Controller		I/O Port
		$\overline{\text{CS3}}_{\text{OE}}$	$\overline{\text{CS7A}}_{\text{OE}}$	PB3DDR
Bus controller	$\overline{\text{CS3}}$ output*	1	—	—
	$\overline{\text{CS7-A}}$ output*	—	1	—
I/O port	PB3 output	0	0	1
	PB3 input (initial setting)	0	0	0

Note: * Valid in external extended mode (EXPE = 1)

(2) PB2/ $\overline{\text{CS2}}$ -A/ $\overline{\text{CS6}}$ -A

The pin function is switched as shown below according to the combination of operating mode, EXPE bit, bus controller register, port function control register (PFCR), and the PB2DDR bit settings.

Module Name	Pin Function	Setting		
		Bus Controller		I/O Port
		$\overline{\text{CS2A}}_{\text{OE}}$	$\overline{\text{CS6A}}_{\text{OE}}$	PB2DDR
Bus controller	$\overline{\text{CS2-A}}$ output*	1	—	—
	$\overline{\text{CS6-A}}$ output*	—	1	—
I/O port	PB2 output	0	0	1
	PB2 input (initial setting)	0	0	0

Note: * Valid in external extended mode (EXPE = 1)

(3) PB1/ $\overline{\text{CS1}}$ / $\overline{\text{CS2-B}}$ / $\overline{\text{CS5-A}}$ / $\overline{\text{CS6-B}}$ / $\overline{\text{CS7-B}}$

The pin function is switched as shown below according to the combination of operating mode, EXPE bit, port function control register (PFCR), and the PB1DDR bit settings.

Module Name	Pin Function	Setting					
		I/O Port					
		$\overline{\text{CS1}}_{\text{OE}}$	$\overline{\text{CS2B}}_{\text{OE}}$	$\overline{\text{CS5A}}_{\text{OE}}$	$\overline{\text{CS6B}}_{\text{OE}}$	$\overline{\text{CS7B}}_{\text{OE}}$	PB1DDR
Bus controller	$\overline{\text{CS1}}$ output*	1	—	—	—	—	—
	$\overline{\text{CS2-B}}$ output*	—	1	—	—	—	—
	$\overline{\text{CS5-A}}$ output*	—	—	1	—	—	—
	$\overline{\text{CS6-B}}$ output*	—	—	—	1	—	—
	$\overline{\text{CS7-B}}$ output*	—	—	—	—	1	—
I/O port	PB1 output	0	0	0	0	0	1
	PB1 input (initial setting)	0	0	0	0	0	0

Note: * Valid in external extended mode (EXPE = 1)

(4) PB0/ $\overline{\text{CS0}}$ / $\overline{\text{CS4-A}}$ / $\overline{\text{CS5-B}}$

The pin function is switched as shown below according to the combination of operating mode, EXPE bit, port function control register (PFCR), and the PB0DDR bit settings.

Module Name	Pin Function	Setting			
		I/O Port			
		$\overline{\text{CS0}}_{\text{OE}}$	$\overline{\text{CS4A}}_{\text{OE}}$	$\overline{\text{CS5B}}_{\text{OE}}$	PB0DDR
Bus controller	$\overline{\text{CS0}}$ output (initial setting E)	1	—	—	—
	$\overline{\text{CS4}}$ output	—	1	—	—
	$\overline{\text{CS5-B}}$ output	—	—	1	—
I/O port	PB0 output	0	0	0	1
	PB0 input (initial setting S)	0	0	0	0

[Legend]

Initial setting E: Initial setting in on-chip ROM disabled external extended mode

Initial setting S: Initial setting in other modes

12.2.8 Port D

The pin function of port D can be switched with that of port J according to the combination of operating mode, the EXPE bit, and the PCJKE bit settings. The pin function of port D can be switched according to the PCJKE bit setting in the single-chip mode (EXPE = 0). However, do not change the setting of the PCJKE bit in external extended mode. For details, see section 12.3.11, Port Function Control Register D (PFCRD).

(1) PD7/A7, PD6/A6, PD5/A5, PD4/A4, PD3/A3, PD2/A2, PD1/A1, PD0/A0

The pin function is switched as shown below according to the combination of operating mode, the EXPE bit, and the PDnDDR bit settings.

Module Name	Pin Function	Setting	
		MCU Operating Mode	I/O Port PDnDDR
Bus controller	Address output	On-chip ROM disabled extended mode	—
		On-chip ROM enabled extended mode	1
I/O port	PDn output	Single-chip mode*	1
	PDn input (initial setting)	Modes other than on-chip ROM disabled extended mode	0

[Legend]

n: 0 to 7

Note: * Address output is enabled by setting PDnDDR = 1 in external extended mode (EXPE = 1)

12.2.9 Port E

The pin function of port E can be switched with that of port K according to the combination of operating mode, the EXPE bit, and the PCJKE bit settings. The pin function of port E can be switched according to the PCJKE bit setting in the single-chip mode (EXPE = 0). However, do not change the setting of the PCJKE bit in external extended mode. For details, see section 12.3.11, Port Function Control Register D (PFCRD).

(1) PE7/A15, PE6/A14, PE5/A13, PE4/A12, PE3/A11, PE2/A10, PE1/A9, PE0/A8

The pin function is switched as shown below according to the combination of operating mode, the EXPE bit, and the PEnDDR bit settings.

Module Name	Pin Function	Setting	
		MCU Operating Mode	I/O Port PEnDDR
Bus controller	Address output	On-chip ROM disabled extended mode	—
		On-chip ROM enabled extended mode	1
I/O port	PEn output	Single-chip mode*	1
	PEn input (initial setting)	Modes other than on-chip ROM disabled extended mode	0

[Legend]

n: 0 to 7

Note: * Address output is enabled by setting PDnDDR = 1 in external extended mode (EXPE = 1)

12.2.10 Port F

(1) PF7/A23/ $\overline{\text{CS4-C}}$ / $\overline{\text{CS5-C}}$ / $\overline{\text{CS6-C}}$ / $\overline{\text{CS7-C}}$ /SCK5

The pin function is switched as shown below according to the combination of port function control register (PFCR), SCI register, and the PF7DDR bit settings.

Module Name	Pin Function	Setting						
		SCI	I/O Port					
		SCK5_OE	A23_OE	$\overline{\text{CS4C}}_{\text{OE}}$	$\overline{\text{CS5C}}_{\text{OE}}$	$\overline{\text{CS6C}}_{\text{OE}}$	$\overline{\text{CS7C}}_{\text{OE}}$	PF7DDR
SCI	SCK5 output	1	—	—	—	—	—	—
Bus controller	A23 output*	0	1	—	—	—	—	—
	$\overline{\text{CS4-C}}$ output*	0	0	1	—	—	—	—
	$\overline{\text{CS5-C}}$ output*	0	0	—	1	—	—	—
	$\overline{\text{CS6-C}}$ output*	0	0	—	—	1	—	—
	$\overline{\text{CS7-C}}$ output*	0	0	—	—	—	1	—
I/O port	PF7 output	0	0	0	0	0	0	1
	PF7 input (Initial setting)	0	0	0	0	0	0	0

Note: * Valid in external extended mode (EXPE = 1)

(2) PF6/A22/ $\overline{\text{CS6-D}}$ /RxD5/IrRXD

The pin function is switched as shown below according to the combination of the port function control register (PFCR), SCI register, and the PF6DDR bit settings.

Module Name	Pin Function	Setting		
		I/O Port		
		A22_OE	$\overline{\text{CS6D}}_{\text{OE}}$	PF6DDR
Bus controller	A22 output*	1	—	—
	$\overline{\text{CS6-D}}$ output*	0	1	—
I/O port	PF6 output	0	0	1
	PF6 input (initial setting)	0	0	0

Note: * Valid in external extended mode (EXPE = 1)

(3) PF5/A21/ $\overline{\text{CS5-D}}$ /TxD5/IrTXD

The pin function is switched as shown below according to the combination of the port function control register (PFCR), SCI register, and the PF5DDR bit settings.

Module Name	Pin Function	Setting				
		SCI		I/O Port		
		TxD5_OE	IrTXD_OE	A21_OE	$\overline{\text{CS5D}}_{\text{OE}}$	PF5DDR
SCI	TxD5 output	1	—	—	—	—
IrDA	IrTXD output	0	1	—	—	—
Bus controller	A21 output*	0	0	1	—	—
I/O port	$\overline{\text{CS5-D}}$ output*	0	0	0	1	—
	PF5 output	0	0	0	0	1
	PF5 input (initial setting)	0	0	0	0	0

Note: * Valid in external extended mode (EXPE = 1)

(4) PF4/A20

The pin function is switched as shown below according to the combination of operating mode, the EXPE bit, port function control register (PFCR), and the PF4DDR bit settings.

MCU Operating Mode	Module Name	Pin Function	Setting	
			I/O Port	I/O Port
			A20_OE	PF4DDR
On-chip ROM disabled extended mode	Bus controller	A20 output	—	—
Modes other than on-chip ROM disabled extended mode	Bus controller	A20 output*	1	—
	I/O port	PF4 output	0	1
		PF4 input (initial setting)	0	0

Note: * Valid in external extended mode (EXPE = 1)

(5) PF3/A19

The pin function is switched as shown below according to the combination of operating mode, the EXPE bit, port function control register (PFCR), and the PF3DDR bit settings.

MCU Operating Mode	Module Name	Pin Function	Setting	
			I/O Port	I/O Port
			A19_OE	PF3DDR
On-chip ROM disabled extended mode	Bus controller	A19 output	—	—
Modes other than on-chip ROM disabled extended mode	Bus controller	A19 output*	1	—
	I/O port	PF3 output	0	1
		PF3 input (initial setting)	0	0

Note: * Valid in external extended mode (EXPE = 1)

(6) PF2/A18

The pin function is switched as shown below according to the combination of operating mode, the EXPE bit, port function control register (PFCR), and the PF2DDR bit settings.

MCU Operating Mode	Module Name	Pin Function	Setting	
			I/O Port	I/O Port
			A18_OE	PF2DDR
On-chip ROM disabled extended mode	Bus controller	A18 output	—	—
Modes other than on-chip ROM disabled extended mode	Bus controller	A18 output*	1	—
	I/O port	PF2 output	0	1
		PF2 input (initial setting)	0	0

Note: * Valid in external extended mode (EXPE = 1)

(7) PF1/A17

The pin function is switched as shown below according to the combination of operating mode, the EXPE bit, port function control register (PFCR), and the PF1DDR bit settings.

MCU Operating Mode	Module Name	Pin Function	Setting	
			I/O Port	I/O Port
			A17_OE	PF1DDR
On-chip ROM disabled extended mode	Bus controller	A17 output	—	—
Modes other than on-chip ROM disabled extended mode	Bus controller	A17 output*	1	—
	I/O port	PF1 output	0	1
		PF1 input (initial setting)	0	0

Note: * Valid in external extended mode (EXPE = 1)

(8) PF0/A16

The pin function is switched as shown below according to the combination of operating mode, the EXPE bit, port function control register (PFCR), and the PF0DDR bit settings.

MCU Operating Mode	Module Name	Pin Function	Setting	
			I/O Port	I/O Port
			A16_OE	PF0DDR
On-chip ROM disabled extended mode	Bus controller	A16 output	—	—
Modes other than on-chip ROM disabled extended mode	Bus controller	A16 output*	1	—
	I/O port	PF0 output	0	1
		PF0 input (initial setting)	0	0

Note: * Valid in external extended mode (EXPE = 1)

12.2.11 Port H

(1) PH7/D7, PH6/D6, PH5/D5, PH4/D4, PH3/D3, PH2/D2, PH1/D1, PH0/D0

The pin function is switched as shown below according to the combination of operating mode, the EXPE bit, and the PHnDDR bit settings.

Module Name	Pin Function	Setting	
		MCU Operating Mode	I/O Port
		EXPE	PHnDDR
Bus controller	Data I/O* (initial setting E)	1	—
I/O port	PHn output	0	1
	PHn input (initial setting S)	0	0

[Legend]

Initial setting E: Initial setting in external extended mode

Initial setting S: Initial setting in single-chip mode

n: 0 to 7

Note: * Valid in external extended mode (EXPE = 1)

12.2.12 Port I

(1) PI7/D15, PI6/D14, PI5/D13, PI4/D12, PI3/D11, PI2/D10, PI1/D9, PI0/D8

The pin function is switched as shown below according to the combination of operating mode, bus mode, the EXPE bit, and the PInDDR bit settings.

Module Name	Pin Function	Setting	
		Bus Controller	I/O Port
		16-Bit Bus Mode	PInDDR
Bus controller	Data I/O* (initial setting E)	1	—
I/O port	PIn output	0	1
	PIn input (initial setting S)	0	0

[Legend]

Initial setting E: Initial setting in external extended mode

Initial setting S: Initial setting in single-chip mode

n: 0 to 7

Note: * Valid in external extended mode (EXPE = 1)

12.2.13 Port J

The pin function of port J can be switched with that of port D according to the combination of operating mode, the EXPE bit, and the PCJKE bit settings. The pin function of port J can be switched according to the PCJKE bit setting in the single-chip mode (EXPE = 0). However, do not change the setting of the PCJKE bit in external extended mode. For details, see section 12.3.11, Port Function Control Register D (PFCRD).

(1) PJ7/TIOCA8/TIOCB8/TCLKH/PO23

The pin function is switched as shown below according to the combination of the PPG register, TPU register, port function control register (PFCR), and PJ7DDR bit settings.

Module Name	Pin Function	Setting		
		PPG	TPU	I/O Port
		PO23_OE	TIOCB8_OE	PD7DDR
PPG	PO23 output*	1	—	—
TPU	TIOCB8 output*	0	1	—
I/O port	PJ7 output*	0	0	1
	PJ7 input*	0	0	0

Note: * Valid when PCJKE = 1

(2) PJ6/TIOCA8/PO22

The pin function is switched as shown below according to the combination of the PPG register, TPU register, port function control register (PFCR), and the PJ6DDR bit settings.

Module Name	Pin Function	Setting		
		PPG	TPU	I/O Port
		PO22_OE	TIOCA8_OE	PJ6DDR
PPG	PO22 output*	1	—	—
TPU	TIOCA8 output*	0	1	—
I/O port	PJ6 output*	0	0	1
	PJ6 input*	0	0	0

Note: * Valid when PCJKE = 1

(3) PJ5/TIOCA7/TIOCB7/TCLKG/PO21

The pin function is switched as shown below according to the combination of the PPG register, TPU register, port function control register (PFCR), and the PJ5DDR bit settings.

Module Name	Pin Function	Setting		
		PPG	TPU	I/O Port
		PO21_OE	TIOCB7_OE	PJ5DDR
PPG	PO21 output*	1	—	—
TPU	TIOCB7 output*	0	1	—
I/O port	PJ5 output*	0	0	1
	PJ5 input*	0	0	0

Note: * Valid when PCJKE = 1

(4) PJ4/TIOCA7/PO20

The pin function is switched as shown below according to the combination of the PPG register, TPU register, port function control register (PFCR), and the PJ4DDR bit settings.

Module Name	Pin Function	Setting		
		PPG	TPU	I/O Port
		PO20_OE	TIOCA7_OE	PJ4DDR
PPG	PO20 output*	1	—	—
TPU	TIOCA7 output*	0	1	—
I/O port	PJ4 output*	0	0	1
	PJ4 input*	0	0	0

Note: * Valid when PCJKE = 1

(5) PJ3/PO19/TIOCC6/TIOCD6/TCLKF

The pin function is switched as shown below according to the combination of the PPG register, TPU register, port function control register (PFCR), and the PJ3DDR bit settings.

Module Name	Pin Function	Setting		
		PPG	TPU	I/O Port
		PO19_OE	TIOCD6_OE	PJ3DDR
PPG	PO19 output*	1	—	—
TPU	TIOCD6 output*	0	1	—
I/O port	PJ3 output*	0	0	1
	PJ3 input*	0	0	0

Note: * Valid when PCJKE = 1

(6) PJ2/PO18/TIOCC6/TCLKE

The pin function is switched as shown below according to the combination of the PPG register, TPU register, port function control register (PFCR), and the PJ2DDR bit settings.

Module Name	Pin Function	Setting		
		PPG	TPU	I/O Port
		PO18_OE	TIOCC6_OE	PJ2DDR
PPG	PO18 output*	1	—	—
TPU	TIOCC6 output*	0	1	—
I/O port	PJ2 output*	0	0	1
	PJ2 input*	0	0	0

Note: * Valid when PCJKE = 1

(7) PJ1/PO17/TIOCA6/TIOCB6

The pin function is switched as shown below according to the combination of the PPG register, TPU register, port function control register (PFCR), and the PJ1DDR bit settings.

Module Name	Pin Function	Setting		
		PPG	TPU	I/O Port
		PO17_OE	TIOCB6_OE	PJ1DDR
PPG	PO17 output*	1	—	—
TPU	TIOCB6 output*	0	1	—
I/O port	PJ1 output*	0	0	1
	PJ1 input*	0	0	0

Note: * Valid when PCJKE = 1

(8) PJ0/PO16/TIOCA6

The pin function is switched as shown below according to the combination of the PPG register, TPU register, port function control register (PFCR), and the PJ0DDR bit settings.

Module Name	Pin Function	Setting		
		PPG	TPU	I/O Port
		PO16_OE	TIOCA6_OE	PJ0DDR
PPG	PO16 output*	1	—	—
TPU	TIOCA6 output*	0	1	—
I/O port	PJ0 output*	0	0	1
	PJ0 input*	0	0	0

Note: * Valid when PCJKE = 1

12.2.14 Port K

The pin function of port K can be switched with that of port E according to the combination of operating mode, the EXPE bit, and the PCJKE bit settings. The pin function of port K can be switched according to the PCJKE bit setting in the single-chip mode (EXPE = 0). However, do not change the setting of the PCJKE bit in external extended mode. For details, see section 12.3.11, Port Function Control Register D (PFCRD).

(1) PK7/PO31/TIOCA11/TIOCB11

The pin function is switched as shown below according to the combination of the PPG register, TPU register, port function control register (PFCR), and the PK7DDR bit settings.

Module Name	Pin Function	Setting		
		PPG	TPU	I/O Port
		PO31_OE	TIOCB11_OE	PK7DDR
PPG	PO31 output*	1	—	—
TPU	TIOCB11 output*	0	1	—
I/O port	PK7 output*	0	0	1
	PK7 input*	0	0	0

Note: * Valid when PCJKE = 1

(2) PK6/PO30/TIOCA11

The pin function is switched as shown below according to the combination of the PPG register, TPU register, port function control register (PFCR), and the PK6DDR bit settings.

Module Name	Pin Function	Setting		
		PPG	TPU	I/O Port
		PO30_OE	TIOCA11_OE	PK6DDR
PPG	PO30 output*	1	—	—
TPU	TIOCA11 output*	0	1	—
I/O port	PK6 output*	0	0	1
	PK6 input*	0	0	0

Note: * Valid when PCJKE = 1

(3) PK5/PO29/TIOCA10/TIOCB10

The pin function is switched as shown below according to the combination of the PPG register, TPU register, port function control register (PFCR), and the PK5DDR bit settings.

Module Name	Pin Function	Setting		
		PPG	TPU	I/O Port
		PO29_OE	TIOCB10_OE	PK5DDR
PPG	PO29 output*	1	—	—
TPU	TIOCB10 output*	0	1	—
I/O port	PK5 output*	0	0	1
	PK5 input*	0	0	0

Note: * Valid when PCJKE = 1

(4) PK4/PO28/TIOCA10

The pin function is switched as shown below according to the combination of the PPG register, TPU register, port function control register (PFCR), and the PK4DDR bit settings.

Module Name	Pin Function	Setting		
		PPG	TPU	I/O Port
		PO28_OE	TIOCA10_OE	PK4DDR
PPG	PO28 output*	1	—	—
TPU	TIOCA10 output*	0	1	—
I/O port	PK4 output*	0	0	1
	PK4 input*	0	0	0

Note: * Valid when PCJKE = 1

(5) PK3/PO27/TIOCC9/TIOCD9

The pin function is switched as shown below according to the combination of the PPG register, TPU register, port function control register (PFCR), and the PK3DDR bit settings.

Module Name	Pin Function	Setting		
		PPG	TPU	I/O Port
		PO27_OE	TIOCD9_OE	PK3DDR
PPG	PO27 output*	1	—	—
TPU	TIOCD9 output*	0	1	—
I/O port	PK3 output*	0	0	1
	PK3 input*	0	0	0

Note: * Valid when PCJKE = 1

(6) PK2/PO26/TIOCC9

The pin function is switched as shown below according to the combination of the PPG register, TPU register, port function control register (PFCR), and the PK2DDR bit settings.

Module Name	Pin Function	Setting		
		PPG	TPU	I/O Port
		PO26_OE	TIOCC9_OE	PK2DDR
PPG	PO26 output*	1	—	—
TPU	TIOCC9 output*	0	1	—
I/O port	PK2 output*	0	0	1
	PK2 input*	0	0	0

Note: * Valid when PCJKE = 1

(7) PK1/PO25/TIOCA9/TIOCB9

The pin function is switched as shown below according to the combination of the PPG register, TPU register, port function control register (PFCR), and the PK1DDR bit settings.

Module Name	Pin Function	Setting		
		PPG	TPU	I/O Port
		PO25_OE	TIOCB9_OE	PK1DDR
PPG	PO25 output*	1	—	—
TPU	TIOCB9 output*	0	1	—
I/O port	PK1 output*	0	0	1
	PK1 input*	0	0	0

Note: * Valid when PCJKE = 1

(8) PK0/PO24/TIOCA9

The pin function is switched as shown below according to the combination of the PPG register, TPU register, port function control register (PFCR), and the PK0DDR bit settings.

Module Name	Pin Function	Setting		
		PPG	TPU	I/O Port
		PO24_OE	TIOCA9_OE	PK0DDR
PPG	PO24 output*	1	—	—
TPU	TIOCA9 output*	0	1	—
I/O port	PK0 output*	0	0	1
	PK0 input*	0	0	0

Note: * Valid when PCJKE = 1

Table 12.5 Available Output Signals and Settings in Each Port

Port	Output Specification Signal Name	Output Signal Name	Signal Selection Register Settings	Peripheral Module Settings
P1	7	SCL0_OE	SCL0	ICCRA.ICE = 1
	6	$\overline{\text{DACK1A_OE}}$	$\overline{\text{DACK1}}$	PF0CR7.DMAS1[A,B] = 00 DMAC.DACR_1.AMS = 1, DMDR_1.DACKE = 1
		SCK3_OE	SCK3	When SCMR.SMIF = 1: SCR.TE = 1 or SCR.RE = 1 while SMR.GM = 0, SCR.CKE[1,0] = 01 or while SMR.GM = 1 When SCMR.SMIF = 0: SCR.TE = 1 or SCR.RE = 1 while SMR.C/A = 0, SCR.CKE[1,0] = 01 or while SMR.C/A = 1, SCR.CKE1 = 0
		SDA0_OE	SDA0	ICCRA.ICE = 1
	5	$\overline{\text{TEND1A_OE}}$	$\overline{\text{TEND1}}$	PF0CR7.DMAS1[A,B] = 00 DMDR_1.TENDE = 1
		SCL1_OE	SCL1	ICCRA.ICE = 1
	4	TxD3_OE	TxD3	SCR.TE = 1
		SDA1_OE	SDA1	ICCRA.ICE = 1
	3	—	—	—
	2	$\overline{\text{DACK0A_OE}}$	$\overline{\text{DACK0}}$	PF0CR7.DMAS0[A,B] = 00 DMAC.DACR_0.AMS = 1, DMDR_0.DACKE = 1
	SCK2_OE	SCK2	When SCMR.SMIF = 1: SCR.TE = 1 or SCR.RE = 1 while SMR.GM = 0, SCR.CKE[1, 0] = 01 or while SMR.GM = 1 When SCMR.SMIF = 0: SCR.TE = 1 or SCR.RE = 1 while SMR.C/A = 0, SCR.CKE[1, 0] = 01 or while SMR.C/A = 1, SCR.CKE1 = 0	
1	$\overline{\text{TEND0A_OE}}$	$\overline{\text{TEND0}}$	PF0CR7.DMAS0[A,B] = 00 DMDR_0.TENDE = 1	
0	TxD2_OE	TxD2	SCR.TE = 1	
P2	7	TIOCB5_OE	TIOCB5	TPU.TIOR_5.IOB3 = 0, TPU.TIOR_5.IOB[1,0] = 01/10/11
		PO7_OE	PO7	NDERL.NDER7 = 1

Port	Output Specification Signal Name	Output Signal Name	Signal Selection Register Settings	Peripheral Module Settings
P2 6	TIOCA5_OE	TIOCA5		TPU.TIOR_5.IOA3 = 0, TPU.TIOR_5.IOA[1,0] = 01/10/11
	TMO1_OE	TMO1		TMR.TCSR_1.OS3,2 = 01/10/11 or TMR.TCSR_1.OS[1,0] = 01/10/11
	TxD1_OE	TxD1		SCR.TE = 1
	PO6_OE	PO6		NDERL.NDER6 = 1
5	TIOCA4_OE	TIOCA4		TPU.TIOR_4.IOA3 = 0, TPU.TIOR_4.IOA[1,0] = 01/10/11
	PO5_OE	PO5		NDERL.NDER5 = 1
4	TIOCB4_OE	TIOCB4		TPU.TIOR_4.IOB3 = 0, TPU.TIOR_4.IOB[1,0] = 01/10/11
	SCK1_OE	SCK1		When SCMR.SMIF = 1: SCR.TE = 1 or SCR.RE = 1 while SMR.GM = 0, SCR.CKE [1, 0] = 01 or while SMR.GM = 1 When SCMR.SMIF = 0: SCR.TE = 1 or SCR.RE = 1 while SMR.C/A = 0, SCR.CKE [1, 0] = 01 or while SMR.C/A = 1, SCR.CKE 1 = 0
	PO4_OE	PO4		NDERL.NDER4 = 1
3	TIOCD3_OE	TIOCD3		TPU.TMDR.BFB = 0, TPU.TIORL_3.IOD3 = 0, TPU.TIORL_3.IOD[1,0] = 01/10/11
	PO3_OE	PO3		NDERL.NDER3 = 1
2	TIOCC3_OE	TIOCC3		TPU.TMDR.BFA = 0, TPU.TIORL_3.IOC3 = 0, TPU.TIORL_3.IOD[1,0] = 01/10/11
	TMO0_OE	TMO0		TMR.TCSR_0.OS[3,2] = 01/10/11 or TMR.TCSR_0.OS[1,0] = 01/10/11
	TxD0_OE	TxD0		SCR.TE = 1
	PO2_OE	PO2		NDERL.NDER2 = 1

Port		Output Specification Signal Name	Output Signal Name	Signal Selection Register Settings	Peripheral Module Settings
P2	1	TIOCA3_OE	TIOCA3		TPU.TIORH_3.IOA3 = 0, TPU.TIORH_3.IOA[1,0] = 01/10/11
		PO1_OE	PO1		NDERL.NDER1 = 1
	0	TIOCB3_OE	TIOCB3		TPU.TIORH_3.IOB3 = 0, TPU.TIORH_3.IOB[1,0] = 01/10/11
		SCK0_OE	SCK0		When SCMR.SMIF = 1: SCR.TE = 1 or SCR.RE = 1 while SMR.GM = 0, SCR.CKE [1, 0] = 01 or while SMR.GM = 1 When SCMR.SMIF = 0: SCR.TE = 1 or SCR.RE = 1 while SMR.C/A = 0, SCR.CKE [1, 0] = 01 or while SMR.C/A = 1, SCR.CKE 1 = 0
		PO0_OE	PO0		NDERL.NDER0 = 1
P3	7	TIOCB2_OE	TIOCB2		TPU.TIOR_2.IOB3 = 0, TPU.TIOR_2.IOB[1,0] = 01/10/11
		PO15_OE	PO15		NDERH.NDER15 = 1
	6	TIOCA2_OE	TIOCA2		TPU.TIOR_2.IOA3 = 0, TPU.TIOR2_.IOA[1,0] = 01/10/11
		PO14_OE	PO14		NDERH.NDER14 = 1
	5	DACK1B_OE	DACK1	PFCR7.DMAS1[A,B] = 01	DMAC.DACR.AMS = 1, DMDR_1.DACKE = 1
		TIOCB1_OE	TIOCB1		TPU.TIOR_1.IOB3 = 0, TPU.TIOR_1.IOB[1,0] = 01/10/11
		PO13_OE	PO13		NDERH.NDER13 = 1
	4	TEND1B_OE	TEND1	PFCR7.DMAS1[A,B] = 01	DMDR_1.TENDE = 1
		TIOCA1_OE	TIOCA1		TPU.TIOR_1.IOA3 = 0, TPU.TIOR_1.IOA[1,0] = 01/10/11
		PO12_OE	PO12		NDERH.NDER12 = 1
3	TIOCD0_OE	TIOCD0		TPU.TMDR.BFB = 0, TPU.TIORL_0.IOD3 = 0, TPU.TIORL_0.IOD[1,0] = 01/10/11	
	PO11_OE	PO11		NDERH.NDER11 = 1	

Port	Output Specification Signal Name	Output Signal Name	Signal Selection Register Settings	Peripheral Module Settings
P3	2	$\overline{\text{DACK0B_OE}}$	$\overline{\text{DACK0}}$	PF _{CR7} .DMAS0[A,B] = 01 DMAC.DACR_0.AMS = 1, DMDR_0.DACKE = 1
		TIOCC0_OE	TIOCC0	TPU.TMDR.BFA = 0, TPU.TIORL_0.IOC3 = 0, TPU.TIORL_0.IOD[1,0] = 01/10/11
		PO10_OE	PO10	NDERH.NDER10 = 1
1		$\overline{\text{TEND0B_OE}}$	$\overline{\text{TEND0}}$	PF _{CR7} .DMAS0[A,B] = 01 DMDR_0.TENDE = 1
		TIOCB0_OE	TIOCB0	TPU.TIORH_0.IOB3 = 0, TPU.TIORH_0.IOB[1,0] = 01/10/11
		PO9_OE	PO9	NDERH.NDER9 = 1
0		TIOCA0_OE	TIOCA0	TPU.TIORH_0.IOA3 = 0, TPU.TIOH_0.IOA[1,0] = 01/10/11
		PO8_OE	PO8	NDERH.NDER8 = 1
P6	5	$\overline{\text{DACK3_OE}}$	$\overline{\text{DACK3}}$	PF _{CR7} .DMAS3[A,B] = 01 DMAC.DACR_3.AMS = 1, DMDR_3.DACKE = 1
		TMO3_OE	TMO3	TMR.TCSR_3.OS[3,2] = 01/10/11 or TMR.TCSR_3.OS[1,0] = 01/10/11
		SCK6_OE	SCK6	When SCMR.SMIF = 1: SCR.TE = 1 or SCR.RE = 1 while SMR.GM = 0, SCR.CKE[1,0] = 01 or while SMR.GM = 1 When SCMR.SMIF = 0: SCR.TE = 1 or SCR.RE = 1 while SMR.C/A = 0, SCR.CKE[1,0] = 01 or while SMR.C/A = 1, SCR.CKE1 = 0
4	$\overline{\text{TEND3_OE}}$	$\overline{\text{TEND3}}$	PF _{CR7} .DMAS3[A,B] = 01 DMDR_3.TENDE = 1	
3	TxD6_OE	TxD6	SCR.TE = 1	
2		$\overline{\text{DACK2_OE}}$	$\overline{\text{DACK2}}$	PF _{CR7} .DMAS2[A,B] = 01 DMAC.DACR_2.AMS = 1, DMDR.DACKE = 1
		TMO2_OE	TMO2	TMR.TCSR_2.OS[3,2] = 01/10/11 or TMR.TCSR_2.OS[1,0] = 01/10/11

Port	Output Specification Signal Name	Output Signal Name	Signal Selection Register Settings	Peripheral Module Settings
P6	2	SCK4_OE	SCK4	When SCMR.SMIF = 1: SCR.TE = 1 or SCR.RE = 1 while SMR.GM = 0, SCR.CKE [1,0] = 01 or while SMR.GM = 1 When SCMR.SMIF = 0: SCR.TE = 1 or SCR.RE = 1 while SMR.C/A = 0, SCR.CKE [1,0] = 01 or while SMR.C/A = 1, SCR.CKE 1 = 0
	1	$\overline{\text{TEND2}}_{\text{OE}}$	$\overline{\text{TEND2}}$	PFCR7.DMAS2[A,B] = 01 DMDR_2.TENDE = 1
	0	TxD4_OE	TxD4	SCR.TE = 1
PA	7	B ϕ _OE	B ϕ	PADDR.PA7DDR = 1
	6	$\overline{\text{AH}}_{\text{OE}}$	$\overline{\text{AH}}$	SYSCR.EXPE = 1, MPXCR.MPXEn (n = 7 to 3) = 1
		$\overline{\text{BSB}}_{\text{OE}}$	$\overline{\text{BS}}$	PFCR2.BSS = 1 SYSCR.EXPE = 1, PFCR2.BSE = 1
		$\overline{\text{AS}}_{\text{OE}}$	$\overline{\text{AS}}$	SYSCR.EXPE = 1, PFCR2.ASOE = 1
	5	$\overline{\text{RD}}_{\text{OE}}$	$\overline{\text{RD}}$	SYSCR.EXPE = 1
	4	$\overline{\text{LUB}}_{\text{OE}}$	$\overline{\text{LUB}}$	SYSCR.EXPE = 1, PFCR6.LHWROE = 1 or SRAMCR.BCSELn = 1
		$\overline{\text{LHWR}}_{\text{OE}}$	$\overline{\text{LHWR}}$	SYSCR.EXPE = 1, PFCR6.LHWROE = 1
	3	$\overline{\text{LLB}}_{\text{OE}}$	$\overline{\text{LLB}}$	SYSCR.EXPE = 1, SRAMCR.BCSELn = 1
		$\overline{\text{LLWR}}_{\text{OE}}$	$\overline{\text{LLWR}}$	SYSCR.EXPE = 1
	2	—	—	—
	1	$\overline{\text{BACK}}_{\text{OE}}$	$\overline{\text{BACK}}$	SYSCR.EXPE = 1, BCR1.BRLE = 1
		(RD/WR)_OE	RD/WR	SYSCR.EXPE = 1, PFCR2.REWRE = 1 or SRAMCR.BCSELn = 1
	0	$\overline{\text{BSA}}_{\text{OE}}$	$\overline{\text{BS}}$	PFCR2.BSS = 0 SYSCR.EXPE = 1, PFCR2.BSE = 1
	$\overline{\text{BREQO}}_{\text{OE}}$	$\overline{\text{BREQO}}$	SYSCR.EXPE = 1, BCR1.BRLE = 1, BCR1.BREQOE = 1	
PB	3	$\overline{\text{CS3}}_{\text{OE}}$	$\overline{\text{CS3}}$	SYSCR.EXPE = 1, PFCR0.CS3E = 1
		$\overline{\text{CS7A}}_{\text{OE}}$	$\overline{\text{CS7}}$	PFCR1.CS7S[A,B] = 00 SYSCR.EXPE = 1, PFCR0.CS7E = 1
	2	$\overline{\text{CS2A}}_{\text{OE}}$	$\overline{\text{CS2}}$	PFCR2.CS2S = 0 SYSCR.EXPE = 1, PFCR0.CS2E = 1
		$\overline{\text{CS6A}}_{\text{OE}}$	$\overline{\text{CS6}}$	PFCR1.CS6S[A,B] = 00 SYSCR.EXPE = 1, PFCR0.CS6E = 1
	1	$\overline{\text{CS1}}_{\text{OE}}$	$\overline{\text{CS1}}$	SYSCR.EXPE = 1, PFCR0.CS1E = 1
		$\overline{\text{CS2B}}_{\text{OE}}$	$\overline{\text{CS2}}$	PFCR2.CS2S = 1 SYSCR.EXPE = 1, PFCR0.CS2E = 1

Port	Output Specification Signal Name	Output Signal Name	Signal Selection Register Settings	Peripheral Module Settings	
PB	1	$\overline{\text{CS5A}}_{\text{OE}}$	$\overline{\text{CS5}}$	PFCR1.CS5S[A,B] = 00	SYSR.EXPE = 1, PFCR0.CS5E = 1
		$\overline{\text{CS6B}}_{\text{OE}}$	$\overline{\text{CS6}}$	PFCR1.CS6S[A,B] = 01	SYSR.EXPE = 1, PFCR0.CS6E = 1
		$\overline{\text{CS7B}}_{\text{OE}}$	$\overline{\text{CS7}}$	PFCR1.CS7S[A,B] = 01	SYSR.EXPE = 1, PFCR0.CS7E = 1
	0	$\overline{\text{CS0}}_{\text{OE}}$	$\overline{\text{CS0}}$		SYSR.EXPE = 1, PFCR0.CS0E = 1
		$\overline{\text{CS4A}}_{\text{OE}}$	$\overline{\text{CS4}}$	PFCR1.CS4S[A,B] = 00	SYSR.EXPE = 1, PFCR0.CS4E = 1
		$\overline{\text{CS5B}}_{\text{OE}}$	$\overline{\text{CS5}}$	PFCR1.CS5S[A,B] = 01	SYSR.EXPE = 1, PFCR0.CS5E = 1
PD	7	A7_OE	A7		SYSR.EXPE = 1, PDDDR.PD7DDR = 1
	6	A6_OE	A6		SYSR.EXPE = 1, PDDDR.PD6DDR = 1
	5	A5_OE	A5		SYSR.EXPE = 1, PDDDR.PD5DDR = 1
	4	A4_OE	A4		SYSR.EXPE = 1, PDDDR.PD4DDR = 1
	3	A3_OE	A3		SYSR.EXPE = 1, PDDDR.PD3DDR = 1
	2	A2_OE	A2		SYSR.EXPE = 1, PDDDR.PD2DDR = 1
	1	A1_OE	A1		SYSR.EXPE = 1, PDDDR.PD1DDR = 1
	0	A0_OE	A0		SYSR.EXPE = 1, PDDDR.PD0DDR = 1
PE	7	A15_OE	A15		SYSR.EXPE = 1, PEDDR.PE7DDR = 1
	6	A14_OE	A14		SYSR.EXPE = 1, PEDDR.PE6DDR = 1
	5	A13_OE	A13		SYSR.EXPE = 1, PEDDR.PE5DDR = 1
	4	A12_OE	A12		SYSR.EXPE = 1, PEDDR.PE4DDR = 1
	3	A11_OE	A11		SYSR.EXPE = 1, PEDDR.PE3DDR = 1
	2	A10_OE	A10		SYSR.EXPE = 1, PEDDR.PE2DDR = 1
	1	A9_OE	A9		SYSR.EXPE = 1, PEDDR.PE1DDR = 1
	0	A8_OE	A8		SYSR.EXPE = 1, PEDDR.PE0DDR = 1
PF	7	A23A_OE	A23		SYSR.EXPE = 1, PFCR4.A23E = 1
		SCK5_OE	SCK5		When SCMR.SMIF = 1: SCR.TE = 1 or SCR.RE = 1 while SMR.GM = 0, SCR.CKE[1,0] = 01 or while SMR.GM = 1 When SCMR.SMIF = 0: SCR.TE = 1 or SCR.RE = 1 while SMR.C/A = 0, SCR.CKE[1,0] = 01 or while SMR.C/A = 1, SCR.CKE1 = 0
		$\overline{\text{CS4C}}_{\text{OE}}$	CS4	PFCR1.CS4S[A,B] = 10	SYSR.EXPE = 1, PFCR0.CS4E = 1
	$\overline{\text{CS5C}}_{\text{OE}}$	CS5	PFCR1.CS5S[A,B] = 10	SYSR.EXPE = 1, PFCR0.CS5E = 1	

Port	Output Specification Signal Name	Output Signal Name	Signal Selection Register Settings	Peripheral Module Settings	
PF	7	$\overline{CS6C_OE}$	$\overline{CS6}$	PFCR1.CS6S[A,B] = 10	SYSCR.EXPE = 1, PFCR0.CS6E = 1
		$\overline{CS7C_OE}$	$\overline{CS7}$	PFCR1.CS7S[A,B] = 10	SYSCR.EXPE = 1, PFCR0.CS7E = 1
	6	A22A_OE	A22		SYSCR.EXPE = 1, PFCR4.A22E = 1
		$\overline{CS6D_OE}$	$\overline{CS6}^{*3}$	PFCR1.CS6S[A,B] = 11	SYSCR.EXPE = 1, PFCR0.CS6E = 1
	5	A21A_OE	A21		SYSCR.EXPE = 1, PFCR4.A21E = 1
		TxD5_OE	TxD5		SCR.TE = 1
		IrTxD_OE	IrTxD		SCR.TE = 1, IrCR.IrE = 1
		$\overline{CS5D_OE}$	$\overline{CS5}^{*3}$	PFCR1.CS5S[A,B] = 11	SYSCR.EXPE = 1, PFCR0.CS5E = 1
	4	A20_OE	A20		SYSCR.EXPE = 1, PFCR4.A20E = 1
	3	A19_OE	A19		SYSCR.EXPE = 1, PFCR4.A19E = 1
	2	A18_OE	A18		SYSCR.EXPE = 1, PFCR4.A18E = 1
	1	A17_OE	A17		SYSCR.EXPE = 1, PFCR4.A17E = 1
0	A16_OE	A16		SYSCR.EXPE = 1, PFCR4.A16E = 1	
PH	7	D7_E	D7		SYSCR.EXPE = 1
	6	D6_E	D6		SYSCR.EXPE = 1
	5	D5_E	D5		SYSCR.EXPE = 1
	4	D4_E	D4		SYSCR.EXPE = 1
	3	D3_E	D3		SYSCR.EXPE = 1
	2	D2_E	D2		SYSCR.EXPE = 1
	1	D1_E	D1		SYSCR.EXPE = 1
	0	D0_E	D0		SYSCR.EXPE = 1
PI	7	D15_E	D15		SYSCR.EXPE = 1, ABWCR.ABW[H,L]n = 01
	6	D14_E	D14		SYSCR.EXPE = 1, ABWCR.ABW[H,L]n = 01
	5	D13_E	D13		SYSCR.EXPE = 1, ABWCR.ABW[H,L]n = 01
	4	D12_E	D12		SYSCR.EXPE = 1, ABWCR.ABW[H,L]n = 01
	3	D11_E	D11		SYSCR.EXPE = 1, ABWCR.ABW[H,L]n = 01
	2	D10_E	D10		SYSCR.EXPE = 1, ABWCR.ABW[H,L]n = 01
	1	D9_E	D9		SYSCR.EXPE = 1, ABWCR.ABW[H,L]n = 01
	0	D8_E	D8		SYSCR.EXPE = 1, ABWCR.ABW[H,L]n = 01

Port	Output Specification Signal Name	Output Signal Name	Signal Selection Register Settings	Peripheral Module Settings
PJ 7	TIOCB8_OE	TIOCB8		TPU.TIOR_8.IOB3 = 0, TPU.TIOR_8.IOB[1,0] = 01/10/11
	PO23_OE	PO23		NDERL_1.NDER23 = 1
6	TIOCA8_OE	TIOCA8		TPU.TIOR_8.IOA3 = 0, TPU.TIOR_8.IOA[1,0] = 01/10/11
	PO22_OE	PO22		NDERL_1.NDER22 = 1
5	TIOCB7_OE	TIOCB7		TPU.TIOR_7.IOB3 = 0, TPU.TIOR_7.IOB[1,0] = 01/10/11
	PO21_OE	PO21		NDERL_1.NDER21 = 1
4	TIOCA7_OE	TIOCA7		TPU.TIOR_7.IOA3 = 0, TPU.TIOR_7.IOA[1,0] = 01/10/11
	PO20_OE	PO20		NDERL_1.NDER20 = 1
3	TIOCD6_OE	TIOCD6		TPU.TMDR_6.BFB = 0, TPU.TIORL_6.IOD3 = 0, TPU.TIORL_6.IOD[1,0] = 01/10/11
	PO19_OE	PO19		NDERL_1.NDER19 = 1
2	TIOCC6_OE	TIOCC6		TPU.TMDR_6.BFA = 0, TPU.TIORL_6.IOC3 = 0, TPU.TIORL_6.IOC[1,0] = 01/10/11
	PO18_OE	PO18		NDERL_1.NDER18 = 1
1	TIOCB6_OE	TIOCB6		TPU.TIORH_6.IOB3 = 0, TPU.TIORH_6.IOB[1,0] = 01/10/11
	PO17_OE	PO17		NDERL_1.NDER17 = 1
0	TIOCA6_OE	TIOCA6		TPU.TIORH_6.IOA3 = 0, TPU.TIORH_6.IOA[1,0] = 01/10/11
	PO16_OE	PO16		NDERL_1.NDER16 = 1

Port	Output Specification Signal Name	Output Signal Name	Signal Selection Register Settings	Peripheral Module Settings
PK 7	TIOCB11_OE	TIOCB11		TPU.TIOR_11.IOB3 = 0, TPU.TIOR_11.IOB[1,0] = 01/10/11
	PO31_OE	PO31		NDERH_1.NDER31 = 1
6	TIOCA11_OE	TIOCA11		TPU.TIOR_11.IOA3 = 0, TPU.TIOR_11.IOA[1,0] = 01/10/11
	PO30_OE	PO30		NDERH_1.NDER30 = 1
5	TIOCB10_OE	TIOCB10		TPU.TIOR_10.IOB3 = 0, TPU.TIOR_10.IOB[1,0] = 01/10/11
	PO29_OE	PO29		NDERH_1.NDER29 = 1
4	TIOCA10_OE	TIOCA10		TPU.TIOR_10.IOA3 = 0, TPU.TIOR_10.IOA[1,0] = 01/10/11
	PO28_OE	PO28		NDERH_1.NDER28 = 1
3	TIOCD9_OE	TIOCD9		TPU.TMDR_9.BFB = 0, TPU.TIORL_9.IOD3 = 0, TPU.TIORL_9.IOD[1,0] = 01/10/11
	PO27_OE	PO27		NDERH_1.NDER27 = 1
2	TIOCC9_OE	TIOCC9		TPU.TMDR_9.BFA = 0, TPU.TIORL_9.IOC3 = 0, TPU.TIORL_9.IOC[1,0] = 01/10/11
	PO26_OE	PO26		NDERH_1.NDER26 = 1
1	TIOCB9_OE	TIOCB9		TPU.TIORH_9.IOB3 = 0, TPU.TIORH_9.IOB[1,0] = 01/10/11
	PO25_OE	PO25		NDERH_1.NDER25 = 1
0	TIOCA9_OE	TIOCA9		TPU.TIORH_9.IOA3 = 0, TPU.TIORH_9.IOA[1,0] = 01/10/11
	PO24_OE	PO24		NDERH_1.NDER24 = 1

12.3 Port Function Controller

The port function controller controls the I/O ports.

The port function controller incorporates the following registers.

- Port function control register 0 (PFCR0)
- Port function control register 1 (PFCR1)
- Port function control register 2 (PFCR2)
- Port function control register 4 (PFCR4)
- Port function control register 6 (PFCR6)
- Port function control register 7 (PFCR7)
- Port function control register 9 (PFCR9)
- Port function control register A (PFCRA)
- Port function control register B (PFCRB)
- Port function control register C (PFCRC)
- Port function control register D (PFCRD)

12.3.1 Port Function Control Register 0 (PFCR0)

PFCR0 enables/disables the \overline{CS} output.

Bit	7	6	5	4	3	2	1	0
Bit Name	CS7E	CS6E	CS5E	CS4E	CS3E	CS2E	CS1E	CS0E
Initial Value	0	0	0	0	0	0	0	Undefined*
R/W	R/W	R/W	R/W	R/W	R/W	R/W	R/W	R/W

Note: * 1 in external extended mode; 0 in other modes.

Bit	Bit Name	Initial Value	R/W	Description
7	CS7E	0	R/W	CS7 to CS0 Enable
6	CS6E	0	R/W	These bits enable/disable the corresponding \overline{CSn} output.
5	CS5E	0	R/W	
4	CS4E	0	R/W	0: Pin functions as I/O port
3	CS3E	0	R/W	1: Pin functions as \overline{CSn} output pin (n = 7 to 0)
2	CS2E	0	R/W	
1	CS1E	0	R/W	
0	CS0E	Undefined*	R/W	

Note: * 1 in external extended mode, 0 in other modes.

12.3.2 Port Function Control Register 1 (PFCR1)

PFCR1 selects the \overline{CS} output pins.

Bit	7	6	5	4	3	2	1	0
Bit Name	CS7SA	CS7SB	CS6SA	CS6SB	CS5SA	CS5SB	CS4SA	CS4SB
Initial Value	0	0	0	0	0	0	0	0
R/W	R/W	R/W	R/W	R/W	R/W	R/W	R/W	R/W

Bit	Bit Name	Initial Value	R/W	Description
7	CS7SA*	0	R/W	$\overline{CS7}$ Output Pin Select
6	CS7SB*	0	R/W	Selects the output pin for $\overline{CS7}$ when $\overline{CS7}$ output is enabled (CS7E = 1) 00: Specifies pin PB3 as $\overline{CS7}$ -A output 01: Specifies pin PB1 as $\overline{CS7}$ -B output 10: Specifies pin PF7 as $\overline{CS7}$ -C output 11: Setting prohibited
5	CS6SA*	0	R/W	$\overline{CS6}$ Output Pin Select
4	CS6SB*	0	R/W	Selects the output pin for $\overline{CS6}$ when $\overline{CS6}$ output is enabled (CS6E = 1) 00: Specifies pin PB2 as $\overline{CS6}$ -A output 01: Specifies pin PB1 as $\overline{CS6}$ -B output 10: Specifies pin PF7 as $\overline{CS6}$ -C output 11: Specifies pin PF6 as $\overline{CS6}$ -D output
3	CS5SA*	0	R/W	$\overline{CS5}$ Output Pin Select
2	CS5SB*	0	R/W	Selects the output pin for $\overline{CS5}$ when $\overline{CS5}$ output is enabled (CS5E = 1) 00: Specifies pin PB1 as $\overline{CS5}$ -A output 01: Specifies pin PB0 as $\overline{CS5}$ -B output 10: Specifies pin PF7 as $\overline{CS5}$ -C output 11: Specifies pin PF5 as $\overline{CS5}$ -D output
1	CS4SA*	0	R/W	$\overline{CS4}$ Output Pin Select
0	CS4SB*	0	R/W	Selects the output pin for $\overline{CS4}$ when $\overline{CS4}$ output is enabled (CS4E = 1) 00: Specifies pin PB0 as $\overline{CS4}$ -A output 01: Setting prohibited 10: Specifies pin PF7 as $\overline{CS4}$ -C output 11: Setting prohibited

Note: * If multiple \overline{CS} outputs are specified to a single pin according to the \overline{CSn} output pin select bits (n = 4 to 7), multiple \overline{CS} signals are output from the pin. For details, see section 9.5.3, Chip Select Signals.

12.3.3 Port Function Control Register 2 (PFCR2)

PFCR2 selects the \overline{CS} output pin, enables/disables bus control I/O, and selects the bus control I/O pins.

Bit	7	6	5	4	3	2	1	0
Bit Name	—	CS2S	BSS	BSE	—	RDWRE	ASOE	—
Initial Value	0	0	0	0	0	0	1	0
R/W	R	R/W	R/W	R/W	R	R/W	R/W	R

Bit	Bit Name	Initial Value	R/W	Description
7	—	0	R	Reserved This bit is always read as 0. The write value should always be 0.
6	CS2S* ¹	0	R/W	$\overline{CS2}$ Output Pin Select Selects the output pin for $\overline{CS2}$ when $\overline{CS2}$ output is enabled (CS2E = 1) 0: Specifies pin PB2 as $\overline{CS2}$ -A output pin 1: Specifies pin PB1 as $\overline{CS2}$ -B output pin
5	BSS	0	R/W	\overline{BS} Output Pin Select Selects the \overline{BS} output pin 0: Specifies pin PA0 as \overline{BS} -A output pin 1: Specifies pin PA6 as \overline{BS} -B output pin
4	BSE	0	R/W	\overline{BS} Output Enable Enables/disables the \overline{BS} output 0: Disables the \overline{BS} output 1: Enables the \overline{BS} output
3	—	0	R	Reserved This bit is always read as 0. The write value should always be 0.
2	RDWRE* ²	0	R/W	RD/ \overline{WR} Output Enable Enables/disables the RD/ \overline{WR} output 0: Disables the RD/ \overline{WR} output 1: Enables the RD/ \overline{WR} output

Bit	Bit Name	Initial Value	R/W	Description
1	ASOE	1	R/W	\overline{AS} Output Enable Enables/disables the \overline{AS} output 0: Specifies pin PA6 as I/O port 1: Specifies pin PA6 as \overline{AS} output pin
0	—	0	R	Reserved This bit is always read as 0. The write value should always be 0.

- Notes:
1. If multiple \overline{CS} outputs are specified to a single pin according to the \overline{CS}_n output pin select bit ($n = 2, 3$), multiple \overline{CS} signals are output from the pin. For details, see section 9.5.3, Chip Select Signals.
 2. If an area is specified as a byte control SDRAM space, the pin functions as $\overline{RD}/\overline{WR}$ output regardless of the \overline{RDWRE} bit value.

12.3.4 Port Function Control Register 4 (PFCR4)

PFCR4 enables or disables the address output.

Bit	7	6	5	4	3	2	1	0
Bit Name	A23E	A22E	A21E	A20E	A19E	A18E	A17E	A16E
Initial Value	0	0	0	0/1*	0/1*	0/1*	0/1*	0/1*
R/W	R/W	R/W	R/W	R/W	R/W	R/W	R/W	R/W

Bit	Bit Name	Initial Value	R/W	Description
7	A23E	0	R/W	Address A23 Enable Enables/disables the address output (A23) 0: Disables the A23 output 1: Enables the A23 output
6	A22E	0	R/W	Address A22 Enable Enables/disables the address output (A22) 0: Disables the A22 output 1: Enables the A22 output

Bit	Bit Name	Initial Value	R/W	Description
5	A21E	0	R/W	Address A21 Enable Enables/disables the address output (A21) 0: Disables the A21 output 1: Enables the A21 output
4	A20E	0/1*	R/W	Address A20 Enable Enables/disables the address output (A20) 0: Disables the A20 output 1: Enables the A20 output
3	A19E	0/1*	R/W	Address A19 Enable Enables/disables the address output (A19) 0: Disables the A19 output 1: Enables the A19 output
2	A18E	0/1*	R/W	Address A18 Enable Enables/disables the address output (A18) 0: Disables the A18 output 1: Enables the A18 output
1	A17E	0/1*	R/W	Address A17 Enable Enables/disables the address output (A17) 0: Disables the A17 output 1: Enables the A17 output
0	A16E	0/1*	R/W	Address A16 Enable Enables/disables the address output (A16) 0: Disables the A16 output 1: Enables the A16 output

Note: * The initial value changes depending on the operating mode.
The initial value is 1 when the on-chip ROM is disabled, and 0 when the on-chip ROM is enabled.

12.3.5 Port Function Control Register 6 (PFCR6)

PFCR6 selects the TPU clock input pin.

Bit	7	6	5	4	3	2	1	0
Bit Name	—	LHWROE	—	—	TCLKS	—	—	—
Initial Value	1	1	1	0	0	0	0	0
R/W	R/W	R/W	R/W	R	R/W	R/W	R/W	R/W

Bit	Bit Name	Initial Value	R/W	Description
7	—	1	R/W	Reserved This bit is always read as 1. The write value should always be 1.
6	LHWROE	1	R/W	$\overline{\text{LHWR}}$ Output Enable Enables/disables $\overline{\text{LHWR}}$ output (valid in external extended mode). 0: Specifies pin PA4 as I/O port 1: Specifies pin PA4 as $\overline{\text{LHWR}}$ output pin
5	—	1	R/W	Reserved This bit is always read as 1. The write value should always be 1.
4	—	0	R	Reserved This is a read-only bit and cannot be modified.
3	TCLKS	0	R/W	TPU External Clock Input Pin Select Selects the TPU external clock input pins. 0: Specifies pins P32, P33, P35, and P37 as external clock input pins. 1: Specifies pins P14 to P17 as external clock input pins.
2 to 0	—	All 0	R/W	Reserved These bits are always read as 0. The write value should always be 0.

12.3.6 Port Function Control Register 7 (PFCR7)

PFCR7 selects the DMAC I/O pins ($\overline{\text{DREQ}}$, $\overline{\text{DACK}}$, and $\overline{\text{TEND}}$).

Bit	7	6	5	4	3	2	1	0
Bit Name	DMAS3A	DMAS3B	DMAS2A	DMAS2B	DMAS1A	DMAS1B	DMAS0A	DMAS0B
Initial Value	0	0	0	0	0	0	0	0
R/W	R/W	R/W	R/W	R/W	R/W	R/W	R/W	R/W

Bit	Bit Name	Initial Value	R/W	Description
7	DMAS3A	0	R/W	DMAC control pin select
6	DMAS3B	0	R/W	Selects the I/O port to control DMAC_3. 00: Setting invalid 01: Specifies pins P63 to P65 as DMAC control pins 10: Setting prohibited 11: Setting prohibited
5	DMAS2A	0	R/W	DMAC control pin select
4	DMAS2B	0	R/W	Selects the I/O port to control DMAC_2. 00: Setting invalid 01: Specifies pins P60 to P62 as DMAC control pins 10: Setting prohibited 11: Setting prohibited
3	DMAS1A	0	R/W	DMAC control pin select
2	DMAS1B	0	R/W	Selects the I/O port to control DMAC_1. 00: Specifies pins P14 to P16 as DMAC control pins 01: Specifies pins P33 to P35 as DMAC control pins 10: Setting prohibited 11: Setting prohibited
1	DMAS0A	0	R/W	DMAC control pin select
0	DMAS0B	0	R/W	Selects the I/O port to control DMAC_0. 00: Specifies pins P10 to P12 as DMAC control pins 01: Specifies pins P30 to P32 as DMAC control pins 10: Setting prohibited 11: Setting prohibited

12.3.7 Port Function Control Register 9 (PFCR9)

PFCR9 selects the multiple functions for the TPU I/O pins.

Bit	7	6	5	4	3	2	1	0
Bit Name	TPUMS5	TPUMS4	TPUMS3A	TPUMS3B	TPUMS2	TPUMS1	TPUMS0A	TPUMS0B
Initial Value	0	0	0	0	0	0	0	0
R/W	R/W	R/W	R/W	R/W	R/W	R/W	R/W	R/W

Bit	Bit Name	Initial Value	R/W	Description
7	TPUMS5	0	R/W	TPU I/O Pin Multiplex Function Select Selects TIOCA5 function 0: Specifies pin P26 as output compare output and input capture 1: Specifies P27 as input capture input and P26 as output compare
6	TPUMS4	0	R/W	TPU I/O Pin Multiplex Function Select Selects TIOCA4 function 0: Specifies P25 as output compare output and input capture 1: Specifies P24 as input capture input and P25 as output compare
5	TPUMS3A	0	R/W	TPU I/O Pin Multiplex Function Select Selects TIOCA3 function 0: Specifies P21 as output compare output and input capture 1: Specifies P20 as input capture input and P21 as output compare
4	TPUMS3B	0	R/W	TPU I/O Pin Multiplex Function Select Selects TIOCC3 function 0: Specifies P22 as output compare output and input capture 1: Specifies P23 as input capture input and P22 as output compare

Bit	Bit Name	Initial Value	R/W	Description
3	TPUMS2	0	R/W	<p>TPU I/O Pin Multiplex Function Select</p> <p>Selects TIOCA2 function</p> <p>0: Specifies P36 as output compare output and input capture</p> <p>1: Specifies P37 as input capture input and P36 as output compare</p>
2	TPUMS1	0	R/W	<p>TPU I/O Pin Multiplex Function Select</p> <p>Selects TIOCA1 function</p> <p>0: Specifies P34 as output compare output and input capture</p> <p>1: Specifies P35 as input capture input and P34 as output compare</p>
1	TPUMS0A	0	R/W	<p>TPU I/O Pin Multiplex Function Select</p> <p>Selects TIOCA0 function</p> <p>0: Specifies P30 as output compare output and input capture</p> <p>1: Specifies P31 as input capture input and P30 as output compare</p>
0	TPUMS0B	0	R/W	<p>TPU I/O Pin Multiplex Function Select</p> <p>Selects TIOCC0 function</p> <p>0: Specifies P32 as output compare output and input capture</p> <p>1: Specifies P33 as input capture input and P32 as output compare</p>

12.3.8 Port Function Control Register A (PFCRA)

PFCRA selects the multiple functions for the TPU (unit 1) I/O pins. Do not access this register because writing to or reading from the bits in this register is not effective when the PCJKE bit in PFCRD is cleared to 0.

Bit	7	6	5	4	3	2	1	0
Bit Name	TPUMS11	TPUMS10	TPUMS9A	TPUMS9B	TPUMS8	TPUMS7	TPUMS6A	TPUMS6B
Initial Value	0	0	0	0	0	0	0	0
R/W	R/W	R/W	R/W	R/W	R/W	R/W	R/W	R/W

Bit	Bit Name	Initial Value	R/W	Description
7	TPUMS11	0	R/W	TPU I/O Pin Multiplex Function Select Selects TIOCA11 function 0: Specifies PK6 as output compare output and input capture 1: Specifies PK7 as input capture input and PK6 as output compare
6	TPUMS10	0	R/W	TPU I/O Pin Multiplex Function Select Selects TIOCA10 function 0: Specifies PK4 as output compare output and input capture 1: Specifies PK5 as input capture input and PK4 as output compare
5	TPUMS9A	0	R/W	TPU I/O Pin Multiplex Function Select Selects TIOCA9 function 0: Specifies PK0 as output compare output and input capture 1: Specifies PK1 as input capture input and PK0 as output compare
4	TPUMS9B	0	R/W	TPU I/O Pin Multiplex Function Select Selects TIOCC9 function 0: Specifies PK2 as output compare output and input capture 1: Specifies PK3 as input capture input and PK2 as output compare

Bit	Bit Name	Initial Value	R/W	Description
3	TPUMS8	0	R/W	TPU I/O Pin Multiplex Function Select Selects TIOCA8 function 0: Specifies PJ6 as output compare output and input capture 1: Specifies PJ7 as input capture input and PJ6 as output compare
2	TPUMS7	0	R/W	TPU I/O Pin Multiplex Function Select Selects TIOCA7 function 0: Specifies PJ4 as output compare output and input capture 1: Specifies PJ5 as input capture input and PJ4 as output compare
1	TPUMS6A	0	R/W	TPU I/O Pin Multiplex Function Select Selects TIOCA6 function 0: Specifies PJ0 as output compare output and input capture 1: Specifies PJ1 as input capture input and PJ0 as output compare
0	TPUMS6B	0	R/W	TPU I/O Pin Multiplex Function Select Selects TIOCC6 function 0: Specifies PJ2 as output compare output and input capture 1: Specifies PJ3 as input capture input and PJ2 as output compare

12.3.9 Port Function Control Register B (PFCRB)

PFCRB selects the input pins for $\overline{\text{IRQ}}14$ to $\overline{\text{IRQ}}8$.

Bit	7	6	5	4	3	2	1	0
Bit Name	—	ITS14*	ITS13	ITS12	ITS11	ITS10	ITS9	ITS8
Initial Value	0	0	0	0	0	0	0	0
R/W	R/W	R/W*	R/W	R/W	R/W	R/W	R/W	R/W

Note: * Supported only by the H8SX/1638L Group.

- H8SX/1638 Group

Bit	Bit Name	Initial Value	R/W	Description
7, 6	—	All 0	R/W	Reserved These bits are always read as 0. The write value should always be 0.

- H8SX/1638L Group

Bit	Bit Name	Initial Value	R/W	Description
7	—	0	R	Reserved These bits are always read as 0. The write value should always be 0.
6	ITS14	0	R/W*	$\overline{\text{LVD}}$ Interrupt / $\overline{\text{IRQ}}14$ Interrupt Select* Selects whether the $\overline{\text{LVD}}$ interrupt or $\overline{\text{IRQ}}14$ interrupt is to be used. 0: Selects pin P26 as $\overline{\text{IRQ}}14$ -A 1: Selects LVD interrupt
5	ITS13	0	R/W	$\overline{\text{IRQ}}13$ Pin Select Selects an input pin for $\overline{\text{IRQ}}13$. 0: Selects pin P25 as $\overline{\text{IRQ}}13$ -A input 1: Selects pin P65 as $\overline{\text{IRQ}}13$ -B input

Bit	Bit Name	Initial Value	R/W	Description
4	ITS12	0	R/W	<p>$\overline{\text{IRQ12}}$ Pin Select</p> <p>Selects an input pin for $\overline{\text{IRQ12}}$.</p> <p>0: Selects pin P24 as $\overline{\text{IRQ12}}$-A input</p> <p>1: Selects pin P64 as $\overline{\text{IRQ12}}$-B input</p>
3	ITS11	0	R/W	<p>$\overline{\text{IRQ11}}$ Pin Select</p> <p>Selects an input pin for $\overline{\text{IRQ11}}$.</p> <p>0: Selects pin P23 as $\overline{\text{IRQ11}}$-A input</p> <p>1: Selects pin P63 as $\overline{\text{IRQ11}}$-B input</p>
2	ITS10	0	R/W	<p>$\overline{\text{IRQ10}}$ Pin Select</p> <p>Selects an input pin for $\overline{\text{IRQ10}}$.</p> <p>0: Selects pin P22 as $\overline{\text{IRQ10}}$-A input</p> <p>1: Selects pin P62 as $\overline{\text{IRQ10}}$-B input</p>
1	ITS9	0	R/W	<p>$\overline{\text{IRQ9}}$ Pin Select</p> <p>Selects an input pin for $\overline{\text{IRQ9}}$.</p> <p>0: Selects pin P21 as $\overline{\text{IRQ9}}$-A input</p> <p>1: Selects pin P61 as $\overline{\text{IRQ9}}$-B input</p>
0	ITS8	0	R/W	<p>$\overline{\text{IRQ8}}$ Pin Select</p> <p>Selects an input pin for $\overline{\text{IRQ8}}$.</p> <p>0: Selects pin P20 as $\overline{\text{IRQ8}}$-A input</p> <p>1: Selects pin P60 as $\overline{\text{IRQ8}}$-B input</p>

Note: * Supported only by the H8SX/1638L Group.

12.3.10 Port Function Control Register C (PFCRC)

PFCRC selects input pins for $\overline{\text{IRQ7}}$ to $\overline{\text{IRQ0}}$.

Bit	7	6	5	4	3	2	1	0
Bit Name	ITS7	ITS6	ITS5	ITS4	ITS3	ITS2	ITS1	ITS0
Initial Value	0	0	0	0	0	0	0	0
R/W	R/W	R/W	R/W	R/W	R/W	R/W	R/W	R/W

Bit	Bit Name	Initial Value	R/W	Description
7	ITS7	0	R/W	$\overline{\text{IRQ7}}$ Pin Select Selects an input pin for $\overline{\text{IRQ7}}$. 0: Selects pin P17 as $\overline{\text{IRQ7}}$ -A input 1: Selects pin P57 as $\overline{\text{IRQ7}}$ -B input
6	ITS6	0	R/W	$\overline{\text{IRQ6}}$ Pin Select Selects an input pin for $\overline{\text{IRQ6}}$. 0: Selects pin P16 as $\overline{\text{IRQ6}}$ -A input 1: Selects pin P56 as $\overline{\text{IRQ6}}$ -B input
5	ITS5	0	R/W	$\overline{\text{IRQ5}}$ Pin Select Selects an input pin for $\overline{\text{IRQ5}}$. 0: Selects pin P15 as $\overline{\text{IRQ5}}$ -A input 1: Selects pin P55 as $\overline{\text{IRQ5}}$ -B input
4	ITS4	0	R/W	$\overline{\text{IRQ4}}$ Pin Select Selects an input pin for $\overline{\text{IRQ4}}$. 0: Selects pin P14 as $\overline{\text{IRQ4}}$ -A input 1: Selects pin P54 as $\overline{\text{IRQ4}}$ -B input
3	ITS3	0	R/W	$\overline{\text{IRQ3}}$ Pin Select Selects an input pin for $\overline{\text{IRQ3}}$. 0: Selects pin P13 as $\overline{\text{IRQ3}}$ -A input 1: Selects pin P53 as $\overline{\text{IRQ3}}$ -B input
2	ITS2	0	R/W	$\overline{\text{IRQ2}}$ Pin Select Selects an input pin for $\overline{\text{IRQ2}}$. 0: Selects pin P12 as $\overline{\text{IRQ2}}$ -A input 1: Selects pin P52 as $\overline{\text{IRQ2}}$ -B input

Bit	Bit Name	Initial Value	R/W	Description
1	ITS1	0	R/W	$\overline{\text{IRQ1}}$ Pin Select Selects an input pin for $\overline{\text{IRQ1}}$. 0: Selects pin P11 as $\overline{\text{IRQ1}}$ -A input 1: Selects pin P51 as $\overline{\text{IRQ1}}$ -B input
0	ITS0	0	R/W	$\overline{\text{IRQ0}}$ Pin Select Selects an input pin for $\overline{\text{IRQ0}}$. 0: Selects pin P10 as $\overline{\text{IRQ0}}$ -A input 1: Selects pin P50 as $\overline{\text{IRQ0}}$ -B input

12.3.11 Port Function Control Register D (PFCRD)

PFCRD enables or disables the port J and port K pin functions.

Bit	7	6	5	4	3	2	1	0
Bit Name	PCJKE	—	—	—	—	—	—	—
Initial Value	0	0	0	0	0	0	0	0
R/W	R/W	R/W	R/W	R/W	R/W	R/W	R/W	R/W

Bit	Bit Name	Initial Value	R/W	Description
7	PCJKE*	0	R/W	Ports J and K Enable Enables or disables the port J and K pin functions. 0: Ports J and K are disabled. 1: Port s J and K are enabled (ports D and E are disabled).
6 to 0	—	0	R/W	Reserved These bits are always read as 0 and cannot be modified. The initial value should not be changed.

Note: * This bit is only effective in single-chip mode. In other modes, do not change the initial value of this bit.

12.4 Usage Notes

12.4.1 Notes on Input Buffer Control Register (ICR) Setting

1. When the ICR setting is changed, the LSI may malfunction due to an edge occurred internally according to the pin state. Before changing the ICR setting, fix the pin state high or disable the input function corresponding to the pin by the on-chip peripheral module settings.
2. If an input is enabled by setting ICR while multiple input functions are assigned to the pin, the pin state is reflected in all the inputs. Care must be taken for each module settings for unused input functions.
3. When a pin is used as an output, data to be output from the pin will be latched as the pin state if the input function corresponding to the pin is enabled. To use the pin as an output, disable the input function for the pin by setting ICR.

12.4.2 Notes on Port Function Control Register (PFCR) Settings

1. Port function controller controls the I/O port.
Before enabling a port function, select the input/output destination.
2. When changing input pins, this LSI may malfunction due to the internal edge generated by the pin level difference before and after the change.
 - To change input pins, the following procedure must be performed.
 - A. Disable the input function by the corresponding on-chip peripheral module settings
 - B. Select another input pin by PFCR
 - C. Enable its input function by the corresponding on-chip peripheral module settings
3. If a pin function has both a select bit that modifies the input/output destination and an enable bit that enables the pin function, first specify the input/output destination by the selection bit and then enable the pin function by the enable bit.
4. The value of the PCJKE bit must be set during the initial setting immediately after a power-on. Set the PCJKE bit first and then set other bits in PFCR as required.
5. Do not change the value of the PCJKE bit once it has been set.

Section 13 16-Bit Timer Pulse Unit (TPU)

This LSI has two on-chip 16-bit timer pulse units (TPU), unit 0 and unit 1, each comprises six channels. Therefore, this LSI includes twelve channels.

Functions of unit 0 and unit 1 are shown in table 13.1 and table 13.2 respectively. Block diagrams of unit 0 and unit 1 are shown in Figure 13.1 and Figure 13.2 respectively.

This section explains unit 0. This explanation is common to unit 1.

13.1 Features

- Maximum 16-pulse input/output
- Selection of eight counter input clocks for each channel
- The following operations can be set for each channel:
 - Waveform output at compare match
 - Input capture function
 - Counter clear operation
 - Synchronous operations:
 - Multiple timer counters (TCNT) can be written to simultaneously
 - Simultaneous clearing by compare match and input capture possible
 - Simultaneous input/output for registers possible by counter synchronous operation
 - Maximum of 15-phase PWM output possible by combination with synchronous operation
- Buffer operation settable for channels 0 and 3
- Phase counting mode settable independently for each of channels 1, 2, 4, and 5
- Cascaded operation
- Fast access via internal 16-bit bus
- 26 interrupt sources
- Automatic transfer of register data
- Programmable pulse generator (PPG) output trigger can be generated (unit 0 only)
- Conversion start trigger for the A/D converter can be generated (unit 0 only)
- Module stop state can be set

Table 13.1 TPU (Unit 0) Functions

Item		Channel 0	Channel 1	Channel 2	Channel 3	Channel 4	Channel 5
Count clock		P ϕ /1	P ϕ /1	P ϕ /1	P ϕ /1	P ϕ /1	P ϕ /1
		P ϕ /4	P ϕ /4	P ϕ /4	P ϕ /4	P ϕ /4	P ϕ /4
		P ϕ /16	P ϕ /16	P ϕ /16	P ϕ /16	P ϕ /16	P ϕ /16
		P ϕ /64	P ϕ /64	P ϕ /64	P ϕ /64	P ϕ /64	P ϕ /64
		TCLKA	P ϕ /256	P ϕ /1024	P ϕ /256	P ϕ /1024	P ϕ /256
		TCLKB	TCLKA	TCLKA	P ϕ /1024	TCLKA	TCLKA
		TCLKC	TCLKB	TCLKB	P ϕ /4096	TCLKC	TCLKC
	TCLKD		TCLKC	TCLKA		TCLKD	
General registers (TGR)		TGRA_0	TGRA_1	TGRA_2	TGRA_3	TGRA_4	TGRA_5
		TGRB_0	TGRB_1	TGRB_2	TGRB_3	TGRB_4	TGRB_5
General registers/ buffer registers		TGRC_0	—	—	TGRC_3	—	—
		TGRD_0			TGRD_3		
I/O pins		TIOCA0	TIOCA1	TIOCA2	TIOCA3	TIOCA4	TIOCA5
		TIOCB0	TIOCB1	TIOCB2	TIOCB3	TIOCB4	TIOCB5
		TIOCC0			TIOCC3		
		TIOCD0			TIOCD3		
Counter clear function		TGR	TGR	TGR	TGR	TGR	TGR
		compare	compare	compare	compare	compare	compare
		match or	match or	match or	match or	match or	match or
		input	input	input	input	input	input
		capture	capture	capture	capture	capture	capture
		capture	capture	capture	capture	capture	capture
		capture	capture	capture	capture	capture	capture
Compare match output	0 output	O	O	O	O	O	O
	1 output	O	O	O	O	O	O
	Toggle output	O	O	O	O	O	O
Input capture function	O	O	O	O	O	O	
Synchronous operation	O	O	O	O	O	O	
PWM mode	O	O	O	O	O	O	
Phase counting mode	—	O	O	—	O	O	
Buffer operation	O	—	—	O	—	—	
DTC activation		TGR	TGR	TGR	TGR	TGR	TGR
		compare	compare	compare	compare	compare	compare
		match or	match or	match or	match or	match or	match or
		input	input	input	input	input	input
		capture	capture	capture	capture	capture	capture
		capture	capture	capture	capture	capture	capture
		capture	capture	capture	capture	capture	capture

Item	Channel 0	Channel 1	Channel 2	Channel 3	Channel 4	Channel 5
DMAC activation	TGRA_0 compare match or input capture	TGRA_1 compare match or input capture	TGRA_2 compare match or input capture	TGRA_3 compare match or input capture	TGRA_4 compare match or input capture	TGRA_5 compare match or input capture
A/D conversion start trigger	TGRA_0 compare match or input capture	TGRA_1 compare match or input capture	TGRA_2 compare match or input capture	TGRA_3 compare match or input capture	TGRA_4 compare match or input capture	TGRA_5 compare match or input capture
PPG trigger	TGRA_0/ TGRB_0 compare match or input capture	TGRA_1/ TGRB_1 compare match or input capture	TGRA_2/ TGRB_2 compare match or input capture	TGRA_3/ TGRB_3 compare match or input capture	—	—
Interrupt sources	5 sources Compare match or input capture 0A Compare match or input capture 0B Compare match or input capture 0C Compare match or input capture 0D Overflow	4 sources Compare match or input capture 1A Compare match or input capture 1B Overflow Underflow	4 sources Compare match or input capture 2A Compare match or input capture 2B Overflow Underflow	5 sources Compare match or input capture 3A Compare match or input capture 3B Compare match or input capture 3C Compare match or input capture 3D Overflow	4 sources Compare match or input capture 4A Compare match or input capture 4B Overflow Underflow	4 sources Compare match or input capture 5A Compare match or input capture 5B Overflow Underflow

[Legend]

○: Possible

—: Not possible

Table 13.2 TPU (Unit 1) Functions

Item		Channel 6	Channel 7	Channel 8	Channel 9	Channel 10	Channel 11
Count clock		P ϕ /1	P ϕ /1	P ϕ /1	P ϕ /1	P ϕ /1	P ϕ /1
		P ϕ /4	P ϕ /4	P ϕ /4	P ϕ /4	P ϕ /4	P ϕ /4
		P ϕ /16	P ϕ /16	P ϕ /16	P ϕ /16	P ϕ /16	P ϕ /16
		P ϕ /64	P ϕ /64	P ϕ /64	P ϕ /64	P ϕ /64	P ϕ /64
		TCLKE	P ϕ /256	P ϕ /1024	P ϕ /256	P ϕ /1024	P ϕ /256
		TCLKF	TCLKE	TCLKE	P ϕ /1024	TCLKE	TCLKE
		TCLKG	TCLKF	TCLKF	P ϕ /4096	TCLKG	TCLKG
	TCLKH		TCLKG	TCLKE		TCLKH	
General registers (TGR)		TGRA_6	TGRA_7	TGRA_8	TGRA_9	TGRA_10	TGRA_11
		TGRB_6	TGRB_7	TGRB_8	TGRB_9	TGRB_10	TGRB_11
General registers/ buffer registers		TGRC_6	—	—	TGRC_9	—	—
		TGRD_6			TGRD_9		
I/O pins		TIOCA6	TIOCA7	TIOCA8	TIOCA9	TIOCA10	TIOCA11
		TIOCB6	TIOCB7	TIOCB8	TIOCB9	TIOCB10	TIOCB11
		TIOCC6			TIOCC9		
		TIOCD6			TIOCD9		
Counter clear function		TGR	TGR	TGR	TGR	TGR	TGR
		compare match or input capture	compare match or input capture	compare match or input capture	compare match or input capture	compare match or input capture	compare match or input capture
Compare match output	0 output	O	O	O	O	O	O
	1 output	O	O	O	O	O	O
	Toggle output	O	O	O	O	O	O
Input capture function	O	O	O	O	O	O	
Synchronous operation	O	O	O	O	O	O	
PWM mode	O	O	O	O	O	O	
Phase counting mode	—	O	O	—	O	O	
Buffer operation	O	—	—	O	—	—	
DTC activation		TGR	TGR	TGR	TGR	TGR	TGR
		compare match or input capture	compare match or input capture	compare match or input capture	compare match or input capture	compare match or input capture	compare match or input capture

Item	Channel 6	Channel 7	Channel 8	Channel 9	Channel 10	Channel 11
DMAC activation	TGRA_6 compare match or input capture	TGRA_7 compare match or input capture	TGRA_8 compare match or input capture	TGRA_9 compare match or input capture	TGRA_10 compare match or input capture	TGRA_11 compare match or input capture
A/D conversion start trigger	—	—	—	—	—	—
PPG trigger	TGRA_6/ TGRB_6 compare match	TGRA_7/ TGRB_7 compare match	TGRA_8/ TGRB_8 compare match	TGRA_9/ TGRB_9 compare match	—	—
Interrupt sources	5 sources Compare match or input capture 6A Compare match or input capture 6B Compare match or input capture 6C Compare match or input capture 6D Overflow	4 sources Compare match or input capture 7A Compare match or input capture 7B Overflow Underflow	4 sources Compare match or input capture 8A Compare match or input capture 8B Overflow Underflow	5 sources Compare match or input capture 9A Compare match or input capture 9B Compare match or input capture 9C Compare match or input capture 9D Overflow	4 sources Compare match or input capture 10A Compare match or input capture 10B Overflow Underflow	4 sources Compare match or input capture 11A Compare match or input capture 11B Overflow Underflow

[Legend]

○: Possible

—: Not possible

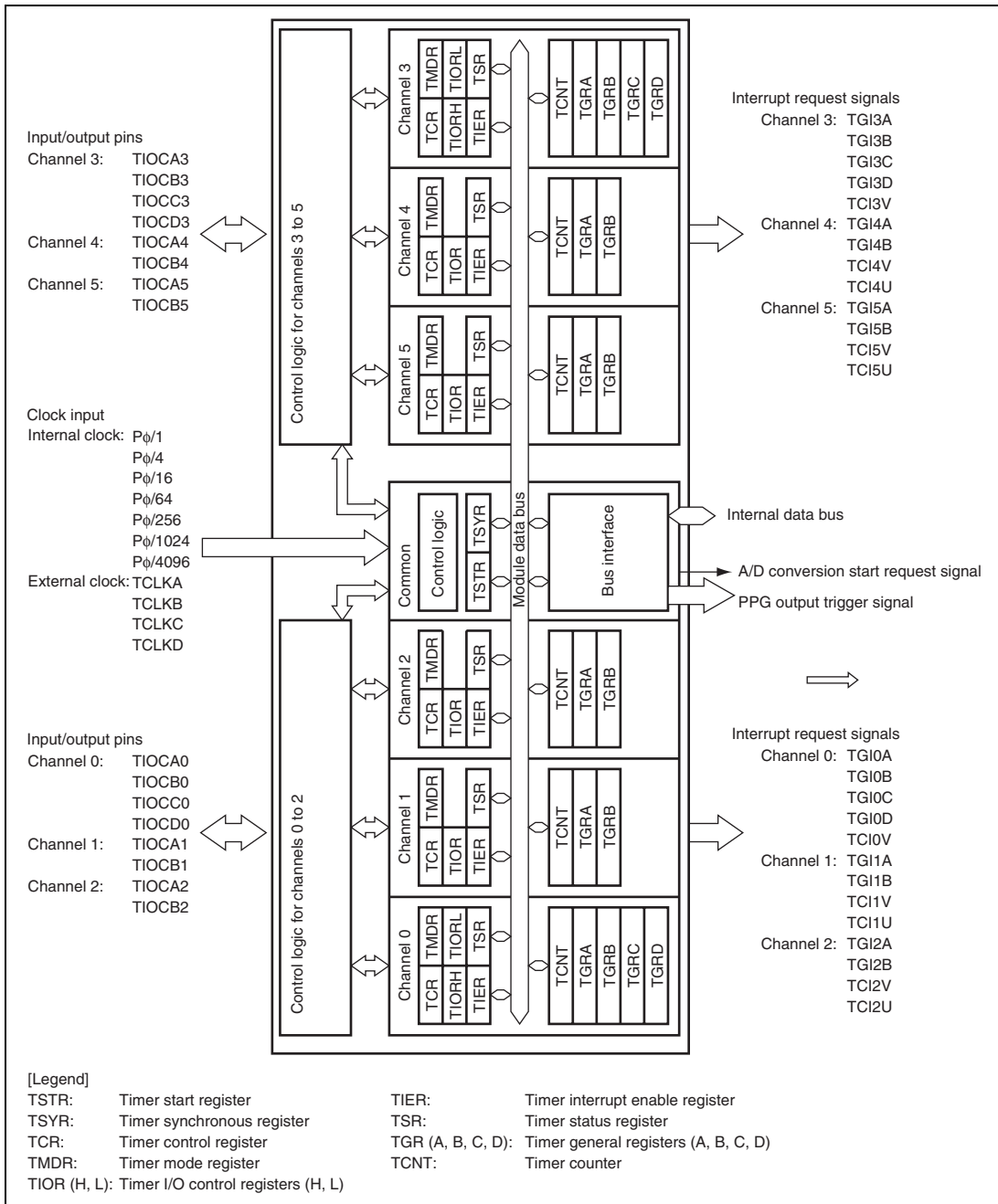

Figure 13.1 Block Diagram of TPU (Unit 0)

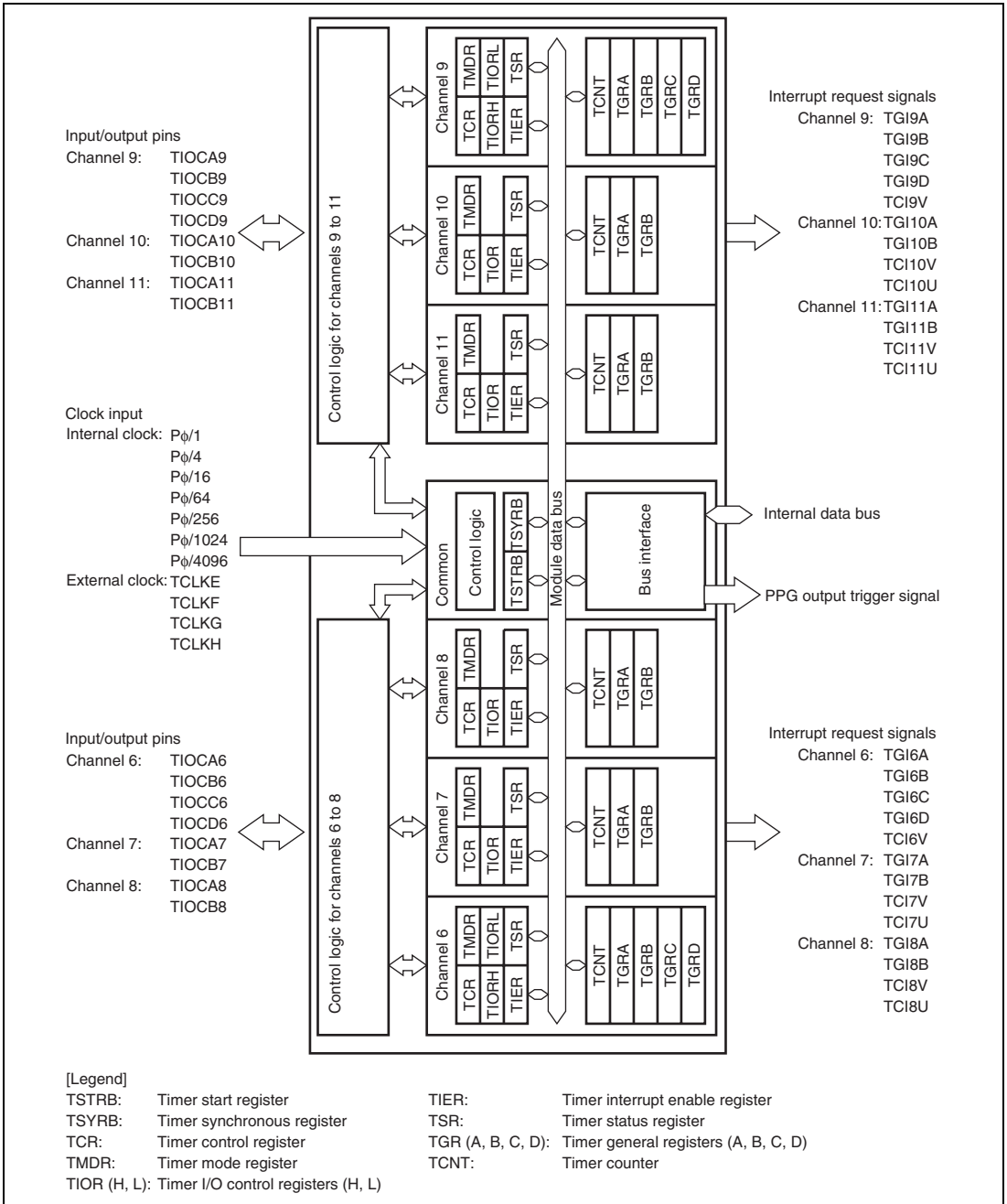

Figure 13.2 Block Diagram of TPU (Unit 1)

13.2 Input/Output Pins

Table 13.3 shows TPU pin configurations.

Table 13.3 Pin Configuration

Unit	Channel	Symbol	I/O	Function
0	All	TCLKA	Input	External clock A input pin (Channel 1 and 5 phase counting mode A phase input)
		TCLKB	Input	External clock B input pin (Channel 1 and 5 phase counting mode B phase input)
		TCLKC	Input	External clock C input pin (Channel 2 and 4 phase counting mode A phase input)
		TCLKD	Input	External clock D input pin (Channel 2 and 4 phase counting mode B phase input)
0		TIOCA0	I/O	TGRA_0 input capture input/output compare output/PWM output pin
		TIOCB0	I/O	TGRB_0 input capture input/output compare output/PWM output pin
		TIOCC0	I/O	TGRC_0 input capture input/output compare output/PWM output pin
		TIOCD0	I/O	TGRD_0 input capture input/output compare output/PWM output pin
1		TIOCA1	I/O	TGRA_1 input capture input/output compare output/PWM output pin
		TIOCB1	I/O	TGRB_1 input capture input/output compare output/PWM output pin
2		TIOCA2	I/O	TGRA_2 input capture input/output compare output/PWM output pin
		TIOCB2	I/O	TGRB_2 input capture input/output compare output/PWM output pin
3		TIOCA3	I/O	TGRA_3 input capture input/output compare output/PWM output pin
		TIOCB3	I/O	TGRB_3 input capture input/output compare output/PWM output pin
		TIOCC3	I/O	TGRC_3 input capture input/output compare output/PWM output pin
		TIOCD3	I/O	TGRD_3 input capture input/output compare output/PWM output pin
4		TIOCA4	I/O	TGRA_4 input capture input/output compare output/PWM output pin
		TIOCB4	I/O	TGRB_4 input capture input/output compare output/PWM output pin
5		TIOCA5	I/O	TGRA_5 input capture input/output compare output/PWM output pin
		TIOCB5	I/O	TGRB_5 input capture input/output compare output/PWM output pin

Unit	Channel	Symbol	I/O	Function
1	All	TCLKE	Input	External clock E input pin (Channel 7 and 11 phase counting mode A phase input)
		TCLKF	Input	External clock F input pin (Channel 7 and 11 phase counting mode B phase input)
		TCLKG	Input	External clock G input pin (Channel 8 and 10 phase counting mode A phase input)
		TCLKH	Input	External clock H input pin (Channel 8 and 10 phase counting mode B phase input)
6		TIOCA6	I/O	TGRA_6 input capture input/output compare output/PWM output pin
		TIOCB6	I/O	TGRB_6 input capture input/output compare output/PWM output pin
		TIOCC6	I/O	TGRC_6 input capture input/output compare output/PWM output pin
		TIOCD6	I/O	TGRD_6 input capture input/output compare output/PWM output pin
7		TIOCA7	I/O	TGRA_7 input capture input/output compare output/PWM output pin
		TIOCB7	I/O	TGRB_7 input capture input/output compare output/PWM output pin
8		TIOCA8	I/O	TGRA_8 input capture input/output compare output/PWM output pin
		TIOCB8	I/O	TGRB_8 input capture input/output compare output/PWM output pin
9		TIOCA9	I/O	TGRA_9 input capture input/output compare output/PWM output pin
		TIOCB9	I/O	TGRB_9 input capture input/output compare output/PWM output pin
		TIOCC9	I/O	TGRC_9 input capture input/output compare output/PWM output pin
		TIOCD9	I/O	TGRD_9 input capture input/output compare output/PWM output pin
10		TIOCA10	I/O	TGRA_10 input capture input/output compare output/PWM output pin
		TIOCB10	I/O	TGRB_10 input capture input/output compare output/PWM output pin
11		TIOCA11	I/O	TGRA_11 input capture input/output compare output/PWM output pin
		TIOCB11	I/O	TGRB_11 input capture input/output compare output/PWM output pin

13.3 Register Descriptions

The TPU has the following registers in each channel.

Registers in the unit 0 and unit 1 have the same functions except for the bit 7 in TIER, namely, the TTGE bit in unit 0 and a reserved bit in unit 1. This section gives explanations regarding unit 0.

Unit 0

- Channel 0
 - Timer control register_0 (TCR_0)
 - Timer mode register_0 (TMDR_0)
 - Timer I/O control register H_0 (TIORH_0)
 - Timer I/O control register L_0 (TIORL_0)
 - Timer interrupt enable register_0 (TIER_0)
 - Timer status register_0 (TSR_0)
 - Timer counter_0 (TCNT_0)
 - Timer general register A_0 (TGRA_0)
 - Timer general register B_0 (TGRB_0)
 - Timer general register C_0 (TGRC_0)
 - Timer general register D_0 (TGRD_0)

- Channel 1
 - Timer control register_1 (TCR_1)
 - Timer mode register_1 (TMDR_1)
 - Timer I/O control register _1 (TIOR_1)
 - Timer interrupt enable register_1 (TIER_1)
 - Timer status register_1 (TSR_1)
 - Timer counter_1 (TCNT_1)
 - Timer general register A_1 (TGRA_1)
 - Timer general register B_1 (TGRB_1)

- Channel 2
 - Timer control register_2 (TCR_2)
 - Timer mode register_2 (TMDR_2)
 - Timer I/O control register_2 (TIOR_2)
 - Timer interrupt enable register_2 (TIER_2)
 - Timer status register_2 (TSR_2)
 - Timer counter_2 (TCNT_2)
 - Timer general register A_2 (TGRA_2)
 - Timer general register B_2 (TGRB_2)

- Channel 3
 - Timer control register_3 (TCR_3)
 - Timer mode register_3 (TMDR_3)
 - Timer I/O control register H_3 (TIORH_3)
 - Timer I/O control register L_3 (TIORL_3)
 - Timer interrupt enable register_3 (TIER_3)
 - Timer status register_3 (TSR_3)
 - Timer counter_3 (TCNT_3)
 - Timer general register A_3 (TGRA_3)
 - Timer general register B_3 (TGRB_3)
 - Timer general register C_3 (TGRC_3)
 - Timer general register D_3 (TGRD_3)

- Channel 4
 - Timer control register_4 (TCR_4)
 - Timer mode register_4 (TMDR_4)
 - Timer I/O control register_4 (TIOR_4)
 - Timer interrupt enable register_4 (TIER_4)
 - Timer status register_4 (TSR_4)
 - Timer counter_4 (TCNT_4)
 - Timer general register A_4 (TGRA_4)
 - Timer general register B_4 (TGRB_4)

- Channel 5
 - Timer control register_5 (TCR_5)
 - Timer mode register_5 (TMDR_5)
 - Timer I/O control register_5 (TIOR_5)
 - Timer interrupt enable register_5 (TIER_5)
 - Timer status register_5 (TSR_5)
 - Timer counter_5 (TCNT_5)
 - Timer general register A_5 (TGRA_5)
 - Timer general register B_5 (TGRB_5)

- Common Registers
 - Timer start register (TSTR)
 - Timer synchronous register (TSYR)

Unit 1

- Channel 6
 - Timer control register_6 (TCR_6)
 - Timer mode register_6 (TMDR_6)
 - Timer I/O control register H_6 (TIORH_6)
 - Timer I/O control register L_6 (TIORL_6)
 - Timer interrupt enable register_6 (TIER_6)
 - Timer status register_6 (TSR_6)
 - Timer counter_6 (TCNT_6)
 - Timer general register A_6 (TGRA_6)
 - Timer general register B_6 (TGRB_6)
 - Timer general register C_6 (TGRC_6)
 - Timer general register D_6 (TGRD_6)

- Channel 7
 - Timer control register_7 (TCR_7)
 - Timer mode register_7 (TMDR_7)
 - Timer I/O control register_7 (TIOR_7)
 - Timer interrupt enable register_7 (TIER_7)
 - Timer status register_7 (TSR_7)
 - Timer counter_7 (TCNT_7)
 - Timer general register A_7 (TGRA_7)
 - Timer general register B_7 (TGRB_7)

- Channel 8
 - Timer control register_8 (TCR_8)
 - Timer mode register_8 (TMDR_8)
 - Timer I/O control register_8 (TIOR_8)
 - Timer interrupt enable register_8 (TIER_8)
 - Timer status register_8 (TSR_8)
 - Timer counter_8 (TCNT_8)
 - Timer general register A_8 (TGRA_8)
 - Timer general register B_8 (TGRB_8)

- Channel 9
 - Timer control register_9 (TCR_9)
 - Timer mode register_9 (TMDR_9)
 - Timer I/O control register H_9 (TIORH_9)
 - Timer I/O control register L_9 (TIORL_9)
 - Timer interrupt enable register_9 (TIER_9)
 - Timer status register_9 (TSR_9)
 - Timer counter_9 (TCNT_9)
 - Timer general register A_9 (TGRA_9)
 - Timer general register B_9 (TGRB_9)
 - Timer general register C_9 (TGRC_9)
 - Timer general register D_9 (TGRD_9)

- Channel 10
 - Timer control register_10 (TCR_10)
 - Timer mode register_10 (TMDR_10)
 - Timer I/O control register_10 (TIOR_10)
 - Timer interrupt enable register_10 (TIER_10)
 - Timer status register_10 (TSR_10)
 - Timer counter_10 (TCNT_10)
 - Timer general register A_10 (TGRA_10)
 - Timer general register B_10 (TGRB_10)

- Channel 11
 - Timer control register_11 (TCR_11)
 - Timer mode register_11 (TMDR_11)
 - Timer I/O control register_11 (TIOR_11)
 - Timer interrupt enable register_11 (TIER_11)
 - Timer status register_11 (TSR_11)
 - Timer counter_11 (TCNT_11)
 - Timer general register A_11 (TGRA_11)
 - Timer general register B_11 (TGRB_11)

- Common Registers
 - Timer start register (TSTRB)
 - Timer synchronous register (TSYRB)

13.3.1 Timer Control Register (TCR)

TCR controls the TCNT operation for each channel. The TPU has a total of six TCR registers, one for each channel. TCR register settings should be made only while TCNT operation is stopped.

Bit	7	6	5	4	3	2	1	0
Bit Name	CCLR2	CCLR1	CCLR0	CKEG1	CKEG0	TPSC2	TPSC1	TPSC0
Initial Value	0	0	0	0	0	0	0	0
R/W	R/W	R/W	R/W	R/W	R/W	R/W	R/W	R/W

Bit	Bit Name	Initial Value	R/W	Description
7	CCLR2	0	R/W	Counter Clear 2 to 0
6	CCLR1	0	R/W	These bits select the TCNT counter clearing source. See tables 13.4 and 13.5 for details.
5	CCLR0	0	R/W	
4	CKEG1	0	R/W	Clock Edge 1 and 0
3	CKEG0	0	R/W	These bits select the input clock edge. For details, see table 13.6. When the input clock is counted using both edges, the input clock period is halved (e.g. $P\phi/4$ both edges = $P\phi/2$ rising edge). If phase counting mode is used on channels 1, 2, 4, and 5, this setting is ignored and the phase counting mode setting has priority. Internal clock edge selection is valid when the input clock is $P\phi/4$ or slower. This setting is ignored if the input clock is $P\phi/1$, or when overflow/underflow of another channel is selected.
2	TPSC2	0	R/W	Timer Prescaler 2 to 0
1	TPSC1	0	R/W	These bits select the TCNT counter clock. The clock source can be selected independently for each channel. See tables 13.7 to 13.12 for details. To select the external clock as the clock source, the DDR bit and ICR bit for the corresponding pin should be set to 0 and 1, respectively. For details, see section 12, I/O Ports.
0	TPSC0	0	R/W	

Table 13.4 CCLR2 to CCLR0 (Channels 0 and 3)

Channel	Bit 7 CCLR2	Bit 6 CCLR1	Bit 5 CCLR0	Description
0, 3	0	0	0	TCNT clearing disabled
	0	0	1	TCNT cleared by TGRA compare match/input capture
	0	1	0	TCNT cleared by TGRB compare match/input capture
	0	1	1	TCNT cleared by counter clearing for another channel performing synchronous clearing/synchronous operation* ¹
	1	0	0	TCNT clearing disabled
	1	0	1	TCNT cleared by TGRC compare match/input capture* ²
	1	1	0	TCNT cleared by TGRD compare match/input capture* ²
	1	1	1	TCNT cleared by counter clearing for another channel performing synchronous clearing/synchronous operation* ¹

- Notes: 1. Synchronous operation is selected by setting the SYNC bit in TSYR to 1.
 2. When TGRC or TGRD is used as a buffer register, TCNT is not cleared because the buffer register setting has priority, and compare match/input capture does not occur.

Table 13.5 CCLR2 to CCLR0 (Channels 1, 2, 4, and 5)

Channel	Bit 7 Reserved* ²	Bit 6 CCLR1	Bit 5 CCLR0	Description
1, 2, 4, 5	0	0	0	TCNT clearing disabled
	0	0	1	TCNT cleared by TGRA compare match/input capture
	0	1	0	TCNT cleared by TGRB compare match/input capture
	0	1	1	TCNT cleared by counter clearing for another channel performing synchronous clearing/synchronous operation* ¹

- Notes: 1. Synchronous operation is selected by setting the SYNC bit in TSYR to 1.
 2. Bit 7 is reserved in channels 1, 2, 4, and 5. It is always read as 0 and cannot be modified.

Table 13.6 Input Clock Edge Selection

Clock Edge Selection		Input Clock	
CKEG1	CKEG0	Internal Clock	External Clock
0	0	Counted at falling edge	Counted at rising edge
0	1	Counted at rising edge	Counted at falling edge
1	X	Counted at both edges	Counted at both edges

[Legend]

X: Don't care

Table 13.7 TPSC2 to TPSC0 (Channel 0)

Channel	Bit 2 TPSC2	Bit 1 TPSC1	Bit 0 TPSC0	Description
0	0	0	0	Internal clock: counts on P ϕ /1
	0	0	1	Internal clock: counts on P ϕ /4
	0	1	0	Internal clock: counts on P ϕ /16
	0	1	1	Internal clock: counts on P ϕ /64
	1	0	0	External clock: counts on TCLKA pin input
	1	0	1	External clock: counts on TCLKB pin input
	1	1	0	External clock: counts on TCLKC pin input
	1	1	1	External clock: counts on TCLKD pin input

Table 13.8 TPSC2 to TPSC0 (Channel 1)

Channel	Bit 2 TPSC2	Bit 1 TPSC1	Bit 0 TPSC0	Description
1	0	0	0	Internal clock: counts on P ϕ /1
	0	0	1	Internal clock: counts on P ϕ /4
	0	1	0	Internal clock: counts on P ϕ /16
	0	1	1	Internal clock: counts on P ϕ /64
	1	0	0	External clock: counts on TCLKA pin input
	1	0	1	External clock: counts on TCLKB pin input
	1	1	0	Internal clock: counts on P ϕ /256
	1	1	1	Counts on TCNT2 overflow/underflow

Note: This setting is ignored when channel 1 is in phase counting mode.

Table 13.9 TPSC2 to TPSC0 (Channel 2)

Channel	Bit 2 TPSC2	Bit 1 TPSC1	Bit 0 TPSC0	Description
2	0	0	0	Internal clock: counts on P ϕ /1
	0	0	1	Internal clock: counts on P ϕ /4
	0	1	0	Internal clock: counts on P ϕ /16
	0	1	1	Internal clock: counts on P ϕ /64
	1	0	0	External clock: counts on TCLKA pin input
	1	0	1	External clock: counts on TCLKB pin input
	1	1	0	External clock: counts on TCLKC pin input
	1	1	1	Internal clock: counts on P ϕ /1024

Note: This setting is ignored when channel 2 is in phase counting mode.

Table 13.10 TPSC2 to TPSC0 (Channel 3)

Channel	Bit 2 TPSC2	Bit 1 TPSC1	Bit 0 TPSC0	Description
3	0	0	0	Internal clock: counts on P ϕ /1
	0	0	1	Internal clock: counts on P ϕ /4
	0	1	0	Internal clock: counts on P ϕ /16
	0	1	1	Internal clock: counts on P ϕ /64
	1	0	0	External clock: counts on TCLKA pin input
	1	0	1	Internal clock: counts on P ϕ /1024
	1	1	0	Internal clock: counts on P ϕ /256
	1	1	1	Internal clock: counts on P ϕ /4096

Table 13.11 TPSC2 to TPSC0 (Channel 4)

Channel	Bit 2 TPSC2	Bit 1 TPSC1	Bit 0 TPSC0	Description
4	0	0	0	Internal clock: counts on P ϕ /1
	0	0	1	Internal clock: counts on P ϕ /4
	0	1	0	Internal clock: counts on P ϕ /16
	0	1	1	Internal clock: counts on P ϕ /64
	1	0	0	External clock: counts on TCLKA pin input
	1	0	1	External clock: counts on TCLKC pin input
	1	1	0	Internal clock: counts on P ϕ /1024
	1	1	1	Counts on TCNT5 overflow/underflow

Note: This setting is ignored when channel 4 is in phase counting mode.

Table 13.12 TPSC2 to TPSC0 (Channel 5)

Channel	Bit 2 TPSC2	Bit 1 TPSC1	Bit 0 TPSC0	Description
5	0	0	0	Internal clock: counts on P ϕ /1
	0	0	1	Internal clock: counts on P ϕ /4
	0	1	0	Internal clock: counts on P ϕ /16
	0	1	1	Internal clock: counts on P ϕ /64
	1	0	0	External clock: counts on TCLKA pin input
	1	0	1	External clock: counts on TCLKC pin input
	1	1	0	Internal clock: counts on P ϕ /256
	1	1	1	External clock: counts on TCLKD pin input

Note: This setting is ignored when channel 5 is in phase counting mode.

13.3.2 Timer Mode Register (TMDR)

TMDR sets the operating mode for each channel. The TPU has six TMDR registers, one for each channel. TMDR register settings should be made only while TCNT operation is stopped.

Bit	7	6	5	4	3	2	1	0
Bit Name	—	—	BFB	BFA	MD3	MD2	MD1	MD0
Initial Value	1	1	0	0	0	0	0	0
R/W	—	—	R/W	R/W	R/W	R/W	R/W	R/W

Bit	Bit Name	Initial Value	R/W	Description
7, 6	—	All 1	—	Reserved These bits are always read as 1 and cannot be modified.
5	BFB	0	R/W	Buffer Operation B Specifies whether TGRB is to normally operate, or TGRB and TGRD are to be used together for buffer operation. When TGRD is used as a buffer register, TGRD input capture/output compare is not generated. In channels 1, 2, 4, and 5, which have no TGRD, bit 5 is reserved. It is always read as 0 and cannot be modified. 0: TGRB operates normally 1: TGRB and TGRD used together for buffer operation
4	BFA	0	R/W	Buffer Operation A Specifies whether TGRA is to normally operate, or TGRA and TGRC are to be used together for buffer operation. When TGRC is used as a buffer register, TGRC input capture/output compare is not generated. In channels 1, 2, 4, and 5, which have no TGRC, bit 4 is reserved. It is always read as 0 and cannot be modified. 0: TGRA operates normally 1: TGRA and TGRC used together for buffer operation
3	MD3	0	R/W	Modes 3 to 0
2	MD2	0	R/W	Set the timer operating mode.
1	MD1	0	R/W	MD3 is a reserved bit. The write value should always be 0. See table 13.13 for details.
0	MD0	0	R/W	

Table 13.13 MD3 to MD0

Bit 3 MD3* ¹	Bit 2 MD2* ²	Bit 1 MD1	Bit 0 MD0	Description
0	0	0	0	Normal operation
0	0	0	1	Reserved
0	0	1	0	PWM mode 1
0	0	1	1	PWM mode 2
0	1	0	0	Phase counting mode 1
0	1	0	1	Phase counting mode 2
0	1	1	0	Phase counting mode 3
0	1	1	1	Phase counting mode 4
1	X	X	X	—

[Legend]

X: Don't care

- Notes: 1. MD3 is a reserved bit. The write value should always be 0.
 2. Phase counting mode cannot be set for channels 0 and 3. In this case, 0 should always be written to MD2.

13.3.3 Timer I/O Control Register (TIOR)

TIOR controls TGR. The TPU has eight TIOR registers, two each for channels 0 and 3, and one each for channels 1, 2, 4, and 5. Care is required since TIOR is affected by the TMDR setting.

The initial output specified by TIOR is valid when the counter is stopped (the CST bit in TSTR is cleared to 0). Note also that, in PWM mode 2, the output at the point at which the counter is cleared to 0 is specified.

When TGRC or TGRD is designated for buffer operation, this setting is invalid and the register operates as a buffer register.

To designate the input capture pin in TIOR, the DDR bit and ICR bit for the corresponding pin should be set to 0 and 1, respectively. For details, see section 12, I/O Ports.

- TIORH_0, TIOR_1, TIOR_2, TIORH_3, TIOR_4, TIOR_5

Bit	7	6	5	4	3	2	1	0
Bit Name	IOB3	IOB2	IOB1	IOB0	IOA3	IOA2	IOA1	IOA0
Initial Value	0	0	0	0	0	0	0	0
R/W	R/W	R/W	R/W	R/W	R/W	R/W	R/W	R/W

- TIORL_0, TORL_3

Bit	7	6	5	4	3	2	1	0
Bit Name	IOD3	IOD2	IOD1	IOD0	IOC3	IOC2	IOC1	IOC0
Initial Value	0	0	0	0	0	0	0	0
R/W	R/W	R/W	R/W	R/W	R/W	R/W	R/W	R/W

- TIORH_0, TIOR_1, TIOR_2, TIORH_3, TIOR_4, TIOR_5

Bit	Bit Name	Initial Value	R/W	Description
7	IOB3	0	R/W	I/O Control B3 to B0
6	IOB2	0	R/W	Specify the function of TGRB.
5	IOB1	0	R/W	For details, see tables 13.14, 13.16 to 13.18, 13.20 and 13.21.
4	IOB0	0	R/W	
3	IOA3	0	R/W	I/O Control A3 to A0
2	IOA2	0	R/W	Specify the function of TGRA.
1	IOA1	0	R/W	For details, see tables 13.22, 13.24 to 13.26, 13.28, and 13.29.
0	IOA0	0	R/W	

- TIORL_0, TIORL_3

Bit	Bit Name	Initial Value	R/W	Description
7	IOD3	0	R/W	I/O Control D3 to D0
6	IOD2	0	R/W	Specify the function of TGRD.
5	IOD1	0	R/W	For details, see tables 13.15, and 13.19
4	IOD0	0	R/W	
3	IOC3	0	R/W	I/O Control C3 to C0
2	IOC2	0	R/W	Specify the function of TGRC.
1	IOC1	0	R/W	For details, see tables 13.23, and 13.27.
0	IOC0	0	R/W	

Table 13.14 TIORH_0

Bit 7 IOB3	Bit 6 IOB2	Bit 5 IOB1	Bit 4 IOB0	Description	
				TGRB_0 Function	TIOCB0 Pin Function
0	0	0	0	Output compare register	Output disabled
0	0	0	1		Initial output is 0 output 0 output at compare match
0	0	1	0		Initial output is 0 output 1 output at compare match
0	0	1	1		Initial output is 0 output Toggle output at compare match
0	1	0	0		Output disabled
0	1	0	1		Initial output is 1 output 0 output at compare match
0	1	1	0		Initial output is 1 output 1 output at compare match
0	1	1	1		Initial output is 1 output Toggle output at compare match
1	0	0	0	Input capture register	Capture input source is TIOCB0 pin Input capture at rising edge
1	0	0	1		Capture input source is TIOCB0 pin Input capture at falling edge
1	0	1	x		Capture input source is TIOCB0 pin Input capture at both edges
1	1	x	x		Capture input source is channel 1/count clock Input capture at TCNT_1 count-up/count-down*

[Legend]

X: Don't care

Note: * When bits TPSC2 to TPSC0 in TCR_1 are set to B'000 and P ϕ /1 is used as the TCNT_1 count clock, this setting is invalid and input capture is not generated.

Table 13.15 TIORL_0

				Description		
Bit 7 IOD3	Bit 6 IOD2	Bit 5 IOD1	Bit 4 IOD0	TGRD_0 Function	TIOCD0 Pin Function	
0	0	0	0	Output compare register*2	Output disabled	
0	0	0	1		Initial output is 0 output 0 output at compare match	
0	0	1	0		Initial output is 0 output 1 output at compare match	
0	0	1	1		Initial output is 0 output Toggle output at compare match	
0	1	0	0		Output disabled	
0	1	0	1		Initial output is 1 output 0 output at compare match	
0	1	1	0		Initial output is 1 output 1 output at compare match	
0	1	1	1		Initial output is 1 output Toggle output at compare match	
1	0	0	0		Input capture register*2	Capture input source is TIOCD0 pin Input capture at rising edge
1	0	0	1			Capture input source is TIOCD0 pin Input capture at falling edge
1	0	1	X	Capture input source is TIOCD0 pin Input capture at both edges		
1	1	X	X	Capture input source is channel 1/count clock Input capture at TCNT_1 count-up/count-down*1		

[Legend]

X: Don't care

- Notes: 1. When bits TPSC2 to TPSC0 in TCR_1 are set to B'000 and P ϕ /1 is used as the TCNT_1 count clock, this setting is invalid and input capture is not generated.
2. When the BFB bit in TMDR_0 is set to 1 and TGRD_0 is used as a buffer register, this setting is invalid and input capture/output compare is not generated.

Table 13.16 TIOR_1

				Description		
Bit 7 IOB3	Bit 6 IOB2	Bit 5 IOB1	Bit 4 IOB0	TGRB_1 Function	TIOCB1 Pin Function	
0	0	0	0	Output compare register	Output disabled	
0	0	0	1		Initial output is 0 output 0 output at compare match	
0	0	1	0		Initial output is 0 output 1 output at compare match	
0	0	1	1		Initial output is 0 output Toggle output at compare match	
0	1	0	0		Output disabled	
0	1	0	1		Initial output is 1 output 0 output at compare match	
0	1	1	0		Initial output is 1 output 1 output at compare match	
0	1	1	1		Initial output is 1 output Toggle output at compare match	
1	0	0	0		Input capture register	Capture input source is TIOCB1 pin Input capture at rising edge
1	0	0	1			Capture input source is TIOCB1 pin Input capture at falling edge
1	0	1	X	Capture input source is TIOCB1 pin Input capture at both edges		
1	1	X	X	TGRC_0 compare match/input capture Input capture at generation of TGRC_0 compare match/input capture		

[Legend]

X: Don't care

Table 13.17 TIOR_2

				Description		
Bit 7 IOB3	Bit 6 IOB2	Bit 5 IOB1	Bit 4 IOB0	TGRB_2 Function	TIOCB2 Pin Function	
0	0	0	0	Output compare register	Output disabled	
0	0	0	1		Initial output is 0 output 0 output at compare match	
0	0	1	0		Initial output is 0 output 1 output at compare match	
0	0	1	1		Initial output is 0 output Toggle output at compare match	
0	1	0	0		Output disabled	
0	1	0	1		Initial output is 1 output 0 output at compare match	
0	1	1	0		Initial output is 1 output 1 output at compare match	
0	1	1	1		Initial output is 1 output Toggle output at compare match	
1	X	0	0		Input capture register	Capture input source is TIOCB2 pin Input capture at rising edge
1	X	0	1			Capture input source is TIOCB2 pin Input capture at falling edge
1	X	1	X	Capture input source is TIOCB2 pin Input capture at both edges		

[Legend]

X: Don't care

Table 13.18 TIORH_3

Bit 7 IOB3	Bit 6 IOB2	Bit 5 IOB1	Bit 4 IOB0	TGRB_3 Function	Description	
					TIOCB3 Pin Function	
0	0	0	0	Output compare register	Output disabled	
0	0	0	1		Initial output is 0 output 0 output at compare match	
0	0	1	0		Initial output is 0 output 1 output at compare match	
0	0	1	1		Initial output is 0 output Toggle output at compare match	
0	1	0	0		Output disabled	
0	1	0	1		Initial output is 1 output 0 output at compare match	
0	1	1	0		Initial output is 1 output 1 output at compare match	
0	1	1	1		Initial output is 1 output Toggle output at compare match	
1	0	0	0		Input capture register	Capture input source is TIOCB3 pin Input capture at rising edge
1	0	0	1			Capture input source is TIOCB3 pin Input capture at falling edge
1	0	1	x	Capture input source is TIOCB3 pin Input capture at both edges		
1	1	x	x	Capture input source is channel 4/count clock Input capture at TCNT_4 count-up/count-down*		

[Legend]

X: Don't care

Note: When bits TPSC2 to TPSC0 in TCR_4 are set to B'000 and Pφ/1 is used as the TCNT_4 count clock, this setting is invalid and input capture is not generated.

Table 13.19 TIORL_3

				Description		
Bit 7 IOD3	Bit 6 IOD2	Bit 5 IOD1	Bit 4 IOD0	TGRD_3 Function	TIOCD3 Pin Function	
0	0	0	0	Output compare register*2	Output disabled	
0	0	0	1		Initial output is 0 output 0 output at compare match	
0	0	1	0		Initial output is 0 output 1 output at compare match	
0	0	1	1		Initial output is 0 output Toggle output at compare match	
0	1	0	0		Output disabled	
0	1	0	1		Initial output is 1 output 0 output at compare match	
0	1	1	0		Initial output is 1 output 1 output at compare match	
0	1	1	1		Initial output is 1 output Toggle output at compare match	
1	0	0	0		Input capture register*2	Capture input source is TIOCD3 pin Input capture at rising edge
1	0	0	1			Capture input source is TIOCD3 pin Input capture at falling edge
1	0	1	x	Capture input source is TIOCD3 pin Input capture at both edges		
1	1	x	x	Capture input source is channel 4/count clock Input capture at TCNT_4 count-up/count-down*1		

[Legend]

X: Don't care

- Notes: 1. When bits TPSC2 to TPSC0 in TCR_4 are set to B'000 and P ϕ /1 is used as the TCNT_4 count clock, this setting is invalid and input capture is not generated.
2. When the BFB bit in TMDR_3 is set to 1 and TGRD_3 is used as a buffer register, this setting is invalid and input capture/output compare is not generated.

Table 13.20 TIOR_4

Bit 7 IOB3	Bit 6 IOB2	Bit 5 IOB1	Bit 4 IOB0	Description		
				TGRB_4 Function	TIOCB4 Pin Function	
0	0	0	0	Output compare register	Output disabled	
0	0	0	1		Initial output is 0 output 0 output at compare match	
0	0	1	0		Initial output is 0 output 1 output at compare match	
0	0	1	1		Initial output is 0 output Toggle output at compare match	
0	1	0	0		Output disabled	
0	1	0	1		Initial output is 1 output 0 output at compare match	
0	1	1	0		Initial output is 1 output 1 output at compare match	
0	1	1	1		Initial output is 1 output Toggle output at compare match	
1	0	0	0		Input capture register	Capture input source is TIOCB4 pin Input capture at rising edge
1	0	0	1			Capture input source is TIOCB4 pin Input capture at falling edge
1	0	1	x	Capture input source is TIOCB4 pin Input capture at both edges		
1	1	x	x	Capture input source is TGRC_3 compare match/input capture Input capture at generation of TGRC_3 compare match/input capture		

[Legend]

X: Don't care

Table 13.21 TIOR_5

				Description		
Bit 7 IOB3	Bit 6 IOB2	Bit 5 IOB1	Bit 4 IOB0	TGRB_5 Function	TIOCB5 Pin Function	
0	0	0	0	Output compare register	Output disabled	
0	0	0	1		Initial output is 0 output 0 output at compare match	
0	0	1	0		Initial output is 0 output 1 output at compare match	
0	0	1	1		Initial output is 0 output Toggle output at compare match	
0	1	0	0		Output disabled	
0	1	0	1		Initial output is 1 output 0 output at compare match	
0	1	1	0		Initial output is 1 output 1 output at compare match	
0	1	1	1		Initial output is 1 output Toggle output at compare match	
1	x	0	0		Input capture register	Capture input source is TIOCB5 pin Input capture at rising edge
1	x	0	1			Capture input source is TIOCB5 pin Input capture at falling edge
1	x	1	x	Capture input source is TIOCB5 pin Input capture at both edges		

[Legend]

X: Don't care

Table 13.22 TIORH_0

Bit 3 IOA3	Bit 2 IOA2	Bit 1 IOA1	Bit 0 IOA0	Description	
				TGRA_0 Function	TIOCA0 Pin Function
0	0	0	0	Output compare register	Output disabled
0	0	0	1		Initial output is 0 output 0 output at compare match
0	0	1	0		Initial output is 0 output 1 output at compare match
0	0	1	1		Initial output is 0 output Toggle output at compare match
0	1	0	0		Output disabled
0	1	0	1		Initial output is 1 output 0 output at compare match
0	1	1	0		Initial output is 1 output 1 output at compare match
0	1	1	1		Initial output is 1 output Toggle output at compare match
1	0	0	1	Input capture register	Capture input source is TIOCA0 pin Input capture at rising edge
1	0	0	0		Capture input source is TIOCA0 pin Input capture at falling edge
1	0	1	X		Capture input source is TIOCA0 pin Input capture at both edges
1	1	X	X		Capture input source is channel 1/count clock Input capture at TCNT_1 count-up/count-down*

[Legend]

X: Don't care

Note: * When the bits TPSC2 to TPSC0 in TCR_1 are set to B'000 and P ϕ /1 is used as the count clock of TCNT_1, this setting is invalid and input capture is not generated.

Table 13.23 TIORL_0

				Description		
Bit 3 IOC3	Bit 2 IOC2	Bit 1 IOC1	Bit 0 IOC0	TGRC_0 Function	TIOCC0 Pin Function	
0	0	0	0	Output compare register* ²	Output disabled	
0	0	0	1		Initial output is 0 output 0 output at compare match	
0	0	1	0		Initial output is 0 output 1 output at compare match	
0	0	1	1		Initial output is 0 output Toggle output at compare match	
0	1	0	0		Output disabled	
0	1	0	1		Initial output is 1 output 0 output at compare match	
0	1	1	0		Initial output is 1 output 1 output at compare match	
0	1	1	1		Initial output is 1 output Toggle output at compare match	
1	0	0	0		Input capture register* ²	Capture input source is TIOCC0 pin Input capture at rising edge
1	0	0	1			Capture input source is TIOCC0 pin Input capture at falling edge
1	0	1	X	Capture input source is TIOCC0 pin Input capture at both edges		
1	1	X	X	Capture input source is channel 1/count clock Input capture at TCNT_1 count-up/count-down* ¹		

[Legend]

X: Don't care

- Note:
1. When the bits TPSC2 to TPSC0 in TCR_1 are set to B'000 and P ϕ /1 is used as the count clock of TCNT_1, this setting is invalid and input capture is not generated.
 2. When the BFA bit in TMDR_0 is set to 1 and TGRC_0 is used as a buffer register, this setting is invalid and input capture/output compare is not generated.

Table 13.24 TIOR_1

Bit 3 IOA3	Bit 2 IOA2	Bit 1 IOA1	Bit 0 IOA0	Description		
				TGRA_1 Function	TIOCA1 Pin Function	
0	0	0	0	Output compare register	Output disabled	
0	0	0	1		Initial output is 0 output 0 output at compare match	
0	0	1	0		Initial output is 0 output 1 output at compare match	
0	0	1	1		Initial output is 0 output Toggle output at compare match	
0	1	0	0		Output disabled	
0	1	0	1		Initial output is 1 output 0 output at compare match	
0	1	1	0		Initial output is 1 output 1 output at compare match	
0	1	1	1		Initial output is 1 output Toggle output at compare match	
1	0	0	0		Input capture register	Capture input source is TIOCA1 pin Input capture at rising edge
1	0	0	1			Capture input source is TIOCA1 pin Input capture at falling edge
1	0	1	X	Capture input source is TIOCA1 pin Input capture at both edges		
1	1	X	X	Capture input source is TGRA_0 compare match/input capture Input capture at generation of channel 0/TGRA_0 compare match/input capture		

[Legend]

X: Don't care

Table 13.25 TIOR_2

				Description		
Bit 3 IOA3	Bit 2 IOA2	Bit 1 IOA1	Bit 0 IOA0	TGRA_2 Function	TIOCA2 Pin Function	
0	0	0	0	Output compare register	Output disabled	
0	0	0	1		Initial output is 0 output 0 output at compare match	
0	0	1	0		Initial output is 0 output 1 output at compare match	
0	0	1	1		Initial output is 0 output Toggle output at compare match	
0	1	0	0		Output disabled	
0	1	0	1		Initial output is 1 output 0 output at compare match	
0	1	1	0		Initial output is 1 output 1 output at compare match	
0	1	1	1		Initial output is 1 output Toggle output at compare match	
1	X	0	0		Input capture register	Capture input source is TIOCA2 pin Input capture at rising edge
1	X	0	1			Capture input source is TIOCA2 pin Input capture at falling edge
1	X	1	X	Capture input source is TIOCA2 pin Input capture at both edges		

[Legend]

X: Don't care

Table 13.26 TIORH_3

Bit 3 IOA3	Bit 2 IOA2	Bit 1 IOA1	Bit 0 IOA0	TGRA_3 Function	Description
					TIOCA3 Pin Function
0	0	0	0	Output compare register	Output disabled
0	0	0	1		Initial output is 0 output 0 output at compare match
0	0	1	0		Initial output is 0 output 1 output at compare match
0	0	1	1		Initial output is 0 output Toggle output at compare match
0	1	0	0		Output disabled
0	1	0	1		Initial output is 1 output 0 output at compare match
0	1	1	0		Initial output is 1 output 1 output at compare match
0	1	1	1		Initial output is 1 output Toggle output at compare match
1	0	0	0	Input capture register	Capture input source is TIOCA3 pin Input capture at rising edge
1	0	0	1		Capture input source is TIOCA3 pin Input capture at falling edge
1	0	1	X		Capture input source is TIOCA3 pin Input capture at both edges
1	1	X	X		Capture input source is channel 4/count clock Input capture at TCNT_4 count-up/count-down*

[Legend]

X: Don't care

Note: * When the bits TPSC2 to TPSC0 in TCR_4 are set to B'000 and P ϕ /1 is used as the count clock of TCNT_4, this setting is invalid and input capture is not generated.

Table 13.27 TIORL_3

				Description		
Bit 3 IOC3	Bit 2 IOC2	Bit 1 IOC1	Bit 0 IOC0	TGRC_3 Function	TIOCC3 Pin Function	
0	0	0	0	Output compare register* ²	Output disabled	
0	0	0	1		Initial output is 0 output 0 output at compare match	
0	0	1	0		Initial output is 0 output 1 output at compare match	
0	0	1	1		Initial output is 0 output Toggle output at compare match	
0	1	0	0		Output disabled	
0	1	0	1		Initial output is 1 output 0 output at compare match	
0	1	1	0		Initial output is 1 output 1 output at compare match	
0	1	1	1		Initial output is 1 output Toggle output at compare match	
1	0	0	0		Input capture register* ²	Capture input source is TIOCC3 pin Input capture at rising edge
1	0	0	1			Capture input source is TIOCC3 pin Input capture at falling edge
1	0	1	X	Capture input source is TIOCC3 pin Input capture at both edges		
1	1	X	X	Capture input source is channel 4/count clock Input capture at TCNT_4 count-up/count-down* ¹		

[Legend]

X: Don't care

- Note:
1. When the bits TPSC2 to TPSC0 in TCR_4 are set to B'000 and P ϕ /1 is used as the count clock of TCNT_4, this setting is invalid and input capture is not generated.
 2. When the BFA bit in TMDR_3 is set to 1 and TGRC_3 is used as a buffer register, this setting is invalid and input capture/output compare is not generated.

Table 13.28 TIOR_4

Bit 3 IOA3	Bit 2 IOA2	Bit 1 IOA1	Bit 0 IOA0	Description	
				TGRA_4 Function	TIOCA4 Pin Function
0	0	0	0	Output compare register	Output disabled
0	0	0	1		Initial output is 0 output 0 output at compare match
0	0	1	0		Initial output is 0 output 1 output at compare match
0	0	1	1		Initial output is 0 output Toggle output at compare match
0	1	0	0		Output disabled
0	1	0	1		Initial output is 1 output 0 output at compare match
0	1	1	0		Initial output is 1 output 1 output at compare match
0	1	1	1		Initial output is 1 output Toggle output at compare match
1	0	0	0	Input capture register	Capture input source is TIOCA4 pin Input capture at rising edge
1	0	0	1		Capture input source is TIOCA4 pin Input capture at falling edge
1	0	1	X		Capture input source is TIOCA4 pin Input capture at both edges
1	1	X	X		Capture input source is TGRA_3 compare match/input capture Input capture at generation of TGRA_3 compare match/input capture

[Legend]

X: Don't care

Table 13.29 TIOR_5

Bit 3 IOA3	Bit 2 IOA2	Bit 1 IOA1	Bit 0 IOA0	Description		
				TGRA_5 Function	TIOCA5 Pin Function	
0	0	0	0	Output compare register	Output disabled	
0	0	0	1		Initial output is 0 output 0 output at compare match	
0	0	1	0		Initial output is 0 output 1 output at compare match	
0	0	1	1		Initial output is 0 output Toggle output at compare match	
0	1	0	0		Output disabled	
0	1	0	1		Initial output is 1 output 0 output at compare match	
0	1	1	0		Initial output is 1 output 1 output at compare match	
0	1	1	1		Initial output is 1 output Toggle output at compare match	
1	X	0	0		Input capture register	Input capture source is TIOCA5 pin Input capture at rising edge
1	X	0	1			Input capture source is TIOCA5 pin Input capture at falling edge
1	X	1	X	Input capture source is TIOCA5 pin Input capture at both edges		

[Legend]

X: Don't care

13.3.4 Timer Interrupt Enable Register (TIER)

TIER controls enabling or disabling of interrupt requests for each channel. The TPU has six TIER registers, one for each channel.

Bit	7	6	5	4	3	2	1	0
Bit Name	TTGE*	—	TCIEU	TCIEV	TGIED	TGIEC	TGIEB	TGIEA
Initial Value	0	1	0	0	0	0	0	0
R/W	R/W	—	R/W	R/W	R/W	R/W	R/W	R/W

Note: * Bit 7 in TIER of unit 1 is a reserved bit.
This bit is always read as 0 and the initial value should not be changed.

Bit	Bit Name	Initial value	R/W	Description
7	TTGE*	0	R/W	<p>A/D Conversion Start Request Enable</p> <p>Enables/disables generation of A/D conversion start requests by TGRA input capture/compare match.</p> <p>0: A/D conversion start request generation disabled</p> <p>1: A/D conversion start request generation enabled</p>
6	—	1	—	<p>Reserved</p> <p>This bit is always read as 1 and cannot be modified.</p>
5	TCIEU	0	R/W	<p>Underflow Interrupt Enable</p> <p>Enables/disables interrupt requests (TCIU) by the TCFU flag when the TCFU flag in TSR is set to 1 in channels 1, 2, 4, and 5.</p> <p>In channels 0 and 3, bit 5 is reserved. It is always read as 0 and cannot be modified.</p> <p>0: Interrupt requests (TCIU) by TCFU disabled</p> <p>1: Interrupt requests (TCIU) by TCFU enabled</p>
4	TCIEV	0	R/W	<p>Overflow Interrupt Enable</p> <p>Enables/disables interrupt requests (TCIV) by the TCFV flag when the TCFV flag in TSR is set to 1.</p> <p>0: Interrupt requests (TCIV) by TCFV disabled</p> <p>1: Interrupt requests (TCIV) by TCFV enabled</p>

Bit	Bit Name	Initial value	R/W	Description
3	TGIED	0	R/W	<p>TGR Interrupt Enable D</p> <p>Enables/disables interrupt requests (TGID) by the TGFD bit when the TGFD bit in TSR is set to 1 in channels 0 and 3.</p> <p>In channels 1, 2, 4, and 5, bit 3 is reserved. It is always read as 0 and cannot be modified.</p> <p>0: Interrupt requests (TGID) by TGFD bit disabled 1: Interrupt requests (TGID) by TGFD bit enabled</p>
2	TGIEC	0	R/W	<p>TGR Interrupt Enable C</p> <p>Enables/disables interrupt requests (TGIC) by the TGFC bit when the TGFC bit in TSR is set to 1 in channels 0 and 3.</p> <p>In channels 1, 2, 4, and 5, bit 2 is reserved. It is always read as 0 and cannot be modified.</p> <p>0: Interrupt requests (TGIC) by TGFC bit disabled 1: Interrupt requests (TGIC) by TGFC bit enabled</p>
1	TGIEB	0	R/W	<p>TGR Interrupt Enable B</p> <p>Enables/disables interrupt requests (TGIB) by the TGFB bit when the TGFB bit in TSR is set to 1.</p> <p>0: Interrupt requests (TGIB) by TGFB bit disabled 1: Interrupt requests (TGIB) by TGFB bit enabled</p>
0	TGIEA	0	R/W	<p>TGR Interrupt Enable A</p> <p>Enables/disables interrupt requests (TGIA) by the TGFA bit when the TGFA bit in TSR is set to 1.</p> <p>0: Interrupt requests (TGIA) by TGFA bit disabled 1: Interrupt requests (TGIA) by TGFA bit enabled</p>

Note: * The bit 7 in TIER of unit 1 is a reserved bit This bit is always read as 0 and the initial value should not be changed.

13.3.5 Timer Status Register (TSR)

TSR indicates the status of each channel. The TPU has six TSR registers, one for each channel.

Bit	7	6	5	4	3	2	1	0
Bit Name	TCFD	—	TCFU	TCFV	TGFD	TGFC	TGFB	TGFA
Initial Value	1	1	0	0	0	0	0	0
R/W	R	—	R/(W)*	R/(W)*	R/(W)*	R/(W)*	R/(W)*	R/(W)*

Note: * Only 0 can be written to bits 5 to 0, to clear flags.

Bit	Bit Name	Initial value	R/W	Description
7	TCFD	1	R	<p>Count Direction Flag</p> <p>Status flag that shows the direction in which TCNT counts in channels 1, 2, 4, and 5.</p> <p>In channels 0 and 3, bit 7 is reserved. It is always read as 1 and cannot be modified.</p> <p>0: TCNT counts down 1: TCNT counts up</p>
6	—	1	—	<p>Reserved</p> <p>This bit is always read as 1 and cannot be modified.</p>
5	TCFU	0	R/(W)*	<p>Underflow Flag</p> <p>Status flag that indicates that a TCNT underflow has occurred when channels 1, 2, 4, and 5 are set to phase counting mode.</p> <p>In channels 0 and 3, bit 5 is reserved. It is always read as 0 and cannot be modified.</p> <p>[Setting condition]</p> <p>When the TCNT value underflows (changes from H'0000 to H'FFFF)</p> <p>[Clearing condition]</p> <p>When a 0 is written to TCFU after reading TCFU = 1</p> <p>(When the CPU is used to clear this flag by writing 0 while the corresponding interrupt is enabled, be sure to read the flag after writing 0 to it.)</p>
4	TCFV	0	R/(W)*	<p>Overflow Flag</p> <p>Status flag that indicates that a TCNT overflow has occurred.</p> <p>[Setting condition]</p> <p>When the TCNT value overflows (changes from H'FFFF to H'0000)</p> <p>[Clearing condition]</p> <p>When a 0 is written to TCFV after reading TCFV = 1</p> <p>(When the CPU is used to clear this flag by writing 0 while the corresponding interrupt is enabled, be sure to read the flag after writing 0 to it.)</p>

Bit	Bit Name	Initial value	R/W	Description
3	TGFD	0	R/(W)*	<p>Input Capture/Output Compare Flag D</p> <p>Status flag that indicates the occurrence of TGRD input capture or compare match in channels 0 and 3.</p> <p>In channels 1, 2, 4, and 5, bit 3 is reserved. It is always read as 0 and cannot be modified.</p> <p>[Setting conditions]</p> <ul style="list-style-type: none"> When TCNT = TGRD while TGRD is functioning as output compare register When TCNT value is transferred to TGRD by input capture signal while TGRD is functioning as input capture register <p>[Clearing conditions]</p> <ul style="list-style-type: none"> When DTC is activated by a TGID interrupt while the DISEL bit in MRB of DTC is 0 When 0 is written to TGFD after reading TGFD = 1 (When the CPU is used to clear this flag by writing 0 while the corresponding interrupt is enabled, be sure to read the flag after writing 0 to it.)
2	TGFC	0	R/(W)*	<p>Input Capture/Output Compare Flag C</p> <p>Status flag that indicates the occurrence of TGRC input capture or compare match in channels 0 and 3.</p> <p>In channels 1, 2, 4, and 5, bit 2 is reserved. It is always read as 0 and cannot be modified.</p> <p>[Setting conditions]</p> <ul style="list-style-type: none"> When TCNT = TGRC while TGRC is functioning as output compare register When TCNT value is transferred to TGRC by input capture signal while TGRC is functioning as input capture register <p>[Clearing conditions]</p> <ul style="list-style-type: none"> When DTC is activated by a TGIC interrupt while the DISEL bit in MRB of DTC is 0 When 0 is written to TGFC after reading TGFC = 1 (When the CPU is used to clear this flag by writing 0 while the corresponding interrupt is enabled, be sure to read the flag after writing 0 to it.)

Bit	Bit Name	Initial value	R/W	Description
1	TGFB	0	R/(W)*	<p>Input Capture/Output Compare Flag B</p> <p>Status flag that indicates the occurrence of TGRB input capture or compare match.</p> <p>[Setting conditions]</p> <ul style="list-style-type: none"> • When TCNT = TGRB while TGRB is functioning as output compare register • When TCNT value is transferred to TGRB by input capture signal while TGRB is functioning as input capture register <p>[Clearing conditions]</p> <ul style="list-style-type: none"> • When DTC is activated by a TGIB interrupt while the DISEL bit in MRB of DTC is 0 • When 0 is written to TGFB after reading TGFB = 1 (When the CPU is used to clear this flag by writing 0 while the corresponding interrupt is enabled, be sure to read the flag after writing 0 to it.)
0	TGFA	0	R/(W)*	<p>Input Capture/Output Compare Flag A</p> <p>Status flag that indicates the occurrence of TGRA input capture or compare match.</p> <p>[Setting conditions]</p> <ul style="list-style-type: none"> • When TCNT = TGRA while TGRA is functioning as output compare register • When TCNT value is transferred to TGRA by input capture signal while TGRA is functioning as input capture register <p>[Clearing conditions]</p> <ul style="list-style-type: none"> • When DTC is activated by a TGIA interrupt while the DISEL bit in MRB of DTC is 0 • When DMAC is activated by a TGIA interrupt while the DTA bit in DMDR of DTC is 1 • When 0 is written to TGFA after reading TGFA = 1 (When the CPU is used to clear this flag by writing 0 while the corresponding interrupt is enabled, be sure to read the flag after writing 0 to it.)

Note: * Only 0 can be written to clear the flag.

13.3.6 Timer Counter (TCNT)

TCNT is a 16-bit readable/writable counter. The TPU has six TCNT counters, one for each channel.

TCNT is initialized to H'0000 by a reset or in hardware standby mode.

TCNT cannot be accessed in 8-bit units. TCNT must always be accessed in 16-bit units.

Bit	15	14	13	12	11	10	9	8
Bit Name								
Initial Value	0	0	0	0	0	0	0	0
R/W	R/W	R/W	R/W	R/W	R/W	R/W	R/W	R/W
Bit	7	6	5	4	3	2	1	0
Bit Name								
Initial Value	0	0	0	0	0	0	0	0
R/W	R/W	R/W	R/W	R/W	R/W	R/W	R/W	R/W

13.3.7 Timer General Register (TGR)

TGR is a 16-bit readable/writable register with a dual function as output compare and input capture registers. The TPU has 16 TGR registers, four each for channels 0 and 3 and two each for channels 1, 2, 4, and 5. TGRC and TGRD for channels 0 and 3 can also be designated for operation as buffer registers. The TGR registers cannot be accessed in 8-bit units; they must always be accessed in 16-bit units. TGR and buffer register combinations during buffer operations are TGRA–TGRC and TGRB–TGRD.

Bit	15	14	13	12	11	10	9	8
Bit Name								
Initial Value	1	1	1	1	1	1	1	1
R/W	R/W	R/W	R/W	R/W	R/W	R/W	R/W	R/W
Bit	7	6	5	4	3	2	1	0
Bit Name								
Initial Value	1	1	1	1	1	1	1	1
R/W	R/W	R/W	R/W	R/W	R/W	R/W	R/W	R/W

13.3.8 Timer Start Register (TSTR)

TSTR starts or stops operation for channels 0 to 5. When setting the operating mode in TMDR or setting the count clock in TCR, first stop the TCNT counter.

Bit	7	6	5	4	3	2	1	0
Bit Name	—	—	CST5	CST4	CST3	CST2	CST1	CST0
Initial Value	0	0	0	0	0	0	0	0
R/W	—	—	R/W	R/W	R/W	R/W	R/W	R/W

Bit	Bit Name	Initial value	R/W	Description
7, 6	—	All 0	—	Reserved The write value should always be 0.
5	CST5	0	R/W	Counter Start 5 to 0
4	CST4	0	R/W	These bits select operation or stoppage for TCNT.
3	CST3	0	R/W	If 0 is written to the CST bit during operation with the TIOC pin designated for output, the counter stops but the TIOC pin output compare output level is retained. If TIOR is written to when the CST bit is cleared to 0, the pin output level will be changed to the set initial output value.
2	CST2	0	R/W	
1	CST1	0	R/W	
0	CST0	0	R/W	
				0: TCNT_5 to TCNT_0 count operation is stopped 1: TCNT_5 to TCNT_0 performs count operation

13.3.9 Timer Synchronous Register (TSYR)

TSYR selects independent operation or synchronous operation for the TCNT counters of channels 0 to 5. A channel performs synchronous operation when the corresponding bit in TSYR is set to 1.

Bit	7	6	5	4	3	2	1	0
Bit Name	—	—	SYNC5	SYNC4	SYNC3	SYNC2	SYNC1	SYNC0
Initial Value	0	0	0	0	0	0	0	0
R/W	R/W	R/W	R/W	R/W	R/W	R/W	R/W	R/W

Bit	Bit Name	Initial value	R/W	Description
7, 6	—	All 0	R/W	Reserved The write value should always be 0.
5	SYNC5	0	R/W	Timer Synchronization 5 to 0
4	SYNC4	0	R/W	These bits select whether operation is independent of or synchronized with other channels.
3	SYNC3	0	R/W	When synchronous operation is selected, synchronous presetting of multiple channels, and synchronous clearing through counter clearing on another channel are possible.
2	SYNC2	0	R/W	
1	SYNC1	0	R/W	
0	SYNC0	0	R/W	To set synchronous operation, the SYNC bits for at least two channels must be set to 1. To set synchronous clearing, in addition to the SYNC bit, the TCNT clearing source must also be set by means of bits CCLR2 to CCLR0 in TCR. 0: TCNT_5 to TCNT_0 operate independently (TCNT presetting/clearing is unrelated to other channels) 1: TCNT_5 to TCNT_0 perform synchronous operation (TCNT synchronous presetting/synchronous clearing is possible)

13.4 Operation

13.4.1 Basic Functions

Each channel has a TCNT and TGR register. TCNT performs up-counting, and is also capable of free-running operation, periodic counting, and external event counting.

Each TGR can be used as an input capture register or output compare register.

(1) Counter Operation

When one of bits CST0 to CST5 is set to 1 in TSTR, the TCNT counter for the corresponding channel starts counting. TCNT can operate as a free-running counter, periodic counter, and so on.

(a) Example of count operation setting procedure

Figure 13.3 shows an example of the count operation setting procedure.

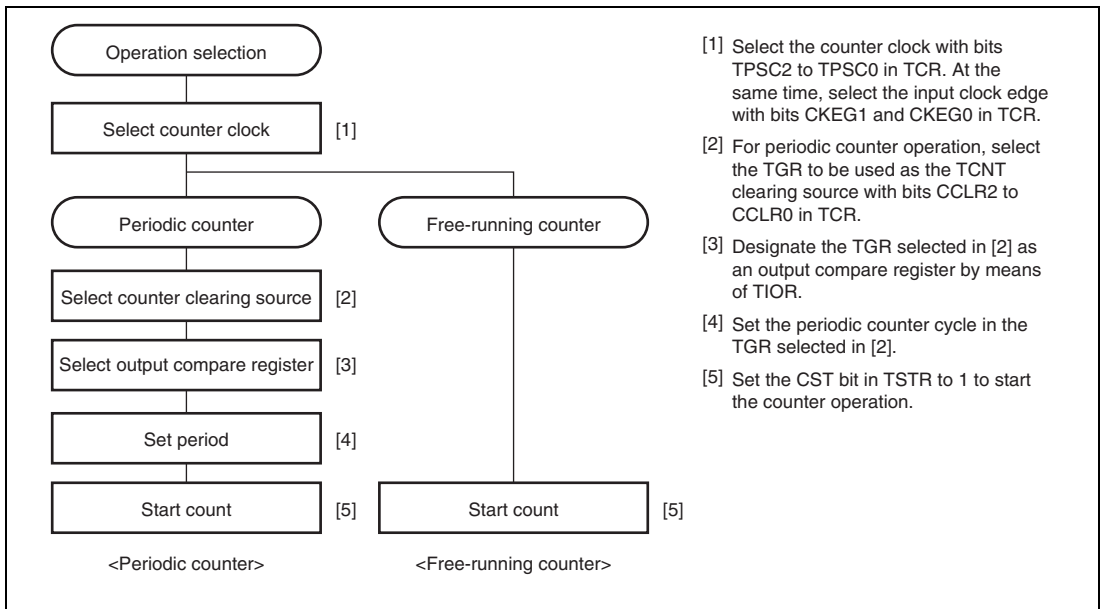

Figure 13.3 Example of Counter Operation Setting Procedure

(b) Free-running count operation and periodic count operation

Immediately after a reset, the TPU's TCNT counters are all designated as free-running counters. When the relevant bit in TSTR is set to 1 the corresponding TCNT counter starts up-count operation as a free-running counter. When TCNT overflows (changes from H'FFFF to H'0000), the TCFV bit in TSR is set to 1. If the value of the corresponding TCIEV bit in TIER is 1 at this point, the TPU requests an interrupt. After overflow, TCNT starts counting up again from H'0000.

Figure 13.4 illustrates free-running counter operation.

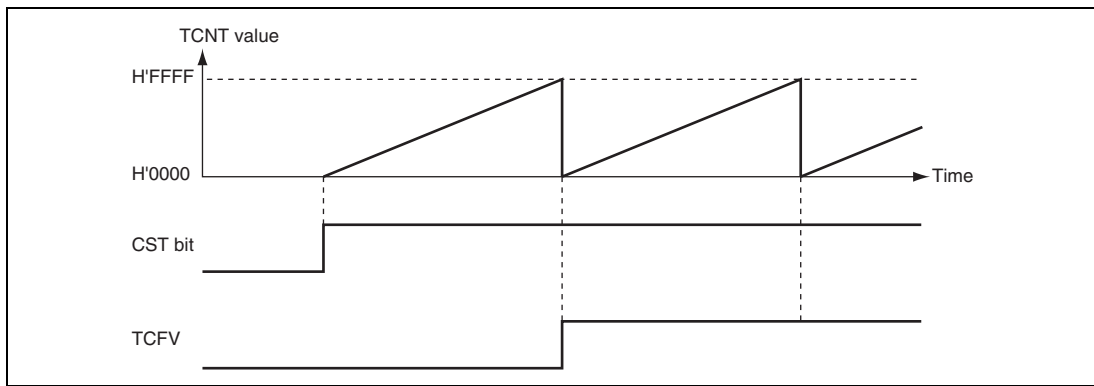

Figure 13.4 Free-Running Counter Operation

When compare match is selected as the TCNT clearing source, the TCNT counter for the relevant channel performs periodic count operation. The TGR register for setting the period is designated as an output compare register, and counter clearing by compare match is selected by means of bits CCLR2 to CCLR0 in TCR. After the settings have been made, TCNT starts count-up operation as a periodic counter when the corresponding bit in TSTR is set to 1. When the count value matches the value in TGR, the TGF bit in TSR is set to 1 and TCNT is cleared to H'0000.

If the value of the corresponding TGIE bit in TIER is 1 at this point, the TPU requests an interrupt. After a compare match, TCNT starts counting up again from H'0000.

Figure 13.5 illustrates periodic counter operation.

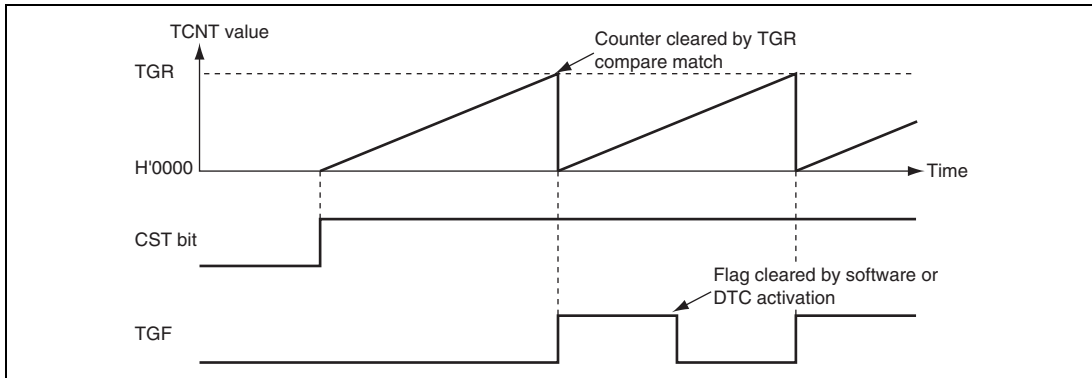

Figure 13.5 Periodic Counter Operation

(2) Waveform Output by Compare Match

The TPU can perform 0, 1, or toggle output from the corresponding output pin using a compare match.

(a) Example of setting procedure for waveform output by compare match

Figure 13.6 shows an example of the setting procedure for waveform output by a compare match.

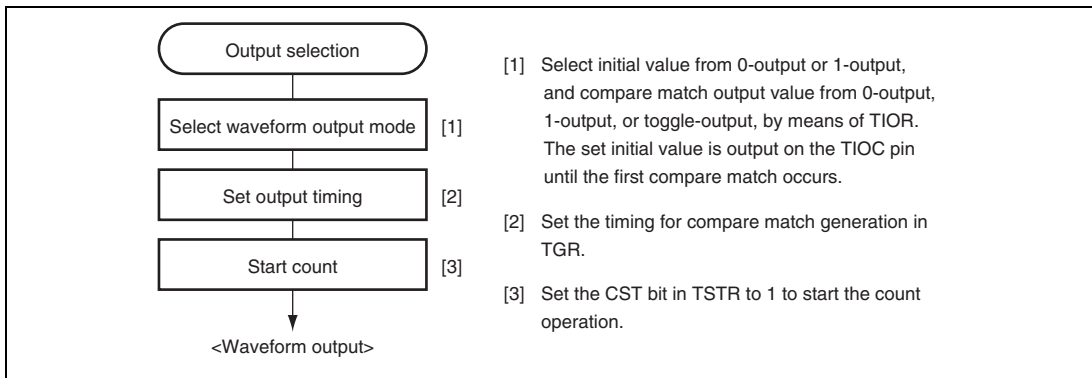

Figure 13.6 Example of Setting Procedure for Waveform Output by Compare Match

(b) Examples of waveform output operation

Figure 13.7 shows an example of 0 output/1 output .

In this example, TCNT has been designated as a free-running counter, and settings have been made so that 1 is output by compare match A, and 0 is output by compare match B. When the set level and the pin level match, the pin level does not change.

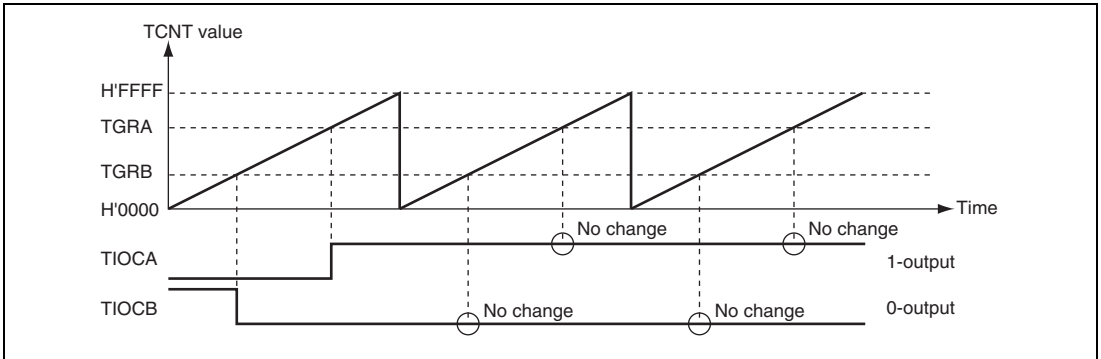

Figure 13.7 Example of 0-Output/1-Output Operation

Figure 13.8 shows an example of toggle output.

In this example, TCNT has been designated as a periodic counter (with counter clearing performed by compare match B), and settings have been made so that output is toggled by both compare match A and compare match B.

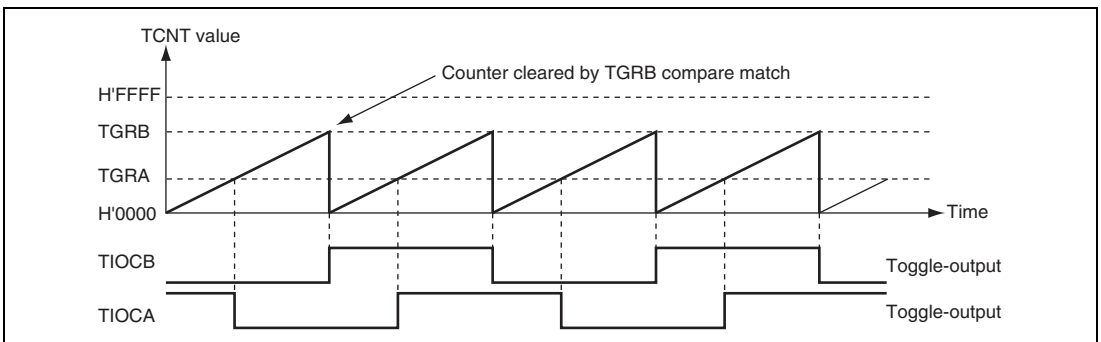

Figure 13.8 Example of Toggle Output Operation

(3) Input Capture Function

The TCNT value can be transferred to TGR on detection of the TIOC pin input edge.

Rising edge, falling edge, or both edges can be selected as the detection edge. For channels 0, 1, 3, and 4, it is also possible to specify another channel's counter input clock or compare match signal as the input capture source.

Note: When another channel's counter input clock is used as the input capture input for channels 0 and 3, P ϕ /1 should not be selected as the counter input clock used for input capture input. Input capture will not be generated if P ϕ /1 is selected.

(a) Example of setting procedure for input capture operation

Figure 13.9 shows an example of the setting procedure for input capture operation.

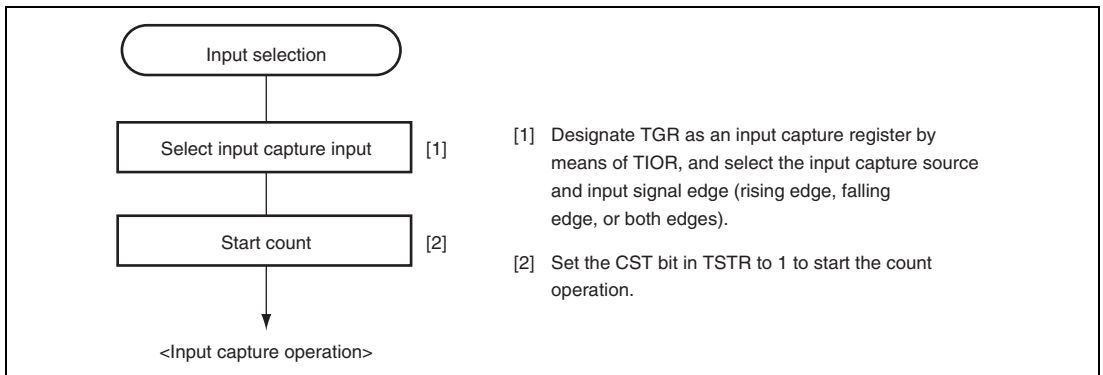

Figure 13.9 Example of Setting Procedure for Input Capture Operation

(b) Example of input capture operation

Figure 13.10 shows an example of input capture operation.

In this example, both rising and falling edges have been selected as the TIOCA pin input capture input edge, falling edge has been selected as the TIOCB pin input capture input edge, and counter clearing by TGRB input capture has been designated for TCNT.

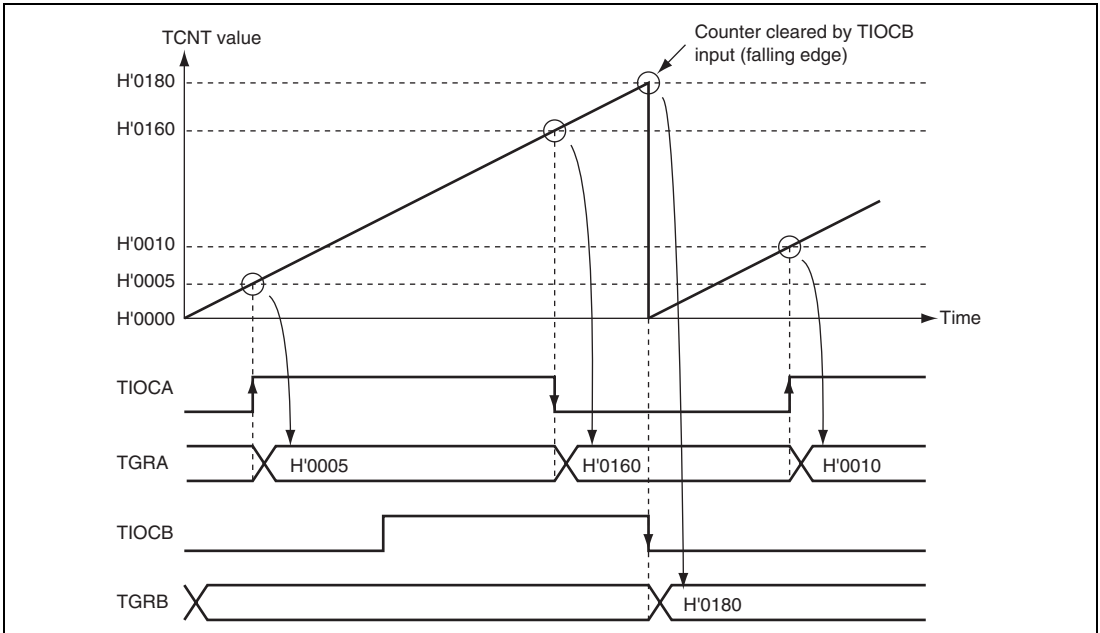

Figure 13.10 Example of Input Capture Operation

13.4.2 Synchronous Operation

In synchronous operation, the values in multiple TCNT counters can be rewritten simultaneously (synchronous presetting). Also, multiple TCNT counters can be cleared simultaneously (synchronous clearing) by making the appropriate setting in TCR.

Synchronous operation enables TGR to be incremented with respect to a single time base.

Channels 0 to 5 can all be designated for synchronous operation.

(1) Example of Synchronous Operation Setting Procedure

Figure 13.11 shows an example of the synchronous operation setting procedure.

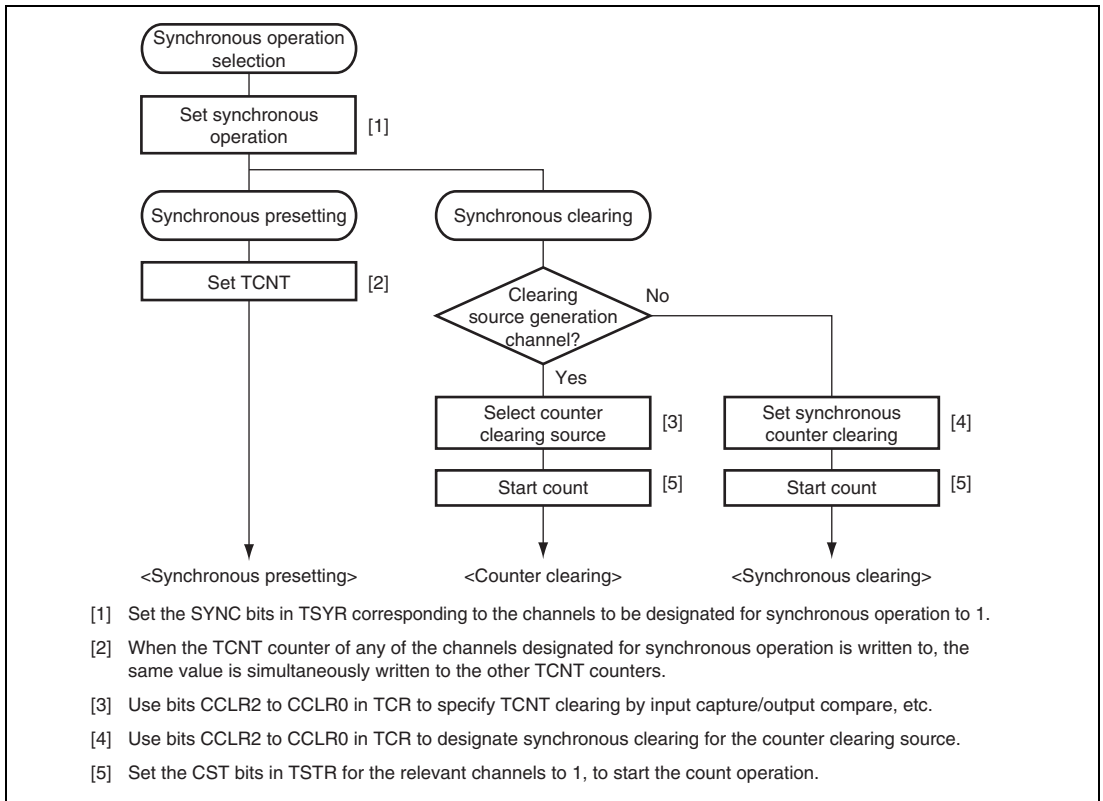

Figure 13.11 Example of Synchronous Operation Setting Procedure

(2) Example of Synchronous Operation

Figure 13.12 shows an example of synchronous operation.

In this example, synchronous operation and PWM mode 1 have been designated for channels 0 to 2, TGRB_0 compare match has been set as the channel 0 counter clearing source, and synchronous clearing has been set for the channel 1 and 2 counter clearing source.

Three-phase PWM waveforms are output from pins TIOCA0, TIOCA1, and TIOCA2. At this time, synchronous presetting and synchronous clearing by TGRB_0 compare match are performed for channel 0 to 2 TCNT counters, and the data set in TGRB_0 is used as the PWM cycle.

For details on PWM modes, see section 13.4.5, PWM Modes.

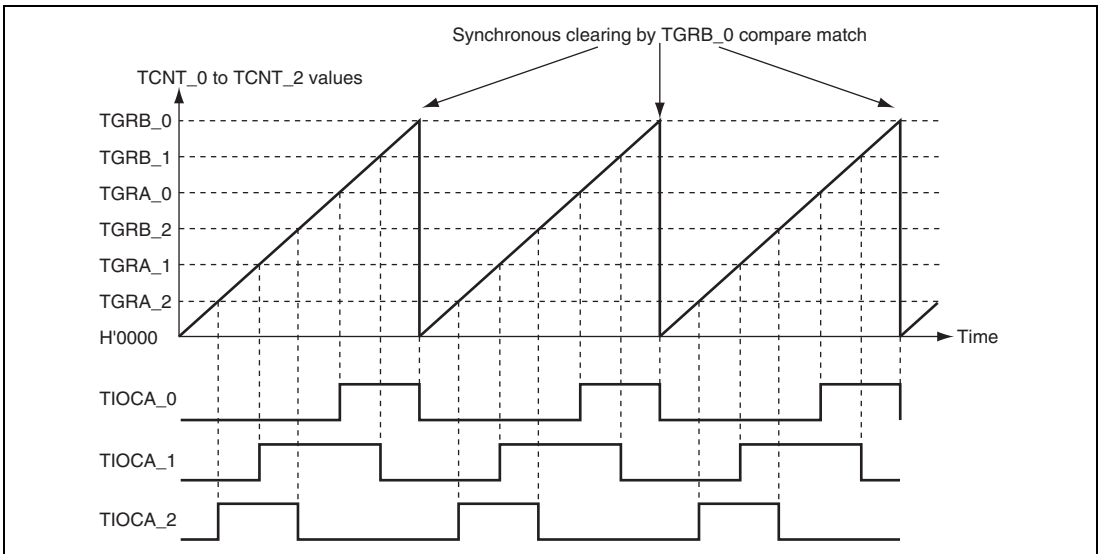

Figure 13.12 Example of Synchronous Operation

13.4.3 Buffer Operation

Buffer operation, provided for channels 0 and 3, enables TGRC and TGRD to be used as buffer registers.

Buffer operation differs depending on whether TGR has been designated as an input capture register or a compare match register.

Table 13.30 shows the register combinations used in buffer operation.

Table 13.30 Register Combinations in Buffer Operation

Channel	Timer General Register	Buffer Register
0	TGRA_0	TGRC_0
	TGRB_0	TGRD_0
3	TGRA_3	TGRC_3
	TGRB_3	TGRD_3

- When TGR is an output compare register
 - When a compare match occurs, the value in the buffer register for the corresponding channel is transferred to the timer general register.
 - This operation is illustrated in Figure 13.13.

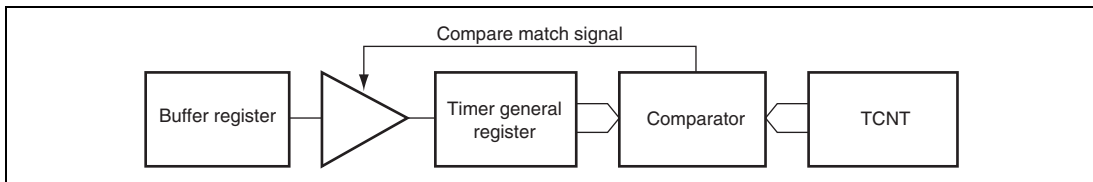

Figure 13.13 Compare Match Buffer Operation

- When TGR is an input capture register

When input capture occurs, the value in TCNT is transferred to TGR and the value previously held in TGR is transferred to the buffer register.

This operation is illustrated in Figure 13.14.

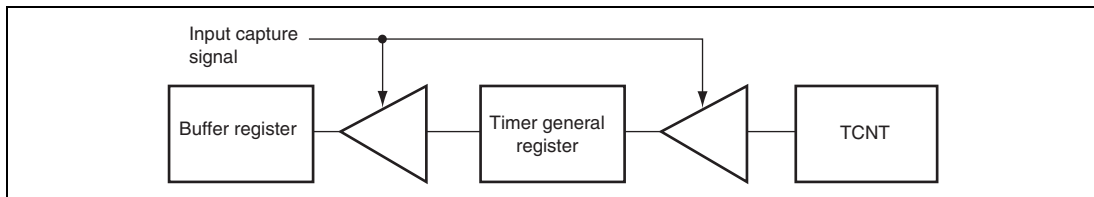

Figure 13.14 Input Capture Buffer Operation

(1) Example of Buffer Operation Setting Procedure

Figure 13.15 shows an example of the buffer operation setting procedure.

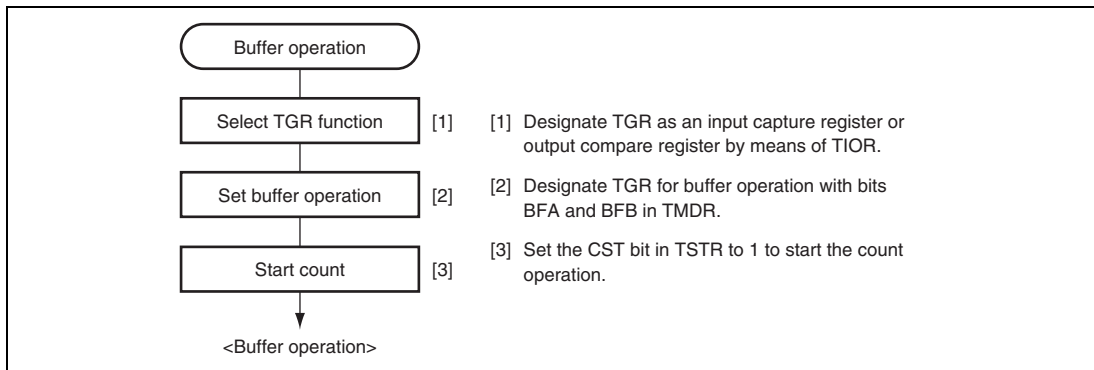

Figure 13.15 Example of Buffer Operation Setting Procedure

(2) Examples of Buffer Operation

(a) When TGR is an output compare register

Figure 13.16 shows an operation example in which PWM mode 1 has been designated for channel 0, and buffer operation has been designated for TGRA and TGRC. The settings used in this example are TCNT clearing by compare match B, 1 output at compare match A, and 0 output at compare match B.

As buffer operation has been set, when compare match A occurs, the output changes and the value in buffer register TGRC is simultaneously transferred to timer general register TGRA. This operation is repeated each time compare match A occurs.

For details on PWM modes, see section 13.4.5, PWM Modes.

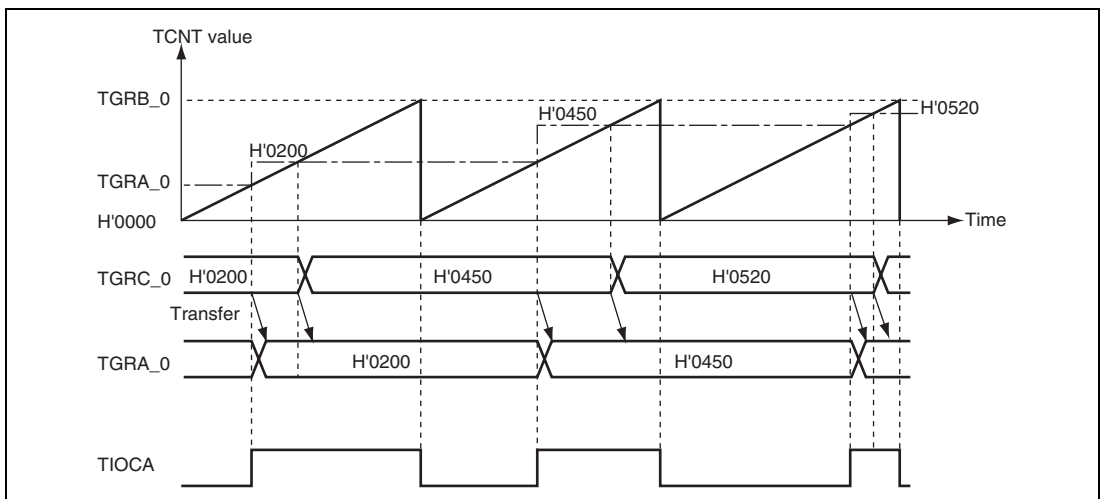

Figure 13.16 Example of Buffer Operation (1)

(b) When TGR is an input capture register

Figure 13.17 shows an operation example in which TGRA has been designated as an input capture register, and buffer operation has been designated for TGRA and TGRC.

Counter clearing by TGRA input capture has been set for TCNT, and both rising and falling edges have been selected as the TIOCA pin input capture input edge.

As buffer operation has been set, when the TCNT value is stored in TGRA upon occurrence of input capture A, the value previously stored in TGRA is simultaneously transferred to TGRC.

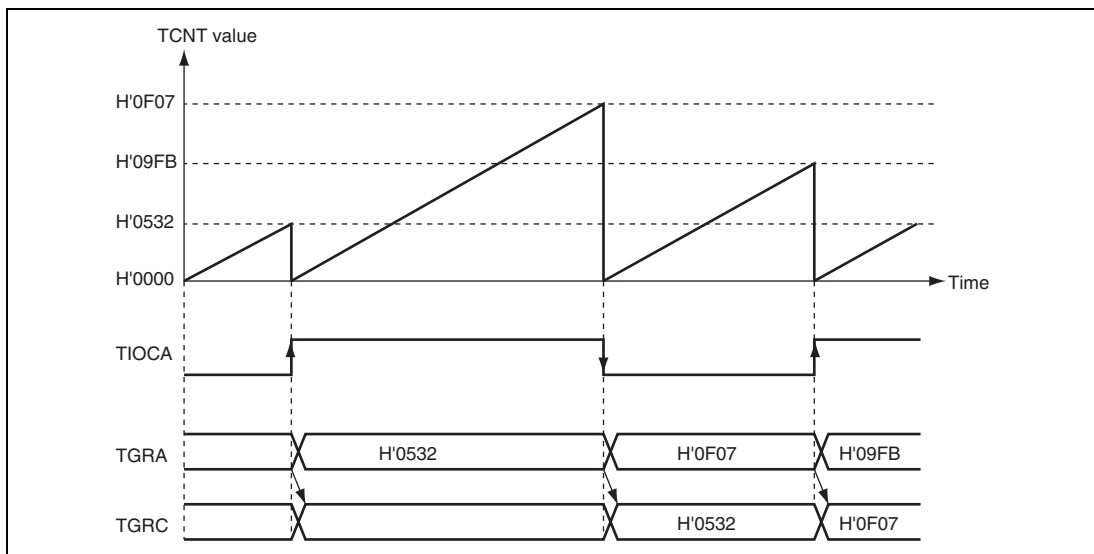

Figure 13.17 Example of Buffer Operation (2)

13.4.4 Cascaded Operation

In cascaded operation, two 16-bit counters for different channels are used together as a 32-bit counter.

This function works by counting the channel 1 (channel 4) counter clock at overflow/underflow of TCNT_2 (TCNT_5) as set in bits TPSC2 to TPSC0 in TCR.

Underflow occurs only when the lower 16-bit TCNT is in phase-counting mode.

Table 13.31 shows the register combinations used in cascaded operation.

Note: When phase counting mode is set for channel 1 or 4, the counter clock setting is invalid and the counter operates independently in phase counting mode.

Table 13.31 Cascaded Combinations

Combination	Upper 16 Bits	Lower 16 Bits
Channels 1 and 2	TCNT_1	TCNT_2
Channels 4 and 5	TCNT_4	TCNT_5

(1) Example of Cascaded Operation Setting Procedure

Figure 13.18 shows an example of the setting procedure for cascaded operation.

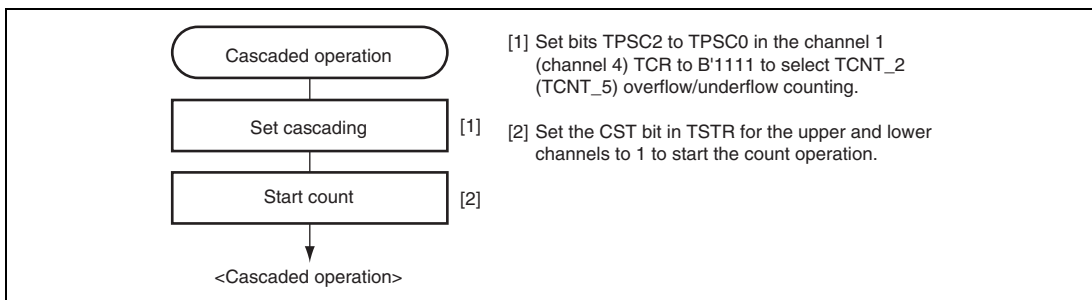

Figure 13.18 Cascaded Operation Setting Procedure

(2) Examples of Cascaded Operation

Figure 13.19 illustrates the operation when counting upon TCNT_2 overflow/underflow has been set for TCNT_1, TGRA_1 and TGRA_2 have been designated as input capture registers, and the TIOC pin rising edge has been selected.

When a rising edge is input to the TIOCA1 and TIOCA2 pins simultaneously, the upper 16 bits of the 32-bit data are transferred to TGRA_1, and the lower 16 bits to TGRA_2.

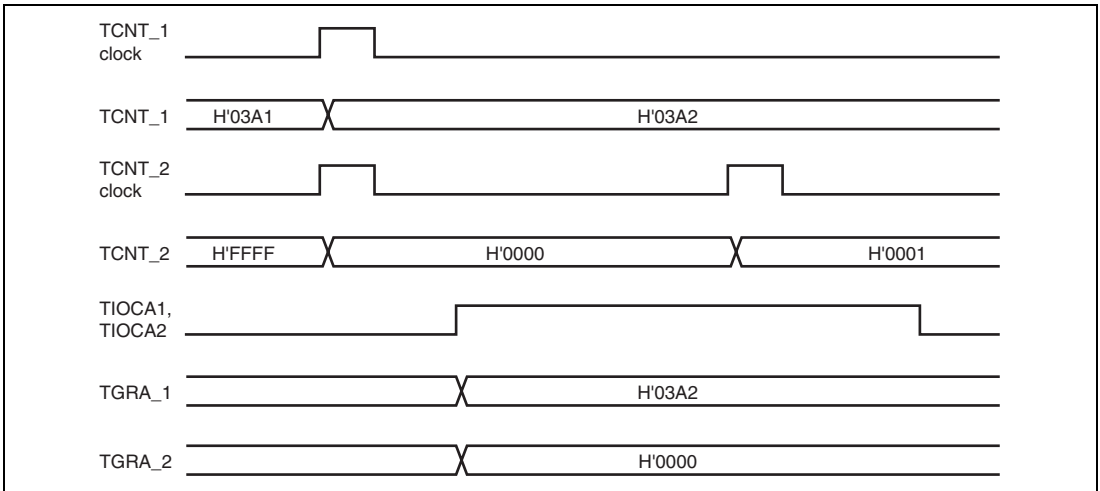

Figure 13.19 Example of Cascaded Operation (1)

Figure 13.20 illustrates the operation when counting upon TCNT_2 overflow/underflow has been set for TCNT_1, and phase counting mode has been designated for channel 2.

TCNT_1 is incremented by TCNT_2 overflow and decremented by TCNT_2 underflow.

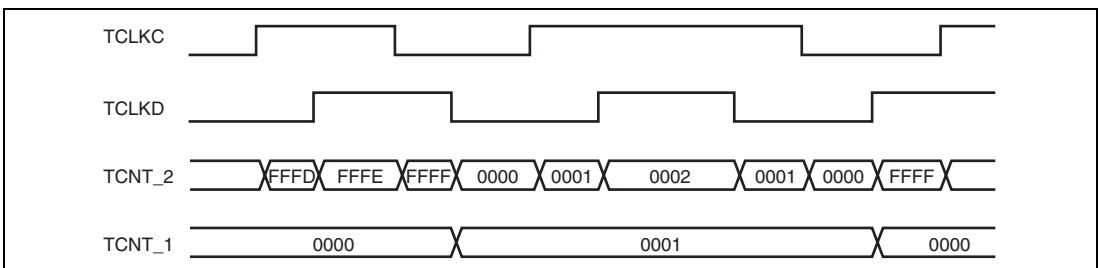

Figure 13.20 Example of Cascaded Operation (2)

13.4.5 PWM Modes

In PWM mode, PWM waveforms are output from the output pins. 0-, 1-, or toggle-output can be selected as the output level in response to compare match of each TGR.

Settings of TGR registers can output a PWM waveform in the range of 0% to 100% duty cycle.

Designating TGR compare match as the counter clearing source enables the cycle to be set in that register. All channels can be designated for PWM mode independently. Synchronous operation is also possible.

There are two PWM modes, as described below.

1. PWM mode 1

PWM output is generated from the TIOCA and TIOCC pins by pairing TGRA with TGRB and TGRC with TGRD. The outputs specified by bits IOA3 to IOA0 and IOC3 to IOC0 in TIOR are output from the TIOCA and TIOCC pins at compare matches A and C, respectively. The outputs specified by bits IOB3 to IOB0 and IOD3 to IOD0 in TIOR are output at compare matches B and D, respectively. The initial output value is the value set in TGRA or TGRC. If the set values of paired TGRs are identical, the output value does not change when a compare match occurs.

In PWM mode 1, a maximum 8-phase PWM output is possible.

2. PWM mode 2

PWM output is generated using one TGR as the cycle register and the others as duty cycle registers. The output specified in TIOR is performed by means of compare matches. Upon counter clearing by a synchronous register compare match, the output value of each pin is the initial value set in TIOR. If the set values of the cycle and duty cycle registers are identical, the output value does not change when a compare match occurs.

In PWM mode 2, a maximum 15-phase PWM output is possible by combined use with synchronous operation.

The correspondence between PWM output pins and registers is shown in table 13.32.

Table 13.32 PWM Output Registers and Output Pins

Channel	Registers	Output Pins	
		PWM Mode 1	PWM Mode 2
0	TGRA_0	TIOCA0	TIOCA0
	TGRB_0		TIOCB0
	TGRC_0	TIOCC0	TIOCC0
	TGRD_0		TIOCD0
1	TGRA_1	TIOCA1	TIOCA1
	TGRB_1		TIOCB1
2	TGRA_2	TIOCA2	TIOCA2
	TGRB_2		TIOCB2
3	TGRA_3	TIOCA3	TIOCA3
	TGRB_3		TIOCB3
	TGRC_3	TIOCC3	TIOCC3
	TGRD_3		TIOCD3
4	TGRA_4	TIOCA4	TIOCA4
	TGRB_4		TIOCB4
5	TGRA_5	TIOCA5	TIOCA5
	TGRB_5		TIOCB5

Note: In PWM mode 2, PWM output is not possible for the TGR register in which the cycle is set.

(1) Example of PWM Mode Setting Procedure

Figure 13.21 shows an example of the PWM mode setting procedure.

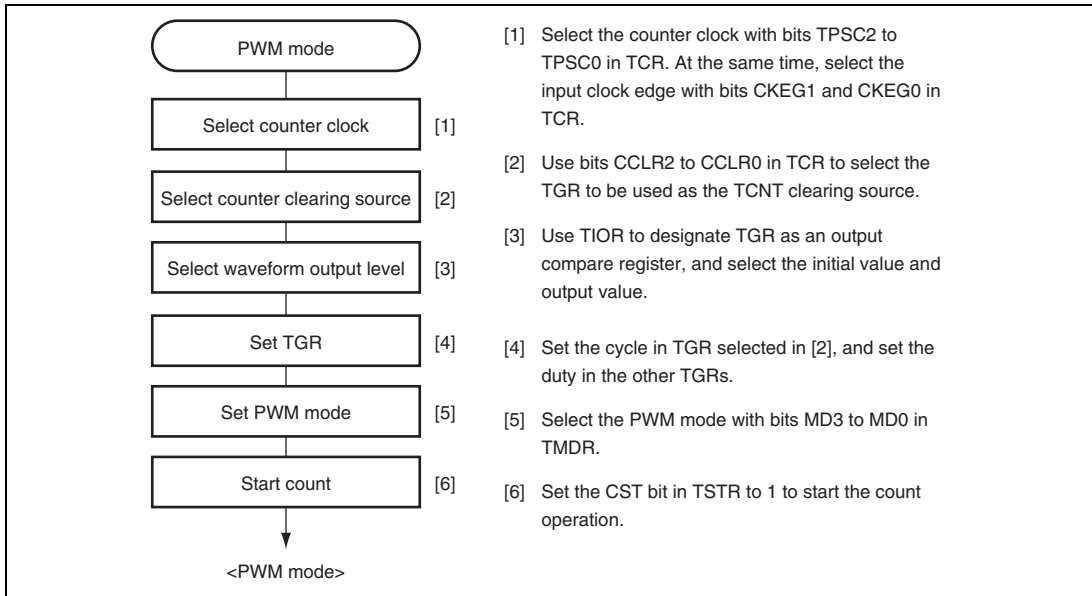

Figure 13.21 Example of PWM Mode Setting Procedure

(1) Examples of PWM Mode Operation

Figure 13.22 shows an example of PWM mode 1 operation.

In this example, TGRA compare match is set as the TCNT clearing source, 0 is set for the TGRA initial output value and output value, and 1 is set as the TGRB output value.

In this case, the value set in TGRA is used as the cycle, and the value set in TGRB register as the duty cycle.

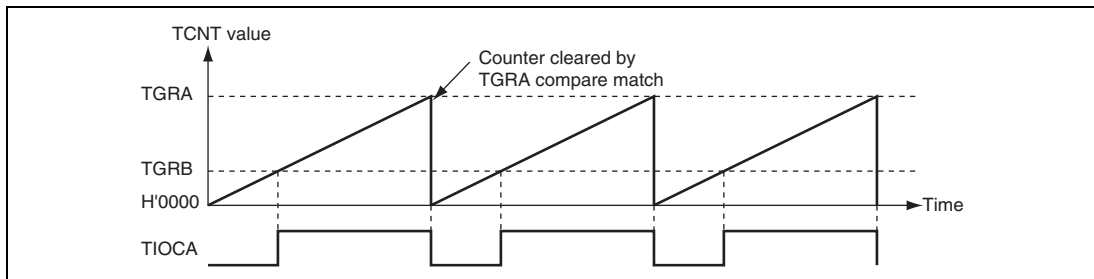

Figure 13.22 Example of PWM Mode Operation (1)

Figure 13.23 shows an example of PWM mode 2 operation.

In this example, synchronous operation is designated for channels 0 and 1, TGRB_1 compare match is set as the TCNT clearing source, and 0 is set for the initial output value and 1 for the output value of the other TGR registers (TGRA_0 to TGRD_0, TGRA_1), to output a 5-phase PWM waveform.

In this case, the value set in TGRB_1 is used as the cycle, and the values set in the other TGRs as the duty cycle.

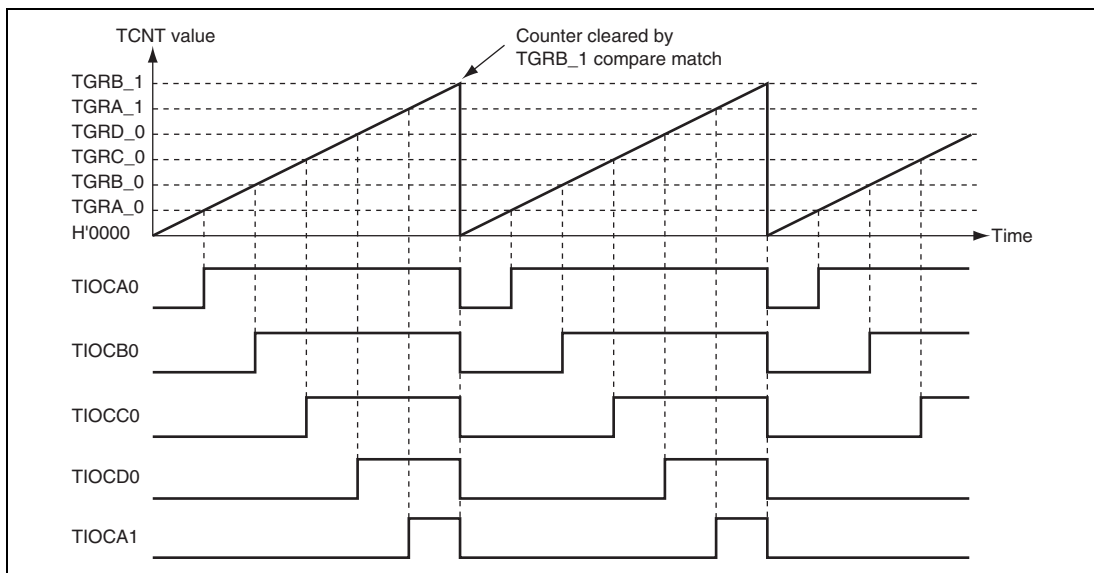

Figure 13.23 Example of PWM Mode Operation (2)

Figure 13.24 shows examples of PWM waveform output with 0% duty cycle and 100% duty cycle in PWM mode.

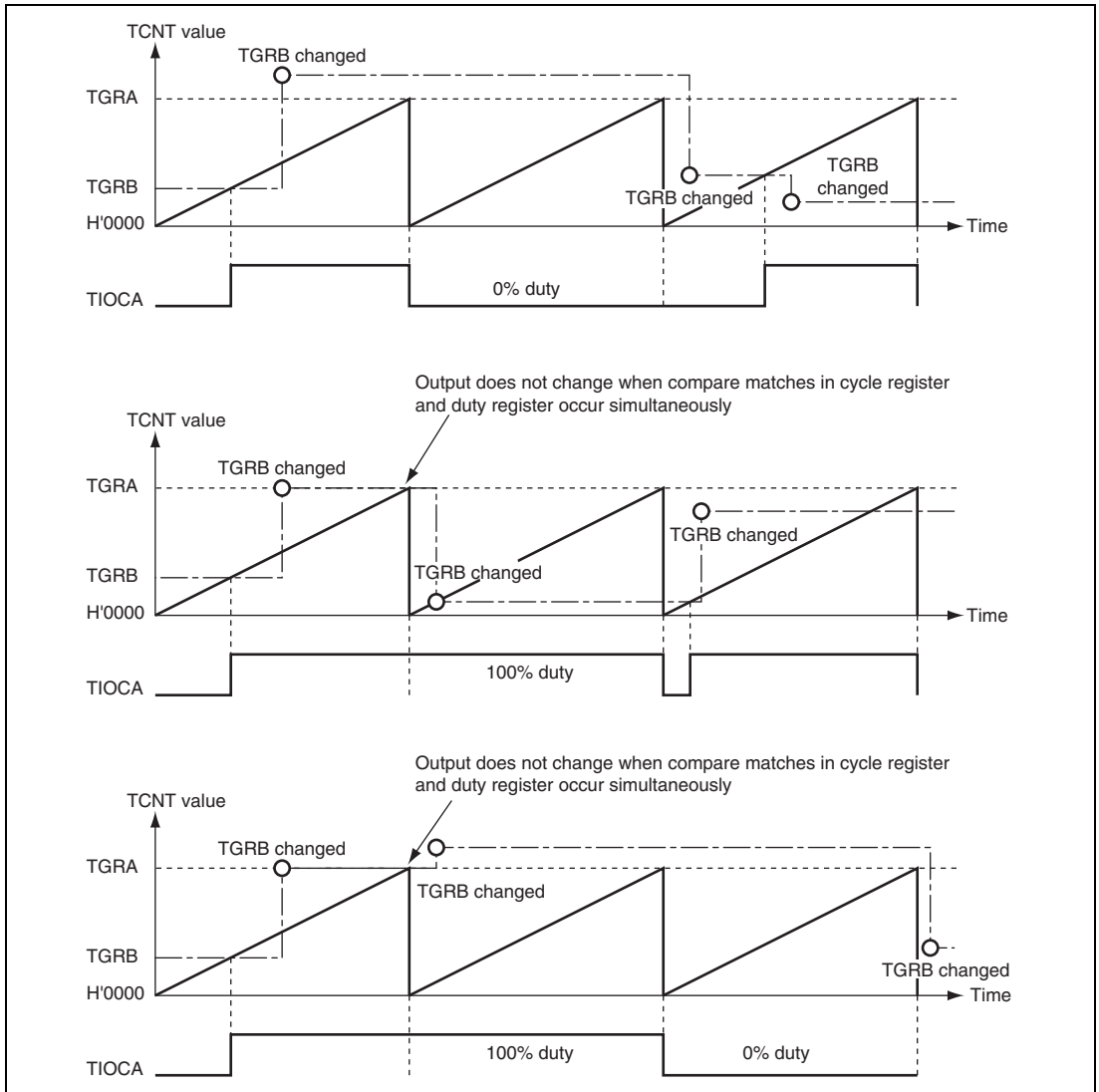

Figure 13.24 Example of PWM Mode Operation (3)

13.4.6 Phase Counting Mode

In phase counting mode, the phase difference between two external clock inputs is detected and TCNT is incremented/decremented accordingly. This mode can be set for channels 1, 2, 4, and 5.

When phase counting mode is set, an external clock is selected as the counter input clock and TCNT operates as an up/down-counter regardless of the setting of bits TPSC2 to TPSC0 and bits CKEG1 and CKEG0 in TCR. However, the functions of bits CCLR1 and CCLR0 in TCR, and of TIOR, TIER, and TGR are valid, and input capture/compare match and interrupt functions can be used.

This can be used for two-phase encoder pulse input.

When overflow occurs while TCNT is counting up, the TCFV flag in TSR is set; when underflow occurs while TCNT is counting down, the TCFU flag is set.

The TCFD bit in TSR is the count direction flag. Reading the TCFD flag provides an indication of whether TCNT is counting up or down.

Table 13.33 shows the correspondence between external clock pins and channels.

Table 13.33 Clock Input Pins in Phase Counting Mode

Channels	External Clock Pins	
	A-Phase	B-Phase
When channel 1 or 5 is set to phase counting mode	TCLKA	TCLKB
When channel 2 or 4 is set to phase counting mode	TCLKC	TCLKD

(1) Example of Phase Counting Mode Setting Procedure

Figure 13.25 shows an example of the phase counting mode setting procedure.

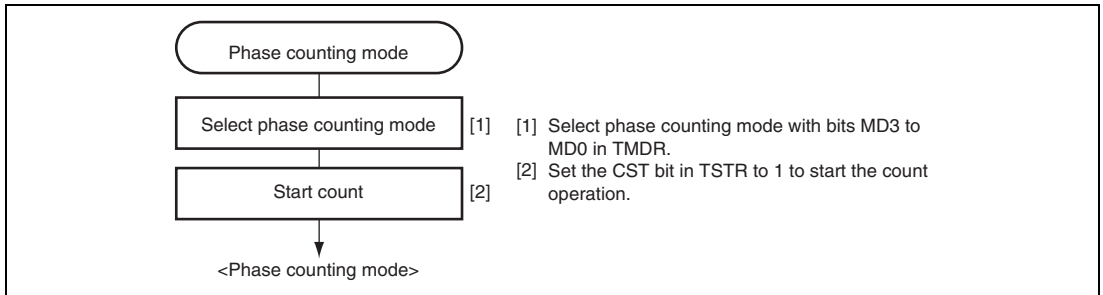

Figure 13.25 Example of Phase Counting Mode Setting Procedure

(2) Examples of Phase Counting Mode Operation

In phase counting mode, TCNT counts up or down according to the phase difference between two external clocks. There are four modes, according to the count conditions.

(a) Phase counting mode 1

Figure 13.26 shows an example of phase counting mode 1 operation, and table 13.34 summarizes the TCNT up/down-count conditions.

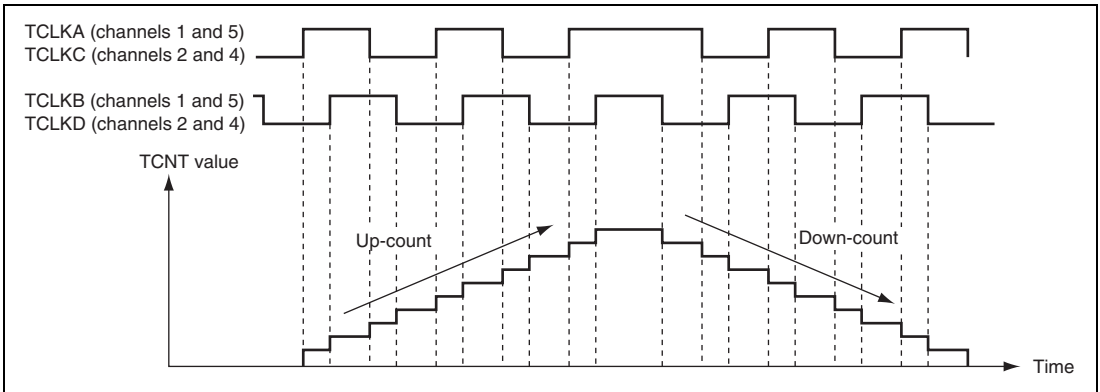

Figure 13.26 Example of Phase Counting Mode 1 Operation

Table 13.34 Up/Down-Count Conditions in Phase Counting Mode 1

TCLKA (Channels 1 and 5) TCLKC (Channels 2 and 4)	TCLKB (Channels 1 and 5) TCLKD (Channels 2 and 4)	Operation
High level		Up-count
Low level		
	Low level	Down-count
	High level	
High level		Down-count
Low level		
	High level	Up-count
	Low level	

[Legend]

: Rising edge

: Falling edge

(b) Phase counting mode 2

Figure 13.27 shows an example of phase counting mode 2 operation, and table 13.35 summarizes the TCNT up/down-count conditions.

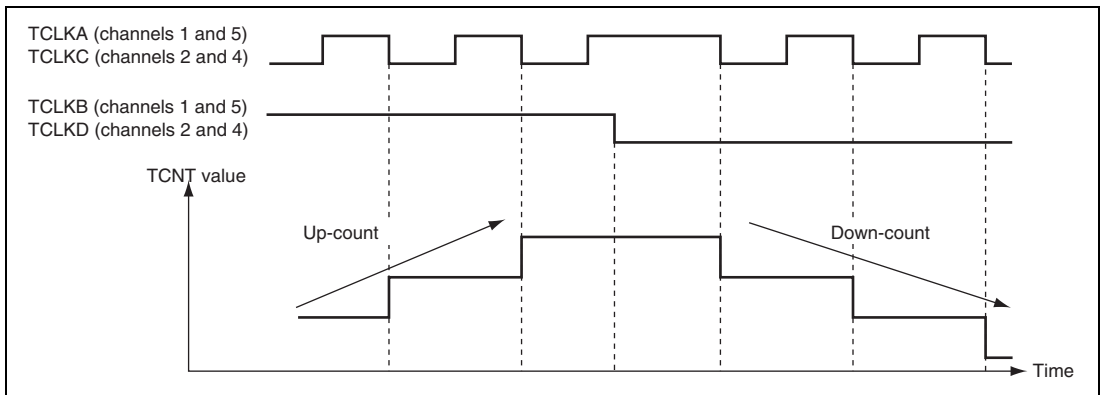

Figure 13.27 Example of Phase Counting Mode 2 Operation

Table 13.35 Up/Down-Count Conditions in Phase Counting Mode 2

TCLKA (Channels 1 and 5) TCLKC (Channels 2 and 4)	TCLKB (Channels 1 and 5) TCLKD (Channels 2 and 4)	Operation
High level	\uparrow	Don't care
Low level	\downarrow	Don't care
\uparrow	Low level	Don't care
\downarrow	High level	Up-count
High level	\downarrow	Don't care
Low level	\uparrow	Don't care
\uparrow	High level	Don't care
\downarrow	Low level	Down-count

[Legend]

\uparrow : Rising edge

\downarrow : Falling edge

(c) Phase counting mode 3

Figure 13.28 shows an example of phase counting mode 3 operation, and table 13.36 summarizes the TCNT up/down-count conditions.

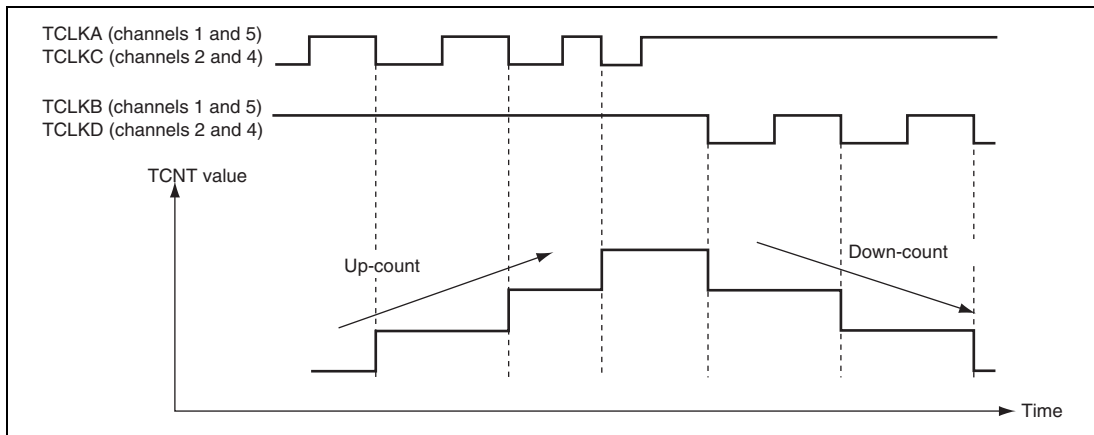

Figure 13.28 Example of Phase Counting Mode 3 Operation

Table 13.36 Up/Down-Count Conditions in Phase Counting Mode 3

TCLKA (Channels 1 and 5) TCLKC (Channels 2 and 4)	TCLKB (Channels 1 and 5) TCLKD (Channels 2 and 4)	Operation
High level	\uparrow	Don't care
Low level	\downarrow	Don't care
\uparrow	Low level	Don't care
\downarrow	High level	Up-count
High level	\downarrow	Down-count
Low level	\uparrow	Don't care
\uparrow	High level	Don't care
\downarrow	Low level	Don't care

[Legend]

\uparrow : Rising edge

\downarrow : Falling edge

(d) Phase counting mode 4

Figure 13.29 shows an example of phase counting mode 4 operation, and table 13.37 summarizes the TCNT up/down-count conditions.

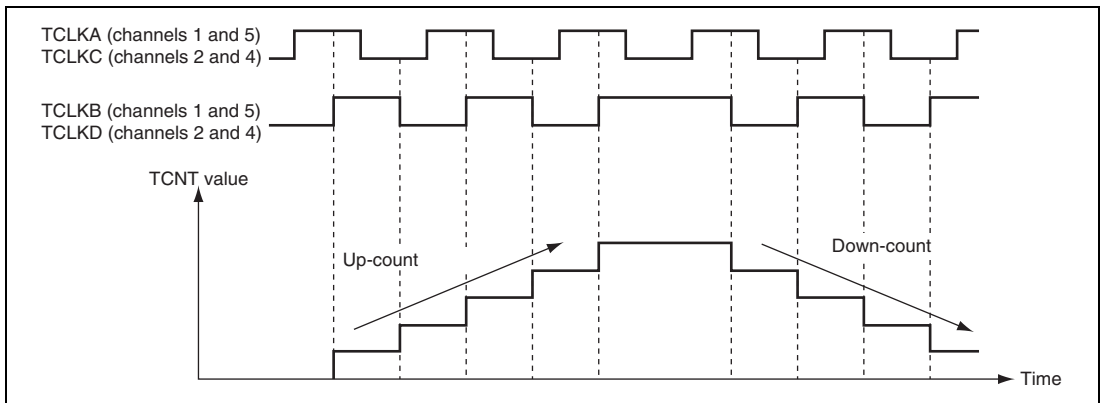

Figure 13.29 Example of Phase Counting Mode 4 Operation

Table 13.37 Up/Down-Count Conditions in Phase Counting Mode 4

TCLKA (Channels 1 and 5) TCLKC (Channels 2 and 4)	TCLKB (Channels 1 and 5) TCLKD (Channels 2 and 4)	Operation
High level	\uparrow	Up-count
Low level	\downarrow	Up-count
\uparrow	Low level	Don't care
\downarrow	High level	Don't care
High level	\downarrow	Down-count
Low level	\uparrow	Down-count
\uparrow	High level	Don't care
\downarrow	Low level	Don't care

[Legend]

\uparrow : Rising edge

\downarrow : Falling edge

(3) Phase Counting Mode Application Example

Figure 13.30 shows an example in which phase counting mode is designated for channel 1, and channel 1 is coupled with channel 0 to input servo motor 2-phase encoder pulses in order to detect the position or speed.

Channel 1 is set to phase counting mode 1, and the encoder pulse A-phase and B-phase are input to TCLKA and TCLKB.

Channel 0 operates with TCNT counter clearing by TGRC_0 compare match; TGRA_0 and TGRC_0 are used for the compare match function and are set with the speed control cycle and position control cycle. TGRB_0 is used for input capture, with TGRB_0 and TGRD_0 operating in buffer mode. The channel 1 counter input clock is designated as the TGRB_0 input capture source, and the pulse width of 2-phase encoder 4-multiplication pulses is detected.

TGRA_1 and TGRB_1 for channel 1 are designated for input capture, channel 0 TGRA_0 and TGRC_0 compare matches are selected as the input capture source, and the up/down-counter values for the control cycles are stored.

This procedure enables accurate position/speed detection to be achieved.

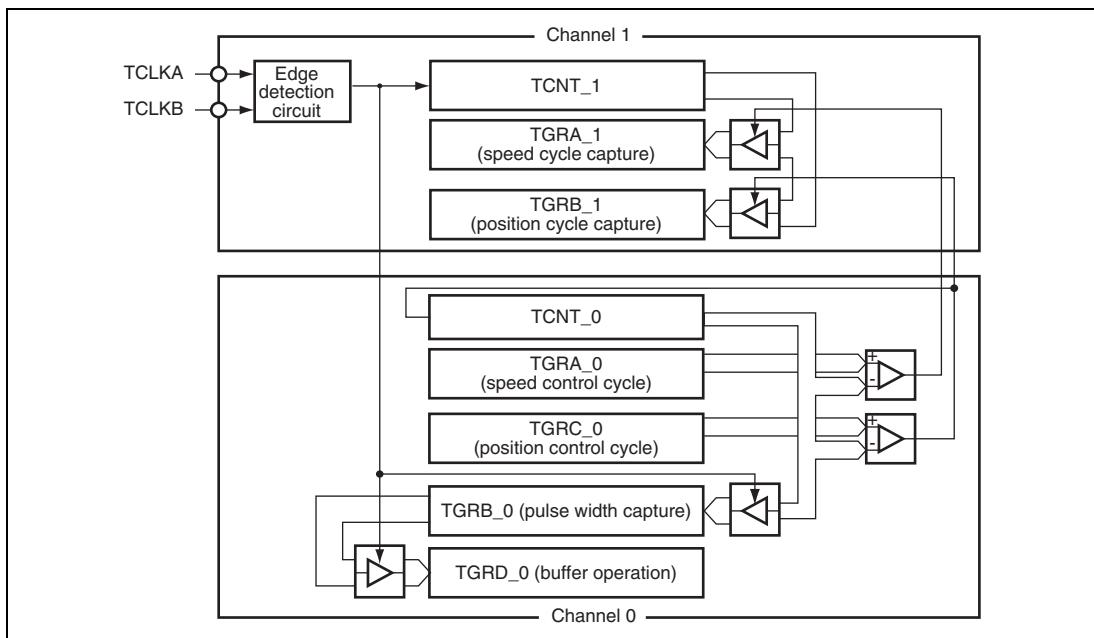

Figure 13.30 Phase Counting Mode Application Example

13.5 Interrupt Sources

There are three kinds of TPU interrupt sources: TGR input capture/compare match, TCNT overflow, and TCNT underflow. Each interrupt source has its own status flag and enable/disable bit, allowing generation of interrupt request signals to be enabled or disabled individually.

When an interrupt request is generated, the corresponding status flag in TSR is set to 1. If the corresponding enable/disable bit in TIER is set to 1 at this time, an interrupt is requested. The interrupt request is cleared by clearing the status flag to 0.

Relative channel priority levels can be changed by the interrupt controller, but the priority within a channel is fixed. For details, see section 7, Interrupt Controller.

Table 13.38 lists the TPU interrupt sources.

Table 13.38 TPU Interrupts

Channel	Name	Interrupt Source	Interrupt Flag	DTC Activation	DMAC Activation
0	TGI0A	TGRA_0 input capture/compare match	TGFA_0	Possible	Possible
	TGI0B	TGRB_0 input capture/compare match	TGFB_0	Possible	Not possible
	TGI0C	TGRC_0 input capture/compare match	TGFC_0	Possible	Not possible
	TGI0D	TGRD_0 input capture/compare match	TGFD_0	Possible	Not possible
	TCI0V	TCNT_0 overflow	TCFV_0	Not possible	Not possible
1	TGI1A	TGRA_1 input capture/compare match	TGFA_1	Possible	Possible
	TGI1B	TGRB_1 input capture/compare match	TGFB_1	Possible	Not possible
	TCI1V	TCNT_1 overflow	TCFV_1	Not possible	Not possible
	TCI1U	TCNT_1 underflow	TCFU_1	Not possible	Not possible
2	TGI2A	TGRA_2 input capture/compare match	TGFA_2	Possible	Possible
	TGI2B	TGRB_2 input capture/compare match	TGFB_2	Possible	Not possible
	TCI2V	TCNT_2 overflow	TCFV_2	Not possible	Not possible
	TCI2U	TCNT_2 underflow	TCFU_2	Not possible	Not possible
3	TGI3A	TGRA_3 input capture/compare match	TGFA_3	Possible	Possible
	TGI3B	TGRB_3 input capture/compare match	TGFB_3	Possible	Not possible
	TGI3C	TGRC_3 input capture/compare match	TGFC_3	Possible	Not possible
	TGI3D	TGRD_3 input capture/compare match	TGFD_3	Possible	Not possible
	TCI3V	TCNT_3 overflow	TCFV_3	Not possible	Not possible
4	TGI4A	TGRA_4 input capture/compare match	TGFA_4	Possible	Possible
	TGI4B	TGRB_4 input capture/compare match	TGFB_4	Possible	Not possible
	TCI4V	TCNT_4 overflow	TCFV_4	Not possible	Not possible
	TCI4U	TCNT_4 underflow	TCFU_4	Not possible	Not possible
5	TGI5A	TGRA_5 input capture/compare match	TGFA_5	Possible	Possible
	TGI5B	TGRB_5 input capture/compare match	TGFB_5	Possible	Not possible
	TCI5V	TCNT_5 overflow	TCFV_5	Not possible	Not possible
	TCI5U	TCNT_5 underflow	TCFU_5	Not possible	Not possible

Note: This table shows the initial state immediately after a reset. The relative channel priority levels can be changed by the interrupt controller.

(1) Input Capture/Compare Match Interrupt

An interrupt is requested if the TGIE bit in TIER is set to 1 when the TGF flag in TSR is set to 1 by the occurrence of a TGR input capture/compare match on a channel. The interrupt request is cleared by clearing the TGF flag to 0. The TPU has 16 input capture/compare match interrupts, four each for channels 0 and 3, and two each for channels 1, 2, 4, and 5.

(2) Overflow Interrupt

An interrupt is requested if the TCIEV bit in TIER is set to 1 when the TCFV flag in TSR is set to 1 by the occurrence of a TCNT overflow on a channel. The interrupt request is cleared by clearing the TCFV flag to 0. The TPU has six overflow interrupts, one for each channel.

(3) Underflow Interrupt

An interrupt is requested if the TCIEU bit in TIER is set to 1 when the TCFU flag in TSR is set to 1 by the occurrence of a TCNT underflow on a channel. The interrupt request is cleared by clearing the TCFU flag to 0. The TPU has four underflow interrupts, one each for channels 1, 2, 4, and 5.

13.6 DTC Activation

The DTC can be activated by the TGR input capture/compare match interrupt for a channel. For details, see section 11, Data Transfer Controller (DTC).

A total of 16 TPU input capture/compare match interrupts can be used as DTC activation sources, four each for channels 0 and 3, and two each for channels 1, 2, 4, and 5.

13.7 DMAC Activation

The DMAC can be activated by the TGRA input capture/compare match interrupt for a channel. For details, see section 10, DMA Controller (DMAC).

In TPU, one in each channel, totally six TGRA input capture/compare match interrupts can be used as DMAC activation sources.

13.8 A/D Converter Activation

Concerning the unit 0 in TPU, the TGRA input capture/compare match for each channel can activate the A/D converter. (However, the A/D converter cannot be activated in unit 1.)

If the TTGE bit in TIER is set to 1 when the TGFA flag in TSR is set to 1 by the occurrence of a TGRA input capture/compare match on a particular channel, a request to start A/D conversion is sent to the A/D converter. If the TPU conversion start trigger has been selected on the A/D converter side at this time, A/D conversion is started.

In the TPU, a total of six TGRA input capture/compare match interrupts can be used as A/D converter conversion start sources, one for each channel.

13.9 Operation Timing

13.9.1 Input/Output Timing

(1) TCNT Count Timing

Figure 13.31 shows TCNT count timing in internal clock operation, and Figure 13.32 shows TCNT count timing in external clock operation.

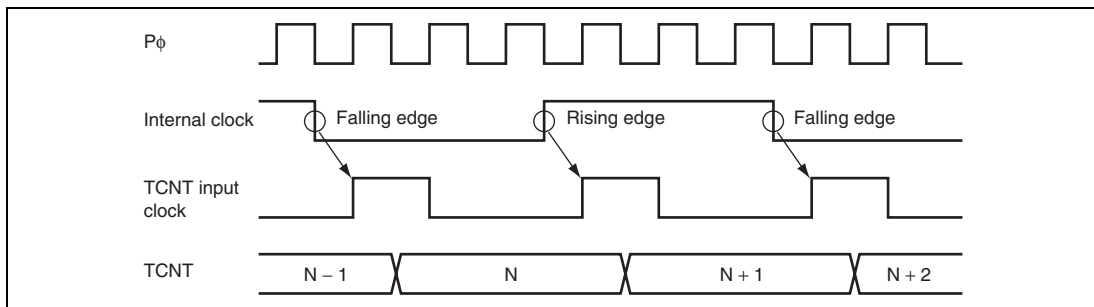

Figure 13.31 Count Timing in Internal Clock Operation

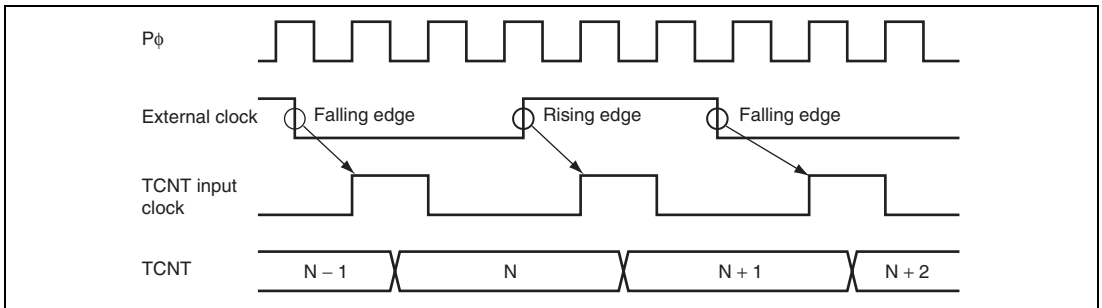

Figure 13.32 Count Timing in External Clock Operation

(2) Output Compare Output Timing

A compare match signal is generated in the final state in which TCNT and TGR match (the point at which the count value matched by TCNT is updated). When a compare match signal is generated, the output value set in TIOR is output at the output compare output pin (TIOC pin). After a match between TCNT and TGR, the compare match signal is not generated until the TCNT input clock is generated.

Figure 13.33 shows output compare output timing.

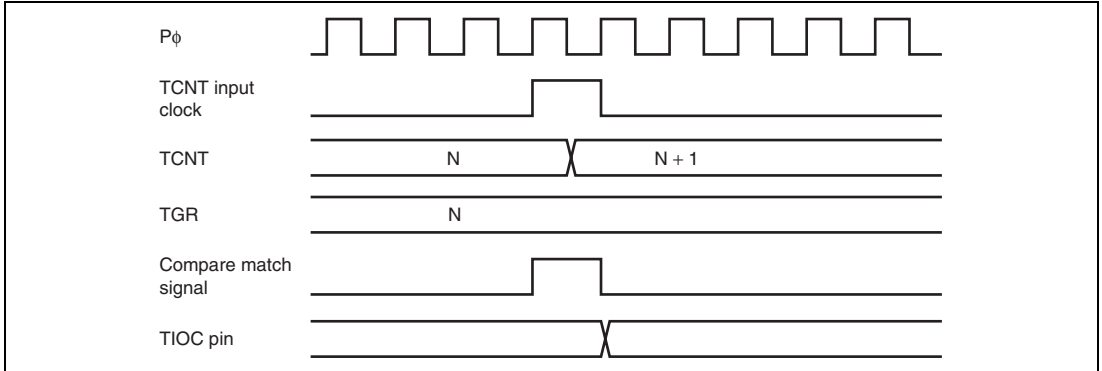

Figure 13.33 Output Compare Output Timing

(3) Input Capture Signal Timing

Figure 13.34 shows input capture signal timing.

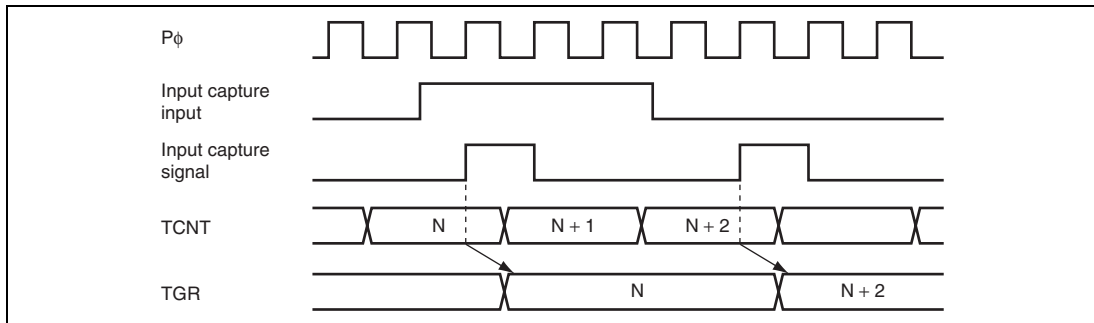

Figure 13.34 Input Capture Input Signal Timing

(4) Timing for Counter Clearing by Compare Match/Input Capture

Figure 13.35 shows the timing when counter clearing by compare match occurrence is specified, and Figure 13.36 shows the timing when counter clearing by input capture occurrence is specified.

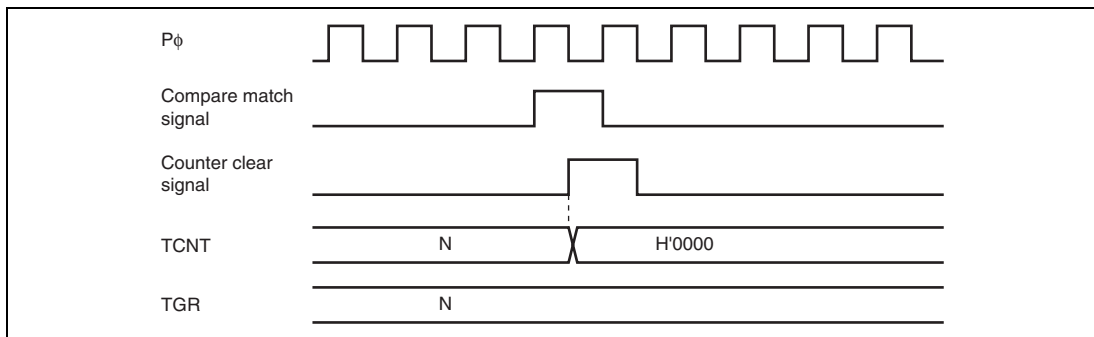

Figure 13.35 Counter Clear Timing (Compare Match)

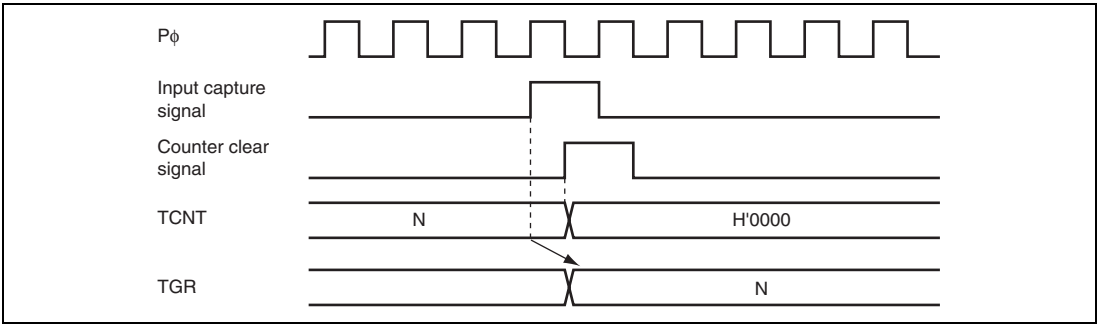

Figure 13.36 Counter Clear Timing (Input Capture)

(5) Buffer Operation Timing

Figures 13.37 and 13.38 show the timings in buffer operation.

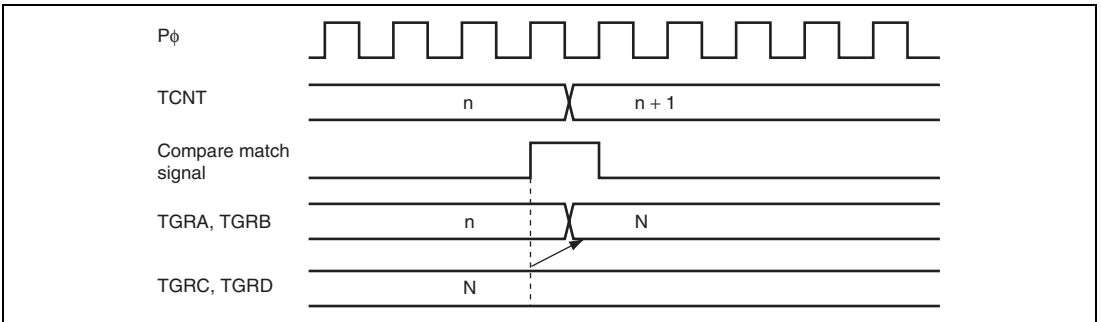

Figure 13.37 Buffer Operation Timing (Compare Match)

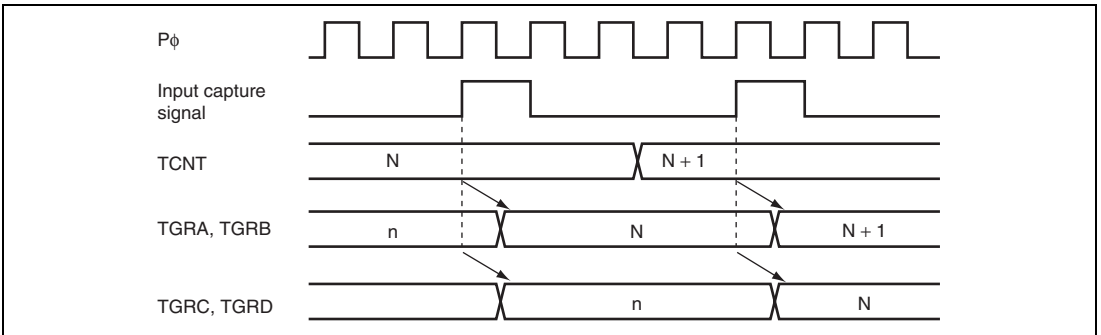

Figure 13.38 Buffer Operation Timing (Input Capture)

13.9.2 Interrupt Signal Timing

(1) TGF Flag Setting Timing in Case of Compare Match

Figure 13.39 shows the timing for setting of the TGF flag in TSR by compare match occurrence, and the TGI interrupt request signal timing.

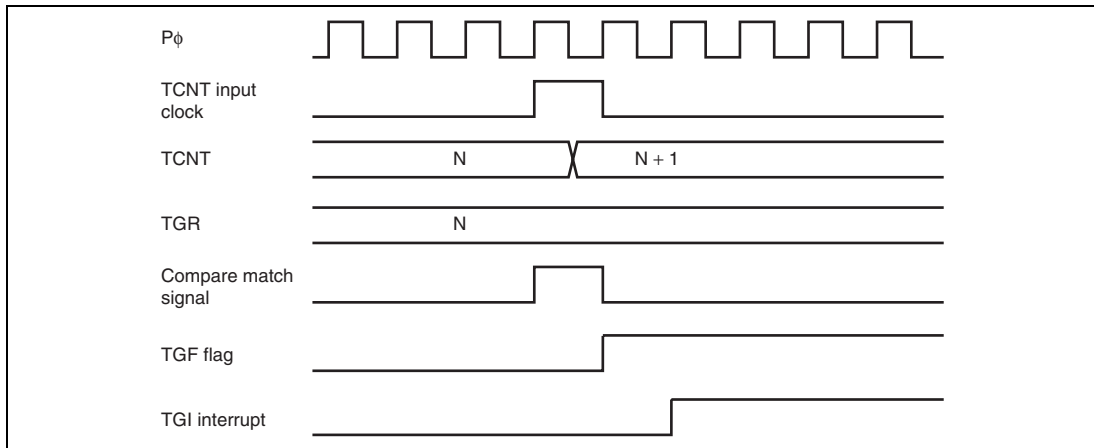

Figure 13.39 TGI Interrupt Timing (Compare Match)

(2) TGF Flag Setting Timing in Case of Input Capture

Figure 13.40 shows the timing for setting of the TGF flag in TSR by input capture occurrence, and the TGI interrupt request signal timing.

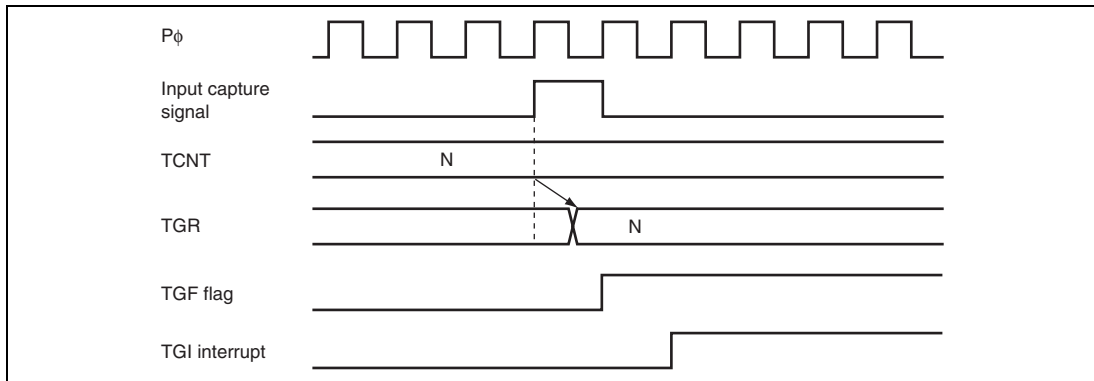

Figure 13.40 TGI Interrupt Timing (Input Capture)

(3) TCFV Flag/TCFU Flag Setting Timing

Figure 13.41 shows the timing for setting of the TCFV flag in TSR by overflow occurrence, and the TCIV interrupt request signal timing.

Figure 13.42 shows the timing for setting of the TCFU flag in TSR by underflow occurrence, and the TCIU interrupt request signal timing.

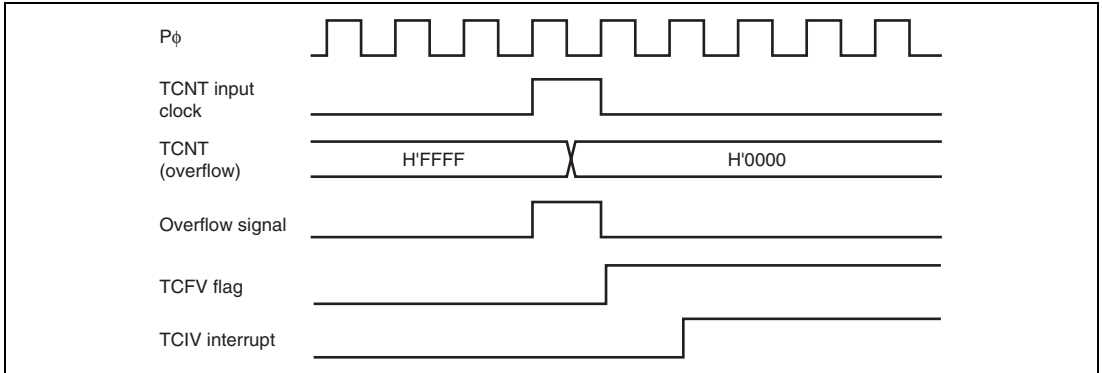

Figure 13.41 TCIV Interrupt Setting Timing

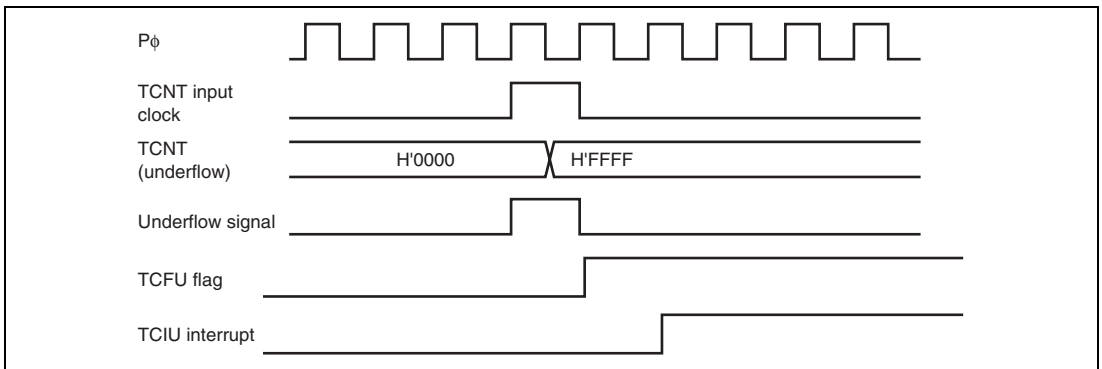

Figure 13.42 TCIU Interrupt Setting Timing

(4) Status Flag Clearing Timing

After a status flag is read as 1 by the CPU, it is cleared by writing 0 to it. When the DTC or DMAC is activated, the flag is cleared automatically. Figure 13.43 shows the timing for status flag clearing by the CPU, and figures 13.44 and 13.45 show the timing for status flag clearing by the DTC or DMAC.

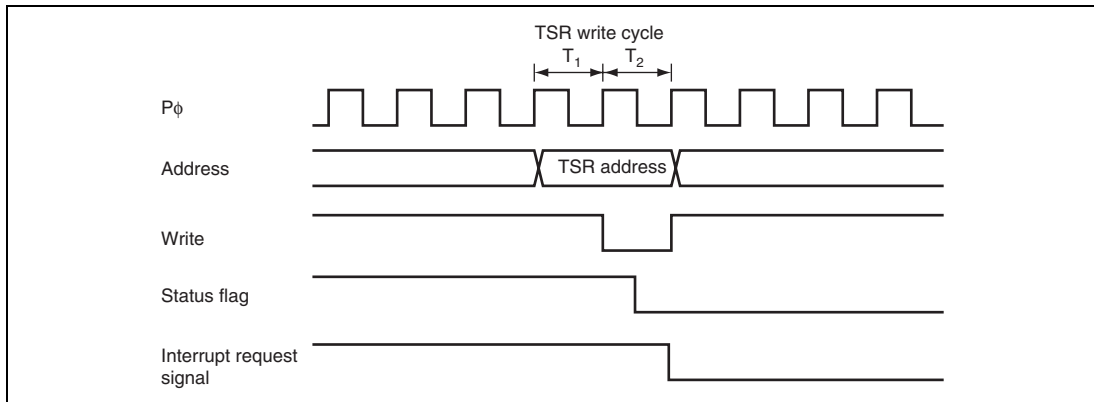

Figure 13.43 Timing for Status Flag Clearing by CPU

The status flag and interrupt request signal are cleared in synchronization with $P\phi$ after the DTC or DMAC transfer has started, as shown in Figure 13.44. If conflict occurs for clearing the status flag and interrupt request signal due to activation of multiple DTC or DMAC transfers, it will take up to five clock cycles ($P\phi$) for clearing them, as shown in Figure 13.45. The next transfer request is masked for a longer period of either a period until the current transfer ends or a period for five clock cycles ($P\phi$) from the beginning of the transfer. Note that in the DTC transfer, the status flag may be cleared during outputting the destination address.

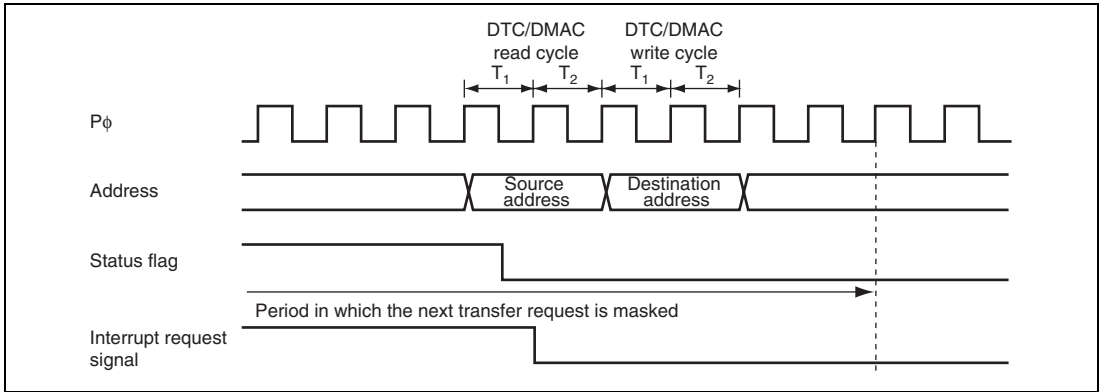

Figure 13.44 Timing for Status Flag Clearing by DTC/DMAC Activation (1)

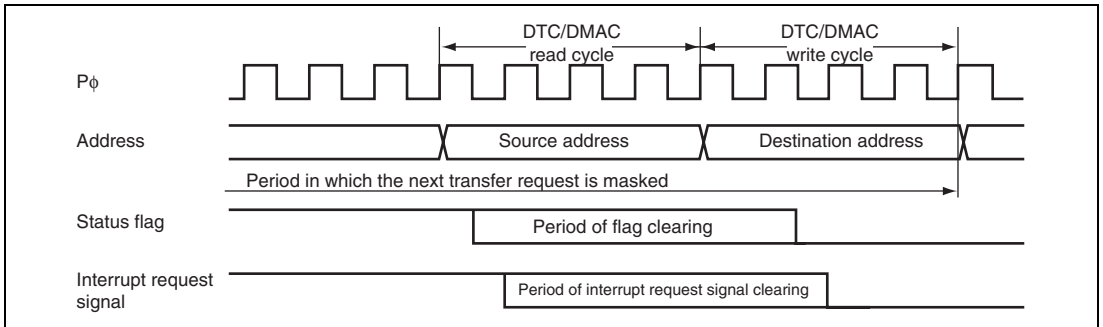

Figure 13.45 Timing for Status Flag Clearing by DTC/DMAC Activation (2)

13.10 Usage Notes

13.10.1 Module Stop Function Setting

Operation of the TPU can be disabled or enabled using the module stop control register. The initial setting is for operation of the TPU to be halted. Register access is enabled by clearing module stop state. For details, see section 25, Power-Down Modes.

13.10.2 Input Clock Restrictions

The input clock pulse width must be at least 1.5 states in the case of single-edge detection, and at least 2.5 states in the case of both-edge detection. The TPU will not operate properly with a narrower pulse width.

In phase counting mode, the phase difference and overlap between the two input clocks must be at least 1.5 states, and the pulse width must be at least 2.5 states. Figure 13.46 shows the input clock conditions in phase counting mode.

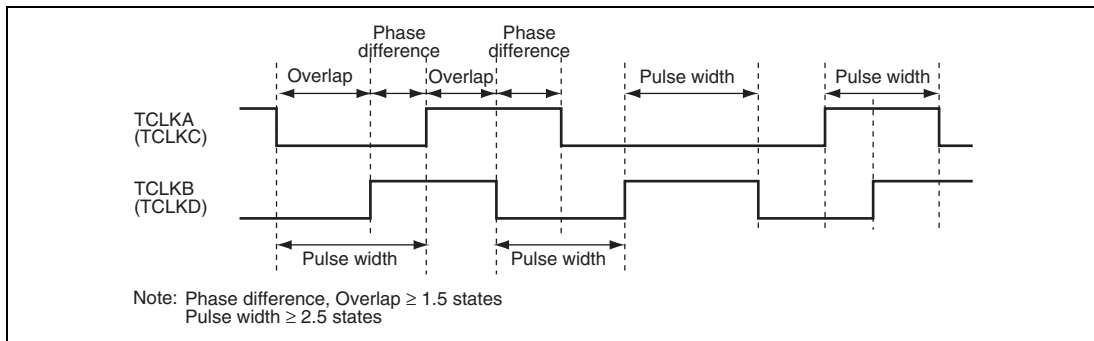

Figure 13.46 Phase Difference, Overlap, and Pulse Width in Phase Counting Mode

13.10.3 Caution on Cycle Setting

When counter clearing by compare match is set, TCNT is cleared in the final state in which it matches the TGR value (the point at which the count value matched by TCNT is updated). Consequently, the actual counter frequency is given by the following formula:

$$f = \frac{P\phi}{(N + 1)}$$

- f: Counter frequency
- P ϕ : Operating frequency
- N: TGR set value

13.10.4 Conflict between TCNT Write and Clear Operations

If the counter clearing signal is generated in the T2 state of a TCNT write cycle, TCNT clearing takes precedence and the TCNT write is not performed. Figure 13.47 shows the timing in this case.

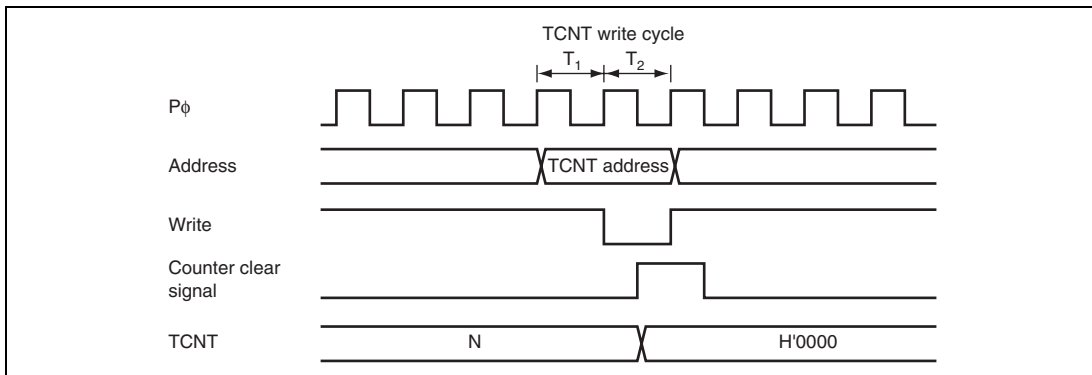

Figure 13.47 Conflict between TCNT Write and Clear Operations

13.10.5 Conflict between TCNT Write and Increment Operations

If incrementing occurs in the T2 state of a TCNT write cycle, the TCNT write takes precedence and TCNT is not incremented. Figure 13.48 shows the timing in this case.

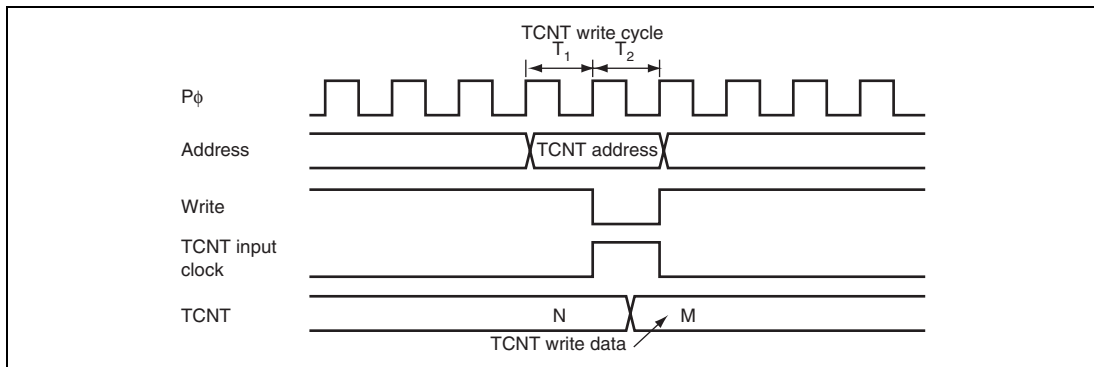

Figure 13.48 Conflict between TCNT Write and Increment Operations

13.10.6 Conflict between TGR Write and Compare Match

If a compare match occurs in the T2 state of a TGR write cycle, the TGR write takes precedence and the compare match signal is disabled. A compare match also does not occur when the same value as before is written.

Figure 13.49 shows the timing in this case.

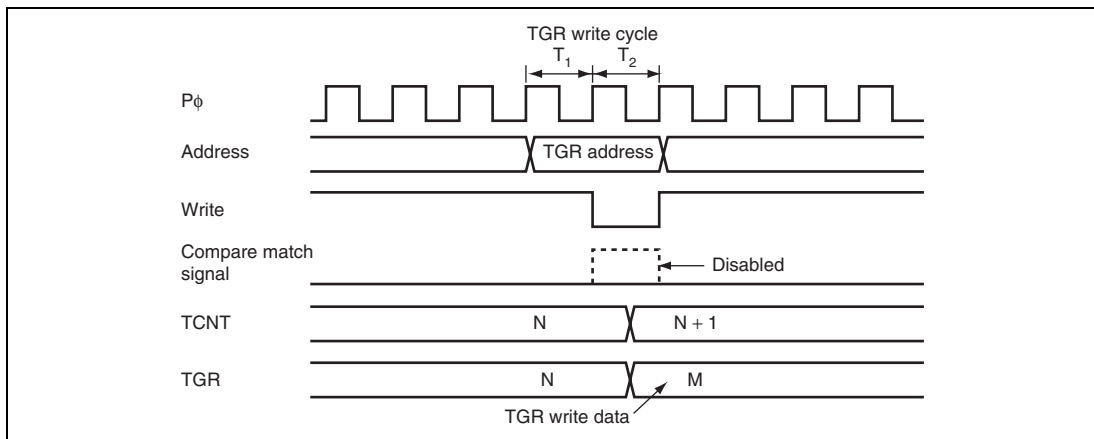

Figure 13.49 Conflict between TGR Write and Compare Match

13.10.7 Conflict between Buffer Register Write and Compare Match

If a compare match occurs in the T2 state of a TGR write cycle, the data transferred to TGR by the buffer operation will be the write data.

Figure 13.50 shows the timing in this case.

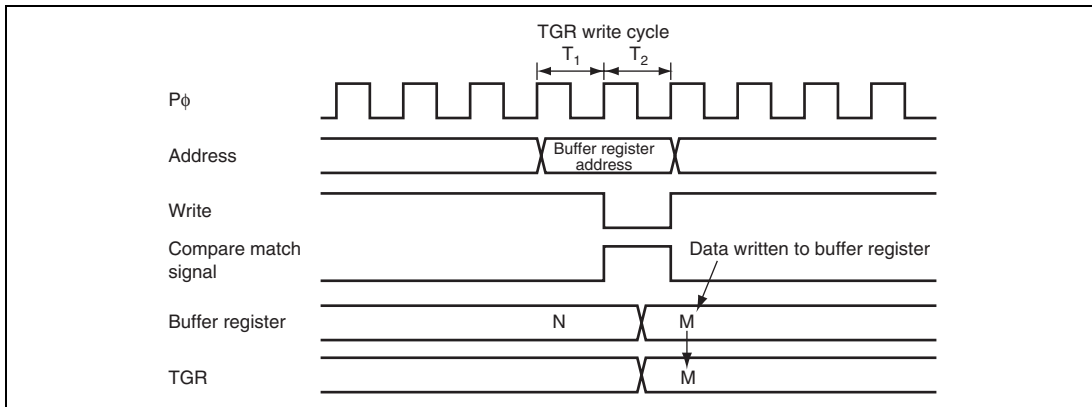

Figure 13.50 Conflict between Buffer Register Write and Compare Match

13.10.8 Conflict between TGR Read and Input Capture

If the input capture signal is generated in the T1 state of a TGR read cycle, the data that is read will be the data after input capture transfer.

Figure 13.51 shows the timing in this case.

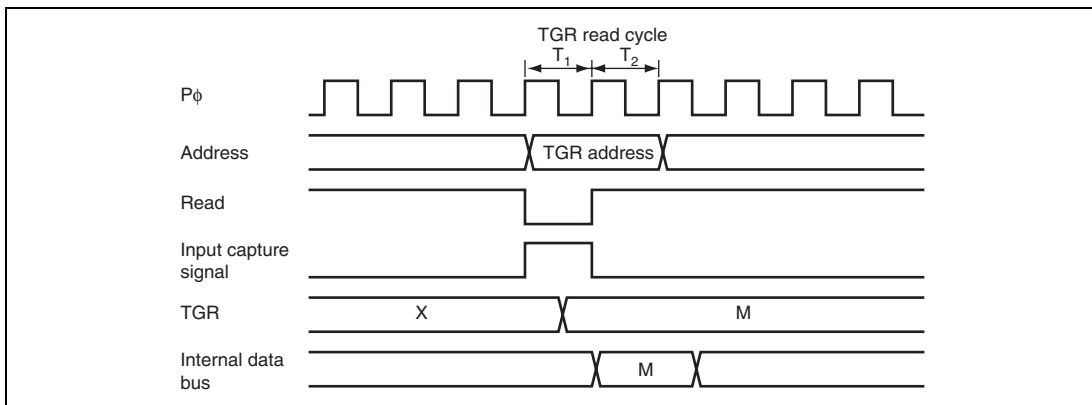

Figure 13.51 Conflict between TGR Read and Input Capture

13.10.9 Conflict between TGR Write and Input Capture

If the input capture signal is generated in the T2 state of a TGR write cycle, the input capture operation takes precedence and the write to TGR is not performed.

Figure 13.52 shows the timing in this case.

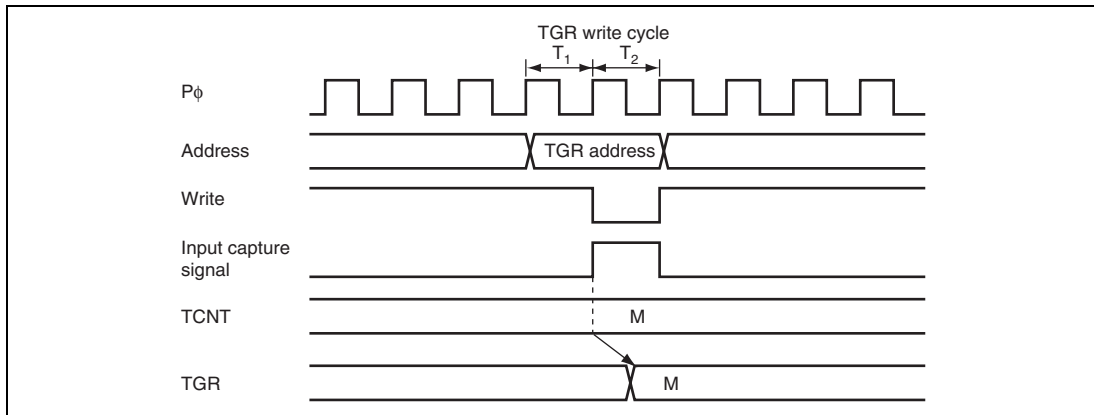

Figure 13.52 Conflict between TGR Write and Input Capture

13.10.10 Conflict between Buffer Register Write and Input Capture

If the input capture signal is generated in the T2 state of a buffer register write cycle, the buffer operation takes precedence and the write to the buffer register is not performed.

Figure 13.53 shows the timing in this case.

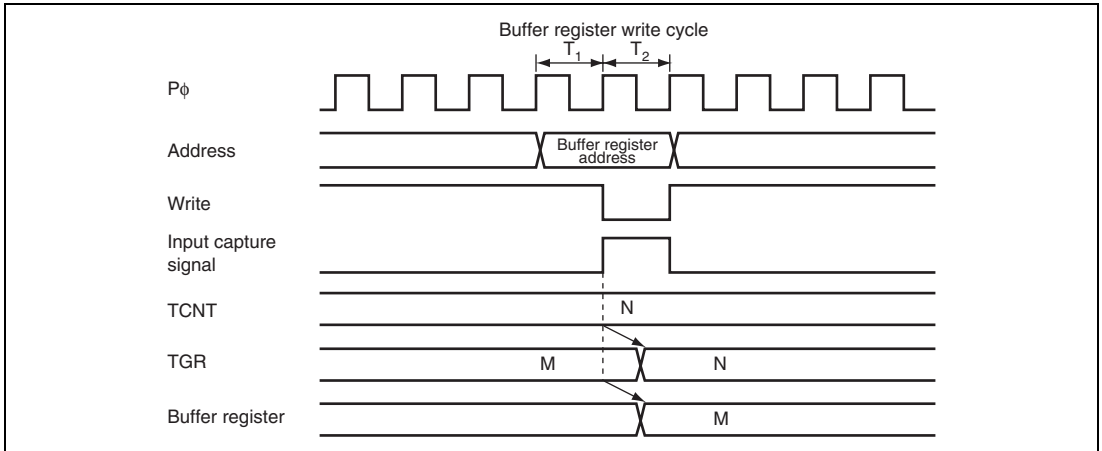

Figure 13.53 Conflict between Buffer Register Write and Input Capture

13.10.11 Conflict between Overflow/Underflow and Counter Clearing

If overflow/underflow and counter clearing occur simultaneously, the TCFV/TCFU flag in TSR is not set and TCNT clearing takes precedence.

Figure 13.54 shows the operation timing when a TGR compare match is specified as the clearing source, and H'FFFF is set in TGR.

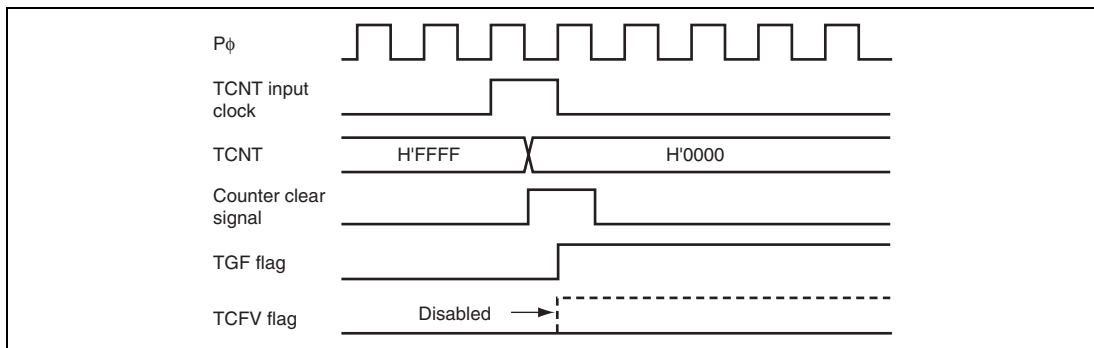

Figure 13.54 Conflict between Overflow and Counter Clearing

13.10.12 Conflict between TCNT Write and Overflow/Underflow

If an overflow/underflow occurs due to increment/decrement in the T2 state of a TCNT write cycle, the TCNT write takes precedence and the TCFV/TCFU flag in TSR is not set.

Figure 13.55 shows the operation timing when there is conflict between TCNT write and overflow.

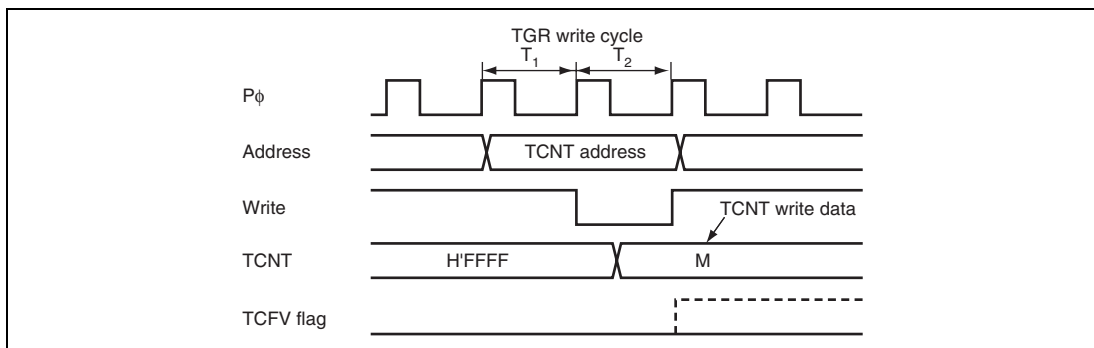

Figure 13.55 Conflict between TCNT Write and Overflow

13.10.13 Multiplexing of I/O Pins

In this LSI, the TCLKA input pin is multiplexed with the TIOCC0 I/O pin, the TCLKB input pin with the TIOCD0 I/O pin, the TCLKC input pin with the TIOCB1 I/O pin, and the TCLKD input pin with the TIOCB2 I/O pin. When an external clock is input, compare match output should not be performed from a multiplexed pin.

13.10.14 PPG1 Setting when TPU1 Pin is Used

When the TPU1 pin is used, the NDER bit of the PPG1 pin multiplexed with the TPU1 pin should be cleared to halt the output. For details, see section 12, I/O Ports.

13.10.15 Interrupts and Module Stop Mode

If module stop state is entered when an interrupt has been requested, it will not be possible to clear the CPU interrupt source or the DTC and DMAC activation sources. Interrupts should therefore be disabled before entering module stop state.

Section 14 Programmable Pulse Generator (PPG)

The programmable pulse generator (PPG) provides pulse outputs by using the 16-bit timer pulse unit (TPU) as a time base. The PPG pulse outputs are divided into 4-bit groups (groups 3 to 0) that can operate both simultaneously and independently. Figures 14.1 and 14.2 show a block diagram of the PPG.

14.1 Features

- 32-bit output data
- Four output groups
- Selectable output trigger signals
- Non-overlapping mode
- Can operate together with the data transfer controller (DTC) and DMA controller (DMAC)
- Inverted output can be set
- Module stop state specifiable

Table 14.1 List of PPG Functions

	Function	PPG0	PPG1	
PPG output trigger	TPU0	Compare match	Possible	Not possible
		Input capture	Possible	Not possible
	TPU1	Compare match	Not possible	Possible
		Input capture	Not possible	Not possible
Non-overlapping mode		Possible	Possible	
Output data transfer	DTC	Possible	Possible	
	DMAC	Possible	Possible	
Inverted output		Possible	Possible	

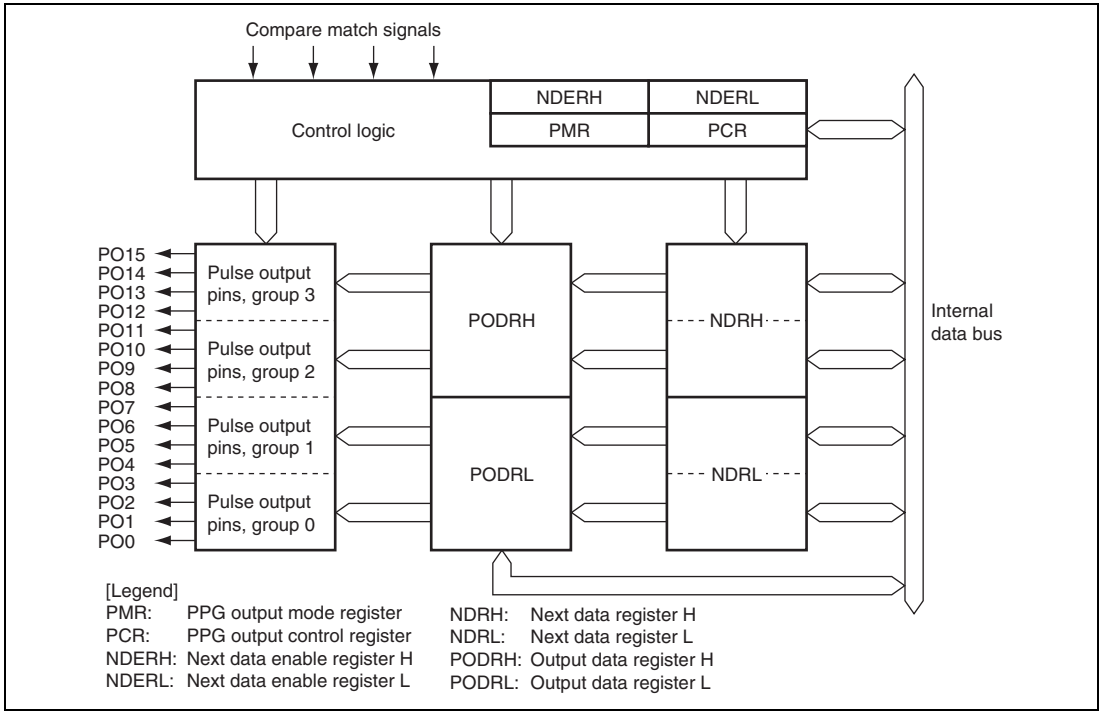

Figure 14.1 Block Diagram of PPG (Unit 0)

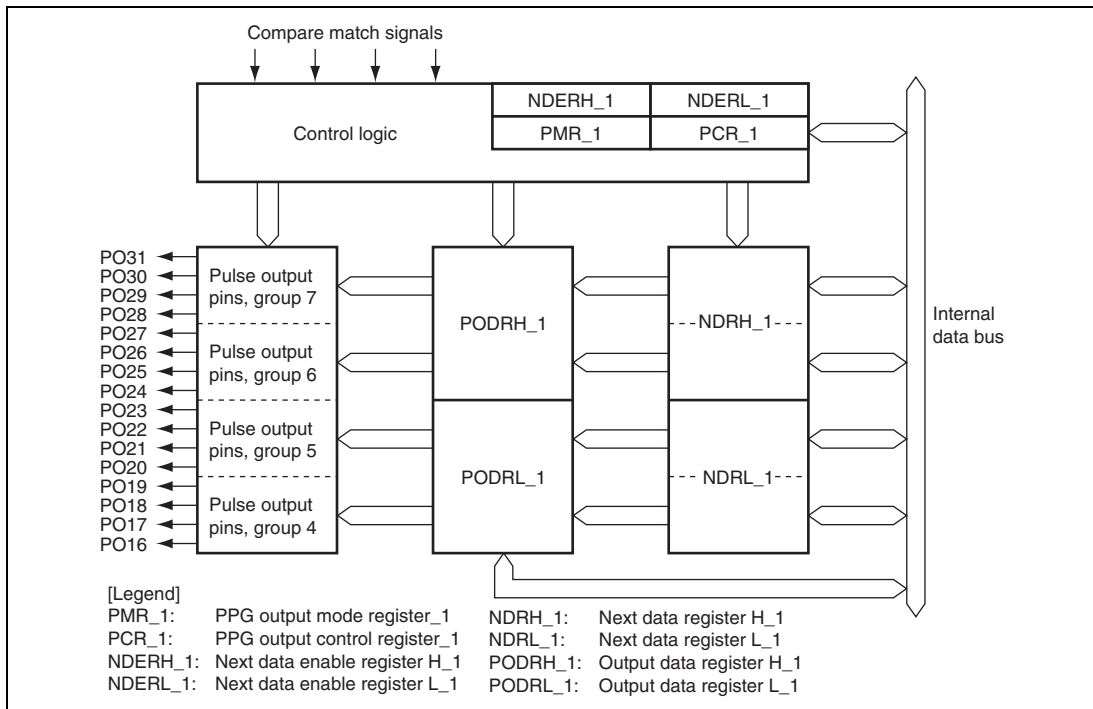

Figure 14.2 Block Diagram of PPG (Unit 1)

14.2 Input/Output Pins

Table 14.2 shows the PPG pin configuration.

Table 14.2 Pin Configuration

Unit	Pin Name	I/O	Function
0	PO0	Output	Group 0 pulse output
	PO1	Output	
	PO2	Output	
	PO3	Output	
	PO4	Output	Group 1 pulse output
	PO5	Output	
	PO6	Output	
	PO7	Output	
	PO8	Output	Group 2 pulse output
	PO9	Output	
	PO10	Output	
	PO11	Output	
	PO12	Output	Group 3 pulse output
	PO13	Output	
	PO14	Output	
	PO15	Output	

Unit	Pin Name	I/O	Function
1	PO16	Output	Group 4 pulse output
	PO17	Output	
	PO18	Output	
	PO19	Output	
	PO20	Output	Group 5 pulse output
	PO21	Output	
	PO22	Output	
	PO23	Output	
	PO24	Output	Group 6 pulse output
	PO25	Output	
	PO26	Output	
	PO27	Output	
	PO28	Output	Group 7 pulse output
	PO29	Output	
	PO30	Output	
	PO31	Output	

14.3 Register Descriptions

The PPG has the following registers.

Unit 0:

- Next data enable register H (NDERH)
- Next data enable register L (NDERL)
- Output data register H (PODRH)
- Output data register L (PODRL)
- Next data register H (NDRH)
- Next data register L (NDRL)
- PPG output control register (PCR)
- PPG output mode register (PMR)

Unit 1:

- Next data enable register H_1 (NDERH_1)
- Next data enable register L_1 (NDERL_1)
- Output data register H_1 (PODRH_1)
- Output data register L_1 (PODRL_1)
- Next data register H_1 (NDRH_1)
- Next data register L_1 (NDRL_1)
- PPG output control register_1 (PCR_1)
- PPG output mode register_1 (PMR_1)

14.3.1 Next Data Enable Registers H, L (NDERH, NDERL)

NDERH and NDERL enable/disable pulse output on a bit-by-bit basis.

- NDERH

Bit	7	6	5	4	3	2	1	0
Bit Name	NDER15	NDER14	NDER13	NDER12	NDER11	NDER10	NDER9	NDER8
Initial Value	0	0	0	0	0	0	0	0
R/W	R/W	R/W	R/W	R/W	R/W	R/W	R/W	R/W

- NDERL

Bit	7	6	5	4	3	2	1	0
Bit Name	NDER7	NDER6	NDER5	NDER4	NDER3	NDER2	NDER1	NDER0
Initial Value	0	0	0	0	0	0	0	0
R/W	R/W	R/W	R/W	R/W	R/W	R/W	R/W	R/W

- NDERH

Bit	Bit Name	Initial Value	R/W	Description
7	NDER15	0	R/W	Next Data Enable 15 to 8
6	NDER14	0	R/W	When a bit is set to 1, the value in the corresponding NDRH bit is transferred to the PODRH bit by the selected output trigger. Values are not transferred from NDRH to PODRH for cleared bits.
5	NDER13	0	R/W	
4	NDER12	0	R/W	
3	NDER11	0	R/W	
2	NDER10	0	R/W	
1	NDER9	0	R/W	
0	NDER8	0	R/W	

- NDERL

Bit	Bit Name	Initial Value	R/W	Description
7	NDER7	0	R/W	Next Data Enable 7 to 0
6	NDER6	0	R/W	When a bit is set to 1, the value in the corresponding NDRL bit is transferred to the PODRL bit by the selected output trigger. Values are not transferred from NDRL to PODRL for cleared bits.
5	NDER5	0	R/W	
4	NDER4	0	R/W	
3	NDER3	0	R/W	
2	NDER2	0	R/W	
1	NDER1	0	R/W	
0	NDER0	0	R/W	

- NDERH_1

Bit	Bit Name	Initial Value	R/W	Description
7	NDER31	0	R/W	Next Data Enable 31 to 24
6	NDER30	0	R/W	When a bit is set to 1, the value in the corresponding NDRH_1 bit is transferred to the PODRH_1 bit by the selected output trigger. Values are not transferred from NDRH_1 to PODRH_1 for cleared bits.
5	NDER29	0	R/W	
4	NDER28	0	R/W	
3	NDER27	0	R/W	
2	NDER26	0	R/W	
1	NDER25	0	R/W	
0	NDER24	0	R/W	

- NDERL_1

Bit	Bit Name	Initial Value	R/W	Description
7	NDER23	0	R/W	Next Data Enable 23 to 16
6	NDER22	0	R/W	When a bit is set to 1, the value in the corresponding NDRL_1 bit is transferred to the PODRL_1 bit by the selected output trigger. Values are not transferred from NDRL_1 to PODRL_1 for cleared bits.
5	NDER21	0	R/W	
4	NDER20	0	R/W	
3	NDER19	0	R/W	
2	NDER18	0	R/W	
1	NDER17	0	R/W	
0	NDER16	0	R/W	

14.3.2 Output Data Registers H, L (PODRH, PODRL)

PODRH and PODRL store output data for use in pulse output. A bit that has been set for pulse output by NDER is read-only and cannot be modified.

- PODRH

Bit	7	6	5	4	3	2	1	0
Bit Name	POD15	POD14	POD13	POD12	POD11	POD10	POD9	POD8
Initial Value	0	0	0	0	0	0	0	0
R/W	R/W	R/W	R/W	R/W	R/W	R/W	R/W	R/W

- PODRL

Bit	7	6	5	4	3	2	1	0
Bit Name	POD7	POD6	POD5	POD4	POD3	POD2	POD1	POD0
Initial Value	0	0	0	0	0	0	0	0
R/W	R/W	R/W	R/W	R/W	R/W	R/W	R/W	R/W

- PODRH

Bit	Bit Name	Initial Value	R/W	Description
7	POD15	0	R/W	Output Data Register 15 to 8
6	POD14	0	R/W	For bits which have been set to pulse output by NDERH, the output trigger transfers NDRH values to this register during PPG operation. While NDERH is set to 1, the CPU cannot write to this register. While NDERH is cleared, the initial output value of the pulse can be set.
5	POD13	0	R/W	
4	POD12	0	R/W	
3	POD11	0	R/W	
2	POD10	0	R/W	
1	POD9	0	R/W	
0	POD8	0	R/W	

- PODRL

Bit	Bit Name	Initial Value	R/W	Description
7	POD7	0	R/W	Output Data Register 7 to 0
6	POD6	0	R/W	For bits which have been set to pulse output by NDERL, the output trigger transfers NDRL values to this register during PPG operation. While NDERL is set to 1, the CPU cannot write to this register. While NDERL is cleared, the initial output value of the pulse can be set.
5	POD5	0	R/W	
4	POD4	0	R/W	
3	POD3	0	R/W	
2	POD2	0	R/W	
1	POD1	0	R/W	
0	POD0	0	R/W	

- PODRH_1

Bit	Bit Name	Initial Value	R/W	Description
7	POD31	0	R/W	Output Data Register 31 to 24
6	POD30	0	R/W	For bits which have been set to pulse output by NDERH_1, the output trigger transfers NDRH_1 values to this register during PPG operation. While NDERH_1 is set to 1, the CPU cannot write to this register. While NDERH_1 is cleared, the initial output value of the pulse can be set.
5	POD29	0	R/W	
4	POD28	0	R/W	
3	POD27	0	R/W	
2	POD26	0	R/W	
1	POD25	0	R/W	
0	POD24	0	R/W	

- PODRL_1

Bit	Bit Name	Initial Value	R/W	Description
7	POD23	0	R/W	Output Data Register 23 to 16
6	POD22	0	R/W	For bits which have been set to pulse output by NDERL_1, the output trigger transfers NDRL_1 values to this register during PPG operation. While NDERL_1 is set to 1, the CPU cannot write to this register. While NDERL_1 is cleared, the initial output value of the pulse can be set.
5	POD21	0	R/W	
4	POD20	0	R/W	
3	POD19	0	R/W	
2	POD18	0	R/W	
1	POD17	0	R/W	
0	POD16	0	R/W	

14.3.3 Next Data Registers H, L (NDRH, NDRL)

NDRH and NDRL store the next data for pulse output. The NDR addresses differ depending on whether pulse output groups have the same output trigger or different output triggers.

- NDRH

Bit	7	6	5	4	3	2	1	0
Bit Name	NDR15	NDR14	NDR13	NDR12	NDR11	NDR10	NDR9	NDR8
Initial Value	0	0	0	0	0	0	0	0
R/W	R/W	R/W	R/W	R/W	R/W	R/W	R/W	R/W

- NDRL

Bit	7	6	5	4	3	2	1	0
Bit Name	NDR7	NDR6	NDR5	NDR4	NDR3	NDR2	NDR1	NDR0
Initial Value	0	0	0	0	0	0	0	0
R/W	R/W	R/W	R/W	R/W	R/W	R/W	R/W	R/W

- NDRH

If pulse output groups 2 and 3 have the same output trigger, all eight bits are mapped to the same address and can be accessed at one time, as shown below.

Bit	Bit Name	Initial Value	R/W	Description
7	NDR15	0	R/W	Next Data Register 15 to 8
6	NDR14	0	R/W	The register contents are transferred to the corresponding PODRH bits by the output trigger specified with PCR.
5	NDR13	0	R/W	
4	NDR12	0	R/W	
3	NDR11	0	R/W	
2	NDR10	0	R/W	
1	NDR9	0	R/W	
0	NDR8	0	R/W	

If pulse output groups 2 and 3 have different output triggers, the upper four bits and lower four bits are mapped to different addresses as shown below.

Bit	Bit Name	Initial Value	R/W	Description
7	NDR15	0	R/W	Next Data Register 15 to 12
6	NDR14	0	R/W	The register contents are transferred to the corresponding PODRH bits by the output trigger specified with PCR.
5	NDR13	0	R/W	
4	NDR12	0	R/W	
3 to 0	—	All 1	—	Reserved These bits are always read as 1 and cannot be modified.

Bit	Bit Name	Initial Value	R/W	Description
7 to 4	—	All 1	—	Reserved These bits are always read as 1 and cannot be modified.
3	NDR11	0	R/W	Next Data Register 11 to 8
2	NDR10	0	R/W	The register contents are transferred to the corresponding PODRH bits by the output trigger specified with PCR.
1	NDR9	0	R/W	
0	NDR8	0	R/W	

- NDRL

If pulse output groups 0 and 1 have the same output trigger, all eight bits are mapped to the same address and can be accessed at one time, as shown below.

Bit	Bit Name	Initial Value	R/W	Description
7	NDR7	0	R/W	Next Data Register 7 to 0
6	NDR6	0	R/W	The register contents are transferred to the corresponding PODRL bits by the output trigger specified with PCR.
5	NDR5	0	R/W	
4	NDR4	0	R/W	
3	NDR3	0	R/W	
2	NDR2	0	R/W	
1	NDR1	0	R/W	
0	NDR0	0	R/W	

If pulse output groups 0 and 1 have different output triggers, the upper four bits and lower four bits are mapped to different addresses as shown below.

Bit	Bit Name	Initial Value	R/W	Description
7	NDR7	0	R/W	Next Data Register 7 to 4
6	NDR6	0	R/W	The register contents are transferred to the corresponding PODRL bits by the output trigger specified with PCR.
5	NDR5	0	R/W	
4	NDR4	0	R/W	
3 to 0	—	All 1	—	Reserved These bits are always read as 1 and cannot be modified.

Bit	Bit Name	Initial Value	R/W	Description
7 to 4	—	All 1	—	Reserved These bits are always read as 1 and cannot be modified.
3	NDR3	0	R/W	Next Data Register 3 to 0
2	NDR2	0	R/W	The register contents are transferred to the corresponding PODRL bits by the output trigger specified with PCR.
1	NDR1	0	R/W	
0	NDR0	0	R/W	

- NDRH_1

If pulse output groups 6 and 7 have the same output trigger, all eight bits are mapped to the same address and can be accessed at one time, as shown below.

Bit	Bit Name	Initial Value	R/W	Description
7	NDR31	0	R/W	Next Data Register 31 to 24
6	NDR30	0	R/W	The register contents are transferred to the corresponding PODRH_1 bits by the output trigger specified with PCR_1.
5	NDR29	0	R/W	
4	NDR28	0	R/W	
3	NDR27	0	R/W	
2	NDR26	0	R/W	
1	NDR25	0	R/W	
0	NDR24	0	R/W	

If pulse output groups 6 and 7 have different output triggers, the upper four bits and lower four bits are mapped to different addresses as shown below.

Bit	Bit Name	Initial Value	R/W	Description
7	NDR31	0	R/W	Next Data Register 31 to 28
6	NDR30	0	R/W	The register contents are transferred to the corresponding PODRH_1 bits by the output trigger specified with PCR_1.
5	NDR29	0	R/W	
4	NDR28	0	R/W	
3 to 0	—	All 1	—	

Bit	Bit Name	Initial Value	R/W	Description
7 to 4	—	All 1	—	Reserved These bits are always read as 1 and cannot be modified.
3	NDR27	0	R/W	Next Data Register 27 to 24
2	NDR26	0	R/W	The register contents are transferred to the corresponding PODRH_1 bits by the output trigger specified with PCR_1.
1	NDR25	0	R/W	
0	NDR24	0	R/W	

- NDRL_1

If pulse output groups 4 and 5 have the same output trigger, all eight bits are mapped to the same address and can be accessed at one time, as shown below.

Bit	Bit Name	Initial Value	R/W	Description
7	NDR23	0	R/W	Next Data Register 23 to 16
6	NDR22	0	R/W	The register contents are transferred to the corresponding PODRL_1 bits by the output trigger specified with PCR_1.
5	NDR21	0	R/W	
4	NDR20	0	R/W	
3	NDR19	0	R/W	
2	NDR18	0	R/W	
1	NDR17	0	R/W	
0	NDR16	0	R/W	

If pulse output groups 4 and 5 have different output triggers, the upper four bits and lower four bits are mapped to different addresses as shown below.

Bit	Bit Name	Initial Value	R/W	Description
7	NDR23	0	R/W	Next Data Register 23 to 20
6	NDR22	0	R/W	The register contents are transferred to the corresponding PODRL_1 bits by the output trigger specified with PCR_1.
5	NDR21	0	R/W	
4	NDR20	0	R/W	
3 to 0	—	All 1	—	Reserved These bits are always read as 1 and cannot be modified.

Bit	Bit Name	Initial Value	R/W	Description
7 to 4	—	All 1	—	Reserved These bits are always read as 1 and cannot be modified.
3	NDR19	0	R/W	Next Data Register 19 to 16
2	NDR18	0	R/W	The register contents are transferred to the corresponding PODRL_1 bits by the output trigger specified with PCR_1.
1	NDR17	0	R/W	
0	NDR16	0	R/W	

14.3.4 PPG Output Control Register (PCR)

PCR selects output trigger signals on a group-by-group basis. For details on output trigger selection, refer to section 14.3.5, PPG Output Mode Register (PMR).

Bit	7	6	5	4	3	2	1	0
Bit Name	G3CMS1	G3CMS0	G2CMS1	G2CMS0	G1CMS1	G1CMS0	G0CMS1	G0CMS0
Initial Value	1	1	1	1	1	1	1	1
R/W	R/W	R/W	R/W	R/W	R/W	R/W	R/W	R/W

Bit	Bit Name	Initial Value	R/W	Description
7	G3CMS1	1	R/W	Group 3 Compare Match Select 1 and 0
6	G3CMS0	1	R/W	These bits select output trigger of pulse output group 3. 00: Compare match in TPU channel 0 01: Compare match in TPU channel 1 10: Compare match in TPU channel 2 11: Compare match in TPU channel 3
5	G2CMS1	1	R/W	Group 2 Compare Match Select 1 and 0
4	G2CMS0	1	R/W	These bits select output trigger of pulse output group 2. 00: Compare match in TPU channel 0 01: Compare match in TPU channel 1 10: Compare match in TPU channel 2 11: Compare match in TPU channel 3
3	G1CMS1	1	R/W	Group 1 Compare Match Select 1 and 0
2	G1CMS0	1	R/W	These bits select output trigger of pulse output group 1. 00: Compare match in TPU channel 0 01: Compare match in TPU channel 1 10: Compare match in TPU channel 2 11: Compare match in TPU channel 3
1	G0CMS1	1	R/W	Group 0 Compare Match Select 1 and 0
0	G0CMS0	1	R/W	These bits select output trigger of pulse output group 0. 00: Compare match in TPU channel 0 01: Compare match in TPU channel 1 10: Compare match in TPU channel 2 11: Compare match in TPU channel 3

- PCR_1

Bit	Bit Name	Initial Value	R/W	Description
7	G3CMS1	1	R/W	Group 7 Compare Match Select 1 and 0
6	G3CMS0	1	R/W	These bits select output trigger of pulse output group 7. 00: Compare match in TPU channel 6 01: Compare match in TPU channel 7 10: Compare match in TPU channel 8 11: Compare match in TPU channel 9
5	G2CMS1	1	R/W	Group 6 Compare Match Select 1 and 0
4	G2CMS0	1	R/W	These bits select output trigger of pulse output group 6. 00: Compare match in TPU channel 6 01: Compare match in TPU channel 7 10: Compare match in TPU channel 8 11: Compare match in TPU channel 9
3	G1CMS1	1	R/W	Group 5 Compare Match Select 1 and 0
2	G1CMS0	1	R/W	These bits select output trigger of pulse output group 5. 00: Compare match in TPU channel 6 01: Compare match in TPU channel 7 10: Compare match in TPU channel 8 11: Compare match in TPU channel 9
1	G0CMS1	1	R/W	Group 4 Compare Match Select 1 and 0
0	G0CMS0	1	R/W	These bits select output trigger of pulse output group 4. 00: Compare match in TPU channel 6 01: Compare match in TPU channel 7 10: Compare match in TPU channel 8 11: Compare match in TPU channel 9

14.3.5 PPG Output Mode Register (PMR)

PMR selects the pulse output mode of the PPG for each group. If inverted output is selected, a low-level pulse is output when PODRH is 1 and a high-level pulse is output when PODRH is 0. If non-overlapping operation is selected, PPG updates its output values at compare match A or B of the TPU that becomes the output trigger. For details, refer to section 14.4.4, Non-Overlapping Pulse Output.

Bit	7	6	5	4	3	2	1	0
Bit Name	G3INV	G2INV	G1INV	G0INV	G3NOV	G2NOV	G1NOV	G0NOV
Initial Value	1	1	1	1	0	0	0	0
R/W	R/W	R/W	R/W	R/W	R/W	R/W	R/W	R/W

Bit	Bit Name	Initial Value	R/W	Description
7	G3INV	1	R/W	Group 3 Inversion Selects direct output or inverted output for pulse output group 3. 0: Inverted output 1: Direct output
6	G2INV	1	R/W	Group 2 Inversion Selects direct output or inverted output for pulse output group 2. 0: Inverted output 1: Direct output
5	G1INV	1	R/W	Group 1 Inversion Selects direct output or inverted output for pulse output group 1. 0: Inverted output 1: Direct output
4	G0INV	1	R/W	Group 0 Inversion Selects direct output or inverted output for pulse output group 0. 0: Inverted output 1: Direct output

Bit	Bit Name	Initial Value	R/W	Description
3	G3NOV	0	R/W	<p>Group 3 Non-Overlap</p> <p>Selects normal or non-overlapping operation for pulse output group 3.</p> <p>0: Normal operation (output values updated at compare match A in the selected TPU channel)</p> <p>1: Non-overlapping operation (output values updated at compare match A or B in the selected TPU channel)</p>
2	G2NOV	0	R/W	<p>Group 2 Non-Overlap</p> <p>Selects normal or non-overlapping operation for pulse output group 2.</p> <p>0: Normal operation (output values updated at compare match A in the selected TPU channel)</p> <p>1: Non-overlapping operation (output values updated at compare match A or B in the selected TPU channel)</p>
1	G1NOV	0	R/W	<p>Group 1 Non-Overlap</p> <p>Selects normal or non-overlapping operation for pulse output group 1.</p> <p>0: Normal operation (output values updated at compare match A in the selected TPU channel)</p> <p>1: Non-overlapping operation (output values updated at compare match A or B in the selected TPU channel)</p>
0	G0NOV	0	R/W	<p>Group 0 Non-Overlap</p> <p>Selects normal or non-overlapping operation for pulse output group 0.</p> <p>0: Normal operation (output values updated at compare match A in the selected TPU channel)</p> <p>1: Non-overlapping operation (output values updated at compare match A or B in the selected TPU channel)</p>

- PMR_1

Bit	Bit Name	Initial Value	R/W	Description
7	G3INV	1	R/W	Group 7 Inversion Selects direct output or inverted output for pulse output group 7. 0: Inverted output 1: Direct output
6	G2INV	1	R/W	Group 6 Inversion Selects direct output or inverted output for pulse output group 6. 0: Inverted output 1: Direct output
5	G1INV	1	R/W	Group 5 Inversion Selects direct output or inverted output for pulse output group 5. 0: Inverted output 1: Direct output
4	G0INV	1	R/W	Group 4 Inversion Selects direct output or inverted output for pulse output group 4. 0: Inverted output 1: Direct output

Bit	Bit Name	Initial Value	R/W	Description
3	G3NOV	0	R/W	<p>Group 7 Non-Overlap</p> <p>Selects normal or non-overlapping operation for pulse output group 7.</p> <p>0: Normal operation (output values updated by compare match A on the selected TPU channel)</p> <p>1: Non-overlapping operation (output values updated by compare match A or B on the selected TPU channel)</p>
2	G2NOV	0	R/W	<p>Group 6 Non-Overlap</p> <p>Selects normal or non-overlapping operation for pulse output group 6.</p> <p>0: Normal operation (output values updated by compare match A on the selected TPU channel)</p> <p>1: Non-overlapping operation (output values updated by compare match A or B on the selected TPU channel)</p>
1	G1NOV	0	R/W	<p>Group 5 Non-Overlap</p> <p>Selects normal or non-overlapping operation for pulse output group 5.</p> <p>0: Normal operation (output values updated by compare match A on the selected TPU channel)</p> <p>1: Non-overlapping operation (output values updated by compare match A or B on the selected TPU channel)</p>
0	G0NOV	0	R/W	<p>Group 4 Non-Overlap</p> <p>Selects normal or non-overlapping operation for pulse output group 4.</p> <p>0: Normal operation (output values updated by compare match A on the selected TPU channel)</p> <p>1: Non-overlapping operation (output values updated by compare match A or B on the selected TPU channel)</p>

14.4 Operation

Figure 14.3 shows a schematic diagram of the PPG. PPG pulse output is enabled when the corresponding bits in NDER are set to 1. An initial output value is determined by its corresponding PODR initial setting. When the compare match event specified by PCR occurs, the corresponding NDR bit contents are transferred to PODR to update the output values. Sequential output of data of up to 16 bits is possible by writing new output data to NDR before the next compare match.

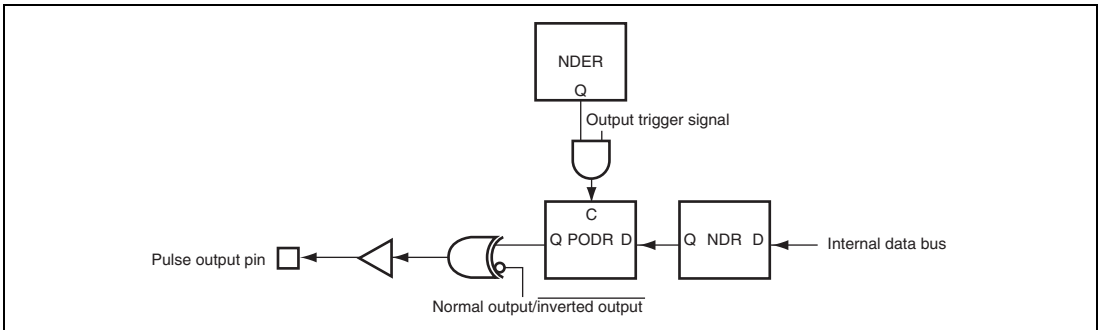

Figure 14.3 Schematic Diagram of PPG

14.4.1 Output Timing

If pulse output is enabled, the NDR contents are transferred to PODR and output when the specified compare match event occurs. Figure 14.4 shows the timing of these operations for the case of normal output in groups 2 and 3, triggered by compare match A.

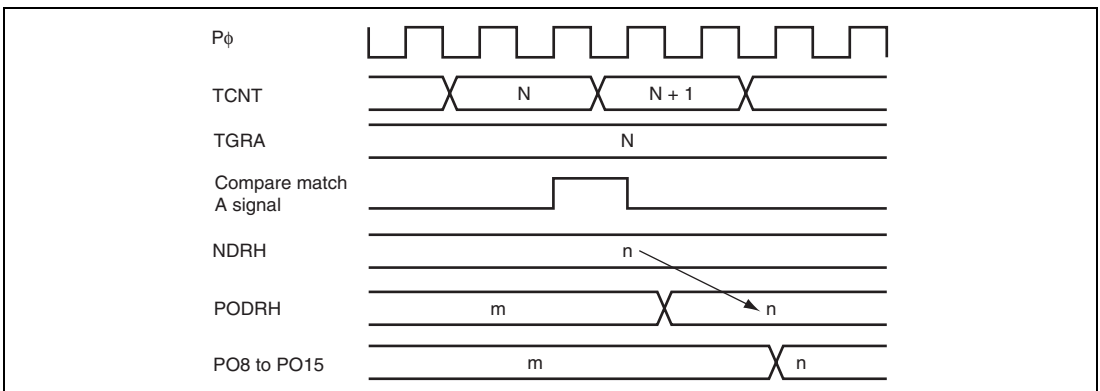

Figure 14.4 Timing of Transfer and Output of NDR Contents (Example)

14.4.2 Sample Setup Procedure for Normal Pulse Output

Figures 14.5 and 14.6 show a sample procedure for setting up normal pulse output.

- Sample Setup Procedure for PPG0

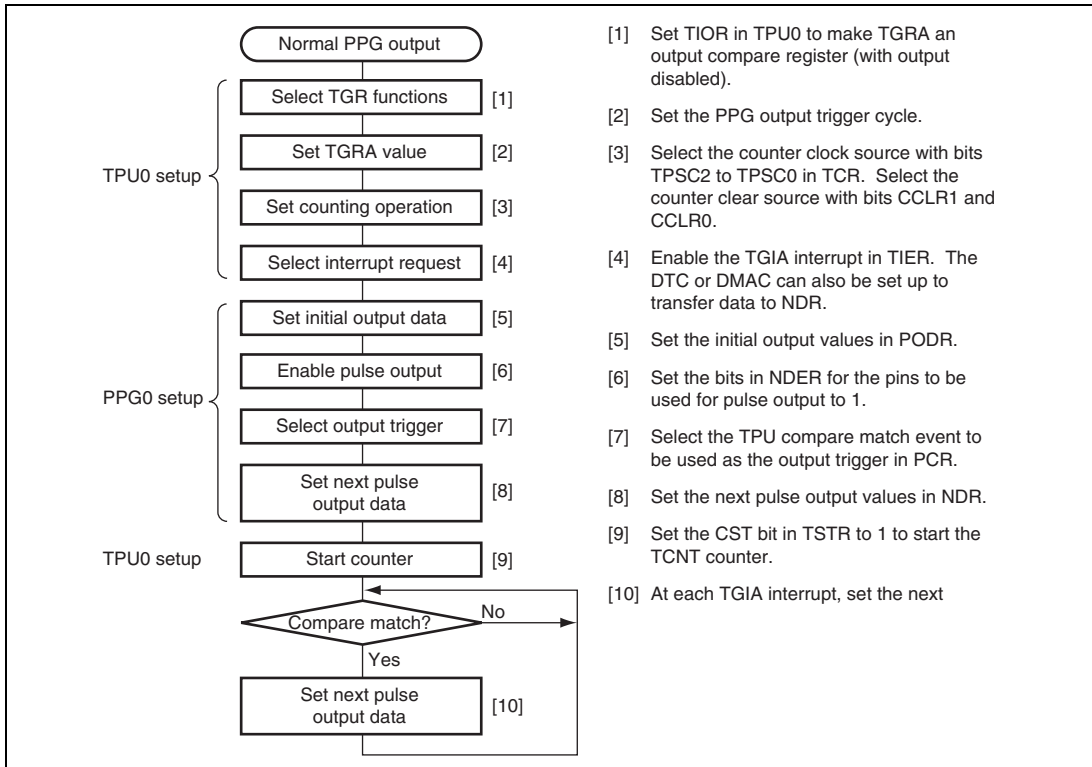

Figure 14.5 Setup Procedure for Normal Pulse Output (PPG0)

- Sample Setup Procedure for PPG1

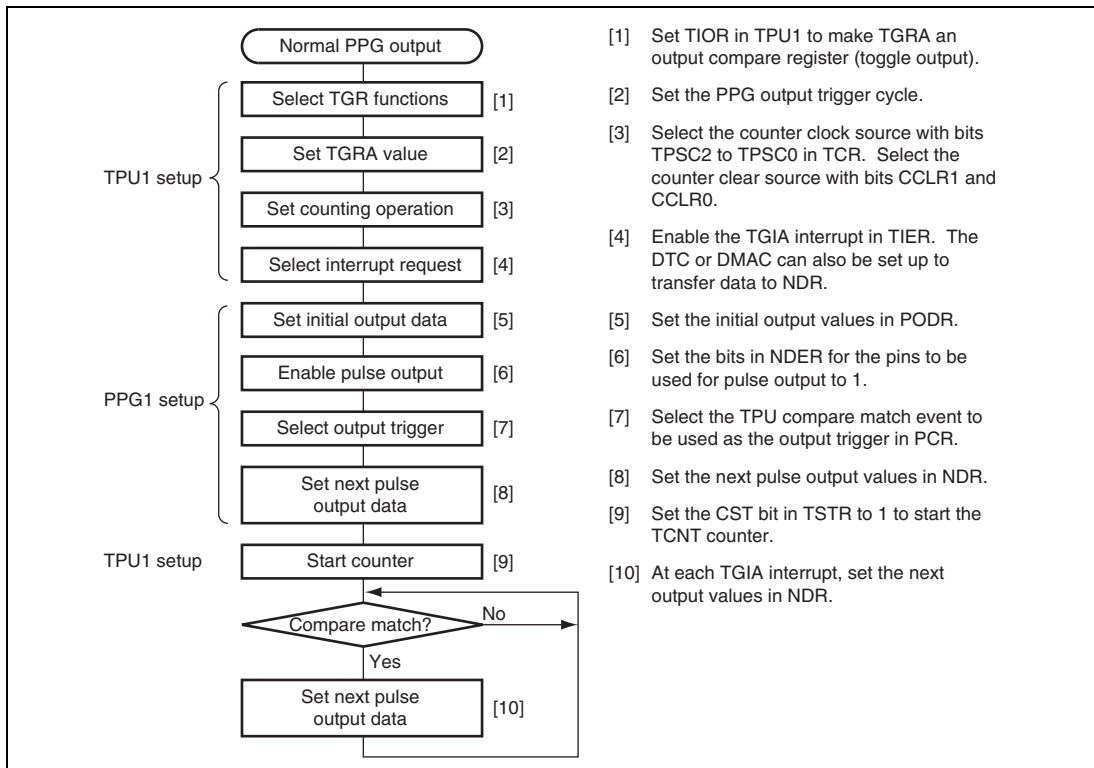

Figure 14.6 Setup Procedure for Normal Pulse Output (PPG1)

14.4.3 Example of Normal Pulse Output (Example of 5-Phase Pulse Output)

Figure 14.7 shows an example in which pulse output is used for cyclic 5-phase pulse output.

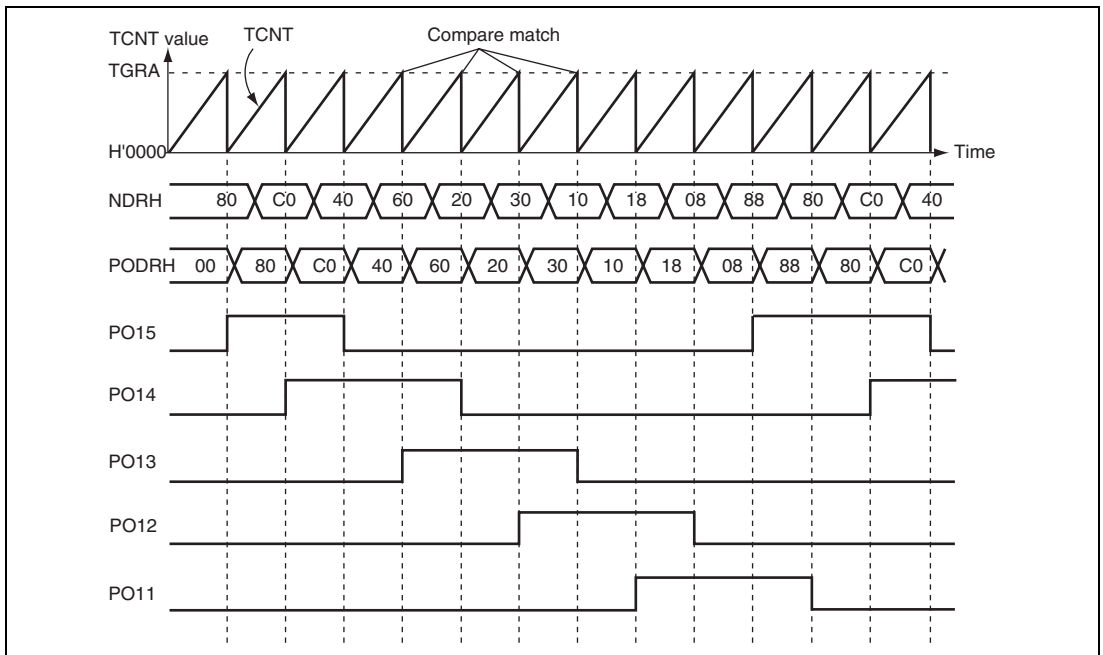

Figure 14.7 Normal Pulse Output Example (5-Phase Pulse Output)

1. Set up TGRA in TPU which is used as the output trigger to be an output compare register. Set a cycle in TGRA so the counter will be cleared by compare match A. Set the TGIEA bit in TIER to 1 to enable the compare match/input capture A (TGIA) interrupt.
2. Write H'F8 to NDERH, and set bits G3CMS1, G3CMS0, G2CMS1, and G2CMS0 in PCR to select compare match in the TPU channel set up in the previous step to be the output trigger. Write output data H'80 in NDRH.
3. The timer counter in the TPU channel starts. When compare match A occurs, the NDRH contents are transferred to PODRH and output. The TGIA interrupt handling routine writes the next output data (H'C0) in NDRH.
4. 5-phase pulse output (one or two phases active at a time) can be obtained subsequently by writing H'40, H'60, H'20, H'30, H'10, H'18, H'08, H'88... at successive TGIA interrupts. If the DTC or DMAC is set for activation by the TGIA interrupt, pulse output can be obtained without imposing a load on the CPU.

14.4.4 Non-Overlapping Pulse Output

During non-overlapping operation, transfer from NDR to PODR is performed as follows:

- At compare match A, the NDR bits are always transferred to PODR.
- At compare match B, the NDR bits are transferred only if their value is 0. The NDR bits are not transferred if their value is 1.

Figure 14.8 illustrates the non-overlapping pulse output operation.

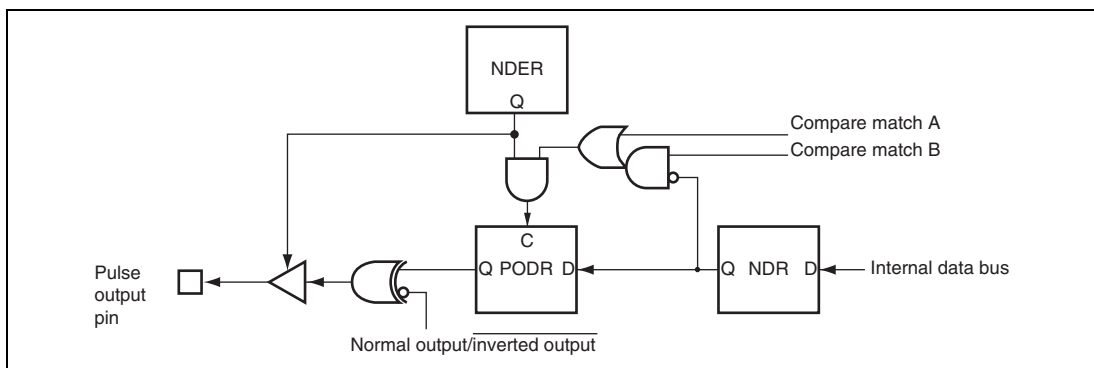

Figure 14.8 Non-Overlapping Pulse Output

Therefore, 0 data can be transferred ahead of 1 data by making compare match B occur before compare match A.

The NDR contents should not be altered during the interval from compare match B to compare match A (the non-overlapping margin).

This can be accomplished by having the TGIA interrupt handling routine write the next data in NDR, or by having the TGIA interrupt activate the DTC or DMAC. Note, however, that the next data must be written before the next compare match B occurs.

Figure 14.9 shows the timing of this operation.

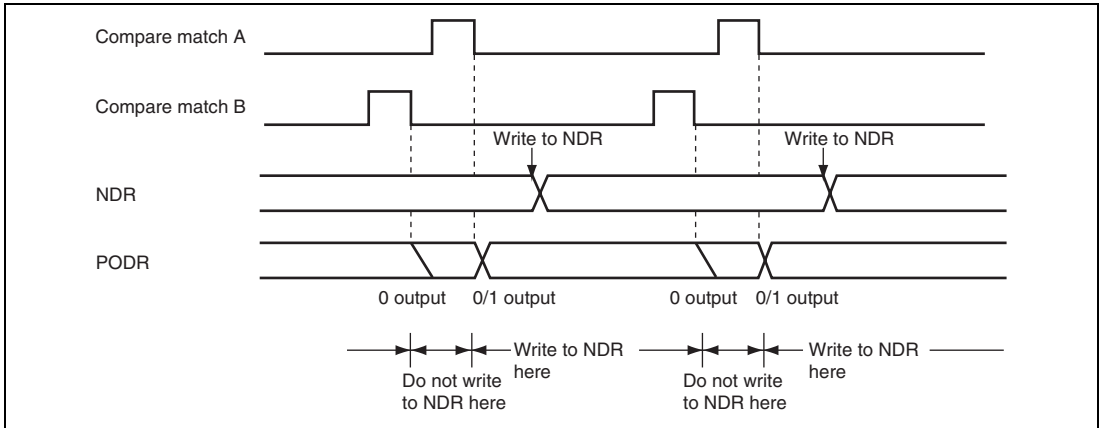

Figure 14.9 Non-Overlapping Operation and NDR Write Timing

14.4.5 Sample Setup Procedure for Non-Overlapping Pulse Output

Figures 14.10 and 14.11 show a sample procedure for setting up non-overlapping pulse output.

- Sample Setup Procedure for PPG0

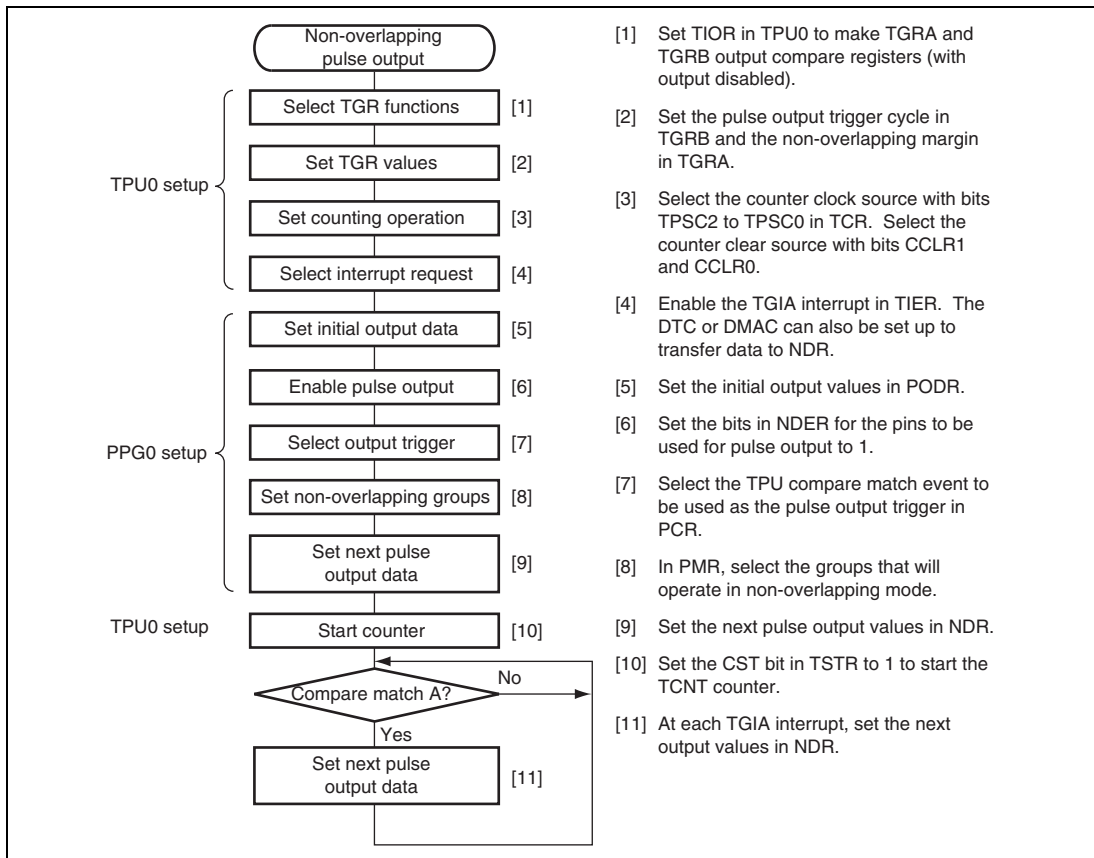

Figure 14.10 Setup Procedure for Non-Overlapping Pulse Output (PPG0)

- Sample Setup Procedure for PPG1

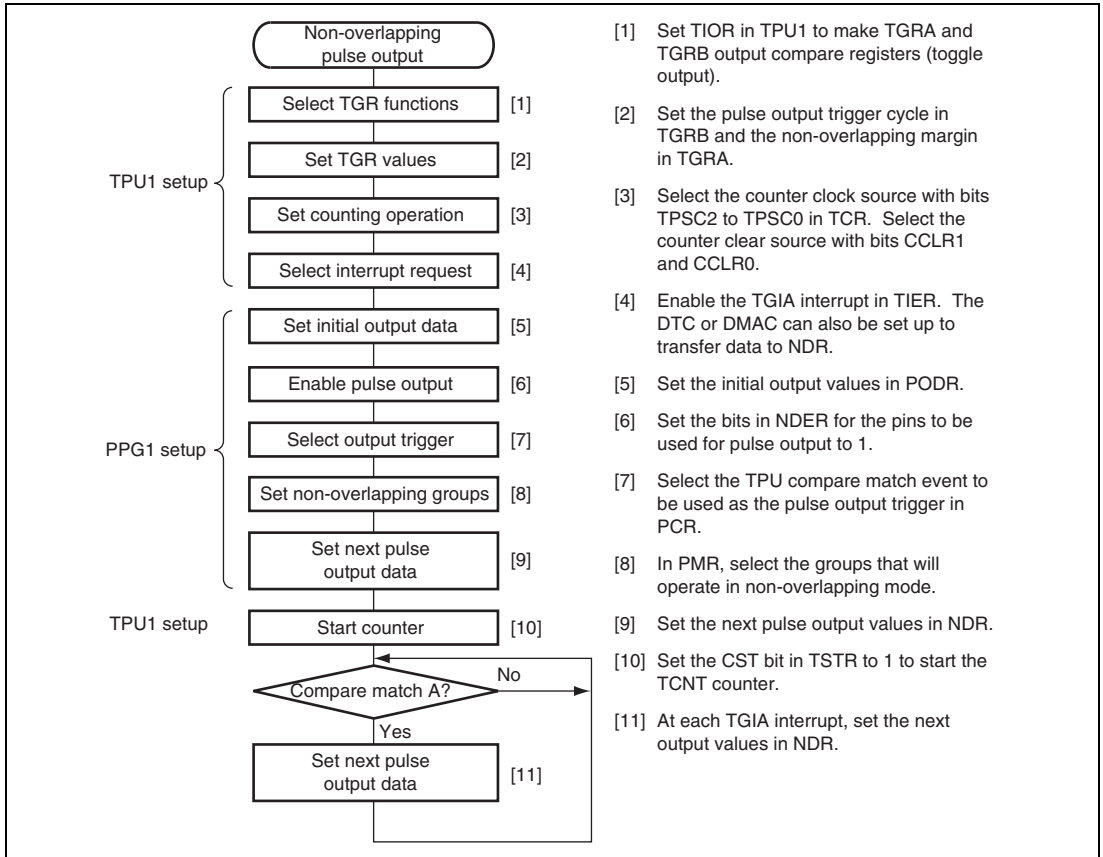

Figure 14.11 Setup Procedure for Non-Overlapping Pulse Output (PPG1)

14.4.6 Example of Non-Overlapping Pulse Output (Example of 4-Phase Complementary Non-Overlapping Pulse Output)

Figure 14.12 shows an example in which pulse output is used for 4-phase complementary non-overlapping pulse output.

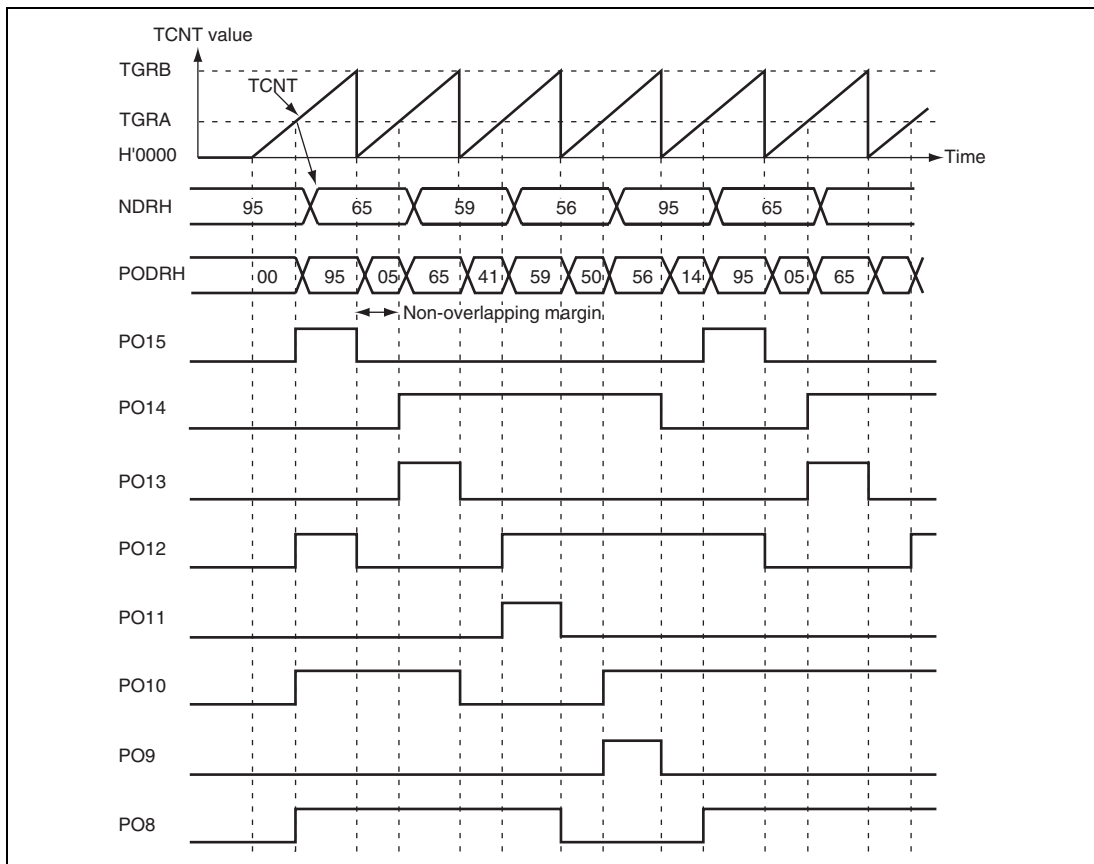

Figure 14.12 Non-Overlapping Pulse Output Example (4-Phase Complementary)

1. Set up the TPU channel to be used as the output trigger channel so that TGRA and TGRB are output compare registers. Set the cycle in TGRB and the non-overlapping margin in TGRA, and set the counter to be cleared by compare match B. Set the TGIEA bit in TIER to 1 to enable the TGIA interrupt.
2. Write H'FF to NDERH, and set bits G3CMS1, G3CMS0, G2CMS1, and G2CMS0 in PCR to select compare match in the TPU channel set up in the previous step to be the output trigger. Set bits G3NOV and G2NOV in PMR to 1 to select non-overlapping pulse output. Write output data H'95 to NDRH.
3. The timer counter in the TPU channel starts. When a compare match with TGRB occurs, outputs change from 1 to 0. When a compare match with TGRA occurs, outputs change from 0 to 1 (the change from 0 to 1 is delayed by the value set in TGRA).
The TGIA interrupt handling routine writes the next output data (H'65) to NDRH.
4. 4-phase complementary non-overlapping pulse output can be obtained subsequently by writing H'59, H'56, H'95... at successive TGIA interrupts.
If the DTC or DMAC is set for activation by a TGIA interrupt, pulse can be output without imposing a load on the CPU.

14.4.7 Inverted Pulse Output

If the G3INV, G2INV, G1INV, and G0INV bits in PMR are cleared to 0, values that are the inverse of the PODR contents can be output.

Figure 14.13 shows the outputs when the G3INV and G2INV bits are cleared to 0, in addition to the settings of Figure 14.12.

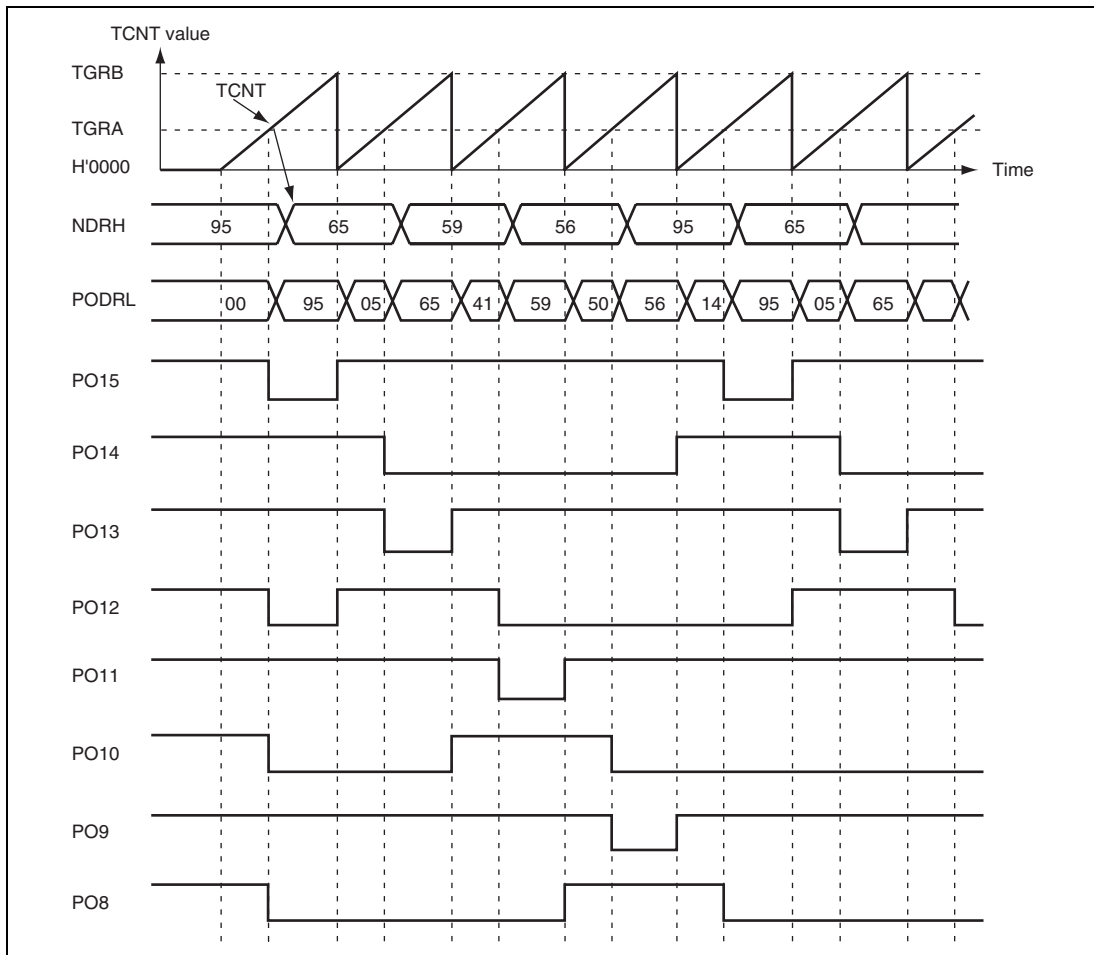

Figure 14.13 Inverted Pulse Output (Example)

14.4.8 Pulse Output Triggered by Input Capture

Pulse output of PPG0 can be triggered by TPU0 input capture as well as by compare match. If TGRA functions as an input capture register in the TPU0 channel selected by PCR, pulse output will be triggered by the input capture signal.

Figure 14.14 shows the timing of this output.

PPG1 cannot be used to trigger pulse output by input capturer.

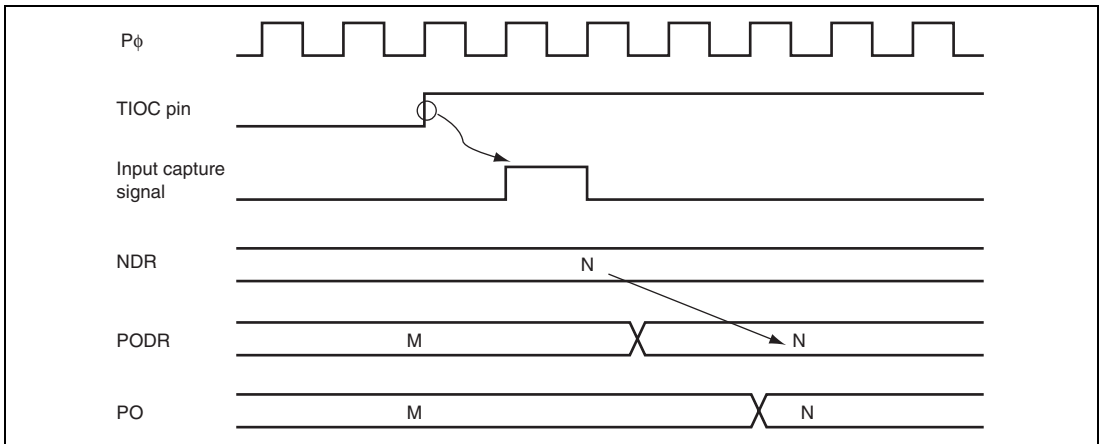

Figure 14.14 Pulse Output Triggered by Input Capture (Example)

14.5 Usage Notes

14.5.1 Module Stop State Setting

PPG operation can be disabled or enabled using the module stop control register. The initial value is for PPG operation to be halted. Register access is enabled by clearing the module stop state. For details, refer to section 25, Power-Down Modes.

14.5.2 Operation of Pulse Output Pins

Pins PO0 to PO15 are also used for other peripheral functions such as the TPU. When output by another peripheral function is enabled, the corresponding pins cannot be used for pulse output. Note, however, that data transfer from NDR bits to PODR bits takes place, regardless of the usage of the pins.

Pin functions should be changed only under conditions in which the output trigger event will not occur.

14.5.3 TPU Setting when PPG1 is in Use

When using PPG1, output toggling on compare-matches must be specified in the TIOR register of the TPU that acts as the activation source and output must be selected as the PPG1 function.

Section 15 8-Bit Timers (TMR)

This LSI has four units (unit 0 to unit 3) of an on-chip 8-bit timer module that comprise two 8-bit counter channels, totaling eight channels. The 8-bit timer module can be used to count external events and also be used as a multifunction timer in a variety of applications, such as generation of counter reset, interrupt requests, and pulse output with a desired duty cycle using a compare-match signal with two registers.

Figures 15.1 to 15.4 show block diagrams of the 8-bit timer module (unit 0 to unit 3).

This section describes unit 0 (channels 0 and 1) and unit 2 (channels 4 and 5), both of which have the same functions. Unit 2 and unit 3 can generate baud rate clock for SCI and have the same functions.

15.1 Features

- Selection of seven clock sources
The counters can be driven by one of six internal clock signals (P ϕ /2, P ϕ /8, P ϕ /32, P ϕ /64, P ϕ /1024, or P ϕ /8192) or an external clock input (only internal clock available in units 2 and 3: P ϕ , P ϕ /2, P ϕ /8, P ϕ /32, P ϕ /64, P ϕ /1024, and P ϕ /8192).
- Selection of three ways to clear the counters
The counters can be cleared on compare match A or B, or by an external reset signal. (This is available only in unit 0 and unit 1.)
- Timer output control by a combination of two compare match signals
The timer output signal in each channel is controlled by a combination of two independent compare match signals, enabling the timer to output pulses with a desired duty cycle or PWM output.
- Cascading of two channels
Operation as a 16-bit timer is possible, using TMR_0 for the upper 8 bits and TMR_1 for the lower 8 bits (16-bit count mode).
TMR_1 can be used to count TMR_0 compare matches (compare match count mode).
- Three interrupt sources
Compare match A, compare match B, and overflow interrupts can be requested independently. (This is available only in unit 0 and unit 1.)
- Generation of trigger to start A/D converter conversion (available in unit 0 and unit 1 only)
- Capable of generating baud rate clock for SCI_5 and SCI_6. (This is available only in unit 2 and unit 3). For details, see section 17, Serial Communication Interface (SCI, IrDA, CRC).
- Module stop state specifiable

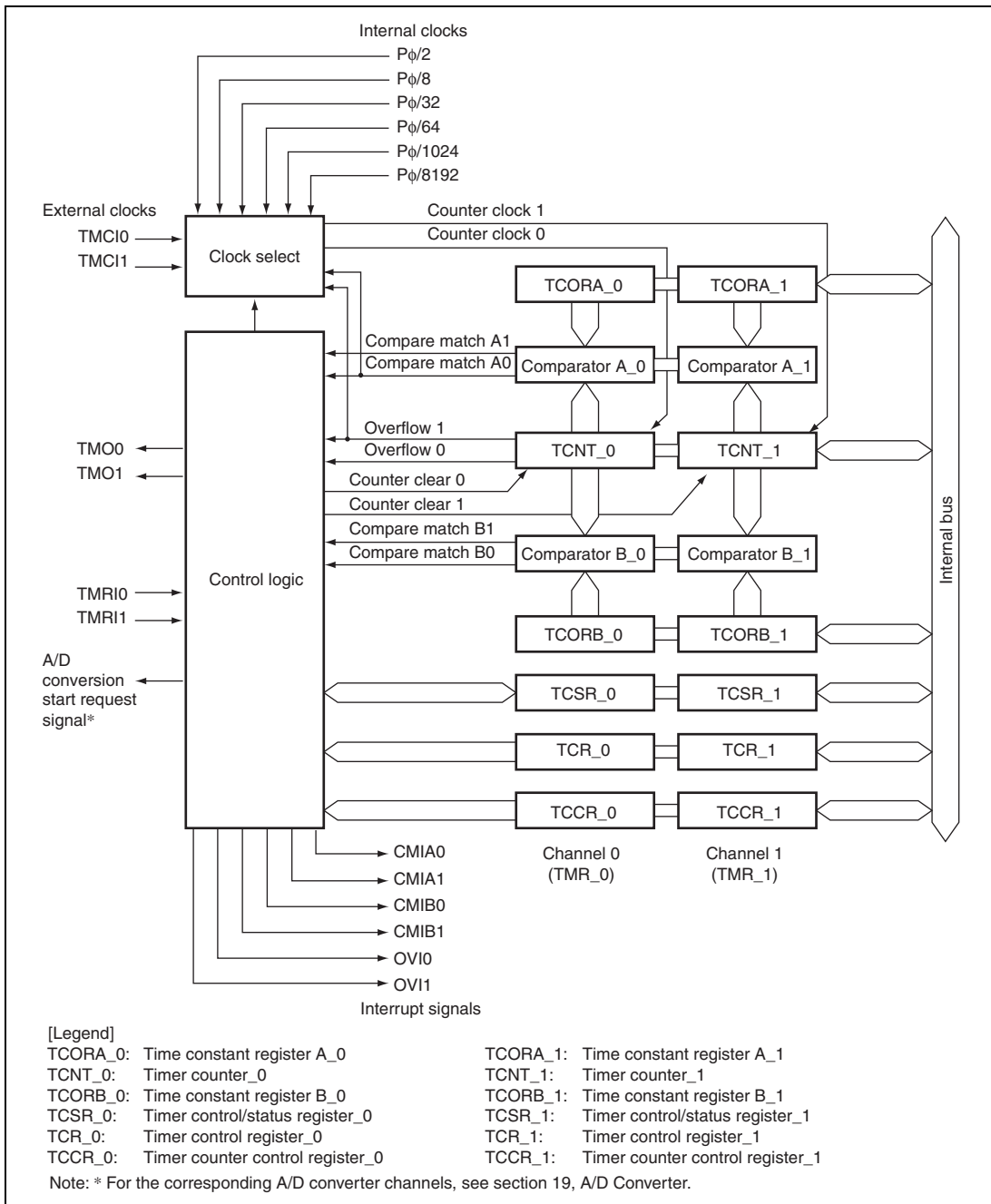

Figure 15.1 Block Diagram of 8-Bit Timer Module (Unit 0)

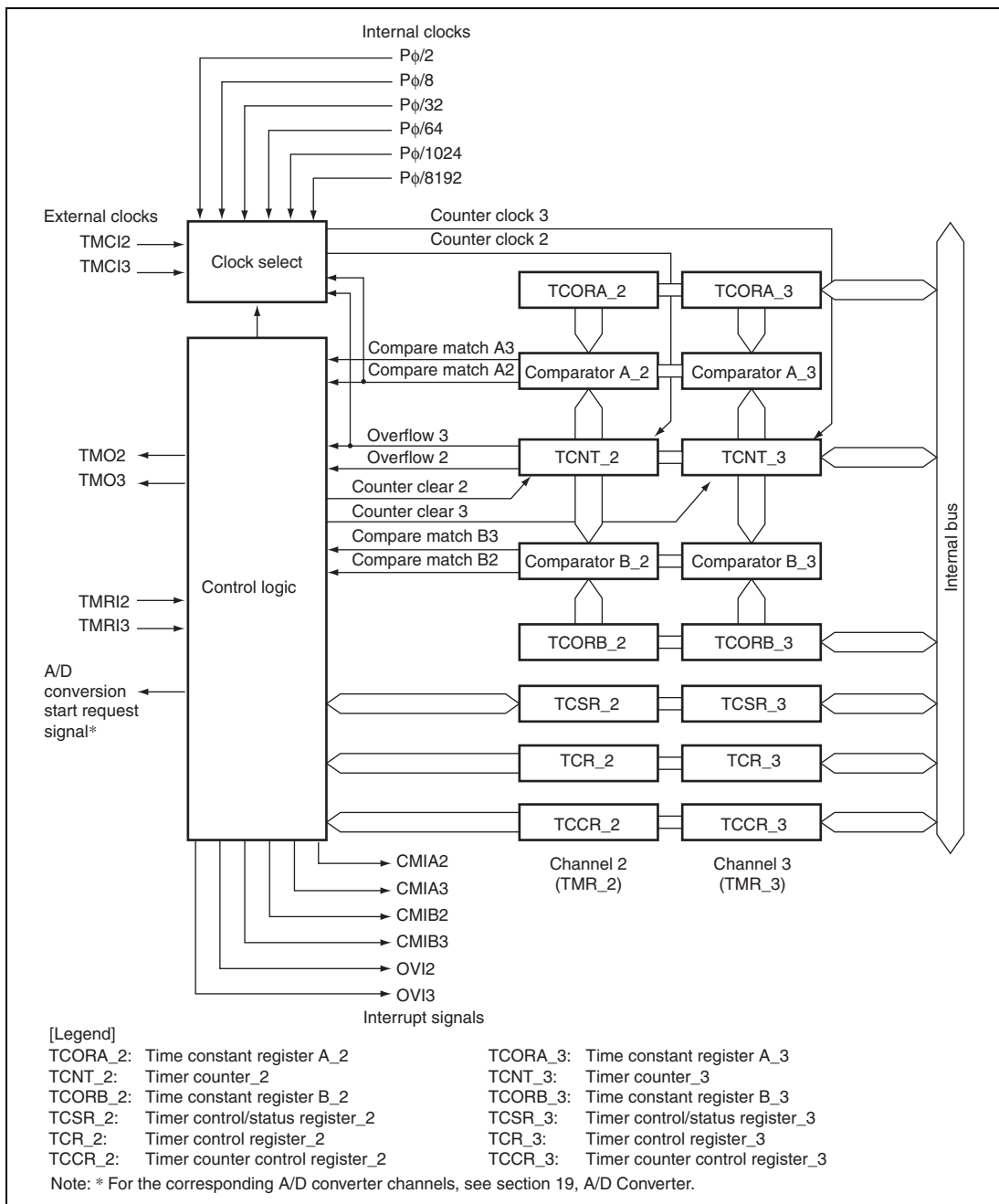

Figure 15.2 Block Diagram of 8-Bit Timer Module (Unit 1)

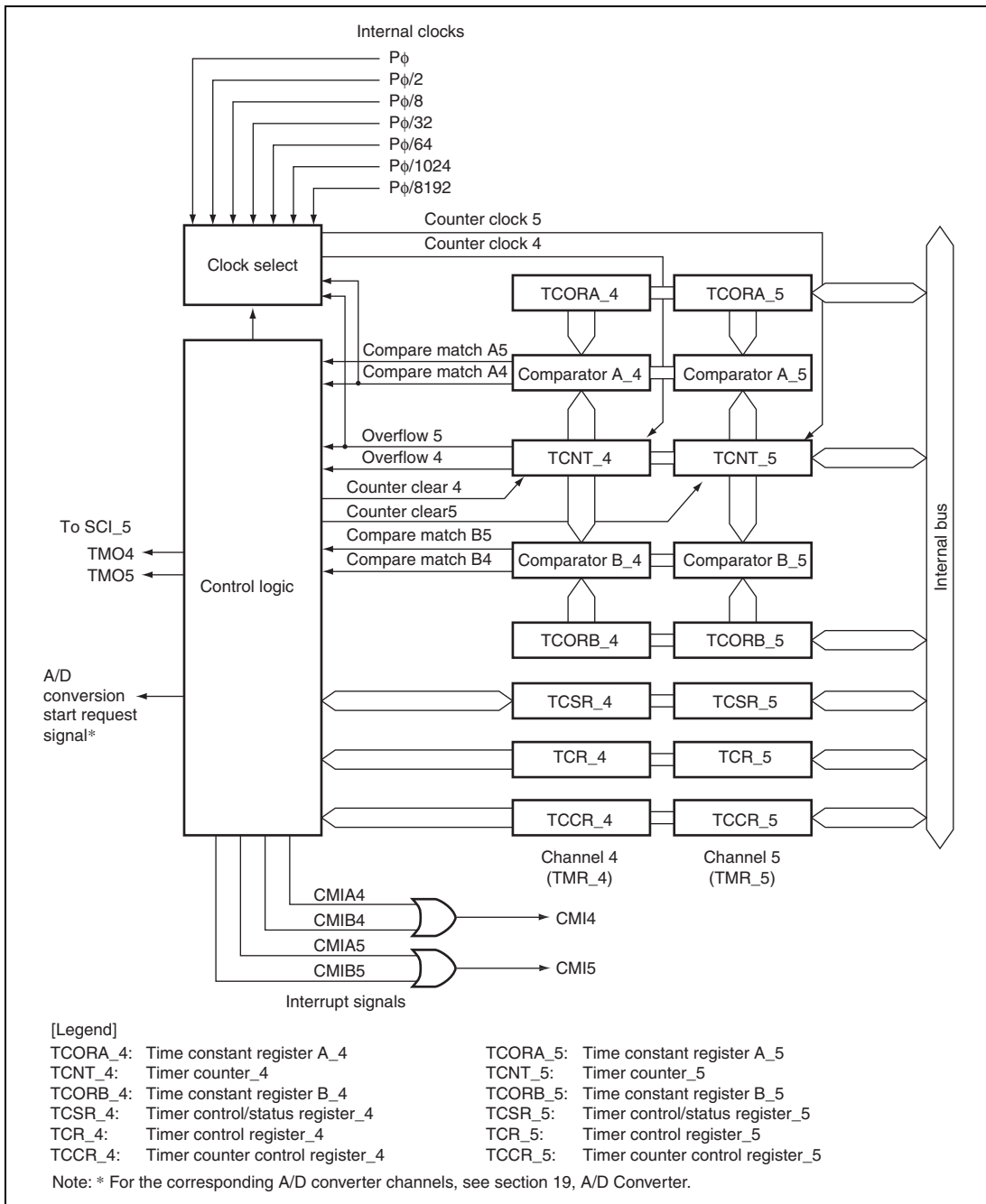

Figure 15.3 Block Diagram of 8-Bit Timer Module (Unit 2)

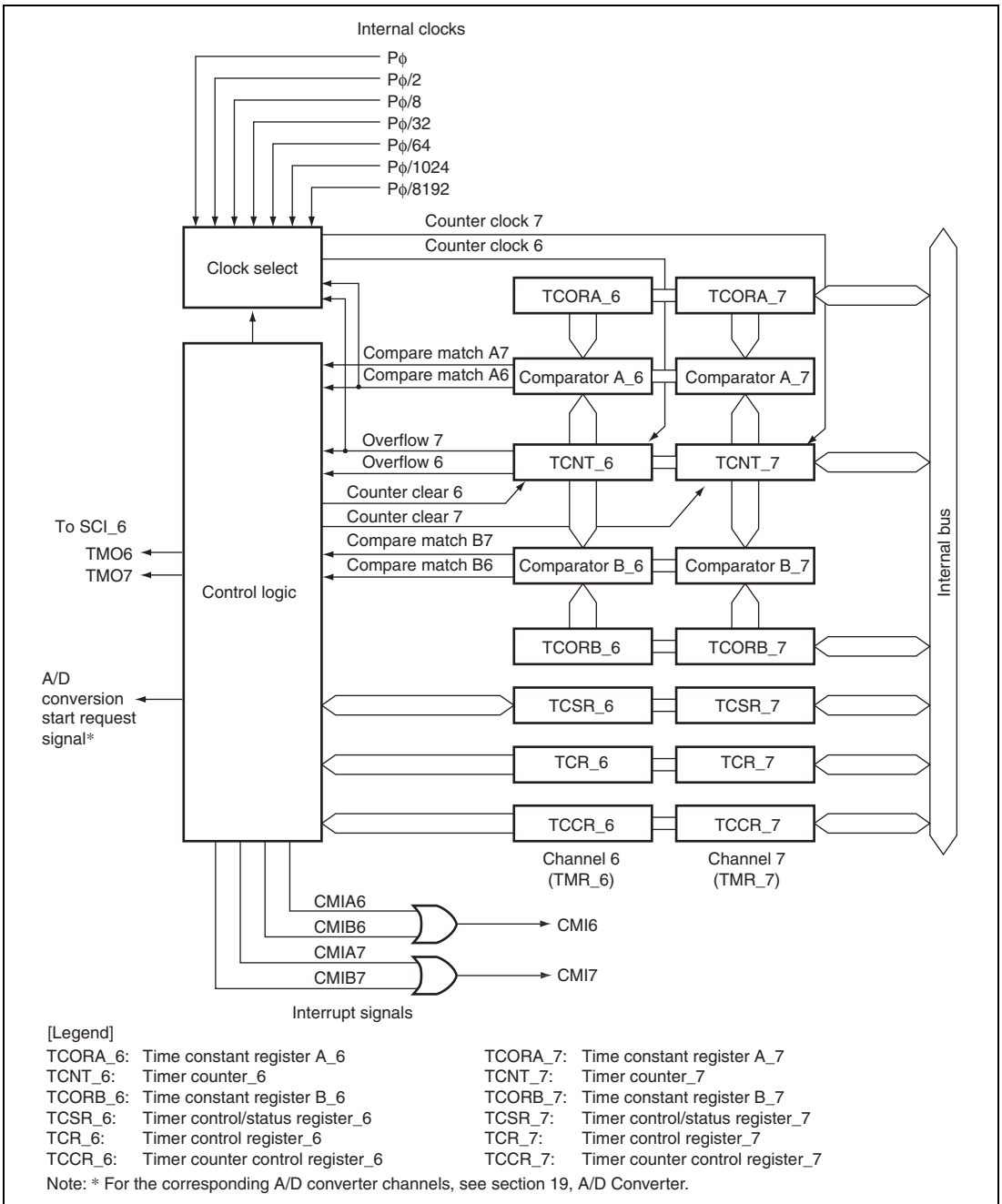

Figure 15.4 Block Diagram of 8-Bit Timer Module (Unit 3)

15.2 Input/Output Pins

Table 15.1 shows the pin configuration of the TMR.

Table 15.1 Pin Configuration

Unit	Channel	Name	Symbol	I/O	Function
0	0	Timer output pin	TMO0	Output	Outputs compare match
		Timer clock input pin	TMC10	Input	Inputs external clock for counter
		Timer reset input pin	TMRI0	Input	Inputs external reset to counter
	1	Timer output pin	TMO1	Output	Outputs compare match
		Timer clock input pin	TMC11	Input	Inputs external clock for counter
		Timer reset input pin	TMRI1	Input	Inputs external reset to counter
1	2	Timer output pin	TMO2	Output	Outputs compare match
		Timer clock input pin	TMC12	Input	Inputs external clock for counter
		Timer reset input pin	TMRI2	Input	Inputs external reset to counter
	3	Timer output pin	TMO3	Output	Outputs compare match
		Timer clock input pin	TMC13	Input	Inputs external clock for counter
		Timer reset input pin	TMRI3	Input	Inputs external reset to counter
2	4	—	—	—	—
	5	—	—	—	—
3	6	—	—	—	—
	7	—	—	—	—

15.3 Register Descriptions

The TMR has the following registers.

Unit 0:

- Channel 0 (TMR_0):
 - Timer counter_0 (TCNT_0)
 - Time constant register A_0 (TCORA_0)
 - Time constant register B_0 (TCORB_0)
 - Timer control register_0 (TCR_0)
 - Timer counter control register_0 (TCCR_0)
 - Timer control/status register_0 (TCSR_0)
- Channel 1 (TMR_1):
 - Timer counter_1 (TCNT_1)
 - Time constant register A_1 (TCORA_1)
 - Time constant register B_1 (TCORB_1)
 - Timer control register_1 (TCR_1)
 - Timer counter control register_1 (TCCR_1)
 - Timer control/status register_1 (TCSR_1)

Unit 1:

- Channel 2 (TMR_2):
 - Timer counter_2 (TCNT_2)
 - Time constant register A_2 (TCORA_2)
 - Time constant register B_2 (TCORB_2)
 - Timer control register_2 (TCR_2)
 - Timer counter control register_2 (TCCR_2)
 - Timer control/status register_2 (TCSR_2)
- Channel 3 (TMR_3):
 - Timer counter_3 (TCNT_3)
 - Time constant register A_3 (TCORA_3)
 - Time constant register B_3 (TCORB_3)
 - Timer control register_3 (TCR_3)
 - Timer counter control register_3 (TCCR_3)
 - Timer control/status register_3 (TCSR_3)

Unit 2:

- Channel 4 (TMR_4):
 - Timer counter_4 (TCNT_4)
 - Time constant register A_4 (TCORA_4)
 - Time constant register B_4 (TCORB_4)
 - Timer control register_4 (TCR_4)
 - Timer counter control register_4 (TCCR_4)
 - Timer control/status register_4 (TCSR_4)
- Channel 5 (TMR_5):
 - Timer counter_5 (TCNT_5)
 - Time constant register A_5 (TCORA_5)
 - Time constant register B_5 (TCORB_5)
 - Timer control register_5 (TCR_5)
 - Timer counter control register_5 (TCCR_5)
 - Timer control/status register_5 (TCSR_5)

Unit 3:

- Channel 6 (TMR_6):
 - Timer counter_6 (TCNT_6)
 - Time constant register A_6 (TCORA_6)
 - Time constant register B_6 (TCORB_6)
 - Timer control register_6 (TCR_6)
 - Timer counter control register_6 (TCCR_6)
 - Timer control/status register_6 (TCSR_6)
- Channel 7 (TMR_7):
 - Timer counter_7 (TCNT_7)
 - Time constant register A_7 (TCORA_7)
 - Time constant register B_7 (TCORB_7)
 - Timer control register_7 (TCR_7)
 - Timer counter control register_7 (TCCR_7)
 - Timer control/status register_7 (TCSR_7)

15.3.1 Timer Counter (TCNT)

TCNT is an 8-bit readable/writable up-counter. TCNT_0 and TCNT_1 comprise a single 16-bit register so they can be accessed together by a word transfer instruction. Bits CKS2 to CKS0 in TCR and bits ICKS1 and ICKS0 in TCCR are used to select a clock. TCNT can be cleared by an external reset input signal, compare match A signal, or compare match B signal. Which signal to be used for clearing is selected by bits CCLR1 and CCLR0 in TCR. When TCNT overflows from H'FF to H'00, bit OVF in TCSR is set to 1. TCNT is initialized to H'00.

Bit	TCNT_0								TCNT_1							
Bit Name	7	6	5	4	3	2	1	0	7	6	5	4	3	2	1	0
Initial Value	0	0	0	0	0	0	0	0	0	0	0	0	0	0	0	0
R/W	R/W	R/W	R/W	R/W	R/W	R/W	R/W	R/W	R/W	R/W	R/W	R/W	R/W	R/W	R/W	R/W

15.3.2 Time Constant Register A (TCORA)

TCORA is an 8-bit readable/writable register. TCORA_0 and TCORA_1 comprise a single 16-bit register so they can be accessed together by a word transfer instruction. The value in TCORA is continually compared with the value in TCNT. When a match is detected, the corresponding CMFA flag in TCSR is set to 1. Note however that comparison is disabled during the T2 state of a TCORA write cycle. The timer output from the TMO pin can be freely controlled by this compare match signal (compare match A) and the settings of bits OS1 and OS0 in TCSR. TCORA is initialized to H'FF.

Bit	TCORA_0								TCORA_1							
Bit Name	7	6	5	4	3	2	1	0	7	6	5	4	3	2	1	0
Initial Value	1	1	1	1	1	1	1	1	1	1	1	1	1	1	1	1
R/W	R/W	R/W	R/W	R/W	R/W	R/W	R/W	R/W	R/W	R/W	R/W	R/W	R/W	R/W	R/W	R/W

15.3.3 Time Constant Register B (TCORB)

TCORB is an 8-bit readable/writable register. TCORB_0 and TCORB_1 comprise a single 16-bit register so they can be accessed together by a word transfer instruction. TCORB is continually compared with the value in TCNT. When a match is detected, the corresponding CMFB flag in TCSR is set to 1. Note however that comparison is disabled during the T2 state of a TCORB write cycle. The timer output from the TMO pin can be freely controlled by this compare match signal (compare match B) and the settings of bits OS3 and OS2 in TCSR. TCORB is initialized to H'FF.

Bit	TCORB_0								TCORB_1							
	7	6	5	4	3	2	1	0	7	6	5	4	3	2	1	0
Bit Name																
Initial Value	1	1	1	1	1	1	1	1	1	1	1	1	1	1	1	1
R/W	R/W	R/W	R/W	R/W	R/W	R/W	R/W	R/W	R/W	R/W	R/W	R/W	R/W	R/W	R/W	R/W

15.3.4 Timer Control Register (TCR)

TCR selects the TCNT clock source and the condition for clearing TCNT, and enables/disables interrupt requests.

Bit	7	6	5	4	3	2	1	0
Bit Name	CMIEB	CMIEA	OVIE	CCLR1	CCLR0	CKS2	CKS1	CKS0
Initial Value	0	0	0	0	0	0	0	0
R/W	R/W	R/W	R/W	R/W	R/W	R/W	R/W	R/W

Bit	Bit Name	Initial Value	R/W	Description
7	CMIEB	0	R/W	Compare Match Interrupt Enable B Selects whether CMFB interrupt requests (CMIB) are enabled or disabled when the CMFB flag in TCSR is set to 1. * ² 0: CMFB interrupt requests (CMIB) are disabled 1: CMFB interrupt requests (CMIB) are enabled

Bit	Bit Name	Initial Value	R/W	Description
6	CMIEA	0	R/W	Compare Match Interrupt Enable A Selects whether CMFA interrupt requests (CMIA) are enabled or disabled when the CMFA flag in TCSR is set to 1. * ² 0: CMFA interrupt requests (CMIA) are disabled 1: CMFA interrupt requests (CMIA) are enabled
5	OVIE	0	R/W	Timer Overflow Interrupt Enable* ³ Selects whether OVF interrupt requests (OVI) are enabled or disabled when the OVF flag in TCSR is set to 1. 0: OVF interrupt requests (OVI) are disabled 1: OVF interrupt requests (OVI) are enabled
4	CCLR1	0	R/W	Counter Clear 1 and 0* ¹
3	CCLR0	0	R/W	These bits select the method by which TCNT is cleared. 00: Clearing is disabled 01: Cleared by compare match A 10: Cleared by compare match B 11: Cleared at rising edge (TMRIS in TCCR is cleared to 0) of the external reset input or when the external reset input is high (TMRIS in TCCR is set to 1) * ³
2	CKS2	0	R/W	Clock Select 2 to 0* ¹
1	CKS1	0	R/W	These bits select the clock input to TCNT and count condition. See Table 15.2.
0	CKS0	0	R/W	

- Notes:
1. To use an external reset or external clock, the DDR and ICR bits in the corresponding pin should be set to 0 and 1, respectively. For details, see section 12, I/O Ports.
 2. In unit 2 and unit 3, one interrupt signal is used for CMIEB or CMIEA. For details, see section 15.7, Interrupt Sources.
 3. Available only in unit 0 and unit 1.

15.3.5 Timer Counter Control Register (TCCR)

TCCR selects the TCNT internal clock source and controls external reset input.

Bit	7	6	5	4	3	2	1	0
Bit Name	—	—	—	—	TMRIS	—	ICKS1	ICKS0
Initial Value	0	0	0	0	0	0	0	0
R/W	R	R	R	R	R/W	R	R/W	R/W

Bit	Bit Name	Initial Value	R/W	Description
7 to 4	—	All 0	R	Reserved These bits are always read as 0. It should not be set to 0.
3	TMRIS	0	R/W	Timer Reset Input Select* Selects an external reset input when the CCLR1 and CCLR0 bits in TCR are B'11. 0: Cleared at rising edge of the external reset 1: Cleared when the external reset is high
2	—	0	R	Reserved This bit is always read as 0. It should not be set to 0.
1	ICKS1	0	R/W	Internal Clock Select 1 and 0
0	ICKS0	0	R/W	These bits in combination with bits CKS2 to CKS0 in TCR select the internal clock. See Table 15.2.

Note: * Available only in unit 0 and unit 1. The write value should always be 0 in unit 2 and unit 3.

Table 15.2 Clock Input to TCNT and Count Condition (Unit 0)

Channel	TCR			TCCR		Description
	Bit 2 CKS2	Bit 1 CKS1	Bit 0 CKS0	Bit 1 ICKS1	Bit 0 ICKS0	
TMR_0	0	0	0	—	—	Clock input prohibited
	0	0	1	0	0	Uses internal clock. Counts at rising edge of P ϕ /8.
				0	1	Uses internal clock. Counts at rising edge of P ϕ /2.
				1	0	Uses internal clock. Counts at falling edge of P ϕ /8.
				1	1	Uses internal clock. Counts at falling edge of P ϕ /2.
	0	1	0	0	0	Uses internal clock. Counts at rising edge of P ϕ /64.
				0	1	Uses internal clock. Counts at rising edge of P ϕ /32.
				1	0	Uses internal clock. Counts at falling edge of P ϕ /64.
				1	1	Uses internal clock. Counts at falling edge of P ϕ /32.
	0	1	1	0	0	Uses internal clock. Counts at rising edge of P ϕ /8192.
				0	1	Uses internal clock. Counts at rising edge of P ϕ /1024.
				1	0	Uses internal clock. Counts at falling edge of P ϕ /8192.
				1	1	Uses internal clock. Counts at falling edge of P ϕ /1024.
1	0	0	—	—	Counts at TCNT_1 overflow signal* ¹ .	
TMR_1	0	0	0	—	—	Clock input prohibited
	0	0	1	0	0	Uses internal clock. Counts at rising edge of P ϕ /8.
				0	1	Uses internal clock. Counts at rising edge of P ϕ /2.
				1	0	Uses internal clock. Counts at falling edge of P ϕ /8.
				1	1	Uses internal clock. Counts at falling edge of P ϕ /2.
	0	1	0	0	0	Uses internal clock. Counts at rising edge of P ϕ /64.
				0	1	Uses internal clock. Counts at rising edge of P ϕ /32.
				1	0	Uses internal clock. Counts at falling edge of P ϕ /64.
				1	1	Uses internal clock. Counts at falling edge of P ϕ /32.
	0	1	1	0	0	Uses internal clock. Counts at rising edge of P ϕ /8192.
				0	1	Uses internal clock. Counts at rising edge of P ϕ /1024.
				1	0	Uses internal clock. Counts at falling edge of P ϕ /8192.
				1	1	Uses internal clock. Counts at falling edge of P ϕ /1024.
1	0	0	—	—	Counts at TCNT_0 compare match A* ¹ .	
All	1	0	1	—	—	Uses external clock. Counts at rising edge* ² .
	1	1	0	—	—	Uses external clock. Counts at falling edge* ² .
	1	1	1	—	—	Uses external clock. Counts at both rising and falling edges* ² .

Notes: 1. If the clock input of channel 0 is the TCNT_1 overflow signal and that of channel 1 is the TCNT_0 compare match signal, no incrementing clock is generated. Do not use this setting.

2. To use the external clock, the DDR and ICR bits in the corresponding pin should be set to 0 and 1, respectively. For details, see section 12, I/O Ports.

Table 15.3 Clock Input to TCNT and Count Condition (Unit 1)

Channel	TCR			TCCR		Description	
	Bit 2 CKS2	Bit 1 CKS1	Bit 0 CKS0	Bit 1 ICKS1	Bit 0 ICKS0		
TMR_2	0	0	0	—	—	Clock input prohibited	
	0	0	1	0	0	Uses internal clock. Counts at rising edge of P ϕ /8.	
				0	1	Uses internal clock. Counts at rising edge of P ϕ /2.	
				1	0	Uses internal clock. Counts at falling edge of P ϕ /8.	
				1	1	Uses internal clock. Counts at falling edge of P ϕ /2.	
	0	1	0	0	0	Uses internal clock. Counts at rising edge of P ϕ /64.	
				0	1	Uses internal clock. Counts at rising edge of P ϕ /32.	
				1	0	Uses internal clock. Counts at falling edge of P ϕ /64.	
				1	1	Uses internal clock. Counts at falling edge of P ϕ /32.	
	0	1	1	0	0	Uses internal clock. Counts at rising edge of P ϕ /8192.	
				0	1	Uses internal clock. Counts at rising edge of P ϕ /1024.	
				1	0	Uses internal clock. Counts at falling edge of P ϕ /8192.	
				1	1	Uses internal clock. Counts at falling edge of P ϕ /1024.	
	1	0	0	—	—	Counts at TCNT_3 overflow signal* ¹ .	
	TMR_3	0	0	0	—	—	Clock input prohibited
		0	0	1	0	0	Uses internal clock. Counts at rising edge of P ϕ /8.
0					1	Uses internal clock. Counts at rising edge of P ϕ /2.	
1					0	Uses internal clock. Counts at falling edge of P ϕ /8.	
1					1	Uses internal clock. Counts at falling edge of P ϕ /2.	
0		1	0	0	0	Uses internal clock. Counts at rising edge of P ϕ /64.	
				0	1	Uses internal clock. Counts at rising edge of P ϕ /32.	
				1	0	Uses internal clock. Counts at falling edge of P ϕ /64.	
				1	1	Uses internal clock. Counts at falling edge of P ϕ /32.	
0		1	1	0	0	Uses internal clock. Counts at rising edge of P ϕ /8192.	
				0	1	Uses internal clock. Counts at rising edge of P ϕ /1024.	
				1	0	Uses internal clock. Counts at falling edge of P ϕ /8192.	
				1	1	Uses internal clock. Counts at falling edge of P ϕ /1024.	
1		0	0	—	—	Counts at TCNT_2 compare match A* ¹ .	
All		1	0	1	—	—	Uses external clock. Counts at rising edge* ² .
		1	1	0	—	—	Uses external clock. Counts at falling edge* ² .
	1	1	1	—	—	Uses external clock. Counts at both rising and falling edges* ² .	

- Notes: 1. If the clock input of channel 2 is the TCNT_3 overflow signal and that of channel 3 is the TCNT_2 compare match signal, no incrementing clock is generated. Do not use this setting.
2. To use the external clock, the DDR and ICR bits in the corresponding pin should be set to 0 and 1, respectively. For details, see section 12, I/O Ports.

Table 15.4 Clock Input to TCNT and Count Condition (Unit 2)

Channel	TCR			TCCR		Description
	Bit 2 CKS2	Bit 1 CKS1	Bit 0 CKS0	Bit 1 ICKS1	Bit 0 ICKS0	
TMR_4	0	0	0	—	—	Clock input prohibited
	0	0	1	0	0	Uses internal clock. Counts at rising edge of P ϕ /8.
				0	1	Uses internal clock. Counts at rising edge of P ϕ /2.
				1	0	Uses internal clock. Counts at falling edge of P ϕ /8.
				1	1	Uses internal clock. Counts at falling edge of P ϕ /2.
	0	1	0	0	0	Uses internal clock. Counts at rising edge of P ϕ /64.
				0	1	Uses internal clock. Counts at rising edge of P ϕ /32.
				1	0	Uses internal clock. Counts at falling edge of P ϕ /64.
				1	1	Uses internal clock. Counts at falling edge of P ϕ /32.
	0	1	1	0	0	Uses internal clock. Counts at rising edge of P ϕ /8192.
				0	1	Uses internal clock. Counts at rising edge of P ϕ /1024.
				1	0	Uses internal clock. Counts at rising edge of P ϕ .
				1	1	Uses internal clock. Counts at falling edge of P ϕ /1024.
	1	0	0	—	—	Counts at TCNT_5 overflow signal*.
	TMR_5	0	0	0	—	—
0		0	1	0	0	Uses internal clock. Counts at rising edge of P ϕ /8.
				0	1	Uses internal clock. Counts at rising edge of P ϕ /2.
				1	0	Uses internal clock. Counts at falling edge of P ϕ /8.
				1	1	Uses internal clock. Counts at falling edge of P ϕ /2.
0		1	0	0	0	Uses internal clock. Counts at rising edge of P ϕ /64.
				0	1	Uses internal clock. Counts at rising edge of P ϕ /32.
				1	0	Uses internal clock. Counts at falling edge of P ϕ /64.
				1	1	Uses internal clock. Counts at falling edge of P ϕ /32.
0		1	1	0	0	Uses internal clock. Counts at rising edge of P ϕ /8192.
				0	1	Uses internal clock. Counts at rising edge of P ϕ /1024.
				1	0	Uses internal clock. Counts at rising edge of P ϕ .
				1	1	Uses internal clock. Counts at falling edge of P ϕ /1024.
1		0	0	—	—	Counts at TCNT_4 compare match A*.
All		1	0	1	—	—
	1	1	0	—	—	Setting prohibited
	1	1	1	—	—	Setting prohibited

Note: * If the clock input of channel 4 is the TCNT_5 overflow signal and that of channel 5 is the TCNT_4 compare match signal, no incrementing clock is generated. Do not use this setting.

Table 15.5 Clock Input to TCNT and Count Condition (Unit 3)

Channel	TCR			TCCR		Description
	Bit 2 CKS2	Bit 1 CKS1	Bit 0 CKS0	Bit 1 ICKS1	Bit 0 ICKS0	
TMR_6	0	0	0	—	—	Clock input prohibited
	0	0	1	0	0	Uses internal clock. Counts at rising edge of P ϕ /8.
				0	1	Uses internal clock. Counts at rising edge of P ϕ /2.
				1	0	Uses internal clock. Counts at falling edge of P ϕ /8.
				1	1	Uses internal clock. Counts at falling edge of P ϕ /2.
	0	1	0	0	0	Uses internal clock. Counts at rising edge of P ϕ /64.
				0	1	Uses internal clock. Counts at rising edge of P ϕ /32.
				1	0	Uses internal clock. Counts at falling edge of P ϕ /64.
				1	1	Uses internal clock. Counts at falling edge of P ϕ /32.
	0	1	1	0	0	Uses internal clock. Counts at rising edge of P ϕ /8192.
				0	1	Uses internal clock. Counts at rising edge of P ϕ /1024.
				1	0	Uses internal clock. Counts at rising edge of P ϕ .
				1	1	Uses internal clock. Counts at falling edge of P ϕ /1024.
	1	0	0	—	—	Counts at TCNT_7 overflow signal*.
	TMR_7	0	0	0	—	—
0		0	1	0	0	Uses internal clock. Counts at rising edge of P ϕ /8.
				0	1	Uses internal clock. Counts at rising edge of P ϕ /2.
				1	0	Uses internal clock. Counts at falling edge of P ϕ /8.
				1	1	Uses internal clock. Counts at falling edge of P ϕ /2.
0		1	0	0	0	Uses internal clock. Counts at rising edge of P ϕ /64.
				0	1	Uses internal clock. Counts at rising edge of P ϕ /32.
				1	0	Uses internal clock. Counts at falling edge of P ϕ /64.
				1	1	Uses internal clock. Counts at falling edge of P ϕ /32.
0		1	1	0	0	Uses internal clock. Counts at rising edge of P ϕ /8192.
				0	1	Uses internal clock. Counts at rising edge of P ϕ /1024.
				1	0	Uses internal clock. Counts at rising edge of P ϕ .
				1	1	Uses internal clock. Counts at falling edge of P ϕ /1024.
1		0	0	—	—	Counts at TCNT_6 compare match A*.
All		1	0	1	—	—
	1	1	0	—	—	Setting prohibited
	1	1	1	—	—	Setting prohibited

Note: * If the clock input of channel 6 is the TCNT_7 overflow signal and that of channel 7 is the TCNT_6 compare match signal, no incrementing clock is generated. Do not use this setting.

15.3.6 Timer Control/Status Register (TCSR)

TCSR displays status flags, and controls compare match output.

- TCSR_0

Bit	7	6	5	4	3	2	1	0
Bit Name	CMFB	CMFA	OVF	ADTE	OS3	OS2	OS1	OS0
Initial Value	0	0	0	0	0	0	0	0
R/W	R/(W)*	R/(W)*	R/(W)*	R/W	R/W	R/W	R/W	R/W

- TCSR_1

Bit	7	6	5	4	3	2	1	0
Bit Name	CMFB	CMFA	OVF	—	OS3	OS2	OS1	OS0
Initial Value	0	0	0	1	0	0	0	0
R/W	R/(W)*	R/(W)*	R/(W)*	R	R/W	R/W	R/W	R/W

Note: * Only 0 can be written to this bit, to clear the flag.

- TCSR_0

Bit	Bit Name	Initial Value	R/W	Description
7	CMFB	0	R/(W)* ¹	Compare Match Flag B [Setting condition] <ul style="list-style-type: none"> • When TCNT matches TCORB [Clearing conditions] <ul style="list-style-type: none"> • When writing 0 after reading CMFB = 1 (When the CPU is used to clear this flag by writing 0 while the corresponding interrupt is enabled, be sure to read the flag after writing 0 to it.) • When the DTC is activated by a CMIB interrupt while the DISEL bit in MRB of the DTC is 0*³

Bit	Bit Name	Initial Value	R/W	Description
6	CMFA	0	R/(W)* ¹	<p>Compare Match Flag A</p> <p>[Setting condition]</p> <ul style="list-style-type: none"> When TCNT matches TCORA <p>[Clearing conditions]</p> <ul style="list-style-type: none"> When writing 0 after reading CMFA = 1 (When the CPU is used to clear this flag by writing 0 while the corresponding interrupt is enabled, be sure to read the flag after writing 0 to it.) When the DTC is activated by a CMIA interrupt while the DISEL bit in MRB in the DTC is 0*³
5	OVF	0	R/(W)* ¹	<p>Timer Overflow Flag</p> <p>[Setting condition]</p> <p>When TCNT overflows from H'FF to H'00</p> <p>[Clearing condition]</p> <p>When writing 0 after reading OVF = 1 (When the CPU is used to clear this flag by writing 0 while the corresponding interrupt is enabled, be sure to read the flag after writing 0 to it.)</p>
4	ADTE	0	R/W	<p>A/D Trigger Enable*³</p> <p>Selects enabling or disabling of A/D converter start requests by compare match A.</p> <p>0: A/D converter start requests by compare match A are disabled</p> <p>1: A/D converter start requests by compare match A are enabled</p>
3	OS3	0	R/W	Output Select 3 and 2* ²
2	OS2	0	R/W	<p>These bits select a method of TMO pin output when compare match B of TCORB and TCNT occurs.</p> <p>00: No change when compare match B occurs</p> <p>01: 0 is output when compare match B occurs</p> <p>10: 1 is output when compare match B occurs</p> <p>11: Output is inverted when compare match B occurs (toggle output)</p>

Bit	Bit Name	Initial Value	R/W	Description
1	OS1	0	R/W	Output Select 1 and 0* ²
0	OS0	0	R/W	These bits select a method of TMO pin output when compare match A of TCORA and TCNT occurs. 00: No change when compare match A occurs 01: 0 is output when compare match A occurs 10: 1 is output when compare match A occurs 11: Output is inverted when compare match A occurs (toggle output)

- Notes:
1. Only 0 can be written to bits 7 to 5, to clear these flags.
 2. Timer output is disabled when bits OS3 to OS0 are all 0. Timer output is 0 until the first compare match occurs after a reset.
 3. For the corresponding A/D converter channels, see section 19, A/D Converter.

- TCSR_1

Bit	Bit Name	Initial Value	R/W	Description
7	CMFB	0	R/(W)* ¹	Compare Match Flag B [Setting condition] <ul style="list-style-type: none"> • When TCNT matches TCORB [Clearing conditions] <ul style="list-style-type: none"> • When writing 0 after reading CMFB = 1 (When the CPU is used to clear this flag by writing 0 while the corresponding interrupt is enabled, be sure to read the flag after writing 0 to it.) • When the DTC is activated by a CMIB interrupt while the DISEL bit in MRB of the DTC is 0*³

Bit	Bit Name	Initial Value	R/W	Description
6	CMFA	0	R/(W)* ¹	<p>Compare Match Flag A</p> <p>[Setting condition]</p> <ul style="list-style-type: none"> When TCNT matches TCORA <p>[Clearing conditions]</p> <ul style="list-style-type: none"> When writing 0 after reading CMFA = 1 (When the CPU is used to clear this flag by writing 0 while the corresponding interrupt is enabled, be sure to read the flag after writing 0 to it.) When the DTC is activated by a CMIA interrupt while the DISEL bit in MRB of the DTC is 0*³
5	OVF	0	R/(W)* ¹	<p>Timer Overflow Flag</p> <p>[Setting condition]</p> <p>When TCNT overflows from H'FF to H'00</p> <p>[Clearing condition]</p> <p>Cleared by reading OVF when OVF = 1, then writing 0 to OVF</p> <p>(When the CPU is used to clear this flag by writing 0 while the corresponding interrupt is enabled, be sure to read the flag after writing 0 to it.)</p>
4	—	1	R	<p>Reserved</p> <p>This bit is always read as 1 and cannot be modified.</p>
3	OS3	0	R/W	Output Select 3 and 2* ²
2	OS2	0	R/W	<p>These bits select a method of TMO pin output when compare match B of TCORB and TCNT occurs.</p> <p>00: No change when compare match B occurs</p> <p>01: 0 is output when compare match B occurs</p> <p>10: 1 is output when compare match B occurs</p> <p>11: Output is inverted when compare match B occurs (toggle output)</p>

Bit	Bit Name	Initial Value	R/W	Description
1	OS1	0	R/W	Output Select 1 and 0* ²
0	OS0	0	R/W	These bits select a method of TMO pin output when compare match A of TCORA and TCNT occurs. 00: No change when compare match A occurs 01: 0 is output when compare match A occurs 10: 1 is output when compare match A occurs 11: Output is inverted when compare match A occurs (toggle output)

- Notes:
1. Only 0 can be written to bits 7 to 5, to clear these flags.
 2. Timer output is disabled when bits OS3 to OS0 are all 0. Timer output is 0 until the first compare match occurs after a reset.
 3. Available only in unit 0 and unit 1.

15.4 Operation

15.4.1 Pulse Output

Figure 15.5 shows an example of the 8-bit timer being used to generate a pulse output with a desired duty cycle. The control bits are set as follows:

1. Clear the bit CCLR1 in TCR to 0 and set the bit CCLR0 in TCR to 1 so that TCNT is cleared at a TCORA compare match.
2. Set the bits OS3 to OS0 in TCSR to B'0110, causing the output to change to 1 at a TCORA compare match and to 0 at a TCORB compare match.

With these settings, the 8-bit timer provides pulses output at a cycle determined by TCORA with a pulse width determined by TCORB. No software intervention is required. The timer output is 0 until the first compare match occurs after a reset.

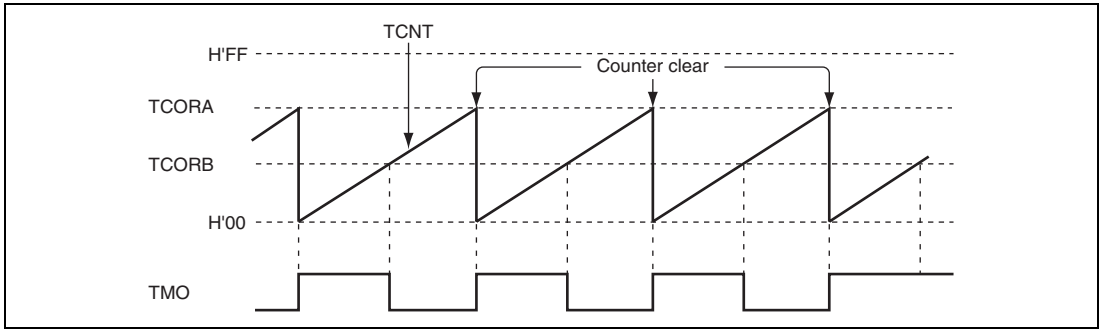

Figure 15.5 Example of Pulse Output

15.4.2 Reset Input

Figure 15.6 shows an example of the 8-bit timer being used to generate a pulse which is output after a desired delay time from a TMRI input. The control bits are set as follows:

1. Set both bits CCLR1 and CCLR0 in TCR to 1 and set the TMRIS bit in TCCR to 1 so that TCNT is cleared at the high level input of the TMRI signal.
2. In TCSR, set bits OS3 to OS0 to B'0110, causing the output to change to 1 at a TCORA compare match and to 0 at a TCORB compare match.

With these settings, the 8-bit timer provides pulses output at a desired delay time from a TMRI input determined by TCORA and with a pulse width determined by TCORB and TCORA.

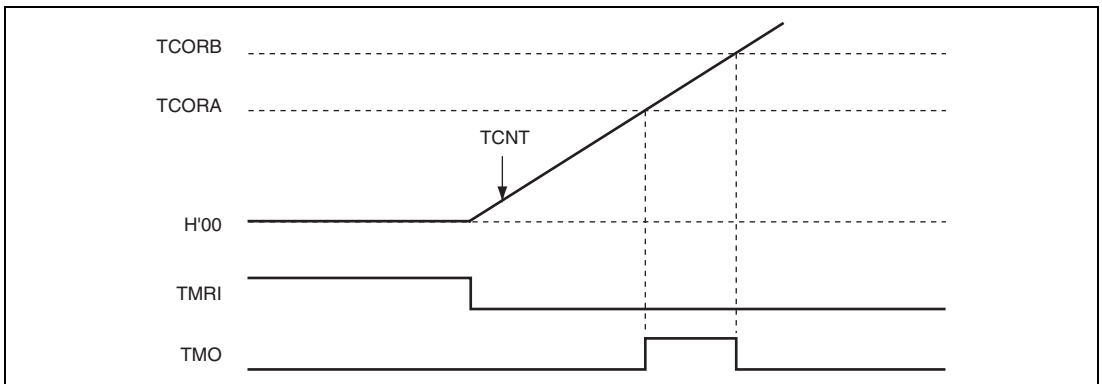

Figure 15.6 Example of Reset Input

15.5 Operation Timing

15.5.1 TCNT Count Timing

Figure 15.7 shows the TCNT count timing for internal clock input. Figure 15.8 shows the TCNT count timing for external clock input. Note that the external clock pulse width must be at least 1.5 states for increment at a single edge, and at least 2.5 states for increment at both edges. The counter will not increment correctly if the pulse width is less than these values.

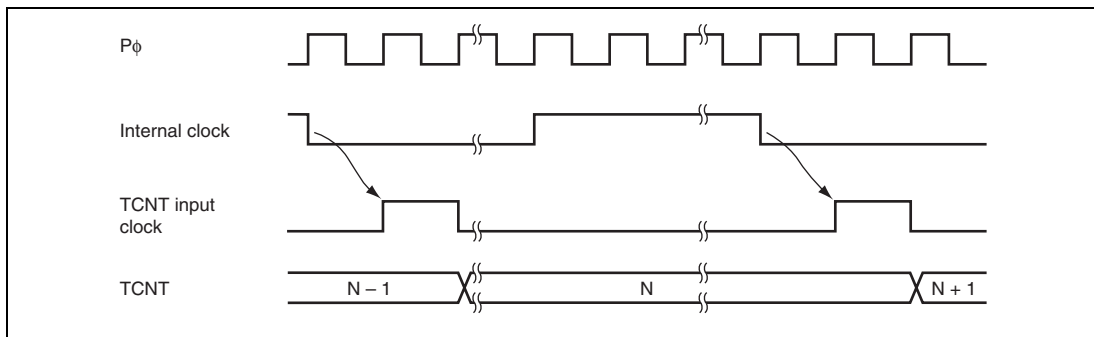

Figure 15.7 Count Timing for Internal Clock Input

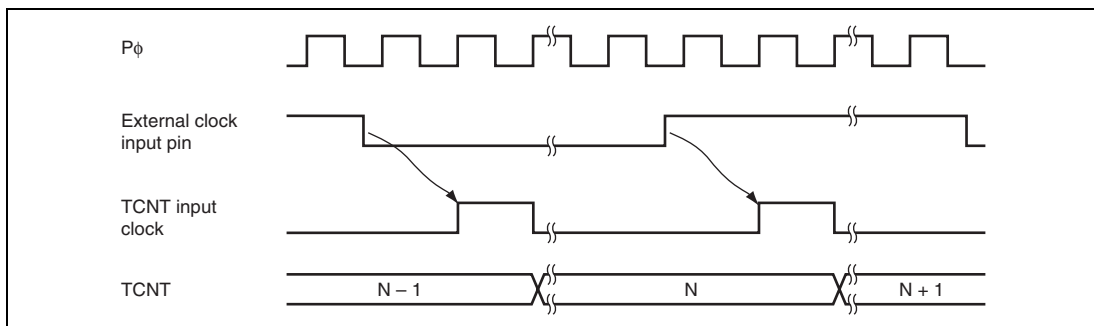

Figure 15.8 Count Timing for External Clock Input

15.5.2 Timing of CMFA and CMFB Setting at Compare Match

The CMFA and CMFB flags in TCSR are set to 1 by a compare match signal generated when the TCOR and TCNT values match. The compare match signal is generated at the last state in which the match is true, just before the timer counter is updated. Therefore, when the TCOR and TCNT values match, the compare match signal is not generated until the next TCNT clock input. Figure 15.9 shows this timing.

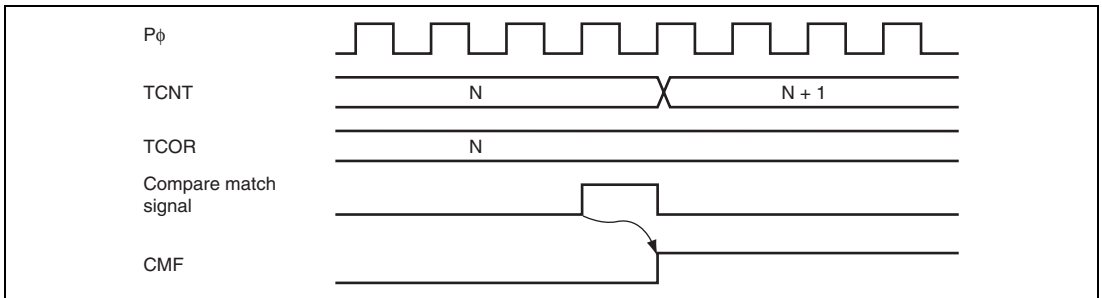

Figure 15.9 Timing of CMF Setting at Compare Match

15.5.3 Timing of Timer Output at Compare Match

When a compare match signal is generated, the timer output changes as specified by the bits OS3 to OS0 in TCSR. Figure 15.10 shows the timing when the timer output is toggled by the compare match A signal.

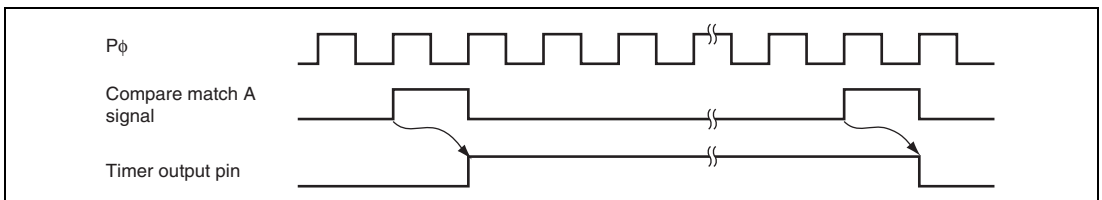

Figure 15.10 Timing of Toggled Timer Output at Compare Match A

15.5.4 Timing of Counter Clear by Compare Match

TCNT is cleared when compare match A or B occurs, depending on the settings of the bits CCLR1 and CCLR0 in TCR. Figure 15.11 shows the timing of this operation.

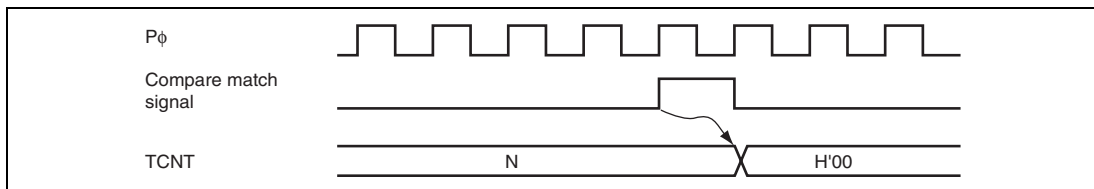

Figure 15.11 Timing of Counter Clear by Compare Match

15.5.5 Timing of TCNT External Reset*

TCNT is cleared at the rising edge or high level of an external reset input, depending on the settings of bits CCLR1 and CCLR0 in TCR. The clear pulse width must be at least 2 states. Figure 15.12 and Figure 15.13 shows the timing of this operation.

Note: * Clearing by an external reset is available only in units 0 and 1.

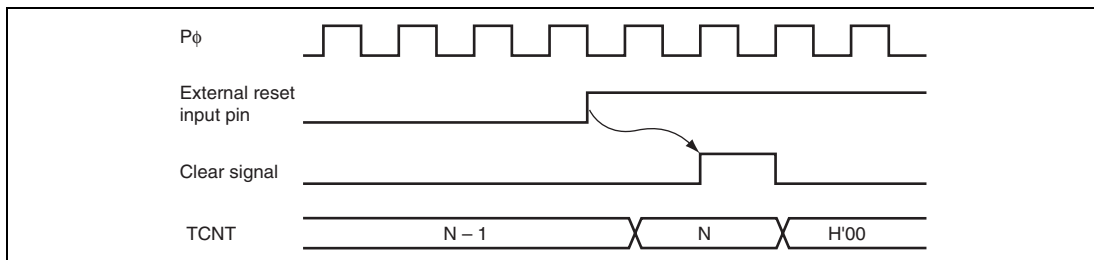

Figure 15.12 Timing of Clearance by External Reset (Rising Edge)

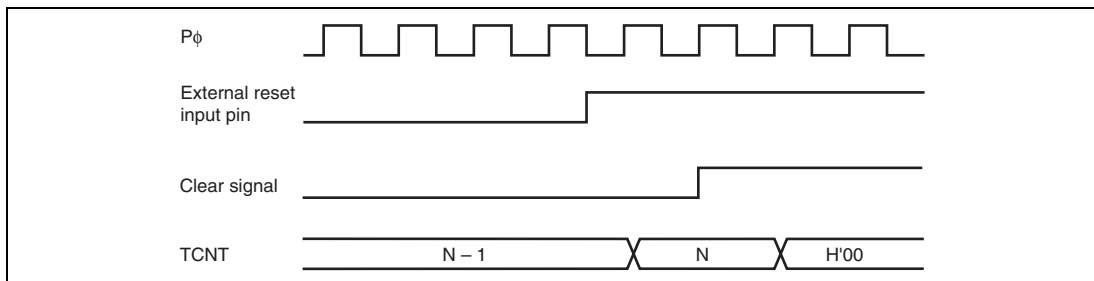

Figure 15.13 Timing of Clearance by External Reset (High Level)

15.5.6 Timing of Overflow Flag (OVF) Setting

The OVF bit in TCSR is set to 1 when TCNT overflows (changes from H'FF to H'00). Figure 15.14 shows the timing of this operation.

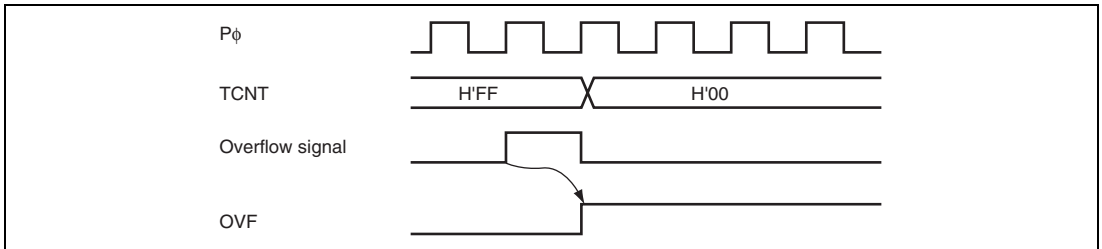

Figure 15.14 Timing of OVF Setting

15.6 Operation with Cascaded Connection

If the bits CKS2 to CKS0 in either TCR_0 or TCR_1 are set to B'100, the 8-bit timers of the two channels are cascaded. With this configuration, a single 16-bit timer could be used (16-bit counter mode) or compare matches of the 8-bit channel 0 could be counted by the timer of channel 1 (compare match count mode).

15.6.1 16-Bit Counter Mode

When the bits CKS2 to CKS0 in TCR_0 are set to B'100, the timer functions as a single 16-bit timer with channel 0 occupying the upper 8 bits and channel 1 occupying the lower 8 bits.

(1) Setting of Compare Match Flags

- The CMF flag in TCSR_0 is set to 1 when a 16-bit compare match event occurs.
- The CMF flag in TCSR_1 is set to 1 when a lower 8-bit compare match event occurs.

(2) Counter Clear Specification

- If the CCLR1 and CCLR0 bits in TCR_0 have been set for counter clear at compare match, the 16-bit counter (TCNT_0 and TCNT_1 together) is cleared when a 16-bit compare match event occurs. The 16-bit counter (TCNT0 and TCNT1 together) is cleared even if counter clear by the TMRI0 pin has been set.
- The settings of the CCLR1 and CCLR0 bits in TCR_1 are ignored. The lower 8 bits cannot be cleared independently.

(3) Pin Output

- Control of output from the TMO0 pin by the bits OS3 to OS0 in TCSR_0 is in accordance with the 16-bit compare match conditions.
- Control of output from the TMO1 pin by the bits OS3 to OS0 in TCSR_1 is in accordance with the lower 8-bit compare match conditions.

15.6.2 Compare Match Count Mode

When the bits CKS2 to CKS0 in TCR_1 are set to B'100, TCNT_1 counts compare match A for channel 0. Channels 0 and 1 are controlled independently. Conditions such as setting of the CMF flag, generation of interrupts, output from the TMO pin, and counter clear are in accordance with the settings for each channel.

15.7 Interrupt Sources

15.7.1 Interrupt Sources and DTC Activation

- Interrupt in unit 0 and unit 1

There are three interrupt sources for the 8-bit timer (TMR_0 or TMR_1): CMIA, CMIB, and OVI. Their interrupt sources and priorities are shown in Table 15.6. Each interrupt source is enabled or disabled by the corresponding interrupt enable bit in TCR or TCSR, and independent interrupt requests are sent for each to the interrupt controller. It is also possible to activate the DTC by means of CMIA and CMIB interrupts (This is available in unit 0 and unit 1 only).

Table 15.6 8-Bit Timer (TMR_0 or TMR_1) Interrupt Sources (in Unit 0 and Unit 1)

Signal Name	Name	Interrupt Source	Interrupt Flag	DTC Activation	Priority
CMIA0	CMIA0	TCORA_0 compare match	CMFA	Possible	High
CMIB0	CMIB0	TCORB_0 compare match	CMFB	Possible	↑ High
OVI0	OVI0	TCNT_0 overflow	OVF	Not possible	Low
CMIA1	CMIA1	TCORA_1 compare match	CMFA	Possible	High
CMIB1	CMIB1	TCORB_1 compare match	CMFB	Possible	↑ High
OVI1	OVI1	TCNT_1 overflow	OVF	Not possible	Low

- Interrupt in unit 2 and unit 3

There are two interrupt sources for the 8-bit timer (TMR_4 or TMR_5): CMIA, CMIB. The interrupt signal is CMI only. The interrupt sources are shown in Table 15.7. When enabling or disabling is set by the interrupt enable bit in TCR or TCSR, and when either CMIA or CMIB interrupt source is generated, CMI is sent to the interrupt controller. To verify which interrupt source is generated, confirm by checking each flag in TCSR. No overflow-related interrupt signal exists. DTC cannot be activated by this interrupt.

Table 15.7 8-Bit Timer (TMR_4 or TMR_5) Interrupt Sources (in Unit 2 and Unit 3)

Signal Name	Name	Interrupt Source	Interrupt Flag	DTC Activation	Priority
CMI4	CMIA4	TCORA_4 compare match	CMFA	Not possible	—
	CMIB4	TCORB_4 compare match	CMFB		
CMI5	CMIA5	TCORA_5 compare match	CMFA	Not possible	—
	CMIB5	TCORB_5 compare match	CMFB		

15.7.2 A/D Converter Activation

The A/D converter can be activated by a compare match A for the even channels of each TMR unit. *

If the ADTE bit in TCSR is set to 1 when the CMFA flag in TCSR is set to 1 by the occurrence of a compare match A, a request to start A/D conversion is sent to the A/D converter. If the 8-bit timer conversion start trigger has been selected on the A/D converter side at this time, A/D conversion is started.

Note: * For the corresponding A/D converter channels, see section 19, A/D Converter.

15.8 Usage Notes

15.8.1 Notes on Setting Cycle

If the compare match is selected for counter clear, TCNT is cleared at the last state in the cycle in which the values of TCNT and TCOR match. TCNT updates the counter value at this last state. Therefore, the counter frequency is obtained by the following formula.

$$f = \phi / (N + 1)$$

f: Counter frequency
 ϕ : Operating frequency
 N: TCOR value

15.8.2 Conflict between TCNT Write and Counter Clear

If a counter clear signal is generated during the T_2 state of a TCNT write cycle, the clear takes priority and the write is not performed as shown in Figure 15.15.

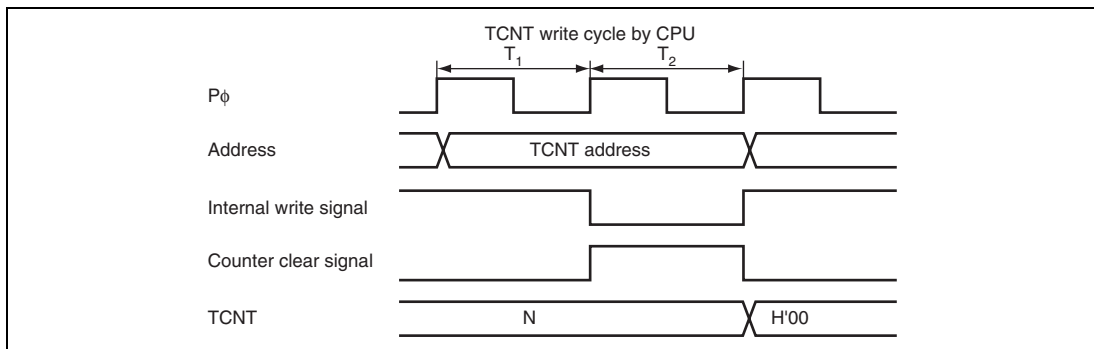

Figure 15.15 Conflict between TCNT Write and Clear

15.8.3 Conflict between TCNT Write and Increment

If a TCNT input clock pulse is generated during the T_2 state of a TCNT write cycle, the write takes priority and the counter is not incremented as shown in Figure 15.16.

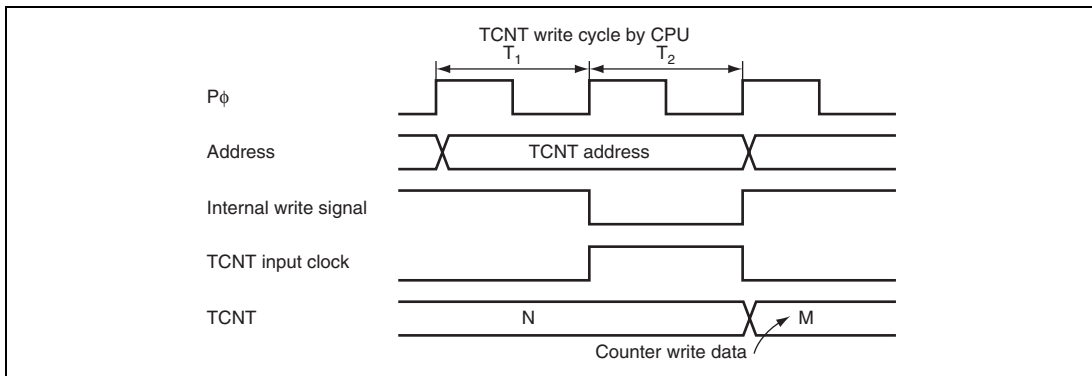

Figure 15.16 Conflict between TCNT Write and Increment

15.8.4 Conflict between TCOR Write and Compare Match

If a compare match event occurs during the T_2 state of a TCOR write cycle, the TCOR write takes priority and the compare match signal is inhibited as shown in Figure 15.17.

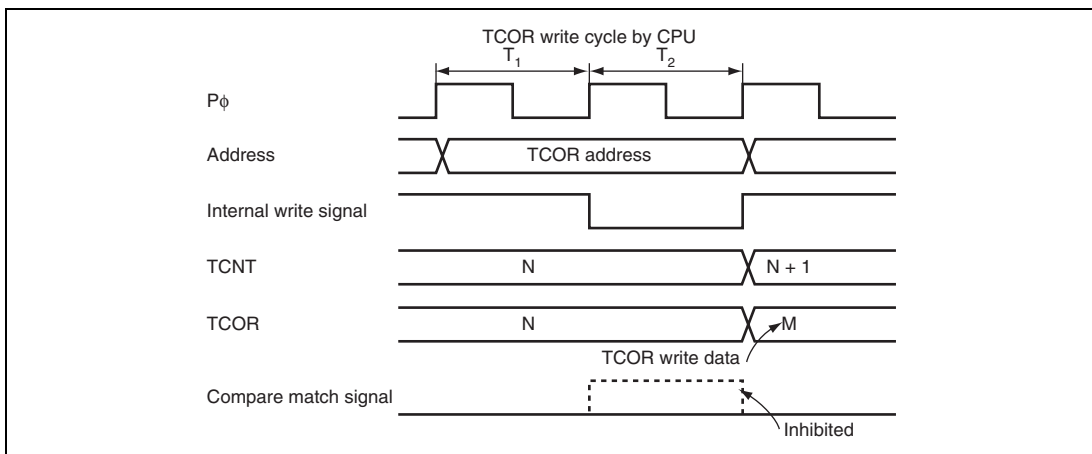

Figure 15.17 Conflict between TCOR Write and Compare Match

15.8.5 Conflict between Compare Matches A and B

If compare match events A and B occur at the same time, the 8-bit timer operates in accordance with the priorities for the output statuses set for compare match A and compare match B, as shown in Table 15.8.

Table 15.8 Timer Output Priorities

Output Setting	Priority
Toggle output	High
1-output	↑
0-output	
No change	Low

15.8.6 Switching of Internal Clocks and TCNT Operation

TCNT may be incremented erroneously depending on when the internal clock is switched. Table 15.9 shows the relationship between the timing at which the internal clock is switched (by writing to the bits CKS1 and CKS0) and the TCNT operation.

When the TCNT clock is generated from an internal clock, the rising or falling edge of the internal clock pulse are always monitored. Table 15.9 assumes that the falling edge is selected. If the signal levels of the clocks before and after switching change from high to low as shown in item 3, the change is considered as the falling edge. Therefore, a TCNT clock pulse is generated and TCNT is incremented. This is similar to when the rising edge is selected.

The erroneous increment of TCNT can also happen when switching between rising and falling edges of the internal clock, and when switching between internal and external clocks.

Table 15.9 Switching of Internal Clock and TCNT Operation

No.	Timing to Change CKS1 and CKS0 Bits	TCNT Clock Operation
1	Switching from low to low* ¹	<p data-bbox="699 459 852 480">CKS bits changed</p>
2	Switching from low to high* ²	<p data-bbox="816 715 969 735">CKS bits changed</p>
3	Switching from high to low* ³	<p data-bbox="759 970 912 991">CKS bits changed</p>
4	Switching from high to high	<p data-bbox="888 1225 1041 1246">CKS bits changed</p>

Notes: 1. Includes switching from low to stop, and from stop to low.

2. Includes switching from stop to high.

3. Includes switching from high to stop.

4. Generated because the change of the signal levels is considered as a falling edge; TCNT is incremented.

15.8.7 Mode Setting with Cascaded Connection

If 16-bit counter mode and compare match count mode are specified at the same time, input clocks for TCNT_0 and TCNT_1 are not generated, and the counter stops. Do not specify 16-bit counter mode and compare match count mode simultaneously.

15.8.8 Module Stop State Setting

Operation of the TMR can be disabled or enabled using the module stop control register. The initial setting is for operation of the TMR to be halted. Register access is enabled by clearing the module stop state. For details, see section 25, Power-Down Modes.

15.8.9 Interrupts in Module Stop State

If the module stop state is entered when an interrupt has been requested, it will not be possible to clear the CPU interrupt source or the DTC activation source. Interrupts should therefore be disabled before entering the module stop state.

Section 16 Watchdog Timer (WDT)

The watchdog timer (WDT) is an 8-bit timer that outputs an overflow signal ($\overline{\text{WDTOVF}}$) if a system crash prevents the CPU from writing to the timer counter, thus allowing it to overflow. At the same time, the WDT can also generate an internal reset signal.

When this watchdog function is not needed, the WDT can be used as an interval timer. In interval timer operation, an interval timer interrupt is generated each time the counter overflows.

Figure 16.1 shows a block diagram of the WDT.

16.1 Features

- Selectable from eight counter input clocks
- Switchable between watchdog timer mode and interval timer mode
 - In watchdog timer mode
 - If the counter overflows, the WDT outputs $\overline{\text{WDTOVF}}$. It is possible to select whether or not the entire LSI is reset at the same time.
 - In interval timer mode
 - If the counter overflows, the WDT generates an interval timer interrupt (WOVI).

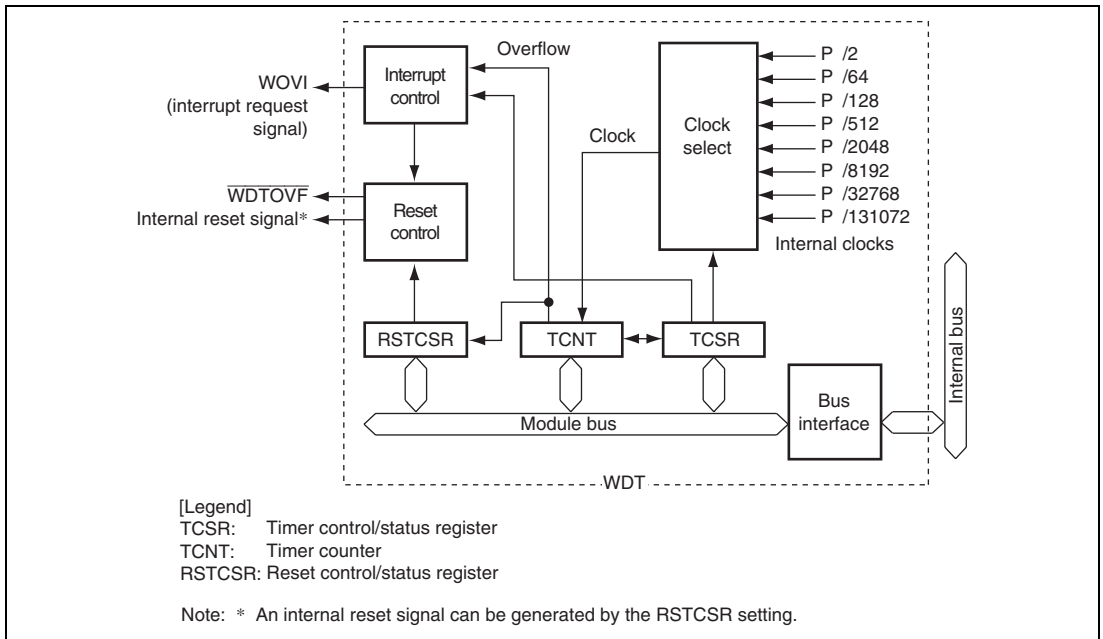

Figure 16.1 Block Diagram of WDT

16.2 Input/Output Pin

Table 16.1 shows the WDT pin configuration.

Table 16.1 Pin Configuration

Name	Symbol	I/O	Function
Watchdog timer overflow*	WDTOVF	Output	Outputs a counter overflow signal in watchdog timer mode

Note: * In boundary scan valid mode, counter overflow signal output cannot be used.

16.3 Register Descriptions

The WDT has the following three registers. To prevent accidental overwriting, TCSR, TCNT, and RSTCSR have to be written to in a method different from normal registers. For details, see section 16.6.1, Notes on Register Access.

- Timer counter (TCNT)
- Timer control/status register (TCSR)
- Reset control/status register (RSTCSR)

16.3.1 Timer Counter (TCNT)

TCNT is an 8-bit readable/writable up-counter. TCNT is initialized to H'00 when the TME bit in TCSR is cleared to 0.

Bit	7	6	5	4	3	2	1	0
Bit Name								
Initial Value	0	0	0	0	0	0	0	0
R/W	R/W	R/W	R/W	R/W	R/W	R/W	R/W	R/W

16.3.2 Timer Control/Status Register (TCSR)

TCSR selects the clock source to be input to TCNT, and the timer mode.

Bit	7	6	5	4	3	2	1	0
Bit Name	OVF	WT/ \overline{IT}	TME	—	—	CKS2	CKS1	CKS0
Initial Value	0	0	0	1	1	0	0	0
R/W	R/(W)*	R/W	R/W	R	R	R/W	R/W	R/W

Note: * Only 0 can be written to this bit, to clear the flag.

Bit	Bit Name	Initial Value	R/W	Description
7	OVF	0	R/(W)*	<p>Overflow Flag</p> <p>Indicates that TCNT has overflowed in interval timer mode. Only 0 can be written to this bit, to clear the flag.</p> <p>[Setting condition]</p> <p>When TCNT overflows in interval timer mode (changes from H'FF to H'00)</p> <p>When internal reset request generation is selected in watchdog timer mode, OVF is cleared automatically by the internal reset.</p> <p>[Clearing condition]</p> <p>Cleared by reading TCSR when OVF = 1, then writing 0 to OVF</p>
6	WT/ $\overline{\text{IT}}$	0	R/W	<p>Timer Mode Select</p> <p>Selects whether the WDT is used as a watchdog timer or interval timer.</p> <p>0: Interval timer mode</p> <p>When TCNT overflows, an interval timer interrupt (WOVI) is requested.</p> <p>1: Watchdog timer mode</p> <p>When TCNT overflows, the $\overline{\text{WDTOVF}}$ signal is output.</p>
5	TME	0	R/W	<p>Timer Enable</p> <p>When this bit is set to 1, TCNT starts counting. When this bit is cleared, TCNT stops counting and is initialized to H'00.</p>
4, 3	—	All 1	R	<p>Reserved</p> <p>These are read-only bits and cannot be modified.</p>
2	CKS2	0	R/W	Clock Select 2 to 0
1	CKS1	0	R/W	Select the clock source to be input to TCNT. The overflow cycle for $P\phi = 20$ MHz is indicated in parentheses.
0	CKS0	0	R/W	<p>000: Clock $P\phi/2$ (cycle: 25.6 μs)</p> <p>001: Clock $P\phi/64$ (cycle: 819.2 μs)</p> <p>010: Clock $P\phi/128$ (cycle: 1.6 ms)</p> <p>011: Clock $P\phi/512$ (cycle: 6.6 ms)</p> <p>100: Clock $P\phi/2048$ (cycle: 26.2 ms)</p> <p>101: Clock $P\phi/8192$ (cycle: 104.9 ms)</p> <p>110: Clock $P\phi/32768$ (cycle: 419.4 ms)</p> <p>111: Clock $P\phi/131072$ (cycle: 1.68 s)</p>

Note: * Only 0 can be written to this bit, to clear the flag.

16.3.3 Reset Control/Status Register (RSTCSR)

RSTCSR controls the generation of the internal reset signal when TCNT overflows, and selects the type of internal reset signal. RSTCSR is initialized to H'1F by a reset signal from the $\overline{\text{RES}}$ pin, but not by the WDT internal reset signal caused by WDT overflows.

Bit	7	6	5	4	3	2	1	0
Bit Name	WOVF	RSTE	—	—	—	—	—	—
Initial Value	0	0	0	1	1	1	1	1
R/W	R/(W)*	R/W	R/W	R	R	R	R	R

Note: * Only 0 can be written to this bit, to clear the flag.

Bit	Bit Name	Initial Value	R/W	Description
7	WOVF	0	R/(W)*	<p>Watchdog Timer Overflow Flag</p> <p>This bit is set when TCNT overflows in watchdog timer mode. This bit cannot be set in interval timer mode, and only 0 can be written.</p> <p>[Setting condition]</p> <p>When TCNT overflows (changed from H'FF to H'00) in watchdog timer mode</p> <p>[Clearing condition]</p> <p>Reading RSTCSR when WOVF = 1, and then writing 0 to WOVF</p>
6	RSTE	0	R/W	<p>Reset Enable</p> <p>Specifies whether or not this LSI is internally reset if TCNT overflows during watchdog timer operation.</p> <p>0: LSI is not reset even if TCNT overflows (Though this LSI is not reset, TCNT and TCSR in WDT are reset)</p> <p>1: LSI is reset if TCNT overflows</p>

Bit	Bit Name	Initial Value	R/W	Description
5	—	0	R/W	Reserved Although this bit is readable/writable, reading from or writing to this bit does not affect operation.
4 to 0	—	All 1	R	Reserved These are read-only bits and cannot be modified.

Note: * Only 0 can be written to this bit, to clear the flag.

16.4 Operation

16.4.1 Watchdog Timer Mode

To use the WDT in watchdog timer mode, set both the $\overline{WT/IT}$ and TME bits in TCSR to 1.

During watchdog timer operation, if TCNT overflows without being rewritten because of a system crash or other error, the \overline{WDTOVF} signal is output. This ensures that TCNT does not overflow while the system is operating normally. Software must prevent TCNT overflows by rewriting the TCNT value (normally H'00 is written) before overflow occurs. This \overline{WDTOVF} signal can be used to reset the LSI internally in watchdog timer mode.

If TCNT overflows when the RSTE bit in RSTCSR is set to 1, a signal that resets this LSI internally is generated at the same time as the \overline{WDTOVF} signal. If a reset caused by a signal input to the \overline{RES} pin occurs at the same time as a reset caused by a WDT overflow, the \overline{RES} pin reset has priority and the WOVF bit in RSTCSR is cleared to 0.

The \overline{WDTOVF} signal is output for 133 cycles of $P\phi$ when RSTE = 1 in RSTCSR, and for 130 cycles of $P\phi$ when RSTE = 0 in RSTCSR. The internal reset signal is output for 519 cycles of $P\phi$.

When RSTE = 1, an internal reset signal is generated. Since the system clock control register (SCKCR) is initialized, the multiplication ratio of $P\phi$ becomes the initial value.

When RSTE = 0, an internal reset signal is not generated. Neither SCKCR nor the multiplication ratio of $P\phi$ is changed.

When TCNT overflows in watchdog timer mode, the WOVF bit in RSTCSR is set to 1. If TCNT overflows when the RSTE bit in RSTCSR is set to 1, an internal reset signal is generated for the entire LSI.

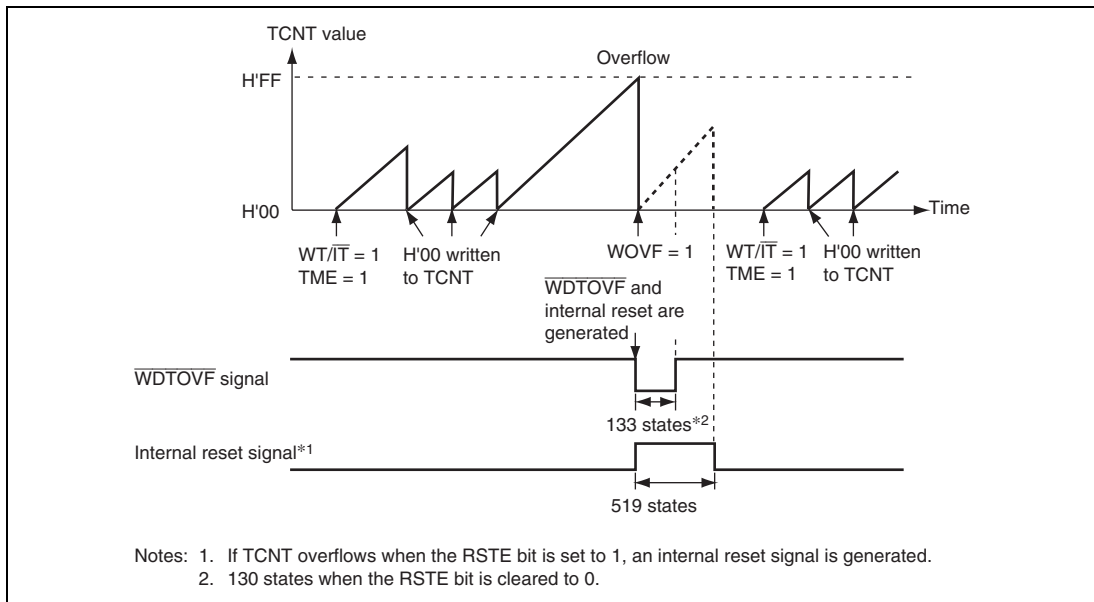

Figure 16.2 Operation in Watchdog Timer Mode

16.4.2 Interval Timer Mode

To use the WDT as an interval timer, set the $\overline{WT/IT}$ bit to 0 and the TME bit to 1 in TCSR.

When the WDT is used as an interval timer, an interval timer interrupt (WOVI) is generated each time the TCNT overflows. Therefore, an interrupt can be generated at intervals.

When the TCNT overflows in interval timer mode, an interval timer interrupt (WOVI) is requested at the same time the OVF bit in the TCSR is set to 1.

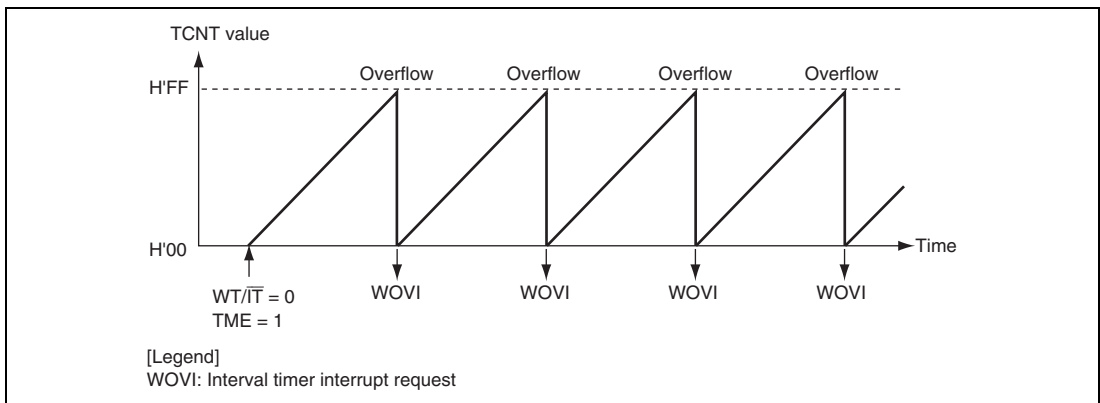

Figure 16.3 Operation in Interval Timer Mode

16.5 Interrupt Source

During interval timer mode operation, an overflow generates an interval timer interrupt (WOVI). The interval timer interrupt is requested whenever the OVF flag is set to 1 in TCSR. The OVF flag must be cleared to 0 in the interrupt handling routine.

Table 16.2 WDT Interrupt Source

Name	Interrupt Source	Interrupt Flag	DTC Activation
WOVI	TCNT overflow	OVF	Impossible

(2) Reading from TCNT, TCSR, and RSTCSR

These registers can be read from in the same way as other registers. For reading, TCSR is assigned to address H'FFA4, TCNT to address H'FFA5, and RSTCSR to address H'FFA7.

16.6.2 Conflict between Timer Counter (TCNT) Write and Increment

If a TCNT clock pulse is generated during the T2 cycle of a TCNT write cycle, the write takes priority and the timer counter is not incremented. Figure 16.5 shows this operation.

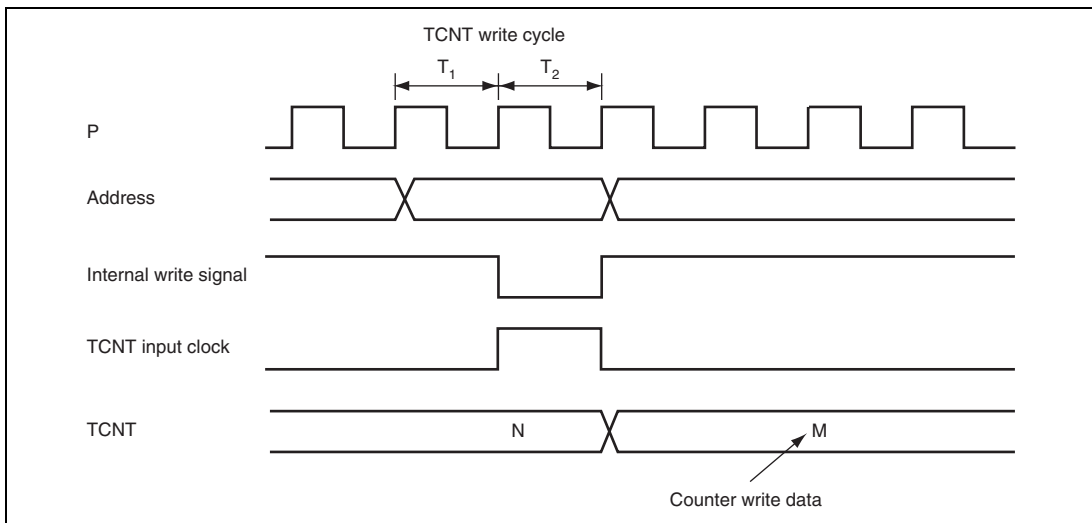

Figure 16.5 Conflict between TCNT Write and Increment

16.6.3 Changing Values of Bits CKS2 to CKS0

If bits CKS2 to CKS0 in TCSR are written to while the WDT is operating, errors could occur in the incrementation. The watchdog timer must be stopped (by clearing the TME bit to 0) before the values of bits CKS2 to CKS0 are changed.

16.6.4 Switching between Watchdog Timer Mode and Interval Timer Mode

If the timer mode is switched from watchdog timer mode to interval timer mode while the WDT is operating, errors could occur in the incrementation. The watchdog timer must be stopped (by clearing the TME bit to 0) before switching the timer mode.

16.6.5 Internal Reset in Watchdog Timer Mode

This LSI is not reset internally if TCNT overflows while the RSTE bit is cleared to 0 during watchdog timer mode operation, but TCNT and TCSR of the WDT are reset.

TCNT, TCSR, and RSTCR cannot be written to while the $\overline{\text{WDTOVF}}$ signal is low. Also note that a read of the WOVF flag is not recognized during this period. To clear the WOVF flag, therefore, read TCSR after the $\overline{\text{WDTOVF}}$ signal goes high, then write 0 to the WOVF flag.

16.6.6 System Reset by $\overline{\text{WDTOVF}}$ Signal

If the $\overline{\text{WDTOVF}}$ signal is input to the $\overline{\text{RES}}$ pin, this LSI will not be initialized correctly. Make sure that the $\overline{\text{WDTOVF}}$ signal is not input logically to the $\overline{\text{RES}}$ pin. To reset the entire system by means of the $\overline{\text{WDTOVF}}$ signal, use a circuit like that shown in Figure 16.6.

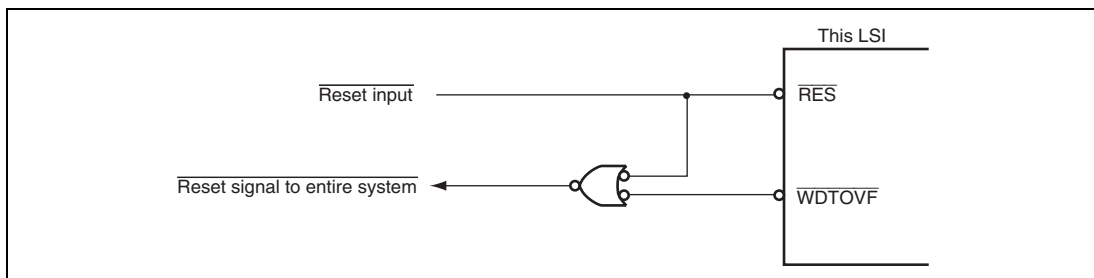

Figure 16.6 Circuit for System Reset by $\overline{\text{WDTOVF}}$ Signal (Example)

16.6.7 Transition to Watchdog Timer Mode or Software Standby Mode

When the WDT operates in watchdog timer mode, a transition to software standby mode is not made even when the SLEEP instruction is executed when the SSBY bit in SBYCR is set to 1. Instead, a transition to sleep mode is made.

To transit to software standby mode, the SLEEP instruction must be executed after halting the WDT (clearing the TME bit to 0).

When the WDT operates in interval timer mode, a transition to software standby mode is made through execution of the SLEEP instruction when the SSBY bit in SBYCR is set to 1.

Section 17 Serial Communication Interface (SCI, IrDA, CRC)

This LSI has seven independent serial communication interface (SCI) channels. The SCI can handle both asynchronous and clock synchronous serial communication. Asynchronous serial data communication can be carried out with standard asynchronous communication chips such as a Universal Asynchronous Receiver/Transmitter (UART) or Asynchronous Communication Interface Adapter (ACIA). A function is also provided for serial communication between processors (multiprocessor communication function). The SCI also supports the smart card (smart card) interface supporting ISO/IEC 7816-3 (Identification Card) as an extended asynchronous communication mode. SCI_5 enables transmitting and receiving IrDA communication waveform based on the IrDA Specifications version 1.0. This LSI incorporates the on-chip CRC (Cyclic Redundancy Check) computing unit that realizes high reliability of high-speed data transfer as SCI extended function. Since the CRC computing unit is not connected to SCI, operation is executed by writing data to registers.

Figure 17.1 shows a block diagram of the SCI_0 to SCI_4. Figure 17.2 shows a block diagram of the SCI_5 and SCI_6.

17.1 Features

- Choice of asynchronous or clock synchronous serial communication mode
- Full-duplex communication capability
The transmitter and receiver are mutually independent, enabling transmission and reception to be executed simultaneously. Double-buffering is used in both the transmitter and the receiver, enabling continuous transmission and continuous reception of serial data.
- On-chip baud rate generator allows any bit rate to be selected
The external clock can be selected as a transfer clock source (except for the smart card interface).
- Choice of LSB-first or MSB-first transfer (except in the case of asynchronous mode 7-bit data)
- Four interrupt sources
The interrupt sources are transmit-end, transmit-data-empty, receive-data-full, and receive error. The transmit-data-empty and receive-data-full interrupt sources can activate the DTC or DMAC.
- Module stop state specifiable

Asynchronous Mode:

- Data length: 7 or 8 bits
- Stop bit length: 1 or 2 bits
- Parity: Even, odd, or none
- Receive error detection: Parity, overrun, and framing errors
- Break detection: Break can be detected by reading the RxD pin level directly in case of a framing error
- Enables transfer rate clock input from TMR (SCI_5, SCI_6)
- Average transfer rate generator (SCI_2)
 - 10.667-MHz operation: 115.152 kbps or 460.606 kbps can be selected
 - 16-MHz operation: 115.196 kbps, 460.784 kbps, or 720 kbps can be selected
 - 32-MHz operation: 720 kbps
- Average transfer rate generator (SCI_5, SCI_6)
 - 8-MHz operation: 460.784 kbps can be selected
 - 10.667-MHz operation: 115.152 kbps or 460.606 kbps can be selected
 - 12-MHz operation: 230.263 kbps or 460.526 kbps can be selected
 - 16-MHz operation: 115.196 kbps, 460.784 kbps, 720 kbps, or 921.569 kbps can be selected
 - 24-MHz operation: 115.132 kbps, 460.526 kbps, 720 kbps, or 921.053 kbps can be selected
 - 32-MHz operation: 720 kbps can be selected

Clock Synchronous Mode:

- Data length: 8 bits
- Receive error detection: Overrun errors

Smart Card Interface:

- An error signal can be automatically transmitted on detection of a parity error during reception
- Data can be automatically re-transmitted on receiving an error signal during transmission
- Both direct convention and inverse convention are supported

Table 17.1 lists the functions of each channel.

Table 17.1 Function List of SCI Channels

		SCI_0, 1, 3, 4	SCI_2	SCI_5, SCI_6	
Clock synchronous mode		O	O	O	
Asynchronous mode		O	O	O	
TMR clock input		—	—	O	
When average transfer rate generator is used	$P\phi = 8$ Hz	—	—	460.784 kbps	
	$P\phi = 10.667$ Hz	—	460.606 kbps	460.606 kbps	
			115.152 kbps	115.152 kbps	
			—	—	
	$P\phi = 12$ Hz	—	—	460.526 kbps 230.263 kbps	
	$P\phi = 16$ Hz	—	—	720 kbps	921.569 kbps
				460.784 kbps	720 kbps
				115.196 kbps	460.784 kbps 115.196 kbps
				—	—
	$P\phi = 24$ Hz	—	—	—	921.053 kbps 720 kbps 460.526 kbps 115.132 kbps
—				—	
—				—	
—				—	
$P\phi = 32$ Hz	—	—	720 kbps	720 kbps	

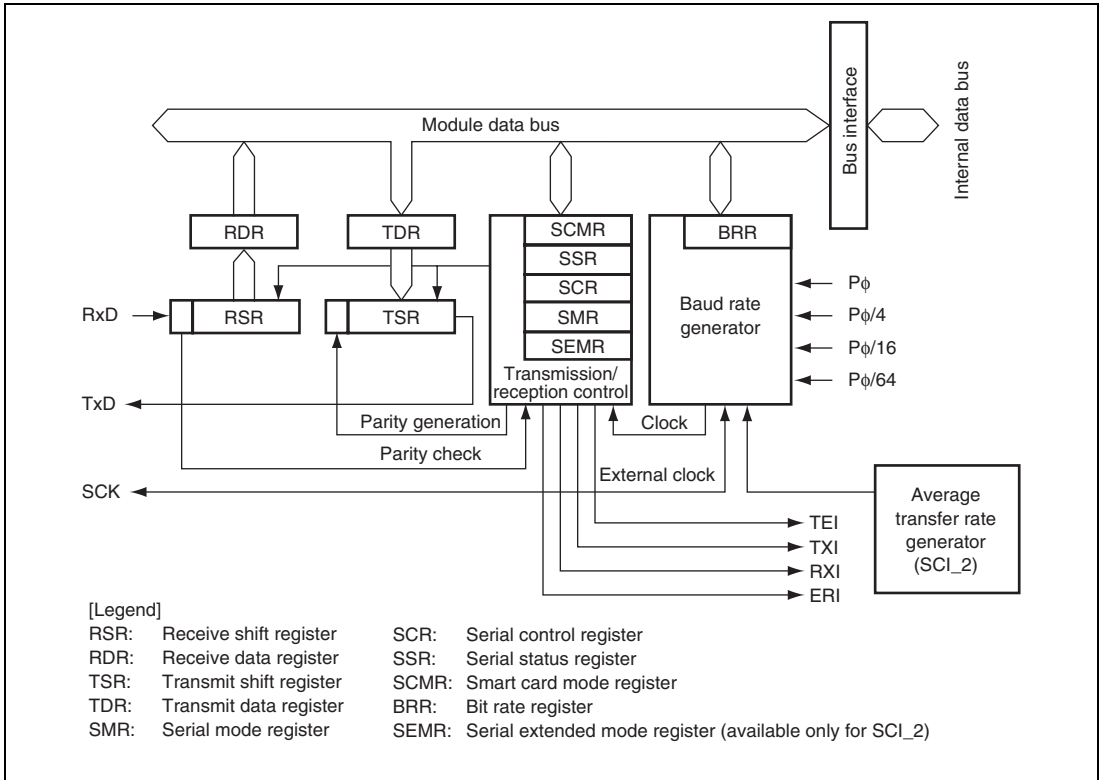

Figure 17.1 Block Diagram of SCI_0, 1, 2, 3, and 4

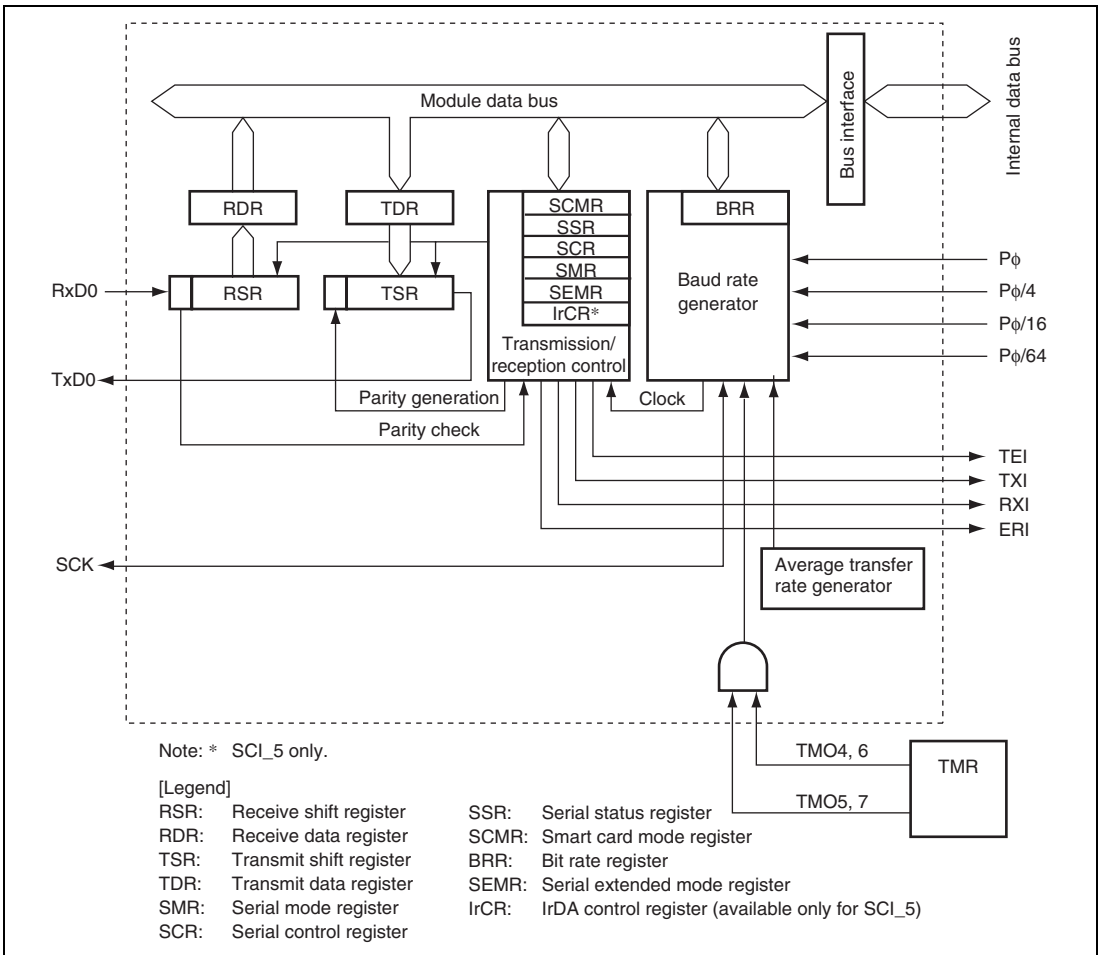

Figure 17.2 Block Diagram of SCI_5 and SCI_6

17.2 Input/Output Pins

Table 17.2 lists the pin configuration of the SCI.

Table 17.2 Pin Configuration

Channel	Pin Name*	I/O	Function
0	SCK0	I/O	Channel 0 clock input/output
	RxD0	Input	Channel 0 receive data input
	TxD0	Output	Channel 0 transmit data output
1	SCK1	I/O	Channel 1 clock input/output
	RxD1	Input	Channel 1 receive data input
	TxD1	Output	Channel 1 transmit data output
2	SCK2	I/O	Channel 2 clock input/output
	RxD2	Input	Channel 2 receive data input
	TxD2	Output	Channel 2 transmit data output
3	SCK3	I/O	Channel 3 clock input/output
	RxD3	Input	Channel 3 receive data input
	TxD3	Output	Channel 3 transmit data output
4	SCK4	I/O	Channel 4 clock input/output
	RxD4	Input	Channel 4 receive data input
	TxD4	Output	Channel 4 transmit data output
5	SCK5	I/O	Channel 5 clock input/output
	RxD5/IrRxD	Input	Channel 5 receive data input
	TxD5/IrTxD	Output	Channel 5 transmit data output
6	SCK6	I/O	Channel 6 clock input/output
	RxD6	Input	Channel 6 receive data input
	TxD6	Output	Channel 6 transmit data output

Note: * Pin names SCK, RxD, and TxD are used in the text for all channels, omitting the channel designation.

17.3 Register Descriptions

The SCI has the following registers. Some bits in the serial mode register (SMR), serial status register (SSR), and serial control register (SCR) have different functions in different modes—normal serial communication interface mode and smart card interface mode; therefore, the bits are described separately for each mode in the corresponding register sections.

Channel 0:

- Receive shift register_0 (RSR_0)
- Transmit shift register_0 (TSR_0)
- Receive data register_0 (RDR_0)
- Transmit data register_0 (TDR_0)
- Serial mode register_0 (SMR_0)
- Serial control register_0 (SCR_0)
- Serial status register_0 (SSR_0)
- Smart card mode register_0 (SCMR_0)
- Bit rate register_0 (BRR_0)

Channel 1:

- Receive shift register_1 (RSR_1)
- Transmit shift register_1 (TSR_1)
- Receive data register_1 (RDR_1)
- Transmit data register_1 (TDR_1)
- Serial mode register_1 (SMR_1)
- Serial control register_1 (SCR_1)
- Serial status register_1 (SSR_1)
- Smart card mode register_1 (SCMR_1)
- Bit rate register_1 (BRR_1)

Channel 2:

- Receive shift register_2 (RSR_2)
- Transmit shift register_2 (TSR_2)
- Receive data register_2 (RDR_2)
- Transmit data register_2 (TDR_2)
- Serial mode register_2 (SMR_2)
- Serial control register_2 (SCR_2)
- Serial status register_2 (SSR_2)
- Smart card mode register_2 (SCMR_2)
- Bit rate register_2 (BRR_2)

Channel 3:

- Receive shift register_3 (RSR_3)
- Transmit shift register_3 (TSR_3)
- Receive data register_3 (RDR_3)
- Transmit data register_3 (TDR_3)
- Serial mode register_3 (SMR_3)
- Serial control register_3 (SCR_3)
- Serial status register_3 (SSR_3)
- Smart card mode register_3 (SCMR_3)
- Bit rate register_3 (BRR_3)

Channel 4:

- Receive shift register_4 (RSR_4)
- Transmit shift register_4 (TSR_4)
- Receive data register_4 (RDR_4)
- Transmit data register_4 (TDR_4)
- Serial mode register_4 (SMR_4)
- Serial control register_4 (SCR_4)
- Serial status register_4 (SSR_4)
- Smart card mode register_4 (SCMR_4)
- Bit rate register_4 (BRR_4)

Channel 5:

- Receive shift register_5 (RSR_5)
- Transmit shift register_5 (TSR_5)
- Receive data register_5 (RDR_5)
- Transmit data register_5 (TDR_5)
- Serial mode register_5 (SMR_5)
- Serial control register_5 (SCR_5)
- Serial status register_5 (SSR_5)
- Smart card mode register_5 (SCMR_5)
- Bit rate register_5 (BRR_5)
- Serial extended mode register_5 (SEMR_5)
- IrDA control register_5 (IrCR)

Channel 6:

- Receive shift register_6 (RSR_6)
- Transmit shift register_6 (TSR_6)
- Receive data register_6 (RDR_6)
- Transmit data register_6 (TDR_6)
- Serial mode register_6 (SMR_6)
- Serial control register_6 (SCR_6)
- Serial status register_6 (SSR_6)
- Smart card mode register_6 (SCMR_6)
- Bit rate register_6 (BRR_6)
- Serial extended mode register_6 (SEMR_6)

17.3.1 Receive Shift Register (RSR)

RSR is a shift register which is used to receive serial data input from the RxD pin and converts it into parallel data. When one frame of data has been received, it is transferred to RDR automatically. RSR cannot be directly accessed by the CPU.

17.3.2 Receive Data Register (RDR)

RDR is an 8-bit register that stores receive data. When the SCI has received one frame of serial data, it transfers the received serial data from RSR to RDR where it is stored. This allows RSR to receive the next data. Since RSR and RDR function as a double buffer in this way, continuous receive operations can be performed. After confirming that the RDRF bit in SSR is set to 1, read RDR only once. RDR cannot be written to by the CPU.

Bit	7	6	5	4	3	2	1	0
Bit Name								
Initial Value	0	0	0	0	0	0	0	0
R/W	R	R	R	R	R	R	R	R

17.3.3 Transmit Data Register (TDR)

TDR is an 8-bit register that stores transmit data. When the SCI detects that TSR is empty, it transfers the transmit data written in TDR to TSR and starts transmission. The double-buffered structures of TDR and TSR enable continuous serial transmission. If the next transmit data has already been written to TDR when one frame of data is transmitted, the SCI transfers the written data to TSR to continue transmission. Although TDR can be read from or written to by the CPU at all times, to achieve reliable serial transmission, write transmit data to TDR for only once after confirming that the TDRE bit in SSR is set to 1.

Bit	7	6	5	4	3	2	1	0
Bit Name								
Initial Value	1	1	1	1	1	1	1	1
R/W	R/W	R/W	R/W	R/W	R/W	R/W	R/W	R/W

17.3.4 Transmit Shift Register (TSR)

TSR is a shift register that transmits serial data. To perform serial data transmission, the SCI first automatically transfers transmit data from TDR to TSR, and then sends the data to the TxD pin. TSR cannot be directly accessed by the CPU.

17.3.5 Serial Mode Register (SMR)

SMR is used to set the SCI's serial transfer format and select the baud rate generator clock source. Some bits in SMR have different functions in normal mode and smart card interface mode.

- When SMIF in SCMR = 0

Bit	7	6	5	4	3	2	1	0
Bit Name	C/ \bar{A}	CHR	PE	O/ \bar{E}	STOP	MP	CKS1	CKS0
Initial Value	0	0	0	0	0	0	0	0
R/W	R/W	R/W	R/W	R/W	R/W	R/W	R/W	R/W

- When SMIF in SCMR = 1

Bit	7	6	5	4	3	2	1	0
Bit Name	GM	BLK	PE	O/ \bar{E}	BCP1	BCP0	CKS1	CKS0
Initial Value	0	0	0	0	0	0	0	0
R/W	R/W	R/W	R/W	R/W	R/W	R/W	R/W	R/W

Bit Functions in Normal Serial Communication Interface Mode (When SMIF in SCMR = 0):

Bit	Bit Name	Initial Value	R/W	Description
7	C/ \bar{A}	0	R/W	Communication Mode 0: Asynchronous mode 1: Clock synchronous mode
6	CHR	0	R/W	Character Length (valid only in asynchronous mode) 0: Selects 8 bits as the data length. 1: Selects 7 bits as the data length. LSB-first is fixed and the MSB (bit 7) in TDR is not transmitted in transmission. In clock synchronous mode, a fixed data length of 8 bits is used.
5	PE	0	R/W	Parity Enable (valid only in asynchronous mode) When this bit is set to 1, the parity bit is added to transmit data before transmission, and the parity bit is checked in reception. For a multiprocessor format, parity bit addition and checking are not performed regardless of the PE bit setting.
4	O/ \bar{E}	0	R/W	Parity Mode (valid only when the PE bit is 1 in asynchronous mode) 0: Selects even parity. 1: Selects odd parity.
3	STOP	0	R/W	Stop Bit Length (valid only in asynchronous mode) Selects the stop bit length in transmission. 0: 1 stop bit 1: 2 stop bits In reception, only the first stop bit is checked. If the second stop bit is 0, it is treated as the start bit of the next transmit frame.
2	MP	0	R/W	Multiprocessor Mode (valid only in asynchronous mode) When this bit is set to 1, the multiprocessor function is enabled. The PE bit and O/ \bar{E} bit settings are invalid in multiprocessor mode.

Bit	Bit Name	Initial Value	R/W	Description
1	CKS1	0	R/W	Clock Select 1, 0
0	CKS0	0	R/W	<p>These bits select the clock source for the baud rate generator.</p> <p>00: Pϕ clock (n = 0)</p> <p>01: Pϕ/4 clock (n = 1)</p> <p>10: Pϕ/16 clock (n = 2)</p> <p>11: Pϕ/64 clock (n = 3)</p> <p>For the relation between the settings of these bits and the baud rate, see section 17.3.9, Bit Rate Register (BRR). n is the decimal display of the value of n in BRR (see section 17.3.9, Bit Rate Register (BRR)).</p>

Bit Functions in Smart Card Interface Mode (When SMIF in SCMR = 1):

Bit	Bit Name	Initial Value	R/W	Description
7	GM	0	R/W	<p>GSM Mode</p> <p>Setting this bit to 1 allows GSM mode operation. In GSM mode, the TEND set timing is put forward to 11.0 etu from the start and the clock output control function is appended. For details, see sections 17.7.6, Data Transmission (Except in Block Transfer Mode) and 17.7.8, Clock Output Control.</p>
6	BLK	0	R/W	<p>Setting this bit to 1 allows block transfer mode operation. For details, see section 17.7.3, Block Transfer Mode.</p>
5	PE	0	R/W	<p>Parity Enable (valid only in asynchronous mode)</p> <p>When this bit is set to 1, the parity bit is added to transmit data before transmission, and the parity bit is checked in reception. Set this bit to 1 in smart card interface mode.</p>
4	O \bar{E}	0	R/W	<p>Parity Mode (valid only when the PE bit is 1 in asynchronous mode)</p> <p>0: Selects even parity</p> <p>1: Selects odd parity</p> <p>For details on the usage of this bit in smart card interface mode, see section 17.7.2, Data Format (Except in Block Transfer Mode).</p>

Bit	Bit Name	Initial Value	R/W	Description
3	BCP1	0	R/W	Base clock Pulse 1, 0
2	BCP0	0	R/W	<p>These bits select the number of base clock cycles in a 1-bit data transfer time in smart card interface mode.</p> <p>00: 32 clock cycles (S = 32) 01: 64 clock cycles (S = 64) 10: 372 clock cycles (S = 372) 11: 256 clock cycles (S = 256)</p> <p>For details, see section 17.7.4, Receive Data Sampling Timing and Reception Margin. S is described in section 17.3.9, Bit Rate Register (BRR).</p>
1	CKS1	0	R/W	Clock Select 1, 0
0	CKS0	0	R/W	<p>These bits select the clock source for the baud rate generator.</p> <p>00: $P\phi$ clock (n = 0) 01: $P\phi/4$ clock (n = 1) 10: $P\phi/16$ clock (n = 2) 11: $P\phi/64$ clock (n = 3)</p> <p>For the relation between the settings of these bits and the baud rate, see section 17.3.9, Bit Rate Register (BRR). n is the decimal display of the value of n in BRR (see section 17.3.9, Bit Rate Register (BRR)).</p>

Note: etu (Elementary Time Unit): 1-bit transfer time

17.3.6 Serial Control Register (SCR)

SCR is a register that enables/disables the following SCI transfer operations and interrupt requests, and selects the transfer clock source. For details on interrupt requests, see section 17.9, Interrupt Sources. Some bits in SCR have different functions in normal mode and smart card interface mode.

- When SMIF in SCMR = 0

Bit	7	6	5	4	3	2	1	0
Bit Name	TIE	RIE	TE	RE	MPIE	TEIE	CKE1	CKE0
Initial Value	0	0	0	0	0	0	0	0
R/W	R/W	R/W	R/W	R/W	R/W	R/W	R/W	R/W

- When SMIF in SCMR = 1

Bit	7	6	5	4	3	2	1	0
Bit Name	TIE	RIE	TE	RE	MPIE	TEIE	CKE1	CKE0
Initial Value	0	0	0	0	0	0	0	0
R/W	R/W	R/W	R/W	R/W	R/W	R/W	R/W	R/W

Bit Functions in Normal Serial Communication Interface Mode (When SMIF in SCMR = 0):

Bit	Bit Name	Initial Value	R/W	Description
7	TIE	0	R/W	<p>Transmit Interrupt Enable</p> <p>When this bit is set to 1, a TXI interrupt request is enabled.</p> <p>A TXI interrupt request can be cancelled by reading 1 from the TDRE flag and then clearing the flag to 0, or by clearing the TIE bit to 0.</p>
6	RIE	0	R/W	<p>Receive Interrupt Enable</p> <p>When this bit is set to 1, RXI and ERI interrupt requests are enabled.</p> <p>RXI and ERI interrupt requests can be cancelled by reading 1 from the RDRF, FER, PER, or ORER flag and then clearing the flag to 0, or by clearing the RIE bit to 0.</p>

Bit	Bit Name	Initial Value	R/W	Description
5	TE	0	R/W	<p>Transmit Enable</p> <p>When this bit is set to 1, transmission is enabled. Under this condition, serial transmission is started by writing transmit data to TDR, and clearing the TDRE flag in SSR to 0. Note that SMR should be set prior to setting the TE bit to 1 in order to designate the transmission format.</p> <p>If transmission is halted by clearing this bit to 0, the TDRE flag in SSR is fixed to 1.</p>
4	RE	0	R/W	<p>Receive Enable</p> <p>When this bit is set to 1, reception is enabled. Under this condition, serial reception is started by detecting the start bit in asynchronous mode or the synchronous clock input in clock synchronous mode. Note that SMR should be set prior to setting the RE bit to 1 in order to designate the reception format.</p> <p>Even if reception is halted by clearing this bit to 0, the RDRF, FER, PER, and ORER flags are not affected and the previous value is retained.</p>
3	MPIE	0	R/W	<p>Multiprocessor Interrupt Enable (valid only when the MP bit in SMR is 1 in asynchronous mode)</p> <p>When this bit is set to 1, receive data in which the multiprocessor bit is 0 is skipped, and setting of the RDRF, FER, and ORER status flags in SSR is disabled. On receiving data in which the multiprocessor bit is 1, this bit is automatically cleared and normal reception is resumed. For details, see section 17.5, Multiprocessor Communication Function.</p> <p>When receive data including MPB = 0 in SSR is being received, transfer of the received data from RSR to RDR, detection of reception errors, and the settings of RDRF, FER, and ORER flags in SSR are not performed. When receive data including MPB = 1 is received, the MPB bit in SSR is set to 1, the MPIE bit is automatically cleared to 0, and RXI and ERI interrupt requests (in the case where the TIE and RIE bits in SCR are set to 1) and setting of the FER and ORER flags are enabled.</p>

Bit	Bit Name	Initial Value	R/W	Description
2	TEIE	0	R/W	<p>Transmit End Interrupt Enable</p> <p>When this bit is set to 1, a TEI interrupt request is enabled. A TEI interrupt request can be cancelled by reading 1 from the TDRE flag and then clearing the flag to 0 in order to clear the TEND flag to 0, or by clearing the TEIE bit to 0.</p>
1	CKE1	0	R/W	Clock Enable 1, 0 (for SCI_0, 1, 3, and 4)
0	CKE0	0	R/W	<p>These bits select the clock source and SCK pin function.</p> <ul style="list-style-type: none"> • Asynchronous mode <ul style="list-style-type: none"> 00: On-chip baud rate generator <ul style="list-style-type: none"> The SCK pin functions as I/O port. 01: On-chip baud rate generator <ul style="list-style-type: none"> The clock with the same frequency as the bit rate is output from the SCK pin. 1x: External clock <ul style="list-style-type: none"> The clock with a frequency 16 times the bit rate should be input from the SCK pin. • Clock synchronous mode <ul style="list-style-type: none"> 0x: Internal clock <ul style="list-style-type: none"> The SCK pin functions as the clock output pin. 1x: External clock <ul style="list-style-type: none"> The SCK pin functions as the clock input pin.

Bit	Bit Name	Initial Value	R/W	Description
1	CKE1	0	R/W	Clock Enable 1, 0 (for SCI_2)
0	CKE0	0	R/W	<p>These bits select the clock source and SCK pin function.</p> <ul style="list-style-type: none"> Asynchronous mode <p>00: On-chip baud rate generator The SCK pin functions as I/O port.</p> <p>01: On-chip baud rate generator The clock with the same frequency as the bit rate is output from the SCK pin.</p> <p>1x: External clock or average transfer rate generator When an external clock is used, the clock with a frequency 16 times the bit rate should be input from the SCK pin. When an average transfer rate generator is used.</p> <ul style="list-style-type: none"> Clock synchronous mode <p>0x: Internal clock The SCK pin functions as the clock output pin.</p> <p>1x: External clock The SCK pin functions as the clock input pin.</p>

Bit	Bit Name	Initial Value	R/W	Description
1	CKE1	0	R/W	Clock Enable 1, 0 (for SCI_5 and SCI_6)
0	CKE0	0	R/W	<p>These bits select the clock source and SCK pin function.</p> <ul style="list-style-type: none"> • Asynchronous mode <ul style="list-style-type: none"> 00: On-chip baud rate generator The SCK pin functions as I/O port. 01: On-chip baud rate generator The clock with the same frequency as the bit rate is output from the SCK pin. 1x: External clock, TMR clock input or average transfer rate generator When an external clock is used, the clock with a frequency 16 times the bit rate should be input from the SCK pin. When an average transfer rate generator is used. When TMR clock input is used. • Clock synchronous mode <ul style="list-style-type: none"> 0x: Internal clock The SCK pin functions as the clock output pin. 1x: External clock The SCK pin functions as the clock input pin.

[Legend]

x: Don't care

Bit Functions in Smart Card Interface Mode (When SMIF in SCMR = 1):

Bit	Bit Name	Initial Value	R/W	Description
7	TIE	0	R/W	<p>Transmit Interrupt Enable</p> <p>When this bit is set to 1, a TXI interrupt request is enabled.</p> <p>A TXI interrupt request can be cancelled by reading 1 from the TDRE flag and then clearing the flag to 0, or by clearing the TIE bit to 0.</p>
6	RIE	0	R/W	<p>Receive Interrupt Enable</p> <p>When this bit is set to 1, RXI and ERI interrupt requests are enabled.</p> <p>RXI and ERI interrupt requests can be cancelled by reading 1 from the RDRF, FER, PER, or ORER flag and then clearing the flag to 0, or by clearing the RIE bit to 0.</p>
5	TE	0	R/W	<p>Transmit Enable</p> <p>When this bit is set to 1, transmission is enabled. Under this condition, serial transmission is started by writing transmit data to TDR, and clearing the TDRE flag in SSR to 0. Note that SMR should be set prior to setting the TE bit to 1 in order to designate the transmission format.</p> <p>If transmission is halted by clearing this bit to 0, the TDRE flag in SSR is fixed 1.</p>
4	RE	0	R/W	<p>Receive Enable</p> <p>When this bit is set to 1, reception is enabled. Under this condition, serial reception is started by detecting the start bit in asynchronous mode or the synchronous clock input in clock synchronous mode. Note that SMR should be set prior to setting the RE bit to 1 in order to designate the reception format.</p> <p>Even if reception is halted by clearing this bit to 0, the RDRF, FER, PER, and ORER flags are not affected and the previous value is retained.</p>
3	MPIE	0	R/W	<p>Multiprocessor Interrupt Enable (valid only when the MP bit in SMR is 1 in asynchronous mode)</p> <p>Write 0 to this bit in smart card interface mode.</p>
2	TEIE	0	R/W	<p>Transmit End Interrupt Enable</p> <p>Write 0 to this bit in smart card interface mode.</p>

Bit	Bit Name	Initial Value	R/W	Description
1	CKE1	0	R/W	Clock Enable 1, 0
0	CKE0	0	R/W	<p>These bits control the clock output from the SCK pin. In GSM mode, clock output can be dynamically switched. For details, see section 17.7.8, Clock Output Control.</p> <ul style="list-style-type: none"> When GM in SMR = 0 <ul style="list-style-type: none"> 00: Output disabled (SCK pin functions as I/O port.) 01: Clock output 1x: Reserved When GM in SMR = 1 <ul style="list-style-type: none"> 00: Output fixed low 01: Clock output 10: Output fixed high 11: Clock output

17.3.7 Serial Status Register (SSR)

SSR is a register containing status flags of the SCI and multiprocessor bits for transfer. TDRE, RDRF, ORER, PER, and FER can only be cleared. Some bits in SSR have different functions in normal mode and smart card interface mode.

- When SMIF in SCMR = 0

Bit	7	6	5	4	3	2	1	0
Bit Name	TDRE	RDRF	ORER	FER	PER	TEND	MPB	MPBT
Initial Value	1	0	0	R/(W)*	0	1	0	0
R/W	R/(W)*	R/(W)*	R/(W)*		R/(W)*	R	R	R/W

Note: * Only 0 can be written, to clear the flag.

- When SMIF in SCMR = 1

Bit	7	6	5	4	3	2	1	0
Bit Name	TDRE	RDRF	ORER	ERS	PER	TEND	MPB	MPBT
Initial Value	1	0	0	0	0	1	0	0
R/W	R/(W)*	R/(W)*	R/(W)*	R/(W)*	R/(W)*	R	R	R/W

Note: * Only 0 can be written, to clear the flag.

Bit Functions in Normal Serial Communication Interface Mode (When SMIF in SCMR = 0):

Bit	Bit Name	Initial Value	R/W	Description
7	TDRE	1	R/(W)*	<p>Transmit Data Register Empty</p> <p>Indicates whether TDR contains transmit data.</p> <p>[Setting conditions]</p> <ul style="list-style-type: none"> • When the TE bit in SCR is 0 • When data is transferred from TDR to TSR <p>[Clearing conditions]</p> <ul style="list-style-type: none"> • When 0 is written to TDRE after reading TDRE = 1 (When the CPU is used to clear this flag by writing 0 while the corresponding interrupt is enabled, be sure to read the flag after writing 0 to it.) • When a TXI interrupt request is issued allowing DMAC or DTC to write data to TDR
6	RDRF	0	R/(W)*	<p>Receive Data Register Full</p> <p>Indicates whether receive data is stored in RDR.</p> <p>[Setting condition]</p> <ul style="list-style-type: none"> • When serial reception ends normally and receive data is transferred from RSR to RDR <p>[Clearing conditions]</p> <ul style="list-style-type: none"> • When 0 is written to RDRF after reading RDRF = 1 (When the CPU is used to clear this flag by writing 0 while the corresponding interrupt is enabled, be sure to read the flag after writing 0 to it.) • When an RXI interrupt request is issued allowing DMAC or DTC to read data from RDR <p>The RDRF flag is not affected and retains its previous value when the RE bit in SCR is cleared to 0.</p> <p>Note that when the next serial reception is completed while the RDRF flag is being set to 1, an overrun error occurs and the received data is lost.</p>

Bit	Bit Name	Initial Value	R/W	Description
5	ORER	0	R/(W)*	<p>Overrun Error</p> <p>Indicates that an overrun error has occurred during reception and the reception ends abnormally.</p> <p>[Setting condition]</p> <ul style="list-style-type: none"> When the next serial reception is completed while RDRF = 1 In RDR, receive data prior to an overrun error occurrence is retained, but data received after the overrun error occurrence is lost. When the ORER flag is set to 1, subsequent serial reception cannot be performed. Note that, in clock synchronous mode, serial transmission also cannot continue. <p>[Clearing condition]</p> <ul style="list-style-type: none"> When 0 is written to ORER after reading ORER = 1 (When the CPU is used to clear this flag by writing 0 while the corresponding interrupt is enabled, be sure to read the flag after writing 0 to it.) Even when the RE bit in SCR is cleared, the ORER flag is not affected and retains its previous value.
4	FER	0	R/(W)*	<p>Framing Error</p> <p>Indicates that a framing error has occurred during reception in asynchronous mode and the reception ends abnormally.</p> <p>[Setting condition]</p> <ul style="list-style-type: none"> When the stop bit is 0 In 2-stop-bit mode, only the first stop bit is checked whether it is 1 but the second stop bit is not checked. Note that receive data when the framing error occurs is transferred to RDR, however, the RDRF flag is not set. In addition, when the FER flag is being set to 1, the subsequent serial reception cannot be performed. In clock synchronous mode, serial transmission also cannot continue. <p>[Clearing condition]</p> <ul style="list-style-type: none"> When 0 is written to FER after reading FER = 1 (When the CPU is used to clear this flag by writing 0 while the corresponding interrupt is enabled, be sure to read the flag after writing 0 to it.) Even when the RE bit in SCR is cleared, the FER flag is not affected and retains its previous value.

Bit	Bit Name	Initial Value	R/W	Description
3	PER	0	R/(W)*	<p>Parity Error</p> <p>Indicates that a parity error has occurred during reception in asynchronous mode and the reception ends abnormally.</p> <p>[Setting condition]</p> <ul style="list-style-type: none"> When a parity error is detected during reception Receive data when the parity error occurs is transferred to RDR, however, the RDRF flag is not set. Note that when the PER flag is being set to 1, the subsequent serial reception cannot be performed. In clock synchronous mode, serial transmission also cannot continue. <p>[Clearing condition]</p> <ul style="list-style-type: none"> When 0 is written to PER after reading PER = 1 (When the CPU is used to clear this flag by writing 0 while the corresponding interrupt is enabled, be sure to read the flag after writing 0 to it.) Even when the RE bit in SCR is cleared, the PER bit is not affected and retains its previous value.
2	TEND	1	R	<p>Transmit End</p> <p>[Setting conditions]</p> <ul style="list-style-type: none"> When the TE bit in SCR is 0 When TDRE = 1 at transmission of the last bit of a transmit character <p>[Clearing conditions]</p> <ul style="list-style-type: none"> When 0 is written to TDRE after reading TDRE = 1 When a TXI interrupt request is issued allowing DMAC or DTC to write data to TDR
1	MPB	0	R	<p>Multiprocessor Bit</p> <p>Stores the multiprocessor bit value in the receive frame. When the RE bit in SCR is cleared to 0 its previous state is retained.</p>
0	MPBT	0	R/W	<p>Multiprocessor Bit Transfer</p> <p>Sets the multiprocessor bit value to be added to the transmit frame.</p>

Note: * Only 0 can be written, to clear the flag.

Bit Functions in Smart Card Interface Mode (When SMIF in SCMR = 1):

Bit	Bit Name	Initial Value	R/W	Description
7	TDRE	1	R/(W)*	<p>Transmit Data Register Empty</p> <p>Indicates whether TDR contains transmit data.</p> <p>[Setting conditions]</p> <ul style="list-style-type: none"> • When the TE bit in SCR is 0 • When data is transferred from TDR to TSR <p>[Clearing conditions]</p> <ul style="list-style-type: none"> • When 0 is written to TDRE after reading TDRE = 1 (When the CPU is used to clear this flag by writing 0 while the corresponding interrupt is enabled, be sure to read the flag after writing 0 to it.) • When a TXI interrupt request is issued allowing DMAC or DTC to write data to TDR
6	RDRF	0	R/(W)*	<p>Receive Data Register Full</p> <p>Indicates whether receive data is stored in RDR.</p> <p>[Setting condition]</p> <ul style="list-style-type: none"> • When serial reception ends normally and receive data is transferred from RSR to RDR <p>[Clearing conditions]</p> <ul style="list-style-type: none"> • When 0 is written to RDRF after reading RDRF = 1 (When the CPU is used to clear this flag by writing 0 while the corresponding interrupt is enabled, be sure to read the flag after writing 0 to it.) • When an RXI interrupt request is issued allowing DMAC or DTC to read data from RDR <p>The RDRF flag is not affected and retains its previous value even when the RE bit in SCR is cleared to 0.</p> <p>Note that when the next reception is completed while the RDRF flag is being set to 1, an overrun error occurs and the received data is lost.</p>

Bit	Bit Name	Initial Value	R/W	Description
5	ORER	0	R/(W)*	<p>Overrun Error</p> <p>Indicates that an overrun error has occurred during reception and the reception ends abnormally.</p> <p>[Setting condition]</p> <ul style="list-style-type: none"> When the next serial reception is completed while RDRF = 1 <p>In RDR, the receive data prior to an overrun error occurrence is retained, but data received following the overrun error occurrence is lost. When the ORER flag is set to 1, subsequent serial reception cannot be performed. Note that, in clock synchronous mode, serial transmission also cannot continue.</p> <p>[Clearing condition]</p> <ul style="list-style-type: none"> When 0 is written to ORER after reading ORER = 1 (When the CPU is used to clear this flag by writing 0 while the corresponding interrupt is enabled, be sure to read the flag after writing 0 to it.) <p>Even when the RE bit in SCR is cleared, the ORER flag is not affected and retains its previous value.</p>
4	ERS	0	R/(W)*	<p>Error Signal Status</p> <p>[Setting condition]</p> <ul style="list-style-type: none"> When a low error signal is sampled <p>[Clearing condition]</p> <ul style="list-style-type: none"> When 0 is written to ERS after reading ERS = 1

Bit	Bit Name	Initial Value	R/W	Description
3	PER	0	R/(W)*	<p>Parity Error</p> <p>Indicates that a parity error has occurred during reception in asynchronous mode and the reception ends abnormally.</p> <p>[Setting condition]</p> <ul style="list-style-type: none">When a parity error is detected during reception Receive data when the parity error occurs is transferred to RDR, however, the RDRF flag is not set. Note that when the PER flag is being set to 1, the subsequent serial reception cannot be performed. In clock synchronous mode, serial transmission also cannot continue. <p>[Clearing condition]</p> <ul style="list-style-type: none">When 0 is written to PER after reading PER = 1 (When the CPU is used to clear this flag by writing 0 while the corresponding interrupt is enabled, be sure to read the flag after writing 0 to it.) Even when the RE bit in SCR is cleared, the PER flag is not affected and retains its previous value.

Bit	Bit Name	Initial Value	R/W	Description
2	TEND	1	R	<p>Transmit End</p> <p>This bit is set to 1 when no error signal is sent from the receiving side and the next transmit data is ready to be transferred to TDR.</p> <p>[Setting conditions]</p> <ul style="list-style-type: none"> • When both the TE and ERS bits in SCR are 0 • When ERS = 0 and TDRE = 1 after a specified time passed after completion of 1-byte data transfer. The set timing depends on the register setting as follows: When GM = 0 and BLK = 0, 2.5 etu after transmission start When GM = 0 and BLK = 1, 1.5 etu after transmission start When GM = 1 and BLK = 0, 1.0 etu after transmission start When GM = 1 and BLK = 1, 1.0 etu after transmission start <p>[Clearing conditions]</p> <ul style="list-style-type: none"> • When 0 is written to TEND after reading TEND = 1 • When a TXI interrupt request is issued allowing DMAC or DTC to write the next data to TDR
1	MPB	0	R	<p>Multiprocessor Bit</p> <p>Not used in smart card interface mode.</p>
0	MPBT	0	R/W	<p>Multiprocessor Bit Transfer</p> <p>Write 0 to this bit in smart card interface mode.</p>

Note: * Only 0 can be written, to clear the flag.

17.3.8 Smart Card Mode Register (SCMR)

SCMR selects smart card interface mode and its format.

Bit	7	6	5	4	3	2	1	0
Bit Name	—	—	—	—	SDIR	SINV	—	SMIF
Initial Value	1	1	1	1	0	0	1	0
R/W	—	—	—	—	R/W	R/W	—	R/W

Bit	Bit Name	Initial Value	R/W	Description
7 to 4	—	All 1	—	Reserved These bits are always read as 1.
3	SDIR	0	R/W	Smart Card Data Transfer Direction Selects the serial/parallel conversion format. 0: Transfer with LSB-first 1: Transfer with MSB-first This bit is valid only when the 8-bit data format is used for transmission/reception; when the 7-bit data format is used, data is always transmitted/received with LSB-first.
2	SINV	0	R/W	Smart Card Data Invert Inverts the transmit/receive data logic level. This bit does not affect the logic level of the parity bit. To invert the parity bit, invert the O/ \bar{E} bit in SMR. 0: TDR contents are transmitted as they are. Receive data is stored as it is in RDR. 1: TDR contents are inverted before being transmitted. Receive data is stored in inverted form in RDR.
1	—	1	—	Reserved This bit is always read as 1.
0	SMIF	0	R/W	Smart Card Interface Mode Select When this bit is set to 1, smart card interface mode is selected. 0: Normal asynchronous or clock synchronous mode 1: Smart card interface mode

17.3.9 Bit Rate Register (BRR)

BRR is an 8-bit register that adjusts the bit rate. As the SCI performs baud rate generator control independently for each channel, different bit rates can be set for each channel. Table 17.2 shows the relationships between the N setting in BRR and bit rate B for normal asynchronous mode and clock synchronous mode, and smart card interface mode. The initial value of BRR is H'FF, and it can be read from or written to by the CPU at all times.

Table 17.3 Relationships between N Setting in BRR and Bit Rate B

Mode	ABCS Bit	Bit Rate	Error
Asynchronous mode	0	$N = \frac{P\phi \times 10^6}{64 \times 2^{2n-1} \times B} - 1$	$\text{Error (\%)} = \left\{ \frac{P\phi \times 10^6}{B \times 64 \times 2^{2n-1} \times (N+1)} - 1 \right\} \times 100$
	1	$N = \frac{P\phi \times 10^6}{32 \times 2^{2n-1} \times B} - 1$	$\text{Error (\%)} = \left\{ \frac{P\phi \times 10^6}{B \times 32 \times 2^{2n-1} \times (N+1)} - 1 \right\} \times 100$
Clock synchronous mode		$N = \frac{P\phi \times 10^6}{8 \times 2^{2n-1} \times B} - 1$	
Smart card interface mode		$N = \frac{P\phi \times 10^6}{S \times 2^{2n+1} \times B} - 1$	$\text{Error (\%)} = \left\{ \frac{P\phi \times 10^6}{B \times S \times 2^{2n+1} \times (N+1)} - 1 \right\} \times 100$

[Legend]

B: Bit rate (bit/s)

N: BRR setting for baud rate generator ($0 \leq N \leq 255$)

P ϕ : Operating frequency (MHz)

n and S: Determined by the SMR settings shown in the following table.

SMR Setting			SMR Setting		
CKS1	CKS0	n	BCP1	BCP0	S
0	0	0	0	0	32
0	1	1	0	1	64
1	0	2	1	0	372
1	1	3	1	1	256

Table 17.4 shows sample N settings in BRR in normal asynchronous mode. Table 17.5 shows the maximum bit rate settable for each operating frequency. Tables 17.7 and 17.9 show sample N settings in BRR in clock synchronous mode and smart card interface mode, respectively. In smart card interface mode, the number of base clock cycles S in a 1-bit data transfer time can be selected. For details, see section 17.7.4, Receive Data Sampling Timing and Reception Margin. Tables 17.6 and 17.8 show the maximum bit rates with external clock input.

When the ABCS bit in the serial extended mode register_2, 5, and 6 (SEMR_2, 5, and 6) of SCI_2, 5, and 6 are set to 1 in asynchronous mode, the bit rate is two times that of shown in table 17.4.

Table 17.4 Examples of BRR Settings for Various Bit Rates (Asynchronous Mode) (1)

Bit Rate (bit/s)	Operating Frequency P ϕ (MHz)											
	8			9.8304			10			12		
	n	N	Error (%)	n	N	Error (%)	n	N	Error (%)	n	N	Error (%)
110	2	141	0.03	2	174	-0.26	2	177	-0.25	2	212	0.03
150	2	103	0.16	2	127	0.00	2	129	0.16	2	155	0.16
300	1	207	0.16	1	255	0.00	2	64	0.16	2	77	0.16
600	1	103	0.16	1	127	0.00	1	129	0.16	1	155	0.16
1200	0	207	0.16	0	255	0.00	1	64	0.16	1	77	0.16
2400	0	103	0.16	0	127	0.00	0	129	0.16	0	155	0.16
4800	0	51	0.16	0	63	0.00	0	64	0.16	0	77	0.16
9600	0	25	0.16	0	31	0.00	0	32	-1.36	0	38	0.16
19200	0	12	0.16	0	15	0.00	0	15	1.73	0	19	-2.34
31250	0	7	0.00	0	9	-1.70	0	9	0.00	0	11	0.00
38400	—	—	—	0	7	0.00	0	7	1.73	0	9	-2.34

Bit Rate (bit/s)	Operating Frequency P ϕ (MHz)											
	12.288			14			14.7456			16		
	n	N	Error (%)	n	N	Error (%)	n	N	Error (%)	n	N	Error (%)
110	2	217	0.08	2	248	-0.17	3	64	0.70	3	70	0.03
150	2	159	0.00	2	181	0.16	2	191	0.00	2	207	0.16
300	2	79	0.00	2	90	0.16	2	95	0.00	2	103	0.16
600	1	159	0.00	1	181	0.16	1	191	0.00	1	207	0.16
1200	1	79	0.00	1	90	0.16	1	95	0.00	1	103	0.16
2400	0	159	0.00	0	181	0.16	0	191	0.00	0	207	0.16
4800	0	79	0.00	0	90	0.16	0	95	0.00	0	103	0.16
9600	0	39	0.00	0	45	-0.93	0	47	0.00	0	51	0.16
19200	0	19	0.00	0	22	-0.93	0	23	0.00	0	25	0.16
31250	0	11	2.40	0	13	0.00	0	14	-1.70	0	15	0.00
38400	0	9	0.00	—	—	—	0	11	0.00	0	12	0.16

Note: In SCI_2, 5, and 6, this is an example when the ABCS bit in SEMR_2, 5, and 6 is 0.
When the ABCS bit is set to 1, the bit rate is two times.

Table 17.4 Examples of BRR Settings for Various Bit Rates (Asynchronous Mode) (2)

Bit Rate (bit/s)	Operating Frequency P ϕ (MHz)											
	17.2032			18			19.6608			20		
	n	N	Error (%)	n	N	Error (%)	n	N	Error (%)	n	N	Error (%)
110	3	75	0.48	3	79	-0.12	3	86	0.31	3	88	-0.25
150	2	223	0.00	2	233	0.16	2	255	0.00	3	64	0.16
300	2	111	0.00	2	116	0.16	2	127	0.00	2	129	0.16
600	1	223	0.00	1	233	0.16	1	255	0.00	2	64	0.16
1200	1	111	0.00	1	116	0.16	1	127	0.00	1	129	0.16
2400	0	223	0.00	0	233	0.16	0	255	0.00	1	64	0.16
4800	0	111	0.00	0	116	0.16	0	127	0.00	0	129	0.16
9600	0	55	0.00	0	58	-0.69	0	63	0.00	0	64	0.16
19200	0	27	0.00	0	28	1.02	0	31	0.00	0	32	-1.36
31250	0	16	1.20	0	17	0.00	0	19	-1.70	0	19	0.00
38400	0	13	0.00	0	14	-2.34	0	15	0.00	0	15	1.73

Operating Frequency $P\phi$ (MHz)

Bit Rate (bit/s)	25			30			33			35		
	n	N	Error (%)	n	N	Error (%)	n	N	Error (%)	n	N	Error (%)
110	3	110	-0.02	3	132	0.13	3	145	0.33	3	154	0.23
150	3	80	0.47	3	97	-0.35	3	106	0.39	3	113	-0.06
300	2	162	-0.15	2	194	0.16	2	214	-0.07	2	227	-0.06
600	2	80	0.47	2	97	-0.35	2	106	0.39	2	113	-0.06
1200	1	162	-0.15	1	194	0.16	1	214	-0.07	1	227	-0.06
2400	1	80	0.47	1	97	-0.35	1	106	0.39	1	113	-0.06
4800	0	162	-0.15	0	194	0.16	0	214	-0.07	0	227	-0.06
9600	0	80	0.47	0	97	-0.35	0	106	0.39	0	113	-0.06
19200	0	40	-0.76	0	48	-0.35	0	53	-0.54	0	56	-0.06
31250	0	24	0.00	0	29	0	0	32	0	0	34	0.00
38400	0	19	1.73	0	23	1.73	0	26	-0.54	0	27	1.73

Note: In SCI_2, 5, and 6, this is an example when the ABCS bit in SEMR_2, 5, and 6 is 0.
When the ABCS bit is set to 1, the bit rate is two times.

Table 17.5 Maximum Bit Rate for Each Operating Frequency (Asynchronous Mode)

$P\phi$ (MHz)	Maximum Bit Rate (bit/s)	n	N	$P\phi$ (MHz)	Maximum Bit Rate (bit/s)	n	N
8	250000	0	0	17.2032	537600	0	0
9.8304	307200	0	0	18	562500	0	0
10	312500	0	0	19.6608	614400	0	0
12	375000	0	0	20	625000	0	0
12.288	384000	0	0	25	781250	0	0
14	437500	0	0	30	937500	0	0
14.7456	460800	0	0	33	1031250	0	0
16	500000	0	0	35	1093750	0	0

Table 17.6 Maximum Bit Rate with External Clock Input (Asynchronous Mode)

$P\phi$ (MHz)	External Input Clock (MHz)	Maximum Bit Rate (bit/s)	$P\phi$ (MHz)	External Input Clock (MHz)	Maximum Bit Rate (bit/s)
8	2.0000	125000	17.2032	4.3008	268800
9.8304	2.4576	153600	18	4.5000	281250
10	2.5000	156250	19.6608	4.9152	307200
12	3.0000	187500	20	5.0000	312500
12.288	3.0720	192000	25	6.2500	390625
14	3.5000	218750	30	7.5000	468750
14.7456	3.6864	230400	33	8.2500	515625
16	4.0000	250000	35	8.7500	546875

Note: In SCI_2, this is an example when the ABCS bit in SEMR_2 is 0.

When the ABCS bit is set to 1, the bit rate is two times.

Table 17.7 BRR Settings for Various Bit Rates (Clock Synchronous Mode)

Bit Rate (bit/s)	Operating Frequency P ϕ (MHz)															
	8		10		16		20		25		30		33		35	
	n	N	n	N	n	N	n	N	n	N	n	N	n	N	n	N
110																
250	3	124	—	—	3	249										
500	2	249	—	—	3	124	—	—			3	233				
1k	2	124	—	—	2	249	—	—	3	97	3	116	3	128	3	136
2.5k	1	199	1	249	2	99	2	124	2	155	2	187	2	205	2	218
5k	1	99	1	124	1	199	1	249	2	77	2	93	2	102	2	108
10k	0	199	0	249	1	99	1	124	1	155	1	187	1	205	1	218
25k	0	79	0	99	0	159	0	199	0	249	1	74	1	82	1	87
50k	0	39	0	49	0	79	0	99	0	124	0	149	0	164	0	174
100k	0	19	0	24	0	39	0	49	0	62	0	74	0	82	0	87
250k	0	7	0	9	0	15	0	19	0	24	0	29	0	32	0	34
500k	0	3	0	4	0	7	0	9	—	—	0	14	—	—	—	—
1M	0	1			0	3	0	4	—	—	—	—	—	—	—	—
2.5M			0	0*			0	1	—	—	0	2	—	—	—	—
5M							0	0*	—	—	—	—	—	—	—	—

[Legend]

Space: Setting prohibited.

—: Can be set, but there will be error.

Notes: * Continuous transmission or reception is not possible.

Table 17.8 Maximum Bit Rate with External Clock Input (Clock Synchronous Mode)

$P\phi$ (MHz)	External Input Clock (MHz)	Maximum Bit Rate (bit/s)	$P\phi$ (MHz)	External Input Clock (MHz)	Maximum Bit Rate (bit/s)
8	1.3333	1333333.3	20	3.3333	3333333.3
10	1.6667	1666666.7	25	4.1667	4166666.7
12	2.0000	2000000.0	30	5.0000	5000000.0
14	2.3333	2333333.3	33	5.5000	5500000.0
16	2.6667	2666666.7	35	5.8336	5833625.0
18	3.0000	3000000.0			

Table 17.9 BRR Settings for Various Bit Rates
(Smart Card Interface Mode, $n = 0$, $S = 372$)

Bit Rate (bit/sec)	Operating Frequency $P\phi$ (MHz)											
	7.1424			10.00			10.7136			13.00		
	n	N	Error (%)	n	N	Error (%)	n	N	Error (%)	n	N	Error (%)
9600	0	0	0.00	0	1	30	0	1	25	0	1	8.99

Bit Rate (bit/sec)	Operating Frequency $P\phi$ (MHz)											
	14.2848			16.00			18.00			20.00		
	n	N	Error (%)	n	N	Error (%)	n	N	Error (%)	n	N	Error (%)
9600	0	1	0.00	0	1	12.01	0	2	15.99	0	2	6.66

Bit Rate (bit/sec)	Operating Frequency $P\phi$ (MHz)											
	25.00			30.00			33.00			35.00		
	n	N	Error (%)	n	N	Error (%)	n	N	Error (%)	n	N	Error (%)
9600	0	3	12.49	0	3	5.01	0	4	7.59	0	4	1.99

**Table 17.10 Maximum Bit Rate for Each Operating Frequency
(Smart Card Interface Mode, S = 372)**

$P\phi$ (MHz)	Maximum Bit Rate (bit/s)	n	N	$P\phi$ (MHz)	Maximum Bit Rate (bit/s)	n	N
7.1424	9600	0	0	18.00	24194	0	0
10.00	13441	0	0	20.00	26882	0	0
10.7136	14400	0	0	25.00	33602	0	0
13.00	17473	0	0	30.00	40323	0	0
14.2848	19200	0	0	33.00	44355	0	0
16.00	21505	0	0	35.00	47043	0	0

17.3.10 Serial Extended Mode Register (SEMR_2)

SEMR_2 selects the clock source in asynchronous mode of SCI_2. The base clock is automatically specified when the average transfer rate operation is selected.

Bit	7	6	5	4	3	2	1	0
Bit Name	—	—	—	—	ABCS	ACS2	ACS1	ACS0
Initial Value	Undefined	Undefined	Undefined	Undefined	0	0	0	0
R/W	R	R	R	R	R/W	R/W	R/W	R/W

Bit	Bit Name	Initial Value	R/W	Description
7 to 4	—	Undefined	R	Reserved These bits are always read as undefined and cannot be modified.
3	ABCS	0	R/W	Asynchronous Mode Base clock Select (valid only in asynchronous mode) Selects the base clock for a 1-bit period. 0: The base clock has a frequency 16 times the transfer rate 1: The base clock has a frequency 8 times the transfer rate

Bit	Bit Name	Initial Value	R/W	Description
2	ACS2	0	R/W	Asynchronous Mode Clock Source Select (valid when CKE1 = 1 in asynchronous mode)
1	ACS1	0	R/W	
0	ACS0	0	R/W	
				These bits select the clock source for the average transfer rate function. When the average transfer rate function is enabled, the base clock is automatically specified regardless of the ABCS bit value.
				0000: External clock input
				001: 115.152 kbps of average transfer rate specific to $P\phi = 10.667$ MHz is selected (operated using the base clock with a frequency 16 times the transfer rate)
				010: 460.606 kbps of average transfer rate specific to $P\phi = 10.667$ MHz is selected (operated using the base clock with a frequency 8 times the transfer rate)
				011: 720 kbps of average transfer rate specific to $P\phi = 32$ MHz is selected (operated using the base clock with a frequency 16 times the transfer rate)
				100: Setting prohibited
				101: 115.196 kbps of average transfer rate specific to $P\phi = 16$ MHz is selected (operated using the base clock with a frequency 16 times the transfer rate)
				110: 460.784 kbps of average transfer rate specific to $P\phi = 16$ MHz is selected (operated using the base clock with a frequency 16 times the transfer rate)
				111: 720 kbps of average transfer rate specific to $P\phi = 16$ MHz is selected (operated using the base clock with a frequency 8 times the transfer rate)
				The average transfer rate only supports operating frequencies of 10.667 MHz, 16 MHz, and 32 MHz.

17.3.11 Serial Extended Mode Register 5 and 6 (SEMR_5 and SEMR_6)

SEMR_5 and SEMR_6 select the clock source in asynchronous mode of SCI_5 and SCI_6. The base clock is automatically specified when the average transfer rate operation is selected. TMQ output in TMR unit 2 and unit 3 can also be set as the serial transfer base clock. Figure 17.3 describes the examples of base clock features when the average transfer rate operation is selected. Figure 17.4 describes the examples of base clock features when the TMO output in TMR is selected.

Bit	7	6	5	4	3	2	1	0
Bit Name	—	—	—	ABCS	ACS3	ACS2	ACS1	ACS0
Initial Value	Undefined	Undefined	Undefined	0	0	0	0	0
R/W	R	R	R	R/W	R/W	R/W	R/W	R/W

Bit	Bit Name	Initial Value	R/W	Description
7 to 5	—	Undefined	R	Reserved These bits are always read as undefined and cannot be modified.
4	ABCS	0	R/W	Asynchronous Mode Base Clock Select (valid only in asynchronous mode) Selects the base clock for a 1-bit period. 0: The base clock has a frequency 16 times the transfer rate 1: The base clock has a frequency 8 times the transfer rate
3	ACS3	0	R/W	Asynchronous Mode Clock Source Select
2	ACS2	0	R/W	These bits select the clock source for the average transfer rate function in the asynchronous mode. When the average transfer rate function is enabled, the base clock is automatically specified regardless of the ABCS bit value. The average transfer rate only corresponds to 8MHz, 10.667MHz, 12MHz, 16MHz, 24MHz, and 32MHz. No other clock is available. Setting of ACS3 to ACS0 must be done in the asynchronous mode (the C/A bit in SMR = 0) and the external clock input mode (the CKE bit SCR = 1). The setting examples are in Figures 17.3 and 17.4. (Each number in the four-digit number below corresponds to the value in the bits ACS3 to ACS0 from left to right respectively.)
1	ACS1	0	R/W	
0	ACS0	0	R/W	

Bit	Bit Name	Initial Value	R/W	Description									
3	ACS3	0	R/W	0000: External clock input									
2	ACS2	0	R/W	0001: 115.152 kbps of average transfer rate specific to $P\phi = 10.667$ MHz is selected (operated using the base clock with a frequency 16 times the transfer rate)									
1	ACS1	0	R/W										
0	ACSO	0	R/W	0010: 460.606 kbps of average transfer rate specific to $P\phi = 10.667$ MHz is selected (operated using the base clock with a frequency 8 times the transfer rate)									
				0011: 921.569 kbps of average transfer rate specific to $P\phi = 16$ MHz is selected or 460.784 kbps of average transfer rate specific to $P\phi = 8$ MHz is selected (operated using the base clock with a frequency 8 times the transfer rate)									
				0100: TMR clock input This setting allows the TMR compare match output to be used as the base clock. The table below shows the correspondence between the SCI channels and the compare match output.									
				<table border="1"> <thead> <tr> <th>SCI Channel</th> <th>TMR Unit</th> <th>Compare Match Output</th> </tr> </thead> <tbody> <tr> <td>SCI_5</td> <td>Unit 2</td> <td>TMO4, TMO5</td> </tr> <tr> <td>SCI_6</td> <td>Unit 3</td> <td>TMO6, TMO7</td> </tr> </tbody> </table>	SCI Channel	TMR Unit	Compare Match Output	SCI_5	Unit 2	TMO4, TMO5	SCI_6	Unit 3	TMO6, TMO7
SCI Channel	TMR Unit	Compare Match Output											
SCI_5	Unit 2	TMO4, TMO5											
SCI_6	Unit 3	TMO6, TMO7											
				0101: 115.196 kbps of average transfer rate specific to $P\phi = 16$ MHz is selected (operated using the base clock with a frequency 16 times the transfer rate)									
				0110: 460.784 kbps of average transfer rate specific to $P\phi = 16$ MHz is selected (operated using the base clock with a frequency 16 times the transfer rate)									
				0111: 720 kbps of average transfer rate specific to $P\phi = 16$ MHz is selected (operated using the base clock with a frequency 8 times the transfer rate)									

Bit	Bit Name	Initial Value	R/W	Description
3	ACS3	0	R/W	1000: 115.132 kbps of average transfer rate specific to $P\phi = 24$ MHz is selected (operated using the base clock with a frequency 16 times the transfer rate)
2	ACS2	0	R/W	
1	ACS1	0	R/W	1001: 460.526 kbps of average transfer rate specific to $P\phi = 24$ or MHz or 230.263 kbps of average transfer rate specific to $P\phi = 12$ MHz is selected (operated using the base clock with a frequency 16 times the transfer rate)
0	ACS0	0	R/W	1010: 720 kbps of average transfer rate specific to $P\phi = 24$ MHz is selected (operated using the base clock with a frequency 8 times the transfer rate)
				1011: 921.053 kbps of average transfer rate specific to $P\phi = 24$ or MHz or 460.526 kbps of average transfer rate specific to $P\phi = 12$ MHz is selected (operated using the base clock with a frequency 8 times the transfer rate)
				1100: 720 kbps of average transfer rate specific to $P\phi = 32$ MHz is selected (operated using the base clock with a frequency 16 times the transfer rate)
				1101: Reserved (setting prohibited)
				111x: Reserved (setting prohibited)

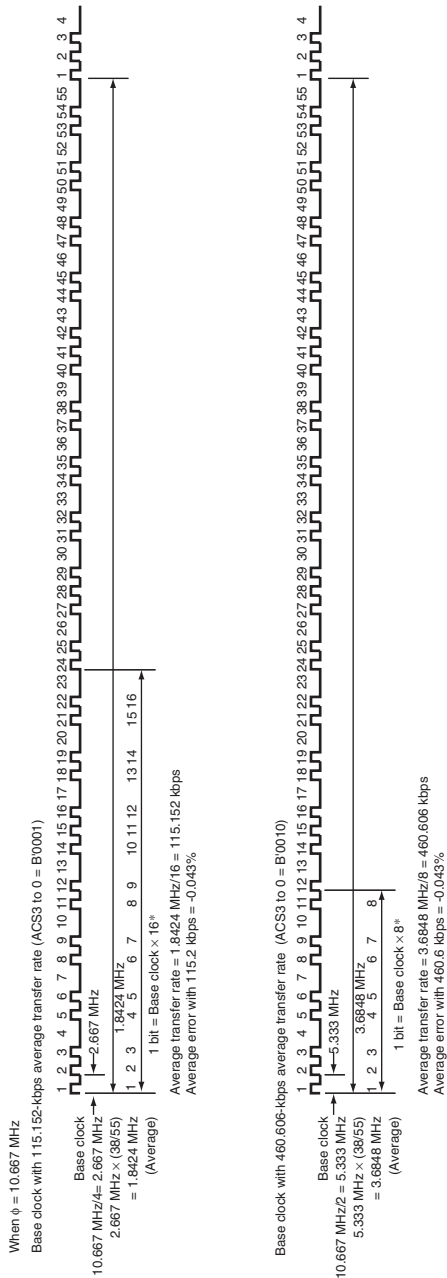

Note: * The length of one bit varies according to the base clock synchronization.

Figure 17.3 Examples of Base Clock when Average Transfer Rate is Selected (1)

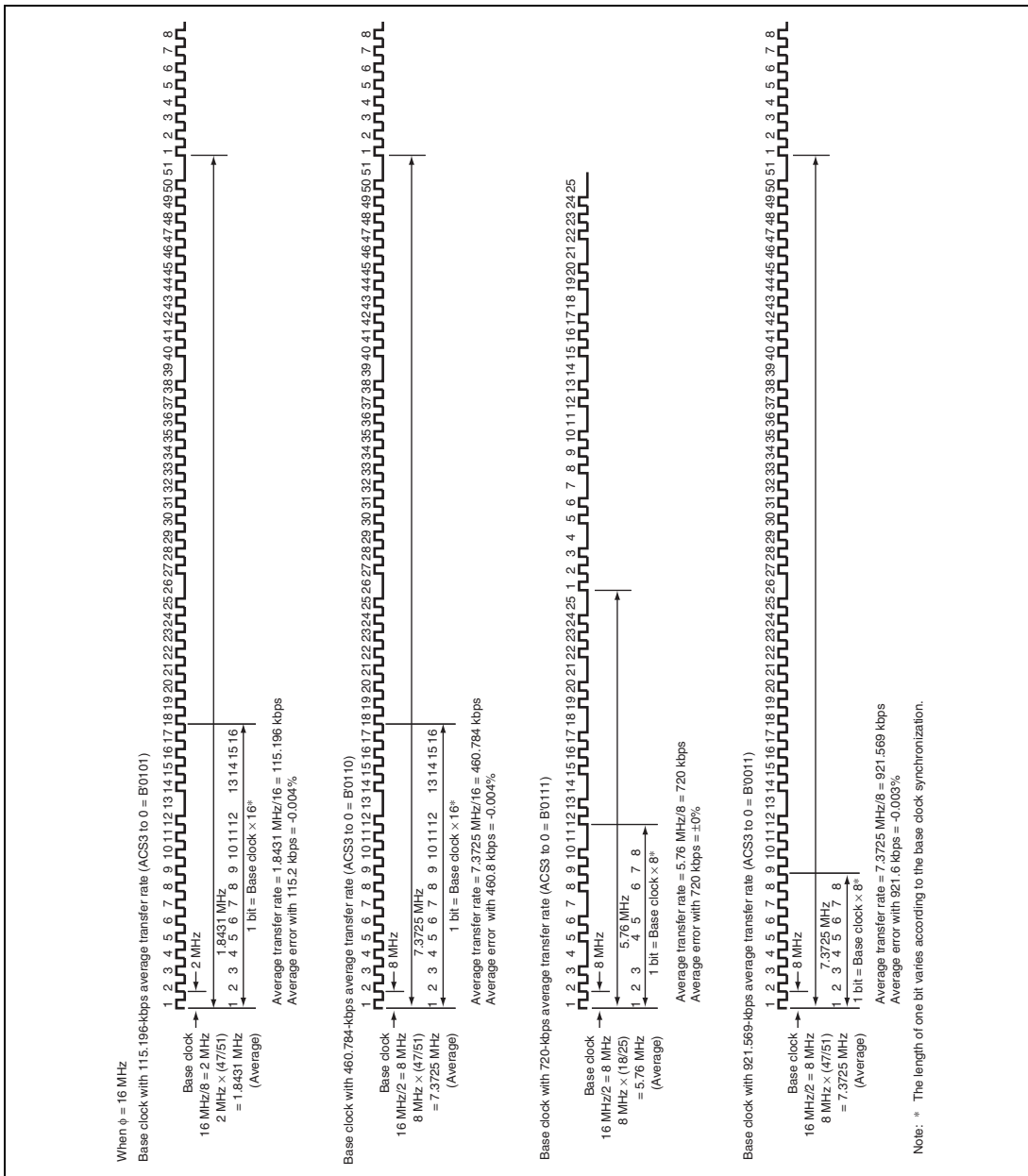

Figure 17.3 Examples of Base Clock when Average Transfer Rate is Selected (2)

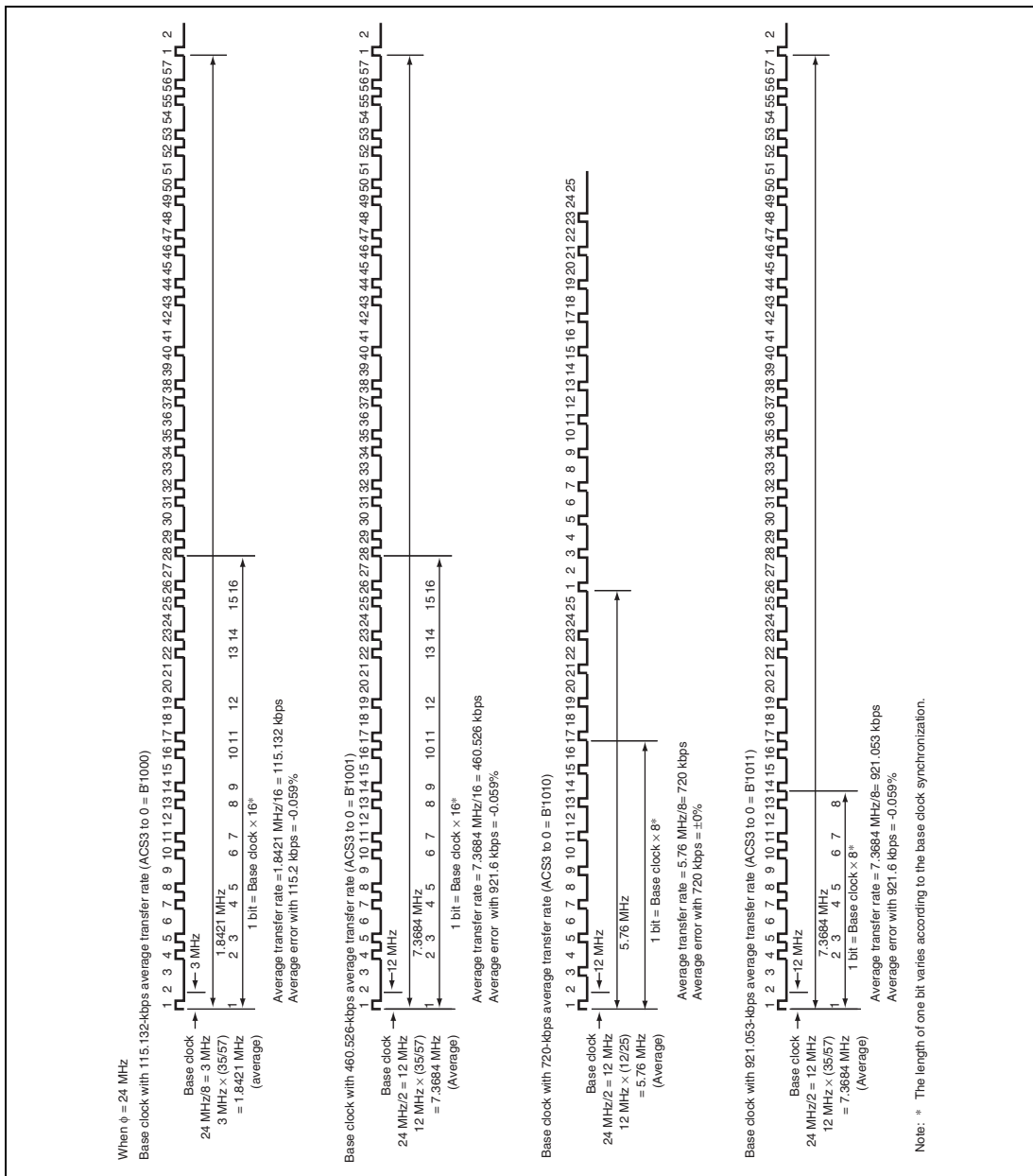

Figure 17.3 Examples of Base Clock when Average Transfer Rate is Selected (3)

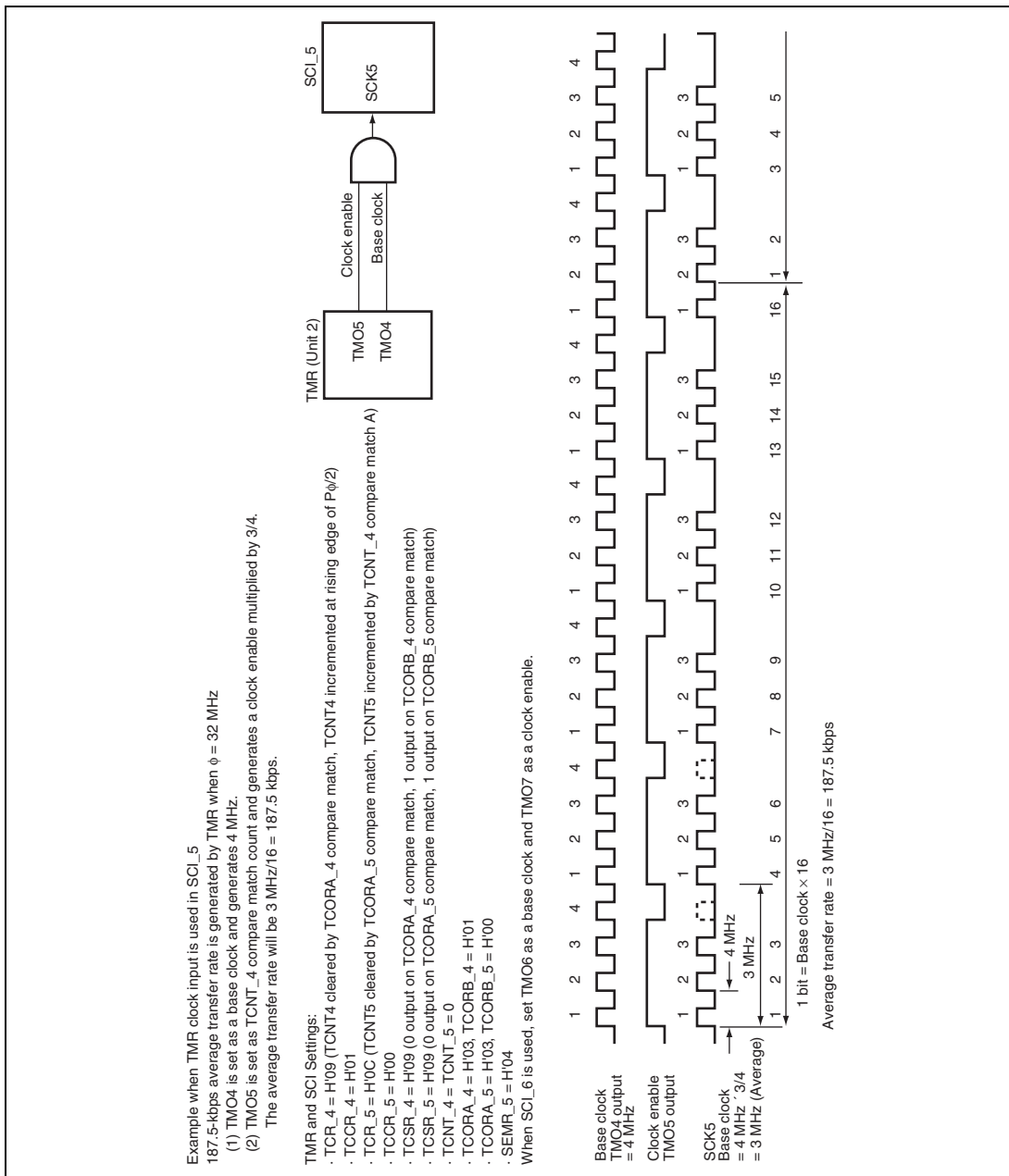

Figure 17.4 Example of Average Transfer Rate Setting when TMR Clock is Input

17.3.12 IrDA Control Register (IrCR)

IrCR selects the function of SCI_5.

Bit	7	6	5	4	3	2	1	0
Bit Name	IrE	IrCKS2	IrCKS1	IrCKS0	IrTxINV	IrRxINV	—	—
Initial Value	0	0	0	0	0	0	0	0
R/W	R/W	R/W	R/W	R/W	R/W	R/W	—	—

Bit	Bit Name	Initial Value	R/W	Description
7	IrE	0	R/W	IrDA Enable* Sets the SCI_5 I/O to normal SCI or IrDA. 0: TxD5/IrTxD and RxD5/IrRxD pins operate as TxD5 and RxD5. 1: TxD5/IrTxD and RxD5/IrRxD pins are operate as IrTxD and IrRxD.
6	IrCK2	0	R/W	IrDA Clock Select 2 to 0
5	IrCK1	0	R/W	Sets the pulse width of high state at encoding the IrTxD output pulse when the IrDA function is enabled.
4	IrCK0	0	R/W	000: Pulse-width = $B \times 3/16$ (Bit rate $\times 3/16$) 001: Pulse-width = $P\phi/2$ 010: Pulse-width = $P\phi/4$ 011: Pulse-width = $P\phi/8$ 100: Pulse-width = $P\phi/16$ 101: Pulse-width = $P\phi/32$ 110: Pulse-width = $P\phi/64$ 111: Pulse-width = $P\phi/128$
3	IrTxINV	0	R/W	IrTx Data Invert This bit specifies the inversion of the logic level in IrTxD output. When inversion is done, the pulse width of high state specified by the bits 6 to 4 becomes the pulse width in low state. 0: Outputs the transmission data as it is as IrTxD output 1: Outputs the inverted transmission data as IrTxD output

Bit	Bit Name	Initial Value	R/W	Description
2	IrRxINV	0	R/W	IrRx Data Invert This bit specifies the inversion of the logic level in IrRxD output. When inversion is done, the pulse width of high state specified by the bits 6 to 4 becomes the pulse width in low state. 0: Uses the IrRxD input data as it is as receive data. 1: Uses the inverted IrRxD input data as receive data.
1, 0	—	All 0	—	Reserved These bits are always read as 0. It should not be set to 0.

Note: * The IrDA function should be used when the ABCS bit in SEMR_5 is set to 0 and the ACS3 to ACS0 bits in SEMR_5 and SEMR_6 are set to B'0000.

17.4 Operation in Asynchronous Mode

Figure 17.5 shows the general format for asynchronous serial communication. One frame consists of a start bit (low level), transmit/receive data, a parity bit, and stop bits (high level). In asynchronous serial communication, the communication line is usually held in the mark state (high level). The SCI monitors the communication line, and when it goes to the space state (low level), recognizes a start bit and starts serial communication. Inside the SCI, the transmitter and receiver are independent units, enabling full-duplex communication. Both the transmitter and the receiver also have a double-buffered structure, so that data can be read or written during transmission or reception, enabling continuous data transmission and reception.

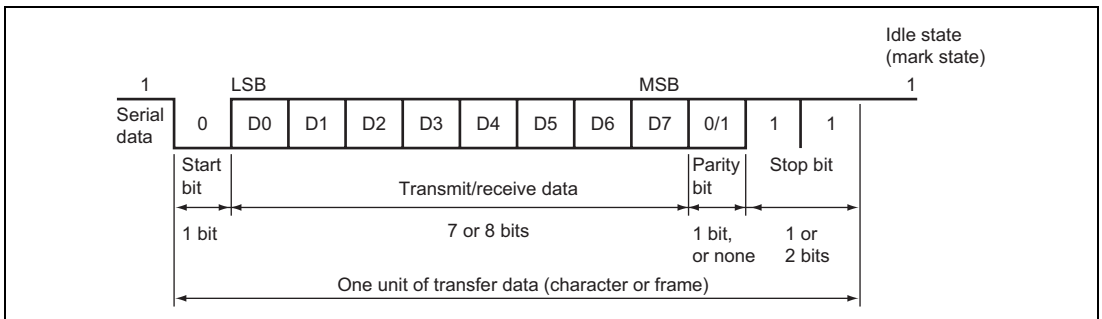

**Figure 17.5 Data Format in Asynchronous Communication
(Example with 8-Bit Data, Parity, Two Stop Bits)**

17.4.1 Data Transfer Format

Table 17.11 shows the data transfer formats that can be used in asynchronous mode. Any of 12 transfer formats can be selected according to the SMR setting. For details on the multiprocessor bit, see section 17.5, Multiprocessor Communication Function.

Table 17.11 Serial Transfer Formats (Asynchronous Mode)

SMR Settings				Serial Transfer Format and Frame Length													
CHR	PE	MP	STOP	1	2	3	4	5	6	7	8	9	10	11	12		
0	0	0	0	S	8-bit data								STOP				
0	0	0	1	S	8-bit data								STOP	STOP			
0	1	0	0	S	8-bit data								P	STOP			
0	1	0	1	S	8-bit data								P	STOP	STOP		
1	0	0	0	S	7-bit data							STOP					
1	0	0	1	S	7-bit data							STOP	STOP				
1	1	0	0	S	7-bit data							P	STOP				
1	1	0	1	S	7-bit data							P	STOP	STOP			
0	–	1	0	S	8-bit data								MPB	STOP			
0	–	1	1	S	8-bit data								MPB	STOP	STOP		
1	–	1	0	S	7-bit data							MPB	STOP				
1	–	1	1	S	7-bit data							MPB	STOP	STOP			

[Legend]

S: Start bit

STOP: Stop bit

P: Parity bit

MPB: Multiprocessor bit

17.4.2 Receive Data Sampling Timing and Reception Margin in Asynchronous Mode

In asynchronous mode, the SCI operates on a base clock with a frequency of 16 times* the bit rate. In reception, the SCI samples the falling edge of the start bit using the base clock, and performs internal synchronization. Since receive data is sampled at the rising edge of the 8th pulse* of the base clock, data is latched at the middle of each bit, as shown in Figure 17.6. Thus the reception margin in asynchronous mode is determined by formula (1) below.

$$M = \left| \left(0.5 - \frac{1}{2N} \right) - (L - 0.5) F - \frac{|D - 0.5|}{N} (1 + F) \right| \times 100 \quad [\%] \quad \cdots \text{Formula (1)}$$

[Legend]

M: Reception margin

N: Ratio of bit rate to clock (When ABCS = 0, N = 16. When ABCS = 1, N = 8.)

D: Duty cycle of clock (D = 0.5 to 1.0)

L: Frame length (L = 9 to 12)

F: Absolute value of clock frequency deviation

Assuming values of F = 0 and D = 0.5 in formula (1), the reception margin is determined by the formula below.

$$M = \left(0.5 - \frac{1}{2 \times 16} \right) \times 100 \quad [\%] = 46.875\%$$

However, this is only the computed value, and a margin of 20% to 30% should be allowed in system design.

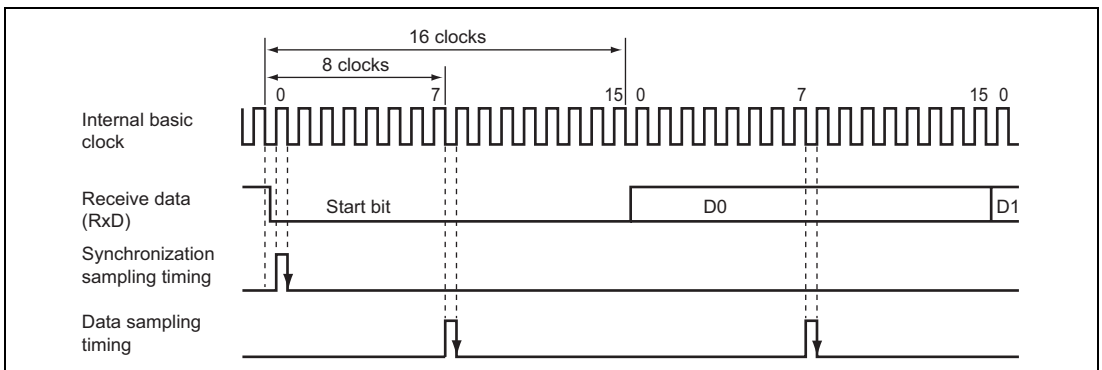

Figure 17.6 Receive Data Sampling Timing in Asynchronous Mode

Note: * This is an example when the ABCS bit in SEMR_2, 5, and 6 is 0. When the ABCS bit is 1, a frequency of 8 times the bit rate is used as a base clock and receive data is sampled at the rising edge of the 4th pulse of the base clock.

17.4.3 Clock

Either an internal clock generated by the on-chip baud rate generator or an external clock input to the SCK pin can be selected as the SCI's transfer clock, according to the setting of the C/\bar{A} bit in SMR and the CKE1 and CKE0 bits in SCR. When an external clock is input to the SCK pin, the clock frequency should be 16 times the bit rate (when ABCS = 0) and 8 times the bit rate (when ABCS = 1).

In addition, when an external clock is specified, the average transfer rate or the base clock of TMR_4 to TMR_7 can be selected by the ACS3 to ACS0 bits in SEMR_5 and SEMR_6.

When the SCI is operated on an internal clock, the clock can be output from the SCK pin. The frequency of the clock output in this case is equal to the bit rate, and the phase is such that the rising edge of the clock is in the middle of the transmit data, as shown in Figure 17.7.

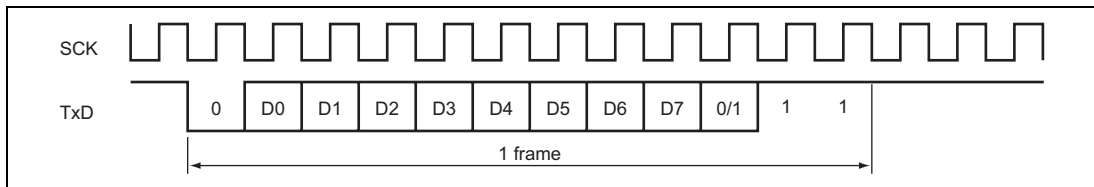

Figure 17.7 Phase Relation between Output Clock and Transmit Data (Asynchronous Mode)

17.4.4 SCI Initialization (Asynchronous Mode)

Before transmitting and receiving data, first clear the TE and RE bits in SCR to 0, then initialize the SCI as described in a sample flowchart in Figure 17.8. When the operating mode, transfer format, etc., is changed, the TE and RE bits must be cleared to 0 before making the change. When the TE bit is cleared to 0, the TDRE flag is set to 1. Note that clearing the RE bit to 0 does not initialize the RDRF, PER, FER, and ORER flags, or RDR. When the external clock is used in asynchronous mode, the clock must be supplied even during initialization.

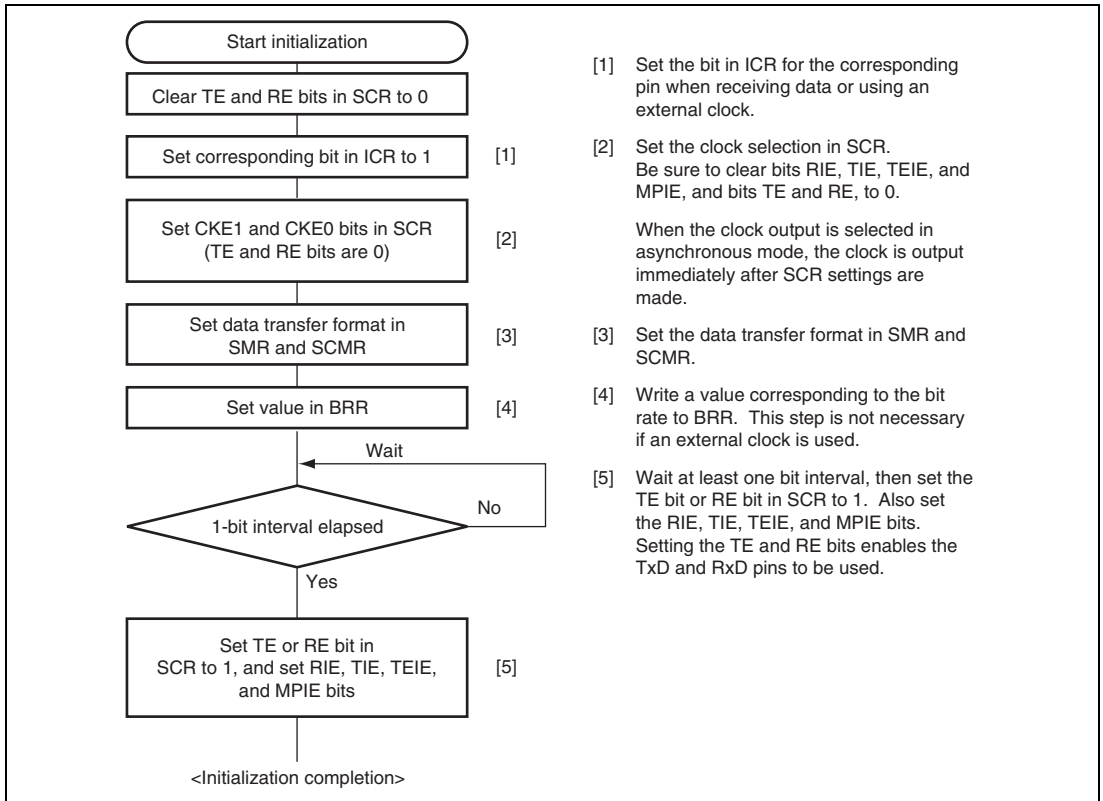

Figure 17.8 Sample SCI Initialization Flowchart

17.4.5 Serial Data Transmission (Asynchronous Mode)

Figure 17.9 shows an example of the operation for transmission in asynchronous mode. In transmission, the SCI operates as described below.

1. The SCI monitors the TDRE flag in SSR, and if it is cleared to 0, recognizes that data has been written to TDR, and transfers the data from TDR to TSR.
2. After transferring data from TDR to TSR, the SCI sets the TDRE flag to 1 and starts transmission. If the TIE bit in SCR is set to 1 at this time, a TXI interrupt request is generated. Because the TXI interrupt processing routine writes the next transmit data to TDR before transmission of the current transmit data has finished, continuous transmission can be enabled.
3. Data is sent from the TxD pin in the following order: start bit, transmit data, parity bit or multiprocessor bit (may be omitted depending on the format), and stop bit.
4. The SCI checks the TDRE flag at the timing for sending the stop bit.
5. If the TDRE flag is 0, the next transmit data is transferred from TDR to TSR, the stop bit is sent, and then serial transmission of the next frame is started.
6. If the TDRE flag is 1, the TEND flag in SSR is set to 1, the stop bit is sent, and then the mark state is entered in which 1 is output. If the TEIE bit in SCR is set to 1 at this time, a TEI interrupt request is generated.

Figure 17.10 shows a sample flowchart for transmission in asynchronous mode.

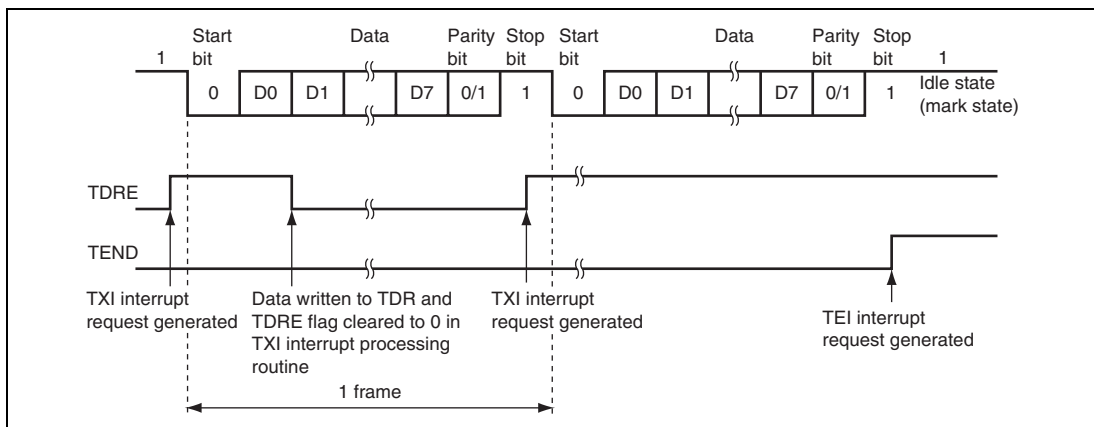

**Figure 17.9 Example of Operation for Transmission in Asynchronous Mode
(Example with 8-Bit Data, Parity, One Stop Bit)**

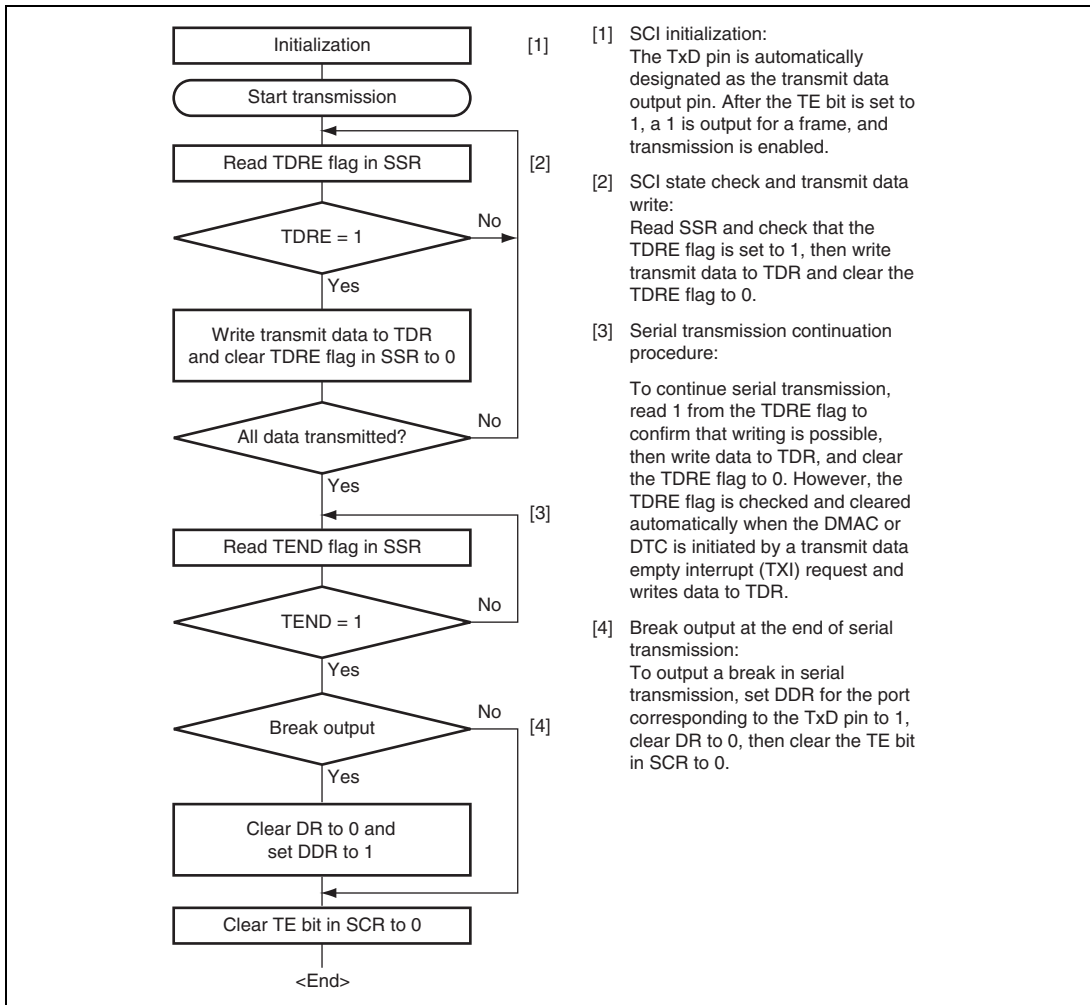
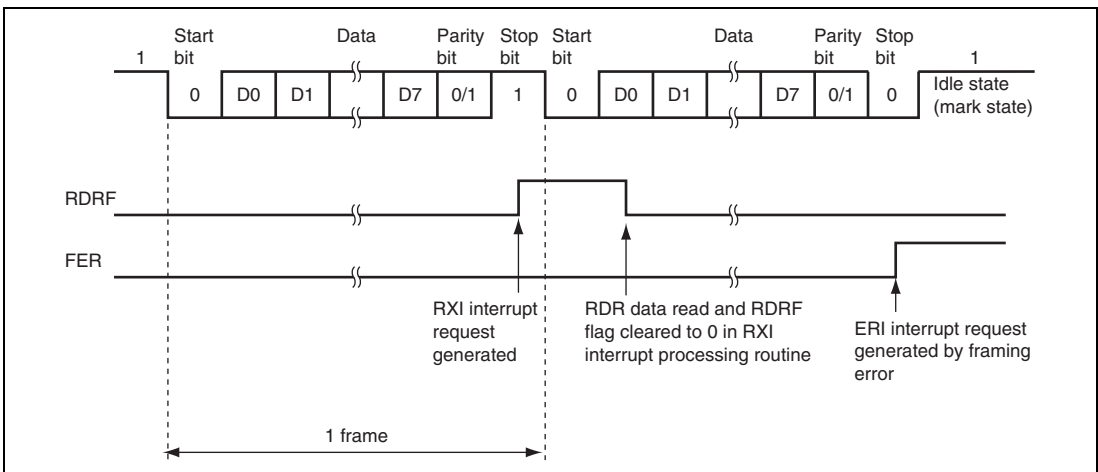

Figure 17.10 Example of Serial Transmission Flowchart

17.4.6 Serial Data Reception (Asynchronous Mode)

Figure 17.11 shows an example of the operation for reception in asynchronous mode. In serial reception, the SCI operates as described below.

1. The SCI monitors the communication line, and if a start bit is detected, performs internal synchronization, stores receive data in RSR, and checks the parity bit and stop bit.
2. If an overrun error (when reception of the next data is completed while the RDRF flag in SSR is still set to 1) occurs, the ORER bit in SSR is set to 1. If the RIE bit in SCR is set to 1 at this time, an ERI interrupt request is generated. Receive data is not transferred to RDR. The RDRF flag remains to be set to 1.
3. If a parity error is detected, the PER bit in SSR is set to 1 and receive data is transferred to RDR. If the RIE bit in SCR is set to 1 at this time, an ERI interrupt request is generated.
4. If a framing error (when the stop bit is 0) is detected, the FER bit in SSR is set to 1 and receive data is transferred to RDR. If the RIE bit in SCR is set to 1 at this time, an ERI interrupt request is generated.
5. If reception finishes successfully, the RDRF bit in SSR is set to 1, and receive data is transferred to RDR. If the RIE bit in SCR is set to 1 at this time, an RXI interrupt request is generated. Because the RXI interrupt processing routine reads the receive data transferred to RDR before reception of the next receive data has finished, continuous reception can be enabled.



**Figure 17.11 Example of SCI Operation for Reception
(Example with 8-Bit Data, Parity, One Stop Bit)**

Table 17.12 shows the states of the SSR status flags and receive data handling when a receive error is detected. If a receive error is detected, the RDRF flag retains its state before receiving data. Reception cannot be resumed while a receive error flag is set to 1. Accordingly, clear the ORER, FER, PER, and RDRF bits to 0 before resuming reception. Figure 17.12 shows a sample flowchart for serial data reception.

Table 17.12 SSR Status Flags and Receive Data Handling

SSR Status Flag				Receive Data	Receive Error Type
RDRF*	ORER	FER	PER		
1	1	0	0	Lost	Overrun error
0	0	1	0	Transferred to RDR	Framing error
0	0	0	1	Transferred to RDR	Parity error
1	1	1	0	Lost	Overrun error + framing error
1	1	0	1	Lost	Overrun error + parity error
0	0	1	1	Transferred to RDR	Framing error + parity error
1	1	1	1	Lost	Overrun error + framing error + parity error

Note: * The RDRF flag retains the state it had before data reception.

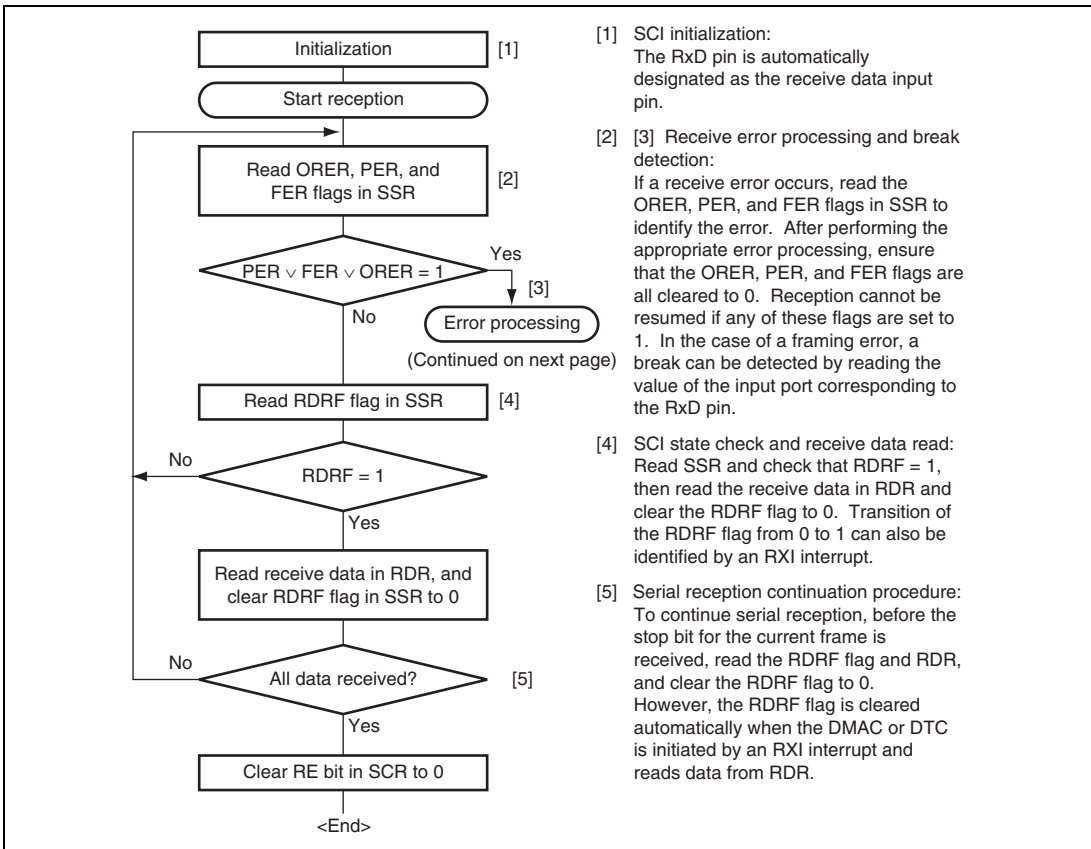

- [1] SCI initialization:
The RxD pin is automatically designated as the receive data input pin.
- [2] [3] Receive error processing and break detection:
If a receive error occurs, read the ORER, PER, and FER flags in SSR to identify the error. After performing the appropriate error processing, ensure that the ORER, PER, and FER flags are all cleared to 0. Reception cannot be resumed if any of these flags are set to 1. In the case of a framing error, a break can be detected by reading the value of the input port corresponding to the RxD pin.
- [4] SCI state check and receive data read:
Read SSR and check that RDRF = 1, then read the receive data in RDR and clear the RDRF flag to 0. Transition of the RDRF flag from 0 to 1 can also be identified by an RXI interrupt.
- [5] Serial reception continuation procedure:
To continue serial reception, before the stop bit for the current frame is received, read the RDRF flag and RDR, and clear the RDRF flag to 0. However, the RDRF flag is cleared automatically when the DMAC or DTC is initiated by an RXI interrupt and reads data from RDR.

Figure 17.12 Sample Serial Reception Flowchart (1)

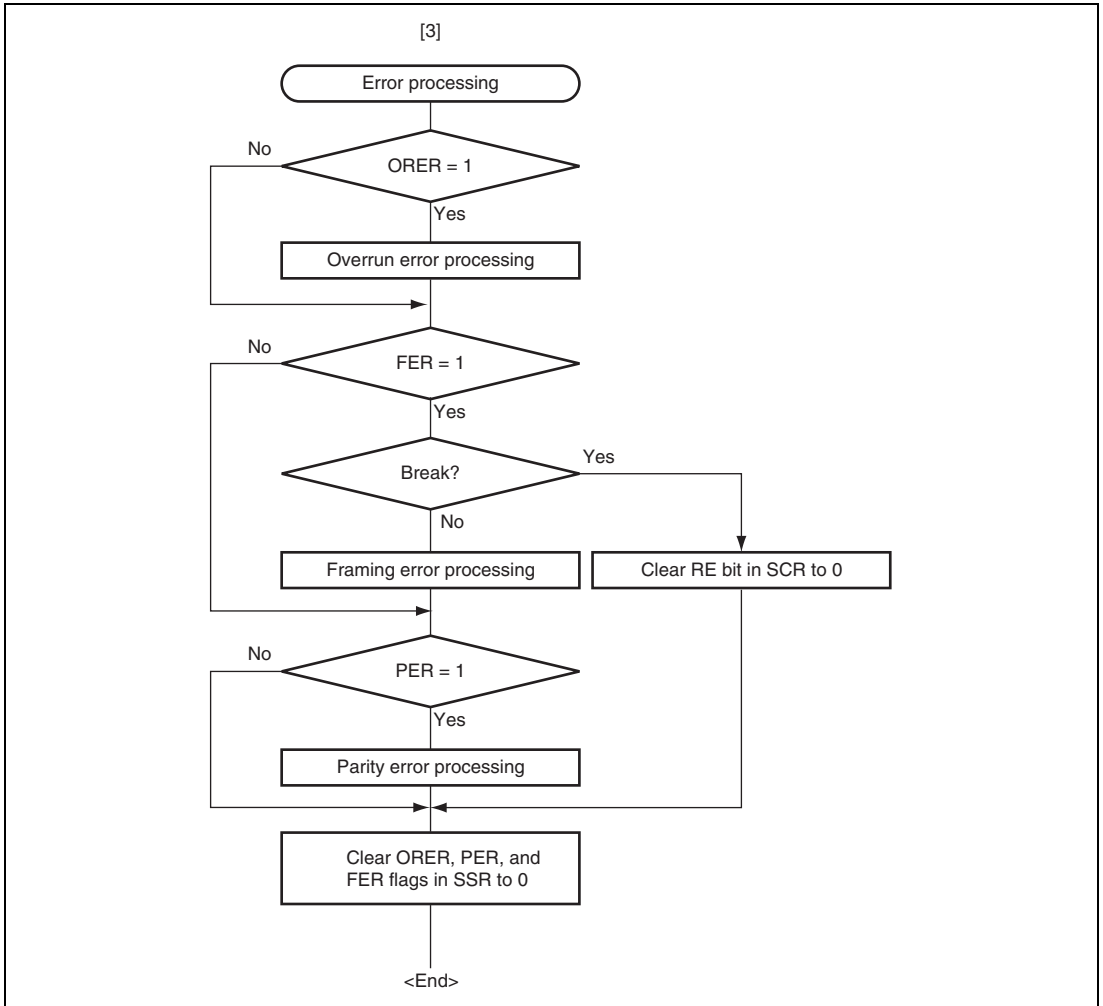

Figure 17.12 Sample Serial Reception Flowchart (2)

17.5 Multiprocessor Communication Function

Use of the multiprocessor communication function enables data transfer to be performed among a number of processors sharing communication lines by means of asynchronous serial communication using the multiprocessor format, in which a multiprocessor bit is added to the transfer data. When multiprocessor communication is carried out, each receiving station is addressed by a unique ID code. The serial communication cycle consists of two component cycles: an ID transmission cycle which specifies the receiving station, and a data transmission cycle for the specified receiving station. The multiprocessor bit is used to differentiate between the ID transmission cycle and the data transmission cycle. If the multiprocessor bit is 1, the cycle is an ID transmission cycle, and if the multiprocessor bit is 0, the cycle is a data transmission cycle. Figure 17.13 shows an example of inter-processor communication using the multiprocessor format. The transmitting station first sends data which includes the ID code of the receiving station and a multiprocessor bit set to 1. It then transmits transmit data added with a multiprocessor bit cleared to 0. The receiving station skips data until data with a 1 multiprocessor bit is sent. When data with a 1 multiprocessor bit is received, the receiving station compares that data with its own ID. The station whose ID matches then receives the data sent next. Stations whose ID does not match continue to skip data until data with a 1 multiprocessor bit is again received.

The SCI uses the MPIE bit in SCR to implement this function. When the MPIE bit is set to 1, transfer of receive data from RSR to RDR, error flag detection, and setting the SSR status flags, RDRF, FER, and ORER in SSR to 1 are prohibited until data with a 1 multiprocessor bit is received. On reception of a receive character with a 1 multiprocessor bit, the MPB bit in SSR is set to 1 and the MPIE bit is automatically cleared, thus normal reception is resumed. If the RIE bit in SCR is set to 1 at this time, an RXI interrupt is generated.

When the multiprocessor format is selected, the parity bit setting is invalid. All other bit settings are the same as those in normal asynchronous mode. The clock used for multiprocessor communication is the same as that in normal asynchronous mode.

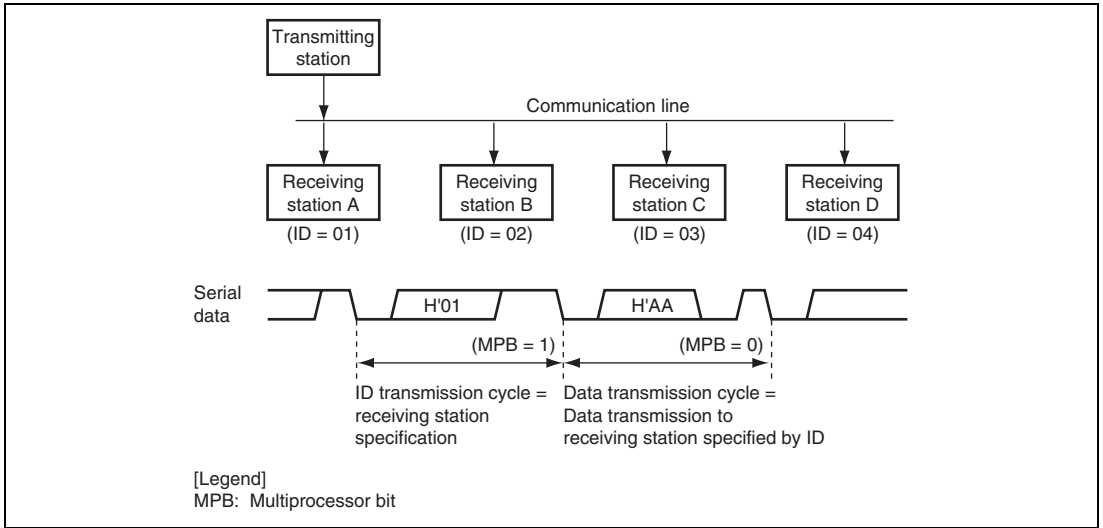

**Figure 17.13 Example of Communication Using Multiprocessor Format
(Transmission of Data H'AA to Receiving Station A)**

17.5.1 Multiprocessor Serial Data Transmission

Figure 17.14 shows a sample flowchart for multiprocessor serial data transmission. For an ID transmission cycle, set the MPBT bit in SSR to 1 before transmission. For a data transmission cycle, clear the MPBT bit in SSR to 0 before transmission. All other SCI operations are the same as those in asynchronous mode.

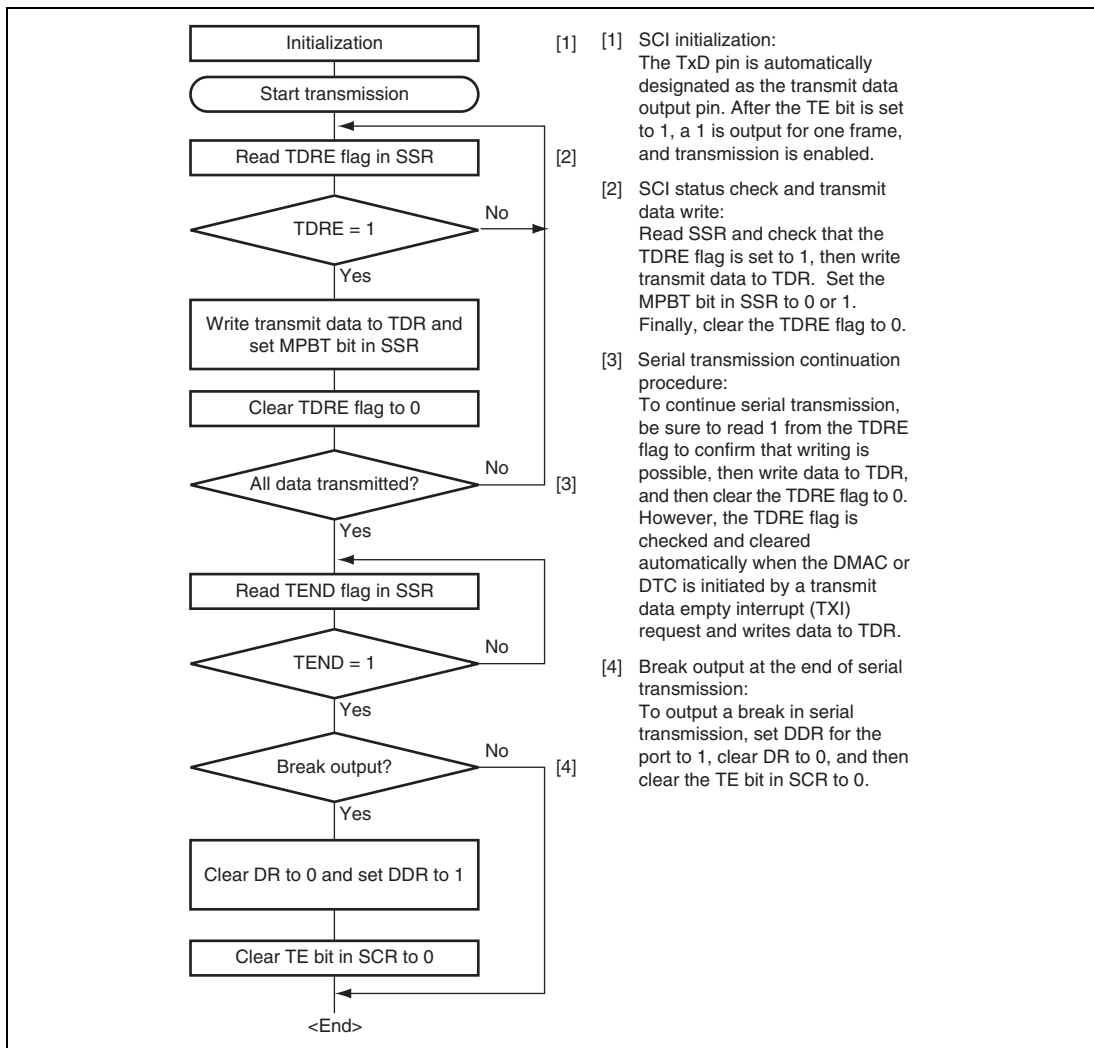
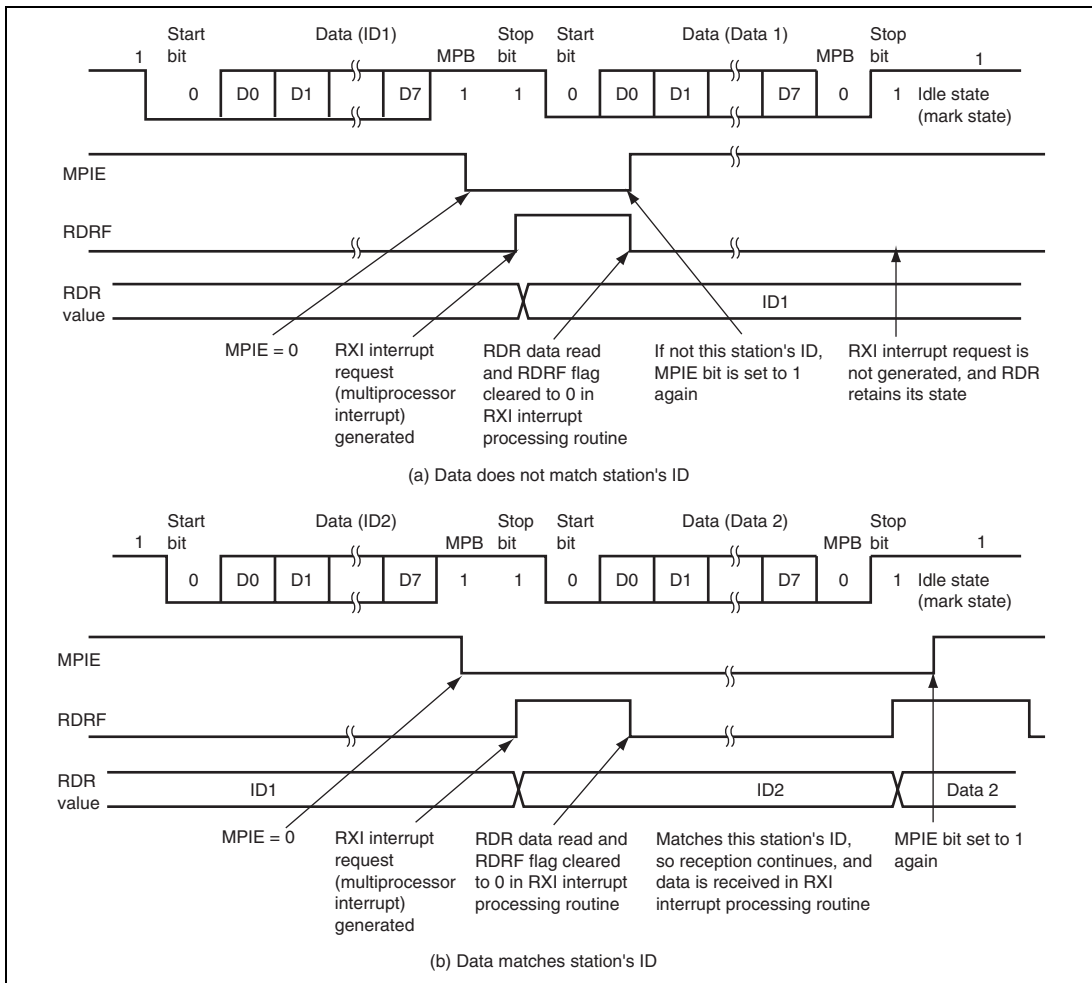

Figure 17.14 Sample Multiprocessor Serial Transmission Flowchart

17.5.2 Multiprocessor Serial Data Reception

Figure 17.16 shows a sample flowchart for multiprocessor serial data reception. If the MPIE bit in SCR is set to 1, data is skipped until data with a 1 multiprocessor bit is sent. On receiving data with a 1 multiprocessor bit, the receive data is transferred to RDR. An RXI interrupt request is generated at this time. All other SCI operations are the same as in asynchronous mode. Figure 17.15 shows an example of SCI operation for multiprocessor format reception.



**Figure 17.15 Example of SCI Operation for Reception
(Example with 8-Bit Data, Multiprocessor Bit, One Stop Bit)**

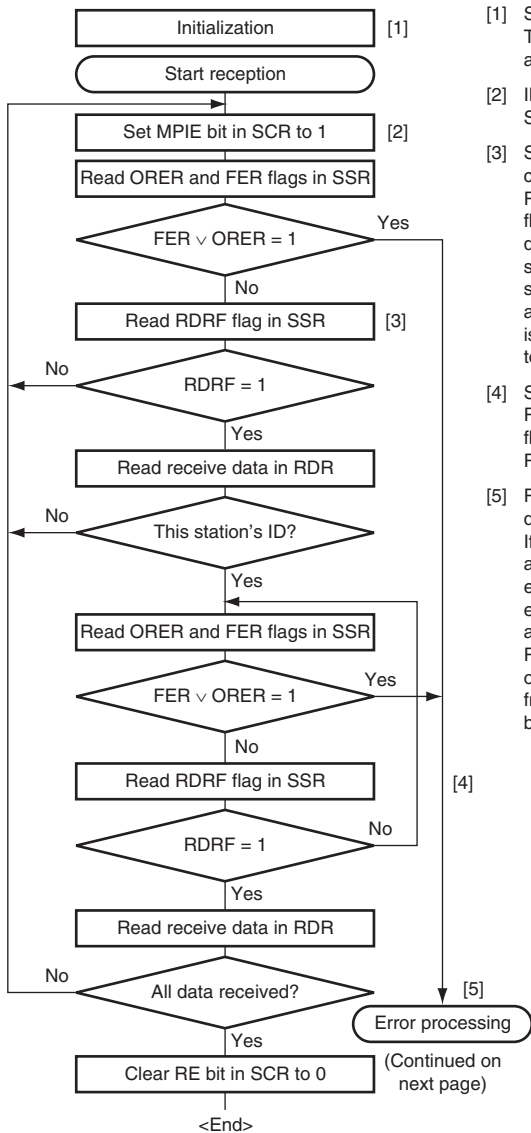

- [1] SCI initialization:
The RxD pin is automatically designated as the receive data input pin.
- [2] ID reception cycle:
Set the MPIE bit in SCR to 1.
- [3] SCI state check, ID reception and comparison:
Read SSR and check that the RDRF flag is set to 1, then read the receive data in RDR and compare it with this station's ID. If the data is not this station's ID, set the MPIE bit to 1 again, and clear the RDRF flag to 0. If the data is this station's ID, clear the RDRF flag to 0.
- [4] SCI state check and data reception:
Read SSR and check that the RDRF flag is set to 1, then read the data in RDR.
- [5] Receive error processing and break detection:
If a receive error occurs, read the ORER and FER flags in SSR to identify the error. After performing the appropriate error processing, ensure that the ORER and FER flags are both cleared to 0. Reception cannot be resumed if either of these flags is set to 1. In the case of a framing error, a break can be detected by reading the RxD pin value.

Figure 17.16 Sample Multiprocessor Serial Reception Flowchart (1)

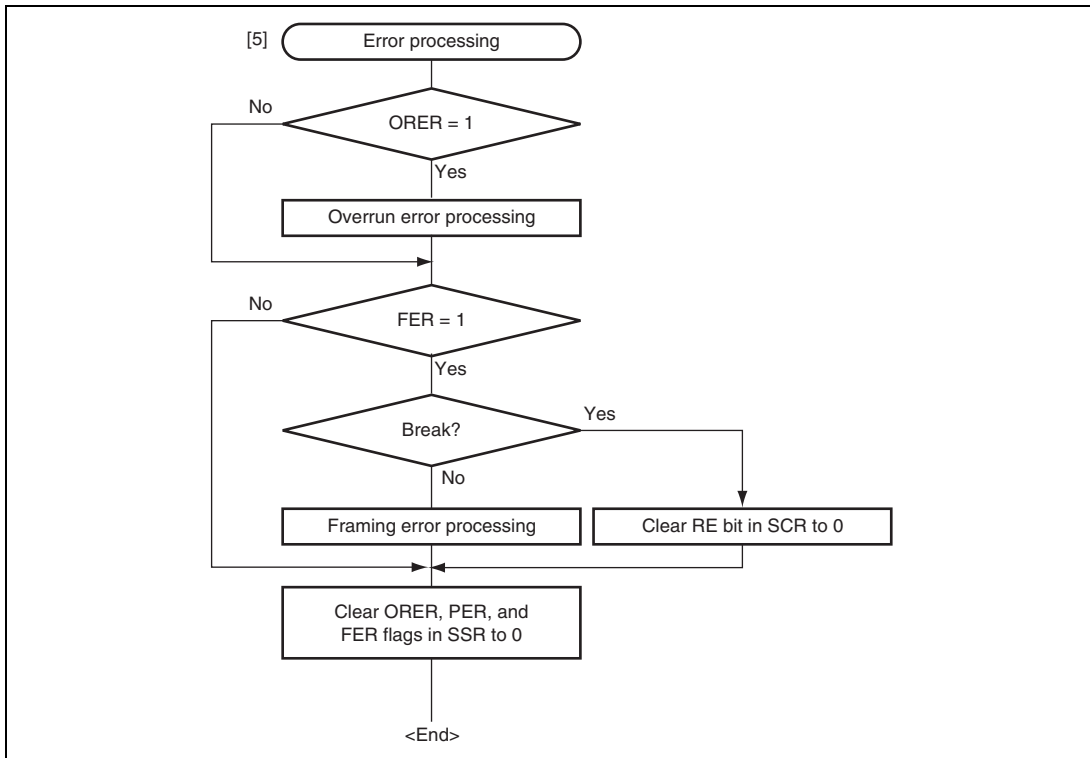

Figure 17.16 Sample Multiprocessor Serial Reception Flowchart (2)

17.6 Operation in Clock Synchronous Mode

Figure 17.17 shows the general format for clock synchronous communication. In clock synchronous mode, data is transmitted or received in synchronization with clock pulses. One character in transfer data consists of 8-bit data. In data transmission, the SCI outputs data from one falling edge of the synchronization clock to the next. In data reception, the SCI receives data in synchronization with the rising edge of the synchronization clock. After 8-bit data is output, the transmission line holds the MSB output state. In clock synchronous mode, no parity bit or multiprocessor bit is added. Inside the SCI, the transmitter and receiver are independent units, enabling full-duplex communication by use of a common clock. Both the transmitter and the receiver also have a double-buffered structure, so that the next transmit data can be written during transmission or the previous receive data can be read during reception, enabling continuous data transfer.

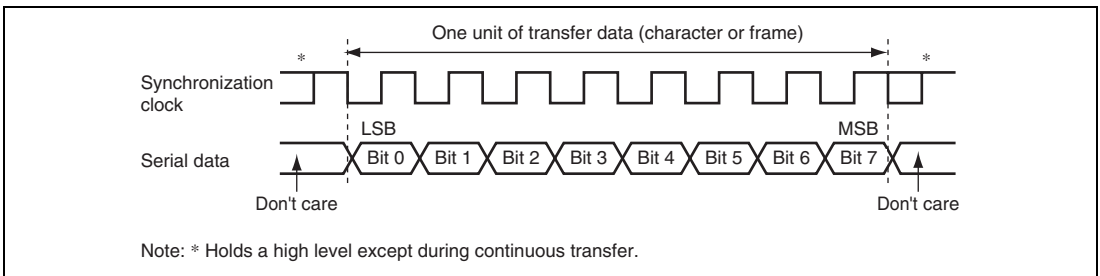

Figure 17.17 Data Format in Clock Synchronous Communication (LSB-First)

17.6.1 Clock

Either an internal clock generated by the on-chip baud rate generator or an external synchronization clock input at the SCK pin can be selected, according to the setting of the CKE1 and CKE0 bits in SCR. When the SCI is operated on an internal clock, the synchronization clock is output from the SCK pin. Eight synchronization clock pulses are output in the transfer of one character, and when no transfer is performed the clock is fixed high. Note that in the case of reception only, the synchronization clock is output until an overrun error occurs or until the RE bit is cleared to 0.

17.6.2 SCI Initialization (Clock Synchronous Mode)

Before transmitting and receiving data, first clear the TE and RE bits in SCR to 0, then initialize the SCI as described in a sample flowchart in Figure 17.18. When the operating mode, transfer format, etc., is changed, the TE and RE bits must be cleared to 0 before making the change. When the TE bit is cleared to 0, the TDRE flag is set to 1. However, clearing the RE bit to 0 does not initialize the RDRF, PER, FER, and ORER flags, or RDR.

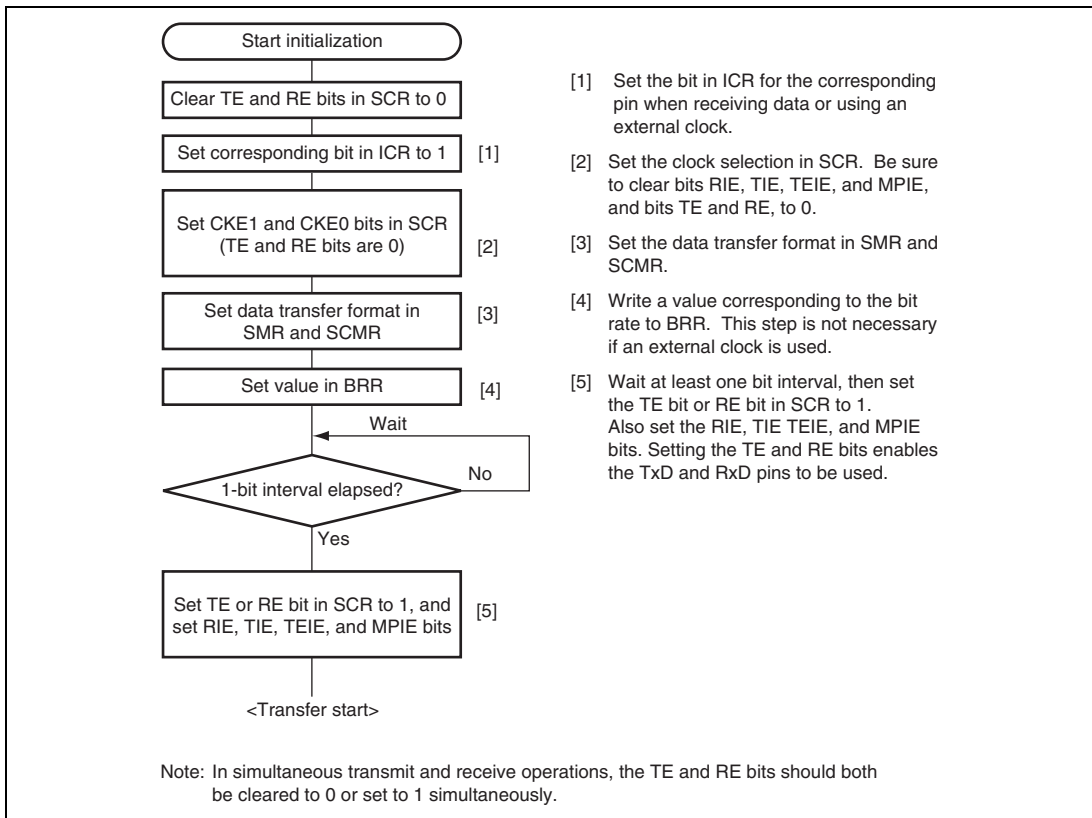

Figure 17.18 Sample SCI Initialization Flowchart

17.6.3 Serial Data Transmission (Clock Synchronous Mode)

Figure 17.19 shows an example of the operation for transmission in clock synchronous mode. In transmission, the SCI operates as described below.

1. The SCI monitors the TDRE flag in SSR, and if it is 0, recognizes that data has been written to TDR, and transfers the data from TDR to TSR.
2. After transferring data from TDR to TSR, the SCI sets the TDRE flag to 1 and starts transmission. If the TIE bit in SCR is set to 1 at this time, a TXI interrupt request is generated. Because the TXI interrupt processing routine writes the next transmit data to TDR before transmission of the current transmit data has finished, continuous transmission can be enabled.
3. 8-bit data is sent from the TxD pin synchronized with the output clock when clock output mode has been specified and synchronized with the input clock when use of an external clock has been specified.
4. The SCI checks the TDRE flag at the timing for sending the last bit.
5. If the TDRE flag is cleared to 0, the next transmit data is transferred from TDR to TSR, and serial transmission of the next frame is started.
6. If the TDRE flag is set to 1, the TEND flag in SSR is set to 1, and the TxD pin retains the output state of the last bit. If the TEIE bit in SCR is set to 1 at this time, a TEI interrupt request is generated. The SCK pin is fixed high.

Figure 17.20 shows a sample flowchart for serial data transmission. Even if the TDRE flag is cleared to 0, transmission will not start while a receive error flag (ORER, FER, or PER) is set to 1. Make sure to clear the receive error flags to 0 before starting transmission. Note that clearing the RE bit to 0 does not clear the receive error flags.

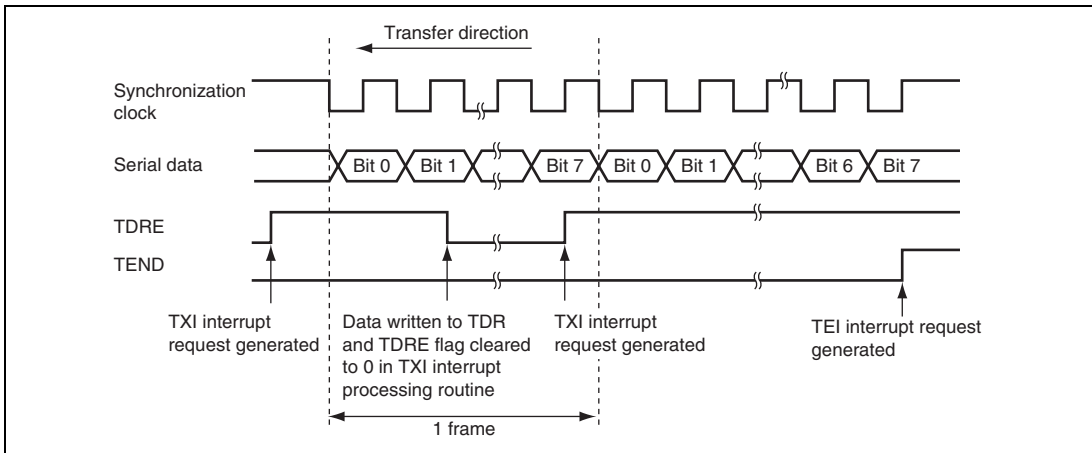

Figure 17.19 Example of Operation for Transmission in Clock Synchronous Mode

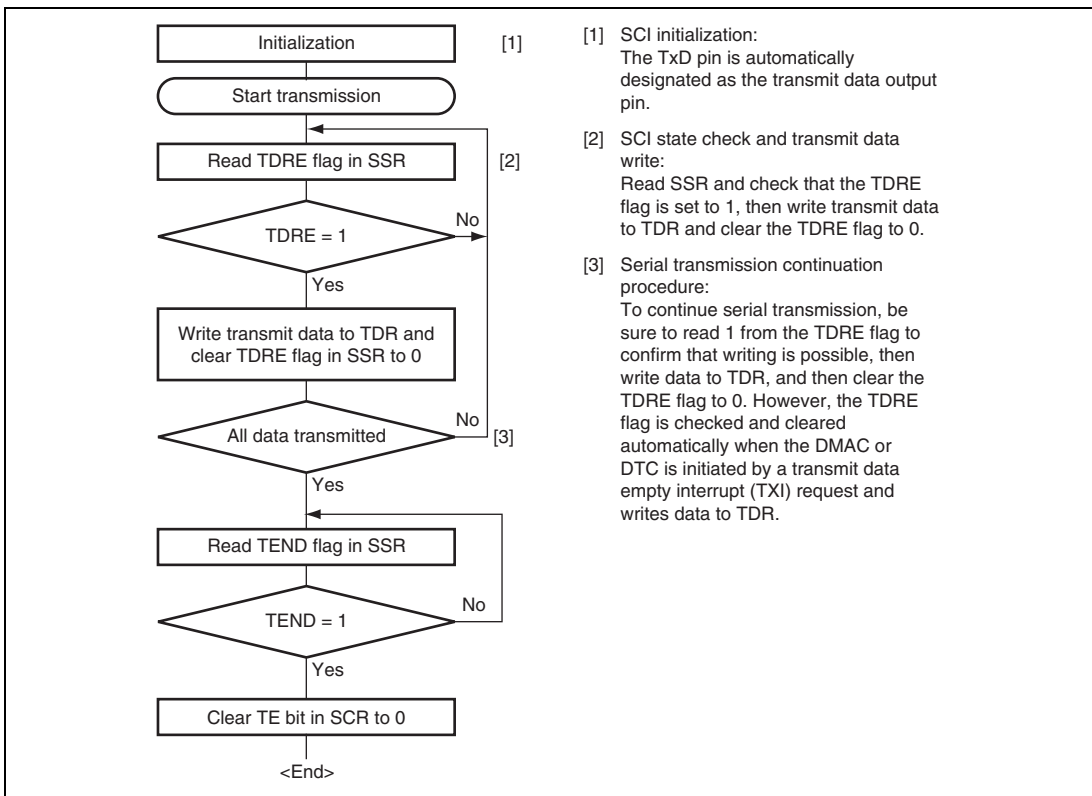

Figure 17.20 Sample Serial Transmission Flowchart

17.6.4 Serial Data Reception (Clock Synchronous Mode)

Figure 17.21 shows an example of SCI operation for reception in clock synchronous mode. In serial reception, the SCI operates as described below.

1. The SCI performs internal initialization in synchronization with a synchronization clock input or output, starts receiving data, and stores the receive data in RSR.
2. If an overrun error (when reception of the next data is completed while the RDRF flag in SSR is still set to 1) occurs, the ORER bit in SSR is set to 1. If the RIE bit in SCR is set to 1 at this time, an ERI interrupt request is generated. Receive data is not transferred to RDR. The RDRF flag remains to be set to 1.
3. If reception finishes successfully, the RDRF bit in SSR is set to 1, and receive data is transferred to RDR. If the RIE bit in SCR is set to 1 at this time, an RXI interrupt request is generated. Because the RXI interrupt processing routine reads the receive data transferred to RDR before reception of the next receive data has finished, continuous reception can be enabled.

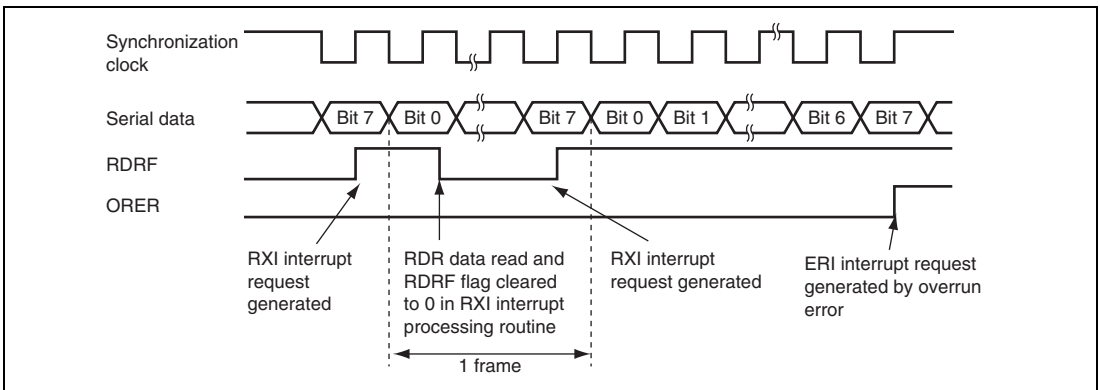

Figure 17.21 Example of Operation for Reception in Clock Synchronous Mode

Transfer cannot be resumed while a receive error flag is set to 1. Accordingly, clear the ORER, FER, PER, and RDRF bits to 0 before resuming reception. Figure 17.22 shows a sample flowchart for serial data reception.

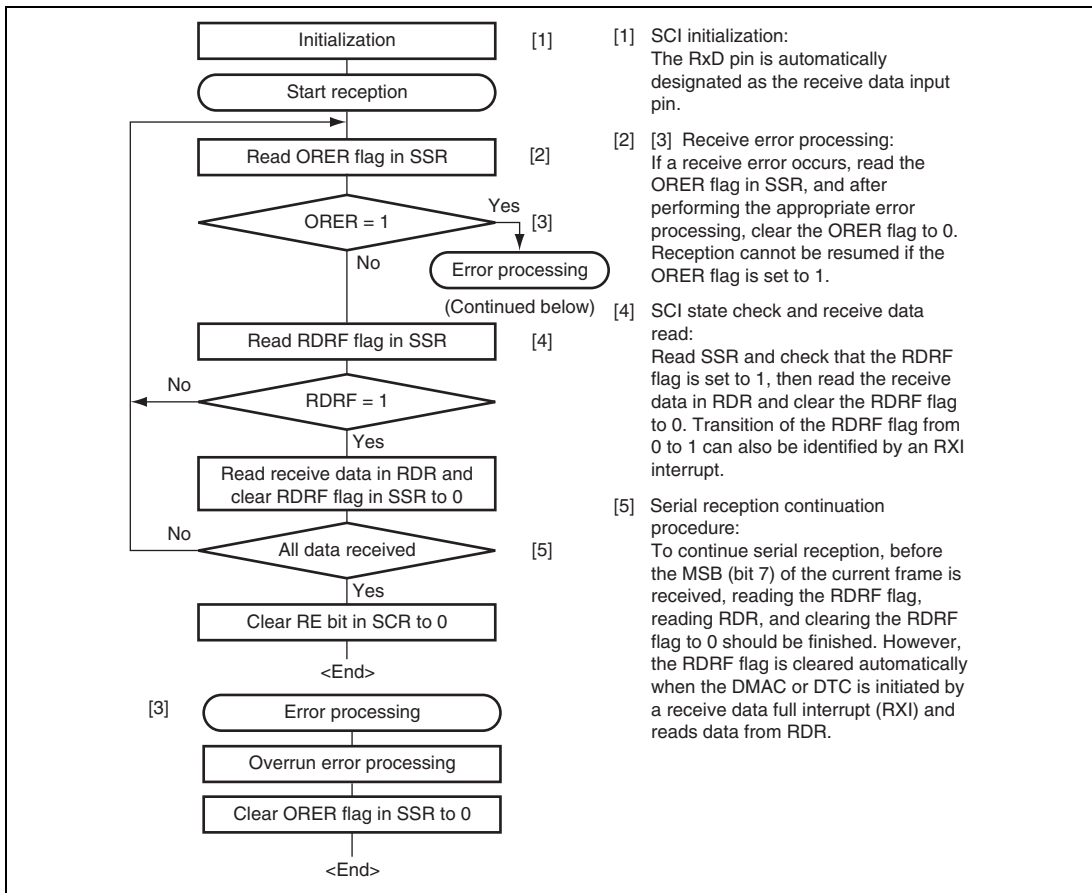
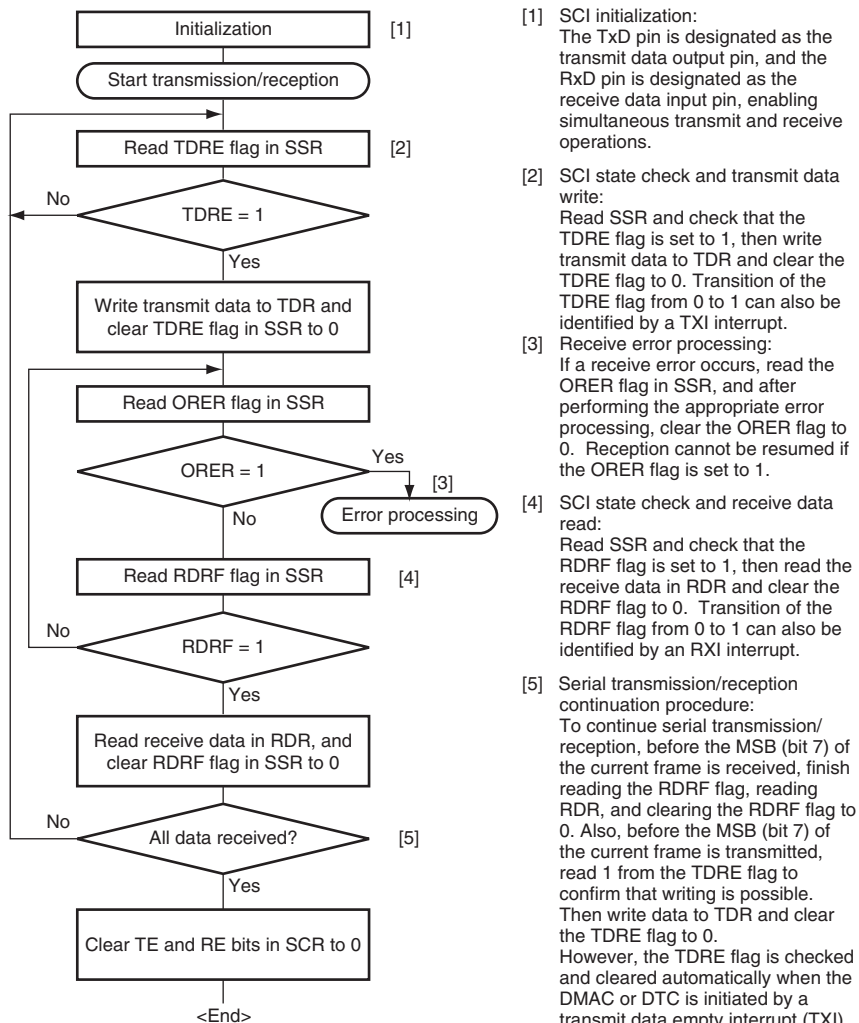

Figure 17.22 Sample Serial Reception Flowchart

17.6.5 Simultaneous Serial Data Transmission and Reception (Clock Synchronous Mode)

Figure 17.23 shows a sample flowchart for simultaneous serial transmit and receive operations. After initializing the SCI, the following procedure should be used for simultaneous serial data transmit and receive operations. To switch from transmit mode to simultaneous transmit and receive mode, after checking that the SCI has finished transmission and the TDRE and TEND flags are set to 1, clear the TE bit to 0. Then simultaneously set both the TE and RE bits to 1 with a single instruction. To switch from receive mode to simultaneous transmit and receive mode, after checking that the SCI has finished reception, clear the RE bit to 0. Then after checking that the RDRF bit and receive error flags (ORER, FER, and PER) are cleared to 0, simultaneously set both the TE and RE bits to 1 with a single instruction.



Note: When switching from transmit or receive operation to simultaneous transmit and receive operations, first clear the TE bit and RE bit to 0, then set both these bits to 1 simultaneously.

Figure 17.23 Sample Flowchart of Simultaneous Serial Transmission and Reception

17.7 Operation in Smart Card Interface Mode

The SCI supports the smart card interface, supporting the ISO/IEC 7816-3 (Identification Card) standard, as an extended serial communication interface function. Smart card interface mode can be selected using the appropriate register.

17.7.1 Sample Connection

Figure 17.24 shows a sample connection between the smart card and this LSI. As in the figure, since this LSI communicates with the smart card using a single transmission line, interconnect the TxD and RxD pins and pull up the data transmission line to V_{cc} using a resistor. Setting the RE and TE bits to 1 with the smart card not connected enables closed transmission/reception allowing self diagnosis. To supply the smart card with the clock pulses generated by the SCI, input the SCK pin output to the CLK pin of the smart card. A reset signal can be supplied via the output port of this LSI.

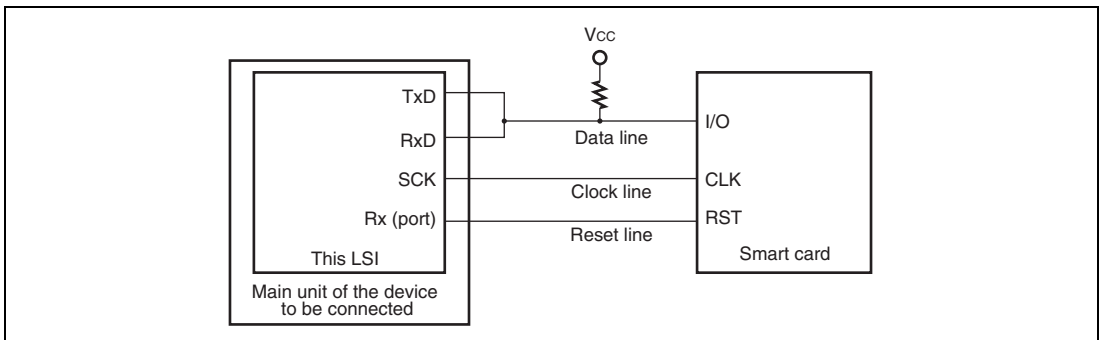

Figure 17.24 Pin Connection for Smart Card Interface

17.7.2 Data Format (Except in Block Transfer Mode)

Figure 17.25 shows the data transfer formats in smart card interface mode.

- One frame contains 8-bit data and a parity bit in asynchronous mode.
- During transmission, at least 2 etu (elementary time unit: time required for transferring one bit) is secured as a guard time after the end of the parity bit before the start of the next frame.
- If a parity error is detected during reception, a low error signal is output for 1 etu after 10.5 etu has passed from the start bit.
- If an error signal is sampled during transmission, the same data is automatically re-transmitted after at least 2 etu.

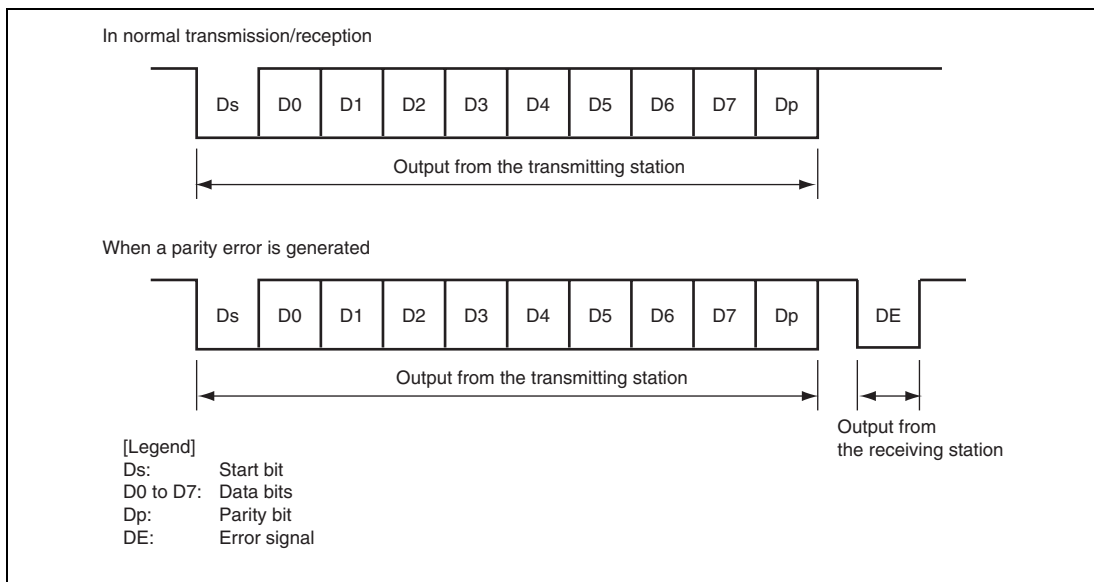

Figure 17.25 Data Formats in Normal Smart Card Interface Mode

For communication with the smart cards of the direct convention and inverse convention types, follow the procedure below.

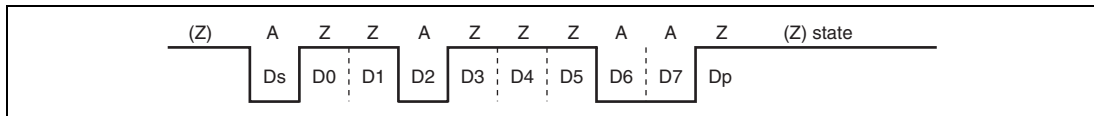

Figure 17.26 Direct Convention (SDIR = SINV = $\overline{O/E}$ = 0)

For the direct convention type, logic levels 1 and 0 correspond to states Z and A, respectively, and data is transferred with LSB-first as the start character, as shown in Figure 17.26. Therefore, data in the start character in the figure is H'3B. When using the direct convention type, write 0 to both the SDIR and SINV bits in SCMR. Write 0 to the $O\bar{E}$ bit in SMR in order to use even parity, which is prescribed by the smart card standard.

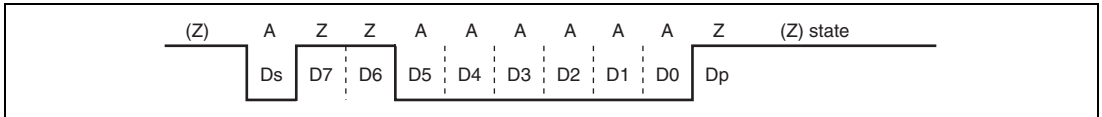

Figure 17.27 Inverse Convention (SDIR = SINV = $O\bar{E}$ = 1)

For the inverse convention type, logic levels 1 and 0 correspond to states A and Z, respectively and data is transferred with MSB-first as the start character, as shown in Figure 17.27. Therefore, data in the start character in the figure is H'3F. When using the inverse convention type, write 1 to both the SDIR and SINV bits in SCMR. The parity bit is logic level 0 to produce even parity, which is prescribed by the smart card standard, and corresponds to state Z. Since the SNIV bit of this LSI only inverts data bits D7 to D0, write 1 to the $O\bar{E}$ bit in SMR to invert the parity bit in both transmission and reception.

17.7.3 Block Transfer Mode

Block transfer mode is different from normal IrDA smart card interface mode in the following respects.

- Even if a parity error is detected during reception, no error signal is output. Since the PER bit in SSR is set by error detection, clear the PER bit before receiving the parity bit of the next frame.
- During transmission, at least 1 etu is secured as a guard time after the end of the parity bit before the start of the next frame.
- Since the same data is not re-transmitted during transmission, the TEND flag is set 11.5 etu after transmission start.
- Although the ERS flag in block transfer mode displays the error signal status as in normal smart card interface mode, the flag is always read as 0 because no error signal is transferred.

17.7.4 Receive Data Sampling Timing and Reception Margin

Only the internal clock generated by the on-chip baud rate generator can be used as a transfer clock in smart card interface mode. In this mode, the SCI can operate on a base clock with a frequency of 32, 64, 372, or 256 times the bit rate according to the BCP1 and BCP0 bit settings (the frequency is always 16 times the bit rate in normal asynchronous mode). At reception, the falling edge of the start bit is sampled using the base clock in order to perform internal synchronization. Receive data is sampled on the 16th, 32nd, 186th and 128th rising edges of the base clock so that it can be latched at the middle of each bit as shown in Figure 17.28. The reception margin here is determined by the following formula.

$$M = \left| \left(0.5 - \frac{1}{2N} \right) - (L - 0.5) F - \frac{|D - 0.5|}{N} (1 + F) \right| \times 100\%$$

[Legend]

M: Reception margin (%)

N: Ratio of bit rate to clock (N = 32, 64, 372, 256)

D: Duty cycle of clock (D = 0 to 1.0)

L: Frame length (L = 10)

F: Absolute value of clock frequency deviation

Assuming values of F = 0, D = 0.5, and N = 372 in the above formula, the reception margin is determined by the formula below.

$$M = \left(0.5 - \frac{1}{2 \times 372} \right) \times 100\% = 49.866\%$$

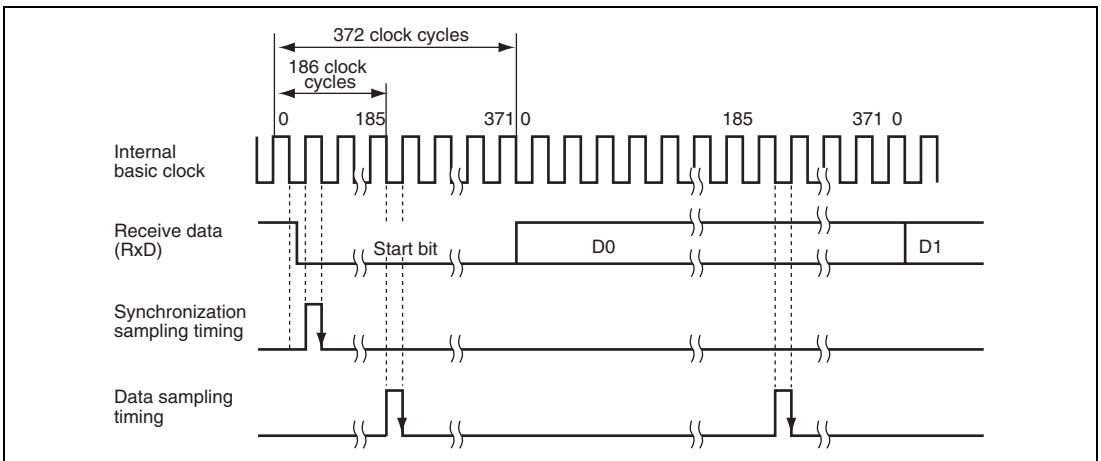

**Figure 17.28 Receive Data Sampling Timing in Smart Card Interface Mode
(When Clock Frequency is 372 Times the Bit Rate)**

17.7.5 Initialization

Before transmitting and receiving data, initialize the SCI using the following procedure. Initialization is also necessary before switching from transmission to reception and vice versa.

1. Clear the TE and RE bits in SCR to 0.
2. Set the ICR bit of the corresponding pin to 1.
3. Clear the error flags ERS, PER, and ORER in SSR to 0.
4. Set the GM, BLK, O/\bar{E} , BCP1, BCP0, CKS1, and CKS0 bits in SMR appropriately. Also set the PE bit to 1.
5. Set the SMIF, SDIR, and SINV bits in SCMR appropriately. When the DDR corresponding to the TxD pin is cleared to 0, the TxD and RxD pins are changed from port pins to SCI pins, placing the pins into high impedance state.
6. Set the value corresponding to the bit rate in BRR.
7. Set the CKE1 and CKE0 bits in SCR appropriately. Clear the TIE, RIE, TE, RE, MPIE, and TEIE bits to 0 simultaneously.

When the CKE0 bit is set to 1, the SCK pin is allowed to output clock pulses.

8. Set the TIE, RIE, TE, and RE bits in SCR appropriately after waiting for at least a 1-bit interval. Setting the TE and RE bits to 1 simultaneously is prohibited except for self diagnosis.

To switch from reception to transmission, first verify that reception has completed, then initialize the SCI. At the end of initialization, RE and TE should be set to 0 and 1, respectively. Reception completion can be verified by reading the RDRF, PER, or ORER flag. To switch from transmission to reception, first verify that transmission has completed, then initialize the SCI. At the end of initialization, TE and RE should be set to 0 and 1, respectively. Transmission completion can be verified by reading the TEND flag.

17.7.6 Data Transmission (Except in Block Transfer Mode)

Data transmission in smart card interface mode (except in block transfer mode) is different from that in normal serial communication interface mode in that an error signal is sampled and data can be re-transmitted. Figure 17.29 shows the data re-transfer operation during transmission.

1. If an error signal from the receiving end is sampled after one frame of data has been transmitted, the ERS bit in SSR is set to 1. Here, an ERI interrupt request is generated if the RIE bit in SCR is set to 1. Clear the ERS bit to 0 before the next parity bit is sampled.
2. For the frame in which an error signal is received, the TEND bit in SSR is not set to 1. Data is re-transferred from TDR to TSR allowing automatic data retransmission.
3. If no error signal is returned from the receiving end, the ERS bit in SSR is not set to 1.
4. In this case, one frame of data is determined to have been transmitted including re-transfer, and the TEND bit in SSR is set to 1. Here, a TXI interrupt request is generated if the TIE bit in SCR is set to 1. Writing transmit data to TDR starts transmission of the next data.

Figure 17.31 shows a sample flowchart for transmission. All the processing steps are automatically performed using a TXI interrupt request to activate the DTC or DMAC. In transmission, the TEND and TDRE flags in SSR are simultaneously set to 1, thus generating a TXI interrupt request if the TIE bit in SCR has been set to 1. This activates the DTC or DMAC by a TXI request thus allowing transfer of transmit data if the TXI interrupt request is specified as a source of DTC or DMAC activation beforehand. The TDRE and TEND flags are automatically cleared to 0 at data transfer by the DTC or DMAC. If an error occurs, the SCI automatically re-transmits the same data. During re-transmission, TEND remains as 0, thus not activating the DTC or DMAC. Therefore, the SCI and DTC or DMAC automatically transmit the specified number of bytes, including re-transmission in the case of error occurrence. However, the ERS flag is not automatically cleared; the ERS flag must be cleared by previously setting the RIE bit to 1 to enable an ERI interrupt request to be generated at error occurrence.

When transmitting/receiving data using the DTC or DMAC, be sure to set and enable the DTC or DMAC prior to making SCI settings. For DTC or DMAC settings, see section 11, Data Transfer Controller (DTC) and section 10, DMA Controller (DMAC).

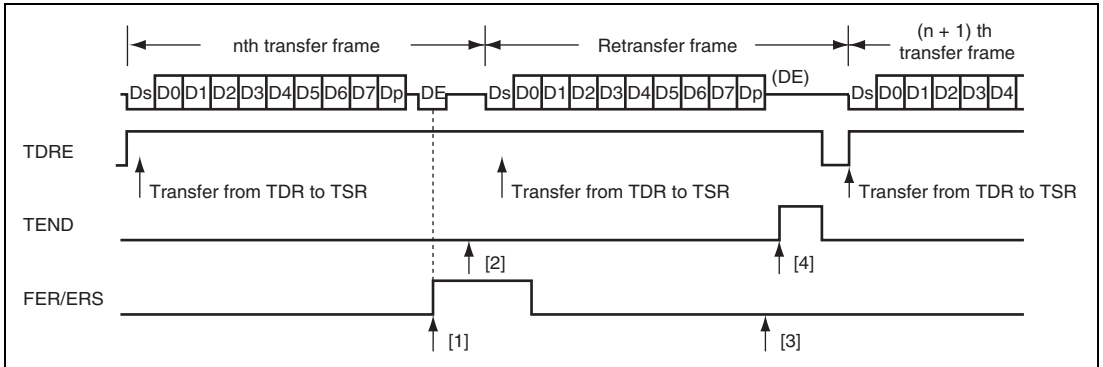

Figure 17.29 Data Re-Transfer Operation in SCI Transmission Mode

Note that the TEND flag is set in different timings depending on the GM bit setting in SMR. Figure 17.30 shows the TEND flag set timing.

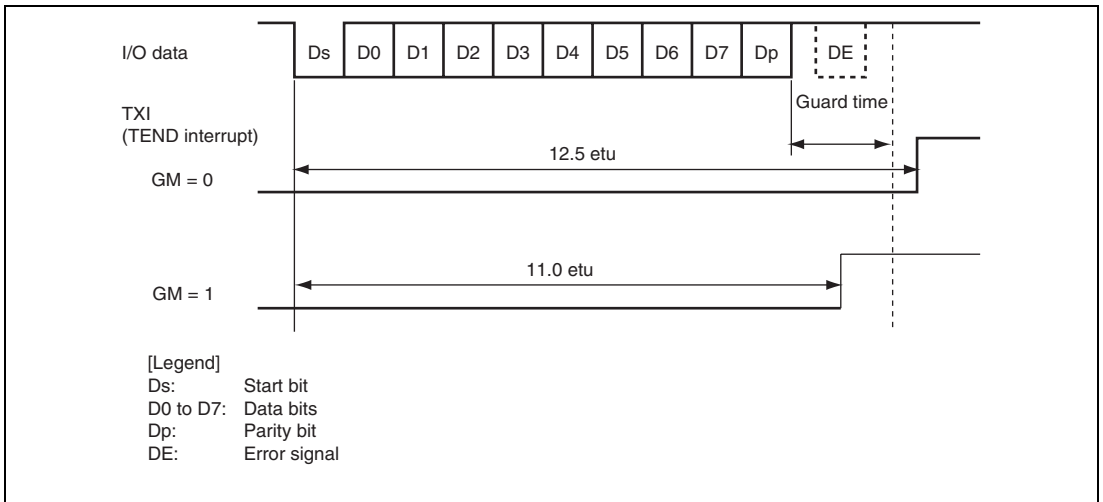

Figure 17.30 TEND Flag Set Timing during Transmission

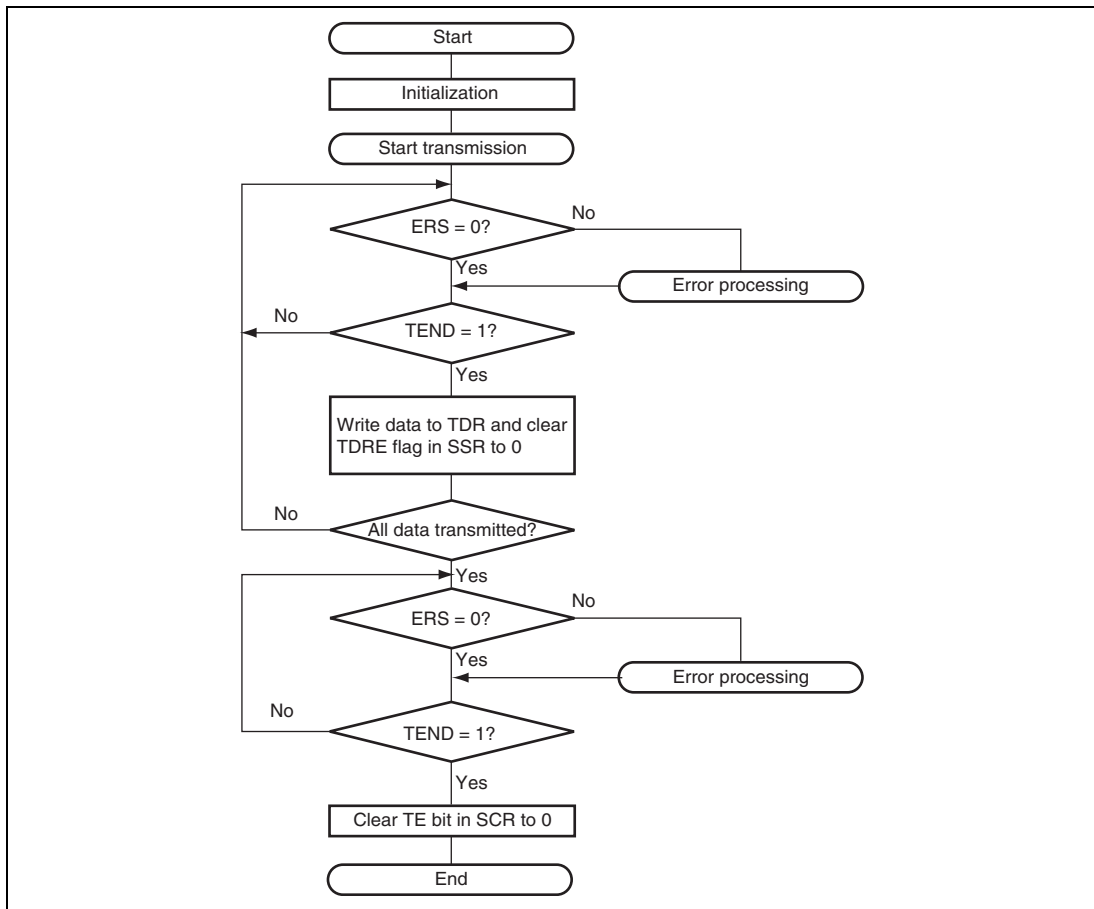

Figure 17.31 Sample Transmission Flowchart

17.7.7 Serial Data Reception (Except in Block Transfer Mode)

Data reception in smart card interface mode is similar to that in normal serial communication interface mode. Figure 17.32 shows the data re-transfer operation during reception.

1. If a parity error is detected in receive data, the PER bit in SSR is set to 1. Here, an ERI interrupt request is generated if the RIE bit in SCR is set to 1. Clear the PER bit to 0 before the next parity bit is sampled.
2. For the frame in which a parity error is detected, the RDRF bit in SSR is not set to 1.
3. If no parity error is detected, the PER bit in SSR is not set to 1.
4. In this case, data is determined to have been received successfully, and the RDRF bit in SSR is set to 1. Here, an RXI interrupt request is generated if the RIE bit in SCR is set to 1.

Figure 17.33 shows a sample flowchart for reception. All the processing steps are automatically performed using an RXI interrupt request to activate the DTC or DMAC. In reception, setting the RIE bit to 1 allows an RXI interrupt request to be generated when the RDRF flag is set to 1. This activates the DTC or DMAC by an RXI request thus allowing transfer of receive data if the RXI interrupt request is specified as a source of DTC or DMAC activation beforehand. The RDRF flag is automatically cleared to 0 at data transfer by the DTC or DMAC. If an error occurs during reception, i.e., either the ORER or PER flag is set to 1, a transmit/receive error interrupt (ERI) request is generated and the error flag must be cleared. If an error occurs, the DTC or DMAC is not activated and receive data is skipped, therefore, the number of bytes of receive data specified in the DTC or DMAC is transferred. Even if a parity error occurs and the PER bit is set to 1 in reception, receive data is transferred to RDR, thus allowing the data to be read.

Note: For operations in block transfer mode, see section 17.4, Operation in Asynchronous Mode.

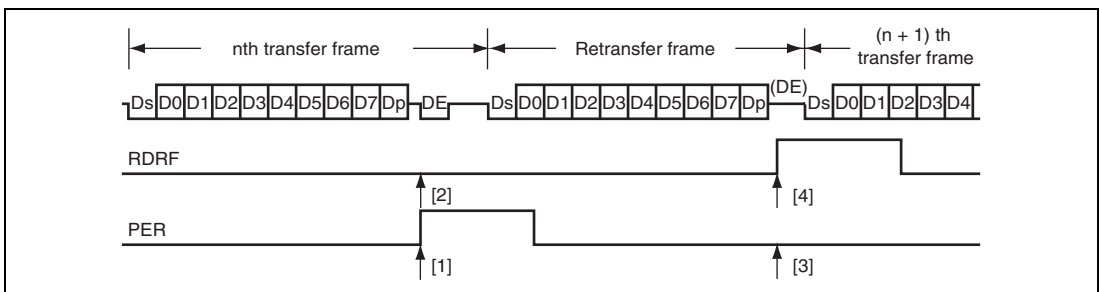

Figure 17.32 Data Re-Transfer Operation in SCI Reception Mode

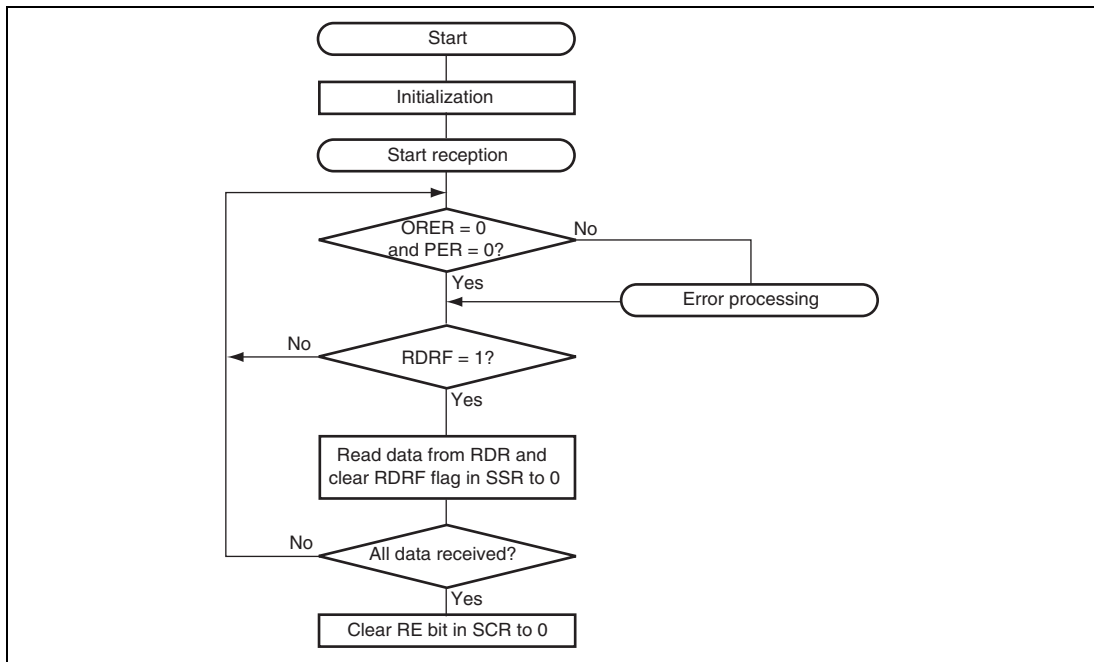

Figure 17.33 Sample Reception Flowchart

17.7.8 Clock Output Control

Clock output can be fixed using the CKE1 and CKE0 bits in SCR when the GM bit in SMR is set to 1. Specifically, the minimum width of a clock pulse can be specified.

Figure 17.34 shows an example of clock output fixing timing when the CKE0 bit is controlled with GM = 1 and CKE1 = 0.

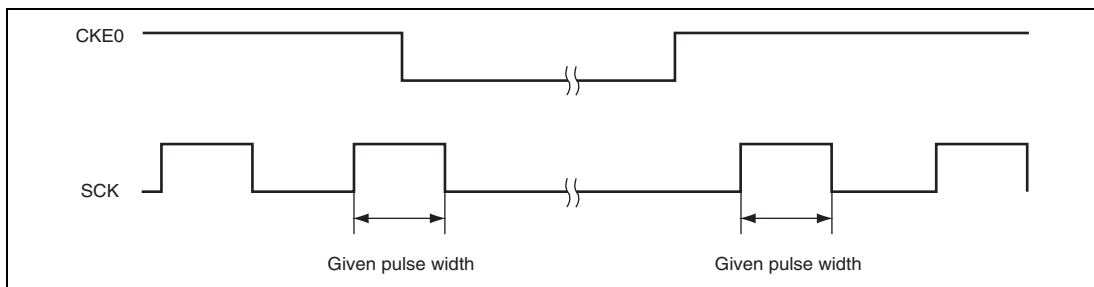

Figure 17.34 Clock Output Fixing Timing

At power-on and transitions to/from software standby mode, use the following procedure to secure the appropriate clock duty cycle.

- At power-on
 - To secure the appropriate clock duty cycle simultaneously with power-on, use the following procedure.
 1. Initially, port input is enabled in the high-impedance state. To fix the potential level, use a pull-up or pull-down resistor.
 2. Fix the SCK pin to the specified output using the CKE1 bit in SCR.
 3. Set SMR and SCMR to enable smart card interface mode.
Set the CKE0 bit in SCR to 1 to start clock output.
- At mode switching
 - At transition from smart card interface mode to software standby mode
 1. Set the data register (DR) and data direction register (DDR) corresponding to the SCK pin to the values for the output fixed state in software standby mode.
 2. Write 0 to the TE and RE bits in SCR to stop transmission/reception. Simultaneously, set the CKE1 bit to the value for the output fixed state in software standby mode.
 3. Write 0 to the CKE0 bit in SCR to stop the clock.
 4. Wait for one cycle of the serial clock. In the mean time, the clock output is fixed to the specified level with the duty cycle retained.
 5. Make the transition to software standby mode.
 - At transition from smart card interface mode to software standby mode
 1. Clear software standby mode.
 2. Write 1 to the CKE0 bit in SCR to start clock output. A clock signal with the appropriate duty cycle is then generated.

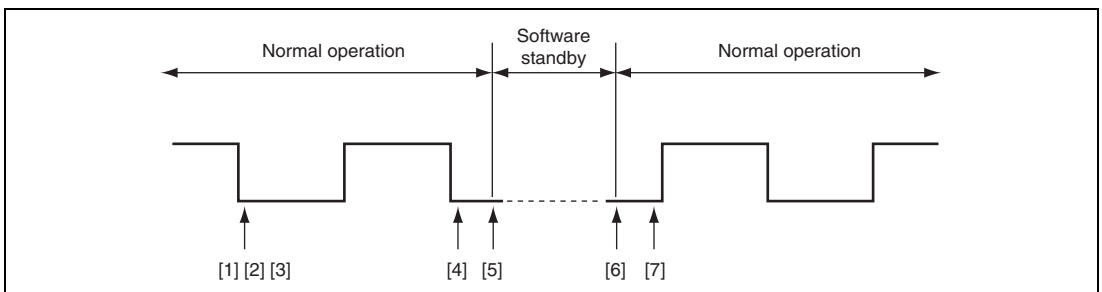

Figure 17.35 Clock Stop and Restart Procedure

17.8 IrDA Operation

If the IrDA function is enabled using the IrE bit in IrCR, the TxD5 and RxD5 pins in SCI_5 are allowed to encode and decode the waveform based on the IrDA Specifications version 1.0 (function as the IrTxD and IrRxD pins)*. Connecting these pins to the infrared data transceiver achieves infrared data communication based on the system defined by the IrDA Specifications version 1.0.

In the system defined by the IrDA Specifications version 1.0, communication is started at a transfer rate of 9600 bps, which can be modified later as required. Since the IrDA interface provided by this LSI does not incorporate the capability of automatic modification of the transfer rate, the transfer rate must be modified through programming.

Figure 17.36 shows the IrDA block diagram.

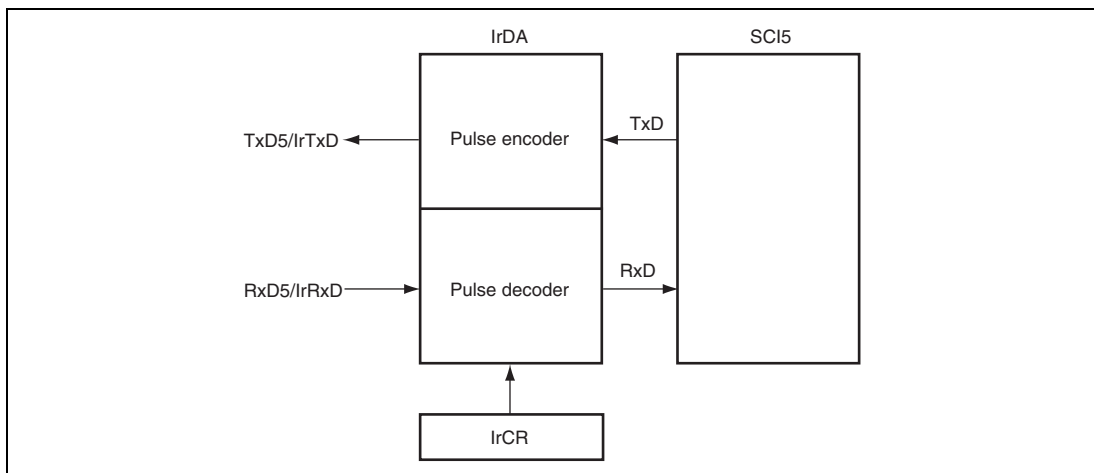

Figure 17.36 IrDA Block Diagram

Note: * The IrDA function should be used when the ABCS bit in SEMR_5 is set to 0 and the ACS3 to ACS0 bits in SEMR_5 and SEMR_6 are set to B'0000.

(1) Transmission

During transmission, the output signals from the SCI (UART frames) are converted to IR frames using the IrDA interface (see Figure 17.37).

For serial data of level 0, a high-level pulse having a width of $3/16$ of the bit rate (1-bit interval) is output (initial setting). The high-level pulse can be selected using the IrCKS2 to IrCKS0 bits in IrCR.

The high-level pulse width is defined to be $1.41 \mu\text{s}$ at minimum and $(3/16 + 2.5\%) \times \text{bit rate}$ or $(3/16 \times \text{bit rate}) + 1.08 \mu\text{s}$ at maximum. For example, when the frequency of system clock ϕ is 20 MHz, a high-level pulse width of $1.6 \mu\text{s}$ can be specified because it is the smallest value in the range greater than $1.41 \mu\text{s}$.

For serial data of level 1, no pulses are output.

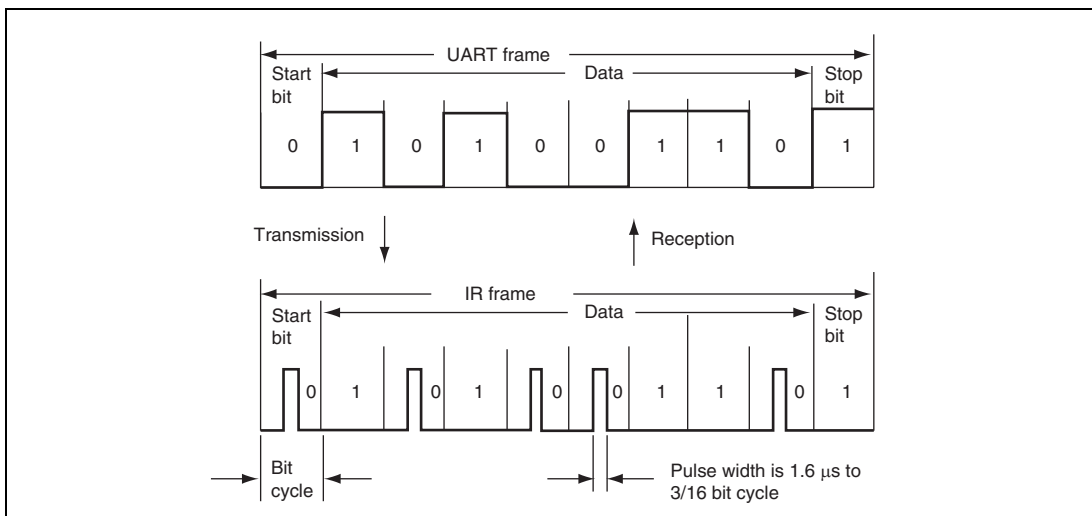

Figure 17.37 IrDA Transmission and Reception

(2) Reception

During reception, IR frames are converted to UART frames using the IrDA interface before inputting to SCI. 0 is output when the high level pulse is detected while 1 is output when no pulse is detected during one bit period. Note that a pulse shorter than the minimum pulse width of $1.41 \mu\text{s}$ is also regarded as a 0 signal.

(3) High-Level Pulse Width Selection

Table 17.13 shows possible settings for bits IrCKS2 to IrCKS0 (minimum pulse width), and this LSI's operating frequencies and bit rates, for making the pulse width shorter than 3/16 times the bit rate in transmission.

Table 17.13 IrCKS2 to IrCKS0 Bit Settings

Operating Frequency	Bit Rate (bps) (Upper Row)/Bit Interval × 3/16 (μs) (Lower Row)					
	2400	9600	19200	38400	57600	115200
Pφ (MHz)	78.13	19.53	9.77	4.88	3.26	1.63
7.3728	100	100	100	100	100	100
8	100	100	100	100	100	100
9.8304	100	100	100	100	100	100
10	100	100	100	100	100	100
12	101	101	101	101	101	101
12.288	101	101	101	101	101	101
14	101	101	101	101	101	101
14.7456	101	101	101	101	101	101
16	101	101	101	101	101	101
17.2032	101	101	101	101	101	101
18	101	101	101	101	101	101
19.6608	101	101	101	101	101	101
20	101	101	101	101	101	101
25	110	110	110	110	110	110
30	110	110	110	110	110	110
33	110	110	110	110	110	110
35	110	110	110	110	110	110

17.9 Interrupt Sources

17.9.1 Interrupts in Normal Serial Communication Interface Mode

Table 17.14 shows the interrupt sources in normal serial communication interface mode. A different interrupt vector is assigned to each interrupt source, and individual interrupt sources can be enabled or disabled using the enable bits in SCR.

When the TDRE flag in SSR is set to 1, a TXI interrupt request is generated. When the TEND flag in SSR is set to 1, a TEI interrupt request is generated. A TXI interrupt request can activate the DTC or DMAC to allow data transfer. The TDRE flag is automatically cleared to 0 at data transfer by the DTC or DMAC.

When the RDRF flag in SSR is set to 1, an RXI interrupt request is generated. When the ORER, PER, or FER flag in SSR is set to 1, an ERI interrupt request is generated. An RXI interrupt can activate the DTC or DMAC to allow data transfer. The RDRF flag is automatically cleared to 0 at data transfer by the DTC or DMAC.

A TEI interrupt is requested when the TEND flag is set to 1 while the TEIE bit is set to 1. If a TEI interrupt and a TXI interrupt are requested simultaneously, the TXI interrupt has priority for acceptance. However, note that if the TDRE and TEND flags are cleared to 0 simultaneously by the TXI interrupt processing routine, the SCI cannot branch to the TEI interrupt processing routine later.

Note that the priority order for interrupts is different between the group of SCI_0, 1, 2, 3, and 4 and the group of SCI_5 and SCI_6.

Table 17.14 SCI Interrupt Sources (SCI_0, 1, 2, 3, and 4)

Name	Interrupt Source	Interrupt Flag	DTC Activation	DMAC Activation	Priority
ERI	Receive error	ORER, FER, or PER	Not possible	Not possible	High
RXI	Receive data full	RDRF	Possible	Possible	↑ Low
TXI	Transmit data empty	TDRE	Possible	Possible	
TEI	Transmit end	TEND	Not possible	Not possible	

Table 17.15 SCI Interrupt Sources (SCI_5 and SCI_6)

Name	Interrupt Source	Interrupt Flag	DTC Activation	DMAC Activation	Priority
RXI	Receive data full	RDRF	Not possible	Possible	High
TXI	Transmit data empty	TDRE	Not possible	Possible	
ERI	Receive error	ORER, FER, or PER	Not possible	Not possible	
TEI	Transmit end	TEND	Not possible	Not possible	Low

17.9.2 Interrupts in Smart Card Interface Mode

Table 17.16 shows the interrupt sources in smart card interface mode. A transmit end (TEI) interrupt request cannot be used in this mode.

Note that the priority order for interrupts is different between the group of SCI_0, 1, 2, 3, and 4 and the group of SCI_5 and SCI_6.

Table 17.16 SCI Interrupt Sources (SCI_0, 1, 2, 3, and 4)

Name	Interrupt Source	Interrupt Flag	DTC Activation	DMAC Activation	Priority
ERI	Receive error or error signal detection	ORER, PER, or ERS	Not possible	Not possible	High
RXI	Receive data full	RDRF	Possible	Possible	
TXI	Transmit data empty	TEND	Possible	Possible	Low

Table 17.17 SCI Interrupt Sources (SCI_5 and SCI_6)

Name	Interrupt Source	Interrupt Flag	DTC Activation	DMAC Activation	Priority
RXI	Receive data full	RDRF	Not possible	Possible	High
TXI	Transmit data empty	TDRE	Not possible	Possible	
ERI	Receive error or error signal detection	ORER, PER, or ERS	Not possible	Not possible	Low

Data transmission/reception using the DTC or DMAC is also possible in smart card interface mode, similar to in the normal SCI mode. In transmission, the TEND and TDRE flags in SSR are simultaneously set to 1, thus generating a TXI interrupt. This activates the DTC or DMAC by a TXI request thus allowing transfer of transmit data if the TXI request is specified as a source of DTC or DMAC activation beforehand. The TDRE and TEND flags are automatically cleared to 0 at data transfer by the DTC or DMAC. If an error occurs, the SCI automatically re-transmits the same data. During re-transmission, the TEND flag remains as 0, thus not activating the DTC or DMAC. Therefore, the SCI and DTC or DMAC automatically transmit the specified number of bytes, including re-transmission in the case of error occurrence. However, the ERS flag in SSR, which is set at error occurrence, is not automatically cleared; the ERS flag must be cleared by previously setting the RIE bit in SCR to 1 to enable an ERI interrupt request to be generated at error occurrence.

When transmitting/receiving data using the DTC or DMAC, be sure to set and enable the DTC or DMAC prior to making SCI settings. For DTC or DMAC settings, see section 11, Data Transfer Controller (DTC) and section 10, DMA Controller (DMAC).

In reception, an RXI interrupt request is generated when the RDRF flag in SSR is set to 1. This activates the DTC or DMAC by an RXI request thus allowing transfer of receive data if the RXI request is specified as a source of DTC or DMAC activation beforehand. The RDRF flag is automatically cleared to 0 at data transfer by the DTC or DMAC. If an error occurs, the RDRF flag is not set but the error flag is set. Therefore, the DTC or DMAC is not activated and an ERI interrupt request is issued to the CPU instead; the error flag must be cleared.

17.10 Usage Notes

17.10.1 Module Stop State Setting

Operation of the SCI can be disabled or enabled using the module stop control register. The initial setting is for operation of the SCI to be halted. Register access is enabled by clearing the module stop state. For details, see section 25, Power-Down Modes.

17.10.2 Break Detection and Processing

When framing error detection is performed, a break can be detected by reading the RxD pin value directly. In a break, the input from the RxD pin becomes all 0s, and so the FER flag is set, and the PER flag may also be set. Note that, since the SCI continues the receive operation even after receiving a break, even if the FER flag is cleared to 0, it will be set to 1 again.

17.10.3 Mark State and Break Detection

When the TE bit is 0, the TxD pin is used as an I/O port whose direction (input or output) and level are determined by DR and DDR. This can be used to set the TxD pin to mark state (high level) or send a break during serial data transmission. To maintain the communication line in mark state (the state of 1) until TE is set to 1, set both DDR and DR to 1. Since the TE bit is cleared to 0 at this point, the TxD pin becomes an I/O port, and 1 is output from the TxD pin. To send a break during serial transmission, first set DDR to 1 and DR to 0, and then clear the TE bit to 0. When the TE bit is cleared to 0, the transmitter is initialized regardless of the current transmission state, the TxD pin becomes an I/O port, and 0 is output from the TxD pin.

17.10.4 Receive Error Flags and Transmit Operations (Clock Synchronous Mode Only)

Transmission cannot be started when a receive error flag (ORER, FER, or RER) is set to 1, even if the TDRE flag is cleared to 0. Be sure to clear the receive error flags to 0 before starting transmission. Note also that the receive error flags cannot be cleared to 0 even if the RE bit is cleared to 0.

17.10.5 Relation between Writing to TDR and TDRE Flag

The TDRE flag in SSR is a status flag which indicates that transmit data has been transferred from TDR to TSR. When the SCI transfers data from TDR to TSR, the TDRE flag is set to 1.

Data can be written to TDR irrespective of the TDRE flag status. However, if new data is written to TDR when the TDRE flag is 0, that is, when the previous data has not been transferred to TSR yet, the previous data in TDR is lost. Be sure to write transmit data to TDR after verifying that the TDRE flag is set to 1.

17.10.6 Restrictions on Using DTC or DMAC

- When the external clock source is used as a synchronization clock, update TDR by the DMAC or DTC and wait for at least five $P\phi$ clock cycles before allowing the transmit clock to be input. If the transmit clock is input within four clock cycles after TDR modification, the SCI may malfunction (see Figure 17.38).
- When using the DMAC or DTC to read RDR, be sure to set the receive end interrupt (RXI) as the DTC or DMAC activation source.

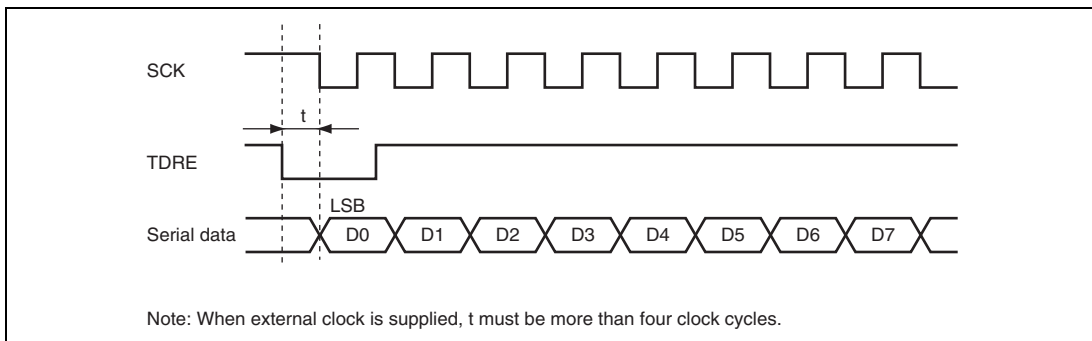

Figure 17.38 Sample Transmission using DTC in Clock Synchronous Mode

- The DTC is not activated by the RXI or TXI request by SCI₅ or SCI₆.

17.10.7 SCI Operations during Power-Down State

Transmission: Before specifying the module stop state or making a transition to software standby mode, stop the transmit operations ($TE = TIE = TEIE = 0$). TSR, TDR, and SSR are reset. The states of the output pins in the module stop state or in software standby mode depend on the port settings, and the pins output a high-level signal after cancellation. If the transition is made during data transmission, the data being transmitted will be undefined.

To transmit data in the same transmission mode after cancellation of the power-down state, set the TE bit to 1, read SSR, write to TDR, clear TDRE in this order, and then start transmission. To transmit data in a different transmission mode, initialize the SCI first.

Figure 17.39 shows a sample flowchart for transition to software standby mode during transmission. Figures 17.40 and 17.41 show the port pin states during transition to software standby mode.

Before specifying the module stop state or making a transition to software standby mode from the transmission mode using DTC transfer, stop all transmit operations ($TE = TIE = TEIE = 0$). Setting the TE and TIE bits to 1 after cancellation sets the TXI flag to start transmission using the DTC.

Reception: Before specifying the module stop state or making a transition to software standby mode, stop the receive operations ($RE = 0$). RSR, RDR, and SSR are reset. If transition is made during data reception, the data being received will be invalid.

To receive data in the same reception mode after cancellation of the power-down state, set the RE bit to 1, and then start reception. To receive data in a different reception mode, initialize the SCI first.

For using the IrDA function, set the IrE bit in addition to setting the RE bit.

Figure 17.42 shows a sample flowchart for mode transition during reception.

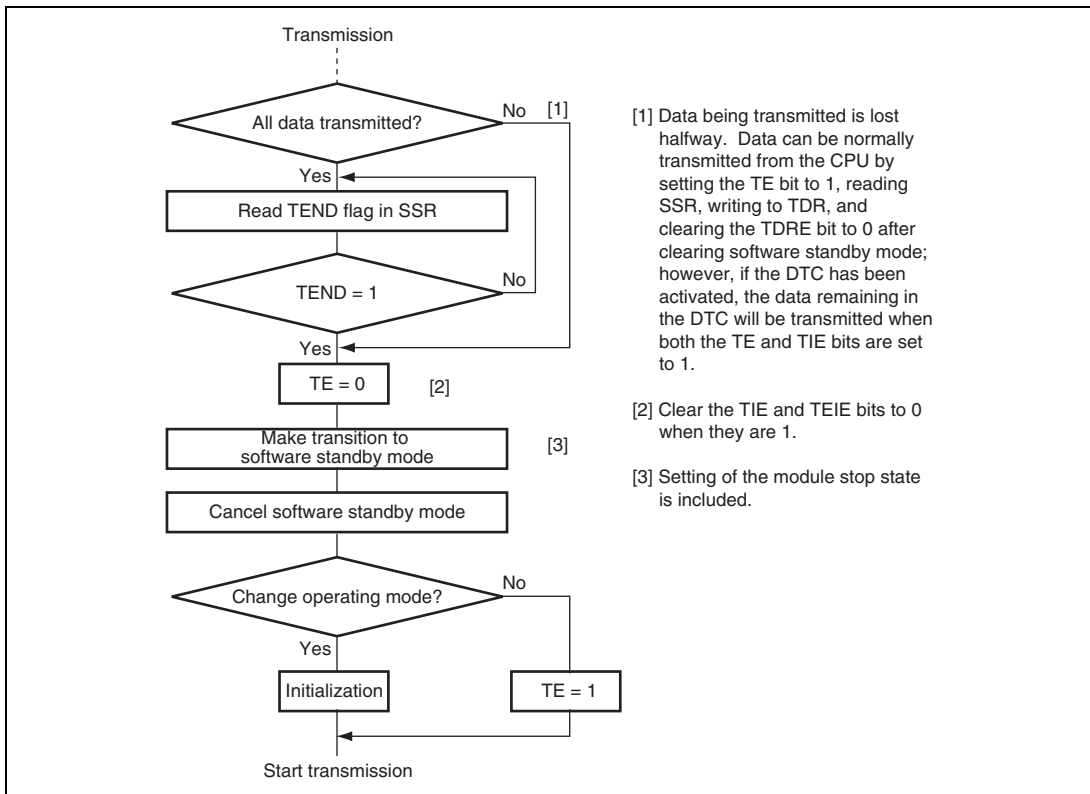

Figure 17.39 Sample Flowchart for Software Standby Mode Transition during Transmission

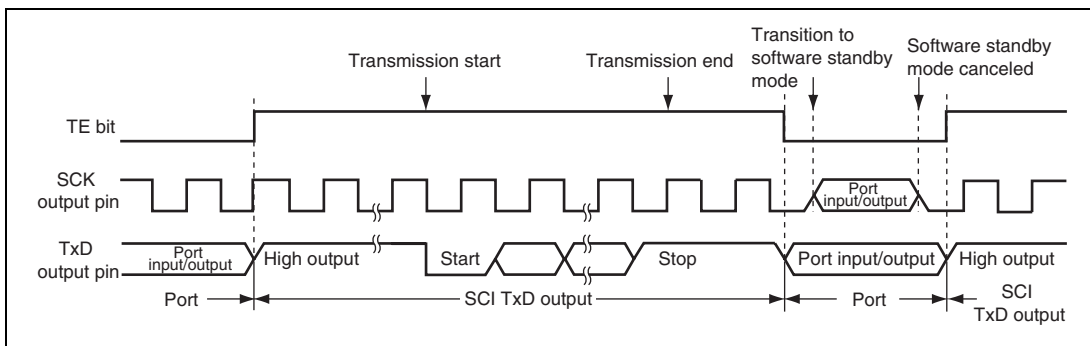

Figure 17.40 Port Pin States during Software Standby Mode Transition (Internal Clock, Asynchronous Transmission)

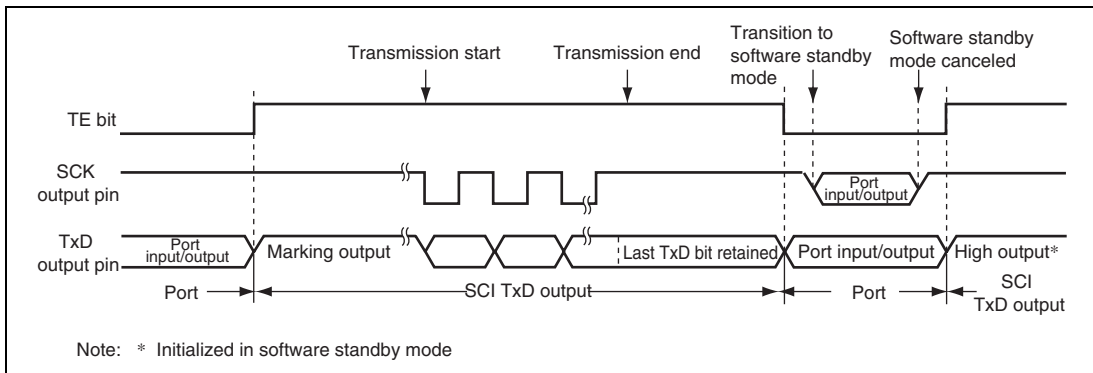

Figure 17.41 Port Pin States during Software Standby Mode Transition (Internal Clock, Clock Synchronous Transmission)

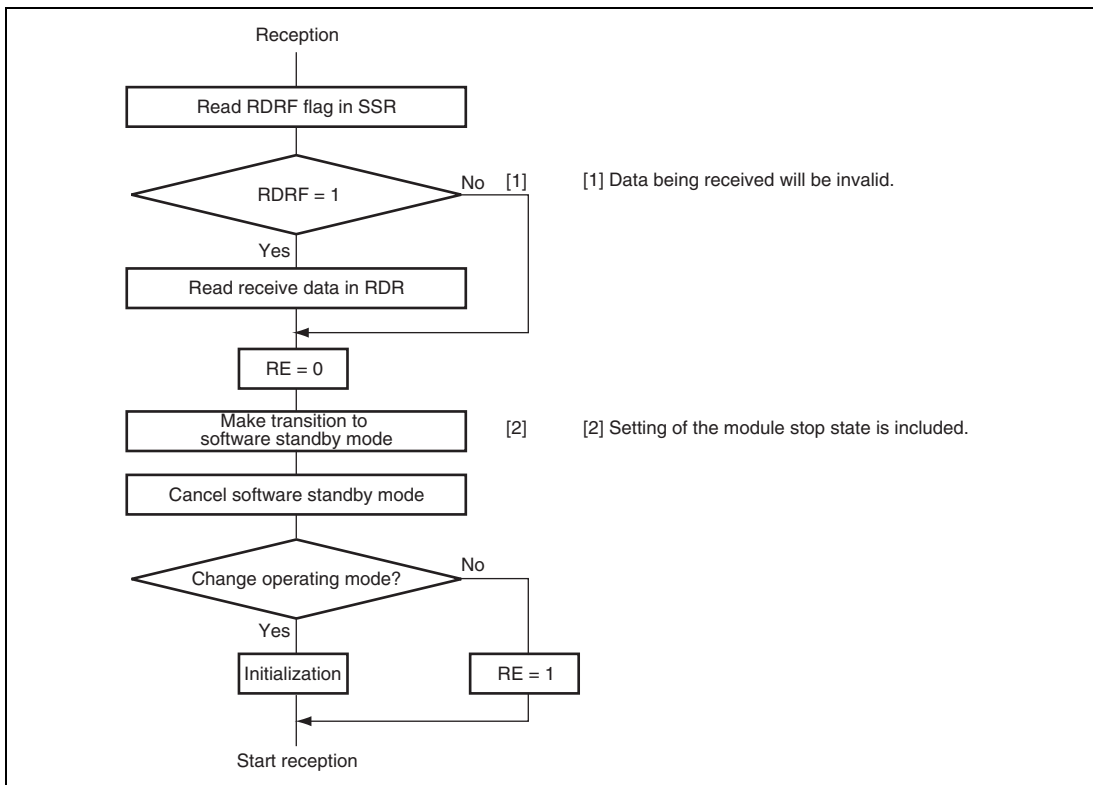

Figure 17.42 Sample Flowchart for Software Standby Mode Transition during Reception

17.11 CRC Operation Circuit

The cyclic redundancy check (CRC) operation circuit detects errors in data blocks.

17.11.1 Features

The features of the CRC operation circuit are listed below.

- CRC code generated for any desired data length in an 8-bit unit
- CRC operation executed on eight bits in parallel
- One of three generating polynomials selectable
- CRC code generation for LSB-first or MSB-first communication selectable

Figure 17.43 shows a block diagram of the CRC operation circuit.

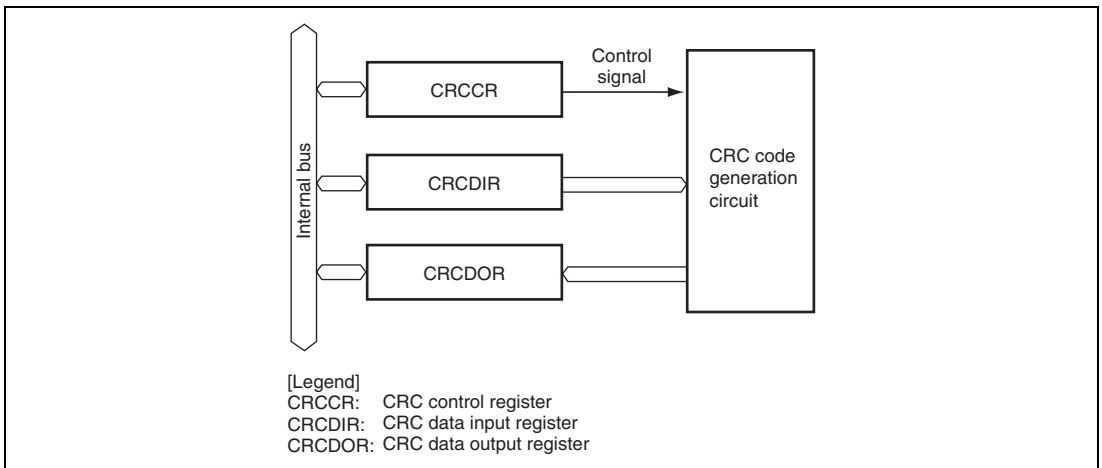

Figure 17.43 Block Diagram of CRC Operation Circuit

17.11.2 Register Descriptions

The CRC operation circuit has the following registers.

- CRC control register (CRCCR)
- CRC data input register (CRCDIR)
- CRC data output register (CRCDOR)

(1) CRC Control Register (CRCCR)

CRCCR initializes the CRC operation circuit, switches the operation mode, and selects the generating polynomial.

Bit	7	6	5	4	3	2	1	0
Bit Name	DORCLR	—	—	—	—	LMS	G1	G0
Initial Value	0	0	0	0	0	0	0	0
R/W	W	R	R	R	R	R/W	R/W	R/W

Bit	Bit Name	Initial Value	R/W	Description
7	DORCLR	0	W	CRCDOR Clear Setting this bit to 1 clears CRCDOR to H'0000.
6 to 3	—	All 0	R	Reserved The initial value should not be changed.
2	LMS	0	R/W	CRC Operation Switch Selects CRC code generation for LSB-first or MSB-first communication. 0: Performs CRC operation for LSB-first communication. The lower byte (bits 7 to 0) is first transmitted when CRCDOR contents (CRC code) are divided into two bytes to be transmitted in two parts. 1: Performs CRC operation for MSB-first communication. The upper byte (bits 15 to 8) is first transmitted when CRCDOR contents (CRC code) are divided into two bytes to be transmitted in two parts.

Bit	Bit Name	Initial Value	R/W	Description
1	G1	0	R/W	CRC Generating Polynomial Select:
0	G0	0	R/W	Selects the polynomial.
				00: Reserved
				01: $X^8 + X^2 + X + 1$
				10: $X^{16} + X^{15} + X^2 + 1$
				11: $X^{16} + X^{12} + X^5 + 1$

(2) CRC Data Input Register (CRCDIR)

CRCDIR is an 8-bit readable/writable register, to which the bytes to be CRC-operated are written. The result is obtained in CRCDOR.

Bit	7	6	5	4	3	2	1	0
Bit Name								
Initial Value	0	0	0	0	0	0	0	0
R/W	R/W	R/W	R/W	R/W	R/W	R/W	R/W	R/W

(3) CRC Data Output Register (CRCDOR)

CRCDOR is a 16-bit readable/writable register that contains the result of CRC operation when the bytes to be CRC-operated are written to CRCDIR after CRCDOR is cleared. When the CRC operation result is additionally written to the bytes to which CRC operation is to be performed, the CRC operation result will be H'0000 if the data contains no CRC error. When bits 1 and 0 in CRCCR (G1 and G0 bits) are set to 0 and 1, respectively, the lower byte of this register contains the result.

Bit	7	6	5	4	3	2	1	0
Bit Name								
Initial Value	0	0	0	0	0	0	0	0
R/W	R/W	R/W	R/W	R/W	R/W	R/W	R/W	R/W

Bit	7	6	5	4	3	2	1	0
Bit Name								
Initial Value	0	0	0	0	0	0	0	0
R/W	R/W	R/W	R/W	R/W	R/W	R/W	R/W	R/W

17.11.3 CRC Operation Circuit Operation

The CRC operation circuit generates a CRC code for LSB-first/MSB-first communications. An example in which a CRC code for hexadecimal data H'F0 is generated using the $X^{16} + X^{12} + X^5 + 1$ polynomial with the G1 and G0 bits in CRCCR set to B'11 is shown below.

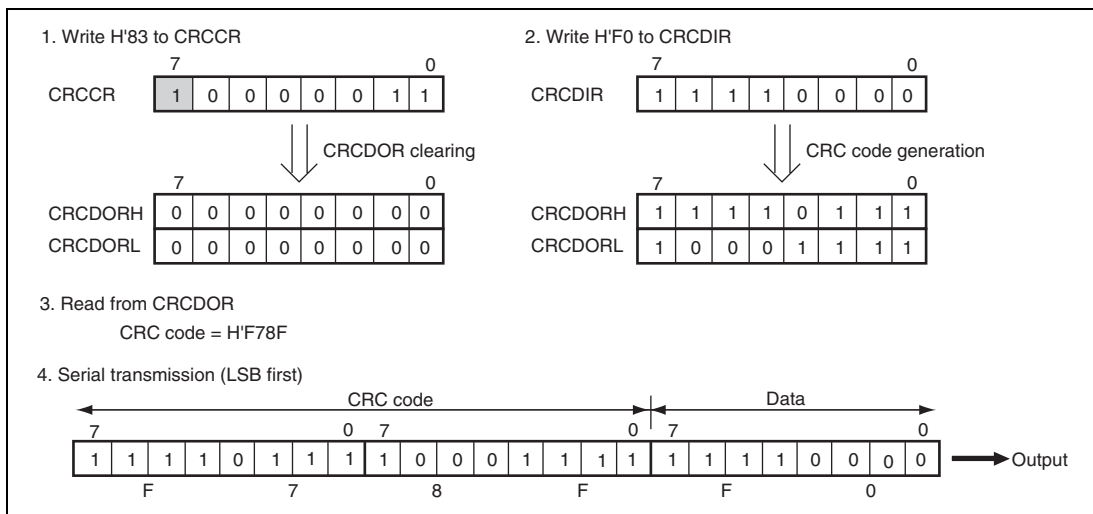

Figure 17.44 LSB-First Data Transmission

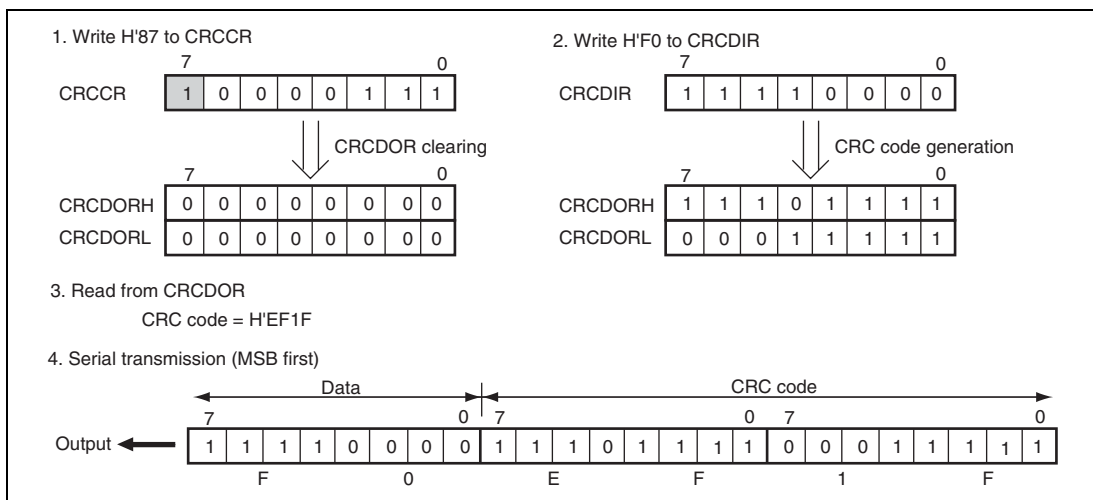
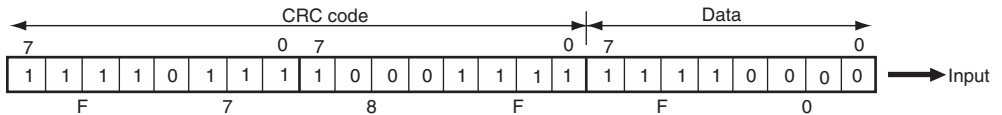
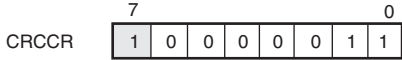

Figure 17.45 MSB-First Data Transmission

1. Serial reception (LSB first)



2. Write H'83 to CRCCR



CRCDOR clearing

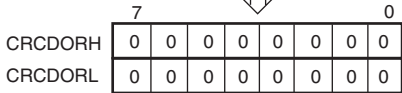

3. Write H'F0 to CRCDIR

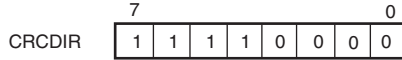

CRC code generation

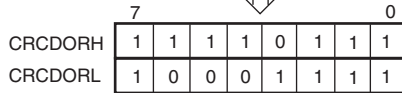

4. Write H'8F to CRCDIR

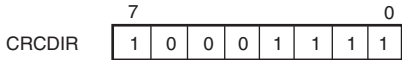

CRC code generation

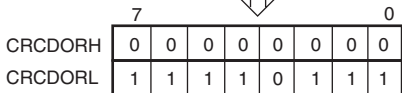

5. Write H'F7 to CRCDIR

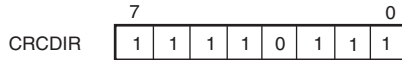

CRC code generation

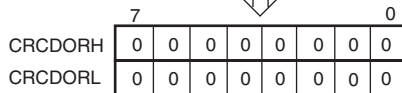

6. Read from CRCDOR

CRC code = H'0000 → No error

Figure 17.46 LSB-First Data Reception

1. Serial reception (MSB first)

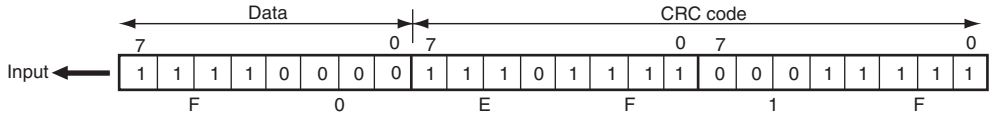

2. Write H'83 to CRCCR

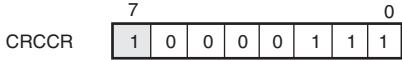

CRCDOR clearing

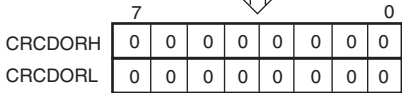

3. Write H'F0 to CRCDIR



CRC code generation



4. Write H'EF to CRCDIR

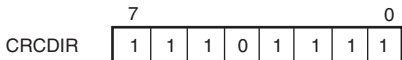

CRC code generation



5. Write H'1F to CRCDIR

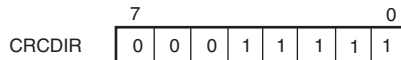

CRC code generation

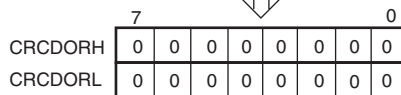

6. Read from CRCDOR

CRC code = H'0000 → No error

Figure 17.47 MSB-First Data Reception

17.11.4 Note on CRC Operation Circuit

Note that the sequence to transmit the CRC code differs between LSB-first transmission and MSB-first transmission.

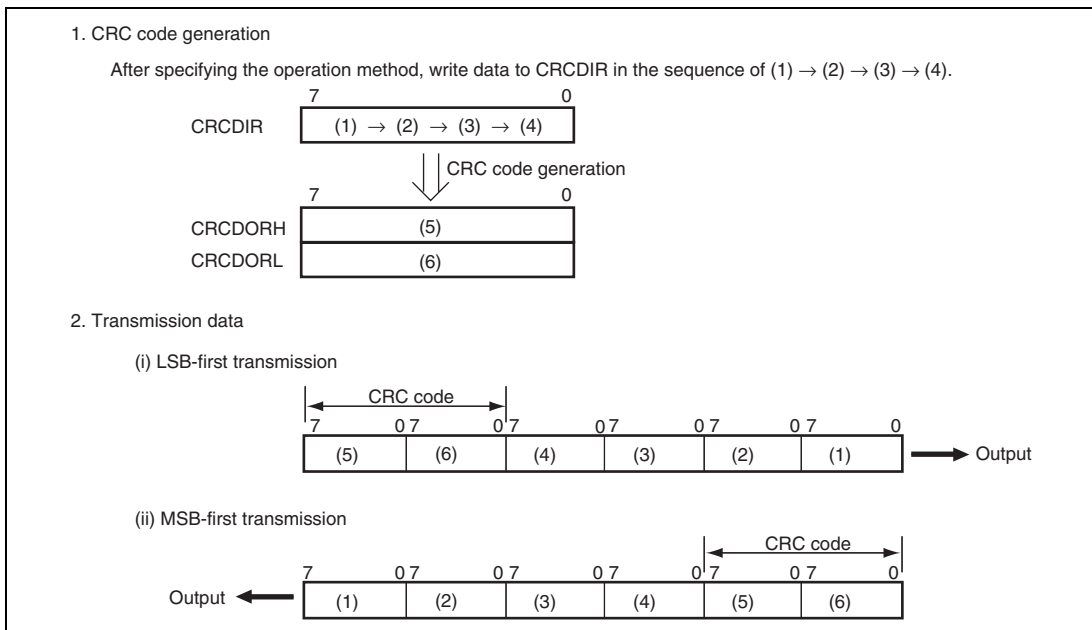

Figure 17.48 LSB-First and MSB-First Transmit Data

Section 18 I²C Bus Interface 2 (IIC2)

This LSI has a two-channel I²C bus interface.

The I²C bus interface conforms to and provides a subset of the Philips I²C bus (inter-IC bus) interface functions. The register configuration that controls the I²C bus differs partly from the Philips configuration, however.

Figure 18.1 shows the block diagram of the I²C bus interface 2.

Figure 18.2 shows an example of I/O pin connections to external circuits.

18.1 Features

- Continuous transmission/reception

Since the shift register, transmit data register, and receive data register are independent from each other, the continuous transmission/reception can be performed.

- Start and stop conditions generated automatically in master mode
- Selection of acknowledge output levels when receiving
- Automatic loading of acknowledge bit when transmitting
- Bit synchronization/wait function

In master mode, the state of SCL is monitored per bit, and the timing is synchronized automatically. If transmission or reception is not yet possible, drive the SCL signal low until preparations are completed

- Six interrupt sources

Transmit-data-empty (including slave-address match), transmit-end, receive-data-full (including slave-address match), arbitration lost, NACK detection, and stop condition detection

- Direct bus drive

Two pins, the SCL and SDA pins function as NMOS open-drain outputs.

- Module stop function setting

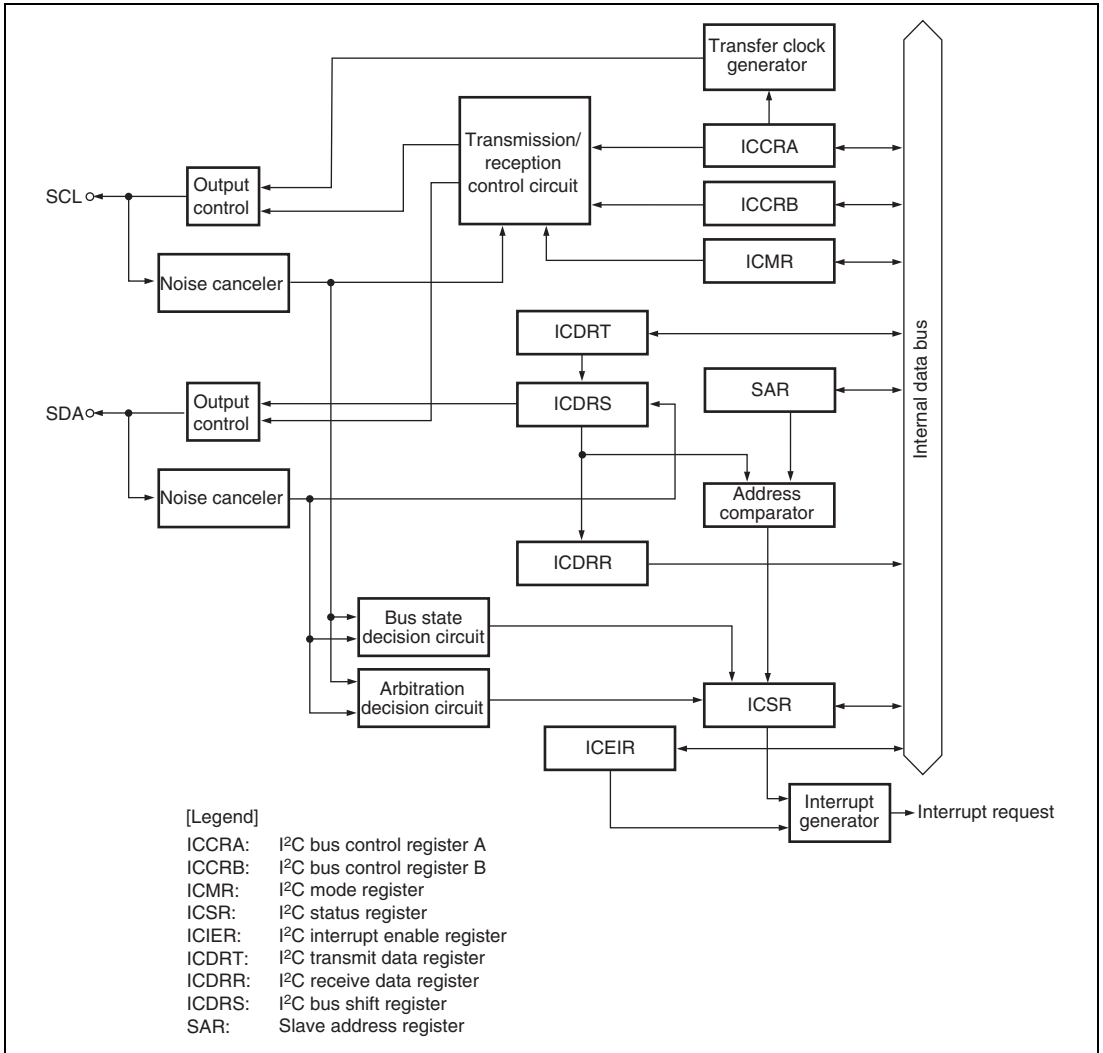

Figure 18.1 Block Diagram of I²C Bus Interface 2

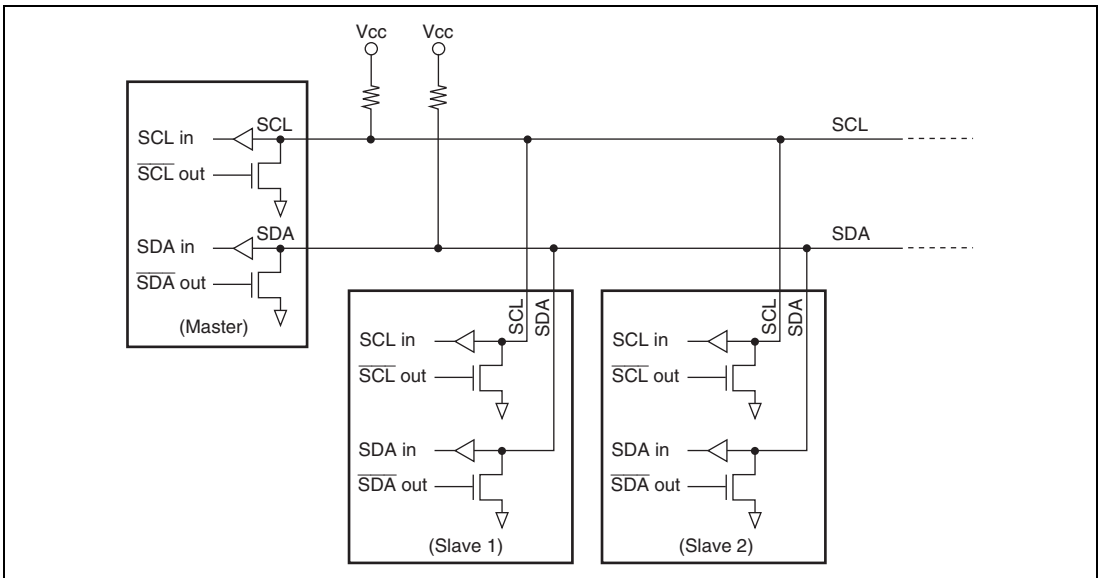

Figure 18.2 Connections to the External Circuit by the I/O Pins

18.2 Input/Output Pins

Table 18.1 shows the pin configuration of the I²C bus interface 2.

Table 18.1 Pin Configuration of the I²C Bus Interface 2

Channel	Abbreviation	I/O	Function
0	SCL0	I/O	Channel 0 serial clock I/O pin
	SDA0	I/O	Channel 0 serial data I/O pin
1	SCL1	I/O	Channel 1 serial clock I/O pin
	SDA1	I/O	Channel 1 serial data I/O pin

Note: The pin symbols are represented as SCL and SDA; channel numbers are omitted in this manual.

18.3 Register Descriptions

The I²C bus interface 2 has the following registers.

Channel 0:

- I²C bus control register A_0 (ICCRA_0)
- I²C bus control register B_0 (ICCRB_0)
- I²C bus mode register_0 (ICMR_0)
- I²C bus interrupt enable register_0 (ICIER_0)
- I²C bus status register_0 (ICSR_0)
- Slave address register_0 (SAR_0)
- I²C bus transmit data register_0 (ICDRT_0)
- I²C bus receive data register_0 (ICDRR_0)
- I²C bus shift register_0 (ICDRS_0)

Channel 1:

- I²C bus control register A_1 (ICCRA_1)
- I²C bus control register B_1 (ICCRB_1)
- I²C bus mode register_1 (ICMR_1)
- I²C bus interrupt enable register_1 (ICIER_1)
- I²C bus status register_1 (ICSR_1)
- Slave address register_1 (SAR_1)
- I²C bus transmit data register_1 (ICDRT_1)
- I²C bus receive data register_1 (ICDRR_1)
- I²C bus shift register_1 (ICDRS_1)

18.3.1 I²C Bus Control Register A (ICCRA)

ICCRA enables or disables I²C bus interface, controls transmission or reception, and selects master or slave mode, transmission or reception, and transfer clock frequency in master mode.

Bit	7	6	5	4	3	2	1	0
Bit Name	ICE	RCVD	MST	TRS	CKS3	CKS2	CKS1	CKS0
Initial Value	0	0	0	0	0	0	0	0
R/W	R/W	R/W	R/W	R/W	R/W	R/W	R/W	R/W

Bit	Bit Name	Initial Value	R/W	Description
7	ICE	0	R/W	I ² C Bus Interface Enable 0: This module is halted 1: This bit is enabled for transfer operations (SCL and SDA pins are bus drive state)
6	RCVD	0	R/W	Reception Disable This bit enables or disables the next operation when TRS is 0 and ICDRR is read. 0: Enables next reception 1: Disables next reception
5	MST	0	R/W	Master/Slave Select
4	TRS	0	R/W	Transmit/Receive Select When arbitration is lost in master mode, MST and TRS are both reset by hardware, causing a transition to slave receive mode. Modification of the TRS bit should be made between transfer frames. Operating modes are described below according to MST and TRS combination. 00: Slave receive mode 01: Slave transmit mode 10: Master receive mode 11: Master transmit mode
3	CKS3	0	R/W	Transfer Clock Select 3 to 0
2	CKS2	0	R/W	These bits are valid only in master mode. Make setting according to the required transfer rate. For details on the transfer rate, see table 18.2.
1	CKS1	0	R/W	
0	CKS0	0	R/W	

Table 18.2 Transfer Rate

Bit 3	Bit 2	Bit 1	Bit 0	Clock	Transfer Rate					
					P ϕ = 8 MHz	P ϕ = 10 MHz	P ϕ = 20 MHz	P ϕ = 25 MHz	P ϕ = 33 MHz	P ϕ = 35 MHz
0	0	0	0	P ϕ /28	286 kHz	357 kHz	714 kHz	893 kHz	1179 kHz	1250 kHz
			1	P ϕ /40	200 kHz	250 kHz	500 kHz	625 kHz	825 kHz	875 kHz
		1	0	P ϕ /48	167 kHz	208 kHz	417 kHz	521 kHz	688 kHz	729 kHz
			1	P ϕ /64	125 kHz	156 kHz	313 kHz	391 kHz	516 kHz	546 kHz
	1	0	0	P ϕ /168	47.6 kHz	59.5 kHz	119 kHz	149 kHz	196 kHz	208 kHz
			1	P ϕ /100	80.0 kHz	100 kHz	200 kHz	250 kHz	330 kHz	350 kHz
		1	0	P ϕ /112	71.4 kHz	89.3 kHz	179 kHz	223 kHz	295 kHz	312 kHz
			1	P ϕ /128	62.5 kHz	78.1 kHz	156 kHz	195 kHz	258 kHz	273 kHz
1	0	0	0	P ϕ /56	143 kHz	179 kHz	357 kHz	446 kHz	589 kHz	625 kHz
			1	P ϕ /80	100 kHz	125 kHz	250 kHz	313 kHz	413 kHz	437 kHz
		1	0	P ϕ /96	83.3 kHz	104 kHz	208 kHz	260 kHz	344 kHz	364 kHz
			1	P ϕ /128	62.5 kHz	78.1 kHz	156 kHz	195 kHz	258 kHz	273 kHz
	1	0	0	P ϕ /336	23.8 kHz	29.8 kHz	59.5 kHz	74.4 kHz	98.2 kHz	104 kHz
			1	P ϕ /200	40.0 kHz	50.0 kHz	100 kHz	125 kHz	165 kHz	175 kHz
		1	0	P ϕ /224	35.7 kHz	44.6 kHz	89.3 kHz	112 kHz	147 kHz	156 kHz
			1	P ϕ /256	31.3 kHz	39.1 kHz	78.1 kHz	97.7 kHz	129 kHz	136 kHz

18.3.2 I²C Bus Control Register B (ICCRB)

ICCRB issues start/stop condition, manipulates the SDA pin, monitors the SCL pin, and controls reset in the I²C control module.

Bit	7	6	5	4	3	2	1	0
Bit Name	BBSY	SCP	SDAO	—	SCLO	—	IICRST	—
Initial Value	0	1	1	1	1	1	0	1
R/W	R/W	R/W	R	R/W	R	—	R/W	—

Bit	Bit Name	Initial Value	R/W	Description
7	BBSY	0	R/W	<p>Bus Busy</p> <p>This bit indicates whether the I²C bus is occupied or released and to issue start and stop conditions in master mode. This bit is set to 1 when the SDA level changes from high to low under the condition of SCL = high, assuming that the start condition has been issued. This bit is cleared to 0 when the SDA level changes from low to high under the condition of SDA = high, assuming that the stop condition has been issued. Follow this procedure also when re-transmitting a start condition. To issue a start or stop condition, use the MOV instruction.</p>
6	SCP	1	R/W	<p>Start/Stop Condition Issue</p> <p>This bit controls the issuance of start or stop condition in master mode.</p> <p>To issue a start condition, write 1 to BBSY and 0 to SCP. A re-transmit start condition is issued in the same way. To issue a stop condition, write 0 to BBSY and 0 to SCP. This bit is always read as 1. If 1 is written, the data is not stored.</p>
5	SDAO	1	R	<p>This bit monitors the output level of SDA.</p> <p>0: When reading, the SDA pin outputs a low level 1: When reading the SDA pin outputs a high level</p>
4	—	1	R/W	<p>Reserved</p> <p>The write value should always be 1.</p>
3	SCLO	1	R	<p>This bit monitors the SCL output level.</p> <p>When reading and SCLO is 1, the SCL pin outputs a high level. When reading and SCLO is 0, the SCL pin outputs a low level.</p>
2	—	1	—	<p>Reserved</p> <p>This bit is always read as 0.</p>
1	IICRST	0	R/W	<p>IIC Control Module Reset</p> <p>This bit reset the IIC control module except the I²C registers. If hang-up occurs because of communication failure during I²C operation, by setting this bit to 1, the I²C control module can be reset without initializing the registers.</p>
0	—	1	—	<p>Reserved</p> <p>This bit is always read as 1.</p>

18.3.3 I²C Bus Mode Register (ICMR)

ICMR selects MSB first or LSB first, controls the master mode wait and selects the number of transfer bits.

Bit	7	6	5	4	3	2	1	0
Bit Name	—	WAIT	—	—	BCWP	BC2	BC1	BC0
Initial Value	0	0	1	1	1	0	0	0
R/W	R/W	R/W	—	—	R/W	R/W	R/W	R/W

Bit	Bit Name	Initial Value	R/W	Description
7	—	0	R/W	Reserved The write value should always be 0.
6	WAIT	0	R/W	Wait Insertion This bit selects whether to insert a wait after data transfer except for the acknowledge bit. When this bit is set to 1, after the falling of the clock for the last data bit, the low period is extended for two transfer clocks. When this bit is cleared to 0, data and the acknowledge bit are transferred consecutively with no waits inserted. The setting of this bit is invalid in slave mode.
5	—	1	—	Reserved
4	—	1	—	These bits are always read as 1.
3	BCWP	1	R/W	BC Write Protect This bit controls the modification of the BC2 to BC0 bits. When modifying, this bit should be cleared to 0 and the MOV instruction should be used. 0: When writing, the values of BC2 to BC0 are set 1: When reading, 1 is always read When writing, the settings of BC2 to BC0 are invalid.

Bit	Bit Name	Initial Value	R/W	Description	
2	BC2	0	R/W	Bit Counter 2 to 0	
1	BC1	0	R/W	These bits specify the number of bits to be transferred next. The settings of these bits should be made during intervals between transfer frames. When setting these bits to a value other than 000, the setting should be made while the SCL line is low. The value return to 000 at the end of a data transfer including the acknowledge bit.	
0	BC0	0	R/W		
					000: 9
					001: 2
					010: 3
					011: 4
					100: 5
					101: 6
				110: 7	
				111: 8	
				I ² C control module can be reset without setting the ports and initializing the registers.	

18.3.4 I²C Bus Interrupt Enable Register (ICIER)

ICIER enables or disables interrupt sources and the acknowledge bits, sets the acknowledge bits to be transferred, and confirms the acknowledge bit to be received.

Bit	7	6	5	4	3	2	1	0
Bit Name	TIE	TEIE	RIE	NAKIE	STIE	ACKE	ACKBR	ACKBT
Initial Value	0	0	0	0	0	0	0	0
R/W	R/W	R/W	R/W	R/W	R/W	R/W	R	R/W

Bit	Bit Name	Initial Value	R/W	Description
7	TIE	0	R/W	<p>Transmit Interrupt Enable</p> <p>When the TDRE bit in ICSR is set to 1, this bit enables or disables the transmit data empty interrupt (TXI) request.</p> <p>0: Transmit data empty interrupt (TXI) request is disabled</p> <p>1: Transmit data empty interrupt (TXI) request is enabled</p>
6	TEIE	0	R/W	<p>Transmit End Interrupt Enable</p> <p>This bit enables or disables the transmit end interrupt (TEI) request at the rising of the ninth clock while the TDRE bit in ICSR is set to 1. The TEI request can be canceled by clearing the TEND bit or the TEIE bit to 0.</p> <p>0: Transmit end interrupt (TEI) request is disabled</p> <p>1: Transmit end interrupt (TEI) request is enabled</p>
5	RIE	0	R/W	<p>Receive Interrupt Enable</p> <p>This bit enables or disables the receive full interrupt (RXI) request when receive data is transferred from ICDRS to ICRR and the RDRF bit in ICSR is set to 1. The RXI request can be canceled by clearing the RDRF or RIE bit to 0.</p> <p>0: Receive data full interrupt (RXI) request is disabled</p> <p>1: Receive data full interrupt (RXI) request is enabled</p>
4	NAKIE	0	R/W	<p>NACK Receive Interrupt Enable</p> <p>This bit enables or disables the NACK receive interrupt (NAKI) request when the NACKF and AL bits in ICSR are set to 1. The NAKI request can be canceled by clearing the NACKF or AL bit, or the NAKIE bit to 0.</p> <p>0: NACK receive interrupt (NAKI) request is disabled</p> <p>1: NACK receive interrupt (NAKI) request is enabled</p>

Bit	Bit Name	Initial Value	R/W	Description
3	STIE	0	R/W	<p>Stop Condition Detection Interrupt Enable</p> <p>0: Stop condition detection interrupt (STPI) request is disabled</p> <p>1: Stop condition detection interrupt (STPI) request is enabled</p>
2	ACKE	0	R/W	<p>Acknowledge Bit Decision Select</p> <p>0: The value of the acknowledge bit is ignored and continuous transfer is performed</p> <p>1: If the acknowledge bit is 1, continuous transfer is suspended</p>
1	ACKBR	0	R	<p>Receive Acknowledge</p> <p>In transmit mode, this bit stores the acknowledge data that are returned by the receive device. This bit cannot be modified.</p> <p>0: Receive acknowledge = 0</p> <p>1: Receive acknowledge = 1</p>
0	ACKBT	0	R/W	<p>Transmit Acknowledge</p> <p>In receive mode, this bit specifies the bit to be sent at the acknowledge timing.</p> <p>0: 0 is sent at the acknowledge timing</p> <p>1: 1 is sent at the acknowledge timing</p>

18.3.5 I²C Bus Status Register (ICSR)

ICSR confirms the interrupt request flags and status.

Bit	7	6	5	4	3	2	1	0
Bit Name	TDRE	TEND	RDRF	NACKF	STOP	AL	AAS	ADZ
Initial Value	0	0	0	0	0	0	0	0
R/W	R/W	R/W	R/W	R/W	R/W	R/W	R/W	R/W

Bit	Bit Name	Initial Value	R/W	Description
7	TDRE	0	R/W	Transmit Data Register Empty [Setting condition] <ul style="list-style-type: none"> • When data is transferred from ICDRT to ICDRS and ICDRT becomes empty • When the TRS bits are set • When the start (re-transmit included) condition has been issued • When switched from reception to transmission in slave mode [Clearing conditions] <ul style="list-style-type: none"> • When 0 is written to this bit after reading TDRE = 1 (When the CPU is used to clear this flag by writing 0 while the corresponding interrupt is enabled, be sure to read the flag after writing 0 to it.) • When data is written to ICDRT
6	TEND	0	R/W	Transmit End [Setting condition] <ul style="list-style-type: none"> • When the ninth clock of SCL rises while the TDRE flag is 1 [Clearing conditions] <ul style="list-style-type: none"> • When 0 is written to this bit after reading TEND = 1 (When the CPU is used to clear this flag by writing 0 while the corresponding interrupt is enabled, be sure to read the flag after writing 0 to it.) • When data is written to ICDRT

Bit	Bit Name	Initial Value	R/W	Description
5	RDRF	0	R/W	<p>Receive Data Register Full</p> <p>[Setting condition]</p> <ul style="list-style-type: none"> When receive data is transferred from ICDRS to ICDRR <p>[Clearing conditions]</p> <ul style="list-style-type: none"> When 0 is written to this bit after reading RDRF = 1 (When the CPU is used to clear this flag by writing 0 while the corresponding interrupt is enabled, be sure to read the flag after writing 0 to it.) When data is read from ICDRR
4	NACKF	0	R/W	<p>No Acknowledge Detection Flag</p> <p>[Setting condition]</p> <ul style="list-style-type: none"> When no acknowledge is detected from the receive device in transmission while the ACKF bit in ICIEP is set to 1 <p>[Clearing condition]</p> <ul style="list-style-type: none"> When 0 is written to this bit after reading NACKF = 1 (When the CPU is used to clear this flag by writing 0 while the corresponding interrupt is enabled, be sure to read the flag after writing 0 to it.)
3	STOP	0	R/W	<p>Stop Condition Detection Flag</p> <p>[Setting condition]</p> <ul style="list-style-type: none"> When a stop condition is detected after frame transfer <p>[Clearing condition]</p> <ul style="list-style-type: none"> When 0 is written to this bit after reading STOP = 1 (When the CPU is used to clear this flag by writing 0 while the corresponding interrupt is enabled, be sure to read the flag after writing 0 to it.)

Bit	Bit Name	Initial Value	R/W	Description
2	AL	0	R/W	<p>Arbitration Lost Flag</p> <p>This flag indicates that arbitration was lost in master mode.</p> <p>When two or more master devices attempt to seize the bus at nearly the same time, the I²C bus monitors SDA, and if the I²C bus interface detects data differing from the data it sent, it sets AL to 1 to indicate that the bus has been taken by another master.</p> <p>[Setting conditions]</p> <ul style="list-style-type: none"> When the internal SDA and the SDA pin level disagree at the rising of SCL in master transmit mode When the SDA pin outputs a high level in master mode while a start condition is detected <p>[Clearing condition]</p> <ul style="list-style-type: none"> When 0 is written to this bit after reading AL = 1 (When the CPU is used to clear this flag by writing 0 while the corresponding interrupt is enabled, be sure to read the flag after writing 0 to it.)
1	AAS	0	R/W	<p>Slave Address Recognition Flag</p> <p>In slave receive mode, this flag is set to 1 when the first frame following a start condition matches bits SVA6 to SVA0 in SAR.</p> <p>[Setting conditions]</p> <ul style="list-style-type: none"> When the slave address is detected in slave receive mode When the general call address is detected in slave receive mode <p>[Clearing condition]</p> <ul style="list-style-type: none"> When 0 is written to this bit after reading AAS = 1

Bit	Bit Name	Initial Value	R/W	Description
0	ADZ	0	R/W	<p>General Call Address Recognition Flag</p> <p>This bit is valid in slave receive mode.</p> <p>[Setting condition]</p> <ul style="list-style-type: none"> When the general call address is detected in slave receive mode <p>[Clearing condition]</p> <ul style="list-style-type: none"> When 0 is written to this bit after reading ADZ = 1

18.3.6 Slave Address Register (SAR)

SAR sets the slave address. In slave mode, if the upper 7 bits of SAR match the upper 7 bits of the first frame received after a start condition, the LSI operates as the slave device.

Bit	7	6	5	4	3	2	1	0
Bit Name	SVA6	SVA5	SVA4	SVA3	SVA2	SVA1	SVA0	—
Initial Value	0	0	0	0	0	0	0	0
R/W	R/W	R/W	R/W	R/W	R/W	R/W	R/W	R/W

Bit	Bit Name	Initial Value	R/W	Description
7 to 1	SVA6 to SVA0	0	R/W	<p>Slave Address 6 to 0</p> <p>These bits set a unique address differing from the addresses of other slave devices connected to the I²C bus.</p>
0	—	0	R/W	<p>Reserved</p> <p>Although this bit is readable/writable, only 0 should be written to.</p>

18.3.7 I²C Bus Transmit Data Register (ICDRT)

ICDRT is an 8-bit readable/writable register that stores the transmit data. When ICDRT detects a space in the I²C bus shift register, it transfers the transmit data which has been written to ICDRT to ICDRS and starts transmitting data. If the next data is written to ICDRT during transmitting data to ICDRS, continuous transmission is possible.

Bit	7	6	5	4	3	2	1	0
Bit Name								
Initial Value	0	0	0	0	0	0	0	0
R/W	R/W	R/W	R/W	R/W	R/W	R/W	R/W	R/W

18.3.8 I²C Bus Receive Data Register (ICDRR)

ICDRR is an 8-bit read-only register that stores the receive data. When one byte of data has been received, ICDRR transfers the receive data from ICDRS to ICDRR and the next data can be received. ICDRR is a receive-only register; therefore, this register cannot be written to by the CPU.

Bit	7	6	5	4	3	2	1	0
Bit Name								
Initial Value	0	0	0	0	0	0	0	0
R/W	R	R	R	R	R	R	R	R

18.3.9 I²C Bus Shift Register (ICDRS)

ICDRS is an 8-bit write-only register that is used to transmit/receive data. In transmission, data is transferred from ICDRT to ICDRS and the data is sent from the SDA pin. In reception, data is transferred from ICDRS to ICDRR after one byte of data is received. This register cannot be read from the CPU.

Bit	7	6	5	4	3	2	1	0
Bit Name								
Initial Value	0	0	0	0	0	0	0	0
R/W	W	W	W	W	W	W	W	W

18.4 Operation

18.4.1 I²C Bus Format

Figure 18.3 shows the I²C bus formats. Figure 18.4 shows the I²C bus timing. The first frame following a start condition always consists of 8 bits.

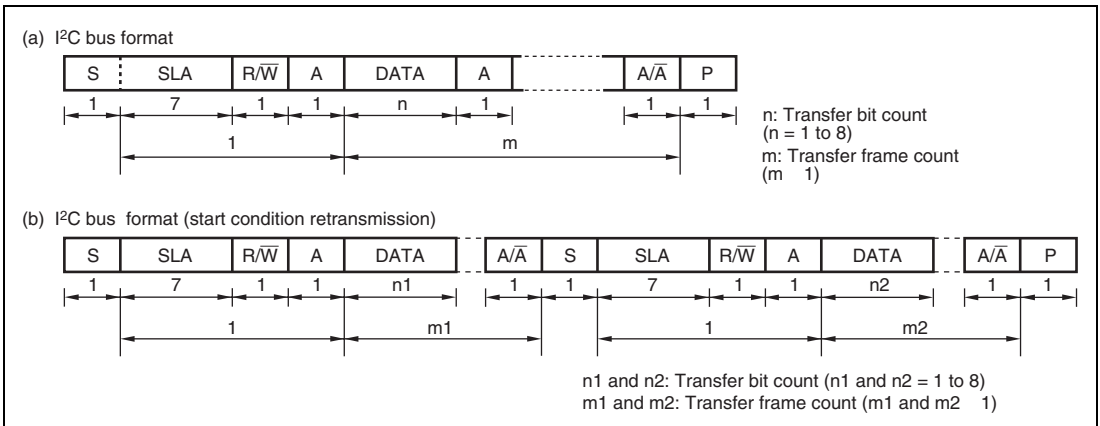

Figure 18.3 I²C Bus Formats

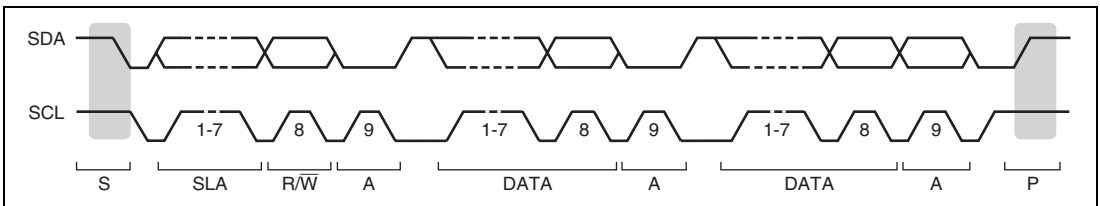

Figure 18.4 I²C Bus Timing

[Legend]

- S: Start condition. The master device drives SDA from high to low while SCL is high.
- SLA: Slave address
- R/W: Indicates the direction of data transfer; from the slave device to the master device when R/W is 1, or from the master device to the slave device when R/W is 0.
- A: Acknowledge. The receive device drives SDA low.
- DATA: Transferred data
- P: Stop condition. The master device drives SDA from low to high while SCL is high.

18.4.2 Master Transmit Operation

In I²C bus format master transmit mode, the master device outputs the transmit clock and transmit data, and the slave device return an acknowledge signal. Figures 18.5 and 18.6 show the operating timings in master transmit mode. The transmission procedure and operations in master transmit mode are described below.

1. Set the ICR bit in the corresponding register to 1. Set the ICE bit in ICCRA to 1. Set the WAIT bit in ICMR and the CKS3 to CKS0 bits in ICCRA to 1. (initial setting)
2. Read the BSSY flag in ICCRB to confirm that the bus is free. Set the MST and TRS bits in ICCRA to select master transmit mode. Then, write 1 to BBSY and 0 to SCP using the MOV instruction. (The start condition is issued.) This generates the start condition.
3. After confirming that TDRE in ICSR has been set, write the transmit data (the first byte shows the slave address and R/W) to ICDRT. After this, when TDRE is automatically cleared to 0, data is transferred from ICDRT to ICDRS. TDRE is set again.
4. When transmission of one byte data is completed while TDRE is 1, TEND in ICSR is set to 1 at the rising of the ninth transmit clock pulse. Read the ACKBR bit in ICIER to confirm that the slave device has been selected. Then, write the second byte data to ICDRT. When ACKBR is 1, the slave device has not been acknowledged, so issue a stop condition. To issue the stop condition, write 0 to BBSY and SCP using the MOV instruction. SCL is fixed to a low level until the transmit data is prepared or the stop condition is issued.
5. The transmit data after the second byte is written to ICDRT every time TDRE is set.
6. Write the number of bytes to be transmitted to ICDRT. Wait until TEND is set (the end of last byte data transmission) while TDRE is 1, or wait for NACK (NACKF in ICSR is 1) from the receive device while ACKE in ICIER is 1. Then, issue the stop condition to clear TEND or NACKF.
7. When the STOP bit in ICSR is set to 1, the operation returns to the slave receive mode.

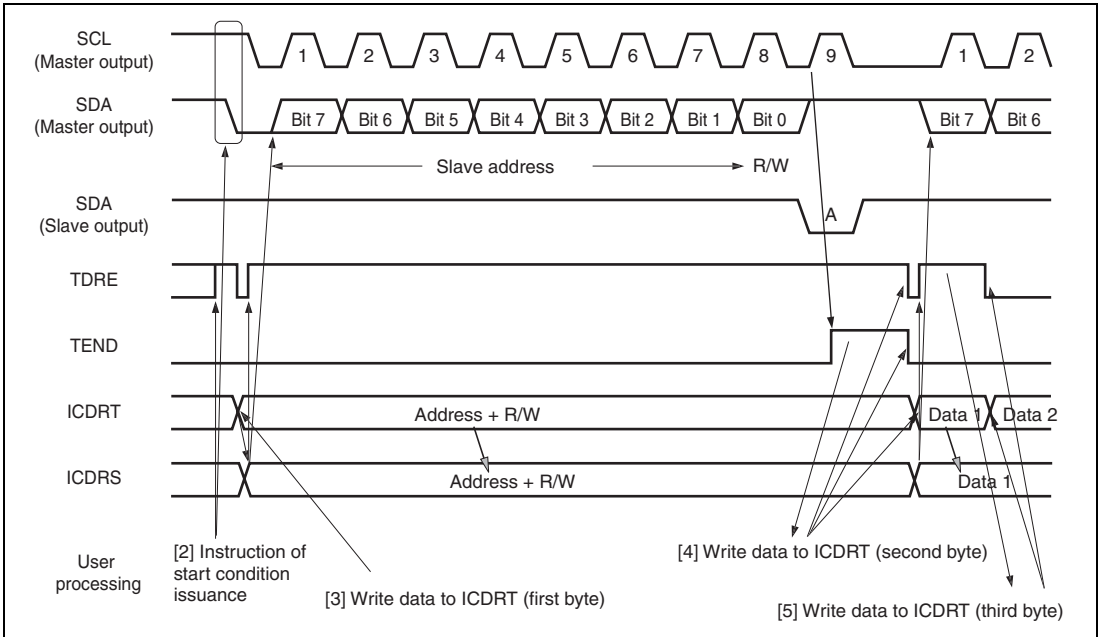

Figure 18.5 Master Transmit Mode Operation Timing 1

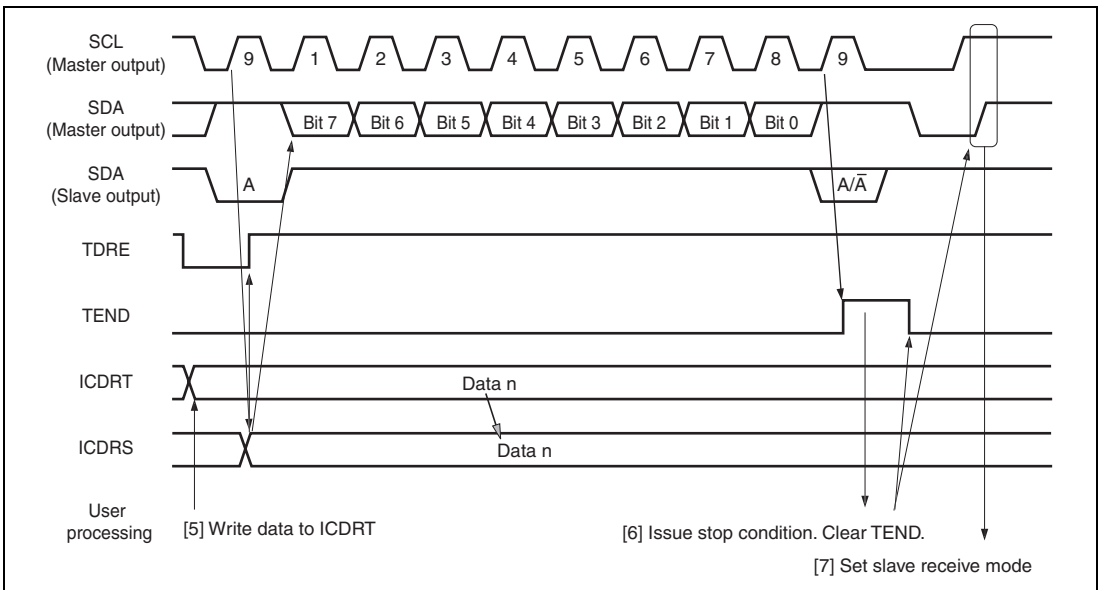

Figure 18.6 Master Transmit Mode Operation Timing 2

18.4.3 Master Receive Operation

In master receive mode, the master device outputs the receive clock, receives data from the slave device, and returns an acknowledge signal. Figures 18.7 and 18.8 show the operation timings in master receive mode. The reception procedure and operations in master receive mode are shown below.

1. Clear the TEND bit in ICSR to 0, then clear the TRS bit in ICCRA to 0 to switch from master transmit mode to master receive mode. Then, clear the TDRE bit to 0.
2. When ICDDR is read (dummy read), reception is started, the receive clock pulse is output, and data is received, in synchronization with the internal clock. The master mode outputs the level specified by the ACKBT in ICIER to SDA, at the ninth receive clock pulse.
3. After the reception of the first frame data is completed, the RDRF bit in ICSR is set to 1 at the rising of the ninth receive clock pulse. At this time, the received data is read by reading ICDRR. At the same time, RDRF is cleared.
4. The continuous reception is performed by reading ICDRR and clearing RDRF to 0 every time RDRF is set. If the eighth receive clock pulse falls after reading ICDRR by other processing while RDRF is 1, SCL is fixed to a low level until ICDRR is read.
5. If the next frame is the last receive data, set the RCVD bit in ICCRA before reading ICDRR. This enables the issuance of the stop condition after the next reception.
6. When the RDRF bit is set to 1 at the rising of the ninth receive clock pulse, the stop condition is issued.
7. When the STOP bit in ICSR is set to 1, read ICDRR and clear RCVD to 0.
8. The operation returns to the slave receive mode.

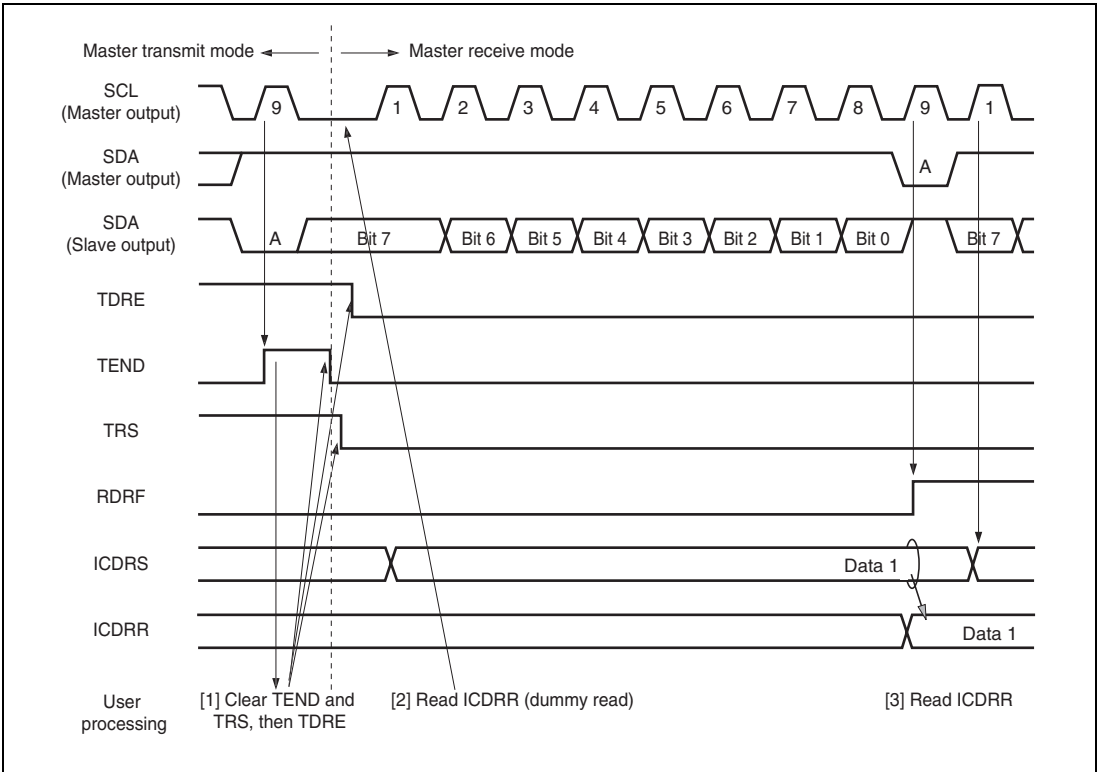

Figure 18.7 Master Receive Mode Operation Timing 1

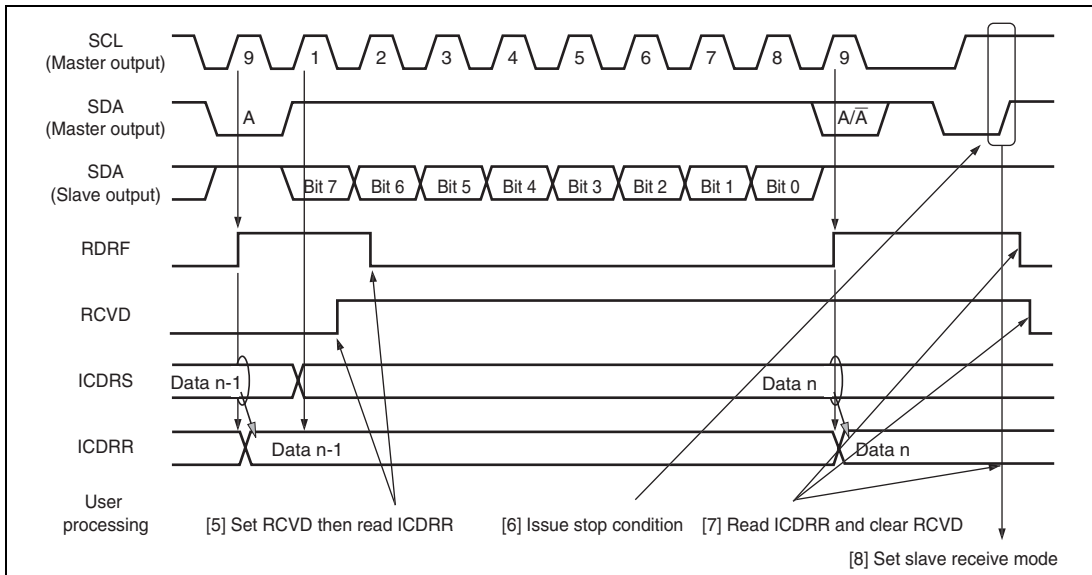

Figure 18.8 Master Receive Mode Operation Timing 2

18.4.4 Slave Transmit Operation

In slave transmit mode, the slave device outputs the transmit data, and the master device outputs the receive clock pulse and returns an acknowledge signal. Figures 18.9 and 18.10 show the operation timings in slave transmit mode. The transmission procedure and operations in slave transmit mode are described below.

1. Set the ICR bit in the corresponding register to 1, then set the ICE bit in ICCRA to 1. Set also the WAIT in ICMR, CKS3 to CKS0 in ICCRA, and others to perform initial settings. Set the MST and TRS bits in ICCRA to select slave receive mode, and wait until the slave address matches.
2. When the slave address matches in the first frame following the detection of the start condition, the slave device outputs the level specified by ACKBT in ICIER to SDA, at the rising of the ninth clock pulse. At this time, if the eighth bit data (R/W) is 1, TRS in ICCRA and TDRE in ICSR are set to 1, and the mode changes to slave transmit mode automatically. The continuous transmission is performed by writing the transmit data to ICDRT every time TDRE is set.
3. If TDRE is set after writing the last transmit data to ICDRT, wait until TEND in ICSR is set to 1, with TDRE = 1. When TEND is set, clear TEND.
4. Clear TRS for end processing, and read ICDRR (dummy read) to free SCL.
5. Clear TDRE.

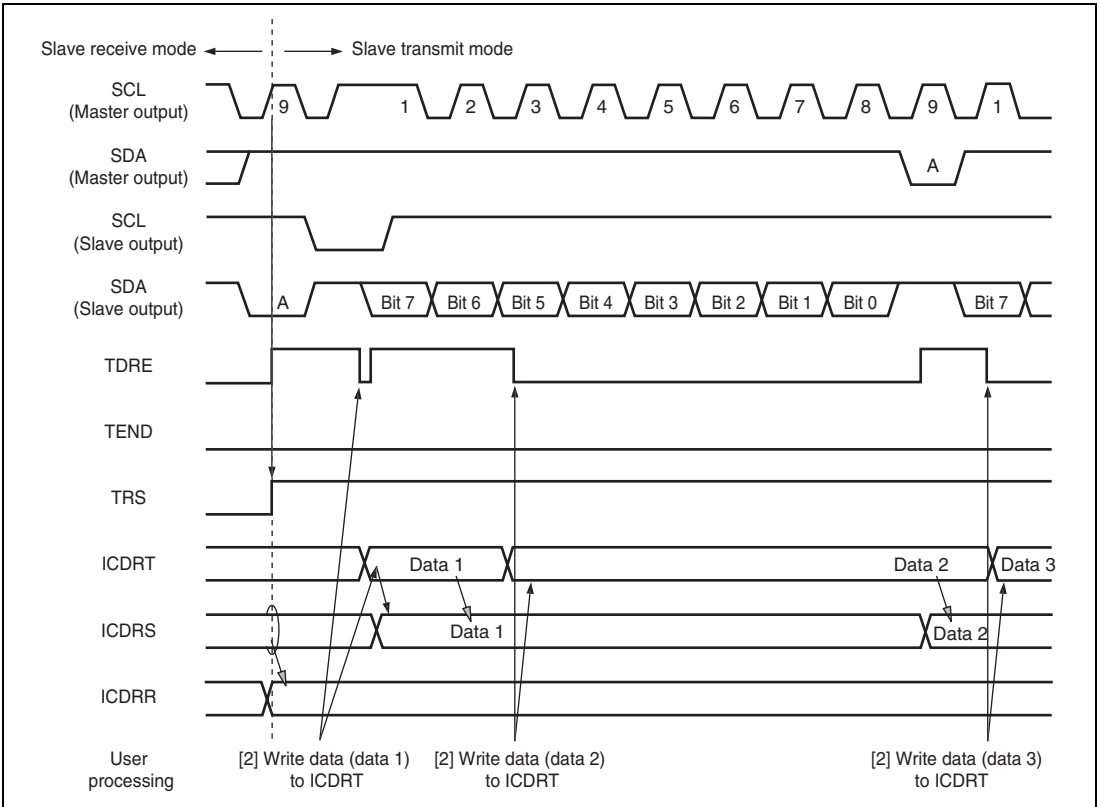

Figure 18.9 Slave Transmit Mode Operation Timing 1

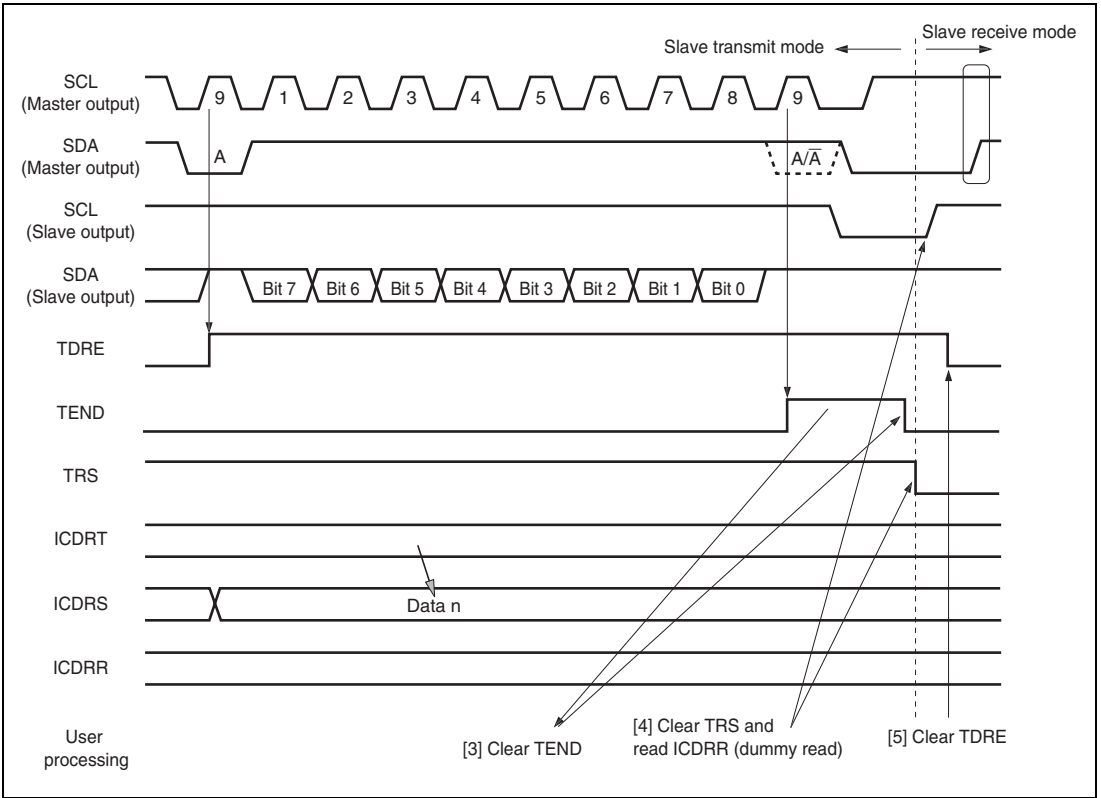

Figure 18.10 Slave Transmit Mode Operation Timing 2

18.4.5 Slave Receive Operation

In slave receive mode, the master device outputs the transmit clock and the transmit data, and the slave device returns an acknowledge signal. Figures 18.11 and 18.12 show the operation timings in slave receive mode. The reception procedure and operations in slave receive mode are described below.

1. Set the ICR bit in the corresponding register to 1. Then, set the ICE bit in ICCRA to 1. Set also the WAIT in ICMR, CKS3 to CKS0 in ICCRA, and others to perform initial settings. Set the MST and TRS bits in ICCRA to select slave receive mode and wait until the slave address matches.
2. When the slave address matches in the first frame following detection of the start condition, the slave address outputs the level specified by ACKBT in ICIER to SDA, at the rising of the ninth clock pulse. At the same time, RDRF in ICSR is set to read ICDRR (dummy read). (Since the read data shows the slave address and R/\bar{W} , it is not used).
3. Read ICDRR every time RDRF is set. If the eighth clock pulse falls while RDRF is 1, SCL is fixed to a low level until ICDRR is read. The change of the acknowledge (ACKBT) setting before reading ICDRR to be returned to the master device is reflected in the next transmit frame.
4. The last byte data is read by reading ICDRR.

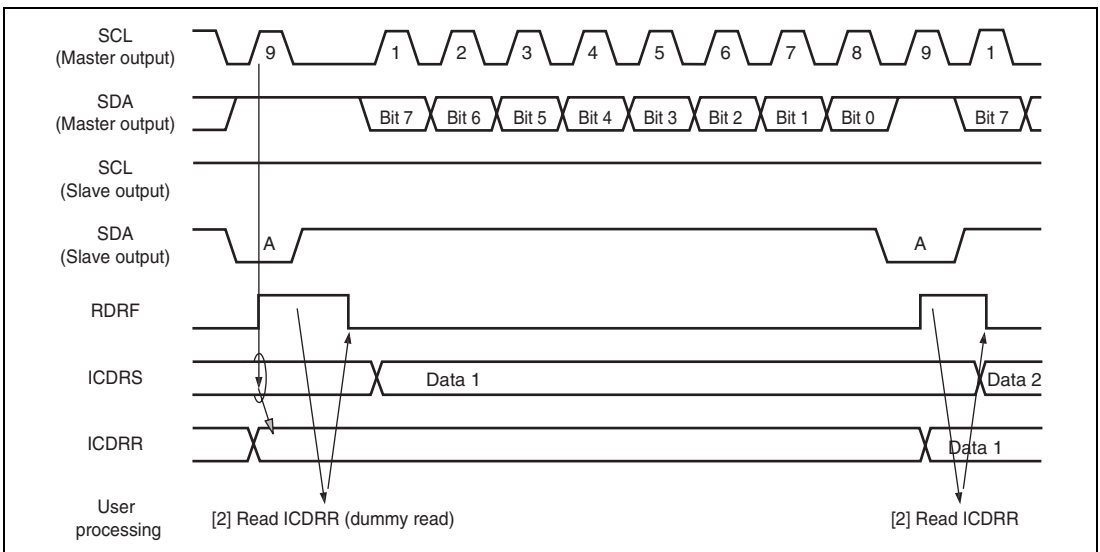

Figure 18.11 Slave Receive Mode Operation Timing 1

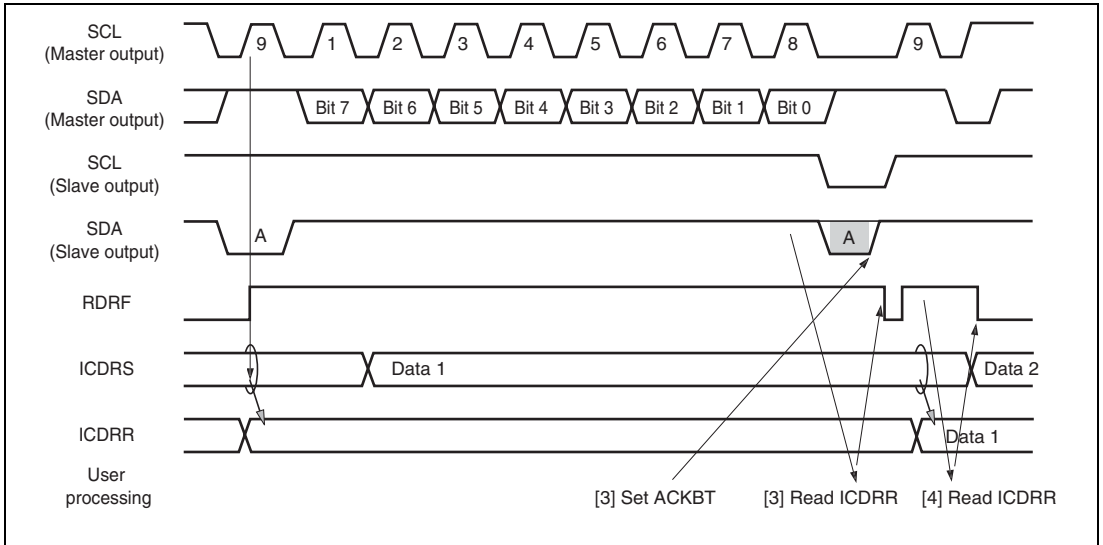

Figure 18.12 Slave Receive Mode Operation Timing 2

18.4.6 Noise Canceler

The logic levels at the SCL and SDA pins are routed through the noise cancelers before being latched internally. Figure 18.13 shows a block diagram of the noise canceler circuit.

The noise canceler consists of two cascaded latches and a match detector. The signal input to SCL (or SDA) is sampled on the system clock, but is not passed forward to the next circuit unless the outputs of both latches agree. If they do not agree, the previous value is held.

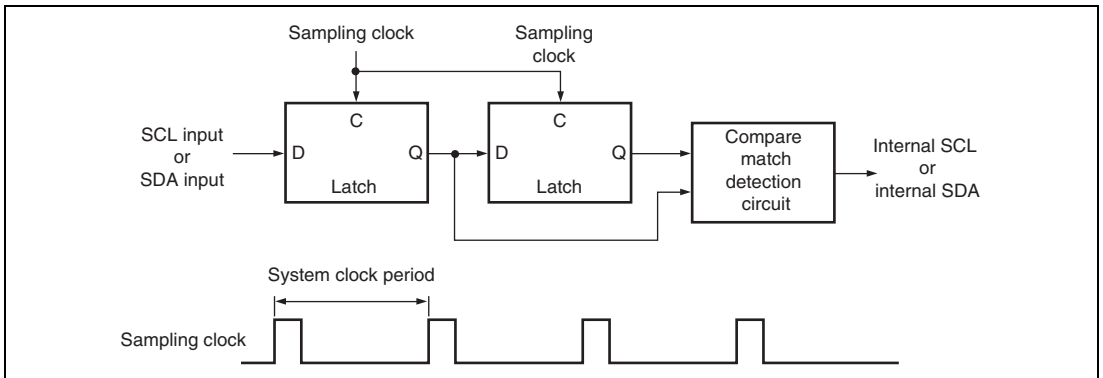

Figure 18.13 Block Diagram of Noise Canceler

18.4.7 Example of Use

Sample flowcharts in respective modes that use the I²C bus interface are shown in figures 18.14 to 18.17.

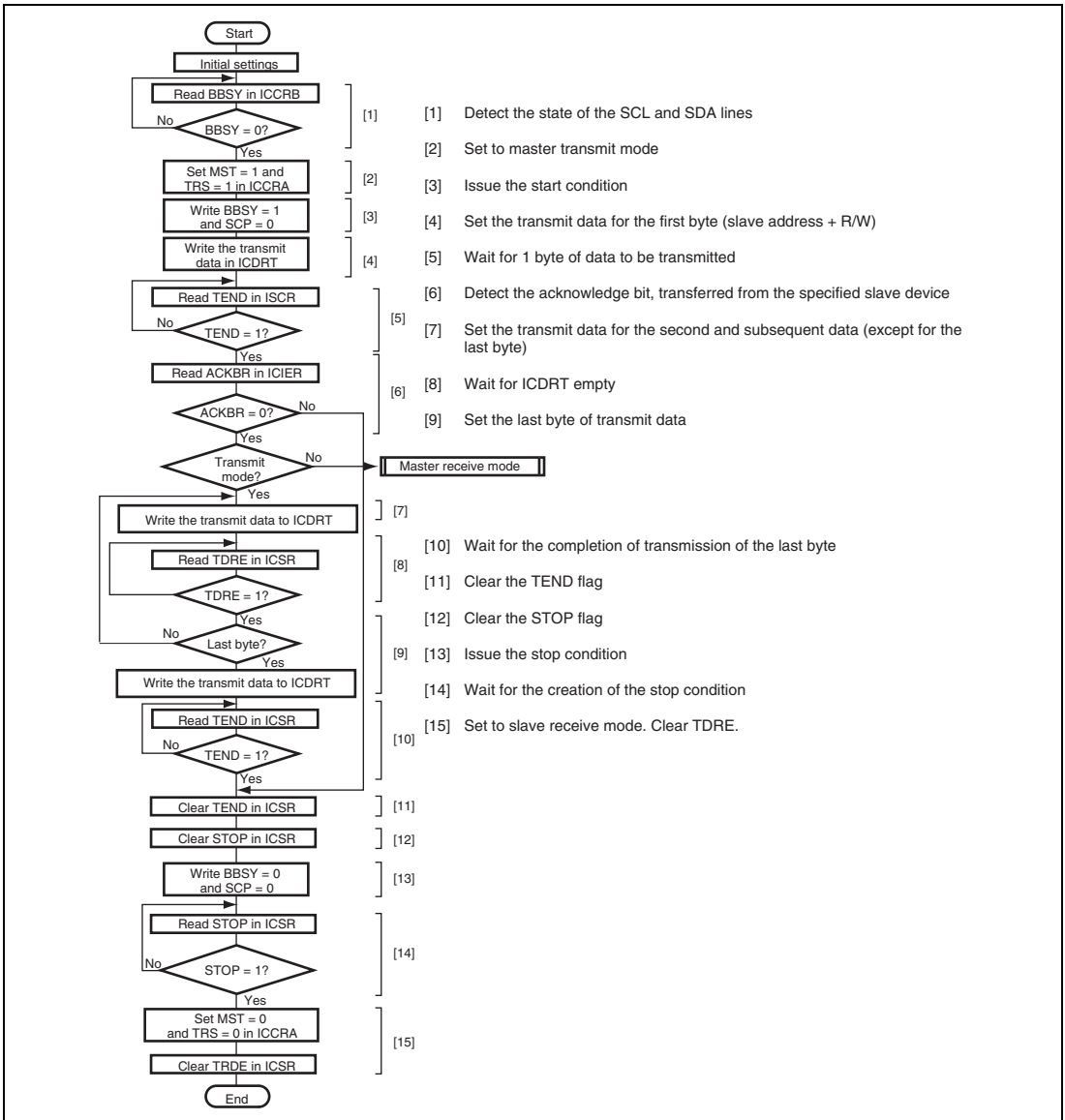
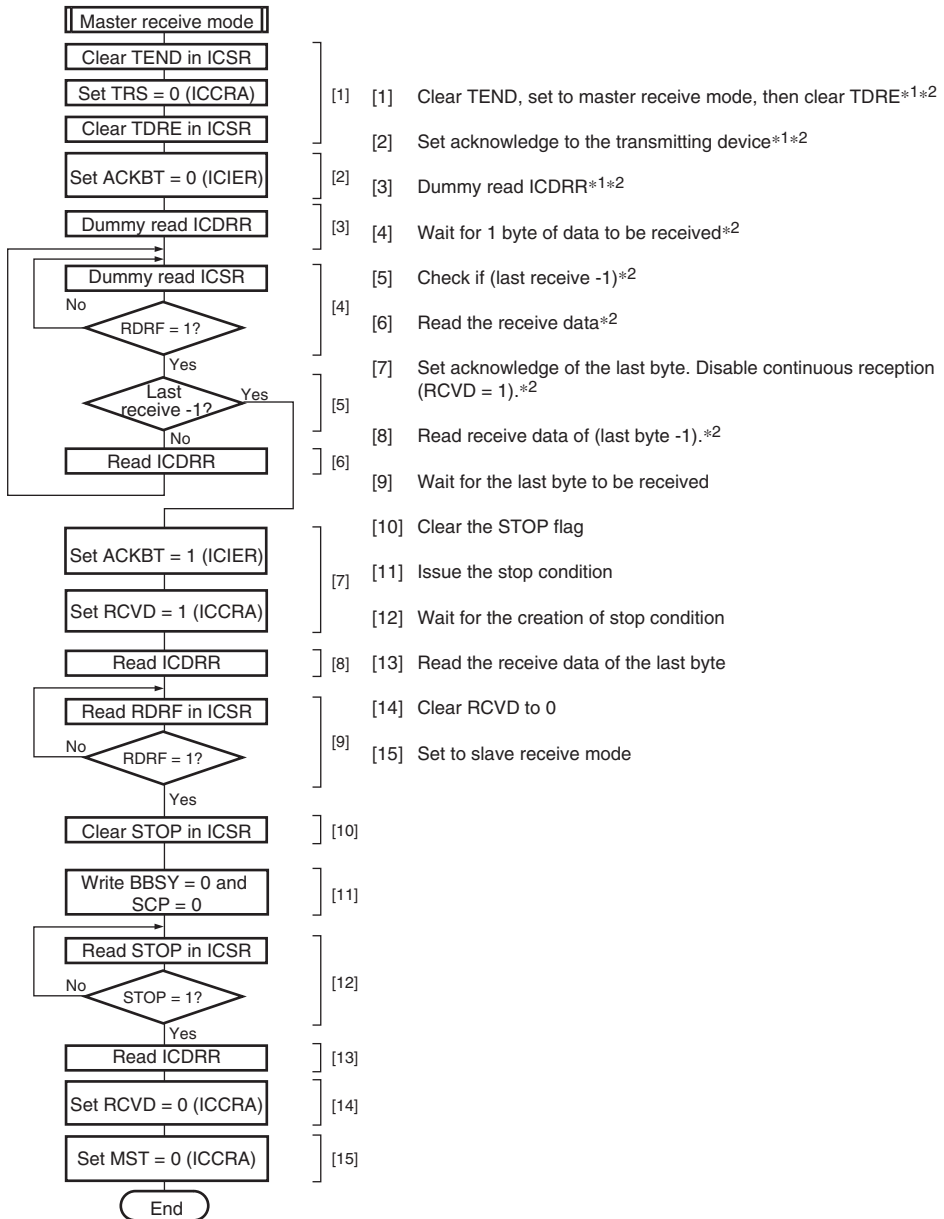

Figure 18.14 Sample Flowchart of Master Transmit Mode



Note: 1. Do not generate an interrupt during steps [1] to [3].
 2. For one-byte reception, steps [2] to [6] do not need to be executed. After step [1], execute step [7]. In step [8], read ICDRR (dummy read).

Figure 18.15 Sample Flowchart for Master Receive Mode

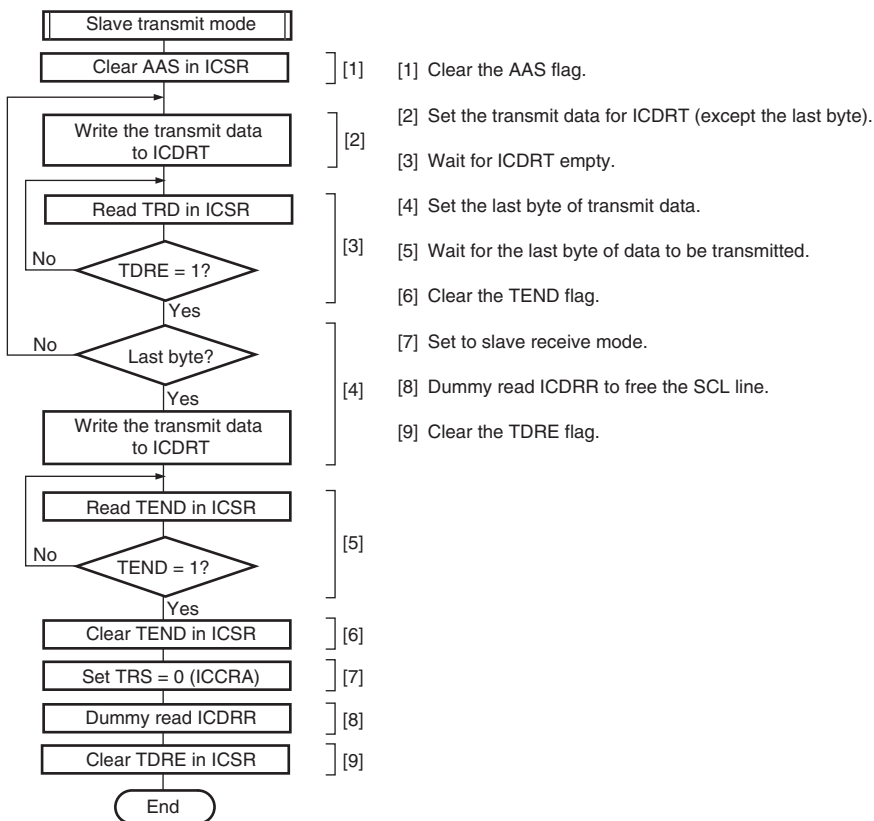
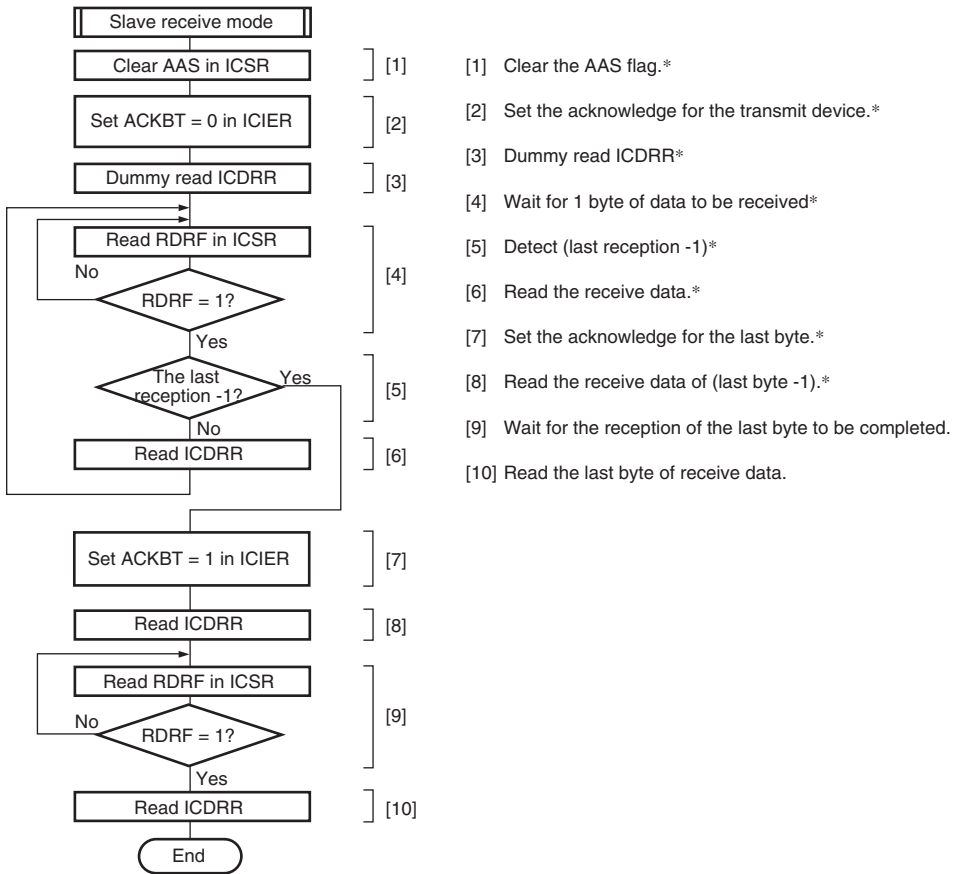

Figure 18.16 Sample Flowchart for Slave Transmit Mode



Note: * For one-byte reception, steps [2] to [6] do not need to be executed. After step [1], execute step [7].
 In step [8], read ICDRR (dummy read).

Figure 18.17 Sample Flowchart for Slave Receive Mode

18.5 Interrupt Request

There are six interrupt requests in this module; transmit data empty, transmit end, receive data full, NACK detection, STOP recognition, and arbitration lost. Table 18.3 shows the contents of each interrupt request.

Table 18.3 Interrupt Requests

Interrupt Request	Abbreviation	Interrupt Condition
Transmit Data Empty	TXI	$(TDRE = 1) \cdot (TIE = 1)$
Transmit End	TEI	$(TEND = 1) \cdot (TEIE = 1)$
Receive Data Full	RXI	$(RDRF = 1) \cdot (RIE = 1)$
Stop Recognition	STPI	$(STOP = 1) \cdot (STIE = 1)$
NACK Detection	NAKI	$\{(NACKF = 1) + (AL = 1)\} \cdot (NAKIE = 1)$
Arbitration Lost		

When one of the interrupt conditions in table 18.3 is 1 and the I bit in CCR is 0, the CPU executes interrupt exception handling. Clear the interrupt sources during interrupt exception handling. Note that the TDRE and TEND bits are automatically cleared to 0 by writing data to ICDRT, and the RDRF bit is cleared to 0 by reading ICDRR. In particular, the TDRE bit can be set again at the same time as data are for transmission written to ICDRT, and 1 extra byte can be transmitted if the TDRE is again cleared to 0.

18.6 Bit Synchronous Circuit

This module has a possibility that the high-level period is shortened in the two states described below.

In master mode,

- When SCL is driven low by the slave device
- When the rising speed of SCL is lowered by the load on the SCL line (load capacitance or pull-up resistance)

Therefore, this module monitors SCL and communicates bit by bit in synchronization.

Figure 18.18 shows the timing of the bit synchronous circuit, and table 18.4 shows the time when SCL output changes from low to Hi-Z and the period which SCL is monitored.

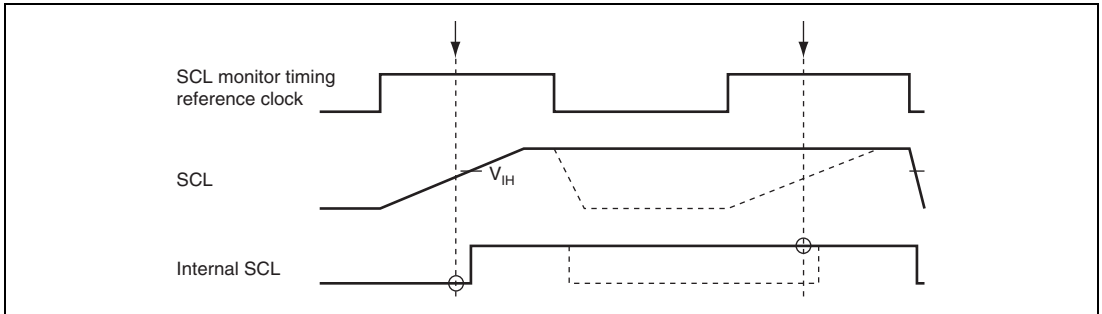

Figure 18.18 Timing of the Bit Synchronous Circuit

Table 18.4 Time for Monitoring SCL

CKS3	CKS2	Time for Monitoring SCL
0	0	7.5 t _{cy}
	1	19.5 t _{cy}
1	0	17.5 t _{cy}
	1	41.5 t _{cy}

18.7 Usage Notes

1. Confirm the ninth falling edge of the clock before issuing a stop or a repeated start condition. The ninth falling edge can be confirmed by monitoring the SCLO bit in the I²C bus control register B (ICCRB).

If a stop or a repeated start condition is issued at certain timing in either of the following cases, the stop or repeated start condition may be issued incorrectly.

- The rising time of the SCL signal exceeds the time given in section 18.6, Bit Synchronous Circuit, because of the load on the SCL bus (load capacitance or pull-up resistance).
- The bit synchronous circuit is activated because a slave device holds the SCL bus low during the eighth clock.

2. The WAIT bit in the I²C bus mode register (ICMR) must be held 0.

If the WAIT bit is set to 1, when a slave device holds the SCL signal low more than one transfer clock cycle during the eighth clock, the high level period of the ninth clock may be shorter than a given period.

3. Restriction in transfer rate setting value in multi-master mode

When the transfer rate of I²C transfer of this LSI is slower than that of other master, the SCL signal the width of which is unexpected may be output. To avoid this phenomenon, set a transfer rate of 1/1.8 or more of the fastest rate of other master to the transfer rate of I²C transfer rate. For example, if the fastest rate of other masters is 400 kbps, the I²C transfer rate of this LSI should be 223 kbps (= 400/1.8) or more.

4. Restriction in bit manipulation when the MST and TRS bits are set in multi-master mode

When the MST and TRS bits are set to master slave mode by manipulating these bits sequentially, the conflict state occurs as follows according to the timing that arbitration is lost; The AL bit in ICSR is set to 0, and set to master mode (MST = 1, TRS = 1). There are the following methods to avoid this phenomenon.

- In multi-master mode, set the MST and TRS bits by MOV instruction.
- When arbitration is lost, confirm that the MST and TRS bits are set to 0. If these bits are set to other than 0, set these bits to 0.

5. Notes on master receive mode

In master receive mode, the RDRF bit is set to 0 at the eighth rising clock, the SCL signal is pulled to “Low” state. When ICDRR is read near at the eighth falling clock, the SCL signal level is released and the ninth clock is outputted by fixing the eighth clock of receive data to “Low” state. Reading ICDRR is not required. As a result, the failure to receive data occurs. There are the following methods to avoid this phenomenon.

- In master receive mode, read ICDRR by the eighth rising clock.
- In master receive mode, set the RCVD bit to 1 and process the bit by the communication of every one byte.

6. Module stop function setting

Operation of the IIC2 can be disabled or enabled using the module stop control register. The initial setting is for operation of the IIC2 to be halted. Register access is enabled by clearing module stop state. For details, see section 25, Power-Down Modes.

Section 19 A/D Converter

This LSI includes two units (units 0 and 1) of successive approximation type 10-bit A/D converter. The A/D converter unit 0 allows up to eight analog input channels to be selected while the A/D converter unit 1 allows up to four analog input channels to be selected.

Figures 19.1 and 19.2 show block diagrams of the A/D converter units 0 and 1, respectively.

19.1 Features

- 10-bit resolution
- Eight or four input channels (total eight input channels for the two units)
 - Four channels x two units (for unit 0 and unit 1)
 - Eight channels x one unit (for unit 0)
- Conversion time: Unit 0: (2.7 μ s per channel)
 Unit 1: (2.7 μ s per channel)
- Two kinds of operating modes
 - Single mode: Single-channel A/D conversion
 - Scan mode: Continuous A/D conversion on 1 to 4 channels, or 1 to 8 channels*²
- Eight data registers for the A/D converter unit 0 and four data registers for unit 1 (total eight data registers for the two units)
 - Results of A/D conversion are held in a 16-bit data register for each channel.
- Sample and hold functionality
- Three types of conversion start
 - Conversion can be started by software, a conversion start trigger by the 16-bit timer pulse unit (TPU)*¹ or 8-bit timer (TMR)*², or an external trigger signal.
- Function of starting units simultaneously
 - A/D conversion for multiple units can be started by external trigger (ADTRG0).
- Interrupt source
 - A/D conversion end interrupt (ADI) request can be generated.
- Module stop state specifiable

Notes: 1. Only supported in the A/D converter unit 0.

2. For unit 0, A/D conversion can be started by a conversion start trigger by the TMR units 0 and 1 whereas for unit 1 A/D conversion can be started by a conversion start trigger by the TMR units 2 and 3.

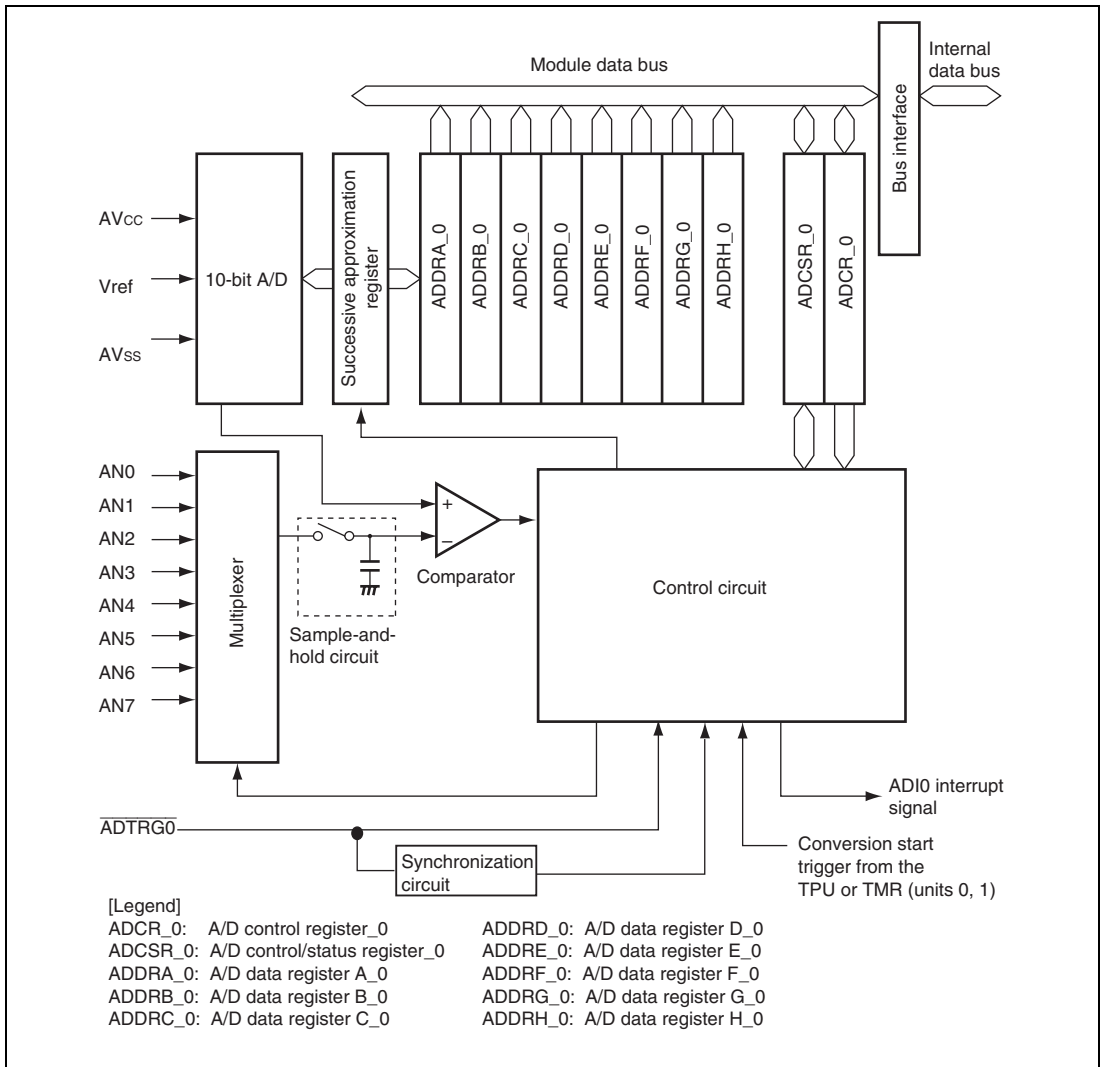

Figure 19.1 Block Diagram of A/D Converter Unit 0 (AD_0)

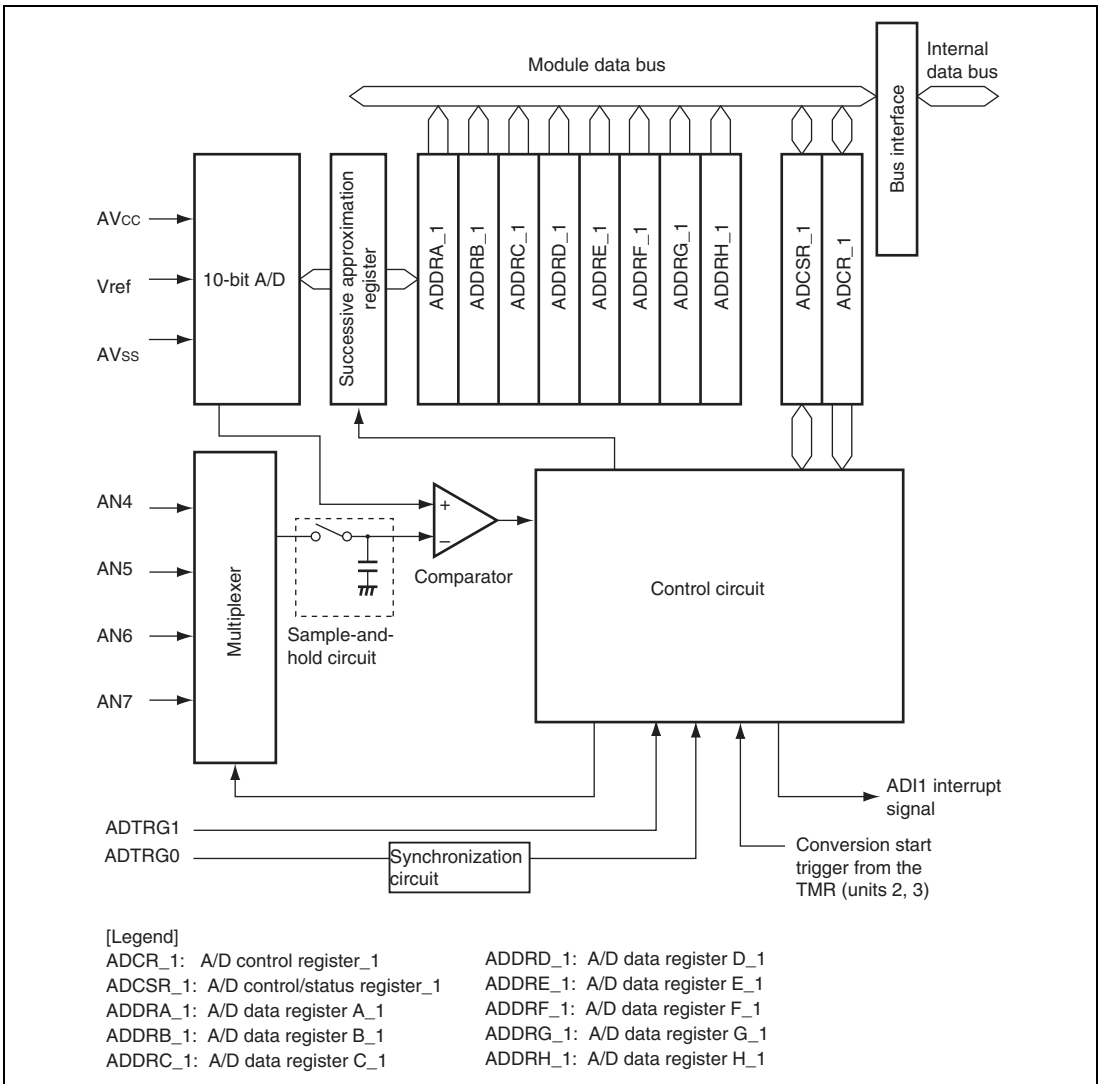

Figure 19.2 Block Diagram of A/D Converter Unit 1 (AD_1)

19.2 Input/Output Pins

Table 19.1 shows the pin configuration of the A/D converter.

Table 19.1 Pin Configuration

Unit	Abbr.	Pin Name	Symbol	I/O	Function	
0	AD_0	Analog input pin 0	AN0	Input	Analog inputs	
		Analog input pin 1	AN1	Input		
		Analog input pin 2	AN2	Input		
		Analog input pin 3	AN3	Input		
		Analog input pin 4	AN4	Input		
		Analog input pin 5	AN5	Input		
		Analog input pin 6	AN6	Input		
		Analog input pin 7	AN7	Input		
		A/D external trigger input pin 0	ADTRG0	Input		External trigger input for starting A/D conversion*
1	AD_1	Analog input pin 4	AN4	Input	Analog inputs	
		Analog input pin 5	AN5	Input		
		Analog input pin 6	AN6	Input		
		Analog input pin 7	AN7	Input		
		A/D external trigger input pin 0	ADTRG0	Input		External trigger input pin for starting A/D conversion*
		A/D external trigger input pin 1	ADTRG1	Input		External trigger input pin for starting A/D conversion*
Common		Analog power supply pin	AV _{CC}	Input	Analog block power supply	
		Analog ground pin	AV _{SS}	Input	Analog block ground	
		Reference voltage pin	Vref	Input	A/D conversion reference voltage	

Note: * Selectable by setting of the TRGS1, TRGS0, and EXTRGS bits in ADCR.

19.3 Register Descriptions

The A/D converter has the following registers.

Unit 0 (A/D_0) registers

- A/D data register A_0 (ADDRA_0)
- A/D data register B_0 (ADDRB_0)
- A/D data register C_0 (ADDRC_0)
- A/D data register D_0 (ADDRD_0)
- A/D data register E_0 (ADDRE_0)
- A/D data register F_0 (ADDRF_0)
- A/D data register G_0 (ADDRG_0)
- A/D data register H_0 (ADDRH_0)
- A/D control/status register_0 (ADCSR_0)
- A/D control register_0 (ADCR_0)

Unit 1 (A/D_1) registers

- A/D data register A_1 (ADDRA_1)
- A/D data register B_1 (ADDRB_1)
- A/D data register C_1 (ADDRC_1)
- A/D data register D_1 (ADDRD_1)
- A/D data register E_1 (ADDRE_1)
- A/D data register F_1 (ADDRF_1)
- A/D data register G_1 (ADDRG_1)
- A/D data register H_1 (ADDRH_1)
- A/D control/status register_1 (ADCSR_1)
- A/D control register_1 (ADCR_1)

19.3.1 A/D Data Registers A to H (ADDRA to ADDRH)

There are eight 16-bit read-only ADDR registers, ADDRA to ADDRH, used to store the results of A/D conversion. The ADDR registers, which store a conversion result for each channel, are shown in table 19.2.

The converted 10-bit data is stored in bits 15 to 6. The lower 6-bit data is always read as 0.

The data bus between the CPU and the A/D converter has a 16-bit width. The data can be read directly from the CPU. ADDR must not be accessed in 8-bit units and must be accessed in 16-bit units.

Bit	15	14	13	12	11	10	9	8	7	6	5	4	3	2	1	0
Bit Name											—	—	—	—	—	—
Initial Value	0	0	0	0	0	0	0	0	0	0	0	0	0	0	0	0
R/W	R	R	R	R	R	R	R	R	R	R	R	R	R	R	R	R

Table 19.2 Analog Input Channels and Corresponding ADDR Registers

Analog Input Channel	A/D Data Register Storing Conversion Result	
	Unit 0	Unit 1 * ²
AN0	ADDRA_0 (Unit 0)	—
AN1	ADDRB_0 (Unit 0)	—
AN2	ADDRC_0 (Unit 0)	—
AN3	ADDRD_0 (Unit 0)	—
AN4	ADDRE_0 (Unit 0) * ¹	ADDRE_1 (Unit 1) * ¹
AN5	ADDRF_0 (Unit 0) * ¹	ADDRF_1 (Unit 1) * ¹
AN6	ADDRG_0 (Unit 0) * ¹	ADDRG_1 (Unit 1) * ¹
AN7	ADDRH_0 (Unit 0) * ¹	ADDRH_1 (Unit 1) * ¹

Notes: 1. A/D conversion should be not performed on the same channel by multiple units.
 2. The ADDRA_1 to ADDRD_1 registers for unit 1 are not used.

19.3.2 A/D Control/Status Register for Unit 0 (ADCSR_0)

ADCSR_0 controls A/D conversion operations.

Bit	7	6	5	4	3	2	1	0
Bit Name	ADF	ADIE	ADST	-	CH3	CH2	CH1	CH0
Initial Value	0	0	0	0	0	0	0	0
R/W	R/(W)*	R/W	R/W	R/W	R/W	R/W	R/W	R/W

Note: * Only 0 can be written to this bit, to clear the flag.

Bit	Bit Name	Initial Value	R/W	Description
7	ADF	0	R/(W)*	<p>A/D end flag</p> <p>A status flag that indicates the end of A/D conversion.</p> <p>[Setting conditions]</p> <ul style="list-style-type: none"> Completion of A/D conversion in single mode Completion of A/D conversion on all specified channels in scan mode <p>[Clearing conditions]</p> <ul style="list-style-type: none"> Writing of 0 after reading ADF = 1 (When the CPU is used to clear this flag by writing 0 while the corresponding interrupt is enabled, be sure to read the flag after writing 0 to it.) Reading from ADDR after activation of the DMAC or DTC by an ADI interrupt
6	ADIE	0	R/W	<p>A/D interrupt enable</p> <p>Setting this bit to 1 enables ADI interrupts by ADF.</p>
5	ADST	0	R/W	<p>A/D start</p> <p>Clearing this bit to 0 stops A/D conversion, and the A/D converter enters wait state.</p> <p>Setting this bit to 1 starts A/D conversion. In single mode, this bit is cleared to 0 automatically when A/D conversion on the specified channel ends. In scan mode, A/D conversion continues sequentially on the specified channels until this bit is cleared to 0 by software, a reset, or hardware standby mode.</p> <p>Note: Do not write to ADST when activation is by an external trigger. For details, see section 19.7.3, Notes on A/D Activation by an External Trigger.</p>
4	—	0	R/W	<p>Reserved</p> <p>This bit is always read as 0. The write value should always be 0.</p>

Bit	Bit Name	Initial Value	R/W	Description
3	CH3	0	R/W	Channel select 3 to 0
2	CH2	0	R/W	Selects analog input together with bits SCANE and SCANS in ADCR.
1	CH1	0	R/W	
0	CH0	0	R/W	<ul style="list-style-type: none"> • When SCANE = 0 and SCANS = x <ul style="list-style-type: none"> 0000: AN0 0001: AN1 0010: AN2 0011: AN3 0100: AN4 0101: AN5 0110: AN6 0111: AN7 1xxx: Setting prohibited • When SCANE = 1 and SCANS = 0 <ul style="list-style-type: none"> 0000: AN0 0001: AN0 and AN1 0010: AN0 to AN2 0011: AN0 to AN3 0100: AN4 0101: AN4 and AN5 0110: AN4 to AN6 0111: AN4 to AN7 1xxx: Setting prohibited • When SCANE = 1 and SCANS = 1 <ul style="list-style-type: none"> 0000: AN0 0001: AN0 and AN1 0010: AN0 to AN2 0011: AN0 to AN3 0100: AN0 to AN4 0101: AN0 to AN5 0110: AN0 to AN6 0111: AN0 to AN7 1xxx: Setting prohibited

[Legend]

x: Don't care

Note: * Only 0 can be written to this bit, to clear the flag.

19.3.3 A/D Control/Status Register for Unit 1 (ADCSR_1)

ADCSR_1 controls A/D conversion operations.

Bit	7	6	5	4	3	2	1	0
Bit Name	ADF	ADIE	ADST	EXCKS	CH3	CH2	CH1	CH0
Initial Value	0	0	0	0	0	0	0	0
R/W	R/(W)*	R/W	R/W	R/W	R/W	R/W	R/W	R/W

Note: * Only 0 can be written to this bit, to clear the flag.

Bit	Bit Name	Initial Value	R/W	Description
7	ADF	0	R/(W)*	<p>A/D end flag</p> <p>A status flag that indicates the end of A/D conversion.</p> <p>[Setting conditions]</p> <ul style="list-style-type: none"> • Completion of A/D conversion in single mode • Completion of A/D conversion on all specified channels in scan mode <p>[Clearing conditions]</p> <ul style="list-style-type: none"> • Writing of 0 after reading ADF = 1 (When the CPU is used to clear this flag by writing 0 while the corresponding interrupt is enabled, be sure to read the flag after writing 0 to it.) • Reading from ADDR after activation of the DMAC or DTC by an ADI interrupt
6	ADIE	0	R/W	<p>A/D interrupt enable</p> <p>Setting this bit to 1 enables ADI interrupts by ADF.</p>
5	ADST	0	R/W	<p>A/D Start</p> <p>Clearing this bit to 0 stops A/D conversion, and the A/D converter enters wait state.</p> <p>Setting this bit to 1 starts A/D conversion. In single mode, this bit is cleared to 0 automatically when A/D conversion on the specified channel ends. In scan mode, A/D conversion continues sequentially on the specified channels until this bit is cleared to 0 by software, a reset, or hardware standby mode.</p> <p>Note: Do not write to ADST when activation is by an external trigger. For details, see section 19.7.3, Notes on A/D Activation by an External Trigger.</p>

Bit	Bit Name	Initial Value	R/W	Description
4	EXCKS	0	R/W	Clock extension select Specifies the A/D conversion time in combination with the CKS1 and CKS0 bits in ADCR. Be sure to set these three bits at one time. For details, see the description of the ADCR registers.
3	CH3	0	R/W	Channel select 3 to 0
2	CH2	0	R/W	Selects analog input together with bits SCANE and SCANS in ADCR.
1	CH1	0	R/W	
0	CH0	0	R/W	<ul style="list-style-type: none"> • When SCANE = 0 and SCANS = X <ul style="list-style-type: none"> 00XX: Setting prohibited 0100: AN4 0101: AN5 0110: AN6 0111: AN7 1XXX: Setting prohibited • When SCANE = 1 and SCANS = 0 <ul style="list-style-type: none"> 00XX: Setting prohibited 0100: AN4 0101: AN4 and AN5 0110: AN4 to AN6 0111: AN4 to AN7 1XXX: Setting prohibited • When SCANE = 1 and SCANS = 1 <ul style="list-style-type: none"> XXXX: Setting prohibited

[Legend]

x: Don't care

Note: * Only 0 can be written to this bit, to clear the flag.

19.3.4 A/D Control Register for Unit 0 (ADCR_0)

ADCR enables A/D conversion to be started by an external trigger input.

Bit	7	6	5	4	3	2	1	0
Bit Name	TRGS1	TRGS0	SCANE	SCANS	CKS1	CKS0	-	EXTRGS
Initial Value	0	0	0	0	0	0	0	0
R/W	R/W	R/W	R/W	R/W	R/W	R/W	R/W	R/W

Bit	Bit Name	Initial Value	R/W	Description
7	TRGS1	0	R/W	Timer trigger select 1 and 0, extended trigger select
6	TRGS0	0	R/W	These bits select enabling or disabling of the start of A/D conversion by a trigger signal.
0	EXTRGS	0	R/W	<p>000: Disables A/D conversion start by external trigger</p> <p>010: Enables A/D conversion start by external trigger from TPU (unit 0)</p> <p>100: Enables A/D conversion start by external trigger from TMR (units 0 and 1)</p> <p>110: Enables A/D conversion start by the $\overline{\text{ADTRG0}}$ pin*¹</p> <p>001: External trigger disabled</p> <p>011: Setting prohibited</p> <p>101: Setting prohibited</p> <p>111: Enables A/D conversion start by the $\overline{\text{ADTRG0}}$ pin*¹ (starts units simultaneously)</p> <p>Note: Do not write to ADST when activation is by an external trigger. For details, see section 19.7.3, Notes on A/D Activation by an External Trigger.</p>
5	SCANE	0	R/W	Scan mode
4	SCANS	0	R/W	<p>These bits select the A/D conversion operating mode.</p> <p>0x: Single mode</p> <p>10: Scan mode. A/D conversion is performed continuously for channels 1 to 4.</p> <p>11: Scan mode. A/D conversion is performed continuously for channels 1 to 8.</p>

Bit	Bit Name	Initial Value	R/W	Description
3	CKS1	0	R/W	Clock Select 1 and 0
2	CKS0	0	R/W	<p>These bits set the A/D conversion time. First select the A/D conversion time by setting bits CKS1 and CKS0 while ADST = 0 and then set the mode of A/D conversion.</p> <p>CKS1, and CKS0</p> <p>00: A/D conversion time = 530 states*² (max.)</p> <p>01: A/D conversion time = 266 states*² (max.)</p> <p>10: A/D conversion time = 134 states*² (max.)</p> <p>11: A/D conversion time = 68 states*² (max.)</p>
1	—	0	R/W	<p>Reserved</p> <p>This bit is always read as 0. The write value should always be 0.</p>

[Legend]

x: Don't care

- Notes: 1. To set A/D conversion to start by the $\overline{\text{ADTRG}}$ pin, the DDR bit and ICR bit for the corresponding pin should be set to 0 and 1, respectively. For details, see section 12, I/O Ports.
2. $P\phi$ criterion

19.3.5 A/D Control Register for Unit 1 (ADCR_1)

ADCR enables A/D conversion to be started by an external trigger input.

Bit	7	6	5	4	3	2	1	0
Bit Name	TRGS1	TRGS0	SCANE	SCANS	CKS1	CKS0	ADSTCLR	EXTRGS
Initial Value	0	0	0	0	0	0	0	0
R/W	R/W	R/W	R/W	R/W	R/W	R/W	R/W	R/W

Bit	Bit Name	Initial Value	R/W	Description
7	TRGS1	0	R/W	Timer Trigger Select 1 and 0, extended trigger select
6	TRGS0	0	R/W	These bits select enabling or disabling of the start of A/D conversion by a trigger signal.
0	EXTRGS	0	R/W	000: Disables A/D conversion start by external trigger 010: Setting prohibited 100: Setting prohibited 110: Enables A/D conversion start by the $\overline{\text{ADTRG1}}$ pin* ¹ 001: Setting prohibited 011: External trigger disabled 101: Enables A/D conversion start by external trigger from TMR (units 2 and 3) 111: Enables A/D conversion start by the $\overline{\text{ADTRG0}}$ pin* ¹ (starts units simultaneously)
Note: Do not write to ADST when activation is by an external trigger. For details, see section 19.7.3, Notes on A/D Activation by an External Trigger.				
5	SCANE	0	R/W	Scan Mode
4	SCANS	0	R/W	These bits select the A/D conversion operating mode. 0x: Single mode 10: Scan mode. A/D conversion is performed continuously for channels 1 to 4. 11: Setting prohibited

Bit	Bit Name	Initial Value	R/W	Description
3	CKS1	0	R/W	Clock Select 1 and 0
2	CKS0	0	R/W	<p>These bits set the A/D conversion time in combination with the EXCKS bit. First select the A/D conversion time by setting bits CKS1 and CKS0 while ADST = 0 and then set the mode of A/D conversion.</p> <p>EXCKS, CKS1, and CKS0</p> <p>000: A/D conversion time = 530 states*² (max.)</p> <p>001: A/D conversion time = 266 states*² (max.)</p> <p>010: A/D conversion time = 134 states*² (max.)</p> <p>011: A/D conversion time = 68 states*² (max.)</p> <p>100: A/D conversion time = 332 states*² (max.)</p> <p>101: A/D conversion time = 168 states*² (max.)</p> <p>110: A/D conversion time = 87 states*² (max.)</p> <p>111: A/D conversion time = 46 states*² (max.)</p>
1	ADSTCLR	0	R/W	<p>A/D Start Clear</p> <p>This bit enables or disables automatic clearing of the ADST bit in scan mode.</p> <p>0: The ADST bit is not automatically cleared to 0 in scan mode.</p> <p>1: Clears the ADST bit to 0 upon completion of the A/D conversion for all of the selected channels in scan mode.</p>

[Legend]

x: Don't care

- Notes:
1. To set A/D conversion to start by the $\overline{\text{ADTRG}}$ pin, the DDR bit and ICR bit for the corresponding pin should be set to 0 and 1, respectively. For details, see section 12, I/O Ports.
 2. $P\phi$ criterion

19.4 Operation

The A/D converter has two operating modes: single mode and scan mode. First select the clock for A/D conversion (ADCLK). When changing the operating mode or analog input channel, to prevent incorrect operation, first clear the ADST bit in ADCSR to 0. The ADST bit can be set to 1 at the same time as the operating mode or analog input channel is changed.

19.4.1 Single Mode

In single mode, A/D conversion is to be performed only once on the analog input of the specified single channel.

1. A/D conversion for the selected channel is started when the ADST bit in ADCSR is set to 1 by software, TPU*¹, TMR*², or an external trigger input.
2. When A/D conversion is completed, the A/D conversion result is transferred to the corresponding A/D data register of the channel.
3. When A/D conversion is completed, the ADF bit in ADCSR is set to 1. If the ADIE bit is set to 1 at this time, an ADI interrupt request is generated.
4. The ADST bit remains at 1 during A/D conversion, and is automatically cleared to 0 when A/D conversion ends. The A/D converter enters wait state. If the ADST bit is cleared to 0 during A/D conversion, A/D conversion stops and the A/D converter enters a wait state.

Notes: 1. Only possible in unit 0.

2. As conversion start trigger, units 0 and 1 of TMR, and units 2 and 3 of TMR are available in unit 0, and unit 1, respectively.

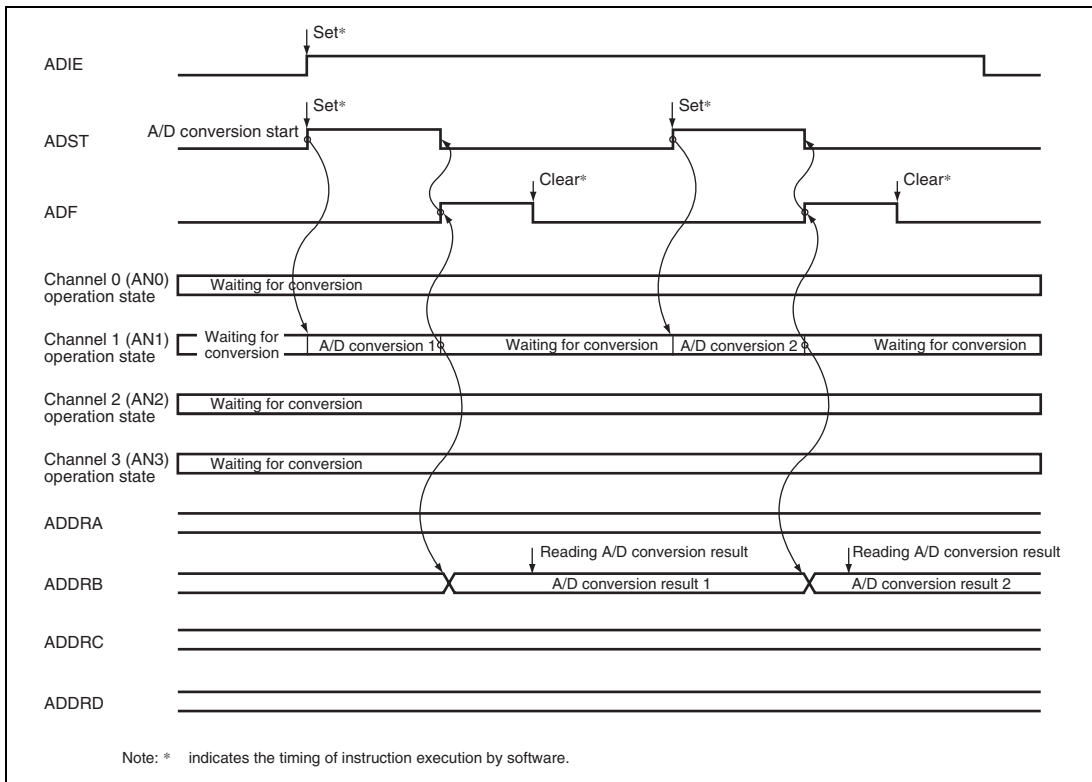

Figure 19.3 Example of A/D Converter Operation (Single Mode, Channel 1 Selected)

19.4.2 Scan Mode

In scan mode, A/D conversion is to be performed sequentially on the analog inputs of the specified channels up to four or eight*¹ channels. Two types of scan mode are provided, that is, continuous scan mode where A/D conversion*¹ is repeatedly performed and one-cycle scan mode where A/D conversion is performed for the specified channels for one cycle.

(1) Continuous Scan Mode

1. When the ADST bit in ADCSR is set to 1 by software, TPU*¹, TMR*², or an external trigger input, A/D conversion starts on the first channel in the specified channel group. Consecutive A/D conversion*¹ on a maximum of four channels (SCANE and SCANS = B'10) or on a maximum of eight channels (SCANE and SCANS = B'11) can be selected. When consecutive A/D conversion is performed on four channels, A/D conversion starts on AN0 when CH3 and CH2 of unit 0 = B'00, on AN4 when CH3 and CH2 of units 0 and 1 = B'01. When

consecutive A/D conversion is performed on eight channels*¹, A/D conversion starts on AN0 when CH3 = B'0.

- When A/D conversion for each channel is completed, the A/D conversion result is sequentially transferred to the corresponding ADDR of each channel.
- When A/D conversion of all selected channels is completed, the ADF bit in ADCSR is set to 1. If the ADIE bit is set to 1 at this time, an ADI interrupt request is generated. A/D conversion of the first channel in the group starts again.
- The ADST bit is not cleared automatically, and steps 2 to 3 are repeated as long as the ADST bit remains set to 1. When the ADST bit is cleared to 0, A/D conversion stops and the A/D converter enters wait state. If the ADST bit is later set to 1, A/D conversion starts again from the first channel in the group.

Notes: 1. Consecutive A/D conversion on eight channels is only possible in unit 0.

- As conversion start trigger, units 0 and 1 of TMR, and units 2 and 3 of TMR are available in unit 0, and unit 1, respectively.

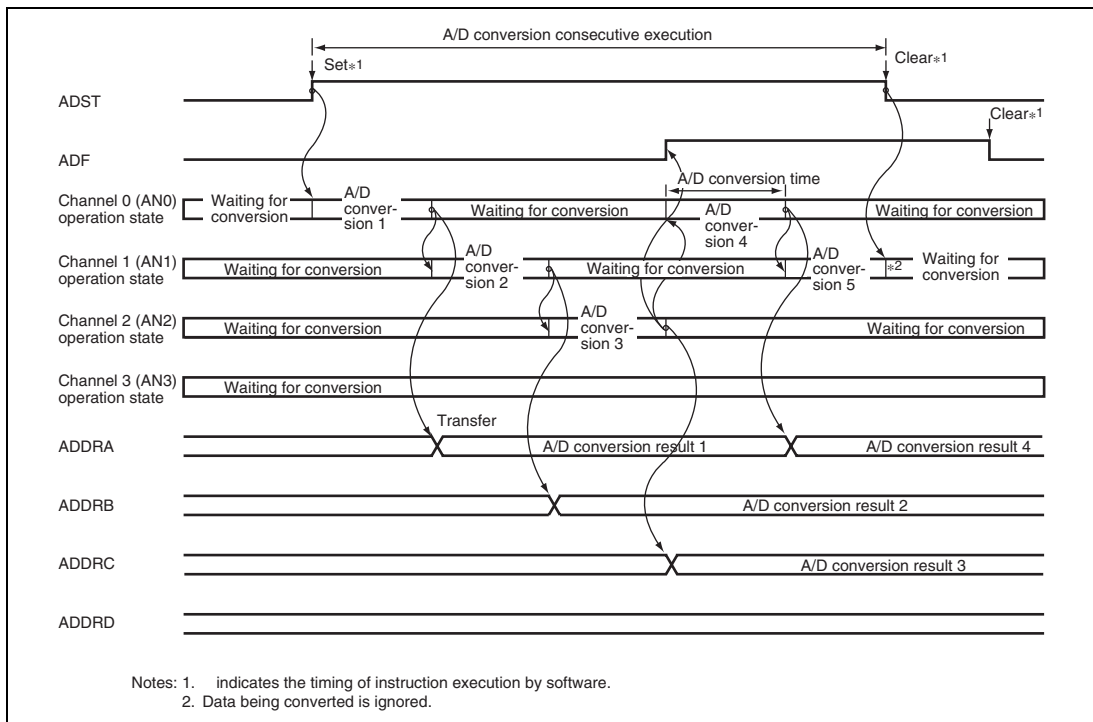
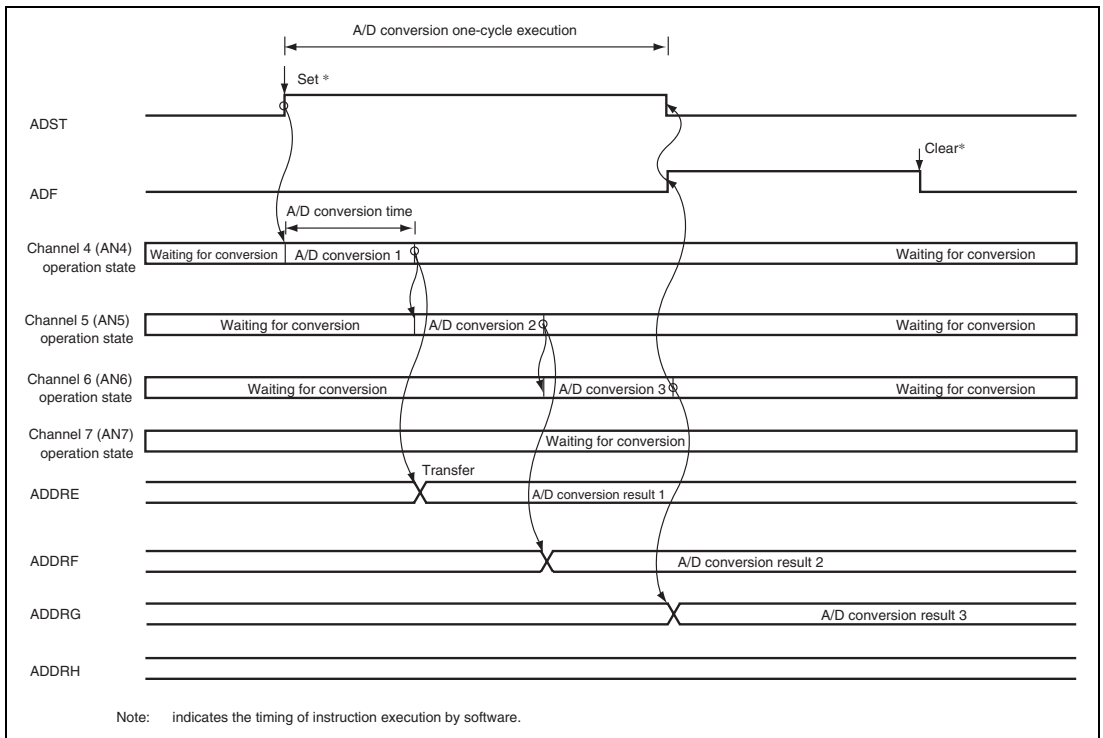

Figure 19.4 Example of A/D Conversion
(Continuous Scan Mode, Three Channels (AN0 to AN2) Selected)

(2) One-Cycle Scan Mode (only enabled in unit 1)

1. Set the ADSTCLR bit in ADCR to 1.
2. When the ADST bit in ADCSR is set to 1 by software, TMR (units 2 and 3), or an external trigger input, A/D conversion starts on the first channel in the specified channel group. Consecutive A/D conversion on a maximum of four channels (SCANE and SCANS = B'10) can be selected. For unit 1, A/D conversion starts on AN4 when CH3 and CH2 = B'01.
3. When A/D conversion for each channel is completed, the A/D conversion result is sequentially transferred to the corresponding ADDR of each channel.
4. When A/D conversion of all selected channels is completed, the ADF bit in ADCSR is set to 1. If the ADIE bit is set to 1 at this time, an ADI interrupt request is generated.
5. The ADST bit is automatically cleared when A/D conversion is completed for all of the channels that have been selected. A/D conversion stops and the A/D converter enters a wait state.



**Figure 19.5 Example of A/D Conversion
(One-Cycle Scan Mode, Three Channels (AN4 to AN6) Selected)**

19.4.3 Input Sampling and A/D Conversion Time

The A/D converter has a built-in sample-and-hold circuit. The A/D converter samples the analog input when the A/D conversion start delay time (t_D) passes after the ADST bit in ADCSR is set to 1, then starts A/D conversion. Figure 19.6 shows the A/D conversion timing. Tables 19.3 and 19.4 show the A/D conversion time.

As shown in figure 19.6, the A/D conversion time (t_{CONV}) includes the A/D conversion start delay time (t_D) and the input sampling time (t_{SPL}). The length of t_D varies depending on the timing of the write access to ADCSR. The total conversion time therefore varies within the ranges indicated in tables 19.3 and 19.4.

In scan mode, the values given in tables 19.3 and 19.4 apply to the first conversion time. The values given in table 19.5 apply to the second and subsequent conversions. In either case, bits CKS1 and CKS0 in ADCR should be set so that the conversion time is within the ranges indicated by the A/D conversion characteristics.

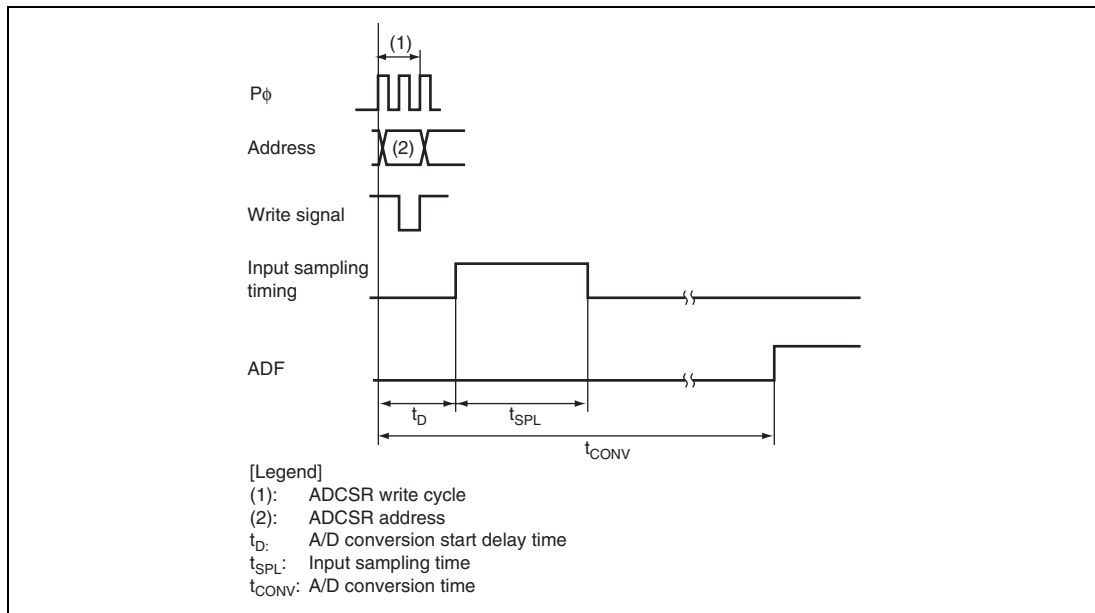

Figure 19.6 A/D Conversion Timing

Table 19.3 A/D Conversion Characteristics (EXCK1 = 0)

Item	Symbol	CKS1 = 0						CKS1 = 1					
		CKS = 0			CKS = 1			CKS = 0			CKS = 1		
		Min.	Typ.	Max.	Min.	Typ.	Max.	Min.	Typ.	Max.	Min.	Typ.	Max.
A/D conversion start delay time	t_D	4	—	14	4	—	10	4	—	8	3	—	7
Input sampling time	t_{SPL}	—	312	—	—	156	—	—	78	—	—	39	—
A/D conversion time	t_{CONV}	518	—	528	262	—	268	134	—	138	69	—	73

Note: Values in the table are the number of states.

Table 19.4 A/D Conversion Characteristics (EXCK1 = 1: Unit 1)

Item	Symbol	CKS1 = 0						CKS1 = 1					
		CKS = 0			CKS = 1			CKS = 0			CKS = 1		
		Min.	Typ.	Max.	Min.	Typ.	Max.	Min.	Typ.	Max.	Min.	Typ.	Max.
A/D conversion start delay time	t_D	4	—	14	4	—	10	4	—	8	3	—	7
Input sampling time	t_{SPL}	—	120	—	—	60	—	—	30	—	—	15	—
A/D conversion time	t_{CONV}	326	—	336	166	—	172	86	—	90	45	—	49

Note: Values in the table are the number of states.

Table 19.5 A/D Conversion Time (Scan Mode) (Unit 0)

CKS1	CKS0	Conversion Time (Number of States)
0	0	512 (fixed)
	1	256 (fixed)
1	0	128 (fixed)
	1	64 (fixed)

Table 19.6 A/D Conversion Time (Scan Mode) (Unit 1)

EXCKS	CKS1	CKS0	Conversion Time (Number of States)
0	0	0	512 (fixed)
		1	256 (fixed)
	1	0	128 (fixed)
		1	64 (fixed)
1	0	0	320 (fixed)
		1	160 (fixed)
	1	0	80 (fixed)
		1	40 (fixed)

19.4.4 External Trigger Input Timing

A/D conversion can be externally triggered. For unit 0, an external trigger is input from the $\overline{\text{ADTRG0}}$ pin when the TRGS1, TRGS0, and EXTRGS bits are set to B'110 in ADCR_0. For unit 1, an external trigger is input from the $\overline{\text{ADTRG1}}$ pin when the TRGS1, TRGS0, and EXTRGS bits are set to B'110 in ADCR_1. A/D conversion starts when the ADST bit in ADCSR is set to 1 on the falling edge of the $\overline{\text{ADTRG}}$ pin. Other operations, in both single and scan modes, are the same as when the ADST bit has been set to 1 by software. Figure 19.7 shows the timing.

Also, A/D conversion for multiple units can be externally triggered (multiple units can start simultaneously). For units 0 and 1, an external trigger is input from the $\overline{\text{ADTRG0}}$ pin when the TRGS1, TRGS0, and EXTRGS bits are set to B'111 in ADCR_0 and ADCR_1. A/D conversion starts when the ADST bit in ADCSR is set to 1 on the falling edge of the $\overline{\text{ADTRG}}$ pin. The timing is different from the one when multiple units do not start simultaneously. Figure 19.8 shows the timing.

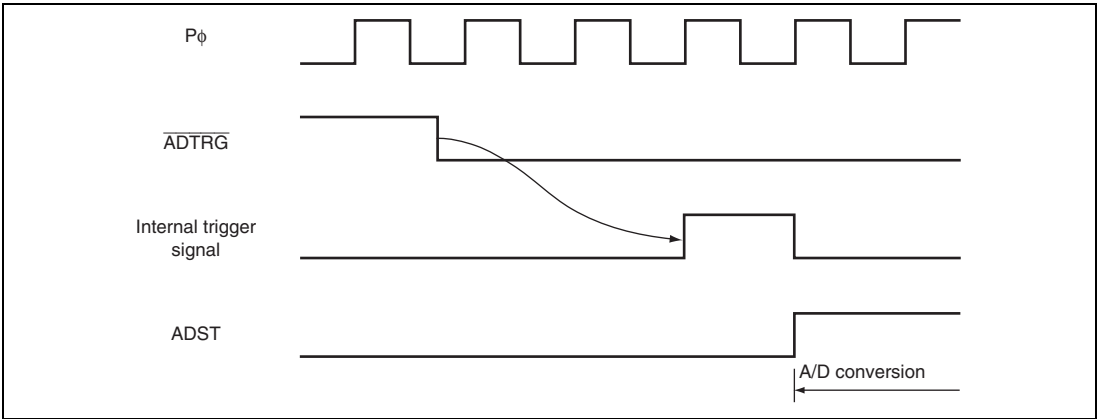

Figure 19.7 External Trigger Input Timing (TRGS1, TRGS0, and EXTRGS ≠ B'111)

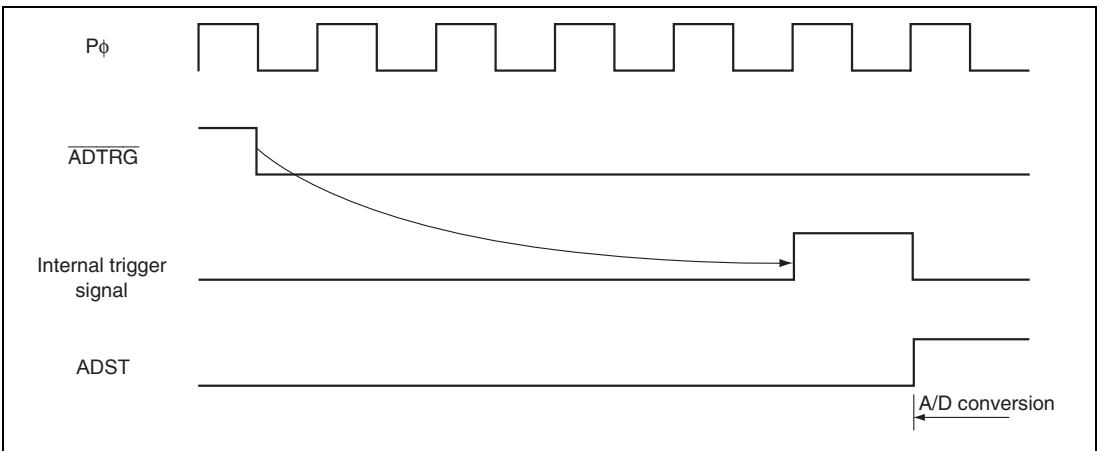

Figure 19.8 External Trigger Input Timing when Multiple Units Start Simultaneously (TRGS1, TRGS0, and EXTRGS = B'111)

19.5 Interrupt Source

The A/D converter generates an A/D conversion end interrupt (ADI) at the end of A/D conversion. Setting the ADIE bit to 1 when the ADF bit in ADCSR is set to 1 after A/D conversion is completed enables ADI interrupt requests. The data transfer controller (DTC)* and DMA controller (DMAC) can be activated by an ADI interrupt. Having the converted data read by the DTC* or DMAC in response to an ADI interrupt enables continuous conversion to be achieved without imposing a load on software.

Note: * Only possible in unit 0.

Table 19.7 A/D Converter Interrupt Source

Name	Interrupt Source	Interrupt Flag	DTC Activation	DMAC Activation
ADI0	A/D conversion end	ADF	Possible*	Possible

Note: * Only possible in unit 0.

19.6 A/D Conversion Accuracy Definitions

This LSI's A/D conversion accuracy definitions are given below.

- **Resolution**
The number of A/D converter digital output codes.
- **Quantization error**
The deviation inherent in the A/D converter, given by 1/2 LSB (see figure 19.9).
- **Offset error**
The deviation of the analog input voltage value from the ideal A/D conversion characteristic when the digital output changes from the minimum voltage value B'000000000 (H'000) to B'000000001 (H'001) (see figure 19.10).
- **Full-scale error**
The deviation of the analog input voltage value from the ideal A/D conversion characteristic when the digital output changes from B'111111110 (H'3FE) to B'111111111 (H'3FF) (see figure 19.10).
- **Nonlinearity error**
The error with respect to the ideal A/D conversion characteristic between the zero voltage and the full-scale voltage. Does not include the offset error, full-scale error, or quantization error (see figure 19.10).
- **Absolute accuracy**
The deviation between the digital value and the analog input value. Includes the offset error, full-scale error, quantization error, and nonlinearity error.

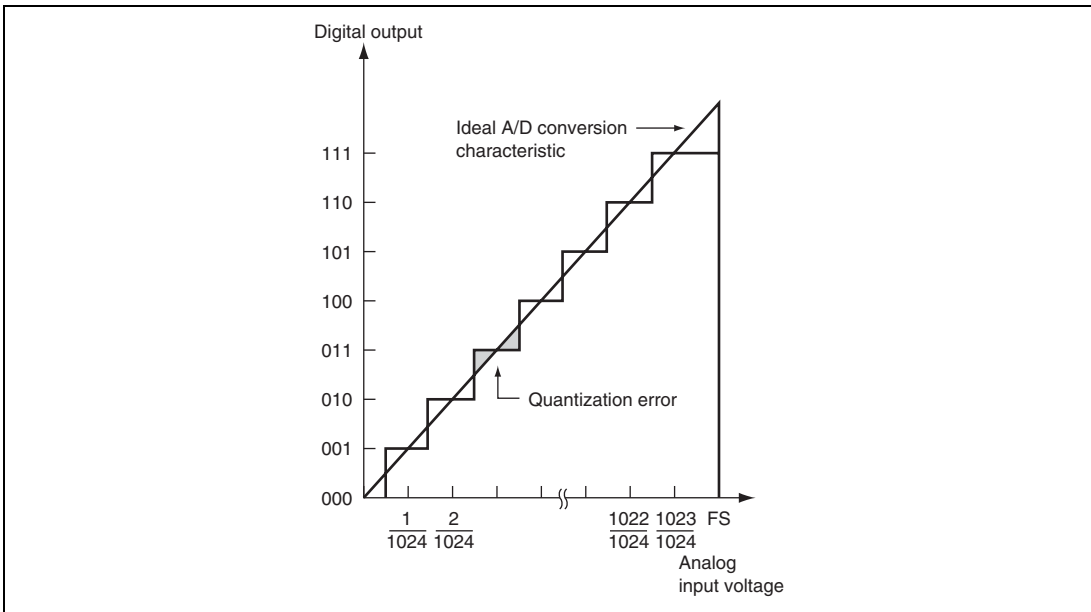

Figure 19.9 A/D Conversion Accuracy Definitions

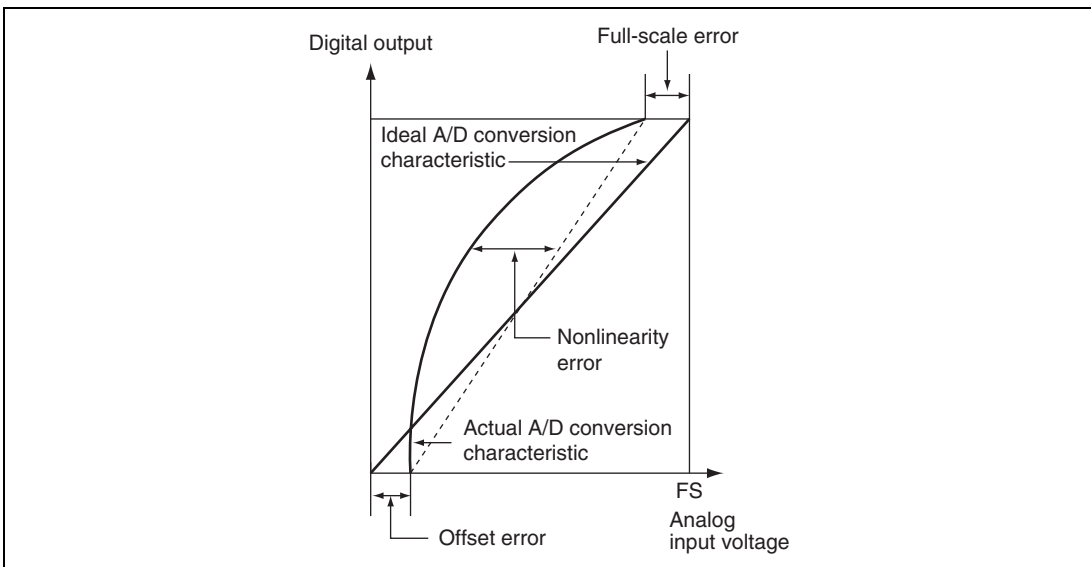

Figure 19.10 A/D Conversion Accuracy Definitions

19.7 Usage Notes

19.7.1 Module Stop Function Setting

Operation of the A/D converter can be disabled or enabled using the module stop control register. The initial setting is for operation of the A/D converter to be halted. Register access is enabled by clearing the module stop state. Set the CKS1 and CKS2 bits to 1 and clear the ADST, TRGS1, TRGS0, and EXTRGS bits all to 0 to disable A/D conversion when entering module stop state after operation of the A/D converter. After that, set the module stop control register after executing a dummy read by one word. For details, see section 25, Power-Down Modes.

19.7.2 A/D Input Hold Function in Software Standby Mode

When this LSI enters software standby mode with A/D conversion enabled, the analog inputs are retained, and the analog power supply current is equal to as during A/D conversion. If the analog power supply current needs to be reduced in software standby mode, set the CKS1 and CKS2 bits to 1 and clear the ADST, TRGS1, TRGS0, and EXTRGS bits all to 0 to disable A/D conversion. After that, enter software standby mode after executing a dummy read by one word.

19.7.3 Notes on A/D Activation by an External Trigger

If any of actions (1 to 3 below) is performed while activation by an external trigger* is in use, stopping A/D conversion may be impossible.

Note: * External trigger refers to input on the ADTRG pin or the conversion trigger from a peripheral module (TMR or TPU).

1. When the setting for activation by an external trigger is in use, writing to change the value of the ADST bit in ADCSR from 0 to 1.
2. Changing the setting from activation by an external trigger to prohibition of external triggers.
3. Changing the scan mode (SCANE and ADSTLCR bits; from continuous scan mode to single mode or single-cycle scan mode) while the setting is for activation by an external trigger.

If any of the above points apply, make the corresponding settings listed below.

1. If point 1 is applicable

Do not perform writing to change the value of the ADST bit in ADCSR from 0 to 1 when the setting for activation by an external trigger is in use.

2. If a point 2 or 3 is applicable

Only execute switching from activation by an external trigger to prohibition of external triggers or changing of the scan mode (ADSTLCR and SCANE bits) when the setting for activation by an external trigger is in use after external trigger input has been disabled.

External trigger input can be disabled by writing specific values to bits TRGS1, TRGS0, and EXTRGS.

For details on the procedure in cases where point 2 or 3 is applicable, see figure 19.11.

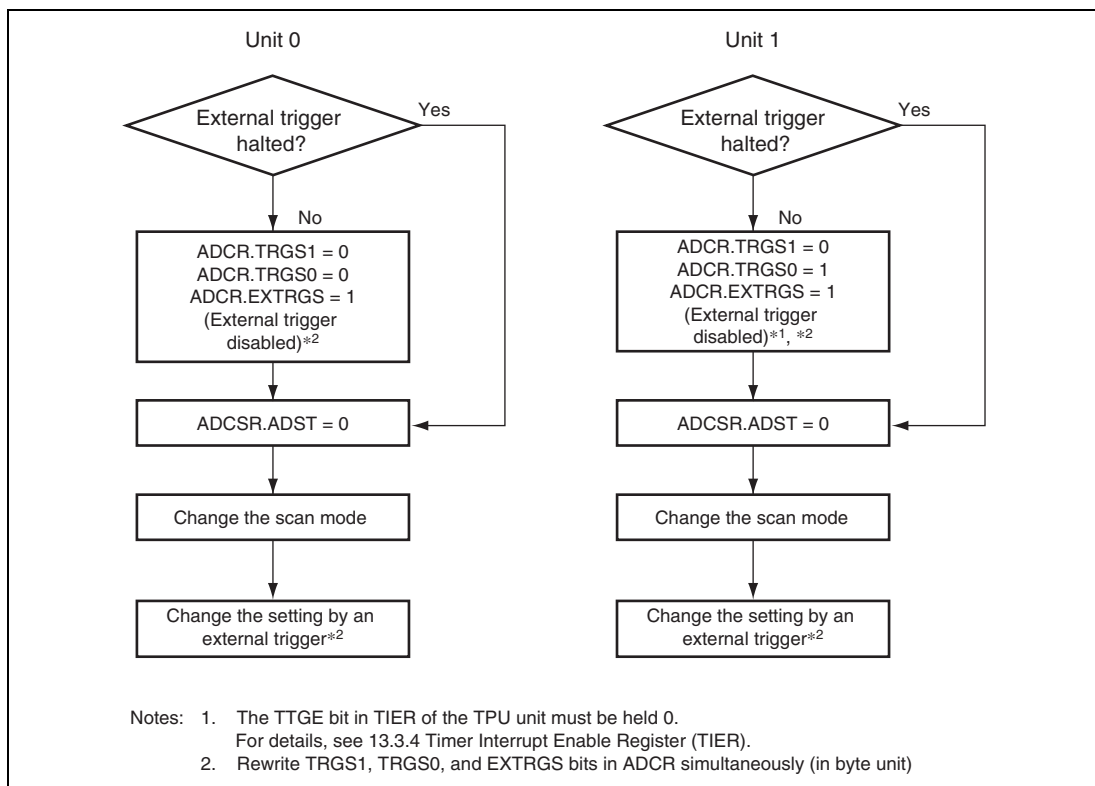

Figure 19.11 Procedure for Changing the Mode When the Setting for Activation by an External Trigger is in Use

19.7.4 Permissible Signal Source Impedance

This LSI's analog input is designed so that the conversion accuracy is guaranteed for an input signal for which the signal source impedance is $5\text{ k}\Omega$ or less. This specification is provided to enable the A/D converter's sample-and-hold circuit input capacitance to be charged within the sampling time; if the sensor output impedance exceeds $5\text{ k}\Omega$, charging may be insufficient and it may not be possible to guarantee the A/D conversion accuracy. However, if a large capacitance is provided externally for conversion in single mode, the input load will essentially comprise only the internal input resistance of $10\text{ k}\Omega$, and the signal source impedance is ignored. However, since a low-pass filter effect is obtained in this case, it may not be possible to follow an analog signal with a large differential coefficient (e.g., $5\text{ mV}/\mu\text{s}$ or greater) (see figure 19.12). When converting a high-speed analog signal or conversion in scan mode, a low-impedance buffer should be inserted.

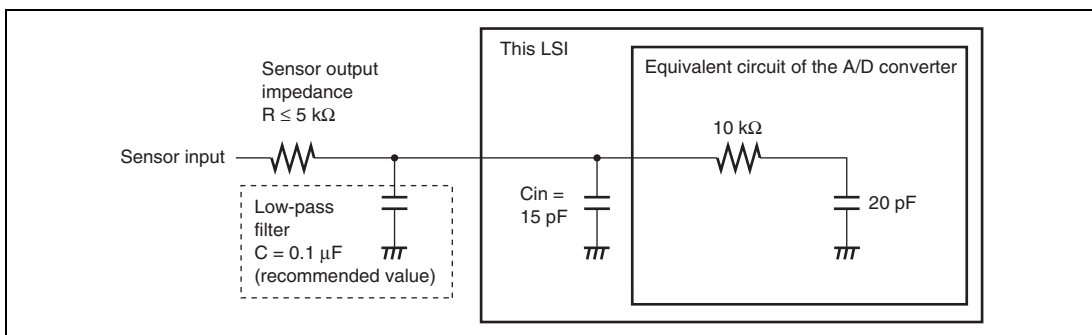

Figure 19.12 Example of Analog Input Circuit

19.7.5 Influences on Absolute Accuracy

Adding capacitance results in coupling with GND, and therefore noise in GND may adversely affect absolute accuracy. Be sure to make the connection to an electrically stable GND such as AVss.

Care is also required to insure that filter circuits do not communicate with digital signals on the mounting board, acting as antennas.

19.7.6 Setting Range of Analog Power Supply and Other Pins

If the conditions shown below are not met, the reliability of the LSI may be adversely affected.

- Analog input voltage range
The voltage applied to analog input pin ANn during A/D conversion should be in the range $AV_{SS} \leq V_{AN} \leq V_{ref}$.
- Relation between AVcc, AVss and Vcc, Vss
As the relationship between AVcc, AVss and Vcc, Vss, set $AV_{cc} = V_{cc} \pm 0.3 \text{ V}$ and $AV_{ss} = V_{ss}$. If the A/D converter is not used, set $AV_{cc} = V_{cc}$ and $AV_{ss} = V_{ss}$.
- Vref setting range
The reference voltage at the Vref pin should be set in the range $V_{ref} \leq AV_{cc}$.

19.7.7 Notes on Board Design

In board design, digital circuitry and analog circuitry should be as mutually isolated as possible, and layout in which digital circuit signal lines and analog circuit signal lines cross or are in close proximity should be avoided as far as possible. Failure to do so may result in incorrect operation of the analog circuitry due to inductance, adversely affecting A/D conversion values.

Digital circuitry must be isolated from the analog input pins (AN0 to AN7), analog reference power supply (Vref), and analog power supply (AVcc) by the analog ground (AVss). Also, the analog ground (AVss) should be connected at one point to a stable ground (Vss) on the board.

19.7.8 Notes on Noise Countermeasures

A protection circuit connected to prevent damage due to an abnormal voltage such as an excessive surge at the analog input pins (AN0 to AN7) should be connected between AVcc and AVss as shown in figure 19.9. Also, the bypass capacitors connected to AVcc and the filter capacitor connected to the AN0 to AN7 pins must be connected to AVss.

If a filter capacitor is connected, the input currents at the AN0 to AN7 pins are averaged, and so an error may arise. Also, when A/D conversion is performed frequently, as in scan mode, if the current charged and discharged by the capacitance of the sample-and-hold circuit in the A/D converter exceeds the current input via the input impedance (R_{in}), an error will arise in the analog input pin voltage. Careful consideration is therefore required when deciding the circuit constants.

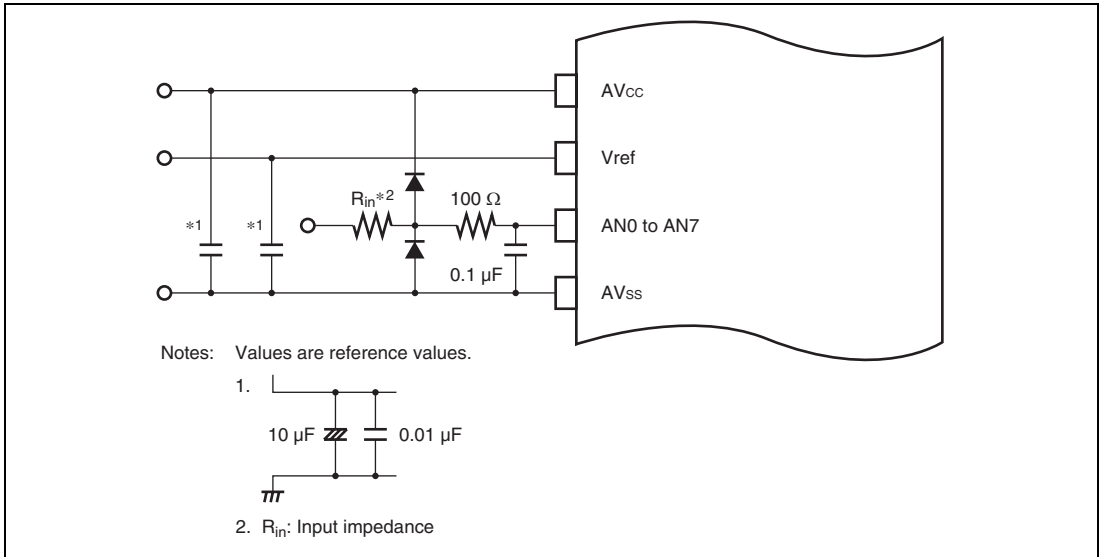

Figure 19.13 Example of Analog Input Protection Circuit

Table 19.8 Analog Pin Specifications

Item	Min.	Max.	Unit
Analog input capacitance	—	20	pF
Permissible signal source impedance	—	5	kΩ

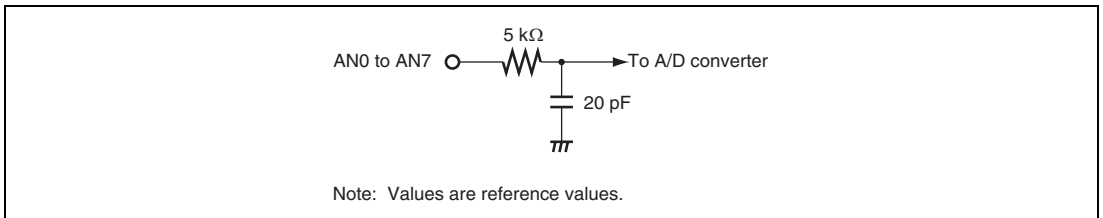

Figure 19.14 Analog Input Pin Equivalent Circuit

Section 20 D/A Converter

20.1 Features

- 8-bit resolution
- Two output channels
- Maximum conversion time of 10 μ s (with 20 pF load)
- Output voltage of 0 V to V_{ref}
- D/A output hold function in software standby mode
- Module stop state specifiable

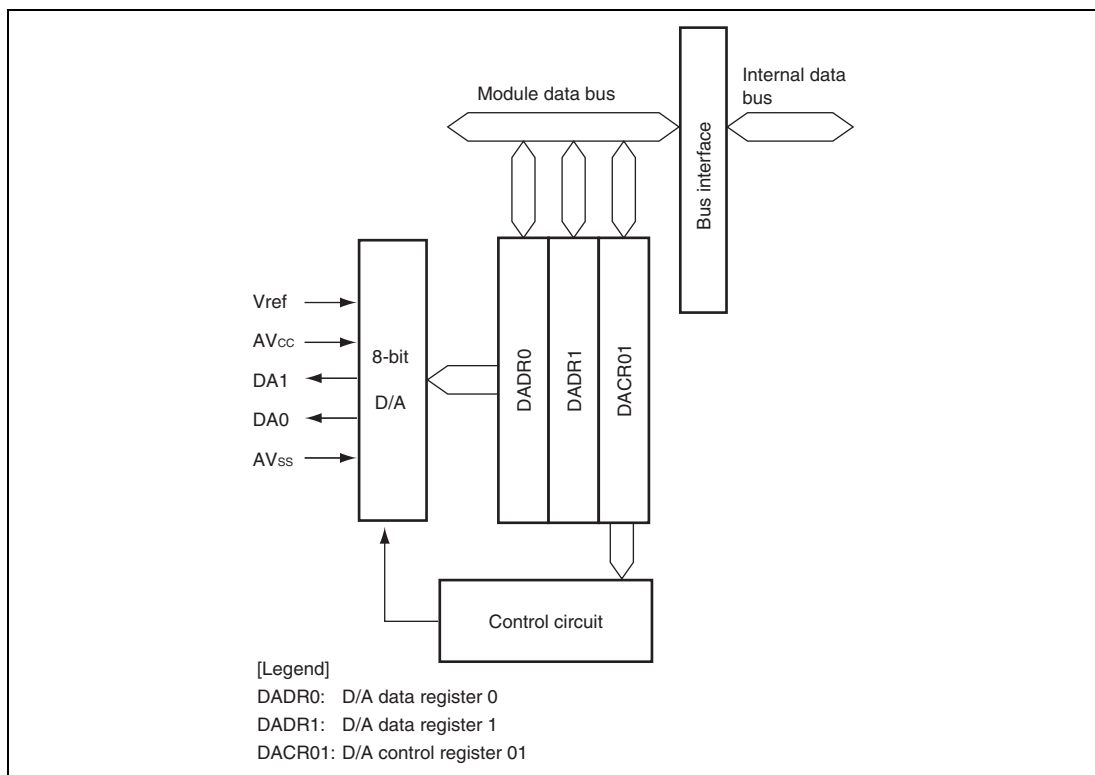

Figure 20.1 Block Diagram of D/A Converter

20.2 Input/Output Pins

Table 20.1 shows the pin configuration of the D/A converter.

Table 20.1 Pin Configuration

Pin Name	Symbol	I/O	Function
Analog power supply pin	AV _{cc}	Input	Analog block power supply
Analog ground pin	AV _{ss}	Input	Analog block ground
Reference voltage pin	V _{ref}	Input	D/A conversion reference voltage
Analog output pin 0	DA0	Output	Channel 0 analog output
Analog output pin 1	DA1	Output	Channel 1 analog output

20.3 Register Descriptions

The D/A converter has the following registers.

- D/A data register 0 (DADR0)
- D/A data register 1 (DADR1)
- D/A control register 01 (DACR01)

20.3.1 D/A Data Registers 0 and 1 (DADR0 and DADR1)

DADR0 and DADR1 are 8-bit readable/writable registers that store data to which D/A conversion is to be performed. Whenever an analog output is enabled, the values in DADR are converted and output to the analog output pins.

Bit	7	6	5	4	3	2	1	0
Bit Name								
Initial Value	0	0	0	0	0	0	0	0
R/W	R/W	R/W	R/W	R/W	R/W	R/W	R/W	R/W

20.3.2 D/A Control Register 01 (DACR01)

DACR01 controls the operation of the D/A converter.

Bit	7	6	5	4	3	2	1	0
Bit Name	DAOE1	DAOE0	DAE	—	—	—	—	—
Initial Value	0	0	0	1	1	1	1	1
R/W	R/W	R/W	R/W	R	R	R	R	R

Bit	Bit Name	Initial Value	R/W	Description
7	DAOE1	0	R/W	D/A Output Enable 1 Controls D/A conversion and analog output. 0: Analog output of channel 1 (DA1) is disabled 1: D/A conversion of channel 1 is enabled. Analog output of channel 1 (DA1) is enabled.
6	DAOE0	0	R/W	D/A Output Enable 0 Controls D/A conversion and analog output. 0: Analog output of channel 0 (DA0) is disabled 1: D/A conversion of channel 0 is enabled. Analog output of channel 0 (DA0) is enabled.
5	DAE	0	R/W	D/A Enable Used together with the DAOE0 and DAOE1 bits to control D/A conversion. When this bit is cleared to 0, D/A conversion is controlled independently for channels 0 and 1. When this bit is set to 1, D/A conversion for channels 0 and 1 is controlled together. Output of conversion results is always controlled by the DAOE0 and DAOE1 bits. For details, see Table 20.2, Control of D/A Conversion.
4 to 0	—	All 1	R	Reserved These are read-only bits and cannot be modified.

Table 20.2 Control of D/A Conversion

Bit 5 DAE	Bit 7 DAOE1	Bit 6 DAOE0	Description
0	0	0	D/A conversion is disabled.
		1	D/A conversion of channel 0 is enabled and D/A conversion of channel 1 is disabled. Analog output of channel 0 (DA0) is enabled and analog output of channel 1 (DA1) is disabled.
	1	0	D/A conversion of channel 0 is disabled and D/A conversion of channel 1 is enabled. Analog output of channel 0 (DA0) is disabled and analog output of channel 1 (DA1) is enabled.
		1	D/A conversion of channels 0 and 1 is enabled. Analog output of channels 0 and 1 (DA0 and DA1) is enabled.
		0	D/A conversion of channels 0 and 1 is enabled. Analog output of channels 0 and 1 (DA0 and DA1) is disabled.
	1	0	1
0			D/A conversion of channels 0 and 1 is enabled. Analog output of channel 0 (DA0) is disabled and analog output of channel 1 (DA1) is enabled.
1		0	D/A conversion of channels 0 and 1 is enabled. Analog output of channels 0 and 1 (DA0 and DA1) is enabled.
		1	D/A conversion of channels 0 and 1 is enabled. Analog output of channels 0 and 1 (DA0 and DA1) is disabled.

20.4 Operation

The D/A converter includes D/A conversion circuits for two channels, each of which can operate independently. When the DAOE bit in DACR01 is set to 1, D/A conversion is enabled and the conversion result is output.

An operation example of D/A conversion on channel 0 is shown below. Figure 20.2 shows the timing of this operation.

1. Write the conversion data to DADR0.
2. Set the DAOE0 bit in DACR01 to 1 to start D/A conversion. The conversion result is output from the analog output pin DA0 after the conversion time t_{DCONV} has elapsed. The conversion result continues to be output until DADR0 is written to again or the DAOE0 bit is cleared to 0. The output value is expressed by the following formula:

$$\text{Contents of DADR}/256 \times V_{\text{ref}}$$

3. If DADR0 is written to again, the conversion is immediately started. The conversion result is output after the conversion time t_{DCONV} has elapsed.
4. If the DAOE0 bit is cleared to 0, analog output is disabled.

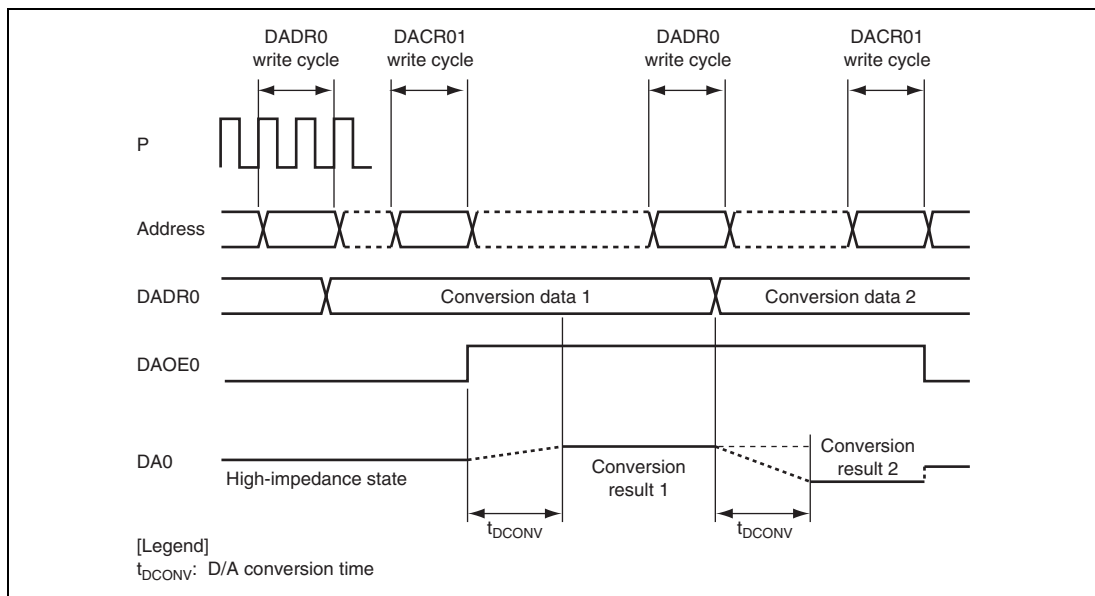

Figure 20.2 Example of D/A Converter Operation

20.5 Usage Notes

20.5.1 Module Stop State Setting

Operation of the D/A converter can be disabled or enabled using the module stop control register. The initial setting is for operation of the D/A converter to be halted. Register access is enabled by clearing the module stop state. For details, refer to section 25, Power-Down Modes.

20.5.2 D/A Output Hold Function in Software Standby Mode

When this LSI make a transition to software standby mode with D/A conversion enabled, the D/A outputs are retained, and the analog power supply current is equal to as during D/A conversion. If the analog power supply current needs to be reduced in software standby mode, clear the DAOE0, DAOE1, and DAE bits all to 0 to disable D/A conversion.

20.5.3 Notes on Deep Software Standby Mode

When this LSI make a transition to deep software standby mode, the D/A outputs high impedance state.

Section 21 RAM

This LSI has a high-speed static RAM. The RAM is connected to the CPU by a 32-bit data bus, enabling one-state access by the CPU to all byte data, word data, and longword data.

The RAM can be enabled or disabled by means of the RAME bit in the system control register (SYSCR). For details on SYSCR, refer to section 3.2.2, System Control Register (SYSCR).

The RAM size is 56 Kbytes in the H8SX/1638 and H8SX/1638L, 40 Kbytes in the H8SX/1634 and H8SX/1634L, and 24 Kbytes in the H8SX/1632 and H8SX/1632L.

Product Classification		RAM Size	RAM Addresses
Flash memory version	H8SX/1632	24 Kbytes	H'FF6000 to H'FFBFFF
	H8SX/1632L		
	H8SX/1634	40 Kbytes	H'FF2000 to H'FFBFFF
	H8SX/1634L		
	H8SX/1638	56 Kbytes	H'FEE000 to H'FFBFFF
	H8SX/1638L		

Section 22 Flash Memory

The flash memory has the following features. Figure 22.1 is a block diagram of the flash memory.

22.1 Features

- ROM size

Product Classification		ROM Size	ROM Address
H8SX/1632	R5F61632	256 Kbytes	H'000000 to H'03FFFF (modes 1, 2, 3, 6, and 7)
	R5F61632L		
H8SX/1634	R5F61634	512 Mbyte	H'000000 to H'07FFFF (modes 1, 2, 3, 6, and 7)
	R5F61634L		
H8SX/1638	R5F61638	1 Mbyte	H'000000 to H'0FFFFFFF (modes 1, 2, 3, 6, and 7)
	R5F61638L		

- Two memory MATs

The start addresses of two memory spaces (memory MATs) are allocated to the same address. The mode setting in the initiation determines which memory MAT is initiated first. The memory MATs can be switched by using the bank-switching method after initiation.

— User MAT initiated at a reset in user mode: 256 Kbytes/512 Kbytes/1 Mbyte

— User boot MAT is initiated at a reset in user boot mode: 16 Kbytes

- Programming/erasing interface by the download of on-chip program

This LSI has a programming/erasing program. After downloading this program to the on-chip RAM, programming/erasure can be performed by setting the parameters.

- Programming/erasing time

Programming time: 1 ms (typ.) for 128-byte simultaneous programming

Erasing time: 600 ms (typ.) per 1 block (64 Kbytes)

- Number of programming

The number of programming can be up to 100 times at the minimum. (1 to 100 times are guaranteed.)

- Three on-board programming modes

Boot mode: Using the on-chip SCI_4, the user MAT and user boot MAT can be programmed/erased. In boot mode, the bit rate between the host and this LSI can be adjusted automatically.

User program mode: Using a desired interface, the user MAT can be programmed/erased.

User boot mode: Using a desired interface, the user boot program can be made and the user MAT can be programmed/erased.

- Off-board programming mode

Programmer mode: Using a PROM programmer, the user MAT and user boot MAT can be programmed/erased.

- Programming/erasing protection

Protection against programming/erasure of the flash memory can be set by hardware protection, software protection, or error protection.

- Flash memory emulation function using the on-chip RAM

Realtime emulation of the flash memory programming can be performed by overlaying parts of the flash memory (user MAT) area and the on-chip RAM.

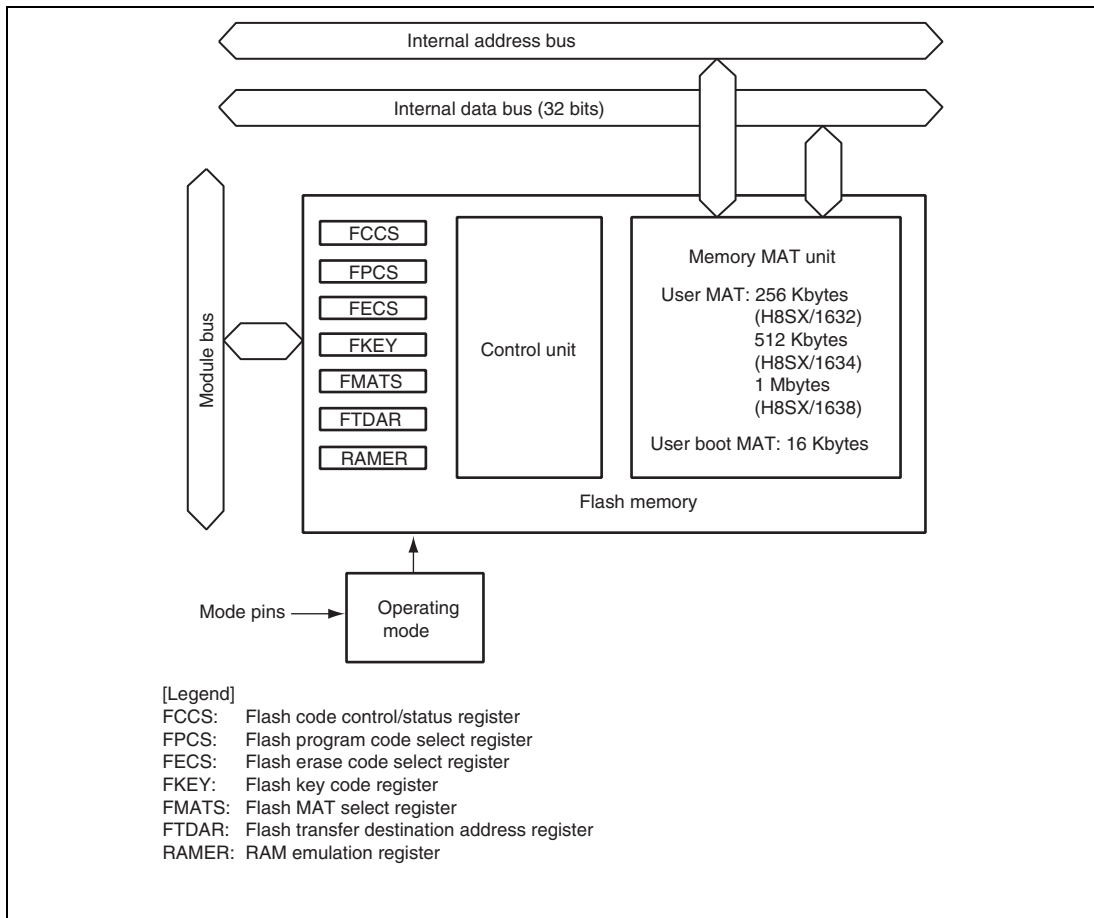

Figure 22.1 Block Diagram of Flash Memory

22.2 Mode Transition Diagram

When the mode pins are set in the reset state and reset start is performed, this LSI enters each operating mode as shown in figure 22.2. Although the flash memory can be read in user mode, it cannot be programmed or erased. The flash memory can be programmed or erased in boot mode, user program mode, user boot mode, and programmer mode. The differences between boot mode, user program mode, user boot mode, and programmer mode are shown in table 22.1.

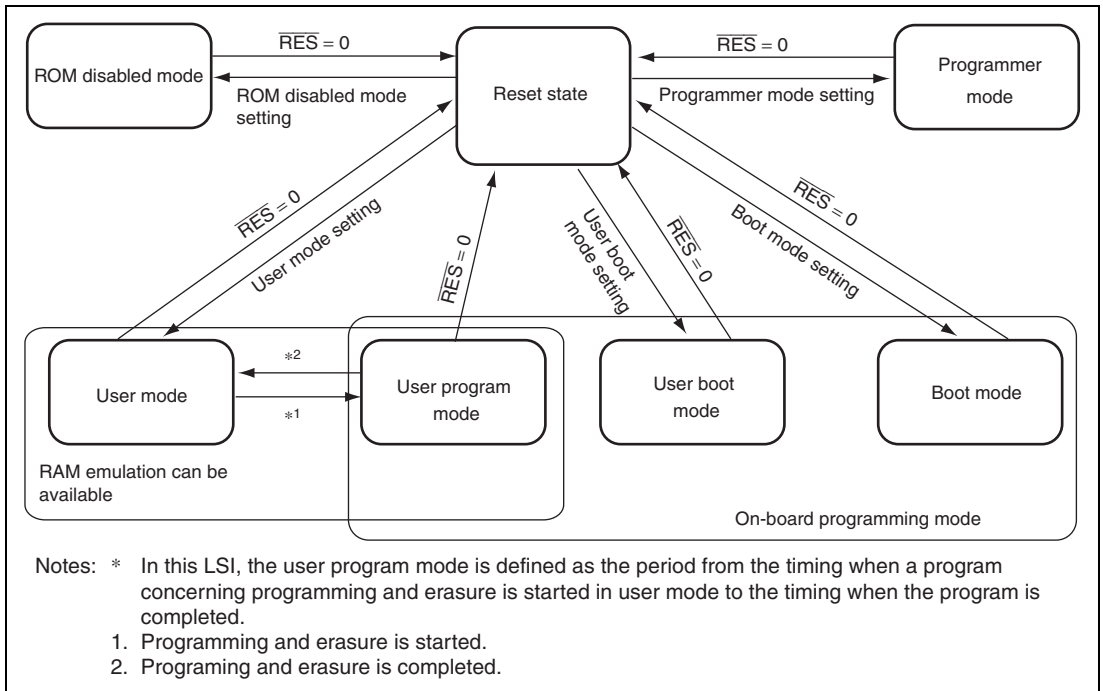

Figure 22.2 Mode Transition of Flash Memory

Table 22.1 Differences between Boot Mode, User Program Mode, User Boot Mode, and Programmer Mode

Item	Boot Mode	User Program Mode	User Boot Mode	Programmer Mode
Programming/erasing environment	On-board programming	On-board programming	On-board programming	Off-board programming
• Programming/erasing enable MAT	• User MAT • User boot MAT	• User MAT	• User MAT	• User MAT • User boot MAT
Programming/erasing control	Command	Programming/erasing interface	Programming/erasing interface	Command
All erasure	O (Automatic)	O	O	O (Automatic)
Block division erasure	O* ¹	O	O	×
Program data transfer	From host via SCI	From desired device via RAM	From desired device via RAM	Via programmer
RAM emulation	×	O	O	×
Reset initiation MAT	Embedded program storage area	User MAT	User boot MAT* ²	—
Transition to user mode	Changing mode and reset	Completing Programming/erasure* ³	Changing mode and reset	—

- Notes:
1. All-erasure is performed. After that, the specified block can be erased.
 2. First, the reset vector is fetched from the embedded program storage area. After the flash memory related registers are checked, the reset vector is fetched from the user boot MAT.
 3. In this LSI, the user programming mode is defined as the period from the timing when a program concerning programming and erasure is started to the timing when the program is completed. For details on a program concerning programming and erasure, see section 22.8.2, User Program Mode.

22.3 Memory MAT Configuration

The memory MATs of flash memory in this LSI consists of the 256-Kbyte/512-Kbyte/1-Mbyte user MAT and 16-Kbyte user boot MAT. The start addresses of the user MAT and user boot MAT are allocated to the same address. Therefore, when the program execution or data access is performed between the two memory MATs, the memory MATs must be switched by the flash MAT select register (FMATS).

The user MAT or user boot MAT can be read in all modes. However, the user boot MAT can be programmed or erased only in boot mode and programmer mode.

The size of the user MAT is different from that of the user boot MAT. Addresses which exceed the size of the 16-Kbyte user boot MAT should not be accessed. If an attempt is made, data is read as an undefined value.

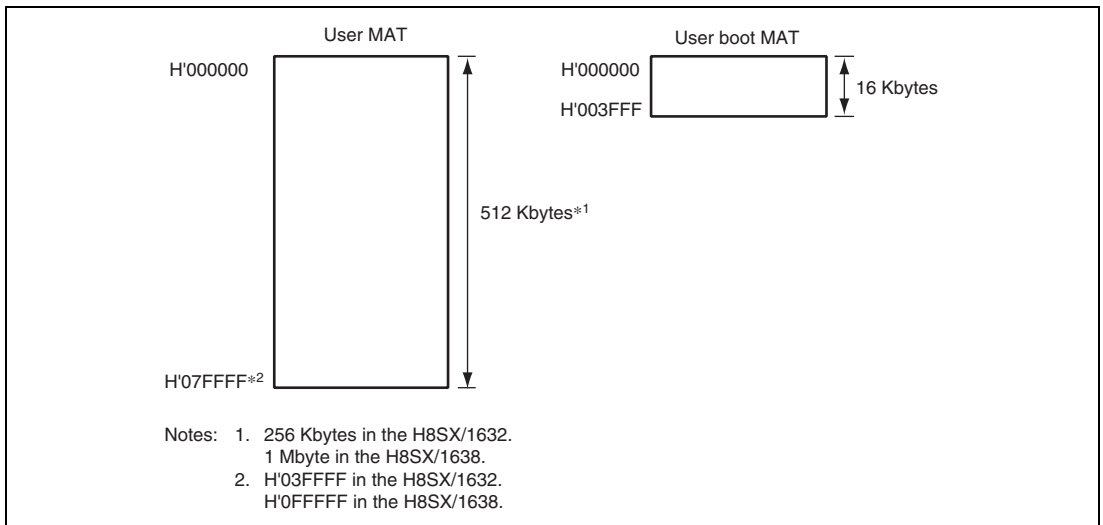

Figure 22.3 Memory MAT Configuration (H8SX/16xx_512K)

22.4 Block Structure

22.4.1 Block Diagram of H8SX/1632

Figure 22.4 (1) shows the block structure of the 256-Kbyte user MAT. The heavy-line frames indicate the erase blocks. The thin-line frames indicate the programming units and the values inside the frames stand for the addresses. The user MAT is divided into three 64-Kbyte blocks, one 32-Kbyte block, and eight 4-Kbyte blocks. The user MAT can be erased in these divided block units. Programming is done in 128-byte units starting from where the lower address is H'00 or H'80. RAM emulation can be performed in the eight 4-Kbyte blocks.

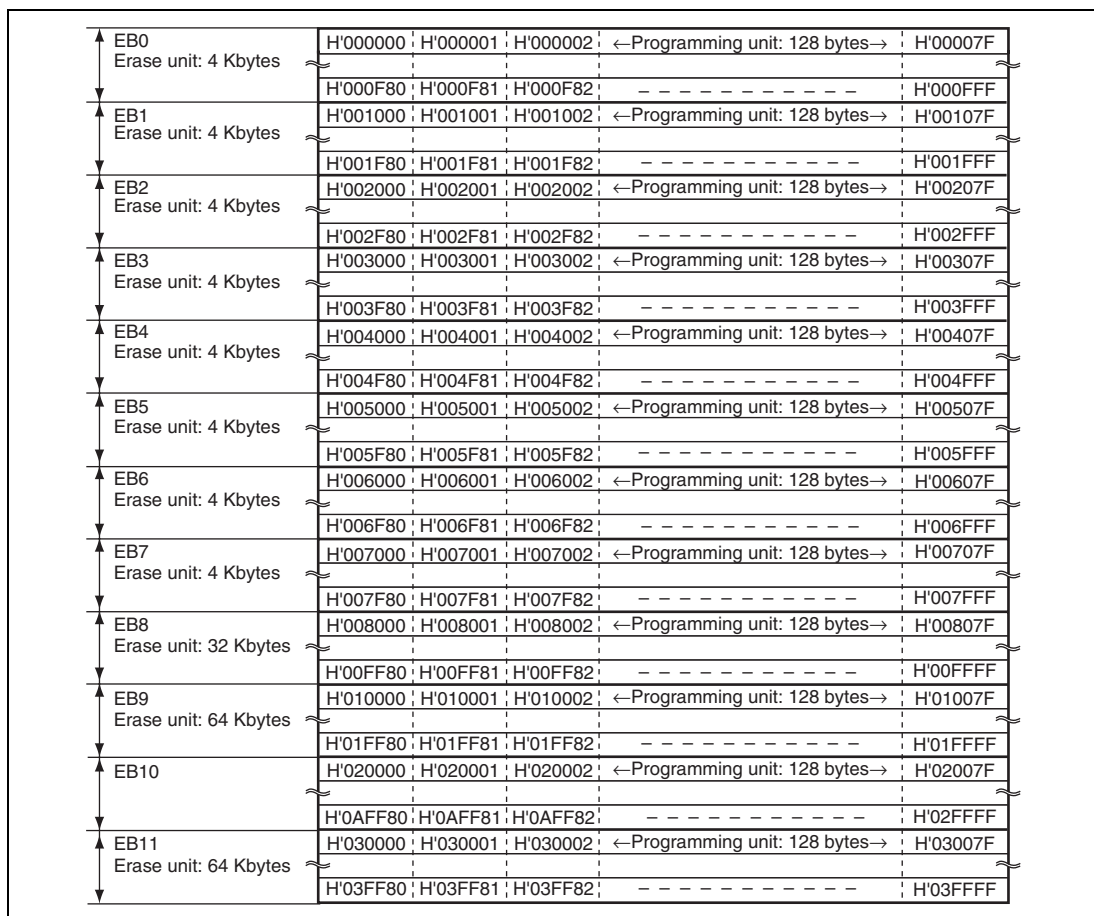

Figure 22.4 (1) User MAT Block Structure of H8SX/1632

22.4.2 Block Diagram of H8SX/1634

Figure 22.4 (2) shows the block structure of the 512-Kbyte user MAT. The heavy-line frames indicate the erase blocks. The thin-line frames indicate the programming units and the values inside the frames stand for the addresses. The user MAT is divided into seven 64-Kbyte blocks, one 32-Kbyte block, and eight 4-Kbyte blocks. The user MAT can be erased in these divided block units. Programming is done in 128-byte units starting from where the lower address is H'00 or H'80. RAM emulation can be performed in the eight 4-Kbyte blocks.

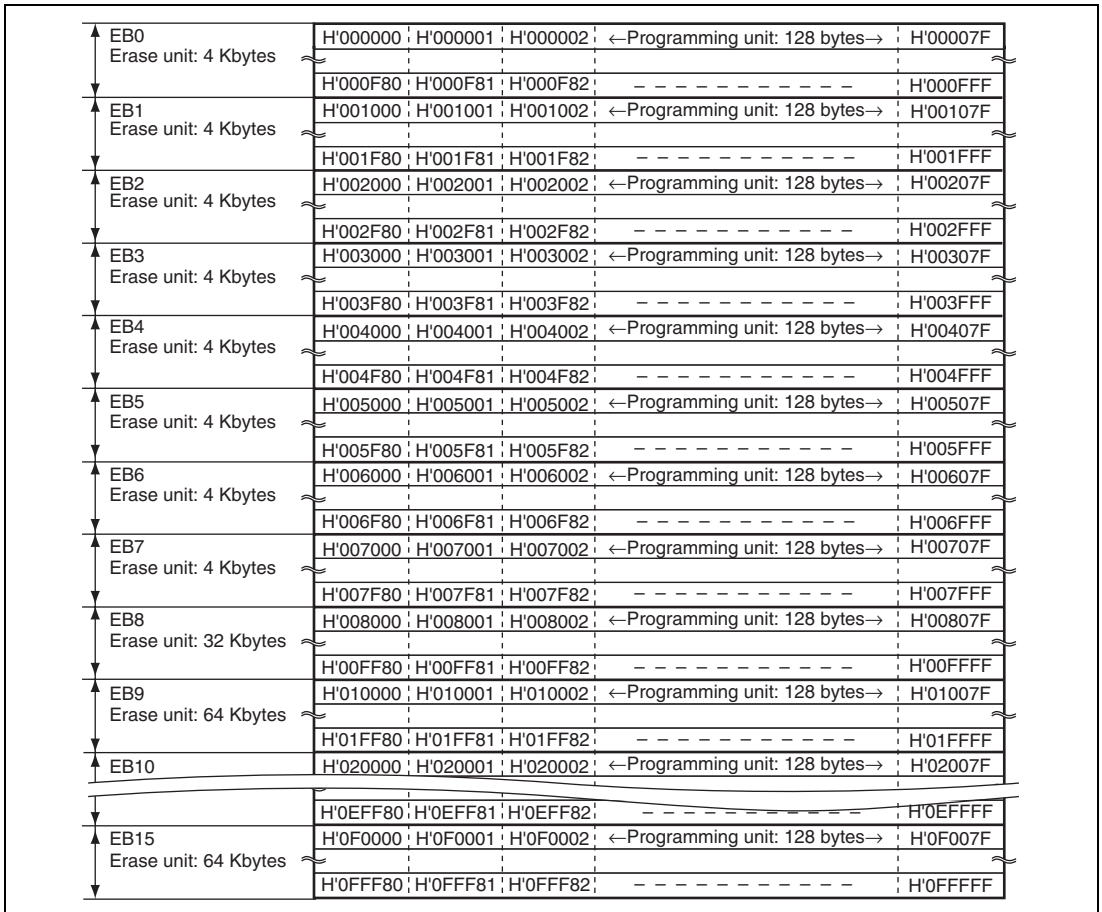

Figure 22.4 (2) User MAT Block Structure of H8SX/1634

22.4.3 Block Diagram of H8SX/1638

Figure 22.4 (3) shows the block structure of the 1-Mbyte user MAT. The heavy-line frames indicate the erase blocks. The thin-line frames indicate the programming units and the values inside the frames stand for the addresses. The user MAT is divided into fifteen 64-Kbyte blocks, one 32-Kbyte block, and eight 4-Kbyte blocks. The user MAT can be erased in these divided block units. Programming is done in 128-byte units starting from where the lower address is H'00 or H'80. RAM emulation can be performed in the eight 4-Kbyte blocks.

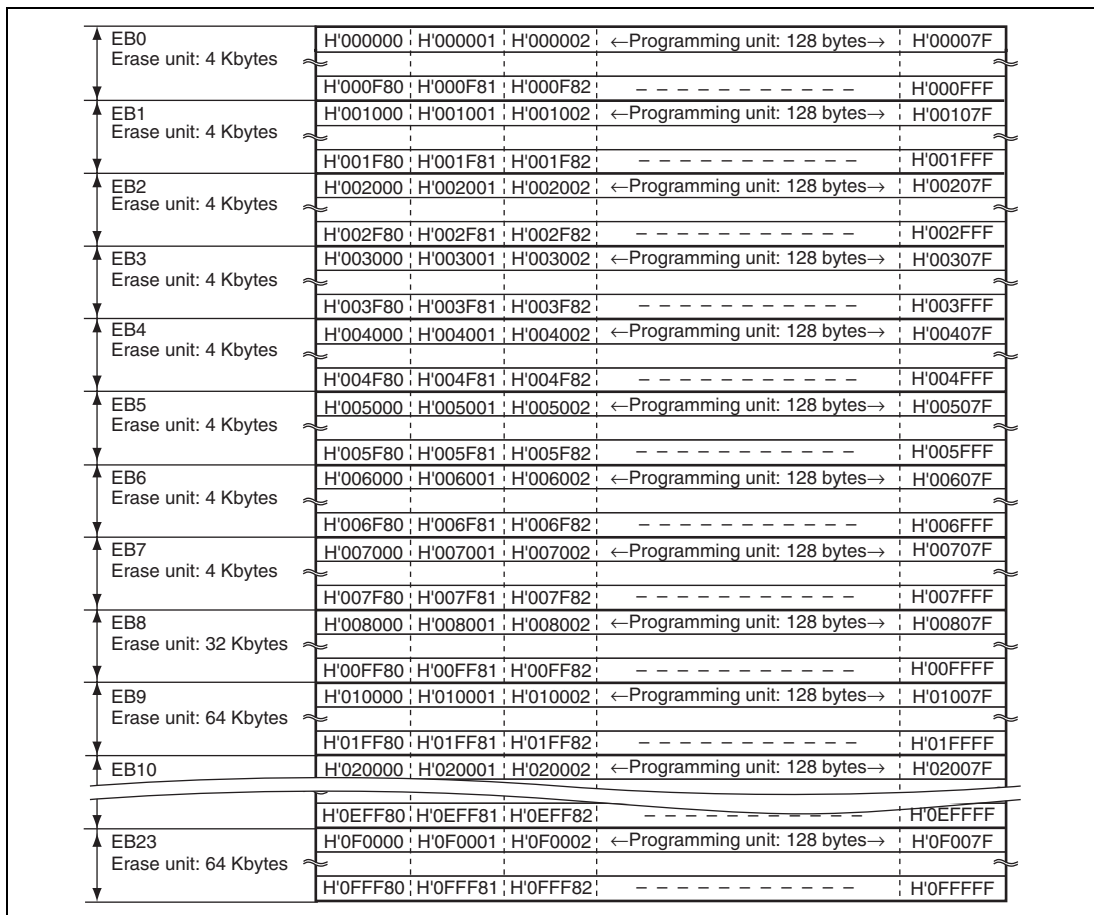

Figure 22.4 (3) User MAT Block Structure of H8SX/1638

22.5 Programming/Erasing Interface

Programming/erasure of the flash memory is done by downloading an on-chip programming/erasing program to the on-chip RAM and specifying the start address of the programming destination, the program data, and the erase block number using the programming/erasing interface registers and programming/erasing interface parameters.

The procedure program for user program mode and user boot mode is made by the user. Figure 22.5 shows the procedure for creating the procedure program. For details, see section 22.8.2, User Program Mode.

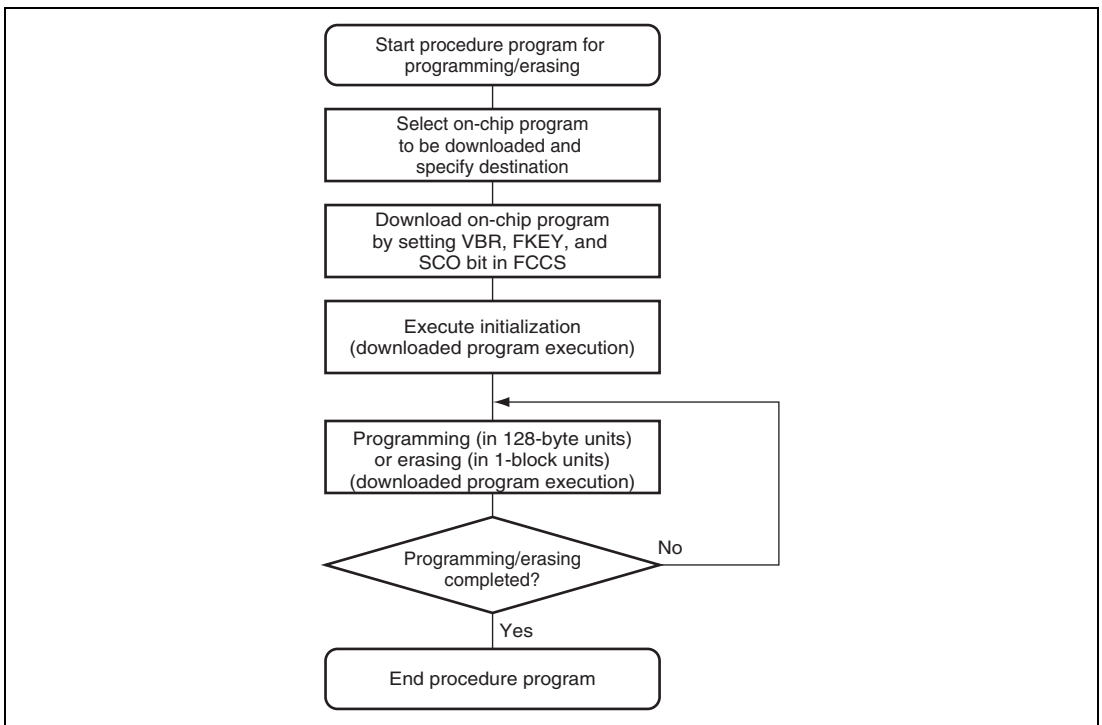

Figure 22.5 Procedure for Creating Procedure Program

(1) Selection of On-Chip Program to be Downloaded

This LSI has programming/erasing programs which can be downloaded to the on-chip RAM. The on-chip program to be downloaded is selected by the programming/erasing interface registers. The start address of the on-chip RAM where an on-chip program is downloaded is specified by the flash transfer destination address register (FTDAR).

(2) Download of On-Chip Program

The on-chip program is automatically downloaded by setting the flash key code register (FKEY) and the SCO bit in the flash code control/status register (FCCS) after initializing the vector base register (VBR). The memory MAT is replaced with the embedded program storage area during download. Since the memory MAT cannot be read during programming/erasing, the procedure program must be executed in a space other than the flash memory (for example, on-chip RAM). Since the download result is returned to the programming/erasing interface parameter, whether download is normally executed or not can be confirmed. The VBR contents can be changed after completion of download.

(3) Initialization of Programming/Erasure

A pulse with the specified period must be applied when programming or erasing. The specified pulse width is made by the method in which wait loop is configured by the CPU instruction. Accordingly, the operating frequency of the CPU needs to be set before programming/erasure. The operating frequency of the CPU is set by the programming/erasing interface parameter.

(4) Execution of Programming/Erasure

The start address of the programming destination and the program data are specified in 128-byte units when programming. The block to be erased is specified with the erase block number in erase-block units when erasing. Specifications of the start address of the programming destination, program data, and erase block number are performed by the programming/erasing interface parameters, and the on-chip program is initiated. The on-chip program is executed by using the JSR or BSR instruction and executing the subroutine call of the specified address in the on-chip RAM. The execution result is returned to the programming/erasing interface parameter.

The area to be programmed must be erased in advance when programming flash memory. All interrupts are disabled during programming/erasure.

(5) When Programming/Erasure is Executed Consecutively

When processing does not end by 128-byte programming or 1-block erasure, consecutive programming/erasure can be realized by updating the start address of the programming destination and program data, or the erase block number. Since the downloaded on-chip program is left in the on-chip RAM even after programming/erasure completes, download and initialization are not required when the same processing is executed consecutively.

22.6 Input/Output Pins

The flash memory is controlled through the input/output pins shown in table 22.2.

Table 22.2 Pin Configuration

Abbreviation	I/O	Function
RES	Input	Reset
EMLE	Input	On-chip emulator enable pin (EMLE = 0 for flash memory programming/erasure)
MD2 to MD0	Input	Set operating mode of this LSI
TxD4	Output	Serial transmit data output (used in boot mode)
RxD4	Input	Serial receive data input (used in boot mode)

22.7 Register Descriptions

The flash memory has the following registers.

Programming/Erasing Interface Registers:

- Flash code control/status register (FCCS)
- Flash program code select register (FPCS)
- Flash erase code select register (FECS)
- Flash key code register (FKEY)
- Flash MAT select register (FMATS)
- Flash transfer destination address register (FTDAR)

Programming/Erasing Interface Parameters:

- Download pass and fail result parameter (DPFR)
- Flash pass and fail result parameter (FPFR)
- Flash program/erase frequency parameter (FPEFEQ)
- Flash multipurpose address area parameter (FMPAR)
- Flash multipurpose data destination area parameter (FMPDR)
- Flash erase block select parameter (FEBS)
- RAM emulation register (RAMER)

There are several operating modes for accessing the flash memory. Respective operating modes, registers, and parameters are assigned to the user MAT and user boot MAT. The correspondence between operating modes and registers/parameters for use is shown in table 22.3.

Table 22.3 Registers/Parameters and Target Modes

Register/Parameter		Down- load	Initiali- zation	Program- ming	Erase Eras	Read	RAM Emulation
Programming/ erasing interface registers	FCCS	○	—	—	—	—	—
	FPCS	○	—	—	—	—	—
	FECS	○	—	—	—	—	—
	FKEY	○	—	○	○	—	—
	FMATS	—	—	○* ¹	○* ¹	○* ²	—
	FTDAR	○	—	—	—	—	—
Programming/ erasing interface parameters	DPFR	○	—	—	—	—	—
	FPFR	—	○	○	○	—	—
	FPEFEQ	—	○	—	—	—	—
	FMPAR	—	—	○	—	—	—
	FMPDR	—	—	○	—	—	—
	FEBS	—	—	—	○	—	—
RAM emulation	RAMER	—	—	—	—	—	○

Notes: 1. The setting is required when programming or erasing the user MAT in user boot mode.
2. The setting may be required according to the combination of initiation mode and read target memory MAT.

22.7.1 Programming/Erasing Interface Registers

The programming/erasing interface registers are 8-bit registers that can be accessed only in bytes. These registers are initialized by a reset.

(1) Flash Code Control/Status Register (FCCS)

FCCS monitors errors during programming/erasing the flash memory and requests the on-chip program to be downloaded to the on-chip RAM.

Bit	7	6	5	4	3	2	1	0
Bit Name	—	—	—	FLER	—	—	—	SCO
Initial Value	1	0	0	0	0	0	0	0
R/W	R	R	R	R	R	R	R	(R)/W*

Note: * This is a write-only bit. This bit is always read as 0.

Bit	Bit Name	Initial Value	R/W	Description
7	—	1	R	Reserved
6	—	0	R	These are read-only bits and cannot be modified.
5	—	0	R	
4	FLER	0	R	<p>Flash Memory Error</p> <p>Indicates that an error has occurred during programming or erasing the flash memory. When this bit is set to 1, the flash memory enters the error protection state. When this bit is set to 1, high voltage is applied to the internal flash memory. To reduce the damage to the flash memory, the reset must be released after the reset input period (period of $\overline{RES} = 0$) of at least 100 μs.</p> <p>0: Flash memory operates normally (Error protection is invalid)</p> <p>[Clearing condition]</p> <ul style="list-style-type: none"> At a reset <p>1: An error occurs during programming/erasing flash memory (Error protection is valid)</p> <p>[Setting conditions]</p> <ul style="list-style-type: none"> When an interrupt, such as NMI, occurs during programming/erasure. When the flash memory is read during programming/erasure (including a vector read and an instruction fetch). When the SLEEP instruction is executed during programming/erasure (including software standby mode). When a bus master other than the CPU, such as the DMAC and DTC, obtains bus mastership during programming/erasure.

Bit	Bit Name	Initial Value	R/W	Description
3 to 1	—	All 0	R	Reserved These are read-only bits and cannot be modified.
0	SCO	0	(R)/W*	<p>Source Program Copy Operation</p> <p>Requests the on-chip programming/erasing program to be downloaded to the on-chip RAM. When this bit is set to 1, the on-chip program which is selected by FPCS or FECS is automatically downloaded in the on-chip RAM area specified by FTDAR.</p> <p>In order to set this bit to 1, the RAM emulation mode must be canceled, H'A5 must be written to FKEY, and this operation must be executed in the on-chip RAM. Dummy read of FCCS must be executed twice immediately after setting this bit to 1. All interrupts must be disabled during download. This bit is cleared to 0 when download is completed.</p> <p>During program download initiated with this bit, particular processing which accompanies bank-switching of the program storage area is executed. Before a download request, initialize the VBR contents to H'00000000. After download is completed, the VBR contents can be changed.</p> <p>0: Download of the programming/erasing program is not requested.</p> <p>[Clearing condition]</p> <ul style="list-style-type: none"> • When download is completed <p>1: Download of the programming/erasing program is requested.</p> <p>[Setting conditions] (When all of the following conditions are satisfied)</p> <ul style="list-style-type: none"> • Not in RAM emulation mode (the RAMS bit in RAMER is cleared to 0) • H'A5 is written to FKEY • Setting of this bit is executed in the on-chip RAM

Note: * This is a write-only bit. This bit is always read as 0.

(2) Flash Program Code Select Register (FPCS)

FPCS selects the programming program to be downloaded.

Bit	7	6	5	4	3	2	1	0
Bit Name	—	—	—	—	—	—	—	PPVS
Initial Value	0	0	0	0	0	0	0	0
R/W	R	R	R	R	R	R	R	R/W

Bit	Bit Name	Initial Value	R/W	Description
7 to 1	—	All 0	R	Reserved These are read-only bits and cannot be modified.
0	PPVS	0	R/W	Program Pulse Verify Selects the programming program to be downloaded. 0: Programming program is not selected. [Clearing condition] When transfer is completed 1: Programming program is selected.

(3) Flash Erase Code Select Register (FECS)

FECS selects the erasing program to be downloaded.

Bit	7	6	5	4	3	2	1	0
Bit Name	—	—	—	—	—	—	—	EPVB
Initial Value	0	0	0	0	0	0	0	0
R/W	R	R	R	R	R	R	R	R/W

Bit	Bit Name	Initial Value	R/W	Description
7 to 1	—	All 0	R	Reserved These are read-only bits and cannot be modified.
0	EPVB	0	R/W	Erase Pulse Verify Block Selects the erasing program to be downloaded. 0: Erasing program is not selected. [Clearing condition] When transfer is completed 1: Erasing program is selected.

(4) Flash Key Code Register (FKEY)

FKEY is a register for software protection that enables to download the on-chip program and perform programming/erasure of the flash memory.

Bit	7	6	5	4	3	2	1	0
Bit Name	K7	K6	K5	K4	K3	K2	K1	K0
Initial Value	0	0	0	0	0	0	0	0
R/W	R/W	R/W	R/W	R/W	R/W	R/W	R/W	R/W

Bit	Bit Name	Initial Value	R/W	Description
7	K7	0	R/W	Key Code
6	K6	0	R/W	When H'A5 is written to FKEY, writing to the SCO bit in FCCS is enabled. When a value other than H'A5 is written, the SCO bit cannot be set to 1. Therefore, the on-chip program cannot be downloaded to the on-chip RAM.
5	K5	0	R/W	
4	K4	0	R/W	
3	K3	0	R/W	
2	K2	0	R/W	Only when H'5A is written can programming/erasure of the flash memory be executed. When a value other than H'5A is written, even if the programming/erasing program is executed, programming/erasure cannot be performed.
1	K1	0	R/W	
0	K0	0	R/W	

H'A5: Writing to the SCO bit is enabled. (The SCO bit cannot be set to 1 when FKEY is a value other than H'A5.)

H'5A: Programming/erasure of the flash memory is enabled. (When FKEY is a value other than H'A5, the software protection state is entered.)

H'00: Initial value

(5) Flash MAT Select Register (FMATS)

FMATS selects the user MAT or user boot MAT. Writing to FMATS should be done when a program in the on-chip RAM is being executed.

Bit	7	6	5	4	3	2	1	0
Bit Name	MS7	MS6	MS5	MS4	MS3	MS2	MS1	MS0
Initial Value	0/1*	0	0/1*	0	0/1*	0	0/1*	0
R/W	R/W	R/W	R/W	R/W	R/W	R/W	R/W	R/W

Note: * This bit is set to 1 in user boot mode, otherwise cleared to 0.

Bit	Bit Name	Initial Value	R/W	Description
7	MS7	0/1*	R/W	MAT Select
6	MS6	0	R/W	The memory MATs can be switched by writing a value to FMATS.
5	MS5	0/1*	R/W	When H'AA is written to FMATS, the user boot MAT is selected. When a value other than H'AA is written, the user MAT is selected. Switch the MATs following the memory MAT switching procedure in section 22.11, Switching between User MAT and User Boot MAT. The user boot MAT cannot be selected by FMATS in user programming mode. The user boot MAT can be selected in boot mode or programmer mode.
4	MS4	0	R/W	
3	MS3	0/1*	R/W	
2	MS2	0	R/W	
1	MS1	0/1*	R/W	
0	MS0	0	R/W	

H'AA: The user boot MAT is selected. (The user MAT is selected when FMATS is a value other than H'AA.)
(Initial value when initiated in user boot mode.)

H'00: The user MAT is selected.
(Initial value when initiated in a mode except for user boot mode.)

Note: * This bit is set to 1 in user boot mode, otherwise cleared to 0.

(6) Flash Transfer Destination Address Register (FTDAR)

FTDAR specifies the start address of the on-chip RAM at which to download an on-chip program. FTDAR must be set before setting the SCO bit in FCCS to 1.

Bit	7	6	5	4	3	2	1	0
Bit Name	TDER	TDA6	TDA5	TDA4	TDA3	TDA2	TDA1	TDA0
Initial Value	0	0	0	0	0	0	0	0
R/W	R/W	R/W	R/W	R/W	R/W	R/W	R/W	R/W

Bit	Bit Name	Initial Value	R/W	Description
7	TDER	0	R/W	<p>Transfer Destination Address Setting Error</p> <p>This bit is set to 1 when an error has occurred in setting the start address specified by bits TDA6 to TDA0.</p> <p>A start address error is determined by whether the value set in bits TDA6 to TDA0 is within the range of H'00 to H'02 when download is executed by setting the SCO bit in FCCS to 1. Make sure that this bit is cleared to 0 before setting the SCO bit to 1 and the value specified by bits TDA6 to TDA0 should be within the range of H'00 to H'02.</p> <p>0: The value specified by bits TDA6 to TDA0 is within the range.</p> <p>1: The value specified by bits TDA6 to TDA0 is between H'03 and H'FF and download has stopped.</p>
6	TDA6	0	R/W	Transfer Destination Address
5	TDA5	0	R/W	Specifies the on-chip RAM start address of the download destination. A value between H'00 and H'02, and up to 4 Kbytes can be specified as the start address of the on-chip RAM.
4	TDA4	0	R/W	
3	TDA3	0	R/W	
2	TDA2	0	R/W	
1	TDA1	0	R/W	H'01: H'FFA000 is specified as the start address.
0	TDA0	0	R/W	<p>H'02: H'FFB000 is specified as the start address.</p> <p>H'03 to H'7F: Setting prohibited.</p> <p>(Specifying a value from H'03 to H'7F sets the TDER bit to 1 and stops download of the on-chip program.)</p>

22.7.2 Programming/Erasing Interface Parameters

The programming/erasing interface parameters specify the operating frequency, storage place for program data, start address of programming destination, and erase block number, and exchanges the execution result. These parameters use the general registers of the CPU (ER0 and ER1) or the on-chip RAM area. The initial values of programming/erasing interface parameters are undefined at a reset or a transition to software standby mode.

Since registers of the CPU except for ER0 and ER1 are saved in the stack area during download of an on-chip program, initialization, programming, or erasing, allocate the stack area before performing these operations (the maximum stack size is 128 bytes). The return value of the processing result is written in R0. The programming/erasing interface parameters are used in download control, initialization before programming or erasing, programming, and erasing. Table 22.4 shows the usable parameters and target modes. The meaning of the bits in the flash pass and fail result parameter (FPFR) varies in initialization, programming, and erasure.

Table 22.4 Parameters and Target Modes

Parameter	Download	Initialization	Programming	Erasure	R/W	Initial Value	Allocation
DPFR	0	—	—	—	R/W	Undefined	On-chip RAM*
FPFR	0	0	0	0	R/W	Undefined	R0L of CPU
FPEFEQ	—	0	—	—	R/W	Undefined	ER0 of CPU
FMPAR	—	—	0	—	R/W	Undefined	ER1 of CPU
FMPDR	—	—	0	—	R/W	Undefined	ER0 of CPU
FEBS	—	—	—	0	R/W	Undefined	ER0 of CPU

Note: * A single byte of the start address of the on-chip RAM specified by FTDAR

(a) Download Control

The on-chip program is automatically downloaded by setting the SCO bit in FCCS to 1. The on-chip RAM area to download the on-chip program is the 4-Kbyte area starting from the start address specified by FTDAR. Download is by the programming/erasing interface registers, and the download pass and fail result parameter (DPFR) indicates the return value.

(b) Initialization before Programming/Erase

The on-chip program includes the initialization program. A pulse with the specified period must be applied when programming or erasing. The specified pulse width is made by the method in which wait loop is configured by the CPU instruction. Accordingly, the operating frequency of the CPU must be set. The initial program is set as a parameter of the programming/erasing program which has been downloaded to perform these settings.

(c) Programming

When the flash memory is programmed, the start address of the programming destination on the user MAT and the program data must be passed to the programming program.

The start address of the programming destination on the user MAT must be stored in general register ER1. This parameter is called the flash multipurpose address area parameter (FMPAR).

The program data is always in 128-byte units. When the program data does not satisfy 128 bytes, 128-byte program data is prepared by filling the dummy code (H'FF). The boundary of the start address of the programming destination on the user MAT is aligned at an address where the lower eight bits (A7 to A0) are H'00 or H'80.

The program data for the user MAT must be prepared in consecutive areas. The program data must be in a consecutive space which can be accessed using the MOV.B instruction of the CPU and is not in the flash memory space.

The start address of the area that stores the data to be written in the user MAT must be set in general register ER0. This parameter is called the flash multipurpose data destination area parameter (FMPDR).

For details on the programming procedure, see section 22.8.2, User Program Mode.

(d) Erasure

When the flash memory is erased, the erase block number on the user MAT must be passed to the erasing program which is downloaded.

The erase block number on the user MAT must be set in general register ER0. This parameter is called the flash erase block select parameter (FEBS).

One block is selected from the block numbers of 0 to 19 as the erase block number.

For details on the erasing procedure, see section 22.8.2, User Program Mode.

(1) Download Pass and Fail Result Parameter (DPFR: Single Byte of Start Address in On-Chip RAM Specified by FTDAR)

DPFR indicates the return value of the download result. The DPFR value is used to determine the download result.

Bit	7	6	5	4	3	2	1	0
Bit Name	—	—	—	—	—	SS	FK	SF

Bit	Bit Name	Initial Value	R/W	Description
7 to 3	—	—	—	Unused These bits return 0.
2	SS	—	R/W	Source Select Error Detect Only one type can be specified for the on-chip program which can be downloaded. When the program to be downloaded is not selected, more than two types of programs are selected, or a program which is not mapped is selected, an error occurs. 0: Download program selection is normal 1: Download program selection is abnormal
1	FK	—	R/W	Flash Key Register Error Detect Checks the FKEY value (H'A5) and returns the result. 0: FKEY setting is normal (H'A5) 1: FKEY setting is abnormal (value other than H'A5)
0	SF	—	R/W	Success/Fail Returns the download result. Reads back the program downloaded to the on-chip RAM and determines whether it has been transferred to the on-chip RAM. 0: Download of the program has ended normally (no error) 1: Download of the program has ended abnormally (error occurs)

(2) Flash Pass and Fail Parameter (FPFR: General Register R0L of CPU)

FPFR indicates the return values of the initialization, programming, and erasure results. The meaning of the bits in FPFR varies depending on the processing.

(a) Initialization before Programming/Erasure

FPFR indicates the return value of the initialization result.

Bit	7	6	5	4	3	2	1	0
Bit Name	—	—	—	—	—	—	FQ	SF

Bit	Bit Name	Initial Value	R/W	Description
7 to 2	—	—	—	Unused These bits return 0.
1	FQ	—	R/W	Frequency Error Detect Compares the specified CPU operating frequency with the operating frequencies supported by this LSI, and returns the result. 0: Setting of operating frequency is normal 1: Setting of operating frequency is abnormal
0	SF	—	R/W	Success/Fail Returns the initialization result. 0: Initialization has ended normally (no error) 1: Initialization has ended abnormally (error occurs)

(b) Programming

FPFR indicates the return value of the programming result.

Bit	7	6	5	4	3	2	1	0
Bit Name	—	MD	EE	FK	—	WD	WA	SF

Bit	Bit Name	Initial Value	R/W	Description
7	—	—	—	Unused Returns 0.
6	MD	—	R/W	<p>Programming Mode Related Setting Error Detect</p> <p>Detects the error protection state and returns the result. When the error protection state is entered, this bit is set to 1. Whether the error protection state is entered or not can be confirmed with the FLER bit in FCCS. For conditions to enter the error protection state, see section 22.9.3, Error Protection.</p> <p>0: Normal operation (FLER = 0) 1: Error protection state, and programming cannot be performed (FLER = 1)</p>
5	EE	—	R/W	<p>Programming Execution Error Detect</p> <p>Writes 1 to this bit when the specified data could not be written because the user MAT was not erased. If this bit is set to 1, there is a high possibility that the user MAT has been written to partially. In this case, after removing the error factor, erase the user MAT. If FMATS is set to H'AA and the user boot MAT is selected, an error occurs when programming is performed. In this case, both the user MAT and user boot MAT have not been written to. Programming the user boot MAT should be performed in boot mode or programmer mode.</p> <p>0: Programming has ended normally 1: Programming has ended abnormally (programming result is not guaranteed)</p>

Bit	Bit Name	Initial Value	R/W	Description
4	FK	—	R/W	Flash Key Register Error Detect Checks the FKEY value (H'5A) before programming starts, and returns the result. 0: FKEY setting is normal (H'5A) 1: FKEY setting is abnormal (value other than H'5A)
3	—	—	—	Unused Returns 0.
2	WD	—	R/W	Write Data Address Detect When an address not in the flash memory area is specified as the start address of the storage destination for the program data, an error occurs. 0: Setting of the start address of the storage destination for the program data is normal 1: Setting of the start address of the storage destination for the program data is abnormal
1	WA	—	R/W	Write Address Error Detect When the following items are specified as the start address of the programming destination, an error occurs. <ul style="list-style-type: none"> An area other than flash memory The specified address is not aligned with the 128-byte boundary (lower eight bits of the address are other than H'00 and H'80) 0: Setting of the start address of the programming destination is normal 1: Setting of the start address of the programming destination is abnormal
0	SF	—	R/W	Success/Fail Returns the programming result. 0: Programming has ended normally (no error) 1: Programming has ended abnormally (error occurs)

(c) Erasure

FPFR indicates the return value of the erasure result.

Bit	7	6	5	4	3	2	1	0
Bit Name	—	MD	EE	FK	EB	—	—	SF

Bit	Bit Name	Initial Value	R/W	Description
7	—	—	—	Unused Returns 0.
6	MD	—	R/W	Erasure Mode Related Setting Error Detect Detects the error protection state and returns the result. When the error protection state is entered, this bit is set to 1. Whether the error protection state is entered or not can be confirmed with the FLER bit in FCCS. For conditions to enter the error protection state, see section 22.9.3, Error Protection. 0: Normal operation (FLER = 0) 1: Error protection state, and programming cannot be performed (FLER = 1)
5	EE	—	R/W	Erasure Execution Error Detect Returns 1 when the user MAT could not be erased or when the flash memory related register settings are partially changed. If this bit is set to 1, there is a high possibility that the user MAT has been erased partially. In this case, after removing the error factor, erase the user MAT. If FMATS is set to H'AA and the user boot MAT is selected, an error occurs when erasure is performed. In this case, both the user MAT and user boot MAT have not been erased. Erasing of the user boot MAT should be performed in boot mode or programmer mode. 0: Erasure has ended normally 1: Erasure has ended abnormally

Bit	Bit Name	Initial Value	R/W	Description
4	FK	—	R/W	Flash Key Register Error Detect Checks the FKEY value (H'5A) before erasure starts, and returns the result. 0: FKEY setting is normal (H'5A) 1: FKEY setting is abnormal (value other than H'5A)
3	EB	—	R/W	Erase Block Select Error Detect Checks whether the specified erase block number is in the block range of the user MAT, and returns the result. 0: Setting of erase block number is normal 1: Setting of erase block number is abnormal
2, 1	—	—	—	Unused These bits return 0.
0	SF	—	R/W	Success/Fail Indicates the erasure result. 0: Erasure has ended normally (no error) 1: Erasure has ended abnormally (error occurs)

(3) Flash Program/Erase Frequency Parameter (FPEFEQ: General Register ER0 of CPU)

FPEFEQ sets the operating frequency of the CPU. The operating frequency available in this LSI ranges from 8 MHz to 50 MHz.

Bit	31	30	29	28	27	26	25	24
Bit Name	—	—	—	—	—	—	—	—
Bit	23	22	21	20	19	18	17	16
Bit Name	—	—	—	—	—	—	—	—
Bit	15	14	13	12	11	10	9	8
Bit Name	F15	F14	F13	F12	F11	F10	F9	F8
Bit	7	6	5	4	3	2	1	0
Bit Name	F7	F6	F5	F4	F3	F2	F1	F0

Bit	Bit Name	Initial Value	R/W	Description
31 to 16	—	—	—	Unused These bits should be cleared to 0.
15 to 0	F15 to F0	—	R/W	<p>Frequency Set</p> <p>These bits set the operating frequency of the CPU. When the PLL multiplication function is used, set the multiplied frequency. The setting value must be calculated as follows:</p> <ol style="list-style-type: none"> 1. The operating frequency shown in MHz units must be rounded in a number of three decimal places and be shown in a number of two decimal places. 2. The value multiplied by 100 is converted to the binary digit and is written to FPEFEQ (general register ER0). <p>For example, when the operating frequency of the CPU is 35.000 MHz, the value is as follows:</p> <ol style="list-style-type: none"> 1. The number of three decimal places of 35.000 is rounded. 2. The formula of $35.00 \times 100 = 3500$ is converted to the binary digit and B'0000 1101 1010 1100 (H'0DAC) is set to ER0.

(4) Flash Multipurpose Address Area Parameter (FMPAR: General Register ER1 of CPU)

FMPAR stores the start address of the programming destination on the user MAT.

When an address in an area other than the flash memory is set, or the start address of the programming destination is not aligned with the 128-byte boundary, an error occurs. The error occurrence is indicated by the WA bit in FPCR.

Bit	31	30	29	28	27	26	25	24
Bit Name	MOA31	MOA30	MOA29	MOA28	MOA27	MOA26	MOA25	MOA24
Bit	23	22	21	20	19	18	17	16
Bit Name	MOA23	MOA22	MOA21	MOA20	MOA19	MOA18	MOA17	MOA16
Bit	15	14	13	12	11	10	9	8
Bit Name	MOA15	MOA14	MOA13	MOA12	MOA11	MOA10	MOA9	MOA8
Bit	7	6	5	4	3	2	1	0
Bit Name	MOA7	MOA6	MOA5	MOA4	MOA3	MOA2	MOA1	MOA0

Bit	Bit Name	Initial Value	R/W	Description
31 to 0	MOA31 to MOA0	—	R/W	These bits store the start address of the programming destination on the user MAT. Consecutive 128-byte programming is executed starting from the specified start address of the user MAT. Therefore, the specified start address of the programming destination becomes a 128-byte boundary, and MOA6 to MOA0 are always cleared to 0.

(5) Flash Multipurpose Data Destination Parameter (FMPDR: General Register ER0 of CPU)

FMPDR stores the start address in the area which stores the data to be programmed in the user MAT.

When the storage destination for the program data is in flash memory, an error occurs. The error occurrence is indicated by the WD bit in FPFR.

Bit	31	30	29	28	27	26	25	24
Bit Name	MOD31	MOD30	MOD29	MOD28	MOD27	MOD26	MOD25	MOD24
Bit	23	22	21	20	19	18	17	16
Bit Name	MOD23	MOD22	MOD21	MOD20	MOD19	MOD18	MOD17	MOD16
Bit	15	14	13	12	11	10	9	8
Bit Name	MOD15	MOD14	MOD13	MOD12	MOD11	MOD10	MOD9	MOD8
Bit	7	6	5	4	3	2	1	0
Bit Name	MOD7	MOD6	MOD5	MOD4	MOD3	MOD2	MOD1	MOD0

Bit	Bit Name	Initial Value	R/W	Description
31 to 0	MOD31 to MOD0	—	R/W	These bits store the start address of the area which stores the program data for the user MAT. Consecutive 128-byte data is programmed to the user MAT starting from the specified start address.

(6) Flash Erase Block Select Parameter (FEBS: General Register ER0 of CPU)

• H8SX/1632

FEBS specifies the erase block number. Settable values range from 0 to 11 (H'0000 to H'000B). A value of 0 corresponds to block EB0 and a value of 11 corresponds to block EB11. An error occurs when a value over the range (from 0 to 11) is set.

• H8SX/1634

FEBS specifies the erase block number. Settable values range from 0 to 15 (H'0000 to H'000F). A value of 0 corresponds to block EB0 and a value of 15 corresponds to block EB15. An error occurs when a value over the range (from 0 to 15) is set.

• H8SX/1638

FEBS specifies the erase block number. Settable values range from 0 to 23 (H'0000 to H'0017). A value of 0 corresponds to block EB0 and a value of 23 corresponds to block EB23. An error occurs when a value over the range (from 0 to 23) is set.

Bit	31	30	29	28	27	26	25	24
Bit Name								
Initial Value	—	—	—	—	—	—	—	—
R/W	R/W	R/W	R/W	R/W	R/W	R/W	R/W	R/W
Bit	23	22	21	20	19	18	17	16
Bit Name								
Initial Value	—	—	—	—	—	—	—	—
R/W	R/W	R/W	R/W	R/W	R/W	R/W	R/W	R/W
Bit	15	14	13	12	11	10	9	8
Bit Name								
Initial Value	—	—	—	—	—	—	—	—
R/W	R/W	R/W	R/W	R/W	R/W	R/W	R/W	R/W
Bit	7	6	5	4	3	2	1	0
Bit Name								
Initial Value	—	—	—	—	—	—	—	—
R/W	R/W	R/W	R/W	R/W	R/W	R/W	R/W	R/W

22.7.3 RAM Emulation Register (RAMER)

RAMER specifies the user MAT area overlaid with part of the on-chip RAM (H'FFFA000 to H'FFFAFFF) when performing emulation of programming the user MAT. RAMER should be set in user mode or user program mode. To ensure dependable emulation, the memory MAT to be emulated must not be accessed immediately after changing the RAMER contents. When accessed at such a timing, correct operation is not guaranteed.

Bit	7	6	5	4	3	2	1	0
Bit Name	—	—	—	—	RAMS	RAM2	RAM1	RAM0
Initial Value	0	0	0	0	0	0	0	0
R/W	R	R	R	R	R/W	R/W	R/W	R/W

Bit	Bit Name	Initial Value	R/W	Description
7 to 4	—	0	R	Reserved These are read-only bits and cannot be modified.
3	RAMS	0	R/W	RAM Select Selects the function which emulates the flash memory using the on-chip RAM. 0: Disables RAM emulation function 1: Enables RAM emulation function (all blocks of the user MAT are protected against programming and erasing)
2	RAM2	0	R/W	Flash Memory Area Select
1	RAM1	0	R/W	These bits select the user MAT area overlaid with the on-chip RAM when RAMS = 1. The following areas correspond to the 4-Kbyte erase blocks.
0	RAM0	0	R/W	
				000: H'000000 to H'000FFF (EB0)
				001: H'001000 to H'001FFF (EB1)
				010: H'002000 to H'002FFF (EB2)
				011: H'003000 to H'003FFF (EB3)
				100: H'004000 to H'004FFF (EB4)
				101: H'005000 to H'005FFF (EB5)
				110: H'006000 to H'006FFF (EB6)
				111: H'007000 to H'007FFF (EB7)

22.8 On-Board Programming Mode

When the mode pins (MD0, MD1, and MD2) are set to on-board programming mode and the reset start is executed, a transition is made to on-board programming mode in which the on-chip flash memory can be programmed/erased. On-board programming mode has three operating modes: boot mode, user boot mode, and user program mode.

Table 22.5 shows the pin setting for each operating mode. For details on the state transition of each operating mode for flash memory, see figure 22.2.

Table 22.5 On-Board Programming Mode Setting

Mode Setting	EMLE	MD2	MD1	MD0
User boot mode	0	0	0	1
Boot mode	0	0	1	0
User program mode	0	1	1	0
	0	1	1	1

22.8.1 Boot Mode

Boot mode executes programming/erasure of the user MAT or user boot MAT by means of the control command and program data transmitted from the externally connected host via the on-chip SCI_4.

In boot mode, the tool for transmitting the control command and program data, and the program data must be prepared in the host. The serial communication mode is set to asynchronous mode. The system configuration in boot mode is shown in figure 22.6. Interrupts are ignored in boot mode. Configure the user system so that interrupts do not occur.

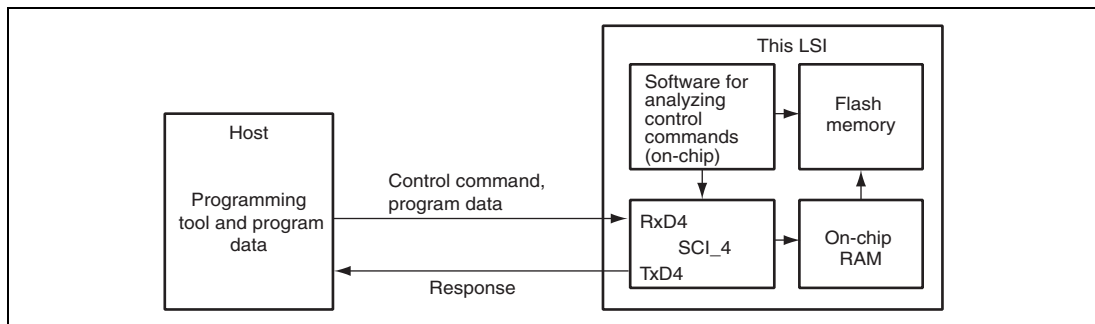

Figure 22.6 System Configuration in Boot Mode

(1) Serial Interface Setting by Host

The SCI_4 is set to asynchronous mode, and the serial transmit/receive format is set to 8-bit data, one stop bit, and no parity.

When a transition to boot mode is made, the boot program embedded in this LSI is initiated.

When the boot program is initiated, this LSI measures the low period of asynchronous serial communication data (H'00) transmitted consecutively by the host, calculates the bit rate, and adjusts the bit rate of the SCI_4 to match that of the host.

When bit rate adjustment is completed, this LSI transmits 1 byte of H'00 to the host as the bit adjustment end sign. When the host receives this bit adjustment end sign normally, it transmits 1 byte of H'55 to this LSI. When reception is not executed normally, initiate boot mode again. The bit rate may not be adjusted within the allowable range depending on the combination of the bit rate of the host and the system clock frequency of this LSI. Therefore, the transfer bit rate of the host and the system clock frequency of this LSI must be as shown in table 22.6.

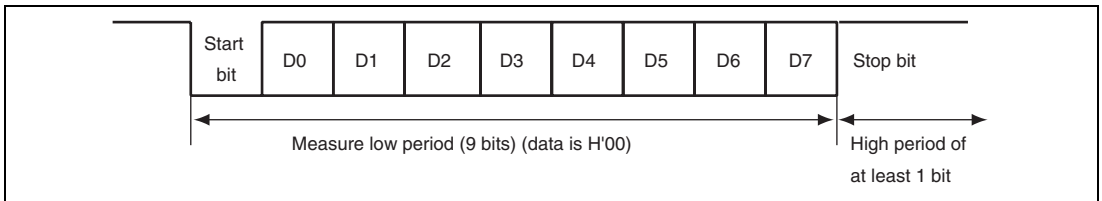

Figure 22.7 Automatic-Bit-Rate Adjustment Operation

Table 22.6 System Clock Frequency for Automatic-Bit-Rate Adjustment

Bit Rate of Host	System Clock Frequency of This LSI
9,600 bps	8 to 18 MHz
19,200 bps	8 to 18 MHz

(2) State Transition Diagram

The state transition after boot mode is initiated is shown in figure 22.8.

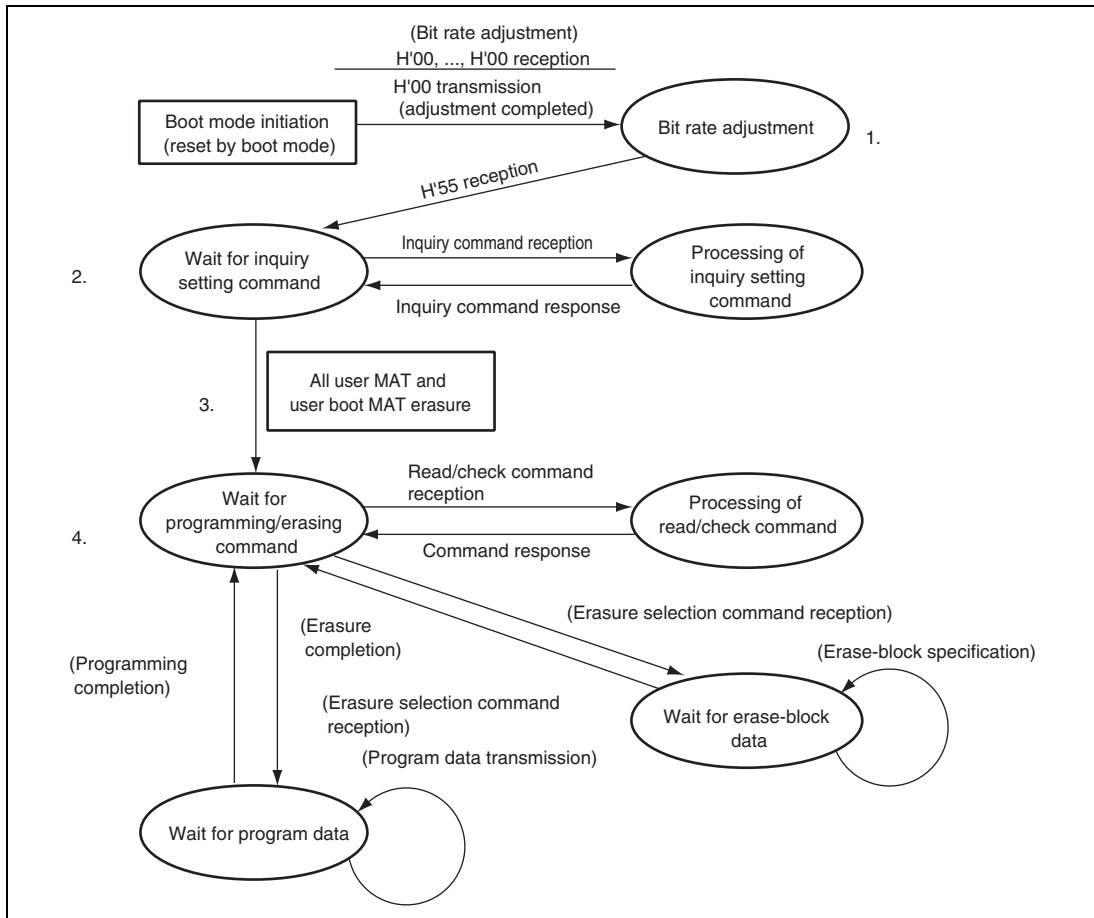

Figure 22.8 Boot Mode State Transition Diagram

1. After boot mode is initiated, the bit rate of the SCI_4 is adjusted with that of the host.
2. Inquiry information about the size, configuration, start address, and support status of the user MAT is transmitted to the host.
3. After inquiries have finished, all user MAT and user boot MAT are automatically erased.
4. When the program preparation notice is received, the state of waiting for program data is entered. The start address of the programming destination and program data must be transmitted after the programming command is transmitted. When programming is finished, the start address of the programming destination must be set to H'FFFFFFF and transmitted. Then the state of waiting for program data is returned to the state of waiting for programming/erasing command. When the erasure preparation notice is received, the state of waiting for erase block data is entered. The erase block number must be transmitted after the erasing command is transmitted. When the erasure is finished, the erase block number must be set to H'FF and transmitted. Then the state of waiting for erase block data is returned to the state of waiting for programming/erasing command. Erasure must be executed when the specified block is programmed without a reset start after programming is executed in boot mode. When programming can be executed by only one operation, all blocks are erased before entering the state of waiting for programming/erasing command or another command. Thus, in this case, the erasing operation is not required. The commands other than the programming/erasing command perform sum check, blank check (erasure check), and memory read of the user MAT/user boot MAT and acquisition of current status information.

Memory read of the user MAT/user boot MAT can only read the data programmed after all user MAT/user boot MAT has automatically been erased. No other data can be read.

22.8.2 User Program Mode

Programming/erasure of the user MAT is executed by downloading an on-chip program. The user boot MAT cannot be programmed/erased in user program mode. The programming/erasing flow is shown in figure 22.9.

Since high voltage is applied to the internal flash memory during programming/erasure, a transition to the reset state or hardware standby mode must not be made during programming/erasure. A transition to the reset state or hardware standby mode during programming/erasure may damage the flash memory. If a reset is input, the reset must be released after the reset input period (period of $\overline{RES} = 0$) of at least 100 μs .

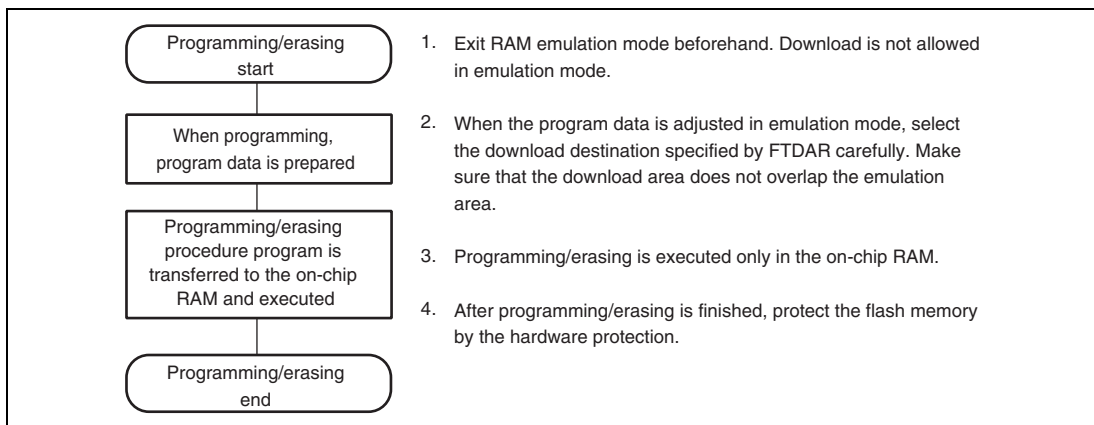

Figure 22.9 Programming/Erasing Flow

(1) On-Chip RAM Address Map when Programming/Erase is Executed

Parts of the procedure program that is made by the user, like download request, programming/erase procedure, and decision of the result, must be executed in the on-chip RAM. Since the on-chip program to be downloaded is embedded in the on-chip RAM, make sure the on-chip program and procedure program do not overlap. Figure 22.10 shows the area of the on-chip program to be downloaded.

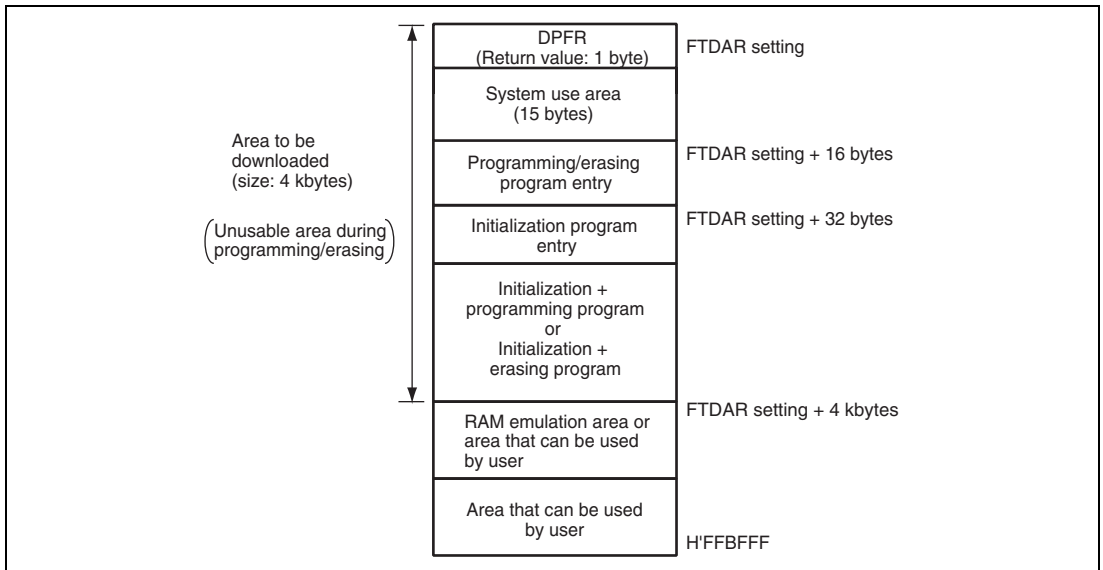

Figure 22.10 RAM Map when Programming/Erase is Executed

(2) Programming Procedure in User Program Mode

The procedures for download of the on-chip program, initialization, and programming are shown in figure 22.11.

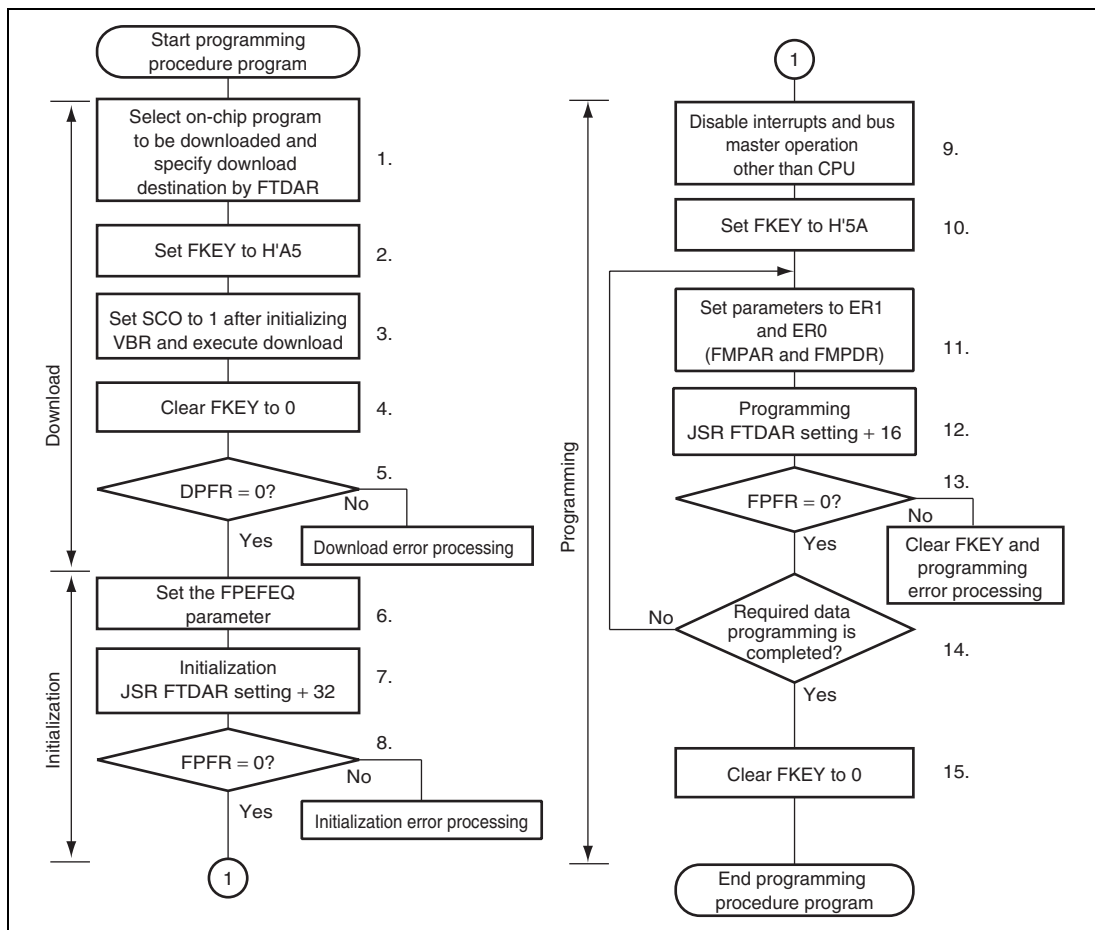

Figure 22.11 Programming Procedure in User Program Mode

The procedure program must be executed in an area other than the flash memory to be programmed. Setting the SCO bit in FCCS to 1 to request download must be executed in the on-chip RAM. The area that can be executed in the steps of the procedure program (on-chip RAM, user MAT, and external space) is shown in section 22.8.4, On-Chip Program and Storable Area for Program Data. The following description assumes that the area to be programmed on the user MAT is erased and that program data is prepared in the consecutive area.

The program data for one programming operation is always 128 bytes. When the program data exceeds 128 bytes, the start address of the programming destination and program data parameters are updated in 128-byte units and programming is repeated. When the program data is less than 128 bytes, invalid data is filled to prepare 128-byte program data. If the invalid data to be added is H'FF, the program processing time can be shortened.

1. Select the on-chip program to be downloaded and the download destination. When the PPVS bit in FPCS is set to 1, the programming program is selected. Several programming/erasing programs cannot be selected at one time. If several programs are selected, a download error is returned to the SS bit in the DPFR parameter. The on-chip RAM start address of the download destination is specified by FTDAR.
2. Write H'A5 in FKEY. If H'A5 is not written to FKEY, the SCO bit in FCCS cannot be set to 1 to request download of the on-chip program.
3. After initializing VBR to H'00000000, set the SCO bit to 1 to execute download. To set the SCO bit to 1, all of the following conditions must be satisfied.
 - RAM emulation mode has been canceled.
 - H'A5 is written to FKEY.
 - Setting the SCO bit is executed in the on-chip RAM.

When the SCO bit is set to 1, download is started automatically. Since the SCO bit is cleared to 0 when the procedure program is resumed, the SCO bit cannot be confirmed to be 1 in the procedure program. The download result can be confirmed by the return value of the DPFR parameter. To prevent incorrect decision, before setting the SCO bit to 1, set one byte of the on-chip RAM start address specified by FTDAR, which becomes the DPFR parameter, to a value other than the return value (e.g. H'FF). Since particular processing that is accompanied by bank switching as described below is performed when download is executed, initialize the VBR contents to H'00000000. Dummy read of FCCS must be performed twice immediately after the SCO bit is set to 1.

- The user-MAT space is switched to the on-chip program storage area.
- After the program to be downloaded and the on-chip RAM start address specified by FTDAR are checked, they are transferred to the on-chip RAM.
- FPCS, FECS, and the SCO bit in FCCS are cleared to 0.

- The return value is set in the DPFR parameter.
 - After the on-chip program storage area is returned to the user-MAT space, the procedure program is resumed. After that, VBR can be set again.
 - The values of general registers of the CPU are held.
 - During download, no interrupts can be accepted. However, since the interrupt requests are held, when the procedure program is resumed, the interrupts are requested.
 - To hold a level-detection interrupt request, the interrupt must continue to be input until the download is completed.
 - Allocate a stack area of 128 bytes at the maximum in the on-chip RAM before setting the SCO bit to 1.
 - If access to the flash memory is requested by the DMAC or DTC during download, the operation cannot be guaranteed. Make sure that an access request by the DMAC or DTC is not generated.
4. FKEY is cleared to H'00 for protection.
 5. The download result must be confirmed by the value of the DPFR parameter. Check the value of the DPFR parameter (one byte of start address of the download destination specified by FTDAR). If the value of the DPFR parameter is H'00, download has been performed normally. If the value is not H'00, the source that caused download to fail can be investigated by the description below.
 - If the value of the DPFR parameter is the same as that before downloading, the setting of the start address of the download destination in FTDAR may be abnormal. In this case, confirm the setting of the TDER bit in FTDAR.
 - If the value of the DPFR parameter is different from that before downloading, check the SS bit or FK bit in the DPFR parameter to confirm the download program selection and FKEY setting, respectively.
 6. The operating frequency of the CPU is set in the FPEFEQ parameter for initialization. The settable operating frequency of the FPEFEQ parameter ranges from 8 to 50 MHz. When the frequency is set otherwise, an error is returned to the FPFR parameter of the initialization program and initialization is not performed. For details on setting the frequency, see section 22.7.2 (3), Flash Program/Erase Frequency Parameter (FPEFEQ: General Register ER0 of CPU).

7. Initialization is executed. The initialization program is downloaded together with the programming program to the on-chip RAM. The entry point of the initialization program is at the address which is 32 bytes after #DLTOP (start address of the download destination specified by FTDAR). Call the subroutine to execute initialization by using the following steps.

```
MOV.L #DLTOP+32,ER2      ; Set entry address to ER2
JSR   @ER2              ; Call initialization routine
NOP
```

- The general registers other than ER0 and ER1 are held in the initialization program.
 - R0L is a return value of the FPFPR parameter.
 - Since the stack area is used in the initialization program, a stack area of 128 bytes at the maximum must be allocated in RAM.
 - Interrupts can be accepted during execution of the initialization program. Make sure the program storage area and stack area in the on-chip RAM and register values are not overwritten.
8. The return value in the initialization program, the FPFPR parameter is determined.
 9. All interrupts and the use of a bus master other than the CPU are disabled during programming/erasure. The specified voltage is applied for the specified time when programming or erasing. If interrupts occur or the bus mastership is moved to other than the CPU during programming/erasure, causing a voltage exceeding the specifications to be applied, the flash memory may be damaged. Therefore, interrupts are disabled by setting bit 7 (I bit) in the condition code register (CCR) to B'1 in interrupt control mode 0 and by setting bits 2 to 0 (I2 to I0 bits) in the extend register (EXR) to B'111 in interrupt control mode 2. Accordingly, interrupts other than NMI are held and not executed. Configure the user system so that NMI interrupts do not occur. The interrupts that are held must be executed after all programming completes. When the bus mastership is moved to other than the CPU, such as to the DMAC or DTC, the error protection state is entered. Therefore, make sure the DMAC does not acquire the bus.
 10. FKEY must be set to H'5A and the user MAT must be prepared for programming.
 11. The parameters required for programming are set. The start address of the programming destination on the user MAT (FMPAR parameter) is set in general register ER1. The start address of the program data storage area (FMPDR parameter) is set in general register ER0.
 - Example of FMPAR parameter setting: When an address other than one in the user MAT area is specified for the start address of the programming destination, even if the programming program is executed, programming is not executed and an error is returned to the FPFPR parameter. Since the program data for one programming operation is 128 bytes, the lower eight bits of the address must be H'00 or H'80 to be aligned with the 128-byte boundary.

— Example of FMPDR parameter setting: When the storage destination for the program data is flash memory, even if the programming routine is executed, programming is not executed and an error is returned to the FMPDR parameter. In this case, the program data must be transferred to the on-chip RAM and then programming must be executed.

12. Programming is executed. The entry point of the programming program is at the address which is 16 bytes after #DLTOP (start address of the download destination specified by FTDAR). Call the subroutine to execute programming by using the following steps.

```
MOV.L    #DLTOP+16,ER2    ; Set entry address to ER2
JSR      @ER2             ; Call programming routine
NOP
```

— The general registers other than ER0 and ER1 are held in the programming program.

— R0L is a return value of the FMPDR parameter.

— Since the stack area is used in the programming program, a stack area of 128 bytes at the maximum must be allocated in RAM.

13. The return value in the programming program, the FMPDR parameter is determined.
14. Determine whether programming of the necessary data has finished. If more than 128 bytes of data are to be programmed, update the FMPAR and FMPDR parameters in 128-byte units, and repeat steps 11 to 14. Increment the programming destination address by 128 bytes and update the programming data pointer correctly. If an address which has already been programmed is written to again, not only will a programming error occur, but also flash memory will be damaged.
15. After programming finishes, clear FKEY and specify software protection. If this LSI is restarted by a reset immediately after programming has finished, secure the reset input period (period of $\overline{\text{RES}} = 0$) of at least 100 μs .

(3) Erasing Procedure in User Program Mode

The procedures for download of the on-chip program, initialization, and erasing are shown in figure 22.12.

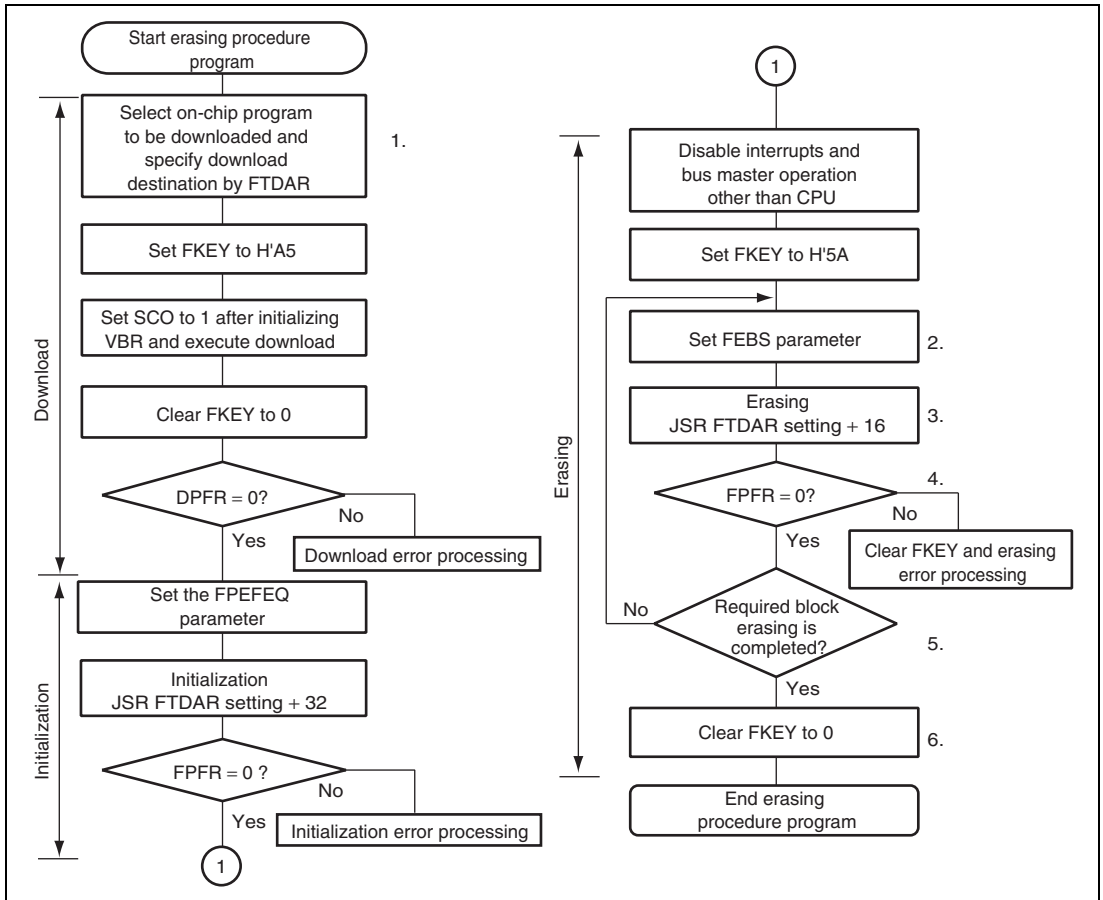

Figure 22.12 Erasing Procedure in User Program Mode

The procedure program must be executed in an area other than the user MAT to be erased. Setting the SCO bit in FCCS to 1 to request download must be executed in the on-chip RAM. The area that can be executed in the steps of the procedure program (on-chip RAM, user MAT, and external space) is shown in section 22.8.4, On-Chip Program and Storable Area for Program Data. For the downloaded on-chip program area, see figure 22.10.

One erasure processing erases one block. For details on block divisions, refer to figure 22.4. To erase two or more blocks, update the erase block number and repeat the erasing processing for each block.

1. Select the on-chip program to be downloaded and the download destination. When the PPVS bit in FPCS is set to 1, the programming program is selected. Several programming/erasing programs cannot be selected at one time. If several programs are selected, a download error is returned to the SS bit in the DPFR parameter. The on-chip RAM start address of the download destination is specified by FTDAR.

For the procedures to be carried out after setting FKEY, see section 22.8.2 (2), Programming Procedure in User Program Mode.

2. Set the FEBS parameter necessary for erasure. Set the erase block number (FEBS parameter) of the user MAT in general register ER0. If a value other than an erase block number of the user MAT is set, no block is erased even though the erasing program is executed, and an error is returned to the FPFR parameter.
3. Erasure is executed. Similar to as in programming, the entry point of the erasing program is at the address which is 16 bytes after #DLTOP (start address of the download destination specified by FTDAR). Call the subroutine to execute erasure by using the following steps.

```
MOV.L #DLTOP+16, ER2      ; Set entry address to ER2
JSR  @ER2                ; Call erasing routine
NOP
```

- The general registers other than ER0 and ER1 are held in the erasing program.
 - R0L is a return value of the FPFR parameter.
 - Since the stack area is used in the erasing program, a stack area of 128 bytes at the maximum must be allocated in RAM.
4. The return value in the erasing program, the FPFR parameter is determined.
 5. Determine whether erasure of the necessary blocks has finished. If more than one block is to be erased, update the FEBS parameter and repeat steps 2 to 5.
 6. After erasure completes, clear FKEY and specify software protection. If this LSI is restarted by a power-on reset immediately after erasure has finished, secure the reset input period (period of $\overline{\text{RES}} = 0$) of at least 100 μs .

(4) Procedure of Erasing, Programming, and RAM Emulation in User Program Mode

By changing the on-chip RAM start address of the download destination in FTDAR, the erasing program and programming program can be downloaded to separate on-chip RAM areas.

Figure 22.13 shows a repeating procedure of erasing, programming, and RAM emulation.

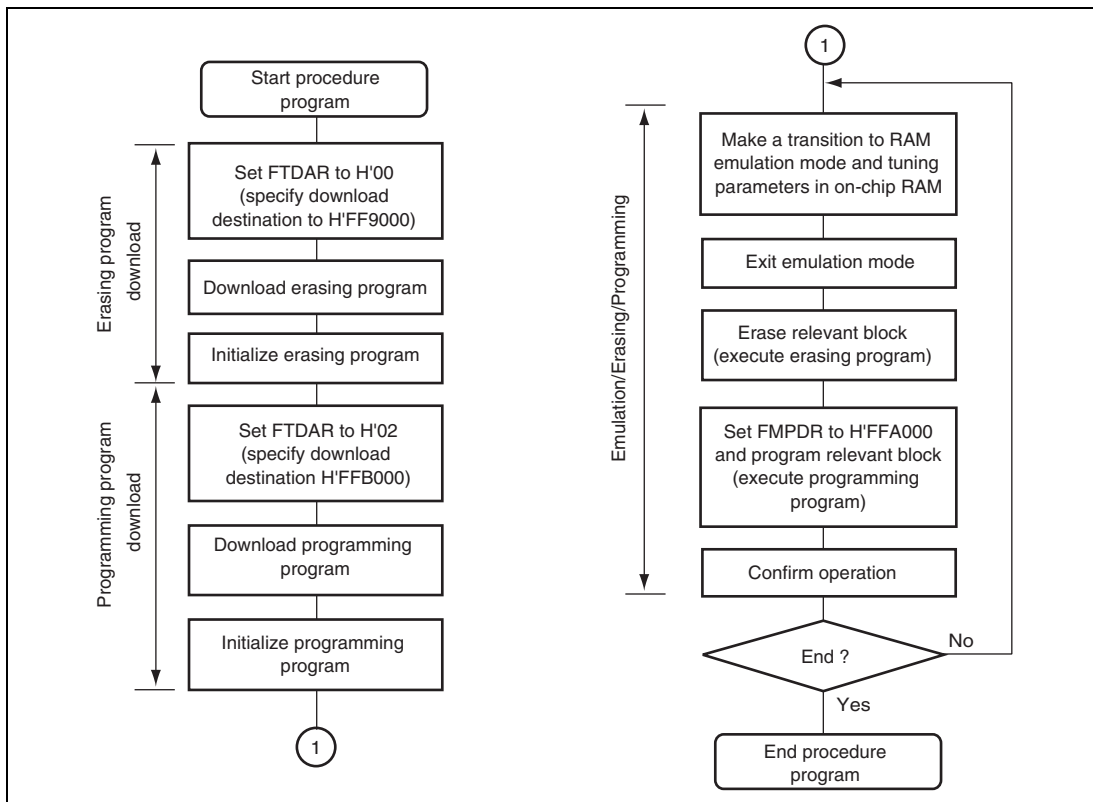

Figure 22.13 Repeating Procedure of Erasing, Programming, and RAM Emulation in User Program Mode

In figure 22.13, since RAM emulation is performed, the erasing/programming program is downloaded to avoid the 4-Kbyte on-chip RAM area (H'FFA000 to H'FFAFFF). Download and initialization are performed only once at the beginning. Note the following when executing the procedure program.

- Be careful not to overwrite data in the on-chip RAM with overlay settings. In addition to the programming program area, erasing program area, and RAM emulation area, areas for the procedure programs, work area, and stack area are reserved in the on-chip RAM. Do not make settings that will overwrite data in these areas.
- Be sure to initialize both the programming program and erasing program. When the FPEFEQ parameter is initialized, also initialize both the erasing program and programming program. Initialization must be executed for both entry addresses: #DLTOP (start address of download destination for erasing program) + 32 bytes, and #DLTOP (start address of download destination for programming program) + 32 bytes.

22.8.3 User Boot Mode

Branching to a programming/erasing program prepared by the user enables user boot mode which is a user-arbitrary boot mode to be used.

Only the user MAT can be programmed/erased in user boot mode. Programming/erasure of the user boot MAT is only enabled in boot mode or programmer mode.

(1) Initiation in User Boot Mode

When the reset start is executed with the mode pins set to user boot mode, the built-in check routine runs and checks the user MAT and user boot MAT states. While the check routine is running, NMI and all other interrupts cannot be accepted. Next, processing starts from the execution start address of the reset vector in the user boot MAT. At this point, the user boot MAT is selected (FMATS = H'AA) as the execution memory MAT.

(2) User MAT Programming in User Boot Mode

Figure 22.14 shows the procedure for programming the user MAT in user boot mode.

The difference between the programming procedures in user program mode and user boot mode is the memory MAT switching as shown in figure 22.14. For programming the user MAT in user boot mode, additional processing made by setting FMATS is required: switching from the user boot MAT to the user MAT, and switching back to the user boot MAT after programming completes.

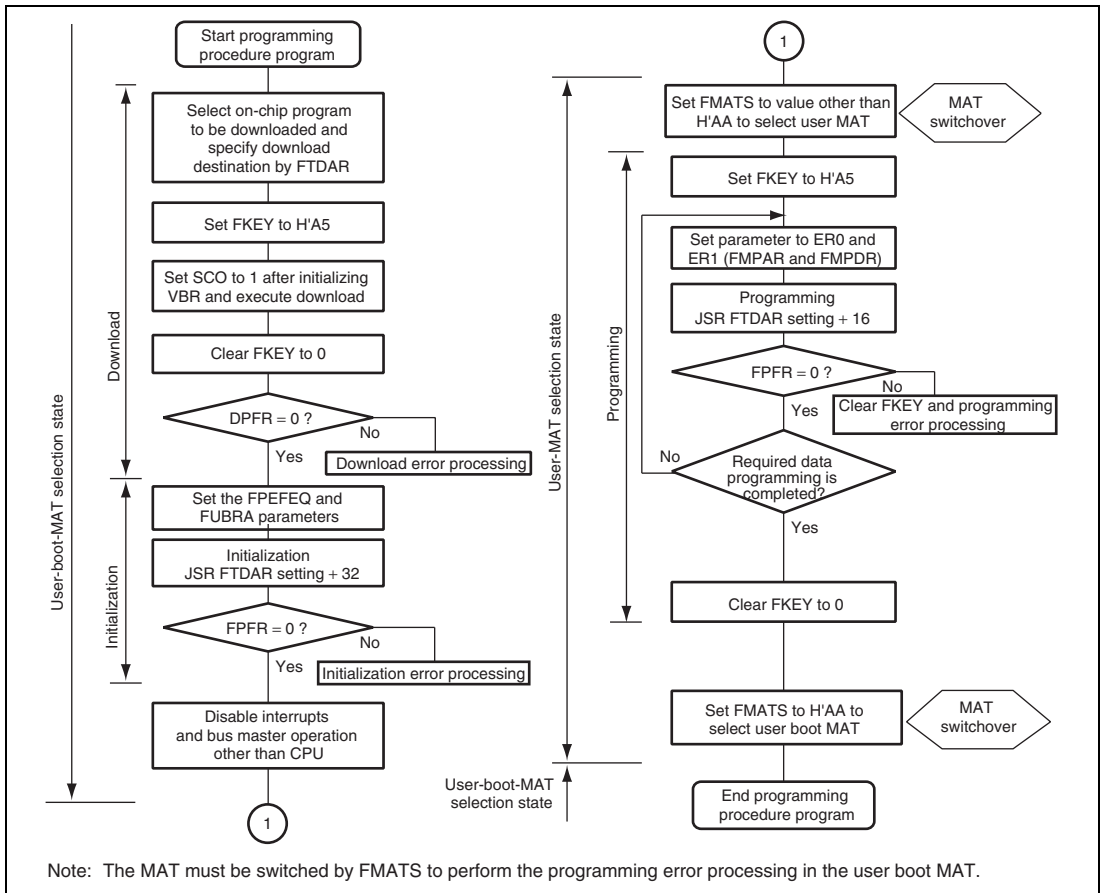

Figure 22.14 Procedure for Programming User MAT in User Boot Mode

In user boot mode, though the user boot MAT can be seen in the flash memory space, the user MAT is hidden in the background. Therefore, the user MAT and user boot MAT are switched while the user MAT is being programmed. Because the user boot MAT is hidden while the user MAT is being programmed, the procedure program must be executed in an area other than flash memory. After programming completes, switch the memory MATs again to return to the first state.

Memory MAT switching is enabled by setting FMATS. However note that access to a memory MAT is not allowed until memory MAT switching is completed. During memory MAT switching, the LSI is in an unstable state, e.g. if an interrupt occurs, from which memory MAT the interrupt vector is read is undetermined. Perform memory MAT switching in accordance with the description in section 22.11, Switching between User MAT and User Boot MAT.

Except for memory MAT switching, the programming procedure is the same as that in user program mode.

The area that can be executed in the steps of the procedure program (on-chip RAM, user MAT, and external space) is shown in section 22.8.4, On-Chip Program and Storable Area for Program Data.

(3) User MAT Erasing in User Boot Mode

Figure 22.15 shows the procedure for erasing the user MAT in user boot mode.

The difference between the erasing procedures in user program mode and user boot mode is the memory MAT switching as shown in figure 22.15. For erasing the user MAT in user boot mode, additional processing made by setting FMATS is required: switching from the user boot MAT to the user MAT, and switching back to the user boot MAT after erasing completes.

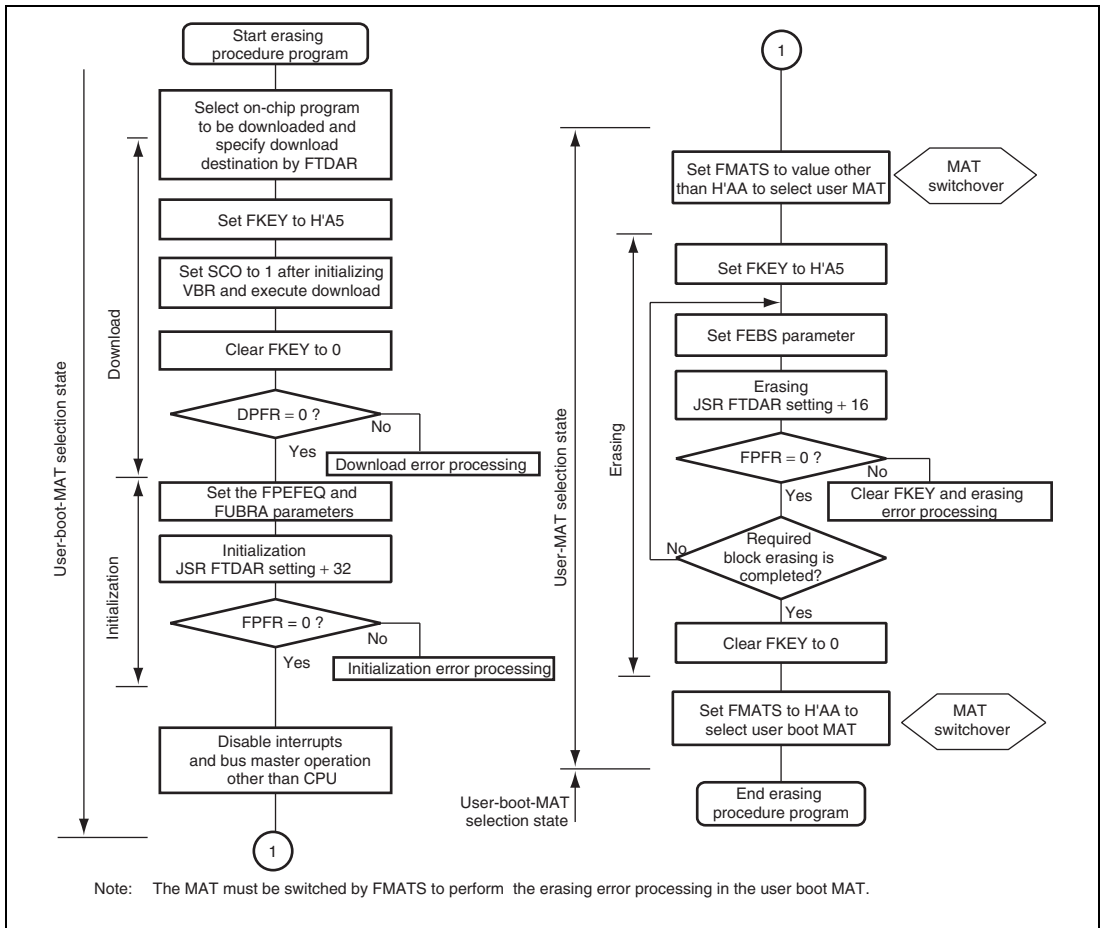

Figure 22.15 Procedure for Erasing User MAT in User Boot Mode

Memory MAT switching is enabled by setting FMATS. However note that access to a memory MAT is not allowed until memory MAT switching is completed. During memory MAT switching, the LSI is in an unstable state, e.g. if an interrupt occurs, from which memory MAT the interrupt vector is read is undetermined. Perform memory MAT switching in accordance with the description in section 22.11, Switching between User MAT and User Boot MAT.

Except for memory MAT switching, the erasing procedure is the same as that in user program mode.

The area that can be executed in the steps of the procedure program (on-chip RAM, user MAT, and external space) is shown in section 22.8.4, On-Chip Program and Storable Area for Program Data.

22.8.4 On-Chip Program and Storable Area for Program Data

In the descriptions in this manual, the on-chip programs and program data storage areas are assumed to be in the on-chip RAM. However, they can be executed from part of the flash memory which is not to be programmed or erased as long as the following conditions are satisfied.

- The on-chip program is downloaded to and executed in the on-chip RAM specified by FTDAR. Therefore, this on-chip RAM area is not available for use.
- Since the on-chip program uses a stack area, allocate 128 bytes at the maximum as a stack area.
- Download requested by setting the SCO bit in FCCS to 1 should be executed from the on-chip RAM because it will require switching of the memory MATs.
- In an operating mode in which the external address space is not accessible, such as single-chip mode, the required procedure programs, NMI handling vector table, and NMI handling routine should be transferred to the on-chip RAM before programming/erasure starts (download result is determined).
- The flash memory is not accessible during programming/erasure. Programming/erasure is executed by the program downloaded to the on-chip RAM. Therefore, the procedure program that initiates operation, the NMI handling vector table, and the NMI handling routine should be stored in the on-chip RAM other than the flash memory.
- After programming/erasure starts, access to the flash memory should be inhibited until FKEY is cleared. The reset input state (period of $\overline{\text{RES}} = 0$) must be set to at least 100 μs when the operating mode is changed and the reset start executed on completion of programming/erasure. Transitions to the reset state are inhibited during programming/erasure. When the reset signal is input, a reset input state (period of $\overline{\text{RES}} = 0$) of at least 100 μs is needed before the reset signal is released.

- Switching of the memory MATs by FMATS should be needed when programming/erasure of the user MAT is operated in user boot mode. The program which switches the memory MATs should be executed from the on-chip RAM. For details, see section 22.11, Switching between User MAT and User Boot MAT. Make sure you know which memory MAT is currently selected when switching them.
- When the program data storage area is within the flash memory area, an error will occur even when the data stored is normal program data. Therefore, the data should be transferred to the on-chip RAM to place the address that the FMPDR parameter indicates in an area other than the flash memory.

In consideration of these conditions, the areas in which the program data can be stored and executed are determined by the combination of the processing contents, operating mode, and bank structure of the memory MATs, as shown in tables 22.7 to 22.11.

Table 22.7 Executable Memory MAT

Processing Contents	Operating Mode	
	User Program Mode	User Boot Mode*
Programming	See table 22.8	See table 22.10
Erasing	See table 22.9	See table 22.11

Note: * Programming/Erasure is possible to the user MAT.

Table 22.8 Usable Area for Programming in User Program Mode

Item	Storable/Executable Area		Selected MAT	
	On-Chip RAM	User MAT	User MAT	Embedded Program Storage MAT
Storage area for program data	○	×*	—	—
Operation for selecting on-chip program to be downloaded	○	○	○	
Operation for writing H'A5 to FKEY	○	○	○	
Execution of writing 1 to SCO bit in FCCS (download)	○	×		○
Operation for clearing FKEY	○	○	○	
Decision of download result	○	○	○	
Operation for download error	○	○	○	
Operation for setting initialization parameter	○	○	○	
Execution of initialization	○	×	○	
Decision of initialization result	○	○	○	
Operation for initialization error	○	○	○	
NMI handling routine	○	×	○	
Operation for disabling interrupts	○	○	○	
Operation for writing H'5A to FKEY	○	○	○	
Operation for setting programming parameter	○	×	○	
Execution of programming	○	×	○	
Decision of programming result	○	×	○	
Operation for programming error	○	×	○	
Operation for clearing FKEY	○	×	○	

Note: * Transferring the program data to the on-chip RAM beforehand enables this area to be used.

Table 22.9 Usable Area for Erasure in User Program Mode

Item	Storable/Executable Area		Selected MAT	
	On-Chip RAM	User MAT	User MAT	Embedded Program Storage MAT
Operation for selecting on-chip program to be downloaded	○	○	○	
Operation for writing H'A5 to FKEY	○	○	○	
Execution of writing 1 to SCO bit in FCCS (download)	○	×		○
Operation for clearing FKEY	○	○	○	
Decision of download result	○	○	○	
Operation for download error	○	○	○	
Operation for setting initialization parameter	○	○	○	
Execution of initialization	○	×	○	
Decision of initialization result	○	○	○	
Operation for initialization error	○	○	○	
NMI handling routine	○	×	○	
Operation for disabling interrupts	○	○	○	
Operation for writing H'5A to FKEY	○	○	○	
Operation for setting erasure parameter	○	×	○	
Execution of erasure	○	×	○	
Decision of erasure result	○	×	○	
Operation for erasure error	○	×	○	
Operation for clearing FKEY	○	×	○	

Table 22.10 Usable Area for Programming in User Boot Mode

Item	Storable/Executable Area			Selected MAT	
	On-Chip RAM	User Boot MAT	User MAT	User Boot MAT	Embedded Program Storage MAT
Storage area for program data	○	×* ¹	—	—	—
Operation for selecting on-chip program to be downloaded	○	○		○	
Operation for writing H'A5 to FKEY	○	○		○	
Execution of writing 1 to SCO bit in FCCS (download)	○	×			○
Operation for clearing FKEY	○	○		○	
Decision of download result	○	○		○	
Operation for download error	○	○		○	
Operation for setting initialization parameter	○	○		○	
Execution of initialization	○	×		○	
Decision of initialization result	○	○		○	
Operation for initialization error	○	○		○	
NMI handling routine	○	×		○	
Operation for disabling interrupts	○	○		○	
Switching memory MATs by FMATS	○	×	○		
Operation for writing H'5A to FKEY	○	×	○		
Operation for setting programming parameter	○	×	○		
Execution of programming	○	×	○		
Decision of programming result	○	×	○		
Operation for programming error	○	×* ²	○		
Operation for clearing FKEY	○	×	○		
Switching memory MATs by FMATS	○	×		○	

Notes: 1. Transferring the program data to the on-chip RAM beforehand enables this area to be used.

2. Switching memory MATs by FMATS by a program in the on-chip RAM enables this area to be used.

Table 22.11 Usable Area for Erasure in User Boot Mode

Item	Storable/Executable Area			Selected MAT	
	On-Chip RAM	User Boot MAT	User MAT	User Boot MAT	Embedded Program Storage MAT
Operation for selecting on-chip program to be downloaded	○	○		○	
Operation for writing H'A5 to FKEY	○	○		○	
Execution of writing 1 to SCO bit in FCCS (download)	○	×			○
Operation for clearing FKEY	○	○		○	
Decision of download result	○	○		○	
Operation for download error	○	○		○	
Operation for setting initialization parameter	○	○		○	
Execution of initialization	○	×		○	
Decision of initialization result	○	○		○	
Operation for initialization error	○	○		○	
NMI handling routine	○	×		○	
Operation for disabling interrupts	○	○		○	
Switching memory MATs by FMATS	○	×	○		
Operation for writing H'5A to FKEY	○	×	○		
Operation for setting erasure parameter	○	×	○		
Execution of erasure	○	×	○		
Decision of erasure result	○	×	○		
Operation for erasure error	○	×*	○		
Operation for clearing FKEY	○	×	○		
Switching memory MATs by FMATS	○	×	○		

Note: * Switching memory MATs by FMATS by a program in the on-chip RAM enables this area to be used.

22.9 Protection

There are three types of protection against the flash memory programming/erasure: hardware protection, software protection, and error protection.

22.9.1 Hardware Protection

Programming and erasure of the flash memory is forcibly disabled or suspended by hardware protection. In this state, download of an on-chip program and initialization are possible. However, programming or erasure of the user MAT cannot be performed even if the programming/erasing program is initiated, and the error in programming/erasure is indicated by the FPFR parameter.

Table 22.12 Hardware Protection

Item	Description	Function to be Protected	
		Download	Programming/ Erasing
Reset protection	<ul style="list-style-type: none"> The programming/erasing interface registers are initialized in the reset state (including a reset by the WDT) and the programming/erasing protection state is entered. The reset state will not be entered by a reset using the $\overline{\text{RES}}$ pin unless the $\overline{\text{RES}}$ pin is held low until oscillation has settled after a power is initially supplied. In the case of a reset during operation, hold the $\overline{\text{RES}}$ pin low for the $\overline{\text{RES}}$ pulse width given in the AC characteristics. If a reset is input during programming or erasure, data in the flash memory is not guaranteed. In this case, execute erasure and then execute programming again. 	O	O

22.9.2 Software Protection

The software protection protects the flash memory against programming/erasure by disabling download of the programming/erasing program, using the key code, and by the RAMER setting.

Table 22.13 Software Protection

Item	Description	Function to be Protected	
		Download	Programming/ Erasing
Protection by SCO bit	The programming/erasing protection state is entered when the SCO bit in FCCS is cleared to 0 to disable download of the programming/erasing programs.	○	○
Protection by FKEY	The programming/erasing protection state is entered because download and programming/erasure are disabled unless the required key code is written in FKEY.	○	○
Emulation protection	The programming/erasing protection state is entered when the RAMS bit in the RAM emulation register (RAMER) is set to 1.	○	○

22.9.3 Error Protection

Error protection is a mechanism for aborting programming or erasure when a CPU runaway occurs or operations not according to the programming/erasing procedures are detected during programming/erasure of the flash memory. Aborting programming or erasure in such cases prevents damage to the flash memory due to excessive programming or erasing.

If an error occurs during programming/erasure of the flash memory, the FLER bit in FCCS is set to 1 and the error protection state is entered.

- When an interrupt request, such as NMI, occurs during programming/erasure.
- When the flash memory is read from during programming/erasure (including a vector read or an instruction fetch).
- When a SLEEP instruction is executed (including software-standby mode) during programming/erasure.
- When a bus master other than the CPU, such as the DMAC and DTC, obtains bus mastership during programming/erasure.

Error protection is canceled by a reset. Note that the reset should be released after the reset input period of at least 100 μ s has passed. Since high voltages are applied during programming/erasure of the flash memory, some voltage may remain after the error protection state has been entered. For this reason, it is necessary to reduce the risk of damaging the flash memory by extending the reset input period so that the charge is released.

The state-transition diagram in figure 22.16 shows transitions to and from the error protection state.

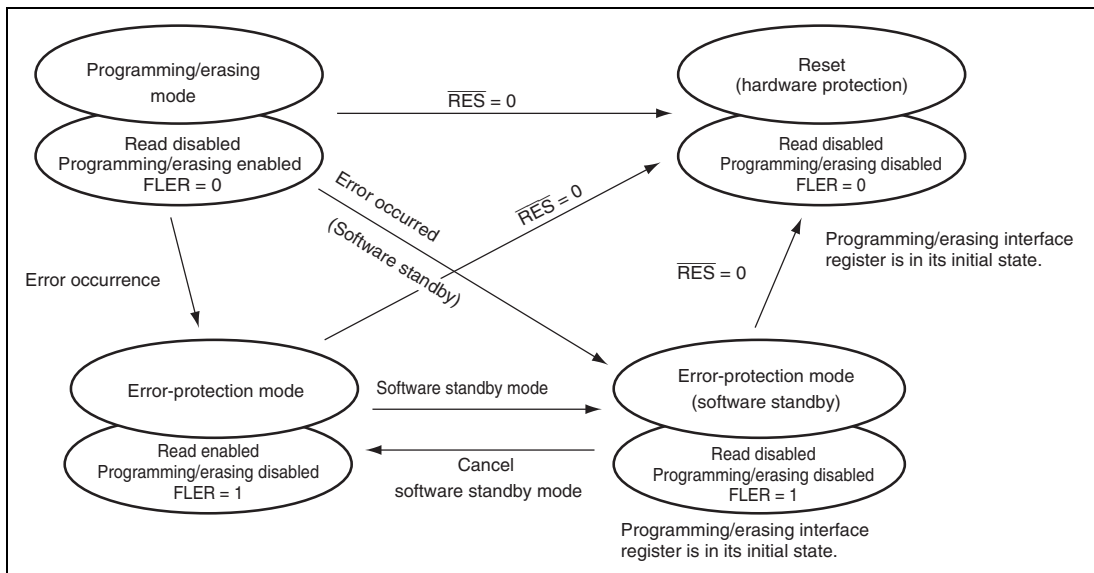

Figure 22.16 Transitions to Error Protection State

22.10 Flash Memory Emulation Using RAM

For realtime emulation of the data written to the flash memory using the on-chip RAM, the on-chip RAM area can be overlaid with several flash memory blocks (user MAT) using the RAM emulation register (RAMER).

The overlaid area can be accessed from both the user MAT area specified by RAMER and the overlaid RAM area. The emulation can be performed in user mode and user program mode.

Figure 22.17 shows an example of emulating realtime programming of the user MAT.

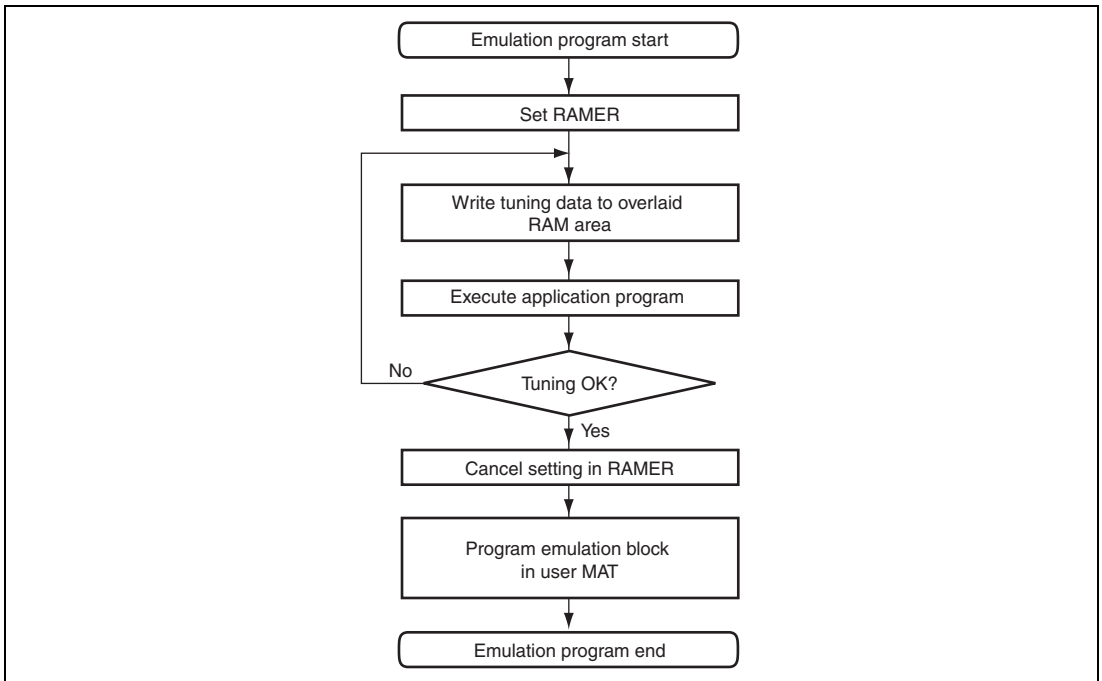

Figure 22.17 RAM Emulation Flow

Figure 22.18 shows an example of overlaying flash memory block area EB0.

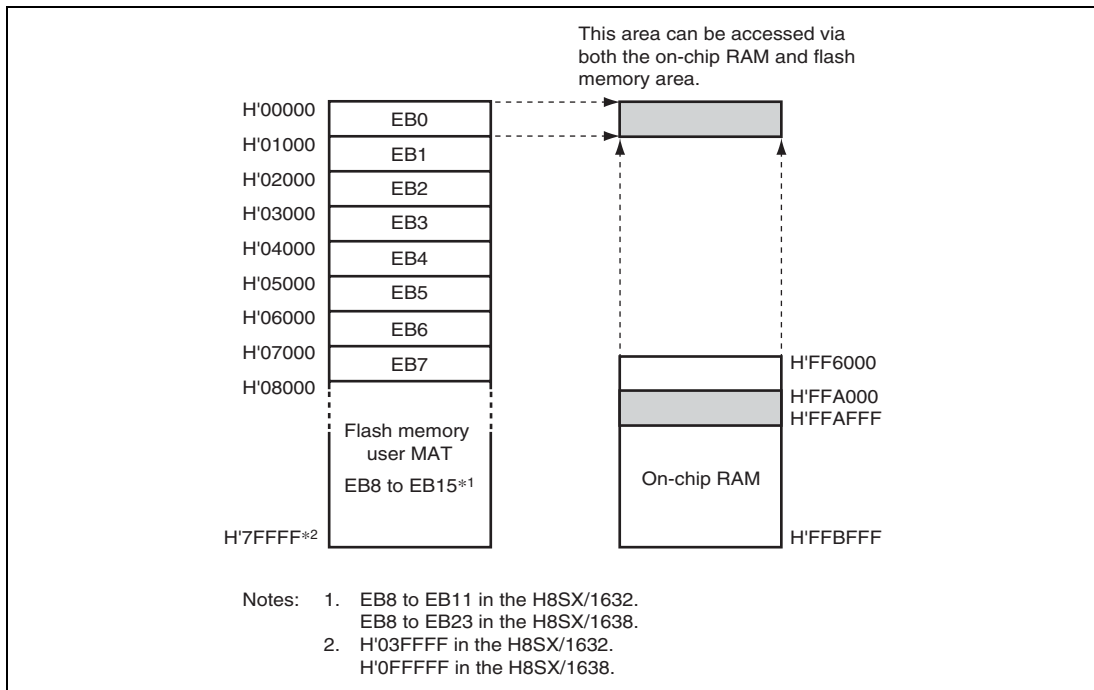

Figure 22.18 Address Map of Overlaid RAM Area (H8SX/1634)

The flash memory area that can be emulated is the one area selected by bits RAM2 to RAM0 in RAMER from among the eight blocks, EB0 to EB7, of the user MAT.

To overlay a part of the on-chip RAM with block EB0 for realtime emulation, set the RAMS bit in RAMER to 1 and bits RAM2 to RAM0 to B'000.

For programming/erasing the user MAT, the procedure programs including a download program of the on-chip program must be executed. At this time, the download area should be specified so that the overlaid RAM area is not overwritten by downloading the on-chip program. Since the area in which the tuned data is stored is overlaid with the download area when FTDAR = H'01, the tuned data must be saved in an unused area beforehand.

Figure 22.19 shows an example of the procedure to program the tuned data in block EB0 of the user MAT.

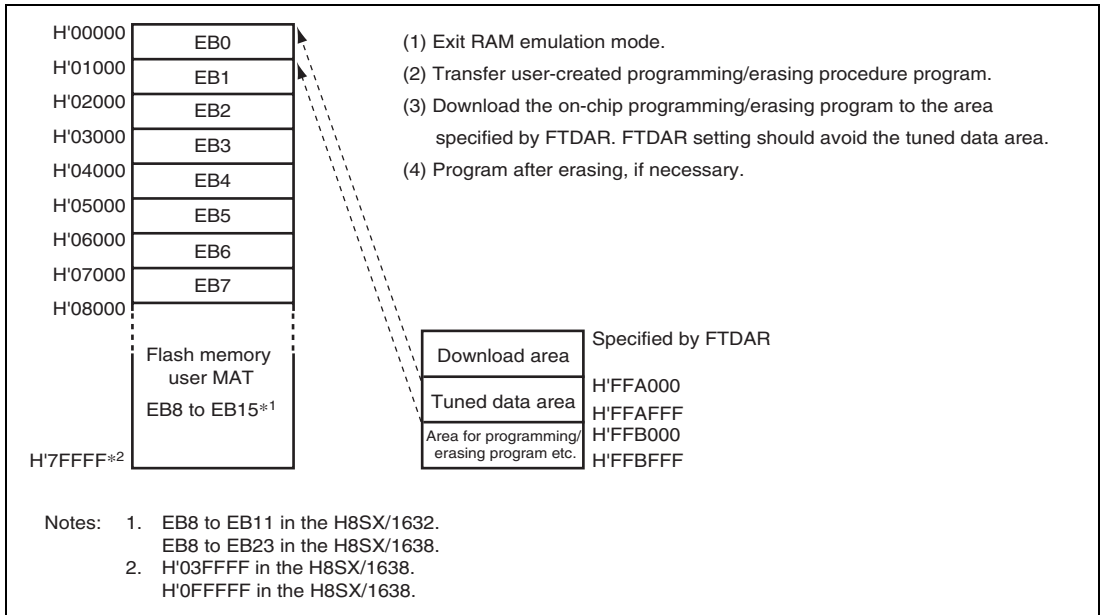

Figure 22.19 Programming Tuned Data (H8SX/1634)

1. After tuning program data is completed, clear the RAMS bit in RAMER to 0 to cancel the overlaid RAM.
2. Transfer the user-created procedure program to the on-chip RAM.
3. Start the procedure program and download the on-chip program to the on-chip RAM. The start address of the download destination should be specified by FTDAR so that the tuned data area does not overlay the download area.
4. When block EB0 of the user MAT has not been erased, the programming program must be downloaded after block EB0 is erased. Specify the tuned data saved in the FMPAR and FMPDR parameters and then execute programming.

Note: Setting the RAMS bit to 1 makes all the blocks of the user MAT enter the programming/erasing protection state (emulation protection state) regardless of the setting of the RAM2 to RAM0 bits. Under this condition, the on-chip program cannot be downloaded. When data is to be actually programmed and erased, clear the RAMS bit to 0.

22.11 Switching between User MAT and User Boot MAT

It is possible to switch between the user MAT and user boot MAT. However, the following procedure is required because the start addresses of these MATs are allocated to the same address.

Switching to the user boot MAT disables programming and erasing. Programming of the user boot MAT should take place in boot mode or programmer mode.

1. Memory MAT switching by FMATS should always be executed from the on-chip RAM.
2. When accessing the memory MAT immediately after switching the memory MATs by FMATS from the on-chip RAM, similarly execute the NOP instruction in the on-chip RAM for eight times (this prevents access to the flash memory during memory MAT switching).
3. If an interrupt request has occurred during memory MAT switching, there is no guarantee of which memory MAT is accessed. Always mask the maskable interrupts before switching memory MATs. In addition, configure the system so that NMI interrupts do not occur during memory MAT switching.
4. After the memory MATs have been switched, take care because the interrupt vector table will also have been switched. If interrupt processing is to be the same before and after memory MAT switching, transfer the interrupt processing routines to the on-chip RAM and specify VBR to place the interrupt vector table in the on-chip RAM.
5. The size of the user MAT is different from that of the user boot MAT. Addresses which exceed the size of the 16-Kbyte user boot MAT should not be accessed. If an attempt is made, data is read as an undefined value.

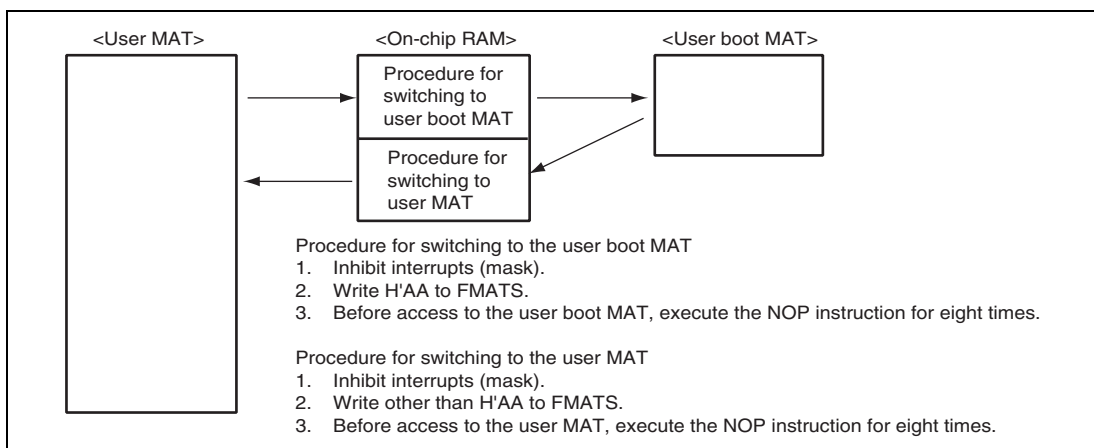

Figure 22.20 Switching between User MAT and User Boot MAT

22.12 Programmer Mode

Along with its on-board programming mode, this LSI also has a programmer mode as a further mode for the writing and erasing of programs and data. In programmer mode, a general-purpose PROM programmer that supports the device types shown in table 22.14 can be used to write programs to the on-chip ROM without any limitation.

Table 22.14 Device Types Supported in Programmer Mode

Target Memory MAT	Product Classification	ROM Size	Device Type
User MAT	H8SX/1632	256 Kbytes	FZTAT256V3A
	H8SX/1634	512 Kbytes	FZTAT512V3A
	H8SX/1638	1 Mbyte	FZTAT1024V3A
User boot MAT	H8SX/1632	16 Kbytes	FZTATUSBT16V3A
	H8SX/1634		
	H8SX/1638		

22.13 Standard Serial Communication Interface Specifications for Boot Mode

The boot program initiated in boot mode performs serial communication using the host and on-chip SCI_4. The serial communication interface specifications are shown below.

The boot program has three states.

1. Bit-rate-adjustment state

In this state, the boot program adjusts the bit rate to achieve serial communication with the host. Initiating boot mode enables starting of the boot program and entry to the bit-rate-adjustment state. The program receives the command from the host to adjust the bit rate. After adjusting the bit rate, the program enters the inquiry/selection state.

2. Inquiry/selection state

In this state, the boot program responds to inquiry commands from the host. The device name, clock mode, and bit rate are selected. After selection of these settings, the program is made to enter the programming/erasing state by the command for a transition to the programming/erasing state. The program transfers the libraries required for erasure to the on-chip RAM and erases the user MATs and user boot MATs before the transition.

3. Programming/erasing state

Programming and erasure by the boot program take place in this state. The boot program is made to transfer the programming/erasing programs to the on-chip RAM by commands from the host. Sum checks and blank checks are executed by sending these commands from the host.

These boot program states are shown in figure 22.21.

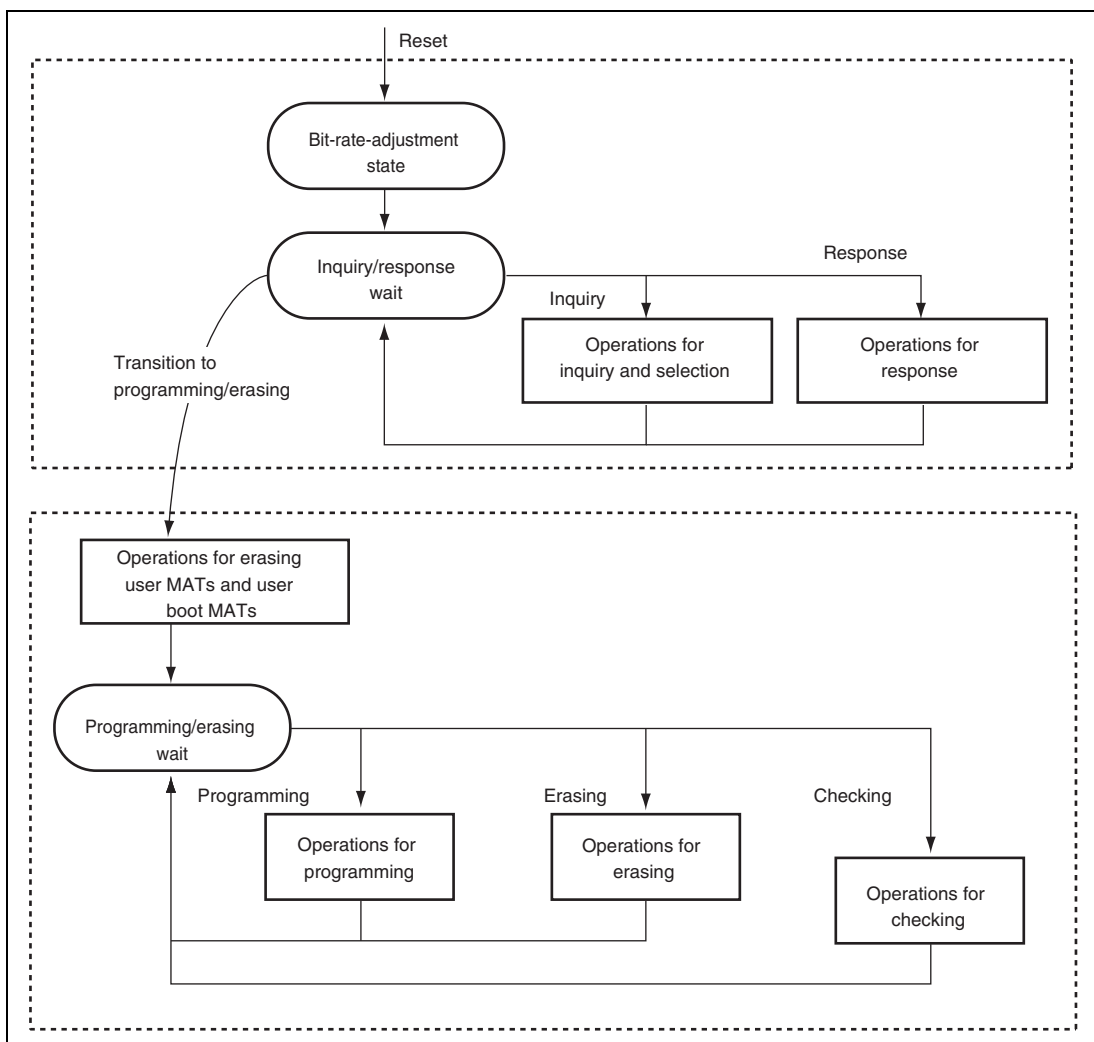

Figure 22.21 Boot Program States

(1) Bit-Rate-Adjustment State

The bit rate is calculated by measuring the period of transfer of a low-level byte (H'00) from the host. The bit rate can be changed by the command for a new bit rate selection. After the bit rate has been adjusted, the boot program enters the inquiry and selection state. The bit-rate-adjustment sequence is shown in figure 22.22.

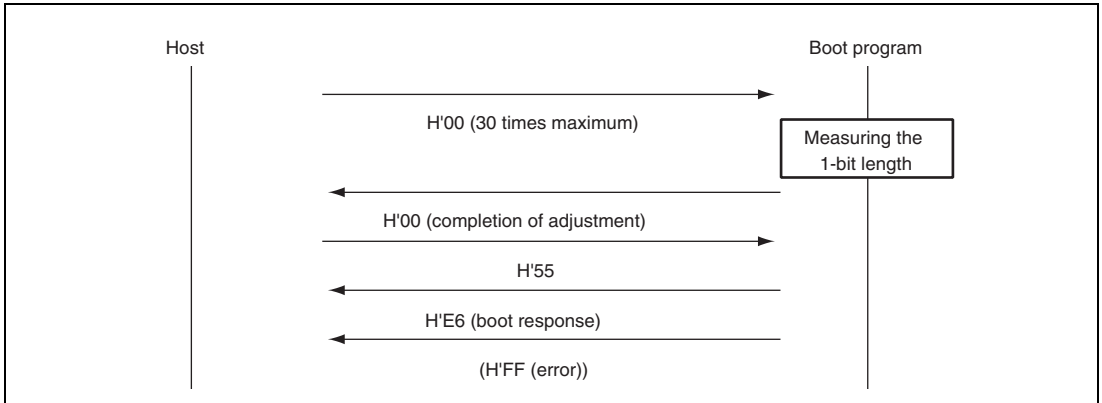

Figure 22.22 Bit-Rate-Adjustment Sequence

(2) Communications Protocol

After adjustment of the bit rate, the protocol for serial communications between the host and the boot program is as shown below.

1. One-byte commands and one-byte responses

These one-byte commands and one-byte responses consist of the inquiries and the ACK for successful completion.

2. n-byte commands or n-byte responses

These commands and responses are comprised of n bytes of data. These are selections and responses to inquiries.

The program data size is not included under this heading because it is determined in another command.

3. Error response

The error response is a response to inquiries. It consists of an error response and an error code and comes two bytes.

4. Programming of 128 bytes

The size is not specified in commands. The size of n is indicated in response to the programming unit inquiry.

5. Memory read response

This response consists of four bytes of data.

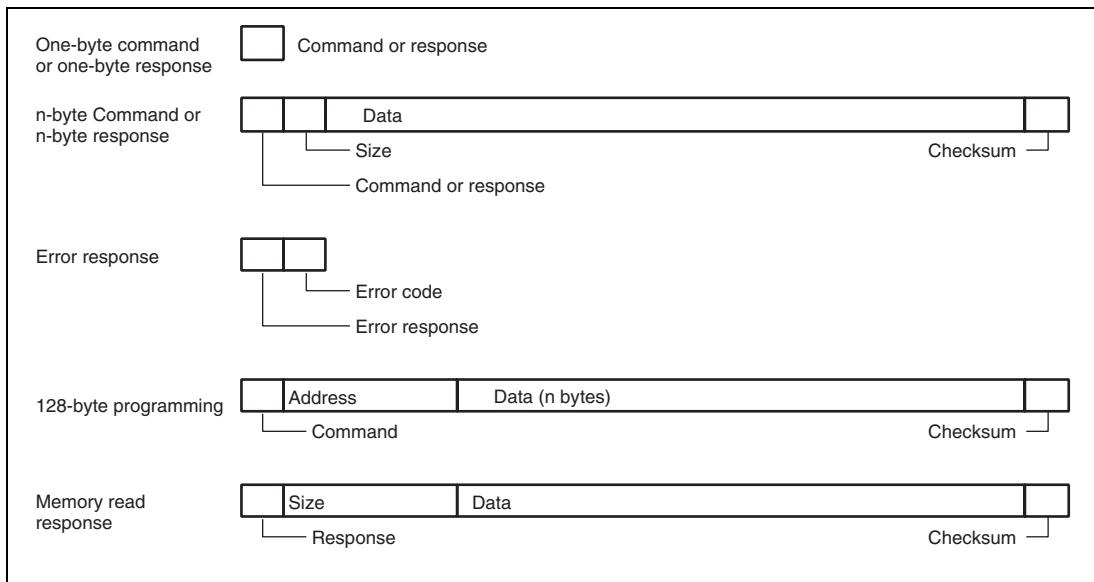

Figure 22.23 Communication Protocol Format

- **Command (one byte):** Commands including inquiries, selection, programming, erasing, and checking
- **Response (one byte):** Response to an inquiry
- **Size (one byte):** The amount of data for transmission excluding the command, amount of data, and checksum
- **Checksum (one byte):** The checksum is calculated so that the total of all values from the command byte to the SUM byte becomes H'00.
- **Data (n bytes):** Detailed data of a command or response
- **Error response (one byte):** Error response to a command
- **Error code (one byte):** Type of the error
- **Address (four bytes):** Address for programming
- **Data (n bytes):** Data to be programmed (the size is indicated in the response to the programming unit inquiry.)
- **Size (four bytes):** Four-byte response to a memory read

(3) Inquiry and Selection States

The boot program returns information from the flash memory in response to the host's inquiry commands and sets the device code, clock mode, and bit rate in response to the host's selection command.

Table 22.15 lists the inquiry and selection commands.

Table 22.15 Inquiry and Selection Commands

Command	Command Name	Description
H'20	Supported device inquiry	Inquiry regarding device codes
H'10	Device selection	Selection of device code
H'21	Clock mode inquiry	Inquiry regarding numbers of clock modes and values of each mode
H'11	Clock mode selection	Indication of the selected clock mode
H'22	Multiplication ratio inquiry	Inquiry regarding the number of frequency-multiplied clock types, the number of multiplication ratios, and the values of each multiple
H'23	Operating clock frequency inquiry	Inquiry regarding the maximum and minimum values of the main clock and peripheral clocks
H'24	User boot MAT information inquiry	Inquiry regarding the number of user boot MATs and the start and last addresses of each MAT
H'25	User MAT information inquiry	Inquiry regarding the a number of user MATs and the start and last addresses of each MAT
H'26	Block for erasing information Inquiry	Inquiry regarding the number of blocks and the start and last addresses of each block
H'27	Programming unit inquiry	Inquiry regarding the unit of program data
H'3F	New bit rate selection	Selection of new bit rate
H'40	Transition to programming/erasing state	Erasing of user MAT and user boot MAT, and entry to programming/erasing state
H'4F	Boot program status inquiry	Inquiry into the operated status of the boot program

The selection commands, which are device selection (H'10), clock mode selection (H'11), and new bit rate selection (H'3F), should be sent from the host in that order. When two or more selection commands are sent at once, the last command will be valid.

All of these commands, except for the boot program status inquiry command (H'4F), will be valid until the boot program receives the programming/erasing transition (H'40). The host can choose the needed commands and make inquiries while the above commands are being transmitted. H'4F is valid even after the boot program has received H'40.

(a) Supported Device Inquiry

The boot program will return the device codes of supported devices and the product code in response to the supported device inquiry.

Command

H'20

- Command, H'20, (one byte): Inquiry regarding supported devices

Response	H'30	Size	Number of devices	
	Number of characters	Device code		Product name
	...			
	SUM			

- Response, H'30, (one byte): Response to the supported device inquiry
- Size (one byte): Number of bytes to be transmitted, excluding the command, size, and checksum, that is, the amount of data contributes by the number of devices, characters, device codes and product names
- Number of devices (one byte): The number of device types supported by the boot program
- Number of characters (one byte): The number of characters in the device codes and boot program's name
- Device code (four bytes): ASCII code of the supporting product
- Product name (n bytes): Type name of the boot program in ASCII-coded characters
- SUM (one byte): Checksum

The checksum is calculated so that the total number of all values from the command byte to the SUM byte becomes H'00.

(b) Device Selection

The boot program will set the supported device to the specified device code. The program will return the selected device code in response to the inquiry after this setting has been made.

Command	H'10	Size	Device code	SUM
---------	------	------	-------------	-----

- Command, H'10, (one byte): Device selection
- Size (one byte): Amount of device-code data
This is fixed at 4.
- Device code (four bytes): Device code (ASCII code) returned in response to the supported device inquiry
- SUM (one byte): Checksum

Response	H'06
----------	------

- Response, H'06, (one byte): Response to the device selection command
ACK will be returned when the device code matches.

Error response	H'90	ERROR
----------------	------	-------

- Error response, H'90, (one byte): Error response to the device selection command
ERROR : (one byte): Error code
H'11: Sum check error
H'21: Device code error, that is, the device code does not match

(c) Clock Mode Inquiry

The boot program will return the supported clock modes in response to the clock mode inquiry.

Command	H'21
---------	------

- Command, H'21, (one byte): Inquiry regarding clock mode

Response	H'31	Size	Mode	...	SUM
----------	------	------	------	-----	-----

- Response, H'31, (one byte): Response to the clock-mode inquiry
- Size (one byte): Amount of data that represents the modes
- Mode (one byte): Values of the supported clock modes (i.e. H'01 means clock mode 1.)
- SUM (one byte): Checksum

(d) Clock Mode Selection

The boot program will set the specified clock mode. The program will return the selected clock-mode information after this setting has been made.

The clock-mode selection command should be sent after the device-selection commands.

Command

H'11	Size	Mode	SUM
------	------	------	-----

- Command, H'11, (one byte): Selection of clock mode
- Size (one byte): Amount of data that represents the modes
- Mode (one byte): A clock mode returned in reply to the supported clock mode inquiry.
- SUM (one byte): Checksum

Response

H'06

- Response, H'06, (one byte): Response to the clock mode selection command
ACK will be returned when the clock mode matches.

Error Response

H'91	ERROR
------	-------

- Error response, H'91, (one byte): Error response to the clock mode selection command
- ERROR : (one byte): Error code
H'11: Checksum error
H'22: Clock mode error, that is, the clock mode does not match.

Even if the clock mode numbers are H'00 and H'01 by a clock mode inquiry, the clock mode must be selected using these respective values.

(e) Multiplication Ratio Inquiry

The boot program will return the supported multiplication and division ratios.

Command

H'22

- Command, H'22, (one byte): Inquiry regarding multiplication ratio

Response	H'32	Size	Number of types of multiplication					
	Number of multiplication ratios	Multiplication ratio	...					
	...							
	SUM							

- Response, H'32, (one byte): Response to the multiplication ratio inquiry
- Size (one byte): The amount of data that represents the numbers of types of multiplication, the number of multiplication ratios, and the multiplication ratios
- Number of types of multiplication (one byte): The number of types of multiplication ratios to which the device can be set.
(e.g. when there are two multiplied clock types, which are the main and peripheral clocks, the number of types will be H'02.)
- Number of multiplication ratios (one byte): The number of multiplication ratios for each type (e.g. the number of multiplication ratios to which the main clock can be set and the peripheral clock can be set.)
- Multiplication ratio (one byte)
 Multiplication ratio: The value of the multiplication ratio (e.g. when the clock-frequency multiplier is four, the value of multiplication ratio will be H'04.)
 Division ratio: The inverse of the division ratio, i.e. a negative number (e.g. when the clock is divided by two, the value of division ratio will be H'FE. $H'FE = D'-2$)
 The number of multiplication ratios returned is the same as the number of multiplication ratios and as many groups of data are returned as there are types of multiplication.
- SUM (one byte): Checksum

(f) Operating Clock Frequency Inquiry

The boot program will return the number of operating clock frequencies, and the maximum and minimum values.

Command

H'23

- Command, H'23, (one byte): Inquiry regarding operating clock frequencies

Response	H'33	Size	Number of operating clock frequencies
	Minimum value of operating clock frequency		Maximum value of operating clock frequency
	...		
	SUM		

- Response, H'33, (one byte): Response to operating clock frequency inquiry
- Size (one byte): The number of bytes that represents the minimum values, maximum values, and the number of frequencies.
- Number of operating clock frequencies (one byte): The number of supported operating clock frequency types
(e.g. when there are two operating clock frequency types, which are the main and peripheral clocks, the number of types will be H'02.)
- Minimum value of operating clock frequency (two bytes): The minimum value of the multiplied or divided clock frequency.

The minimum and maximum values of the operating clock frequency represent the values in MHz, valid to the hundredths place of MHz, and multiplied by 100. (e.g. when the value is 17.00 MHz, it will be 2000, which is H'07D0.)

- Maximum value (two bytes): Maximum value among the multiplied or divided clock frequencies.
There are as many pairs of minimum and maximum values as there are operating clock frequencies.
- SUM (one byte): Checksum

(g) User Boot MAT Information Inquiry

The boot program will return the number of user boot MATs and their addresses.

Command

H'24

- Command, H'24, (one byte): Inquiry regarding user boot MAT information

Response	H'34	Size	Number of areas	
	Area-start address			Area-last address
	...			
	SUM			

- Response, H'34, (one byte): Response to user boot MAT information inquiry
- Size (one byte): The number of bytes that represents the number of areas, area-start addresses, and area-last address
- Number of Areas (one byte): The number of consecutive user boot MAT areas
When user boot MAT areas are consecutive, the number of areas returned is H'01.
- Area-start address (four byte): Start address of the area
- Area-last address (four byte): Last address of the area
There are as many groups of data representing the start and last addresses as there are areas.
- SUM (one byte): Checksum

(h) User MAT Information Inquiry

The boot program will return the number of user MATs and their addresses.

Command

H'25

- Command, H'25, (one byte): Inquiry regarding user MAT information

Response	H'35	Size	Number of areas	
	Start address area			Last address area
	...			
	SUM			

- Response, H'35, (one byte): Response to the user MAT information inquiry
- Size (one byte): The number of bytes that represents the number of areas, area-start address and area-last address
- Number of areas (one byte): The number of consecutive user MAT areas
When the user MAT areas are consecutive, the number of areas is H'01.
- Area-start address (four bytes): Start address of the area

- Area-last address (four bytes): Last address of the area
There are as many groups of data representing the start and last addresses as there are areas.
- SUM (one byte): Checksum

(i) Erased Block Information Inquiry

The boot program will return the number of erased blocks and their addresses.

Command

H'26

- Command, H'26, (two bytes): Inquiry regarding erased block information

Response	H'36	Size	Number of blocks	
	Block start address			Block last address
	...			
	SUM			

- Response, H'36, (one byte): Response to the number of erased blocks and addresses
- Size (three bytes): The number of bytes that represents the number of blocks, block-start addresses, and block-last addresses.
- Number of blocks (one byte): The number of erased blocks
- Block start address (four bytes): Start address of a block
- Block last Address (four bytes): Last address of a block
There are as many groups of data representing the start and last addresses as there are areas.
- SUM (one byte): Checksum

(j) Programming Unit Inquiry

The boot program will return the programming unit used to program data.

Command

H'27

- Command, H'27, (one byte): Inquiry regarding programming unit

Response	H'37	Size	Programming unit	SUM
----------	------	------	------------------	-----

- Response, H'37, (one byte): Response to programming unit inquiry
- Size (one byte): The number of bytes that indicate the programming unit, which is fixed to 2
- Programming unit (two bytes): A unit for programming
This is the unit for reception of programming.
- SUM (one byte): Checksum

(k) New Bit-Rate Selection

The boot program will set a new bit rate and return the new bit rate.

This selection should be sent after sending the clock mode selection command.

Command	H'3F	Size	Bit rate	Input frequency
	Number of types of multiplication	Multiplication ratio 1	Multiplication ratio 2	
	SUM			

- Command, H'3F, (one byte): Selection of new bit rate
- Size (one byte): The number of bytes that represents the bit rate, input frequency, number of types of multiplication ratios, and multiplication ratio
- Bit rate (two bytes): New bit rate
One hundredth of the value (e.g. when the value is 19200 bps, it will be 192, which is H'00C0.)
- Input frequency (two bytes): Frequency of the clock input to the boot program
This is valid to the hundredths place and represents the value in MHz multiplied by 100. (E.g. when the value is 20.00 MHz, it will be 2000, which is H'07D0.)
- Number of types of multiplication ratios (one byte): The number of types of multiplication ratios to which the device can be set.
(e.g. when there are two multiplied clock types, which are the main and peripheral clocks, the number of types will be H'02.)
- Multiplication ratio 1 (one byte): The value of multiplication or division ratios for the main operating frequency
Multiplication ratio (one byte): The value of the multiplication ratio (e.g. when the clock frequency is multiplied by four, the multiplication ratio will be H'04.)
Division ratio: The inverse of the division ratio, as a negative number (e.g. when the clock frequency is divided by two, the value of division ratio will be H'FE. $H'FE = D^{-2}$)
- Multiplication ratio 2 (one byte): The value of multiplication or division ratios for the peripheral frequency
Multiplication ratio (one byte): The value of the multiplication ratio (e.g. when the clock frequency is multiplied by four, the multiplication ratio will be H'04.)
(Division ratio: The inverse of the division ratio, as a negative number (E.g. when the clock is divided by two, the value of division ratio will be H'FE. $H'FE = D^{-2}$)
- SUM (one byte): Checksum

Response

H'06

- Response, H'06, (one byte): Response to selection of a new bit rate
When it is possible to set the bit rate, the response will be ACK.

Error Response

H'BF	ERROR
------	-------

- Error response, H'BF, (one byte): Error response to selection of new bit rate
- ERROR: (one byte): Error code
 - H'11: Sum checking error
 - H'24: Bit-rate selection error
 - The rate is not available.
 - H'25: Error in input frequency
 - This input frequency is not within the specified range.
 - H'26: Multiplication-ratio error
 - The ratio does not match an available ratio.
 - H'27: Operating frequency error
 - The frequency is not within the specified range.

(4) Receive Data Check

The methods for checking of receive data are listed below.

1. Input frequency

The received value of the input frequency is checked to ensure that it is within the range of minimum to maximum frequencies which matches the clock modes of the specified device. When the value is out of this range, an input-frequency error is generated.

2. Multiplication ratio

The received value of the multiplication ratio or division ratio is checked to ensure that it matches the clock modes of the specified device. When the value is out of this range, an input-frequency error is generated.

3. Operating frequency error

Operating frequency is calculated from the received value of the input frequency and the multiplication or division ratio. The input frequency is input to the LSI and the LSI is operated at the operating frequency. The expression is given below.

$$\begin{aligned} \text{Operating frequency} &= \text{Input frequency} \times \text{Multiplication ratio, or} \\ &\text{Operating frequency} = \text{Input frequency} \div \text{Division ratio} \end{aligned}$$

The calculated operating frequency should be checked to ensure that it is within the range of minimum to maximum frequencies which are available with the clock modes of the specified device. When it is out of this range, an operating frequency error is generated.

4. Bit rate

To facilitate error checking, the value (n) of clock select (CKS) in the serial mode register (SMR), and the value (N) in the bit rate register (BRR), which are found from the peripheral operating clock frequency (ϕ) and bit rate (B), are used to calculate the error rate to ensure that it is less than 4%. If the error is more than 4%, a bit rate error is generated. The error is calculated using the following expression:

$$\text{Error (\%)} = \left\{ \left[\frac{\phi \times 10^6}{(N + 1) \times B \times 64 \times 2^{(2 \times n - 1)}} \right] - 1 \right\} \times 100$$

When the new bit rate is selectable, the rate will be set in the register after sending ACK in response. The host will send an ACK with the new bit rate for confirmation and the boot program will response with that rate.

Confirmation H'06

- Confirmation, H'06, (one byte): Confirmation of a new bit rate

Response H'06

- Response, H'06, (one byte): Response to confirmation of a new bit rate

The sequence of new bit-rate selection is shown in figure 22.24.

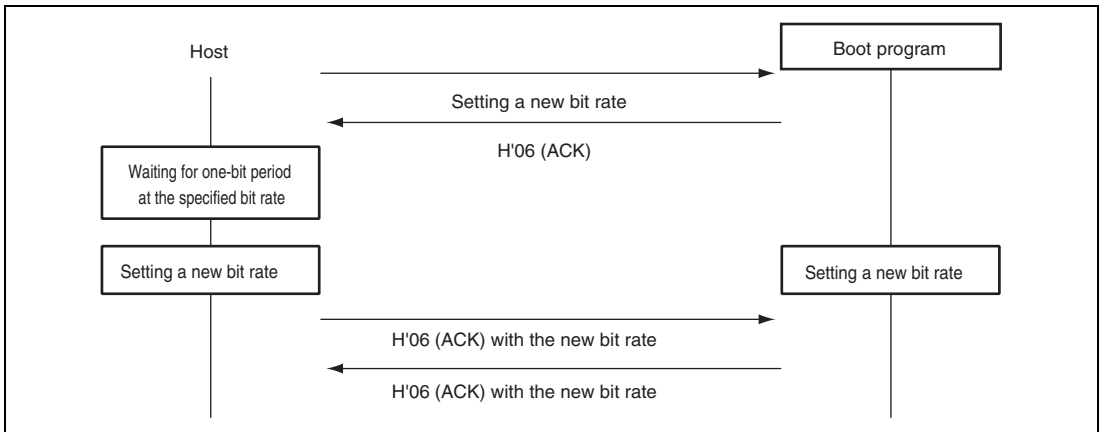

Figure 22.24 New Bit-Rate Selection Sequence

(5) Transition to Programming/Erasing State

The boot program will transfer the erasing program, and erase the user MATs and user boot MATs in that order. On completion of this erasure, ACK will be returned and will enter the programming/erasing state.

The host should select the device code, clock mode, and new bit rate with device selection, clock-mode selection, and new bit-rate selection commands, and then send the command for the transition to programming/erasing state. These procedures should be carried out before sending of the programming selection command or program data.

Command

H'40

- Command, H'40, (one byte): Transition to programming/erasing state

Response

H'06

- Response, H'06, (one byte): Response to transition to programming/erasing state
The boot program will send ACK when the user MAT and user boot MAT have been erased by the transferred erasing program.

Error Response

H'C0	H'51
------	------

- Error response, H'C0, (one byte): Error response for user boot MAT blank check
- Error code, H'51, (one byte): Erasing error
An error occurred and erasure was not completed.

(6) Command Error

A command error will occur when a command is undefined, the order of commands is incorrect, or a command is unacceptable. Issuing a clock-mode selection command before a device selection or an inquiry command after the transition to programming/erasing state command, are examples.

Error Response

H'80	H'xx
------	------

- Error response, H'80, (one byte): Command error
- Command, H'xx, (one byte): Received command

(7) Command Order

The order for commands in the inquiry selection state is shown below.

1. A supported device inquiry (H'20) should be made to inquire about the supported devices.
2. The device should be selected from among those described by the returned information and set with a device-selection (H'10) command.
3. A clock-mode inquiry (H'21) should be made to inquire about the supported clock modes.
4. The clock mode should be selected from among those described by the returned information and set.
5. After selection of the device and clock mode, inquiries for other required information should be made, such as the multiplication-ratio inquiry (H'22) or operating frequency inquiry (H'23), which are needed for a new bit-rate selection.
6. A new bit rate should be selected with the new bit-rate selection (H'3F) command, according to the returned information on multiplication ratios and operating frequencies.
7. After selection of the device and clock mode, the information of the user boot MAT and user MAT should be made to inquire about the user boot MATs information inquiry (H'24), user MATs information inquiry (H'25), erased block information inquiry (H'26), and programming unit inquiry (H'27).
8. After making inquiries and selecting a new bit rate, issue the transition to programming/erasing state command (H'40). The boot program will then enter the programming/erasing state.

(8) Programming/Erasing State

A programming selection command makes the boot program select the programming method, a 128-byte programming command makes it program the memory with data, and an erasing selection command and block erasing command make it erase the block. Table 22.16 lists the programming/erasing commands.

Table 22.16 Programming/Erasing Commands

Command	Command Name	Description
H'42	User boot MAT programming selection	Transfers the user boot MAT programming program
H'43	User MAT programming selection	Transfers the user MAT programming program
H'50	128-byte programming	Programs 128 bytes of data
H'48	Erasing selection	Transfers the erasing program
H'58	Block erasing	Erases a block of data
H'52	Memory read	Reads the contents of memory
H'4A	User boot MAT sum check	Checks the checksum of the user boot MAT
H'4B	User MAT sum check	Checks the checksum of the user MAT
H'4C	User boot MAT blank check	Checks the blank data of the user boot MAT
H'4D	User MAT blank check	Checks the blank data of the user MAT
H'4C	User boot MAT blank check	Checks whether the contents of the user boot MAT are blank
H'4D	User MAT blank check	Checks whether the contents of the user MAT are blank
H'4F	Boot program status inquiry	Inquires into the boot program's status

- Programming

Programming is executed by the programming selection and 128-byte programming commands.

Firstly, the host should send the programming selection command and select the programming method and programming MATs. There are two programming selection commands, and selection is according to the area and method for programming.

1. User boot MAT programming selection
2. User MAT programming selection

After issuing the programming selection command, the host should send the 128-byte programming command. The 128-byte programming command that follows the selection command represents the data programmed according to the method specified by the selection command. When more than 128-byte data is programmed, 128-byte commands should repeatedly be executed. Sending a 128-byte programming command with H'FFFFFFFF as the address will stop the programming. On completion of programming, the boot program will wait for selection of programming or erasing.

Where the sequence of programming operations that is executed includes programming with another method or of another MAT, the procedure must be repeated from the programming selection command.

The sequence for the programming selection and 128-byte programming commands is shown in figure 22.25.

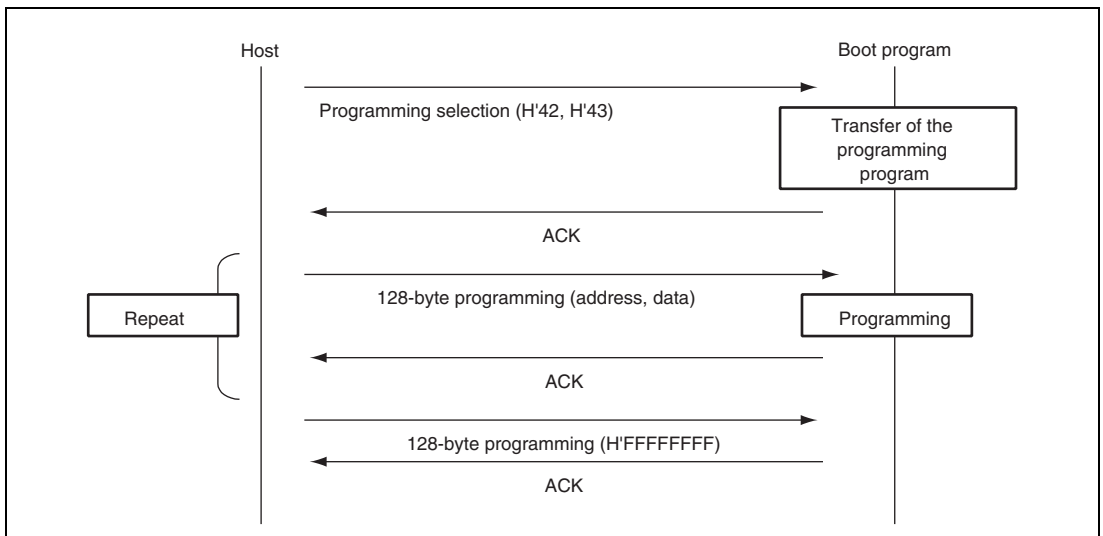

Figure 22.25 Programming Sequence

- Erasure

Erasure is executed by the erasure selection and block erasure commands.

Firstly, erasure is selected by the erasure selection command and the boot program then erases the specified block. The command should be repeatedly executed if two or more blocks are to be erased. Sending a block erasure command from the host with the block number H'FF will stop the erasure operating. On completion of erasing, the boot program will wait for selection of programming or erasing.

The sequence for the erasure selection and block erasure commands is shown in figure 22.26.

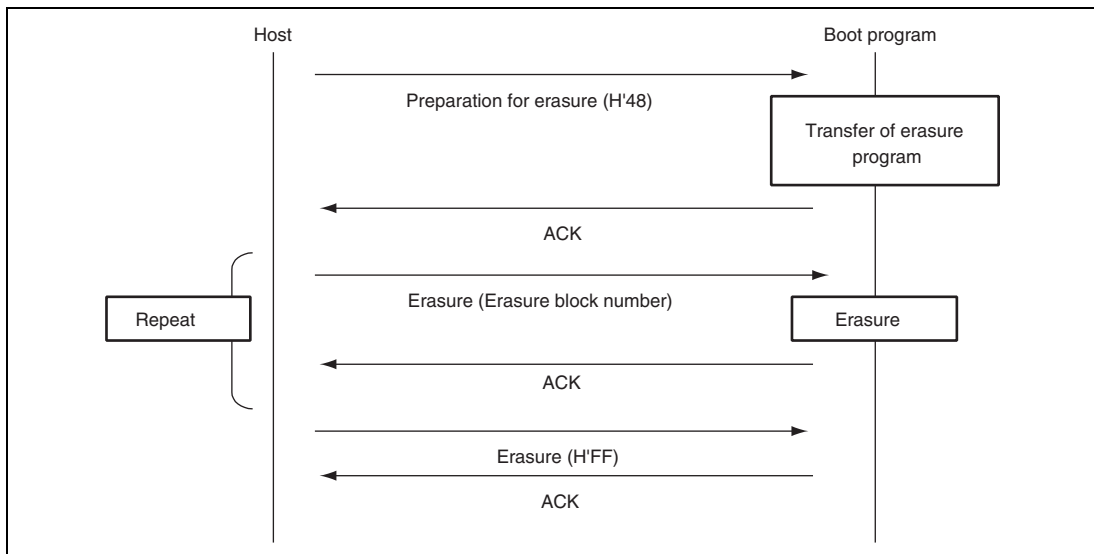

Figure 22.26 Erasure Sequence

(a) User Boot MAT Programming Selection

The boot program will transfer a programming program. The data is programmed to the user boot MATs by the transferred programming program.

Command

H'42

- Command, H'42, (one byte): User boot MAT programming selection

Response

H'06

- Response, H'06, (one byte): Response to user boot MAT programming selection
When the programming program has been transferred, the boot program will return ACK.

Error Response

H'C2	ERROR
------	-------

- Error response : H'C2 (1 byte): Error response to user boot MAT programming selection
- ERROR : (1 byte): Error code
H'54: Selection processing error (transfer error occurs and processing is not completed)

(b) User MAT Programming Selection

The boot program will transfer a program for user MAT programming selection. The data is programmed to the user MATs by the transferred program for programming.

Command

H'43

- Command, H'43, (one byte): User MAT programming selection

Response

H'06

- Response, H'06, (one byte): Response to user MAT programming selection
When the programming program has been transferred, the boot program will return ACK.

Error Response

H'C3	ERROR
------	-------

- Error response : H'C3 (1 byte): Error response to user MAT programming selection
- ERROR : (1 byte): Error code
H'54: Selection processing error (transfer error occurs and processing is not completed)

(c) 128-Byte Programming

The boot program will use the programming program transferred by the programming selection to program the user boot MATs or user MATs in response to 128-byte programming.

Command	H'50	Address						
	Data	...						
	...							
	SUM							

- Command, H'50, (one byte): 128-byte programming
- Programming Address (four bytes): Start address for programming
Multiple of the size specified in response to the programming unit inquiry
(i.e. H'00, H'01, H'00, H'00 : H'01000000)
- Program data (128 bytes): Data to be programmed
The size is specified in the response to the programming unit inquiry.
- SUM (one byte): Checksum

Response

H'06

- Response, H'06, (one byte): Response to 128-byte programming
On completion of programming, the boot program will return ACK.

Error Response

H'D0	ERROR
------	-------

- Error response, H'D0, (one byte): Error response for 128-byte programming
- ERROR: (one byte): Error code
 - H'11: Checksum Error
 - H'2A: Address error
The address is not in the specified MAT.
 - H'53: Programming error
A programming error has occurred and programming cannot be continued.

The specified address should match the unit for programming of data. For example, when the programming is in 128-byte units, the lower eight bits of the address should be H'00 or H'80. When there are less than 128 bytes of data to be programmed, the host should fill the rest with H'FF.

Sending the 128-byte programming command with the address of H'FFFFFFFF will stop the programming operation. The boot program will interpret this as the end of the programming and wait for selection of programming or erasing.

Command

H'50	Address	SUM
------	---------	-----

- Command, H'50, (one byte): 128-byte programming
- Programming Address (four bytes): End code is H'FF, H'FF, H'FF, H'FF.
- SUM (one byte): Checksum

Response

H'06

- Response, H'06, (one byte): Response to 128-byte programming
On completion of programming, the boot program will return ACK.

Error Response

H'D0	ERROR
------	-------

- Error Response, H'D0, (one byte): Error response for 128-byte programming
- ERROR: (one byte): Error code
 - H'11: Checksum error
 - H'53: Programming errorAn error has occurred in programming and programming cannot be continued.

(d) Erasure Selection

The boot program will transfer the erasure program. User MAT data is erased by the transferred erasure program.

Command

H'48

- Command, H'48, (one byte): Erasure selection

Response

H'06

- Response, H'06, (one byte): Response for erasure selection
After the erasure program has been transferred, the boot program will return ACK.

Error Response

H'C8	ERROR
------	-------

- Error Response, H'C8, (one byte): Error response to erasure selection
- ERROR: (one byte): Error code
 - H'54: Selection processing error (transfer error occurs and processing is not completed)

(e) Block Erasure

The boot program will erase the contents of the specified block.

Command	H'58	Size	Block number	SUM
---------	------	------	--------------	-----

- Command, H'58, (one byte): Erasure
- Size (one byte): The number of bytes that represents the erase block number
This is fixed to 1.
- Block number (one byte): Number of the block to be erased
- SUM (one byte): Checksum

Response	H'06
----------	------

- Response, H'06, (one byte): Response to Erasure
After erasure has been completed, the boot program will return ACK.

Error Response	H'D8	ERROR
----------------	------	-------

- Error Response, H'D8, (one byte): Response to Erasure
- ERROR (one byte): Error code
 - H'11: Sum check error
 - H'29: Block number error
Block number is incorrect.
 - H'51: Erasure error
An error has occurred during erasure.

On receiving block number H'FF, the boot program will stop erasure and wait for a selection command.

Command	H'58	Size	Block number	SUM
---------	------	------	--------------	-----

- Command, H'58, (one byte): Erasure
- Size, (one byte): The number of bytes that represents the block number
This is fixed to 1.
- Block number (one byte): H'FF
Stop code for erasure
- SUM (one byte): Checksum

Response	H'06
----------	------

- Response, H'06, (one byte): Response to end of erasure (ACK)
When erasure is to be performed after the block number H'FF has been sent, the procedure should be executed from the erasure selection command.

(f) Memory Read

The boot program will return the data in the specified address.

Command	H'52	Size	Area	Read address		
	Read size			SUM		

- Command: H'52 (1 byte): Memory read
- Size (1 byte): Amount of data that represents the area, read address, and read size (fixed at 9)
- Area (1 byte)

H'00: User boot MAT

H'01: User MAT

An address error occurs when the area setting is incorrect.

- Read address (4 bytes): Start address to be read from
- Read size (4 bytes): Size of data to be read
- SUM (1 byte): Checksum

Response	H'52	Read size							
	Data	...							
	SUM								

- Response: H'52 (1 byte): Response to memory read
- Read size (4 bytes): Size of data to be read
- Data (n bytes): Data for the read size from the read address
- SUM (1 byte): Checksum

Error Response	H'D2	ERROR
----------------	------	-------

- Error response: H'D2 (1 byte): Error response to memory read
- ERROR: (1 byte): Error code

H'11: Sum check error

H'2A: Address error

The read address is not in the MAT.

H'2B: Size error

The read size exceeds the MAT.

(g) User Boot MAT Sum Check

The boot program will return the byte-by-byte total of the contents of the bytes of the user-boot program, as a four-byte value.

Command

H'4A

- Command, H'4A, (one byte): Sum check for user-boot program

Response

H'5A	Size	Checksum of user boot program	SUM
------	------	-------------------------------	-----

- Response, H'5A, (one byte): Response to the sum check of user-boot program
- Size (one byte): The number of bytes that represents the checksum
This is fixed to 4.
- Checksum of user boot program (four bytes): Checksum of user boot MATs
The total of the data is obtained in byte units.
- SUM (one byte): Sum check for data being transmitted

(h) User MAT Sum Check

The boot program will return the byte-by-byte total of the contents of the bytes of the user program.

Command

H'4B

- Command, H'4B, (one byte): Sum check for user program

Response

H'5B	Size	Checksum of user program	SUM
------	------	--------------------------	-----

- Response, H'5B, (one byte): Response to the sum check of the user program
- Size (one byte): The number of bytes that represents the checksum
This is fixed to 4.
- Checksum of user boot program (four bytes): Checksum of user MATs
The total of the data is obtained in byte units.
- SUM (one byte): Sum check for data being transmitted

(i) User Boot MAT Blank Check

The boot program will check whether or not all user boot MATs are blank and return the result.

Command

H'4C

- Command, H'4C, (one byte): Blank check for user boot MAT

Response

H'06

- Response, H'06, (one byte): Response to the blank check of user boot MAT
If all user MATs are blank (H'FF), the boot program will return ACK.

Error Response

H'CC	H'52
------	------

- Error Response, H'CC, (one byte): Response to blank check for user boot MAT
- Error Code, H'52, (one byte): Erasure has not been completed.

(j) User MAT Blank Check

The boot program will check whether or not all user MATs are blank and return the result.

Command

H'4D

- Command, H'4D, (one byte): Blank check for user MATs

Response

H'06

- Response, H'06, (one byte): Response to the blank check for user MATs
If the contents of all user MATs are blank (H'FF), the boot program will return ACK.

Error Response

H'CD	H'52
------	------

- Error Response, H'CD, (one byte): Error response to the blank check of user MATs.
- Error code, H'52, (one byte): Erasure has not been completed.

(k) Boot Program State Inquiry

The boot program will return indications of its present state and error condition. This inquiry can be made in the inquiry/selection state or the programming/erasing state.

Command

H'4F

- Command, H'4F, (one byte): Inquiry regarding boot program's state

Response

H'5F	Size	Status	ERROR	SUM
------	------	--------	-------	-----

- Response, H'5F, (one byte): Response to boot program state inquiry
- Size (one byte): The number of bytes. This is fixed to 2.
- Status (one byte): State of the boot program
- ERROR (one byte): Error status
 - ERROR = 0 indicates normal operation.
 - ERROR = 1 indicates error has occurred.
- SUM (one byte): Sum check

Table 22.17 Status Code

Code	Description
H'11	Device selection wait
H'12	Clock mode selection wait
H'13	Bit rate selection wait
H'1F	Programming/erasing state transition wait (bit rate selection is completed)
H'31	Programming state for erasure
H'3F	Programming/erasing selection wait (erasure is completed)
H'4F	Program data receive wait
H'5F	Erase block specification wait (erasure is completed)

Table 22.18 Error Code

Code	Description
H'00	No error
H'11	Sum check error
H'12	Program size error
H'21	Device code mismatch error
H'22	Clock mode mismatch error
H'24	Bit rate selection error
H'25	Input frequency error
H'26	Multiplication ratio error
H'27	Operating frequency error
H'29	Block number error
H'2A	Address error
H'2B	Data length error
H'51	Erase error
H'52	Erase incomplete error
H'53	Programming error
H'54	Selection processing error
H'80	Command error
H'FF	Bit-rate-adjustment confirmation error

22.14 Usage Notes

1. The initial state of the product at its shipment is in the erased state. For the product whose revision of erasing is undefined, we recommend to execute automatic erasure for checking the initial state (erased state) and compensating.
2. For the PROM programmer suitable for programmer mode in this LSI and its program version, refer to the instruction manual of the socket adapter.
3. If the socket, socket adapter, or product index does not match the specifications, too much current flows and the product may be damaged.
4. Use a PROM programmer that supports the device with 1-Mbyte on-chip flash memory and 3.3-V programming voltage. Use only the specified socket adapter.
5. Do not turn off the Vcc power supply nor remove the chip from the PROM programmer during programming/erasure in which a high voltage is applied to the flash memory. Doing so may damage the flash memory permanently. If a reset is input, the reset must be released after the reset input period of at least 100 μ s.
6. The flash memory is not accessible until FKEY is cleared after programming/erasure starts. If the operating mode is changed and this LSI is restarted by a reset immediately after programming/erasure has finished, secure the reset input period (period of $\overline{\text{RES}} = 0$) of at least 100 μ s. Transition to the reset state during programming/erasure is inhibited. If a reset is input accidentally, the reset must be released after the reset input period of at least 100 μ s.
7. At powering on the Vcc power supply, fix the RES pin to low and set the flash memory to hardware protection state. This power on timing must also be satisfied at a power-off and power-on caused by a power failure and other factors.
8. In on-board programming mode or programmer mode, programming of the 128-byte programming-unit block must be performed only once. Perform programming in the state where the programming-unit block is fully erased.
9. When the chip is to be reprogrammed with the programmer after execution of programming or erasure in on-board programming mode, it is recommended that automatic programming is performed after execution of automatic erasure.
10. To program the flash memory, the program data and program must be allocated to addresses which are higher than those of the external interrupt vector table and H'FF must be written to all the system reserved areas in the exception handling vector table.
11. The programming program that includes the initialization routine and the erasing program that includes the initialization routine are each 4 Kbytes or less. Accordingly, when the CPU clock frequency is 35 MHz, the download for each program takes approximately 60 μ s at the maximum.

12. A programming/erasing program for the flash memory used in a conventional F-ZTAT H8, H8S microcomputer which does not support download of the on-chip program by setting the SCO bit in FCCS to 1 cannot run in this LSI. Be sure to download the on-chip program to execute programming/erasure of the flash memory in this F-ZTAT H8SX microcomputer.
13. Unlike a conventional F-ZTAT H8 or H8S microcomputers, measures against a program crash are not taken by WDT while programming/erasing and downloading a programming/erasing program. When needed, measures should be taken by user. A periodic interrupt generated by the WDT can be used as the measures, as an example. In this case, the interrupt generation period should take into consideration time to program/erase the flash memory.
14. When downloading the programming/erasing program, do not clear the SCO bit in FCCS to 0 immediately after setting it to 1. Otherwise, download cannot be performed normally. Immediately after executing the instruction to set the SCO bit to 1, dummy read of the FCCS must be executed twice.
15. The contents of general registers ER0 and ER1 are not saved during download of an on-chip program, initialization, programming, or erasure. When needed, save the general registers before a download request or before execution of initialization, programming, or erasure using the procedure program.

Section 23 Boundary Scan

This LSI has boundary scan function, which is a serial I/O interface based on the JTAG (Joint Test Action Group, IEEE Std.1149.1 and IEEE Standard Test Access Port and Boundary-Scan Architecture).

23.1 Features

- Boundary scan valid single chip mode when the EMLE pin= 0 in MCU operating mode 3
- P62, P63, P64, P65, and WDTOVF are pins only for boundary scan when boundary scan is valid
- Six test modes:
 - BYPASS mode
 - EXTEST mode
 - SAMPLE/PRELOAD mode
 - CLAMP mode
 - HIGHZ mode
 - IDCODE mode

23.2 Block Diagram of Boundary Scan Function

Figure 23.1 shows the block diagram of the boundary scan function.

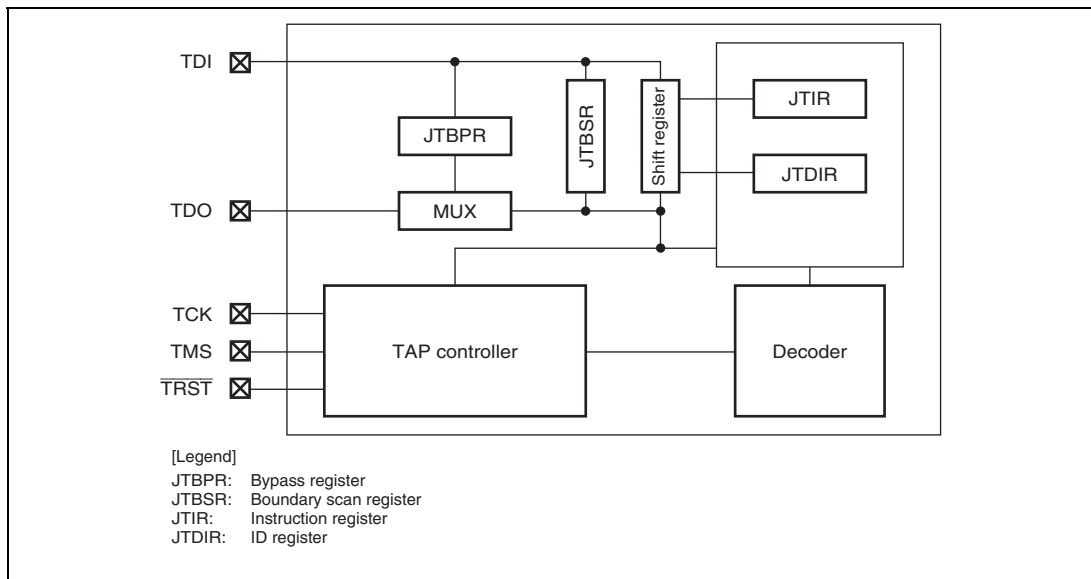

Figure 23.1 Block Diagram of Boundary Scan Function

23.3 Pin Configuration

Table 23.1 shows the I/O pins used in the boundary scan function.

Table 23.1 Pin Configuration

Pin Name	I/O	Description
TCK	Input	Test clock input pin Clock signal for boundary scan. Input the clock the duty cycle of which is 50 percent when boundary scan function is used.
TMS	Input	Test mode select pin
TDI	Input	Test data input pin
TDO	Output	Test data output pin
TRST	Input	Test reset input pin

23.4 Register Descriptions

Boundary scan has the following four registers. These registers cannot be accessed from the CPU.

- Instruction register (JTIR)
- Bypass register (JTBPR)
- Boundary scan register (JTBSR)
- IDCODE register (JTIDR)

Instructions can be input to the instruction register (JTIR) via the test data input pin (TDI) by serial transfer. The bypass register (JTBPR), which is a 1-bit register, is connected between the TDI and TDO pins in BYPASS mode. The boundary scan register (JTBSR), which is a JTBSR-bit register (see table 23.4), is connected between the TDI and TDO pins when test data are being shifted in. None of the registers is accessible from the CPU.

Table 23.2 shows the availability of serial transfer for the registers.

Table 23.2 Serial Transfers for Registers

Register Abbreviation	Serial Input	Serial Output
JTIR	Available	Not available
JTBPR	Available	Available
JTBSR	Available	Available
JTID	Not available	Available

23.4.1 Instruction Register (JTIR)

JTIR is a 16-bit register. JTAG instructions can be transferred to JTIR by serial input from the TDI pin. JTIR is initialized when the $\overline{\text{TRST}}$ signal is low level, when the TAP controller is in the Test-Logic-Reset state, and when this LSI is placed in hardware standby mode. JTIR is not initialized by a reset or entry to software standby mode. Instructions must be serially transferred in 4-bit units. When an instruction with more than 4 bits is being transferred, the last four bits of the serial data are stored.

Bit	15	14	13	12	11	10	9	8
Bit Name	TS3	TS2	TS1	TS0	—	—	—	—
Initial Value	0	0	0	0	0	0	0	0
R/W	—	—	—	—	—	—	—	—
Bit	7	6	5	4	3	2	1	0
Bit Name	—	—	—	—	—	—	—	—
Initial Value	0	0	0	0	0	0	0	0
R/W	—	—	—	—	—	—	—	—

Bit	Bit Name	Initial Value	R/W	Descriptions
15 to 12	TS[3:0]	All 0	—	Test Bit Set Specify an instruction as shown in table 23.3.
11 to 0	—	All 0	—	Reserved These bits are always read as 0. The write value should always 0.

Table 23.3 Boundary Scan Instructions

TS3	TS2	TS1	TS0	Instruction
0	0	0	0	EXTEST
0	0	0	1	IDCODE (initial value)
0	0	1	0	CLAMP
0	0	1	1	HIGHZ
0	1	0	0	SAMPLE/PRELOAD
0	1	0	1	Reserved
0	1	1	0	Reserved
0	1	1	1	Reserved
1	0	0	0	Reserved
1	0	0	1	Reserved
1	0	1	0	Reserved
1	0	1	1	Reserved
1	1	0	0	Reserved
1	1	0	1	Reserved
1	1	1	0	Reserved
1	1	1	1	BYPASS

23.4.2 Bypass Register (JTBPR)

JTBPR is a 1-bit register and is connected between the TDI and TDO pins when JTIR is set to BYPASS mode. JTBPR cannot be read from or written to by the CPU.

23.4.3 Boundary Scan Register (JTBSR)

JTBSR is a shift register to control the external input and output pins of this LSI and is distributed across the pads. The initial values are undefined. JTBSR cannot be accessed by the CPU. The EXTEST, SAMPLE/PRELOAD, CLAMP, and HIGHZ instructions are issued to apply JTBSR in boundary-scan testing conformant to the JTAG standard.

Table 23.4 shows the correspondence between the JTBSR bits and the pins of this LSI.

Table 23.4 Relationship between Pins and JTBSR Bits

From TDI

Pin No.	Pin Name	Input/Output	Bit Name
From TDI			
3	PB3	Input	295
		Output enable	294
		Output	293
4	MD2	Input	289
5	PF7	Input	274
		Output enable	273
		Output	272
6	PF6	Input	271
		Output enable	270
		Output	269
7	PF5	Input	268
		Output enable	267
		Output	266
8	PF4	Input	265
		Output enable	264
		Output	263
9	PF3	Input	262
		Output enable	261
		Output	260
11	PF2	Input	259
		Output enable	258
		Output	257
12	PF1	Input	256
		Output enable	255
		Output	254

Pin No.	Pin Name	Input/Output	Bit Name
13	PF0	Input	253
		Output enable	252
		Output	251
14	PE7	Input	250
		Output enable	249
		Output	248
15	PE6	Input	247
		Output enable	246
		Output	245
16	PE5	Input	244
		Output enable	243
		Output	242
18	PE4	Input	241
		Output enable	240
		Output	239
20	PE3	Input	238
		Output enable	237
		Output	236
21	PE2	Input	235
		Output enable	234
		Output	233
22	PE1	Input	232
		Output enable	231
		Output	230
23	PE0	Input	229
		Output enable	228
		Output	227
24	PD7	Input	226
		Output enable	225
		Output	224
25	PD6	Input	223
		Output enable	222
		Output	221
27	PD5	Input	220
		Output enable	219
		Output	218
28	PD4	Input	217
		Output enable	216
		Output	215

Pin No.	Pin Name	Input/Output	Bit Name
29	PD3	Input	214
		Output enable	213
		Output	212
30	PD2	Input	211
		Output enable	210
		Output	209
31	PD1	Input	208
		Output enable	207
		Output	206
32	PD0	Input	205
		Output enable	204
		Output	203
34	P20	Input	183
		Output enable	182
		Output	181
35	P21	Input	180
		Output enable	179
		Output	178
36	P22	Input	177
		Output enable	176
		Output	175
37	P23	Input	174
		Output enable	173
		Output	172
38	P24	Input	171
		Output enable	170
		Output	169
39	P25	Input	168
		Output enable	167
		Output	166
43	P30	Input	165
		Output enable	164
		Output	163
45	P31	Input	162
		Output enable	161
		Output	160
46	P32	Input	159
		Output enable	158
		Output	157

Pin No.	Pin Name	Input/Output	Bit Name
40	P26	Input	156
		Output enable	155
		Output	154
41	P27	Input	153
		Output enable	152
		Output	151
52	NMI	Input	150
47	P33	Input	149
		Output enable	148
		Output	147
48	P34	Input	146
		Output enable	145
		Output	144
53	PH0	Input	143
		Output enable	142
		Output	141
54	PH1	Input	140
		Output enable	139
		Output	138
55	PH2	Input	137
		Output enable	136
		Output	135
56	PH3	Input	134
		Output enable	133
		Output	132
61	PH7	Input	131
		Output enable	130
		Output	129
58	PH4	Input	128
		Output enable	127
		Output	126
59	PH5	Input	125
		Output enable	124
		Output	123
60	PH6	Input	122
		Output enable	121
		Output	120

Pin No.	Pin Name	Input/Output	Bit Name
64	PI1	Input	119
		Output enable	118
		Output	117
65	PI2	Input	116
		Output enable	115
		Output	114
66	PI3	Input	113
		Output enable	112
		Output	111
63	PI0	Input	110
		Output enable	109
		Output	108
68	PI4	Input	107
		Output enable	106
		Output	105
69	PI5	Input	104
		Output enable	103
		Output	102
71	PI7	Input	101
		Output enable	100
		Output	99
70	PI6	Input	98
		Output enable	97
		Output	96
72	P10	Input	95
		Output enable	94
		Output	93
73	P11	Input	92
		Output enable	91
		Output	90
74	P12	Input	89
		Output enable	88
		Output	87
75	P13	Input	86
		Output enable	85
		Output	84
79	P14	Input	77
		Output enable	76
		Output	75

Pin No.	Pin Name	Input/Output	Bit Name
80	P15	Input	74
		Output enable	73
		Output	72
86	P16	Input	71
		Output enable	70
		Output	69
87	P17	Input	68
		Output enable	67
		Output	66
50	P36	Input	65
		Output enable	64
		Output	63
49	P35	Input	62
		Output enable	61
		Output	60
89	P60	Input	59
		Output enable	58
		Output	57
51	P37	Input	56
		Output enable	55
		Output	54
90	P61	Input	53
		Output enable	52
		Output	51
97	MD0	Input	50
109	MD1	Input	43
110	PA0	Input	32
		Output enable	31
		Output	30
111	PA1	Input	29
		Output enable	28
		Output	27
112	PA2	Input	26
		Output enable	25
		Output	24
113	PA3	Input	23
		Output enable	22
		Output	21

Pin No.	Pin Name	Input/Output	Bit Name
114	PA4	Input	20
		Output enable	19
		Output	18
115	PA5	Input	17
		Output enable	16
		Output	15
116	PA6	Input	14
		Output enable	13
		Output	12
118	PA7	Input	11
		Output enable	10
		Output	9
120	PB0	Input	8
		Output enable	7
		Output	6
1	PB1	Input	5
		Output enable	4
		Output	3
2	PB2	Input	2
		Output enable	1
		Output	0
To TDO			

23.4.4 IDCODE Register (JTID)

JTID is a 32-bit register. JTID data is output from the TDO pin when the IDCODE instruction has been executed. Data cannot be written to JTID from the TDI pin.

Bit	31	30	29	28	27	26	25	24	23	22	21	20	19	18	17	16
Bit Name	DID31	DID30	DID29	DID28	DID27	DID26	DID25	DID24	DID23	DID22	DID21	DID20	DID19	DID18	DID17	DID16
Initial Value	-	-	-	-	-	-	-	-	-	-	-	-	-	-	-	-
R/W	R/W	R/W	R/W	R/W	R/W	R/W	R/W	R/W	R/W	R/W	R/W	R/W	R/W	R/W	R/W	R/W
Bit	15	14	13	12	11	10	9	8	7	6	5	4	3	2	1	0
Bit Name	DID15	DID14	DID13	DID12	DID11	DID10	DID9	DID8	DID7	DID6	DID5	DID4	DID3	DID2	DID1	DID0
Initial Value	-	-	-	-	-	-	-	-	-	-	-	-	-	-	-	-
R/W	R/W	R/W	R/W	R/W	R/W	R/W	R/W	R/W	R/W	R/W	R/W	R/W	R/W	R/W	R/W	R/W

Bit	Bit Name	Initial Value	R/W	Descriptions
31 to 0	DID31 to DID0	H'0803A447	—	Device ID JTID is a register the value showing the decide IDCODE is fixed.

23.5 Operations

The boundary scan functionality is valid when the EMLE pin is set to 0 and this LSI is in MCU operation mode 3.

23.5.1 TAP Controller

Figure 23.2 shows the state transition diagram of the TAP controller.

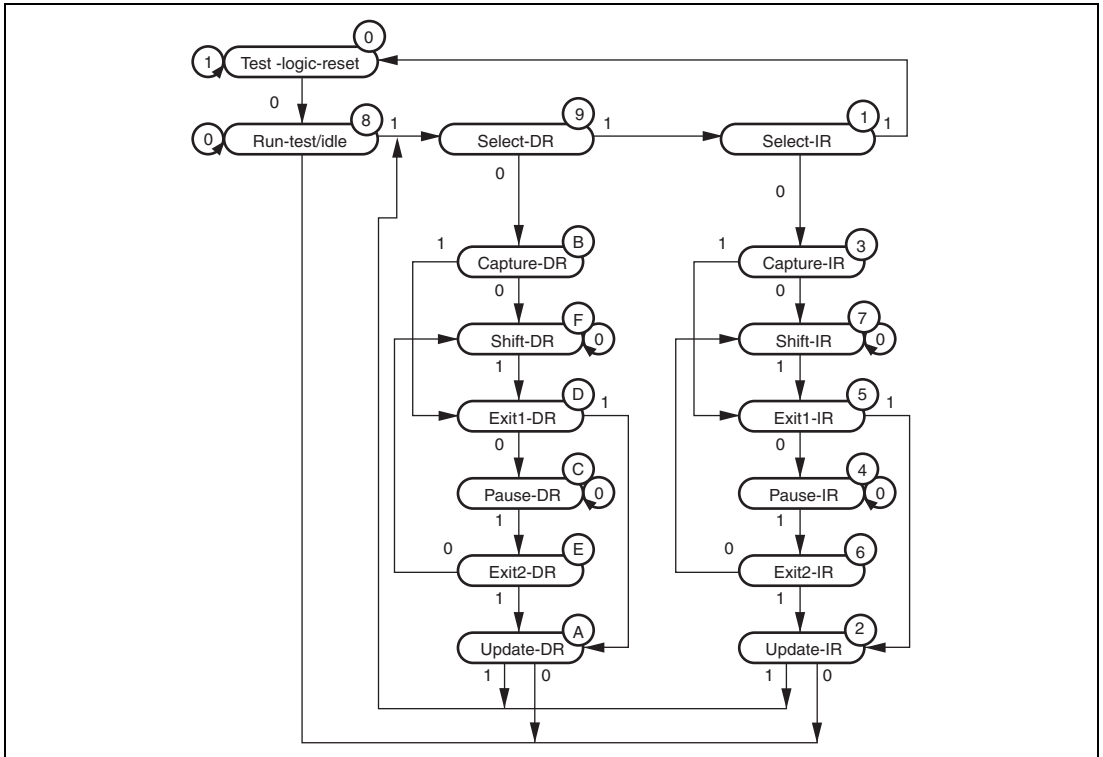

Figure 23.2 State Transition of TAP Controller

23.5.2 Commands

(1) **BYPASS (Instruction Code: B'1111)**

The BYPASS instruction is an instruction that drives the bypass register (JTBPR). This instruction shortens the shift path, facilitating the transfer of serial data to other LSIs on a printed-circuit board at higher speeds. While this instruction is being executed, the test circuit has no effect on the system circuits.

The bypass register (JTBPR) is connected between the TDI and TDO pins. Bypass operation is initiated from shift-DR operation. The TDO is at 0 in the first clock cycle in the shift-DR state; in the subsequent clock cycles, the TDI signal is output on the TDO pin.

(2) **EXTEST (Instruction Code: B'0000)**

The EXTEST instruction is used to test external circuits when this LSI is installed on the printed circuit board. If this instruction is executed, output pins are used to output test data (specified by the SAMPLE/PRELOAD instruction) from the boundary scan register to the print circuit board, and input pins are used to input test result.

(3) **SAMPLE/PRELOAD (Instruction Code: B'0100)**

The SAMPLE/PRELOAD instruction is used to input data from the LSI internal circuits to the boundary scan register, output data from scan path, and reload the data to the scan path. While this instruction is executed, input signals are directly input to the LSI and output signals are also directly output to the external circuits. The LSI system circuit is not affected by this function.

In SAMPLE operation, the boundary scan register latches the snap shot of data transferred from input pins to internal circuit or data transferred from internal circuit to output pins. The latched data is read from the scan path. The scan register latches the snap data at the rising edge of the TCK in Capture-DR state. The scan register latches snap shot without affecting the LSI normal operation.

In PRELOAD operation, initial value is written from the scan path to the parallel output latch of the boundary scan register prior to the EXTEST instruction execution. If the EXTEST is executed without executing this PRELOAD operation, undefined values are output from the beginning to the end (transfer to the output latch) of the EXTEST sequence. (In EXTEST instruction, output parallel latches are always output to the output pins.)

(4) IDCODE (Instruction Code: B'0001)

When the IDCODE instruction is selected, IDCODE register value is output to the TDO in Shift-DR state of the TAP controller. In this case, IDCODE register value is output from the LSB. During this instruction execution, test circuit does not affect the system circuit. INSTR is initialized by the IDCODE instruction in Test-Logic-Reset state of the TAP controller.

(5) CLAMP (Instruction Code: B'0010)

When the CLAMP instruction is selected, output pins output the boundary scan register value which was specified by the SAMPLE/PRELOAD instruction in advance. While the CLAMP instruction is selected, the status of boundary scan register is maintained regardless of the TAP controller state. BYPASS is connected between TDI and TDO, the same operation as BYPASS instruction can be achieved.

(6) HIGHZ (Instruction Code: B'0011)

When the HIGHZ instruction is selected, all output pins enter high-impedance state. While the HIGHZ instruction is selected, the status of boundary scan register is maintained regardless of the state of the TAP controller.

BYPASS is connected between TDI and TDO pins, leading to the same operation as when the BYPASS instruction has been selected.

23.6 Usage Notes

1. In serial transfer, data are input or output in LSB order (see figure 23.3).

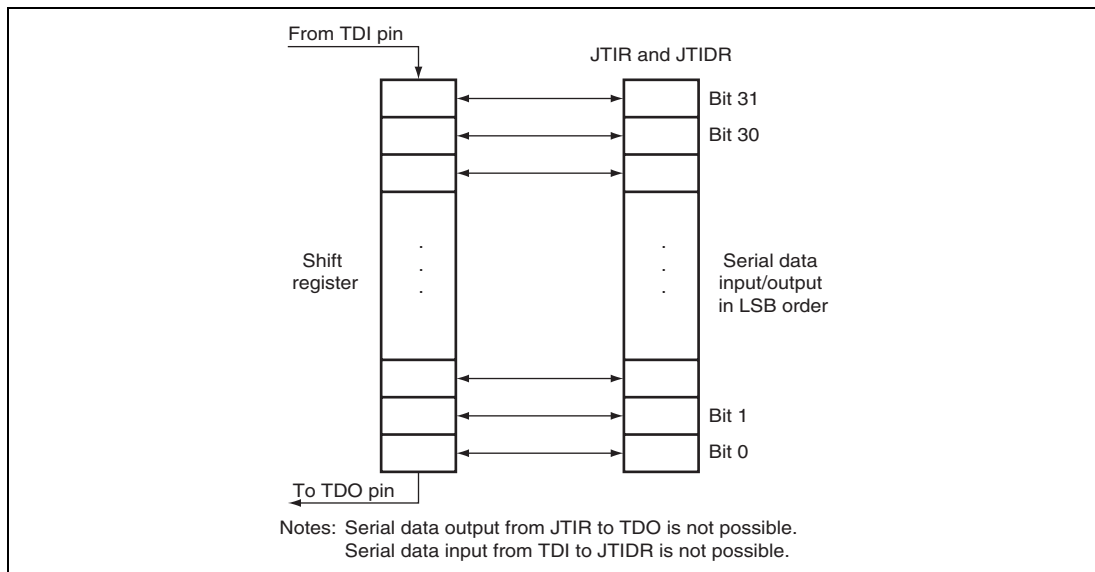

Figure 23.3 Serial Data Input/Output

2. If a pin with open-drain function is SAMPLEd while its open-drain function is enabled and while the corresponding OUT register is set to 1, the corresponding Control register is cleared to 0 (the pin status is Hi-Z). If the pin is SAMPLEd while the corresponding OUT register is cleared to 0, the corresponding Control register is set to 1 (the pin status is 0).
3. Pins of the boundary scan (TCK, TDI, TMS, and $\overline{\text{TRST}}$) have to be pulled up by pull-up resistors.
4. Power supply pins (VCC, VCL, VSS, AVCC, AVSS, AVref, PLLVCC, and PLLVSS) cannot be boundary-scanned.
5. Clock pins (EXTAL and XTAL) cannot be boundary-scanned.
6. Reset and standby signals ($\overline{\text{RES}}$ and $\overline{\text{STBY}}$) cannot be boundary-scanned.
7. Boundary scan pins (TCK, TMS, $\overline{\text{TRST}}$, TDI, and TDO) cannot be boundary-scanned.
8. The boundary scan function is not available when this LSI are in the following states.
 - (1) Reset state
 - (2) Hardware standby mode, software standby mode, and deep software standby mode

Section 24 Clock Pulse Generator

This LSI has an on-chip clock pulse generator (CPG) that generates the system clock ($I\phi$), peripheral module clock ($P\phi$), and external bus clock ($B\phi$). The clock pulse generator consists of a main clock oscillator, frequency divider, PLL (phase-locked loop) circuit, waveform generation circuit, and selector. Figure 24.1 is a block diagram of the clock pulse generator. The frequency divider, PLL circuit, and selector can change the clock frequency. Software changes the frequency through the setting of the system clock control register (SCKCR).

This LSI supports five clocks: a system clock provided to the CPU and bus masters, a peripheral module clock provided to the peripheral modules, an external bus clock provided to the external bus. Frequencies of the peripheral module clock, the external bus clock, and the system clock can be set independently, although the peripheral module clock and the external bus clock operate with the frequency lower than the system clock frequency.

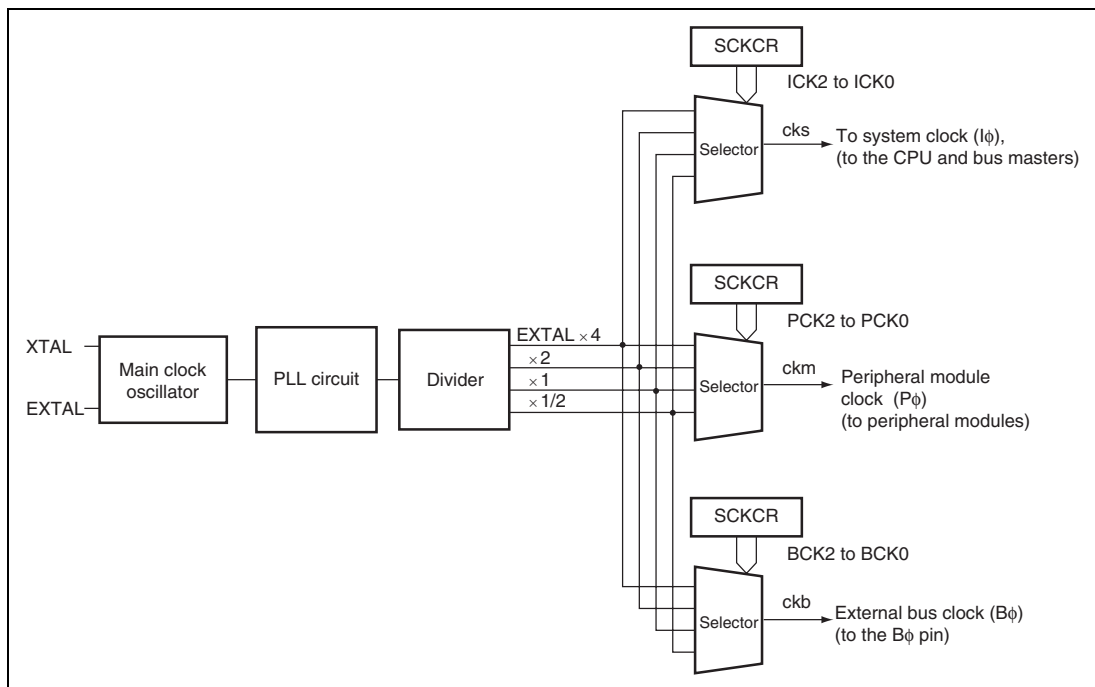

Figure 24.1 Block Diagram of Clock Pulse Generator

Table 24.1 Selection of Clock Pulse Generator

EXTAL Input Clock Frequency	I ϕ /P ϕ /B ϕ
8 MHz to 18 MHz	EXTAL $\times 4$, $\times 2$, $\times 1$, $\times 1/2$

24.1 Register Description

The clock pulse generator has the following registers.

- System clock control register (SCKCR)

24.1.1 System Clock Control Register (SCKCR)

SCKCR controls B ϕ output control and frequencies of the system, peripheral module, and external bus clocks.

Bit	15	14	13	12	11	10	9	8
Bit Name	PSTOP1	—	—	—	—	ICK2	ICK1	ICK0
Initial Value	0	0	0	0	0	0	1	0
R/W	R/W	R/W	R/W	R/W	R/W	R/W	R/W	R/W
Bit	7	6	5	4	3	2	1	0
Bit Name	—	PCK2	PCK1	PCK0	—	BCK2	BCK1	BCK0
Initial Value	0	0	1	0	0	0	1	0
R/W	R/W	R/W	R/W	R/W	R/W	R/W	R/W	R/W

Bit	Bit Name	Initial Value	R/W	Description
15	PSTOP1	0	R/W	B ϕ Clock Output Enable Controls ϕ output on PA7. <ul style="list-style-type: none"> • Normal operation 0: ϕ output 1: Fixed high

Bit	Bit Name	Initial Value	R/W	Description
14 to 11	—	All 0	R/W	Reserved Although these bits are readable/writable, only 0 should be written to.
10	ICK2	0	R/W	System Clock ($I\phi$) Select
9	ICK1	1	R/W	These bits select the frequency of the system clock provided to the CPU, DMAC, and DTC. The ratio to the input clock is as follows: ICK (2:0) 000: $\times 4$ 001: $\times 2$ 010: $\times 1$ 011: $\times 1/2$ 1xx: Setting prohibited The frequencies of the peripheral module clock and external bus clock change to the same frequency as the system clock if the frequency of the system clock is lower than that of the two clocks.
8	ICK0	0	R/W	
7	—	0	R/W	
6	PCK2	0	R/W	
5	PCK1	1	R/W	
4	PCK0	0	R/W	Peripheral Module Clock ($P\phi$) Select These bits select the frequency of the peripheral module clock. The ratio to the input clock is as follows: PCK (2:0) 000: $\times 4$ 001: $\times 2$ 010: $\times 1$ 011: $\times 1/2$ 1xx: Setting prohibited The frequency of the peripheral module clock should be lower than that of the system clock. Though these bits can be set so as to make the frequency of the peripheral module clock higher than that of the system clock, the clocks will have the same frequency in reality.

Bit	Bit Name	Initial Value	R/W	Description
3	—	0	R/W	Reserved Although this bit is readable/writable, only 0 should be written to.
2	BCK2	0	R/W	External Bus Clock (B ϕ) Select
1	BCK1	1	R/W	These bits select the frequency of the external bus clock. The ratio to the input clock is as follows: BCK (2:0) 000: $\times 4$ 001: $\times 2$ 010: $\times 1$ 011: $\times 1/2$ 1xx: Setting prohibited The frequency of the external bus clock should be lower than that of the system clock. Though these bits can be set so as to make the frequency of the external bus clock higher than that of the system clock, the clocks will have the same frequency in reality.
0	BCK0	0	R/W	

Note: x: Don't care

24.2 Oscillator

Clock pulses can be supplied by connecting a crystal resonator, or by input of an external clock.

24.2.1 Connecting Crystal Resonator

A crystal resonator can be connected as the example in figure 24.2. Select the damping resistance R_d according to table 24.2. An AT-cut parallel-resonance type should be used.

When providing the clock from the crystal resonator, the frequency should be in the range of 8 to 18 MHz.

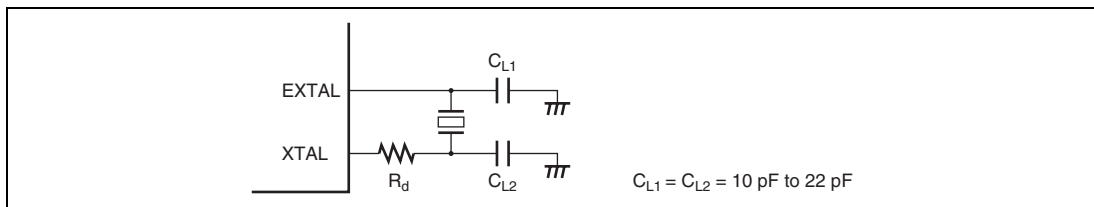

Figure 24.2 Connection of Crystal Resonator (Example)

Table 24.2 Damping Resistance Value

Frequency (MHz)	8	12	16	18
R_d (Ω)	200	0	0	0

Figure 24.3 shows an equivalent circuit of the crystal resonator. Use a crystal resonator that has the characteristics shown in table 24.3.

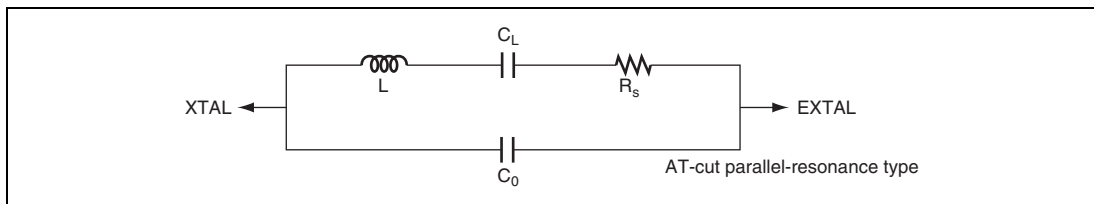

Figure 24.3 Crystal Resonator Equivalent Circuit

Table 24.3 Crystal Resonator Characteristics

Frequency (MHz)	8	12	16	18
R_s Max. (Ω)	80	60	50	40
C_0 Max. (pF)	7			

24.2.2 External Clock Input

An external clock signal can be input as the examples in Figure 24.4. When the XTAL pin is left open, make the parasitic capacitance less than 10 pF. When the counter clock is input to the XTAL pin, put the external clock in high level during standby mode.

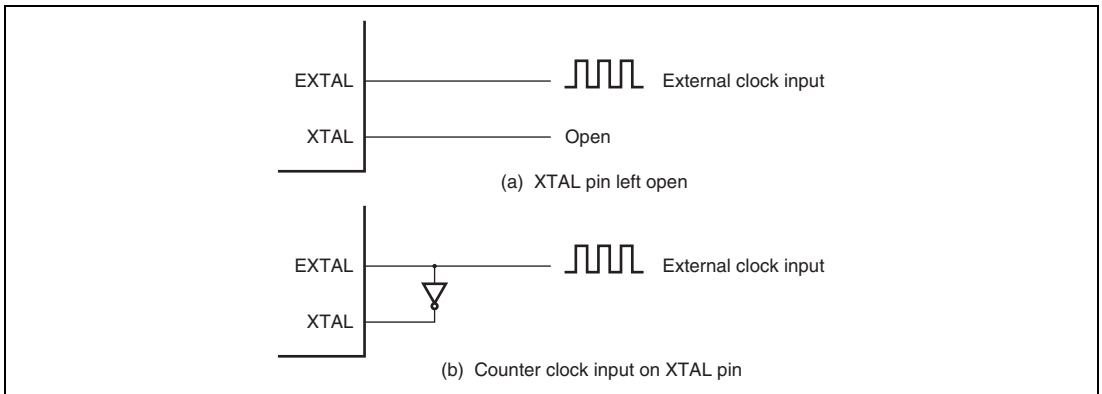
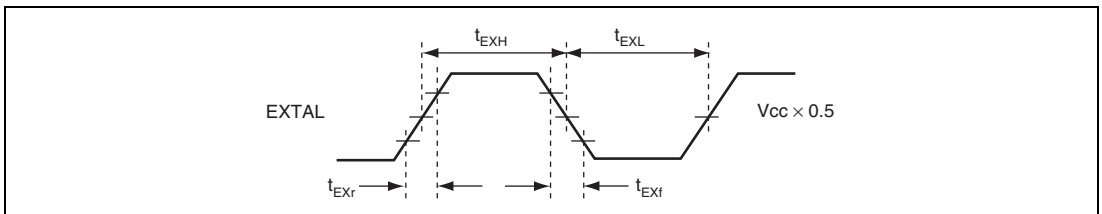
**Figure 24.4 External Clock Input (Examples)****Figure 24.5 External Clock Input Timing**

24.3 PLL Circuit

The PLL circuit has the function of multiplying the frequency of the clock from the oscillator by a factor of 4. The frequency multiplication rate is fixed. The phase difference is controlled so that the timing of the rising edge of the internal clock is the same as that of the EXTAL pin signal.

24.4 Frequency Divider

The frequency divider divides the PLL clock to generate a 1/2, 1/4, or 1/8 clock. After the bits ICK2 to ICK0, PCK 2 to PCK0, and BCK2 to BCK0 are updated, this LSI operates with the updated frequency.

24.5 Usage Notes

24.5.1 Notes on Clock Pulse Generator

1. The following points should be noted since the frequency of ϕ ($I\phi$: system clock, $P\phi$: peripheral module clock, $B\phi$: external bus clock) supplied to each module changes according to the setting of SCKCR.

Select a clock division ratio that is within the operation guaranteed range of clock cycle time t_{cye} shown in the AC timing of electrical characteristics.

The frequency should be set under the conditions of $8 \text{ MHz} \leq I\phi \leq 50 \text{ MHz}$, $8 \text{ MHz} \leq P\phi \leq 35 \text{ MHz}$, and $8 \text{ MHz} \leq B\phi \leq 50 \text{ MHz}$.

2. All the on-chip peripheral modules (except for the DMAC and DTC) operate on the $P\phi$. Note therefore that the time processing of modules such as a timer and SCI differs before and after changing the clock division ratio.

In addition, wait time for clearing software standby mode differs by changing the clock division ratio. For details, see section 25.7.3, Setting Oscillation Settling Time after Exit from Software Standby Mode.

3. The relationship among the system clock, peripheral module clock, and external bus clock is $I\phi \geq P\phi$ and $I\phi \geq B\phi$. In addition, the system clock setting has the highest priority. Accordingly, $P\phi$ or $B\phi$ may have the frequency set by bits ICK2 to ICK0 regardless of the settings of bits PCK2 to PCK0 or BCK2 to BCK0.
4. Note that the frequency of ϕ will be changed in the middle of a bus cycle when setting SCKCR while executing the external bus cycle with the write-data-buffer function.
5. Figure 24.6 shows the clock modification timing. After a value is written to SCKCR, this LSI waits for the current bus cycle to complete. After the current bus cycle completes, each clock frequency will be modified within one cycle (worst case) of the external input clock ϕ .

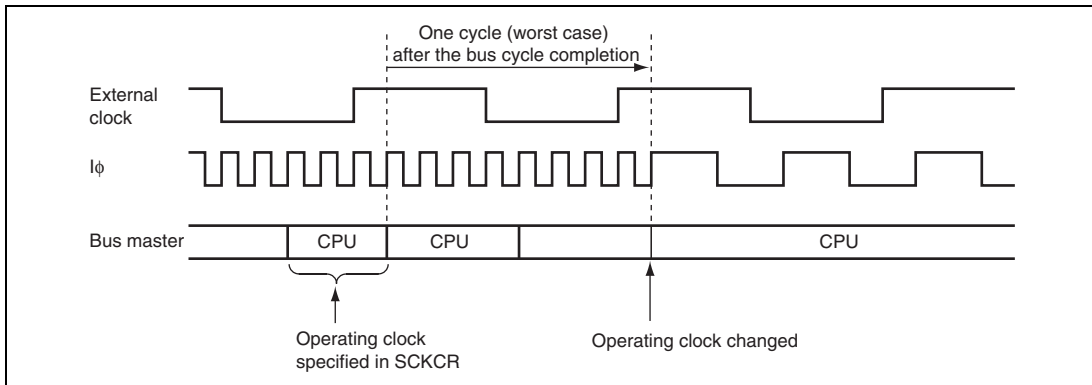

Figure 24.6 Clock Modification Timing

24.5.2 Notes on Resonator

Since various characteristics related to the resonator are closely linked to the user's board design, thorough evaluation is necessary on the user's part, using the resonator connection examples shown in this section as a reference. As the parameters for the resonator will depend on the floating capacitance of the resonator and the mounting circuit, the parameters should be determined in consultation with the resonator manufacturer. The design must ensure that a voltage exceeding the maximum rating is not applied to the resonator pin.

24.5.3 Notes on Board Design

When using the crystal resonator, place the crystal resonator and its load capacitors as close to the XTAL and EXTAL pins as possible. Other signal lines should be routed away from the oscillation circuit as shown in Figure 24.7 to prevent induction from interfering with correct oscillation.

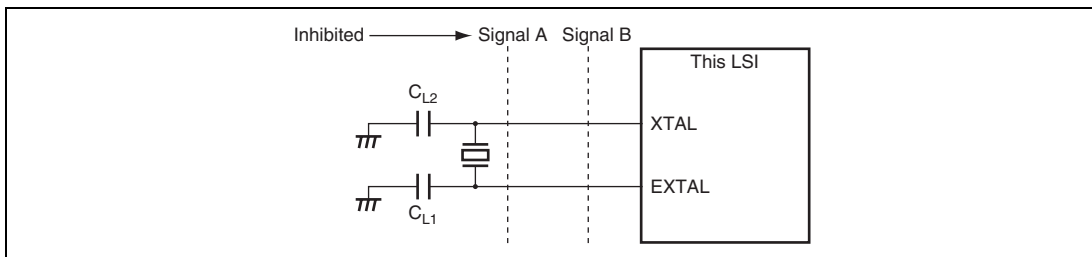

Figure 24.7 Note on Board Design for Oscillation Circuit

Figure 24.8 shows the external circuitry recommended for the PLL circuit. Separate PLLVcc and PLLVss from the other Vcc and Vss lines at the board power supply source, and be sure to insert bypass capacitors CPB and CB close to the pins.

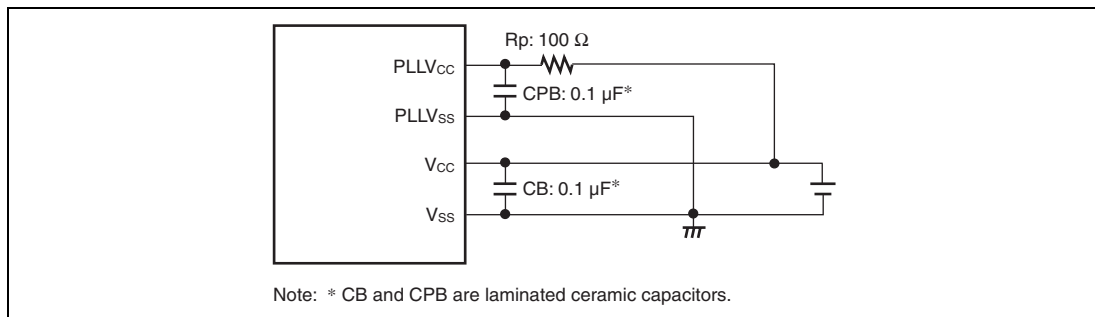

Figure 24.8 Recommended External Circuitry for PLL Circuit

Section 25 Power-Down Modes

Functions for reduced power consumption by this LSI include a multi-clock function, module stop function, and a function for transition to power-down mode.

25.1 Features

- Multi-clock function
The frequency division ratio is settable independently for the system clock, peripheral module clock, and external bus clock.
- Module stop function
The functions for each peripheral module can be stopped to make a transition to a power-down mode.
- Transition function to power-down mode
Transition to a power-down mode is possible to stop the CPU, peripheral modules, and oscillator.
- Five power-down modes
 - Sleep mode
 - All-module-clock-stop mode
 - Software standby mode
 - Deep software standby mode
 - Hardware standby mode

Table 25.1 shows conditions to shift to a power-down mode, states of the CPU and peripheral modules, and clearing method for each mode. After the reset state, since this LSI operates in normal program execution state, the modules, other than the DMAC and DTC, are stopped.

Table 25.1 States of Operation

State of Operation	Sleep Mode	All-Module-Clock-Stop Mode	Software Standby Mode	Deep Software Standby Mode	Hardware Standby Mode
Transition condition	Control register + instruction	Control register + instruction	Control register + instruction	Control register + instruction	Pin input
Cancellation method	Interrupt	Interrupt* ²	Interrupt* ⁸	Interrupt* ⁸	
Oscillator	Operating	Operating	Halted	Halted	Halted
CPU	Halted (retained)	Halted (retained)	Halted (retained)	Halted (undefined)	Halted (undefined)
On-chip RAMs 6 to 4 (H'FEE000 to H'FF3FFF)	Operating (retained)	Halted (retained)	Halted (retained)	Halted (undefined)	Halted (undefined)
On-chip RAMs 3 to 0 (H'FF4000 to H'FFBFFF)	Operating (retained)	Halted (retained)	Halted (retained)	Halted (retained/undefined)* ⁵	Halted (undefined)
Watchdog timer	Operating	Operating	Halted (retained)	Halted (undefined)	Halted (undefined)
8-bit timer (unit 0/1)	Operating	Operating* ⁴	Halted (retained)	Halted (undefined)	Halted (undefined)
Voltage detection circuit* ⁹	Operating	Operating	Operating	Operating	Halted
Power-on reset circuit * ⁹	Operating	Operating	Operating	Operating	Halted
Other peripheral modules	Operating	Halted* ¹	Halted* ¹	Halted* ⁷ (undefined)	Halted* ³ (undefined)
I/O ports	Operating	Retained	Retained* ⁶	Halted* ⁶ (undefined)	Hi-Z

Notes: "Halted (retained)" in the table means that the internal values are retained and internal operations are suspended.

"Halted (undefined)" in the table means that the internal values are undefined and the power supply for internal operations is turned off.

1. SCI enters the reset state, and other peripheral modules retain their states.
2. External interrupt and some internal interrupts (8-bit timer and watchdog timer).

3. All peripheral modules enter the reset state.
4. "Functioning" or "Halted" is selectable through the setting of bits MSTPA9 and MSTPA8 in MSTPCRA.
5. "Retained" or "Undefined" of the contents of RAM is selected by the setting of the bits RAMCUT2 to RAMCUT0 in DPSBYCR.
6. Retention or high-impedance for the address bus and bus-control signals ($\overline{CS0}$ to $\overline{CS7}$, \overline{AS} , \overline{RD} , \overline{HWR} , and \overline{LWR}) is selected by the setting of the OPE bit in SBYCR.
7. Some peripheral modules enter a state where the register values are retained.
8. External interrupt, voltage monitoring interrupt*⁹
9. Supported only by the H8SX/1638L Group.

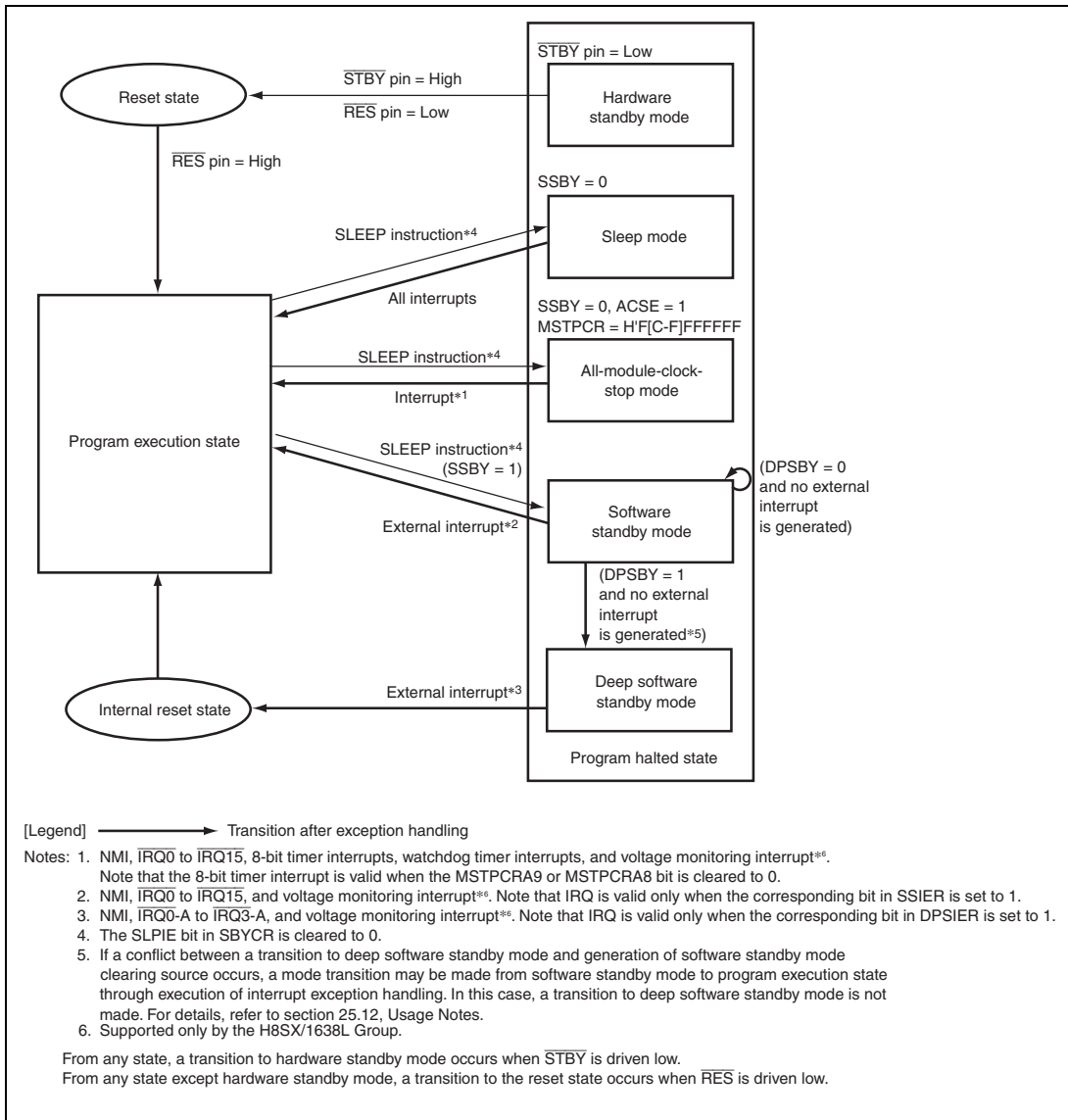

Figure 25.1 Mode Transitions

25.2 Register Descriptions

The registers related to the power-down modes are shown below. For details on the system clock control register (SCKCR), refer to section 24.1.1, System Clock Control Register (SCKCR).

- Standby control register (SBYCR)
- Module stop control register A (MSTPCRA)
- Module stop control register B (MSTPCRB)
- Module stop control register C (MSTPCRC)
- Deep standby control register (DPSBYCR)
- Deep standby wait control register (DPSWCR)
- Deep standby interrupt enable register (DPSIER)
- Deep standby interrupt flag register (DPSIFR)
- Deep standby interrupt edge register (DPSIEGR)
- Reset status register (RSTSR)
- Deep standby backup register (DPSBKRn) (n=15 to 0)

25.2.1 Standby Control Register (SBYCR)

SBYCR controls software standby mode.

Bit	15	14	13	12	11	10	9	8
Bit name	SSBY	OPE	—	STS4	STS3	STS2	STS1	STS0
Initial value:	0	1	0	0	1	1	1	1
R/W:	R/W	R/W	R/W	R/W	R/W	R/W	R/W	R/W
Bit	7	6	5	4	3	2	1	0
Bit name	SLPIE	—	—	—	—	—	—	—
Initial value:	0	0	0	0	0	0	0	0
R/W:	R/W	R/W	R/W	R/W	R/W	R/W	R/W	R/W

Bit	Bit Name	Initial Value	R/W	Description
15	SSBY	0	R/W	<p>Software Standby</p> <p>Specifies the transition mode after executing the SLEEP instruction</p> <p>0: Shifts to sleep mode after the SLEEP instruction is executed</p> <p>1: Shifts to software standby mode after the SLEEP instruction is executed</p> <p>This bit does not change when clearing the software standby mode by using interrupts and shifting to normal operation. For clearing, write 0 to this bit. When the WDT is used in watchdog timer mode, the setting of this bit is disabled. In this case, a transition is always made to sleep mode or all-module-clock-stop mode after the SLEEP instruction is executed. When the SLPIE bit is set to 1, this bit should be cleared to 0.</p>
14	OPE	1	R/W	<p>Output Port Enable</p> <p>Specifies whether the output of the address bus and bus control signals (CS0 to CS7, AS, RD, HWR, and LWR) is retained or these lines are set to the high-Z state in software standby mode or deep software standby mode.</p> <p>0: In software standby mode or deep software standby mode, address bus and bus control signal lines are high-impedance.</p> <p>1: In software standby mode or deep software standby mode, output states of address bus and bus control signals are retained.</p>
13	—	0	R/W	<p>Reserved</p> <p>This bit is always read as 0. The write value should always be 0.</p>

Bit	Bit Name	Initial Value	R/W	Description
12	STS4	0	R/W	Standby Timer Select 4 to 0
11	STS3	1	R/W	<p>These bits select the time the MCU waits for the clock to settle when software standby mode is cleared by an interrupt. With a crystal resonator, refer to table 25.2 and make a selection according to the operating frequency so that the standby time is at least equal to the oscillation settling time. With an external clock, a PLL circuit settling time is necessary. Refer to table 25.2 to set the standby time.</p> <p>While oscillation is being settled, the timer is counted on the Pϕ clock frequency. Careful consideration is required in multi-clock mode.</p> <p>00000: Reserved 00001: Reserved 00010: Reserved 00011: Reserved 00100: Reserved 00101: Standby time = 64 states 00110: Standby time = 512 states 00111: Standby time = 1024 states 01000: Standby time = 2048 states 01001: Standby time = 4096 states 01010: Standby time = 16384 states 01011: Standby time = 32768 states 01100: Standby time = 65536 states 01101: Standby time = 131072 states 01110: Standby time = 262144 states 01111: Standby time = 524288 states 1xxxx: Reserved</p>
10	STS2	1	R/W	
9	STS1	1	R/W	
8	STS0	1	R/W	

Bit	Bit Name	Initial Value	R/W	Description
7	SLPIE	0	R/W	<p>Sleep Instruction Exception Handling Enable</p> <p>Selects whether a sleep interrupt is generated or a transition to power-down mode is made when a SLEEP instruction is executed.</p> <p>0: A transition to power-down mode is made when a SLEEP instruction is executed.</p> <p>1: A sleep instruction exception handling is generated when a SLEEP instruction is executed.</p> <p>Even after a sleep instruction exception handling is executed, this bit remains set to 1. For clearing, write 0 to this bit.</p>
6 to 0	—	All 0	R/W	<p>Reserved</p> <p>These bits are always read as 0. The write value should always be 0.</p>

Notes: 1. x: Don't care
 2. With the F-ZTAT version, the flash memory settling time must be reserved.

25.2.2 Module Stop Control Registers A and B (MSTPCRA and MSTPCRB)

MSTPCRA and MSTPCRB control module stop state. Setting a bit to 1 makes the corresponding module enter module stop state, while clearing the bit to 0 clears module stop state.

• MSTPCRA

Bit	15	14	13	12	11	10	9	8
Bit name	ACSE	MSTPA14	MSTPA13	MSTPA12	MSTPA11	MSTPA10	MSTPA9	MSTPA8
Initial value:	0	0	0	0	1	1	1	1
R/W:	R/W	R/W	R/W	R/W	R/W	R/W	R/W	R/W

Bit	7	6	5	4	3	2	1	0
Bit name	MSTPA7	MSTPA6	MSTPA5	MSTPA4	MSTPA3	MSTPA2	MSTPA1	MSTPA0
Initial value:	1	1	1	1	1	1	1	1
R/W:	R/W	R/W	R/W	R/W	R/W	R/W	R/W	R/W

- MSTPCRB

Bit	15	14	13	12	11	10	9	8
Bit name	MSTPB15	MSTPB14	MSTPB13	MSTPB12	MSTPB11	MSTPB10	MSTPB9	MSTPB8
Initial value:	1	1	1	1	1	1	1	1
R/W:	R/W	R/W	R/W	R/W	R/W	R/W	R/W	R/W

Bit	7	6	5	4	3	2	1	0
Bit name	MSTPB7	MSTPB6	MSTPB5	MSTPB4	MSTPB3	MSTPB2	MSTPB1	MSTPB0
Initial value:	1	1	1	1	1	1	1	1
R/W:	R/W	R/W	R/W	R/W	R/W	R/W	R/W	R/W

- MSTPCRA

Bit	Bit Name	Initial Value	R/W	Module
15	ACSE	0	R/W	All-Module-Clock-Stop Mode Enable Enables/disables all-module-clock-stop state for reducing current consumption by stopping the bus controller and I/O ports operations when the CPU executes the SLEEP instruction after module stop state has been set for all the on-chip peripheral modules controlled by MSTPCR. 0: All-module-clock-stop mode disabled 1: All-module-clock-stop mode enabled
14	MSTPA14	0	R/W	Reserved
13	MSTPA13	0	R/W	DMA controller (DMAC)
12	MSTPA12	0	R/W	Data transfer controller (DTC)
11	MSTPA11	1	R/W	Reserved
10	MSTPA10	1	R/W	These bits are always read as 1. The write value should always be 1.
9	MSTPA9	1	R/W	8-bit timer (TMR_3 and TMR_2)
8	MSTPA8	1	R/W	8-bit timer (TMR_1 and TMR_0)
7	MSTPA7	1	R/W	Reserved
6	MSTPA6	1	R/W	These bits are always read as 1. The write value should always be 1.

Bit	Bit Name	Initial Value	R/W	Module
5	MSTPA5	1	R/W	D/A converter (channels 1 and 0)
4	MSTPA4	1	R/W	Reserved This bit is always read as 1. The write value should always be 1.
3	MSTPA3	1	R/W	A/D converter (unit 0)
2	MSTPA2	1	R/W	Reserved This bit is always read as 1. The write value should always be 1.
1	MSTPA1	1	R/W	16-bit timer pulse unit (TPU channels 11 to 6)
0	MSTPA0	1	R/W	16-bit timer pulse unit (TPU channels 5 to 0)

- MSTPCRB

Bit	Bit Name	Initial Value	R/W	Module
15	MSTPB15	1	R/W	Programmable pulse generator (PPG_0: PO15 to PO0)
14	MSTPB14	1	R/W	Reserved
13	MSTPB13	1	R/W	These bits are always read as 1. The write value should always be 1.
12	MSTPB12	1	R/W	Serial communications interface_4 (SCI_4)
11	MSTPB11	1	R/W	Serial communications interface_3 (SCI_3)
10	MSTPB10	1	R/W	Serial communications interface_2 (SCI_2)
9	MSTPB9	1	R/W	Serial communications interface_1 (SCI_1)
8	MSTPB8	1	R/W	Serial communications interface_0 (SCI_0)
7	MSTPB7	1	R/W	I ² C bus interface 2_1 (IIC2_1)
6	MSTPB6	1	R/W	I ² C bus interface 2_0 (IIC2_0)
5	MSTPB5	1	R/W	User break controller (UBC)
4	MSTPB4	1	R/W	Reserved
3	MSTPB3	1	R/W	These bits are always read as 1. The write value should always be 1.
2	MSTPB2	1	R/W	
1	MSTPB1	1	R/W	
0	MSTPB0	1	R/W	

25.2.3 Module Stop Control Register C (MSTPCRC)

When bits MSTPC7 to MSTPC0 are set to 1, the corresponding on-chip RAM stops. Do not set the corresponding MSTPC7 to MSTPC0 bits to 1 while accessing the on-chip RAM. Do not access the on-chip RAM while bits MSTPC7 to MSTPC0 are set to 1.

The serial communications interfaces, 8-bit timers, CRC calculator, A/D converter, and programmable pulse generator (PPG: PO31 to PO16) are placed in the module stop state by using the MSTPC15 and MSTPC14, MSTPC13 and MSTPC12, MSTPC10, MSTPC9, and MSTPC8 bits, respectively.

Bit	15	14	13	12	11	10	9	8
Bit name	MSTPC15	MSTPC14	MSTPC13	MSTPC12	—	MSTPC10	MSTPC9	MSTPC8
Initial value:	1	1	1	1	1	1	1	1
R/W:	R/W	R/W	R/W	R/W	R/W	R/W	R/W	R/W
Bit	7	6	5	4	3	2	1	0
Bit name	MSTPC7	MSTPC6	MSTPC5	MSTPC4	MSTPC3	MSTPC2	MSTPC1	MSTPC0
Initial value:	0	0	0	0	0	0	0	0
R/W:	R/W	R/W	R/W	R/W	R/W	R/W	R/W	R/W

Bit	Bit Name	Initial Value	R/W	Module
15	MSTPC15	1	R/W	Serial communications interface_5 (SCI_5), (IrDA)
14	MSTPC14	1	R/W	Serial communications interface_6 (SCI_6)
13	MSTPC13	1	R/W	8-bit timer (TMR_4, TMR_5)
12	MSTPC12	1	R/W	8-bit timer (TMR_6, TMR_7)
11	—	0	R/W	Reserved This bit is always read as 1. The write value should always be 1.
10	MSTPC10	1	R/W	Cyclic redundancy check calculator
9	MSTPC9	1	R/W	A/D converter (unit 1)
8	MSTPC8	1	R/W	Programmable pulse generator (PPG_1: PO31 to PO16)

Bit	Bit Name	Initial Value	R/W	Module
7	MSTPC7	0	R/W	With 56 Kbytes of on-chip RAM:
6	MSTPC6	0	R/W	On-chip RAM 6 (H'FEE000 to H'FEFFFF) With 40 Kbytes of on-chip RAM: Reserved Always set the MSTPC7 and MSTPC6 bits to the same value.
5	MSTPC5	0	R/W	With 56 Kbytes of on-chip RAM:
4	MSTPC4	0	R/W	On-chip RAM 5, 4 (H'FF0000 to H'FF3FFF) With 40 Kbytes of on-chip RAM: On-chip RAM 4 (H'FF2000 to H'FF3FFF) Always set the MSTPC5 and MSTPC4 bits to the same value.
3	MSTPC3	0	R/W	On-chip RAM_3, 2 (H'FF4000 to H'FF7FFF)
2	MSTPC2	0	R/W	Always set the MSTPC3 and MSTPC2 bits to the same value.
1	MSTPC1	0	R/W	On-chip RAM_1, 0 (H'FF8000 to H'FFBFFF)
0	MSTPC0	0	R/W	Always set the MSTPC1 and MSTPC0 bits to the same value.

25.2.4 Deep Standby Control Register (DPSBYCR)

DPSBYCR controls deep software standby mode.

DPSBYCR is not initialized by the internal reset signal upon exit from deep software standby mode.

Bit	7	6	5	4	3	2	1	0
Bit name	DPSBY	IOKEEP	RAMCUT2	RAMCUT1	—	—	—	RAMCUT0
Initial value:	0	0	0	0	0	0	0	1
R/W:	R/W	R/W	R/W	R/W	R/W	R/W	R/W	R/W

Bit	Bit Name	Initial Value	R/W	Module
7	DPSBY	0	R/W	Deep Software Standby
				When the SSBY bit in SBYCR has been set to 1, executing the SLEEP instruction causes a transition to software standby mode. At this time, if there is no source to clear software standby mode and this bit is set to 1, a transition to deep software standby mode is made.
				SSBY DPSBY Entry to
				<hr/>
				0 x Enters sleep mode after execution of a SLEEP instruction.
				<hr/>
				1 0 Enters software standby mode after execution of a SLEEP instruction.
				<hr/>
				1 1 Enters deep software standby mode after execution of a SLEEP instruction.
				<hr/>

When deep software standby mode is canceled due to an interrupt, this bit remains at 1. Write a 0 here to clear it. Setting of this bit has no effect when the WDT is used in watchdog timer mode. In this case, executing the SLEEP instruction always initiates entry to sleep mode or all-module-clock-stop mode. Be sure to clear this bit to 0 when setting the SLPIE bit to 1.

Bit	Bit Name	Initial Value	R/W	Module						
6	IOKEEP	0	R/W	I/O Port Retention In deep software standby mode, the ports retain the states that were held in software standby mode. This bit specifies whether or not the state that has been held in deep software standby mode is retained after exit from deep software standby mode. <table border="1"> <thead> <tr> <th>IOKEEP</th> <th>Pin State</th> </tr> </thead> <tbody> <tr> <td>0</td> <td>The retained port states are released simultaneously with exit from deep software standby mode.</td> </tr> <tr> <td>1</td> <td>The retained port states are released when a 0 is written to this bit following exit from deep software standby mode.</td> </tr> </tbody> </table>	IOKEEP	Pin State	0	The retained port states are released simultaneously with exit from deep software standby mode.	1	The retained port states are released when a 0 is written to this bit following exit from deep software standby mode.
IOKEEP	Pin State									
0	The retained port states are released simultaneously with exit from deep software standby mode.									
1	The retained port states are released when a 0 is written to this bit following exit from deep software standby mode.									
5	RAMCUT2	0	R/W	On-chip RAM Power Off 2 RAMCUT 2 to 0 control the internal power supply to the on-chip RAM in deep software standby mode. For details, see descriptions of the RAMCUT0 bit.						
4	RAMCUT1	0	R/W	On-chip RAM Power Off 1 RAMCUT 2 to 0 control the internal power supply to the on-chip RAM in deep software standby mode. For details, see descriptions of the RAMCUT0 bit.						
3 to 1	—	All 0	R/W	Reserved These bits are always read as 0. The write value should always be 0.						
0	RAMCUT0	1	R/W	On-chip RAM Power Off 0 RAMCUT 2 to 0 control the internal power supply to the on-chip RAM in deep software standby mode. RAMCUT 2 to 0 000: Power is supplied to the on-chip RAM. 111: Power is not supplied to the on-chip RAM. Settings other than above are prohibited.						

25.2.5 Deep Standby Wait Control Register (DPSWCR)

DPSWCR selects the time for which the MCU waits until the clock settles when deep software standby mode is canceled by an interrupt.

DPSWCR is not initialized by the internal reset signal upon exit from deep software standby mode.

Bit	7	6	5	4	3	2	1	0
Bit name	—	—	WTSTS5	WTSTS4	WTSTS3	WTSTS2	WTSTS1	WTSTS0
Initial value:	0	0	0	0	0	0	0	0
R/W:	R/W	R/W	R/W	R/W	R/W	R/W	R/W	R/W

Bit	Bit Name	Initial Value	R/W	Module
7, 6	—	All 0	R/W	Reserved
These bits are always read as 0. The write value should always be 0.				

Bit	Bit Name	Initial Value	R/W	Module
5 to 0	WTSTS [5:0]	0	R/W	<p>Deep Software Standby Wait Time Setting</p> <p>These bits select the time for which the MCU waits until the clock settles when deep software standby mode is canceled by an interrupt.</p> <p>When using a crystal resonator, see table 25.3 and select the wait time greater than the oscillation settling time for each operating frequency. When using an external clock, settling time for the PLL circuit should be considered. See table 25.3 to select the wait time.</p> <p>During the oscillation settling period, counting is performed with the clock frequency input to the EXTAL.</p> <p>000000: Reserved</p> <p>000001: Reserved</p> <p>000010: Reserved</p> <p>000011: Reserved</p> <p>000100: Reserved</p> <p>000101: Wait time = 64 states</p> <p>000110: Wait time = 512 states</p> <p>000111: Wait time = 1024 states</p> <p>001000: Wait time = 2048 states</p> <p>001001: Wait time = 4096 states</p> <p>001010: Wait time = 16384 states</p> <p>001011: Wait time = 32768 states</p> <p>001100: Wait time = 65536 states</p> <p>001101: Wait time = 131072 states</p> <p>001110: Wait time = 262144 states</p> <p>001111: Wait time = 524288 states</p> <p>01xxxx: Reserved</p>

25.2.6 Deep Standby Interrupt Enable Register (DPSIER)

DPSIER enables or disables interrupts to clear deep software standby mode.

DPSIER is not initialized by the internal reset signal upon exit from deep software standby mode.

Bit	7	6	5	4	3	2	1	0
Bit name	—	—	—	DLVDIE*	DIRQ3E	DIRQ2E	DIRQ1E	DIRQ0E
Initial value:	0	0	0	0	0	0	0	0
R/W:	R/W	R/W	R/W	R/W	R/W	R/W	R/W	R/W

Note: * Supported only by the H8SX/1638L Group

Bit	Bit Name	Initial Value	R/W	Module
7	—	0	R/W	Reserved This bit is always read as 0. The write value should always be 0.
6 to 5	—	All 0	R/W	Reserved These bits are always read as 0. The write value should always be 0.
4	DLVDIE*	0	R/W	LVD Interrupt Enable Enables/disables exit from deep software standby mode by the voltage monitoring interrupt signal. 0: Disables exit from deep software standby mode by the voltage monitoring interrupt signal. 1: Enables exit from deep software standby mode by the voltage monitoring interrupt signal.
3	DIRQ3E	0	R/W	IRQ3 Interrupt Enable Enables or disables exit from deep software standby mode by IRQ3-A. 0: Disables exit from deep software standby mode by IRQ3-A. 1: Enables exit from deep software standby mode by IRQ3-A.

Bit	Bit Name	Initial Value	R/W	Module
2	DIRQ2E	0	R/W	IRQ2 Interrupt Enable Enables or disables exit from deep software standby mode by IRQ2-A. 0: Disables exit from deep software standby mode by IRQ2-A 1: Enables exit from deep software standby mode by IRQ2-A
1	DIRQ1E	0	R/W	IRQ1 Interrupt Enable Enables or disables exit from deep software standby mode by IRQ1-A. 0: Disables exit from deep software standby mode by IRQ1-A. 1: Enables exit from deep software standby mode by IRQ1-A.
0	DIRQ0E	0	R/W	IRQ0 Interrupt Enable Enables or disables exit from deep software standby mode by IRQ0-A. 0: Disables exit from deep software standby mode by IRQ0-A. 1: Enables exit from deep software standby mode by IRQ0-A.

Note: * Supported only by the H8SX/1638L Group.

25.2.7 Deep Standby Interrupt Flag Register (DPSIFR)

DPSIFR is used to request an exit from deep software standby mode. When the interrupt specified in DPSIEGR is generated, the applicable bit in DPSIFR is set to 1. The bit is set to 1 even when an interrupt is generated in the modes other than deep software standby. Therefore, a transition to deep software standby should be made after this register bits are cleared to 0.

DPSIFR is not initialized by the internal reset signal upon exit from deep software standby mode.

Bit	7	6	5	4	3	2	1	0
Bit name	DNMIF	—	—	DLVDIF*2	DIRQ3F	DIRQ2F	DIRQ1F	DIRQ0F
Initial value:	0	0	0	0	0	0	0	0
R/W:	R/(W)*1	R	R	R/(W)*1	R/(W)*1	R/(W)*1	R/(W)*1	R/(W)*1

Notes: 1. Only 0 can be written to clear the flag.
2. Supported only by the H8SX/1638L Group.

Bit	Bit Name	Initial Value	R/W	Module
7	DNMIF	0	R/(W)*1	NMI Flag [Setting condition] NMI input specified in DPSIEGR is generated. [Clearing condition] Writing a 0 to this bit after reading it as 1.
6 to 5	—	All 0	R/W	Reserved These bits are always read as 0. The write value should always be 0.
4	DLVDIF*3	0	R/(W)*1	LVD Interrupt Flag [Setting condition] Voltage monitoring interrupt is generated. [Clearing condition] Writing a 0 to this bit after reading it as 1.

Bit	Bit Name	Initial Value	R/W	Module
3	DIRQ3F	0	R/(W)* ¹	IRQ3 Interrupt Flag [Setting condition] IRQ3-A input specified in DPSIEGR is generated. [Clearing condition] Writing a 0 to this bit after reading it as 1.
2	DIRQ2F	0	R/(W)* ¹	IRQ2-A Interrupt Flag [Setting condition] IRQ2 input specified in DPSIEGR is generated. [Clearing condition] Writing a 0 to this bit after reading it as 1.
1	DIRQ1F	0	R/(W)* ¹	IRQ1 Interrupt Flag [Setting condition] IRQ1-A input specified in DPSIEGR is generated. [Clearing condition] Writing a 0 to this bit after reading it as 1.
0	DIRQ0F	0	R/(W)* ¹	IRQ0-A Interrupt Flag [Setting condition] IRQ0 input specified in DPSIEGR is generated. [Clearing condition] Writing a 0 to this bit after reading it as 1.

- Notes: 1. Only 0 can be written to clear the flag.
 2. Supported only by the H8SX/1638L Group.

25.2.8 Deep Standby Interrupt Edge Register (DPSIEGR)

DPSIEGR selects the rising or falling edge to clear deep software standby mode.

DPSIEGR is not initialized by the internal reset signal upon exit from deep software standby mode.

Bit	7	6	5	4	3	2	1	0
Bit name	DNMIEG	—	—	—	DIRQ3EG	DIRQ2EG	DIRQ1EG	DIRQ0EG
Initial value:	0	0	0	0	0	0	0	0
R/W:	R/W	R/W	R/W	R/W	R/W	R/W	R/W	R/W

Bit	Bit Name	Initial Value	R/W	Module
7	DNMIEG	0	R/W	NMI Edge Select Selects the active edge for NMI pin input. 0: The interrupt request is generated by a falling edge. 1: The interrupt request is generated by a rising edge.
6 to 4	—	All 0	R/W	Reserved These bits are always read as 0. The write value should always be 0.
3	DIRQ3EG	0	R/W	IRQ3-A Interrupt Edge Select Selects the active edge for IRQ3 pin input. 0: The interrupt request is generated by a falling edge. 1: The interrupt request is generated by a rising edge.
2	DIRQ2EG	0	R/W	IRQ2-A Interrupt Edge Select Selects the active edge for IRQ2 pin input. 0: The interrupt request is generated by a falling edge. 1: The interrupt request is generated by a rising edge.

Bit	Bit Name	Initial Value	R/W	Module
1	DIRQ1EG	0	R/W	IRQ1-A Interrupt Edge Select Selects the active edge for IRQ1 pin input. 0: The interrupt request is generated by a falling edge. 1: The interrupt request is generated by a rising edge.
0	DIRQ0EG	0	R/W	IRQ0-A Interrupt Edge Select Selects the active edge for IRQ0 pin input. 0: The interrupt request is generated by a falling edge. 1: The interrupt request is generated by a rising edge.

25.2.9 Reset Status Register (RSTSR)

The DPSRSTF bit in RSTSR indicates that deep software standby mode has been canceled by an interrupt.

RSTSR is not initialized by the internal reset signal upon exit from deep software standby mode.

Bit	7	6	5	4	3	2	1	0
Bit name	DPSRSTF	—	—	—	—	LVDF*2	—	PORF*2
Initial value:	0	0	0	0	0	0*3	0*3	0*3
R/W:	R/(W)*1	R/W	R/W	R/W	R/W	R/(W)*4	R/W	R/W*5

- Notes:
1. Only 0 can be written to clear the flag.
 2. Supported only by the H8SX/1638L Group.
 3. Initial value is undefined in the H8SX/1638L Group.
 4. Only 0 can be written to clear the flag in the H8SX/1638L Group.
 5. Readable only in the H8SX/1638L Group.

Bit	Bit Name	Initial Value	R/W	Module
7	DPSRSTF	0	R/(W)*	<p>Deep Software Standby Reset Flag</p> <p>Indicates that deep software standby mode has been canceled by an external interrupt source specified in DPSIER or DPSIEGR and an internal reset is generated.</p> <p>[Setting condition]</p> <p>Deep software standby mode is canceled by an external interrupt source.</p> <p>[Clearing condition]</p> <p>Writing a 0 to this bit after reading it as 1.</p>
6 to 3	—	All 0	R/W	<p>Reserved</p> <p>These bits are always read as 0. The write value should always be 0.</p>

- H8SX/1638 Group

Bit	Bit Name	Initial Value	R/W	Module
2 o 0	—	All 0	R/W	<p>Reserved</p> <p>These bits are always read as 0. The write value should always be 0.</p>

- H8SX/1638L Group

Bit	Bit Name	Initial Value	R/W	Module
2	LVDF	Undefined	R/(W)*	<p>LVD Flag</p> <p>This bit indicates that the voltage-detection circuit has detected a low voltage (Vcc at or below Vdet).</p> <p>For details, see section 5, Voltage Detection Circuit (LVD).</p>
1	—	Undefined	R/W	<p>Reserved</p> <p>The write value should always be 0.</p>
0	PORF	Undefined	R	<p>Power-on Reset Flag</p> <p>This bit indicates that a power-on reset has been generated.</p> <p>For details, see section 4, Resets.</p>

Note: * Only 0 can be written to clear the flag.

25.2.10 Deep Standby Backup Register (DPSBKRn)

DPSBKRn (n = 15 to 0) is a 16-bit readable/writable register to store data during deep software standby mode.

Although data in on-chip RAM is not retained in deep software standby mode, data in this register is retained.

DPSBKRn is not initialized by the internal reset signal upon exit from deep software standby mode.

Bit	7	6	5	4	3	2	1	0
Bit name	BKUPn7	BKUPn6	BKUPn5	BKUPn4	BKUPn3	BKUPn2	BKUPn1	BKUPn0
Initial value:	0	0	0	0	0	0	0	0
R/W:	R/W	R/W	R/W	R/W	R/W	R/W	R/W	R/W

n: 15 to 0

25.3 Multi-Clock Function

When bits ICK2 to ICK0, PCK2 to PCK0, and BCK2 to BCK0 in SCKCR are set, the clock frequency is changed at the end of the bus cycle. The CPU and bus masters operate on the operating clock specified by bits ICK2 to ICK0. The peripheral modules operate on the operating clock specified by bits PCK2 to PCK0. The external bus operates on the operating clock specified by bits BCK2 to BCK0.

Even if the frequencies specified by bits PCK2 to PCK0 and BCK2 to BCK0 are higher than the frequency specified by bits ICK2 to ICK0, the specified values are not reflected in the peripheral module and external bus clocks. The peripheral module and external bus clocks are restricted to the operating clock specified by bits ICK2 to ICK0.

25.4 Module Stop State

Module stop functionality can be set for individual on-chip peripheral modules.

When the corresponding MSTP bit in MSTPCRA, MSTPCRB, or MSTPCRC is set to 1, module operation stops at the end of the bus cycle and a transition is made to a module stop state. The CPU continues operating independently.

When the corresponding MSTP bit is cleared to 0, a module stop state is cleared and the module starts operating at the end of the bus cycle. In a module stop state, the internal states of modules other than the SCI are retained.

After the reset state is cleared, all modules other than the DMAC, DTC, and on-chip RAM are placed in a module stop state.

The registers of the module for which the module stop state is selected cannot be read from or written to.

25.5 Sleep Mode

25.5.1 Entry to Sleep Mode

When the SLEEP instruction is executed when the SSBY bit in SBYCR is 0, the CPU enters sleep mode. In sleep mode, CPU operation stops but the contents of the CPU's internal registers are retained. Other peripheral functions do not stop.

25.5.2 Exit from Sleep Mode

Sleep mode is exited by any interrupt, signals on the $\overline{\text{RES}}$ or $\overline{\text{STBY}}$ pin, a reset caused by a watchdog timer overflow, a voltage monitoring reset*, or a power-on reset*.

- Exit from sleep mode by interrupt
When an interrupt occurs, sleep mode is exited and interrupt exception processing starts. Sleep mode is not exited if the interrupt is disabled, or interrupts other than NMI are masked by the CPU.
- Exit from sleep mode by $\overline{\text{RES}}$ pin
Setting the $\overline{\text{RES}}$ pin level low selects the reset state. After the stipulated reset input duration, driving the $\overline{\text{RES}}$ pin high makes the CPU start the reset exception processing.
- Exit from sleep mode by $\overline{\text{STBY}}$ pin
When the $\overline{\text{STBY}}$ pin level is driven low, a transition is made to hardware standby mode.
- Exit from sleep mode by reset caused by watchdog timer overflow
Sleep mode is exited by an internal reset caused by a watchdog timer overflow.
- Exit from voltage monitoring reset*
Sleep mode is exited by a voltage monitoring reset of the voltage detection circuit.
- Exit from power-on reset*
Sleep mode is exited by a power-on reset.

Note: * Supported only by the H8SX/1638L Group.

25.6 All-Module-Clock-Stop Mode

When the ACSE bit is set to 1 and all modules controlled by MSTPCRA and MSTPCRB are stopped (MSTPCRA, MSTPCRB = H'FFFFFFF), or all modules except for the 8-bit timer (units 0 and 1) are stopped (MSTPCRA, MSTPCRB = H'F[C to F]FFFFFF), executing a SLEEP instruction with the SSBY bit in SBYCR cleared to 0 will cause all modules (except for the 8-bit timer*, watchdog timer, power-on reset circuit*², and voltage detection circuit*²), the bus controller, and the I/O ports to stop operating, and to make a transition to all-module-clock-stop mode at the end of the bus cycle.

When power consumption should be reduced ever more in all-module-clock-stop mode, stop modules controlled by MSTPCRC (MSTPCRC[15:8] = H'FFFF).

All-module-clock-stop mode is cleared by an external interrupt (NMI or $\overline{\text{IRQ0}}$ to $\overline{\text{IRQ15}}$ pins), $\overline{\text{RES}}$ pin input, or an internal interrupt (8-bit timer*¹, watchdog timer, or voltage-detection circuit*²), and the CPU returns to the normal program execution state via the exception handling state. All-module-clock-stop mode is not cleared if interrupts are disabled, if interrupts other than NMI are masked on the CPU side, or if the relevant interrupt is designated as a DTC activation source.

When the $\overline{\text{STBY}}$ pin is driven low, a transition is made to hardware standby mode.

- Notes:
1. Operation or halting of the 8-bit timer can be selected by bits MSTPA9 and MSTPA8 in MSTPCRA.
 2. Supported only by the H8SX/1638L Group.

25.7 Software Standby Mode

25.7.1 Entry to Software Standby Mode

If a SLEEP instruction is executed when the SSBY bit in SBYCR is set to 1 and the DPSBY bit in DPSBYCR is cleared to 0, software standby mode is entered. In this mode, the CPU, on-chip peripheral functions, and oscillator all stop. However, the contents of the CPU's internal registers, on-chip RAM data, and the states of on-chip peripheral functions other than the SCI, and the states of the I/O ports, are retained. Whether the address bus and bus control signals are placed in the high-impedance state or retain the output state can be specified by the OPE bit in SBYCR. In this mode the oscillator stops, allowing power consumption to be significantly reduced.

If the WDT is used in watchdog timer mode, it is impossible to make a transition to software standby mode. The WDT should be stopped before the SLEEP instruction execution.

25.7.2 Exit from Software Standby Mode

Software standby mode is cleared by an external interrupt (NMI, or $\overline{\text{IRQ0}}$ to $\overline{\text{IRQ15}}^{*1}$), an internal interrupt (a voltage monitoring interrupt^{*2}), a voltage monitoring reset^{*2}, a power-on reset^{*2} or by means of the $\overline{\text{RES}}$ pin or $\overline{\text{STBY}}$ pin.

1. Exit from software standby mode by interrupt

When an NMI, or IRQ0 to IRQ15^{*1} interrupt request signal is input, clock oscillation starts, and after the elapse of the time set in bits STS4 to STS0 in SBYCR, stable clocks are supplied to the entire LSI, software standby mode is cleared, and interrupt exception handling is started.

When clearing software standby mode with an IRQ0 to IRQ15^{*1} interrupt, set the corresponding enable bit to 1 and ensure that no interrupt with a higher priority than interrupts IRQ0 to IRQ15^{*1} is generated. Software standby mode cannot be cleared if the interrupt has been masked on the CPU side or has been designated as a DTC activation source.

2. Exit from voltage monitoring reset^{*2}

When a voltage monitoring reset is generated by the fall of power-voltage, software standby mode is cleared and a clock oscillation starts. At the same time, a clock signal is supplied throughout the LSI. After that, if power voltage rises, the voltage detection reset is released. Thereafter, CPU starts the reset exception handling.

3. Exit from power-on reset*²

When a power-on reset is generated by the fall of power voltage, software standby mode is released. After that, if power voltage rises, the clock oscillation starts and the power-on reset is released while the clock oscillation stabilization time is well kept. Thereafter CPU starts the reset exception handling.

4. Exit from software standby mode by $\overline{\text{RES}}$ pin

When the $\overline{\text{RES}}$ pin is driven low, clock oscillation is started. At the same time as clock oscillation starts, clocks are supplied to the entire LSI. Note that the $\overline{\text{RES}}$ pin must be held low until clock oscillation settles. When the $\overline{\text{RES}}$ pin goes high, the CPU begins reset exception handling.

5. Exit from software standby mode by $\overline{\text{STBY}}$ pin

When the $\overline{\text{STBY}}$ pin is driven low, a transition is made to hardware standby mode.

- Notes: 1. By setting the SSIn bit in SSIER to 1, $\overline{\text{IRQ0}}$ to $\overline{\text{IRQ15}}$ can be used as a software standby mode clearing source.
2. Supported only by the H8SX/1638L Group.

25.7.3 Setting Oscillation Settling Time after Exit from Software Standby Mode

Bits STS4 to STS0 in SBYCR should be set as described below.

1. Using a crystal resonator

Set bits STS4 to STS0 so that the standby time is at least equal to the oscillation settling time. Table 25.2 shows the standby times for operating frequencies and settings of bits STS4 to STS0.

2. Using an external clock

A PLL circuit settling time is necessary. Refer to table 25.2 to set the standby time.

Table 25.2 Oscillation Settling Time Setting

STS4	STS3	STS2	STS1	STS0	Standby Time	P ϕ * (MHz)						Unit
						35	25	20	13	10	8	
0	0	0	0	0	Reserved	—	—	—	—	—	—	μ s
				1	Reserved	—	—	—	—	—	—	
			1	0	Reserved	—	—	—	—	—	—	
			1	1	Reserved	—	—	—	—	—	—	
	1	0	0	0	Reserved	—	—	—	—	—	—	
				1	64	1.8	2.6	3.2	4.9	6.4	8.0	
			1	0	512	14.6	20.5	25.6	39.4	51.2	64.0	
				1	1024	29.3	41.0	51.2	78.8	102.4	128.0	
1	0	0	0	0	2048	58.5	81.9	102.4	157.5	204.8	256.0	
				1	4096	0.12	0.16	0.20	0.32	0.41	0.51	ms
			1	0	16384	0.47	0.66	0.82	1.26	1.64	2.05	
				1	32768	0.94	1.31	1.64	2.52	3.28	4.10	
	1	0	0	0	65536	1.87	2.62	3.28	5.04	6.55	8.19	
				1	131072	3.74	5.24	6.55	10.08	13.11	16.38	
			1	0	262144	7.49	10.49	13.11	20.16	26.21	32.77	
				1	524288	14.98	20.97	26.21	40.33	52.43	65.54	
1	0	0	0	0	Reserved	—	—	—	—	—	—	

[Legend]

 : Recommended setting when external clock is in use

 : Recommended setting when crystal oscillator is in use

Note: * P ϕ is the output from the peripheral module frequency divider. The oscillation settling time, which includes a period where the oscillation by an oscillator is not stable, depends on the resonator characteristics. The above figures are for reference.

25.7.4 Software Standby Mode Application Example

Figure 25.2 shows an example in which a transition is made to software standby mode at the falling edge on the NMI pin, and software standby mode is cleared at the rising edge on the NMI pin.

In this example, an NMI interrupt is accepted with the NMIEG bit in INTCR cleared to 0 (falling edge specification), then the NMIEG bit is set to 1 (rising edge specification), the SSBY bit is set to 1, and a SLEEP instruction is executed, causing a transition to software standby mode.

Software standby mode is then cleared at the rising edge on the NMI pin.

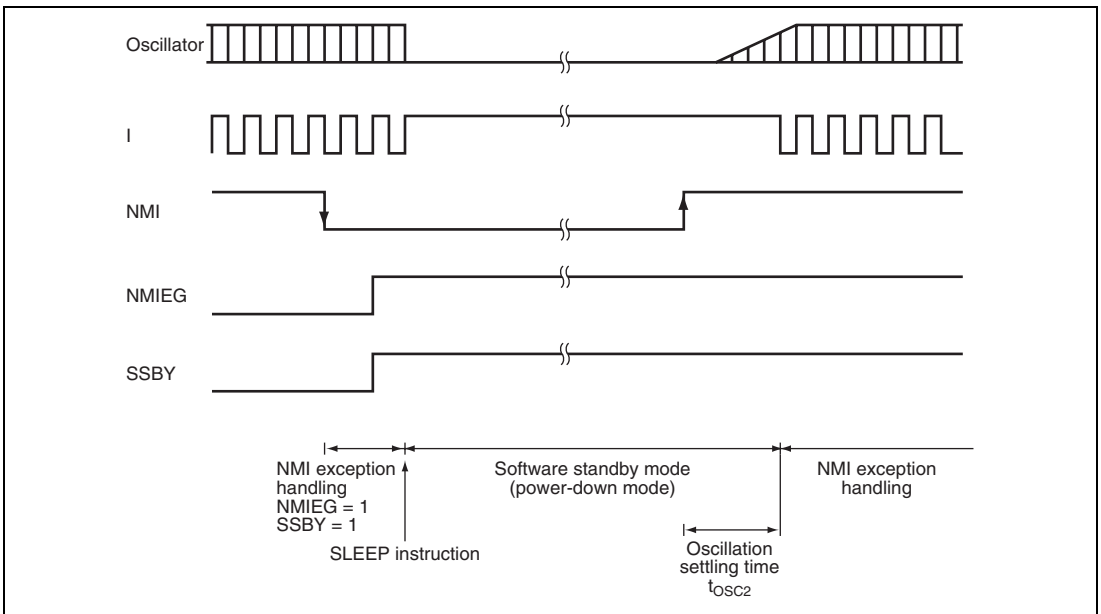

Figure 25.2 Software Standby Mode Application Example

25.8 Deep Software Standby Mode

25.8.1 Transition to Deep Software Standby Mode

If a SLEEP instruction is executed when the SSBY bit in SBYCR has been set to 1, a transition to software standby mode is made. In this state, if the DPSBY bit in DPSBYCR is set to 1, a transition to deep software standby mode is made.

If a software standby mode clearing source (an NMI, IRQ0 to IRQ15, or voltage-monitoring* interrupt requests) occurs when a transition to software standby mode is made, software standby mode will be cleared regardless of the DPSBY bit setting, and the interrupt exception handling starts after the oscillation settling time for software standby mode specified by the bits STS4 to STS0 in SBYCR has elapsed.

When both of the SSBY bit in SBYCR and the DPSBY bit in DPSBYCR are set to 1 and no software standby mode-clearing source occurs, a transition to deep software standby mode will be made immediately after software standby mode is entered.

In deep software standby mode, the CPU, on-chip peripheral functions, on-chip RAMs 6 to 4, and oscillator functionality are all halted. In addition, the internal power supply to these modules stops, resulting in a significant reduction in power consumption. At this time, the contents of all the registers of the CPU, on-chip peripheral functions, and on-chip RAMs 6 to 4 become undefined.

Contents of the on-chip RAMs 3 to 0 can be retained when all the bits RAMCUT2 to RAMCUT0 in DPSBYCR have been cleared to 0. If these bits are set to all 1, the internal power supply to the on-chip RAMs 3 to 0 stops and the power consumption is further reduced. At this time, the contents of the on-chip RAMs 3 to 0 become undefined.

The voltage detection circuit* and power-on reset circuit* can operate in deep software standby mode.

The I/O ports can be retained in the same state as in software standby mode.

Note: * Supported only by the H8SX/I638L Group.

25.8.2 Exit from Deep Software Standby Mode

Exit from deep software standby mode is initiated by signals on the external interrupt pins (NMI and $\overline{\text{IRQ0-A}}$ to $\overline{\text{IRQ3-A}}$), internal interrupt (voltage-monitoring interrupt*), voltage-monitoring reset*, power-on reset*, $\overline{\text{RES}}$ pin, or $\overline{\text{STBY}}$ pin.

1. Exit from deep software standby mode by external interrupt pins

Deep software standby mode is canceled when any of the DNMIF and DIRQnF ($n = 3$ to 0) bits, and DLVDIF bit* in DPSIFR is set to 1. The DNMIF or DIRQnF ($n = 3$ to 0) bit is set to 1 when a specified edge is generated in the NMI or $\overline{\text{IRQ0-A}}$ to $\overline{\text{IRQ3-A}}$ pins, that has been enabled by the DIRQnE ($n = 3$ to 0) bit in DPSIER . The rising or falling edge of the signals can be specified with DPSIEGR . The DLVDIF bit is set to 1 when a voltage-monitoring reset is generated. The DLVDIF bit is set to 1 when a voltage-monitoring interrupt is generated.

When deep software standby mode clearing source is generated, internal power supply starts simultaneously with the start of clock oscillation, and internal reset signal is generated for the entire LSI. Once the time specified by the WTSTS5 to WTSTS0 bits in DPSWCR has elapsed, a stable clock signal is being supplied throughout the LSI and the internal reset is cleared.

Deep software standby mode is canceled on clearing of the internal reset, and then the reset exception handling starts.

When deep software standby mode is canceled by an external interrupt pin, the DPSRSTF bit in RSTSR is set to 1.

2. Exit from deep software standby mode by a voltage-monitoring reset*

When a voltage monitoring reset is generated by the power-supply voltage falling, the LSI is released from deep software standby mode and clock oscillation starts. At the same time, a clock signal is supplied throughout the LSI. When the power-supply voltage has risen sufficiently, the LSI is released from the voltage-detection reset state. The CPU then starts reset-exception handling.

3. Exit from power-on reset*

When a power-on reset is generated by the power-supply voltage falling, the LSI is released from deep software standby mode. If the power-supply voltage then rises sufficiently, clock oscillation starts and the LSI is released from the power-on reset state after the clock oscillation stabilization time has been secured. As soon as the clock oscillation starts, the clock signal is provided to the LSI. After that, the CPU starts reset-exception handling.

4. Exit from deep software standby mode by the signal on the $\overline{\text{RES}}$ pin

Clock oscillation and internal power supply start as soon as the signal on the $\overline{\text{RES}}$ pin is driven low. At the same time, clock signals are supplied to the LSI. In this case, the $\overline{\text{RES}}$ pin has to be held low until the clock oscillation has become stable. Once the signal on the $\overline{\text{RES}}$ pin is driven high, the CPU starts reset exception handling.

5. Exit from deep software standby mode by the signal on the $\overline{\text{STBY}}$ pin

When the $\overline{\text{STBY}}$ pin is driven low, a transition is made to hardware standby mode.

Note: * Supported only by the H8SX/1638L Group.

25.8.3 Pin State on Exit from Deep Software Standby Mode

In deep software standby mode, the ports retain the states that were held during software standby mode. The internal of the LSI is initialized by an internal reset caused by deep software standby mode, and the reset exception handling starts as soon as deep software standby mode is canceled. The following shows the port states at this time.

(1) Pins for address bus, bus control and data bus

Pins for the address bus, bus control signals ($\overline{\text{CS0}}$, $\overline{\text{AS}}$, $\overline{\text{HWR}}$ and $\overline{\text{LWR}}$), and data bus operate depending on the CPU.

(2) Pins other than address bus, bus control and data bus pins

Whether the ports are initialized or retain the states that were held during software standby mode can be selected by the IOKEEP bit.

- When IOKEEP = 0

Ports are initialized by an internal reset caused by deep software standby mode.

- When IOKEEP = 1

The port states that were held in deep software standby mode are retained regardless of the LSI internal state though the internal of the LSI is initialized by an internal reset caused by deep software standby mode. At this time, the port states that were held in software standby mode are retained even if settings of I/O ports or peripheral modules are set. Subsequently, the retained port states are released when the IOKEEP bit is cleared to 0 and operation is performed according to the internal settings.

IOKEEP bit is not initialized by an internal reset caused by clearing deep software standby mode.

25.8.4 B ϕ Operation after Exit from Deep Software Standby Mode

When the IOKEEP bit is 0, B ϕ output is undefined for a maximum of one cycle immediately after exit from deep software standby mode. At this time, the output state cannot be guaranteed. Even when the IOKEEP bit is set to 1, B ϕ output is undefined for a maximum of one cycle immediately after the IOKEEP bit is cleared to 0 after deep software standby mode was canceled, and the output state cannot be guaranteed. (See figure 25.3)

However, clock can be normally output by canceling deep software standby mode with the IOKEEP bit set to 1 and then controlling the B ϕ output with the IOKEEP and PSTOP1 bits. Use the following procedure.

1. Change the value of the PSTOP1 bit from 0 to 1 to fix the B ϕ output at the high level (given that the B ϕ output was already fixed high).
2. Clear the IOKEEP bit to 0 to end retention of the B ϕ state.
3. Clear the PSTOP1 bit to 0 to enable B ϕ output.

For the port state when the IOKEEP bit is set to 1, see section 25.8.3, Pin State on Exit from Deep Software Standby Mode.

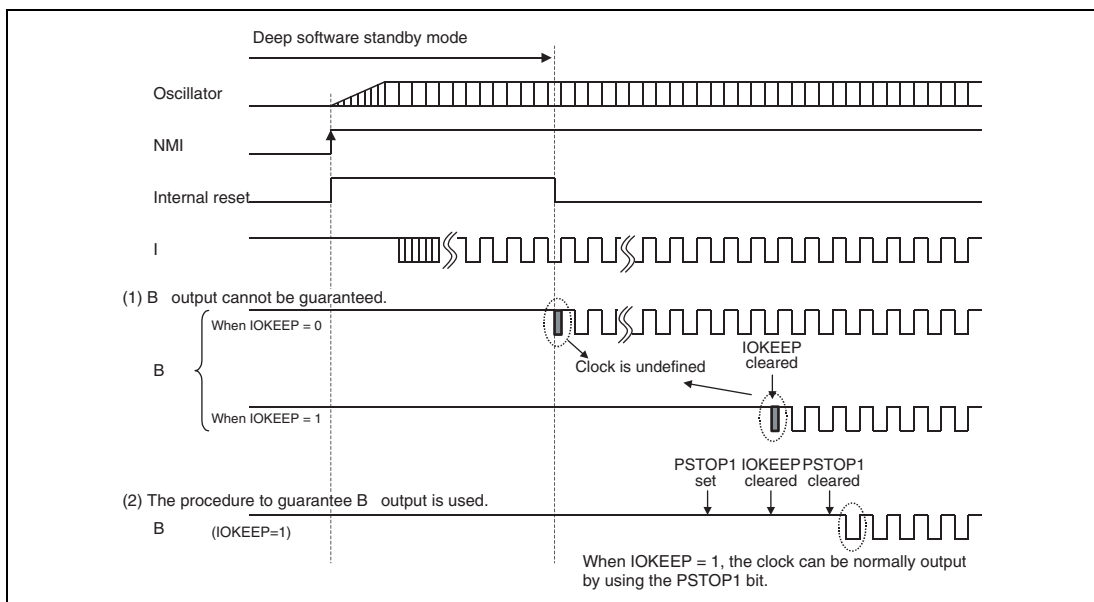

Figure 25.3 B ϕ Operation after Exit from Deep Software Standby Mode

25.8.5 Setting Oscillation Settling Time after Exit from Deep Software Standby Mode

The WTSTS5 to WTSTS0 bits in DPSWCR should be set as follows:

1. Using a crystal resonator

Specify the WTSTS5 to WTSTS0 bits so that the standby time is at least equal to the oscillation settling time. Table 25.3 shows EXTAL input clock frequencies and the standby time according to WTSTS5 to WTSTS0 settings.

2. Using an external clock

The PLL circuit settling time should be considered. See table 25.3 to set the standby time.

Table 25.3 Oscillation Settling Time Settings

WT STS5	WT STS4	WT STS3	WT STS2	WT STS1	WT STS0	Standby Time	EXTAL Input Clock Frequency* (MHz)						Unit												
							18	16	14	12	10	8													
0	0	0	0	0	0	Reserved	—	—	—	—	—	—	μs												
						1	Reserved	—	—	—	—	—		—											
						1	0	Reserved	—	—	—	—		—	—										
							1	Reserved	—	—	—	—		—	—										
						1	0	0	0	0	Reserved	—		—	—	—	—	—							
											1	64		3.6	4.0	4.6	5.3	6.4	8.0						
											1	0		512	0	512	28.4	32.0	36.6	42.7	51.2	64.0			
															1	1024	56.9	64.0	73.1	85.3	102.4	128.0			
															1	0	2048	0	2048	113.8	128.0	146.3	170.7	204.8	256.0
																		1	4096	0.23	0.26	0.29	0.34	0.41	0.51
						1	0	0	0	0	16384	0.91		1.02	1.17	1.37	1.64	2.05							
											1	32768		1.82	2.05	2.34	2.73	3.28	4.10						
1	0	0	0	0	0	65536	3.64	4.10	4.68	5.46	6.55	8.19													
						1	131072	7.28	8.19	9.36	10.92	13.11	16.38												
						1	0	262144	0	262144	14.56	16.38	18.72	21.85	26.21	32.77									
									1	524288	29.13	32.77	37.45	43.69	52.43	65.54									
1	0	0	0	0	0	Reserved	—	—	—	—	—														

[Legend]

 : Recommended setting when external clock is in use

 : Recommended setting when crystal oscillator is in use

Note: * The oscillation settling time, which includes a period where the oscillation by an oscillator is not stable, depends on the resonator characteristics.
The above figures are for reference.

25.8.6 Deep Software Standby Mode Application Example

(1) Transition to and Exit from Deep Software Standby Mode

Figure 25.4 shows an example where the transition to deep software standby mode is initiated by a falling edge on the NMI pin and exit from deep software standby mode is initiated by a rising edge on the NMI pin.

In this example, falling-edge sensing of NMI interrupts has been specified by clearing the NMIEG bit in INTCR to 0 (not shown). After an NMI interrupt has been sensed, rising-edge sensing is specified by setting the DNMIEG bit to 1, the SSBY and DPSBY bits are set to 1, and the transition to deep software standby mode is triggered by execution of a SLEEP instruction.

After that, deep software standby mode is canceled at the rising edge on the NMI pin.

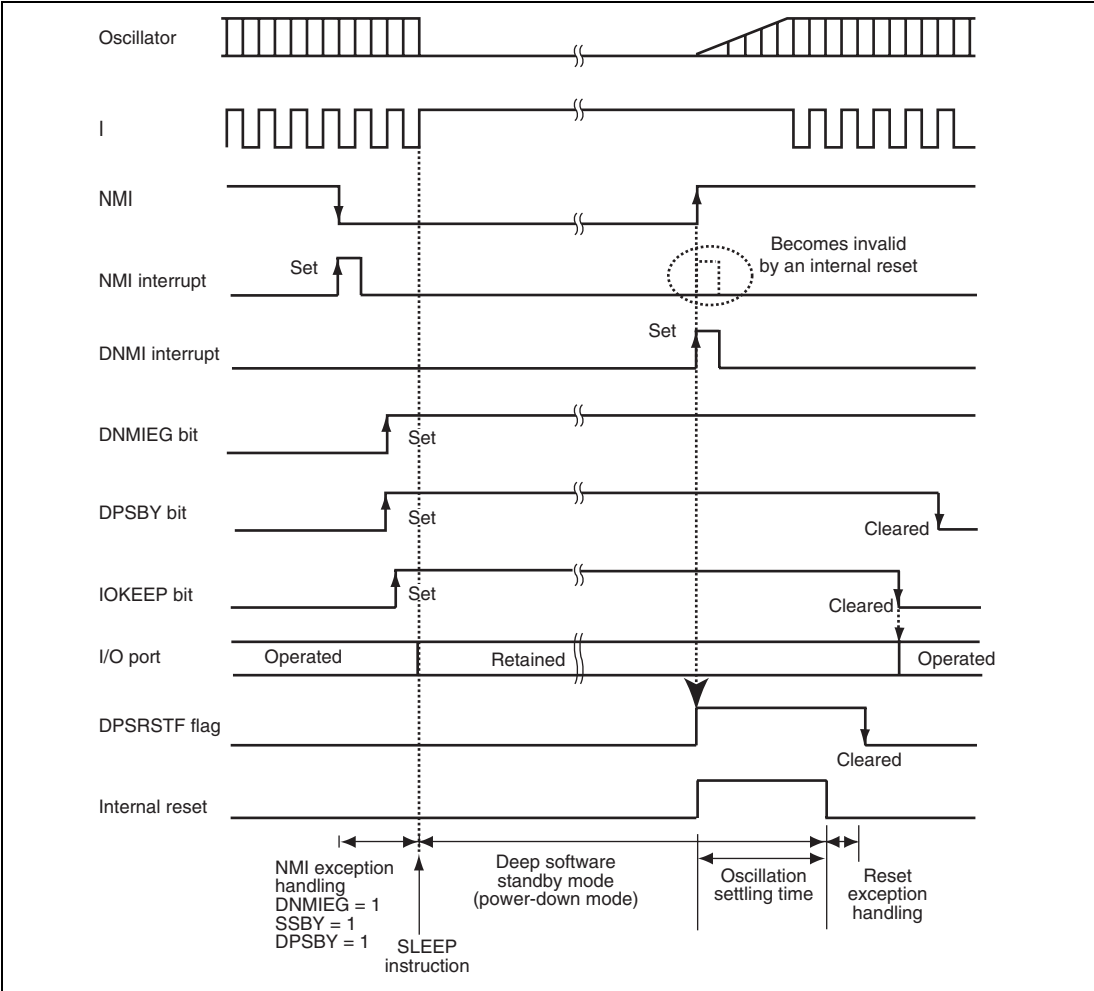

Figure 25.4 Deep Software Standby Mode Application Example (IOKEEP = 1)

(2) Deep Software Standby Mode in External Extended Mode (IOKEEP = 1)

Figure 25.5 shows an example of operations in deep standby mode when the IOKEEP and OPE bits are set to 1 in external extended mode.

In this example, deep software standby mode is entered with the IOKEEP and OPE bits set to 1, and then exited at the rising edge of the NMI pin. In external extended mode, while the IOKEEP bit is set to 1, retention of the states of pins for the address bus, bus-control signals ($\overline{CS0}$, \overline{AS} , \overline{RD} , \overline{HWR} , and \overline{LWR}), data bus is released after the oscillation settling time has elapsed. For other pins, including the B ϕ output pin, retention is released when the IOKEEP bit is cleared to 0, and then they are set according to the I/O port or peripheral module settings.

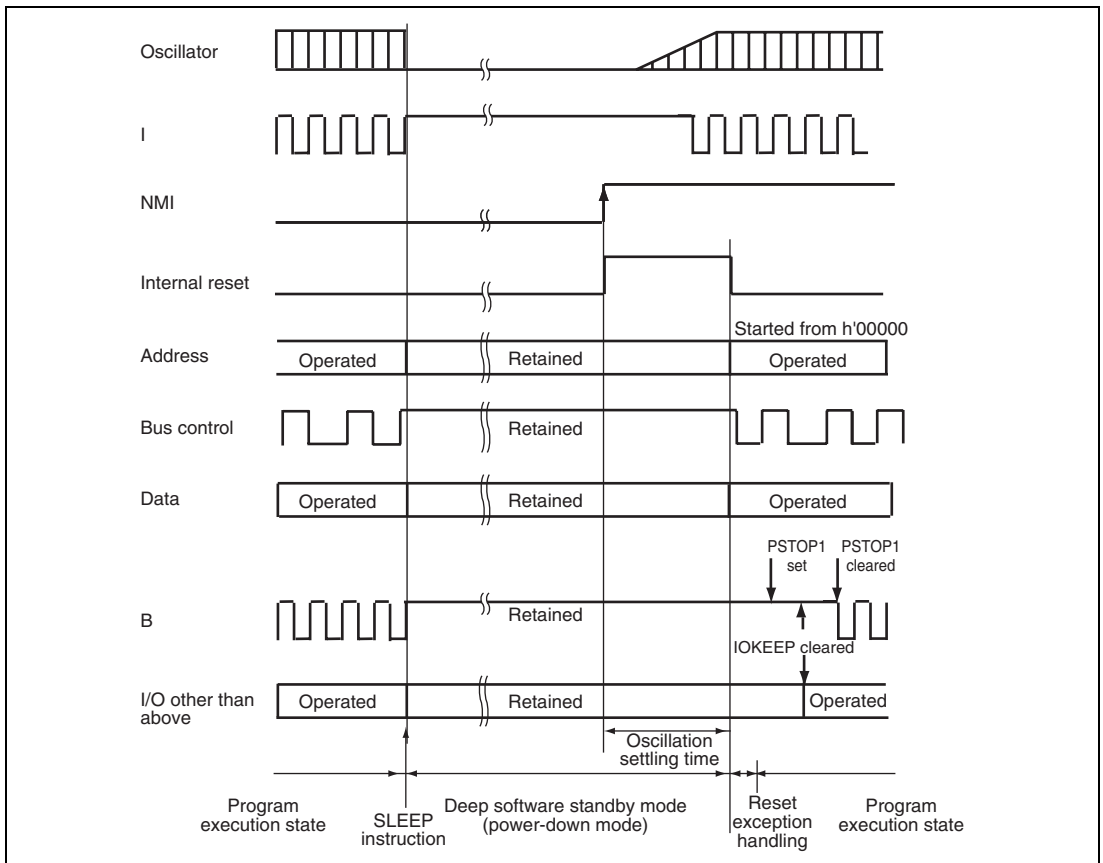

Figure 25.5 Example of Deep Software Standby Mode Operation in External Extended Mode (IOKEEP = OPE = 1)

(3) Deep Software Standby Mode in External Extended Mode (IOKEEP = 0)

Figure 25.6 shows an example of operations in deep software standby mode with the IOKEEP bit is cleared to 0 and the OPE bit is set to 1 in external extended mode. When the IOKEEP bit is cleared to 0, retention of the states of pins including the address bus, bus-control signals ($\overline{CS0}$, \overline{AS} , \overline{RD} , \overline{HWR} , and \overline{LWR}), data bus, and other pins including $B\phi$ output is released after the oscillation settling time has elapsed.

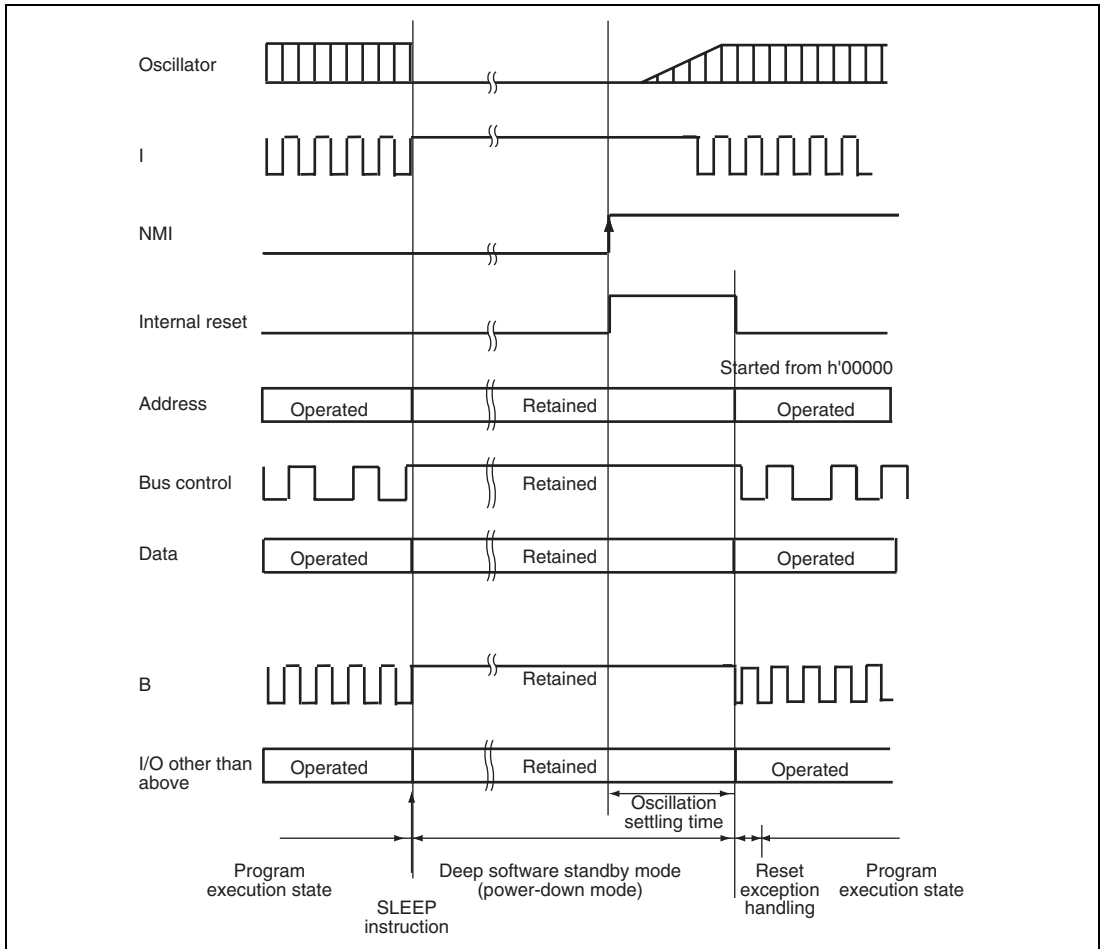

Figure 25.6 Example of Deep Software Standby Mode Operation in External Extended Mode (IOKEEP = 0, OPE = 1)

25.8.7 Flowchart of Deep Software Standby Mode Operation

Figure 25.7 shows an example of flowchart of deep software standby mode operation. In this example, reading the DPSRSTF bit determines whether a reset was generated by the $\overline{\text{RES}}$ pin or exit from deep software standby mode, after the reset exception handling was performed.

When a reset was caused by the $\overline{\text{RES}}$ pin, deep software standby mode is entered after required register settings.

When a reset was caused by exit from deep software standby mode, the IOKEEP bit is cleared after the I/O ports setting. When the IOKEEP bit is cleared, the setting to avoid an undefined state in $\text{B}\phi$ output is also set.

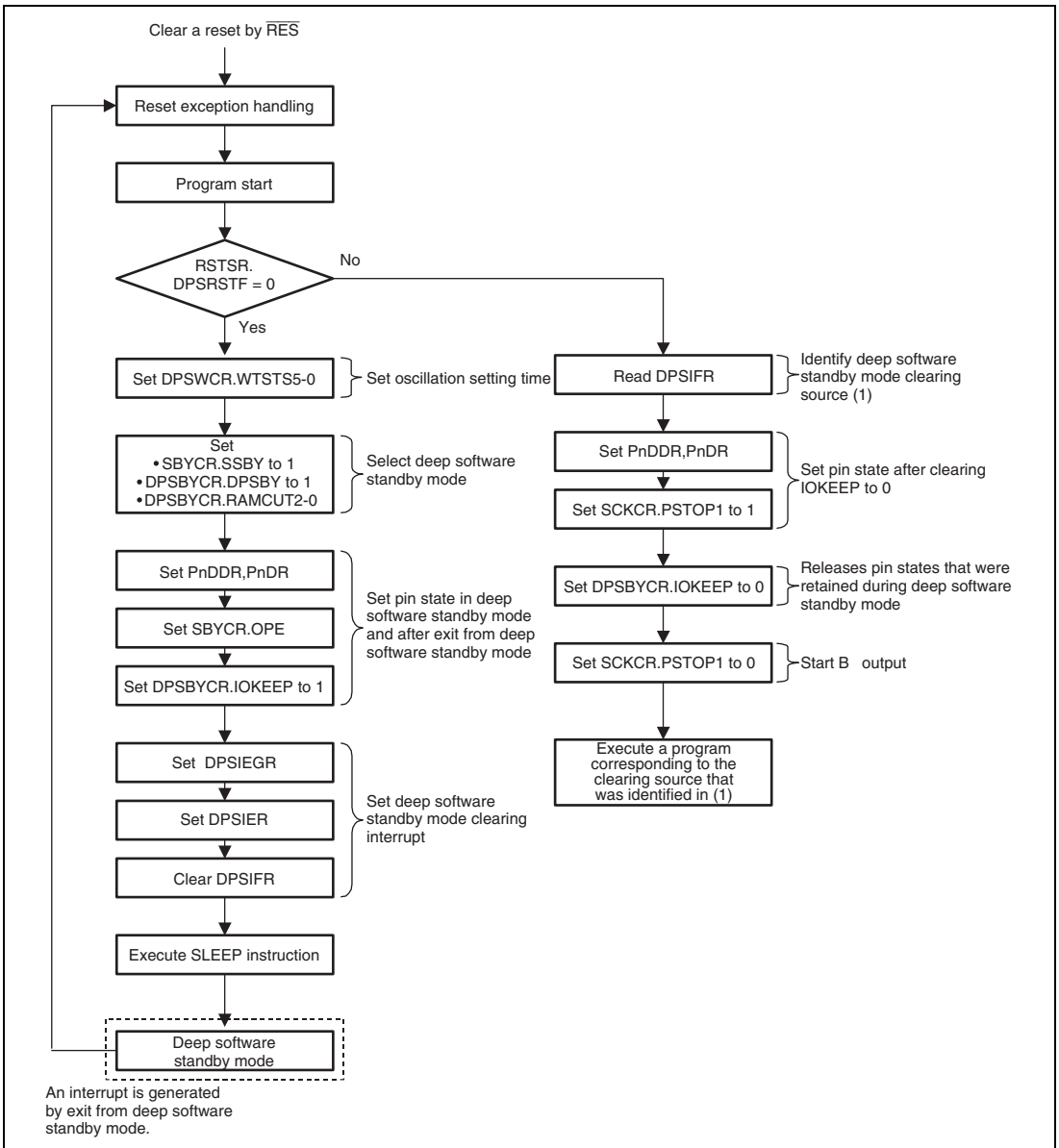

Figure 25.7 Flowchart of Deep Software Standby Mode Operation

25.9 Hardware Standby Mode

25.9.1 Transition to Hardware Standby Mode

When the $\overline{\text{STBY}}$ pin is driven low, a transition is made to hardware standby mode from any mode.

In hardware standby mode, all functions enter the reset state and stop operation, resulting in a significant reduction in power consumption. Data in the on-chip RAM is not retained because the internal power supply to the on-chip RAM stops. I/O ports are set to the high-impedance state.

Do not change the states of mode pins (MD2 to MD0) while this LSI is in hardware standby mode.

25.9.2 Clearing Hardware Standby Mode

Hardware standby mode is cleared by means of the $\overline{\text{STBY}}$ pin and the $\overline{\text{RES}}$ pin. When the $\overline{\text{STBY}}$ pin is driven high while the $\overline{\text{RES}}$ pin is low, the reset state is entered and clock oscillation is started. Ensure that the $\overline{\text{RES}}$ pin is held low until clock oscillation settles (for details on the oscillation settling time, refer to table 25.2). When the $\overline{\text{RES}}$ pin is subsequently driven high, a transition is made to the program execution state via the reset exception handling state.

25.9.3 Hardware Standby Mode Timing

Figure 25.8 shows an example of hardware standby mode timing.

When the $\overline{\text{STBY}}$ pin is driven low after the $\overline{\text{RES}}$ pin has been driven low, a transition is made to hardware standby mode. Hardware standby mode is cleared by driving the $\overline{\text{STBY}}$ pin high, waiting for the oscillation settling time, then changing the $\overline{\text{RES}}$ pin from low to high.

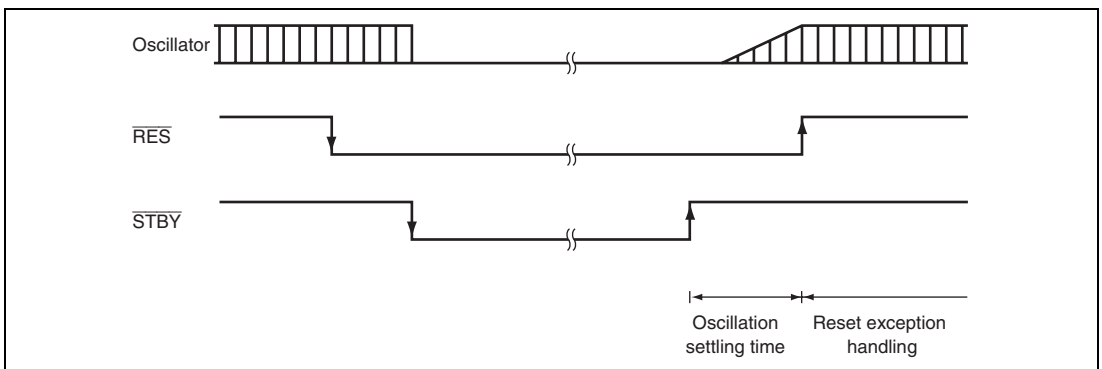

Figure 25.8 Hardware Standby Mode Timing

25.9.4 Timing Sequence at Power-On

Figure 25.9 shows the timing sequence at power-on.

At power-on, the $\overline{\text{RES}}$ pin must be driven low with the $\overline{\text{STBY}}$ pin driven high for a given time in order to clear the reset state.

To enter hardware standby mode immediately after power-on, drive the $\overline{\text{STBY}}$ pin low after exiting the reset state.

For details on clearing hardware standby mode, see section 25.9.3, Hardware Standby Mode Timing.

In a power-on reset*, power on while driving the $\overline{\text{STBY}}$ or $\overline{\text{RES}}$ pin to a high-level..

Note: * Supported only by the H8SX/1638L Group.

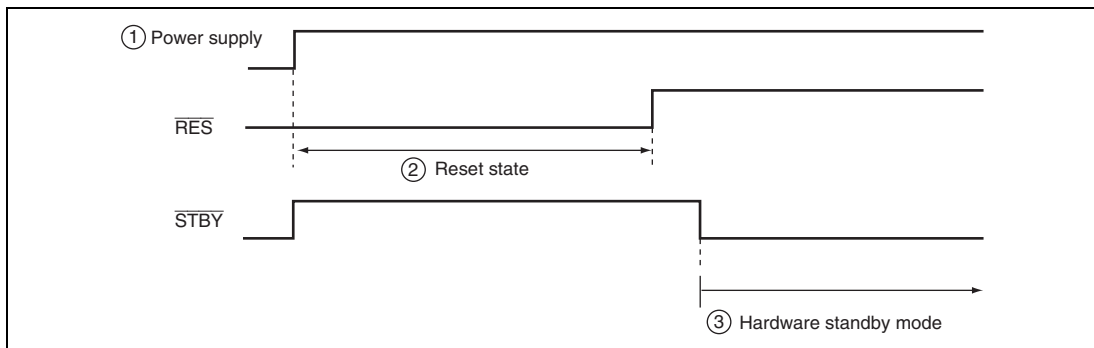

Figure 25.9 Timing Sequence at Power-On

25.10 Sleep Instruction Exception Handling

Sleep instruction exception handling is the exception handling initiated by the execution of a SLEEP instruction. Sleep instruction exception handling is always accepted while the program is in execution.

When the SLPIE bit is set to 0, the execution of a SLEEP instruction does not initiate sleep instruction exception handling. Instead, the CPU enters the power-down state. After this, generation of an exception handling request that cancels the power-down state causes the powerdown state to be canceled, after which the CPU starts to handle the exception. When the SLPIE bit is set to 1, sleep instruction exception handling starts after the execution of a SLEEP instruction. Transitions to the power-down state are inhibited when sleep instruction exception handling is initiated, and the CPU immediately starts sleep instruction exception handling.

When a SLEEP instruction is executed while the SLPIE bit is cleared to 0, a transition is made to the power-down state. The power-down state is canceled by a canceling factor interrupt (see figure 25.10).

When a canceling factor interrupt is generated immediately before the execution of a SLEEP instruction, exception handling for the interrupt starts. When execution returns from the exception service routine, the SLEEP instruction is executed to enter the power-down state. In this case, the power-down state is not canceled until the next canceling factor interrupt is generated (see figure 25.11).

When the SLPIE bit is set to 1 in the service routine for a canceling factor interrupt so that the execution of a SLEEP instruction will produce sleep instruction exception handling, the operation of the system is as shown in figure 25.12. Even if a canceling factor interrupt is generated immediately before the SLEEP instruction is executed, sleep instruction exception handling is initiated by execution of the SLEEP instruction. Therefore, the CPU executes the instruction that follows the SLEEP instruction after sleep instruction exception and exception service routine without shifting to the power-down state.

When the SLPIE bit is set to 1 to start sleep exception handling, clear the SSBY bit in SBYCR to 0.

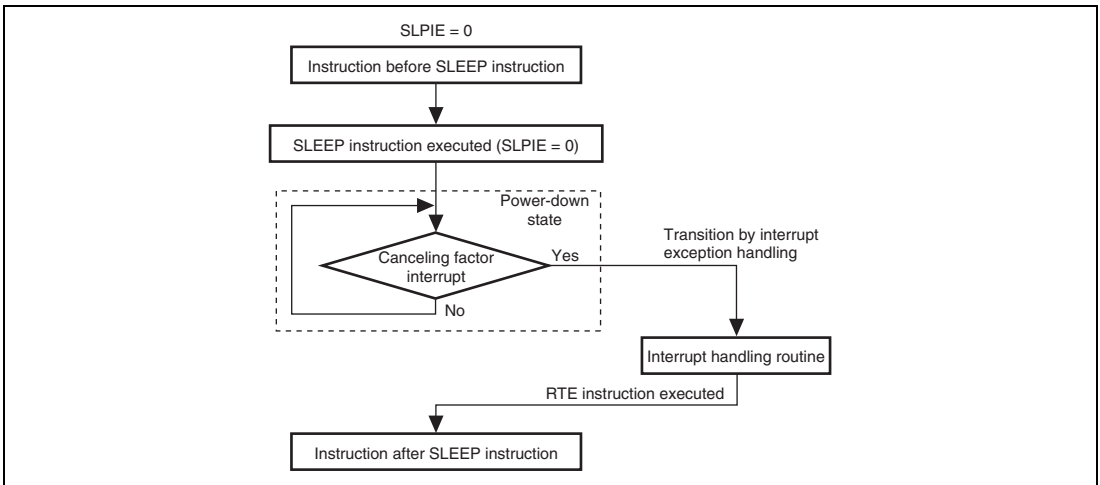

Figure 25.10 When Canceling Factor Interrupt is Generated after SLEEP Instruction Execution

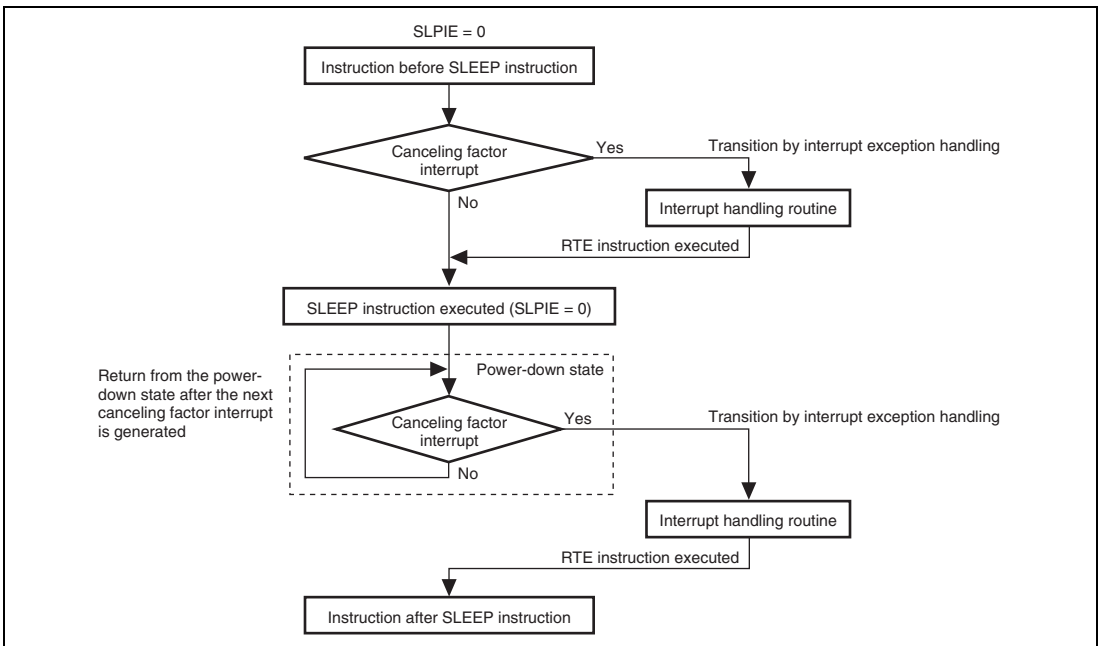

Figure 25.11 When Canceling Factor Interrupt is Generated before SLEEP Instruction Execution (Sleep Instruction Exception Handling Not Initiated)

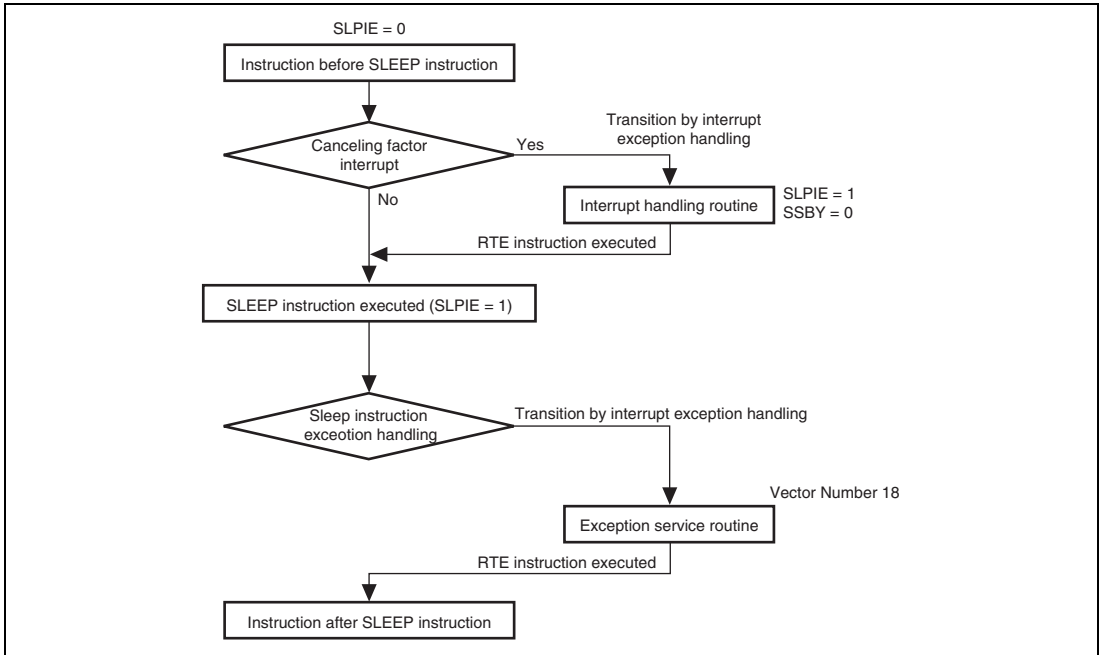

Figure 25.12 When Canceling Factor Interrupt is Generated before SLEEP Instruction Execution (Sleep Instruction Exception Handling Initiated)

25.11 B ϕ Clock Output Control

Output of the B ϕ clock can be controlled by the PSTOP1 bit in SCKCR, and DDR for the corresponding PA7 pin.

Clearing the PSTOP1 bit to 0 enables the B ϕ clock output on the PA7 pin. When bit PSTOP1 is set to 1, the B ϕ clock output stops at the end of the bus cycle, and the B ϕ clock output goes high. When DDR for the PA7 pin is cleared to 0, the B ϕ clock output is disabled and the pin becomes an input port. Tables 25.4 shows the states of the B ϕ pin in each processing state.

Table 25.4 ϕ Pin (PA7) State in Each Processing State

Register Setting Value		Normal Operating Mode	Sleep Mode	All-Module-Clock-Stop Mode	Software Standby Mode		Deep Software Standby Mode		Hardware Standby Mode
DDR	PSTOP1				OPE = 0	OPE = 1	IOKEEP = 0	IOKEEP = 1	
0	x	Hi-Z	Hi-Z	Hi-Z	Hi-Z	Hi-Z	Hi-Z	Hi-Z	Hi-Z
1	0	B ϕ output	B ϕ output	B ϕ output	High	High	High	High	Hi-Z
1	1	High	High	High	High	High	High	High	Hi-Z

[Legend]

x = Don't care

25.12 Usage Notes

25.12.1 I/O Port Status

In software standby mode or deep software standby mode, the I/O port states are retained. Therefore, there is no reduction in current drawn due to output currents when high-level signals are being output.

25.12.2 Current Consumption during Oscillation Settling Standby Period

Current consumption increases during the oscillation settling standby period.

25.12.3 Module Stop State of DMAC or DTC

Depending on the operating state of the DMAC and DTC, bits MSTPA13 and MSTPA12 may not be set to 1, respectively. The module stop state setting for the DMAC or DTC should be carried out only when the DMAC or DTC is not activated.

For details, refer to section 10, DMA Controller (DMAC), and section 11, Data Transfer Controller (DTC).

25.12.4 On-Chip Peripheral Module Interrupts

Relevant interrupt operations cannot be performed in a module stop state. Consequently, if module stop state is entered when an interrupt has been requested, it will not be possible to clear the CPU interrupt source or the DMAC or DTC activation source. Interrupts should therefore be disabled before entering a module stop state.

25.12.5 Writing to MSTPCRA, MSTPCRB, and MSTPCRC

MSTPCRA, MSTPCRB, and MSTPCRC should only be written to by the CPU.

25.12.6 Control of Input Buffers by DIRQnE (n = 3 to 0)

When the input buffers for the P10/ $\overline{\text{IRQ0}}$ -A to P13/ $\overline{\text{IRQ3}}$ -A pins are enabled by setting the DIRQnE bits (n = 3 to 0) in DSPIER to 1, the PnICR settings corresponding to these pins are invalid. Therefore, note that external inputs to these pins, of which states are reflected on the DIRQnF bits, are also input to the interrupt controller, peripheral modules and I/O ports, after the DIRQnE bits (n = 3 to 0) are set to 1.

25.12.7 Conflict between a transition to deep software standby mode and interrupts

If a conflict between a transition to deep software standby mode and generation of software standby mode clearing source occurs, a transition to deep software standby mode is not made but the software standby mode clearing sequence is executed. In this case, an interrupt exception handling for the input interrupt starts after the oscillation settling time for software standby mode (set by the STS4 to STS0 bits in SBYCR) has elapsed.

Note that if a conflict between a deep software standby mode transition and NMI interrupt occurs, the NMI interrupt exception handling routine is required.

If a conflict between a deep software standby mode transition, IRQ0 to IRQ15 interrupts, or voltage-monitoring interrupt* occurs, a transition to deep software standby mode can be made without executing the interrupt execution handling by clearing the SSIn bits in SSIER to 0 beforehand.

Note: * Supported only by the H8SX/1638L Group.

25.12.8 B ϕ Output State

B ϕ output is undefined for a maximum of one cycle immediately after deep software standby mode is canceled with the IOKEEP bit cleared to 0 or immediately after the IOKEEP bit is cleared after cancellation of deep software standby mode with the IOKEEP bit set to 1.

However, B ϕ can be normally output by setting the IOKEEP and PSTOP1 bits. For details, see section 25.8.4, B ϕ Operation after Exit from Deep Software Standby Mode.

Section 26 List of Registers

The register list gives information on the on-chip I/O register addresses, how the register bits are configured, and the register states in each operating mode. The information is given as shown below.

1. Register addresses (address order)
 - Registers are listed from the lower allocation addresses.
 - Registers are classified according to functional modules.
 - The number of Access Cycles indicates the number of states based on the specified reference clock. For details, refer to section 9.5.4, External Bus Interface.
 - Among the internal I/O register area, addresses not listed in the list of registers are undefined or reserved addresses. Undefined and reserved addresses cannot be accessed. Do not access these addresses; otherwise, the operation when accessing these bits and subsequent operations cannot be guaranteed.
2. Register bits
 - Bit configurations of the registers are listed in the same order as the register addresses.
 - Reserved bits are indicated by — in the bit name column.
 - Space in the bit name field indicates that the entire register is allocated to either the counter or data.
 - For the registers of 16 or 32 bits, the MSB is listed first.
 - Byte configuration description order is subject to big endian.
3. Register states in each operating mode
 - Register states are listed in the same order as the register addresses.
 - For the initialized state of each bit, refer to the register description in the corresponding section.
 - The register states shown here are for the basic operating modes. If there is a specific reset for an on-chip peripheral module, refer to the section on that on-chip peripheral module.

26.1 Register Addresses (Address Order)

Register Name	Abbreviation	Number of Bits	Address	Module	Data Width	Access Cycles (Read/Write)
Timer control register_4	TCR_4	8	H'FEA40	TMR_4	16	3Pφ/3Pφ
Timer control register_5	TCR_5	8	H'FEA41	TMR_5	16	3Pφ/3Pφ
Timer control/status register_4	TCSR_4	8	H'FEA42	TMR_4	16	3Pφ/3Pφ
Timer control/status register_5	TCSR_5	8	H'FEA43	TMR_5	16	3Pφ/3Pφ
Time constant register A_4	TCORA_4	8	H'FEA44	TMR_4	16	3Pφ/3Pφ
Time constant register A_5	TCORA_5	8	H'FEA45	TMR_5	16	3Pφ/3Pφ
Time constant register B_4	TCORB_4	8	H'FEA46	TMR_4	16	3Pφ/3Pφ
Time constant register B_5	TCORB_5	8	H'FEA47	TMR_5	16	3Pφ/3Pφ
Timer counter_4	TCNT_4	8	H'FEA48	TMR_4	16	3Pφ/3Pφ
Timer counter_5	TCNT_5	8	H'FEA49	TMR_5	16	3Pφ/3Pφ
Timer counter control register_4	TCCR_4	8	H'FEA4A	TMR_4	16	3Pφ/3Pφ
Timer counter control register_5	TCCR_5	8	H'FEA4B	TMR_5	16	3Pφ/3Pφ
CRC control register	CRCCR	8	H'FEA4C	CRC	16	3Pφ/3Pφ
CRC data input register	CRCDIR	8	H'FEA4D	CRC	16	3Pφ/3Pφ
CRC data output register	CRCDOR	16	H'FEA4E	CRC	16	3Pφ/3Pφ
Timer control register_6	TCR_6	8	H'FEA50	TMR_6	16	3Pφ/3Pφ
Timer control register_7	TCR_7	8	H'FEA51	TMR_7	16	3Pφ/3Pφ
Timer control/status register_6	TCSR_6	8	H'FEA52	TMR_6	16	3Pφ/3Pφ
Timer control/status register_7	TCSR_7	8	H'FEA53	TMR_7	16	3Pφ/3Pφ
Time constant register A_6	TCORA_6	8	H'FEA54	TMR_6	16	3Pφ/3Pφ
Time constant register A_7	TCORA_7	8	H'FEA55	TMR_7	16	3Pφ/3Pφ
Time constant register B_6	TCORB_6	8	H'FEA56	TMR_6	16	3Pφ/3Pφ
Time constant register B_7	TCORB_7	8	H'FEA57	TMR_7	16	3Pφ/3Pφ
Timer counter_6	TCNT_6	8	H'FEA58	TMR_6	16	3Pφ/3Pφ
Timer counter_7	TCNT_7	8	H'FEA59	TMR_7	16	3Pφ/3Pφ
Timer counter control register_6	TCCR_6	8	H'FEA5A	TMR_6	16	3Pφ/3Pφ
Timer counter control register_7	TCCR_7	8	H'FEA5B	TMR_7	16	3Pφ/3Pφ
A/D data register A_1	ADDRA_1	16	H'FEA80	A/D_1	16	3Pφ/3Pφ
A/D data register B_1	ADDRB_1	16	H'FEA82	A/D_1	16	3Pφ/3Pφ

Register Name	Abbreviation	Number of Bits	Address	Module	Data Width	Access Cycles (Read/Write)
A/D data register C_1	ADDRC_1	16	H'FEA84	A/D_1	16	3Pφ/3Pφ
A/D data register D_1	ADDRD_1	16	H'FEA86	A/D_1	16	3Pφ/3Pφ
A/D data register E_1	ADDRE_1	16	H'FEA90	A/D_1	16	3Pφ/3Pφ
A/D data register F_1	ADDRF_1	16	H'FEA92	A/D_1	16	3Pφ/3Pφ
A/D data register G_1	ADDRG_1	16	H'FEA94	A/D_1	16	3Pφ/3Pφ
A/D data register H_1	ADDRH_1	16	H'FEA96	A/D_1	16	3Pφ/3Pφ
A/D control/status register_1	ADCSR_1	8	H'FEAA0	A/D_1	16	3Pφ/3Pφ
A/D control register_1	ADCR_1	8	H'FEAA1	A/D_1	16	3Pφ/3Pφ
Serial mode register_5	SMR_5	8	H'FF600	SCI_5	8	3Pφ/3Pφ
Bit rate register_5	BRR_5	8	H'FF601	SCI_5	8	3Pφ/3Pφ
Serial control register_5	SCR_5	8	H'FF602	SCI_5	8	3Pφ/3Pφ
Transmit data register_5	TDR_5	8	H'FF603	SCI_5	8	3Pφ/3Pφ
Serial status register_5	SSR_5	8	H'FF604	SCI_5	8	3Pφ/3Pφ
Receive data register_5	RDR_5	8	H'FF605	SCI_5	8	3Pφ/3Pφ
Smart card mode register_5	SCMR_5	8	H'FF606	SCI_5	8	3Pφ/3Pφ
Serial extended mode register_5	SEMR_5	8	H'FF608	SCI_5	8	3Pφ/3Pφ
IrDA control register	IrCR	8	H'FF60C	SCI_5	8	3Pφ/3Pφ
Serial mode register_6	SMR_6	8	H'FF610	SCI_6	8	3Pφ/3Pφ
Bit rate register_6	BRR_6	8	H'FF611	SCI_6	8	3Pφ/3Pφ
Serial control register_6	SCR_6	8	H'FF612	SCI_6	8	3Pφ/3Pφ
Transmit data register_6	TDR_6	8	H'FF613	SCI_6	8	3Pφ/3Pφ
Serial status register_6	SSR_6	8	H'FF614	SCI_6	8	3Pφ/3Pφ
Receive data register_6	RDR_6	8	H'FF615	SCI_6	8	3Pφ/3Pφ
Smart card mode register_6	SCMR_6	8	H'FF616	SCI_6	8	3Pφ/3Pφ
Serial extended mode register_6	SEMR_6	8	H'FF618	SCI_6	8	3Pφ/3Pφ
PPG output control register_1	PCR_1	8	H'FF636	PPG_1	8	3Pφ/3Pφ
PPG output mode register_1	PMR_1	8	H'FF637	PPG_1	8	3Pφ/3Pφ
Next data enable register H_1	NDERH_1	8	H'FF638	PPG_1	8	3Pφ/3Pφ
Next data enable register L_1	NDERL_1	8	H'FF639	PPG_1	8	3Pφ/3Pφ
Output data register H_1	PODRH_1	8	H'FF63A	PPG_1	8	3Pφ/3Pφ
Output data register L_1	PODRL_1	8	H'FF63B	PPG_1	8	3Pφ/3Pφ

Register Name	Abbreviation	Number of Bits	Address	Module	Data Width	Access Cycles (Read/Write)
Next data register H_1* ¹	NDRH_1	8	H'FF63C	PPG_1	8	3P ϕ /3P ϕ
Next data register L_1* ¹	NDRL_1	8	H'FF63D	PPG_1	8	3P ϕ /3P ϕ
Next data register H_1* ¹	NDRH_1	8	H'FF63E	PPG_1	8	3P ϕ /3P ϕ
Next data register L_1* ¹	NDRL_1	8	H'FF63F	PPG_1	8	3P ϕ /3P ϕ
Break address register AH	BARAH	16	H'FFA02	UBC	16	2I ϕ /2I ϕ
Break address register AL	BARAL	16	H'FFA02	UBC	16	2I ϕ /2I ϕ
Break address mask register AH	BAMRAH	16	H'FFA04	UBC	16	2I ϕ /2I ϕ
Break address mask register AL	BAMRAL	16	H'FFA06	UBC	16	2I ϕ /2I ϕ
Break address register BH	BARBH	16	H'FFA08	UBC	16	2I ϕ /2I ϕ
Break address register BL	BARBL	16	H'FFA0A	UBC	16	2I ϕ /2I ϕ
Break address mask register BH	BAMRBH	16	H'FFA0C	UBC	16	2I ϕ /2I ϕ
Break address mask register BL	BAMRBL	16	H'FFA0E	UBC	16	2I ϕ /2I ϕ
Break address register CH	BARCH	16	H'FFA10	UBC	16	2I ϕ /2I ϕ
Break address register CL	BARCL	16	H'FFA12	UBC	16	2I ϕ /2I ϕ
Break address mask register CH	BAMRCH	16	H'FFA14	UBC	16	2I ϕ /2I ϕ
Break address mask register CL	BAMRCL	16	H'FFA16	UBC	16	2I ϕ /2I ϕ
Break address register DH	BARDH	16	H'FFA18	UBC	16	2I ϕ /2I ϕ
Break address register DL	BARDL	16	H'FFA1A	UBC	16	2I ϕ /2I ϕ
Break address mask register DH	BAMRDH	16	H'FFA1C	UBC	16	2I ϕ /2I ϕ
Break address mask register DL	BAMRDL	16	H'FFA1E	UBC	16	2I ϕ /2I ϕ
Break control register A	BRCRA	16	H'FFA28	UBC	16	2I ϕ /2I ϕ
Break control register B	BRCRB	16	H'FFA2C	UBC	16	2I ϕ /2I ϕ
Break control register C	BRCRC	16	H'FFA30	UBC	16	2I ϕ /2I ϕ
Break control register D	BRCRD	16	H'FFA34	UBC	16	2I ϕ /2I ϕ
Timer start register	TSTRB	8	H'FFB00	TPU (unit 1)	16	2P ϕ /2P ϕ
Timer synchronous register	TSYRB	8	H'FFB01	TPU (unit 1)	16	2P ϕ /2P ϕ
Timer control register_6	TCR_6	8	H'FFB10	TPU_6	16	2P ϕ /2P ϕ
Timer mode register_6	TMDR_6	8	H'FFB11	TPU_6	16	2P ϕ /2P ϕ
Timer I/O control register H_6	TIORH_6	8	H'FFB12	TPU_6	16	2P ϕ /2P ϕ
Timer I/O control register L_6	TIORL_6	8	H'FFB13	TPU_6	16	2P ϕ /2P ϕ

Register Name	Abbreviation	Number of Bits	Address	Module	Data Width	Access Cycles (Read/Write)
Timer interrupt enable register_6	TIER_6	8	H'FFB14	TPU_6	16	2P ϕ /2P ϕ
Timer status register_6	TSR_6	8	H'FFB15	TPU_6	16	2P ϕ /2P ϕ
Timer counter_6	TCNT_6	16	H'FFB16	TPU_6	16	2P ϕ /2P ϕ
Timer general register A_6	TGRA_6	16	H'FFB18	TPU_6	16	2P ϕ /2P ϕ
Timer general register B_6	TGRB_6	16	H'FFB1A	TPU_6	16	2P ϕ /2P ϕ
Timer general register C_6	TGRC_6	16	H'FFB1C	TPU_6	16	2P ϕ /2P ϕ
Timer general register D_6	TGRD_6	16	H'FFB1E	TPU_6	16	2P ϕ /2P ϕ
Timer control register_7	TCR_7	8	H'FFB20	TPU_7	16	2P ϕ /2P ϕ
Timer mode register_7	TMDR_7	8	H'FFB21	TPU_7	16	2P ϕ /2P ϕ
Timer I/O control register_7	TIOR_7	8	H'FFB22	TPU_7	16	2P ϕ /2P ϕ
Timer interrupt enable register_7	TIER_7	8	H'FFB24	TPU_7	16	2P ϕ /2P ϕ
Timer status register_7	TSR_7	8	H'FFB25	TPU_7	16	2P ϕ /2P ϕ
Timer counter_7	TCNT_7	16	H'FFB26	TPU_7	16	2P ϕ /2P ϕ
Timer general register A_7	TGRA_7	16	H'FFB28	TPU_7	16	2P ϕ /2P ϕ
Timer general register B_7	TGRB_7	16	H'FFB2A	TPU_7	16	2P ϕ /2P ϕ
Timer control register_8	TCR_8	8	H'FFB30	TPU_8	16	2P ϕ /2P ϕ
Timer mode register_8	TMDR_8	8	H'FFB31	TPU_8	16	2P ϕ /2P ϕ
Timer I/O control register_8	TIOR_8	8	H'FFB32	TPU_8	16	2P ϕ /2P ϕ
Timer interrupt enable register_8	TIER_8	8	H'FFB34	TPU_8	16	2P ϕ /2P ϕ
Timer status register_8	TSR_8	8	H'FFB35	TPU_8	16	2P ϕ /2P ϕ
Timer counter_8	TCNT_8	16	H'FFB36	TPU_8	16	2P ϕ /2P ϕ
Timer general register A_8	TGRA_8	16	H'FFB38	TPU_8	16	2P ϕ /2P ϕ
Timer general register B_8	TGRB_8	16	H'FFB3A	TPU_8	16	2P ϕ /2P ϕ
Timer control register_9	TCR_9	8	H'FFB40	TPU_9	16	2P ϕ /2P ϕ
Timer mode register_9	TMDR_9	8	H'FFB41	TPU_9	16	2P ϕ /2P ϕ
Timer I/O control register H_9	TIORH_9	8	H'FFB42	TPU_9	16	2P ϕ /2P ϕ
Timer I/O control register L_9	TIORL_9	8	H'FFB43	TPU_9	16	2P ϕ /2P ϕ
Timer interrupt enable register_9	TIER_9	8	H'FFB44	TPU_9	16	2P ϕ /2P ϕ
Timer status register_9	TSR_9	8	H'FFB45	TPU_9	16	2P ϕ /2P ϕ
Timer counter_9	TCNT_9	16	H'FFB46	TPU_9	16	2P ϕ /2P ϕ
Timer general register A_9	TGRA_9	16	H'FFB48	TPU_9	16	2P ϕ /2P ϕ

Register Name	Abbreviation	Number of Bits	Address	Module	Data Width	Access Cycles (Read/Write)
Timer general register B_9	TGRB_9	16	H'FFB4A	TPU_9	16	2P ϕ /2P ϕ
Timer general register C_9	TGRC_9	16	H'FFB4C	TPU_9	16	2P ϕ /2P ϕ
Timer general register D_9	TGRD_9	16	H'FFB4E	TPU_9	16	2P ϕ /2P ϕ
Timer control register_10	TCR_10	8	H'FFB50	TPU_10	16	2P ϕ /2P ϕ
Timer mode register_10	TMDR_10	8	H'FFB51	TPU_10	16	2P ϕ /2P ϕ
Timer I/O control register_10	TIOR_10	8	H'FFB52	TPU_10	16	2P ϕ /2P ϕ
Timer interrupt enable register_10	TIER_10	8	H'FFB54	TPU_10	16	2P ϕ /2P ϕ
Timer status register_10	TSR_10	8	H'FFB55	TPU_10	16	2P ϕ /2P ϕ
Timer counter_10	TCNT_10	16	H'FFB56	TPU_10	16	2P ϕ /2P ϕ
Timer general register A_10	TGRA_10	16	H'FFB58	TPU_10	16	2P ϕ /2P ϕ
Timer general register B_10	TGRB_10	16	H'FFB5A	TPU_10	16	2P ϕ /2P ϕ
Timer control register_11	TCR_11	8	H'FFB60	TPU_11	16	2P ϕ /2P ϕ
Timer mode register_11	TMDR_11	8	H'FFB61	TPU_11	16	2P ϕ /2P ϕ
Timer I/O control register_11	TIOR_11	8	H'FFB62	TPU_11	16	2P ϕ /2P ϕ
Timer interrupt enable register_11	TIER_11	8	H'FFB64	TPU_11	16	2P ϕ /2P ϕ
Timer status register_11	TSR_11	8	H'FFB65	TPU_11	16	2P ϕ /2P ϕ
Timer counter_11	TCNT_11	16	H'FFB66	TPU_11	16	2P ϕ /2P ϕ
Timer general register A_11	TGRA_11	16	H'FFB68	TPU_11	16	2P ϕ /2P ϕ
Timer general register B_11	TGRB_11	16	H'FFB6A	TPU_11	16	2P ϕ /2P ϕ
Port 1 data direction register	P1DDR	8	H'FFB80	I/O port	8	2P ϕ /2P ϕ
Port 2 data direction register	P2DDR	8	H'FFB81	I/O port	8	2P ϕ /2P ϕ
Port 3 data direction register	P3DDR	8	H'FFB82	I/O port	8	2P ϕ /2P ϕ
Port 6 data direction register	P6DDR	8	H'FFB85	I/O port	8	2P ϕ /2P ϕ
Port A data direction register	PADDR	8	H'FFB89	I/O port	8	2P ϕ /2P ϕ
Port B data direction register	PBDDR	8	H'FFB8A	I/O port	8	2P ϕ /2P ϕ
Port D data direction register	PDDDR	8	H'FFB8C	I/O port	8	2P ϕ /2P ϕ
Port E data direction register	PEDDR	8	H'FFB8D	I/O port	8	2P ϕ /2P ϕ
Port F data direction register	PFDDR	8	H'FFB8E	I/O port	8	2P ϕ /2P ϕ
Port 1 input buffer control register	P1ICR	8	H'FFB90	I/O port	8	2P ϕ /2P ϕ
Port 2 input buffer control register	P2ICR	8	H'FFB91	I/O port	8	2P ϕ /2P ϕ
Port 3 input buffer control register	P3ICR	8	H'FFB92	I/O port	8	2P ϕ /2P ϕ

Register Name	Abbreviation	Number of Bits	Address	Module	Data Width	Access Cycles (Read/Write)
Port 5 input buffer control register	P5ICR	8	H'FFB94	I/O port	8	2P ϕ /2P ϕ
Port 6 input buffer control register	P6ICR	8	H'FFB95	I/O port	8	2P ϕ /2P ϕ
Port A input buffer control register	PAICR	8	H'FFB99	I/O port	8	2P ϕ /2P ϕ
Port B input buffer control register	PBICR	8	H'FFB9A	I/O port	8	2P ϕ /2P ϕ
Port D input buffer control register	PDICR	8	H'FFB9C	I/O port	8	2P ϕ /2P ϕ
Port E input buffer control register	PEICR	8	H'FFB9D	I/O port	8	2P ϕ /2P ϕ
Port F input buffer control register	PFICR	8	H'FFB9E	I/O port	8	2P ϕ /2P ϕ
Port H register	PORTH	8	H'FFBA0	I/O port	8	2P ϕ /2P ϕ
Port I register	PORTI	8	H'FFBA1	I/O port	8	2P ϕ /2P ϕ
Port J register	PORTJ	8	H'FFBA2	I/O port	8	2P ϕ /2P ϕ
Port K register	PORTK	8	H'FFBA3	I/O port	8	2P ϕ /2P ϕ
Port H data register	PHDR	8	H'FFBA4	I/O port	8	2P ϕ /2P ϕ
Port I data register	PIDR	8	H'FFBA5	I/O port	8	2P ϕ /2P ϕ
Port J data register	PJDR	8	H'FFBA6	I/O port	8	2P ϕ /2P ϕ
Port K data register	PKDR	8	H'FFBA7	I/O port	8	2P ϕ /2P ϕ
Port H data direction register	PHDDR	8	H'FFBA8	I/O port	8	2P ϕ /2P ϕ
Port I data direction register	PIDDR	8	H'FFBA9	I/O port	8	2P ϕ /2P ϕ
Port J data direction register	PJDDR	8	H'FFBAA	I/O port	8	2P ϕ /2P ϕ
Port K data direction register	PKDDR	8	H'FFBAB	I/O port	8	2P ϕ /2P ϕ
Port H input buffer control register	PHICR	8	H'FFBAC	I/O port	8	2P ϕ /2P ϕ
Port I input buffer control register	PIICR	8	H'FFBAD	I/O port	8	2P ϕ /2P ϕ
Port J input buffer control register	PJICR	8	H'FFBAE	I/O port	8	2P ϕ /2P ϕ
Port K input buffer control register	PKICR	8	H'FFBAF	I/O port	8	2P ϕ /2P ϕ
Port D pull-up MOS control register	PDPCR	8	H'FFBB4	I/O port	8	2P ϕ /2P ϕ
Port E pull-up MOS control register	PEPCR	8	H'FFBB5	I/O port	8	2P ϕ /2P ϕ
Port F pull-up MOS control register	PFPCR	8	H'FFBB6	I/O port	8	2P ϕ /2P ϕ
Port H pull-up MOS control register	PHPCR	8	H'FFBB8	I/O port	8	2P ϕ /2P ϕ
Port I pull-up MOS control register	PIPCR	8	H'FFBB9	I/O port	8	2P ϕ /2P ϕ
Port J pull-up MOS control register	PJPCR	8	H'FFBBA	I/O port	8	2P ϕ /2P ϕ
Port K pull-up MOS control register	PKPCR	8	H'FFBBB	I/O port	8	2P ϕ /2P ϕ
Port 2 open-drain control register	P2ODR	8	H'FFBBC	I/O port	8	2P ϕ /2P ϕ

Register Name	Abbreviation	Number of Bits	Address	Module	Data Width	Access Cycles (Read/Write)
Port F open-drain control register	PFODR	8	H'FFBBD	I/O port	8	2P ϕ /2P ϕ
Port function control register 0	PFCR0	8	H'FFBC0	I/O port	8	2P ϕ /3P ϕ
Port function control register 1	PFCR1	8	H'FFBC1	I/O port	8	2P ϕ /3P ϕ
Port function control register 2	PFCR2	8	H'FFBC2	I/O port	8	2P ϕ /3P ϕ
Port function control register 4	PFCR4	8	H'FFBC4	I/O port	8	2P ϕ /3P ϕ
Port function control register 6	PFCR6	8	H'FFBC6	I/O port	8	2P ϕ /3P ϕ
Port function control register 7	PFCR7	8	H'FFBC7	I/O port	8	2P ϕ /3P ϕ
Port function control register 9	PFCR9	8	H'FFBC9	I/O port	8	2P ϕ /3P ϕ
Port function control register A	PFCRA	8	H'FFBCA	I/O port	8	2P ϕ /3P ϕ
Port function control register B	PFCRB	8	H'FFBCB	I/O port	8	2P ϕ /3P ϕ
Port function control register C	PFCRC	8	H'FFBCC	I/O port	8	2P ϕ /3P ϕ
Port function control register D	PFCRD	8	H'FFBCD	I/O port	8	2P ϕ /3P ϕ
Software standby release IRQ enable register	SSIER	16	H'FFBCE	INTC	8	2P ϕ /3P ϕ
Deep standby backup register 0	DPSBKR0	8	H'FFBF0	SYSTEM	8	2I ϕ /3I ϕ
Deep standby backup register 1	DPSBKR1	8	H'FFBF1	SYSTEM	8	2I ϕ /3I ϕ
Deep standby backup register 2	DPSBKR2	8	H'FFBF2	SYSTEM	8	2I ϕ /3I ϕ
Deep standby backup register 3	DPSBKR3	8	H'FFBF3	SYSTEM	8	2I ϕ /3I ϕ
Deep standby backup register 4	DPSBKR4	8	H'FFBF4	SYSTEM	8	2I ϕ /3I ϕ
Deep standby backup register 5	DPSBKR5	8	H'FFBF5	SYSTEM	8	2I ϕ /3I ϕ
Deep standby backup register 6	DPSBKR6	8	H'FFBF6	SYSTEM	8	2I ϕ /3I ϕ
Deep standby backup register 7	DPSBKR7	8	H'FFBF7	SYSTEM	8	2I ϕ /3I ϕ
Deep standby backup register 8	DPSBKR8	8	H'FFBF8	SYSTEM	8	2I ϕ /3I ϕ
Deep standby backup register 9	DPSBKR9	8	H'FFBF9	SYSTEM	8	2I ϕ /3I ϕ
Deep standby backup register 10	DPSBKR10	8	H'FFBFA	SYSTEM	8	2I ϕ /3I ϕ
Deep standby backup register 11	DPSBKR11	8	H'FFBFB	SYSTEM	8	2I ϕ /3I ϕ
Deep standby backup register 12	DPSBKR12	8	H'FFBFC	SYSTEM	8	2I ϕ /3I ϕ
Deep standby backup register 13	DPSBKR13	8	H'FFBFD	SYSTEM	8	2I ϕ /3I ϕ
Deep standby backup register 14	DPSBKR14	8	H'FFBFE	SYSTEM	8	2I ϕ /3I ϕ
Deep standby backup register 15	DPSBKR15	8	H'FFBFF	SYSTEM	8	2I ϕ /3I ϕ
DMA source address register_0	DSAR_0	32	H'FFC00	DMAC_0	16	2I ϕ /2I ϕ

Register Name	Abbreviation	Number of Bits	Address	Module	Data Width	Access Cycles (Read/Write)
DMA destination address register_0	DDAR_0	32	H'FFC04	DMAC_0	16	21 ϕ /21 ϕ
DMA offset register_0	DOFR_0	32	H'FFC08	DMAC_0	16	21 ϕ /21 ϕ
DMA transfer count register_0	DTCR_0	32	H'FFC0C	DMAC_0	16	21 ϕ /21 ϕ
DMA block size register_0	DBSR_0	32	H'FFC10	DMAC_0	16	21 ϕ /21 ϕ
DMA mode control register_0	DMDR_0	32	H'FFC14	DMAC_0	16	21 ϕ /21 ϕ
DMA address control register_0	DACR_0	32	H'FFC18	DMAC_0	16	21 ϕ /21 ϕ
DMA source address register_1	DSAR_1	32	H'FFC20	DMAC_1	16	21 ϕ /21 ϕ
DMA destination address register_1	DDAR_1	32	H'FFC24	DMAC_1	16	21 ϕ /21 ϕ
DMA offset register_1	DOFR_1	32	H'FFC28	DMAC_1	16	21 ϕ /21 ϕ
DMA transfer count register_1	DTCR_1	32	H'FFC2C	DMAC_1	16	21 ϕ /21 ϕ
DMA block size register_1	DBSR_1	32	H'FFC30	DMAC_1	16	21 ϕ /21 ϕ
DMA mode control register_1	DMDR_1	32	H'FFC34	DMAC_1	16	21 ϕ /21 ϕ
DMA address control register_1	DACR_1	32	H'FFC38	DMAC_1	16	21 ϕ /21 ϕ
DMA source address register_2	DSAR_2	32	H'FFC40	DMAC_2	16	21 ϕ /21 ϕ
DMA destination address register_2	DDAR_2	32	H'FFC44	DMAC_2	16	21 ϕ /21 ϕ
DMA offset register_2	DOFR_2	32	H'FFC48	DMAC_2	16	21 ϕ /21 ϕ
DMA transfer count register_2	DTCR_2	32	H'FFC4C	DMAC_2	16	21 ϕ /21 ϕ
DMA block size register_2	DBSR_2	32	H'FFC50	DMAC_2	16	21 ϕ /21 ϕ
DMA mode control register_2	DMDR_2	32	H'FFC54	DMAC_2	16	21 ϕ /21 ϕ
DMA address control register_2	DACR_2	32	H'FFC58	DMAC_2	16	21 ϕ /21 ϕ
DMA source address register_3	DSAR_3	32	H'FFC60	DMAC_3	16	21 ϕ /21 ϕ
DMA destination address register_3	DDAR_3	32	H'FFC64	DMAC_3	16	21 ϕ /21 ϕ
DMA offset register_3	DOFR_3	32	H'FFC68	DMAC_3	16	21 ϕ /21 ϕ
DMA transfer count register_3	DTCR_3	32	H'FFC6C	DMAC_3	16	21 ϕ /21 ϕ
DMA block size register_3	DBSR_3	32	H'FFC70	DMAC_3	16	21 ϕ /21 ϕ
DMA mode control register_3	DMDR_3	32	H'FFC74	DMAC_3	16	21 ϕ /21 ϕ
DMA address control register_3	DACR_3	32	H'FFC78	DMAC_3	16	21 ϕ /21 ϕ

Register Name	Abbreviation	Number of Bits	Address	Module	Data Width	Access Cycles (Read/Write)
DMA module request select register_0	DMRSR_0	8	H'FFD20	DMAC_0	16	21φ/21φ
DMA module request select register_1	DMRSR_1	8	H'FFD21	DMAC_1	16	21φ/21φ
DMA module request select register_2	DMRSR_2	8	H'FFD22	DMAC_2	16	21φ/21φ
DMA module request select register_3	DMRSR_3	8	H'FFD23	DMAC_3	16	21φ/21φ
Interrupt priority register A	IPRA	16	H'FFD40	INTC	16	21φ/31φ
Interrupt priority register B	IPRB	16	H'FFD42	INTC	16	21φ/31φ
Interrupt priority register C	IPRC	16	H'FFD44	INTC	16	21φ/31φ
Interrupt priority register D	IPRD	16	H'FFD46	INTC	16	21φ/31φ
Interrupt priority register E	IPRE	16	H'FFD48	INTC	16	21φ/31φ
Interrupt priority register F	IPRF	16	H'FFD4A	INTC	16	21φ/31φ
Interrupt priority register G	IPRG	16	H'FFD4C	INTC	16	21φ/31φ
Interrupt priority register H	IPRH	16	H'FFD4E	INTC	16	21φ/31φ
Interrupt priority register I	IPRI	16	H'FFD50	INTC	16	21φ/31φ
Interrupt priority register K	IPRK	16	H'FFD54	INTC	16	21φ/31φ
Interrupt priority register L	IPRL	16	H'FFD56	INTC	16	21φ/31φ
Interrupt priority register M	IPRM	16	H'FFD58	INTC	16	21φ/31φ
Interrupt priority register N	IPRN	16	H'FFD5A	INTC	16	21φ/31φ
Interrupt priority register O	IPRO	16	H'FFD5C	INTC	16	21φ/31φ
Interrupt priority register Q	IPRQ	16	H'FFD60	INTC	16	21φ/31φ
Interrupt priority register R	IPRR	16	H'FFD62	INTC	16	21φ/31φ
IRQ sense control register H	ISCRH	16	H'FFD68	INTC	16	21φ/31φ
IRQ sense control register L	ISCRL	16	H'FFD6A	INTC	16	21φ/31φ
DTC vector base register	DTCVBR	32	H'FFD80	BSC	16	21φ/31φ
Bus width control register	ABWCR	16	H'FFD84	BSC	16	21φ/31φ
Access state control register	ASTCR	16	H'FFD86	BSC	16	21φ/31φ
Wait control register A	WTCRA	16	H'FFD88	BSC	16	21φ/31φ
Wait control register B	WTCRB	16	H'FFD8A	BSC	16	21φ/31φ
Read strobe timing control register	RDNCR	16	H'FFD8C	BSC	16	21φ/31φ

Register Name	Abbreviation	Number of Bits	Address	Module	Data Width	Access Cycles (Read/Write)
\overline{CS} assertion period control register	CSACR	16	H'FFD8E	BSC	16	21 ϕ /31 ϕ
Idle control register	IDLCR	16	H'FFD90	BSC	16	21 ϕ /31 ϕ
Bus control register1	BCR1	16	H'FFD92	BSC	16	21 ϕ /31 ϕ
Bus control register2	BCR2	8	H'FFD94	BSC	16	21 ϕ /31 ϕ
Endian control register	ENDIANCR	8	H'FFD95	BSC	16	21 ϕ /31 ϕ
SRAM mode control register	SRAMCR	16	H'FFD98	BSC	16	21 ϕ /31 ϕ
Burst ROM interface control register	BROMCR	16	H'FFD9A	BSC	16	21 ϕ /31 ϕ
Address/data multiplexed I/O control register	MPXCR	16	H'FFD9C	BSC	16	21 ϕ /31 ϕ
RAM emulation register	RAMER	8	H'FFD9E	BSC	16	21 ϕ /31 ϕ
Mode control register	MDCR	16	H'FFDC0	SYSTEM	16	21 ϕ /31 ϕ
System control register	SYSCR	16	H'FFDC2	SYSTEM	16	21 ϕ /31 ϕ
System clock control register	SCKCR	16	H'FFDC4	SYSTEM	16	21 ϕ /31 ϕ
Standby control register	SBYCR	16	H'FFDC6	SYSTEM	16	21 ϕ /31 ϕ
Module stop control register A	MSTPCRA	16	H'FFDC8	SYSTEM	16	21 ϕ /31 ϕ
Module stop control register B	MSTPCRB	16	H'FFDCA	SYSTEM	16	21 ϕ /31 ϕ
Module stop control register C	MSTPCRC	16	H'FFDCC	SYSTEM	16	21 ϕ /31 ϕ
Flash code control/status register	FCCS	8	H'FFDE8	FLASH	16	21 ϕ /21 ϕ
Flash program code select register	FPCS	8	H'FFDE9	FLASH	16	21 ϕ /21 ϕ
Flash erase code select register	FECS	8	H'FFDEA	FLASH	16	21 ϕ /21 ϕ
Flash key code register	FKEY	8	H'FFDEC	FLASH	16	21 ϕ /21 ϕ
Flash MAT select register	FMATS	8	H'FFDED	FLASH	16	21 ϕ /21 ϕ
Flash transfer destination address register	FTDAR	8	H'FFDEE	FLASH	16	21 ϕ /21 ϕ
Deep standby control register	DPSBYCR	8	H'FFE70	SYSTEM	8	21 ϕ /31 ϕ
Deep standby wait control register	DPSWCR	8	H'FFE71	SYSTEM	8	21 ϕ /31 ϕ
Deep standby interrupt enable register	DPSIER	8	H'FFE72	SYSTEM	8	21 ϕ /31 ϕ
Deep standby interrupt flag register	DPSIFR	8	H'FFE73	SYSTEM	8	21 ϕ /31 ϕ
Deep standby interrupt edge register	DPSIEGR	8	H'FFE74	SYSTEM	8	21 ϕ /31 ϕ

Register Name	Abbreviation	Number of Bits	Address	Module	Data Width	Access Cycles (Read/Write)
Reset status register	RSTSR	8	H'FFE75	SYSTEM	8	21 ϕ /31 ϕ
Low voltage detection control register*2	LVDCR	8	H'FFE78	SYSTEM	8	21 ϕ /31 ϕ
Serial extended mode register_2	SEMR_2	8	H'FFE84	SCI_2	8	2P ϕ /2P ϕ
Serial mode register_3	SMR_3	8	H'FFE88	SCI_3	8	2P ϕ /2P ϕ
Bit rate register_3	BRR_3	8	H'FFE89	SCI_3	8	2P ϕ /2P ϕ
Serial control register_3	SCR_3	8	H'FFE8A	SCI_3	8	2P ϕ /2P ϕ
Transmit data register_3	TDR_3	8	H'FFE8B	SCI_3	8	2P ϕ /2P ϕ
Serial status register_3	SSR_3	8	H'FFE8C	SCI_3	8	2P ϕ /2P ϕ
Receive data register_3	RDR_3	8	H'FFE8D	SCI_3	8	2P ϕ /2P ϕ
Smart card mode register_3	SCMR_3	8	H'FFE8E	SCI_3	8	2P ϕ /2P ϕ
Serial control register_4	SMR_4	8	H'FFE90	SCI_4	8	2P ϕ /2P ϕ
Bit rate register_4	BRR_4	8	H'FFE91	SCI_4	8	2P ϕ /2P ϕ
Serial control register_4	SCR_4	8	H'FFE92	SCI_4	8	2P ϕ /2P ϕ
Transmit data register_4	TDR_4	8	H'FFE93	SCI_4	8	2P ϕ /2P ϕ
Serial status register_4	SSR_4	8	H'FFE94	SCI_4	8	2P ϕ /2P ϕ
Receive data register_4	RDR_4	8	H'FFE95	SCI_4	8	2P ϕ /2P ϕ
Smart card mode register_4	SCMR_4	8	H'FFE96	SCI_4	8	2P ϕ /2P ϕ
I ² C bus control register A_0	ICCRA_0	8	H'FFEB0	IIC2_0	8	2P ϕ /2P ϕ
I ² C bus control register B_0	ICCRB_0	8	H'FFEB1	IIC2_0	8	2P ϕ /2P ϕ
I ² C bus mode register_0	ICMR_0	8	H'FFEB2	IIC2_0	8	2P ϕ /2P ϕ
I ² C bus interrupt enable register_0	ICIER_0	8	H'FFEB3	IIC2_0	8	2P ϕ /2P ϕ
I ² C bus status register_0	ICSR_0	8	H'FFEB4	IIC2_0	8	2P ϕ /2P ϕ
Slave address register_0	SAR_0	8	H'FFEB5	IIC2_0	8	2P ϕ /2P ϕ
I ² C bus transmit data register_0	ICDRT_0	8	H'FFEB6	IIC2_0	8	2P ϕ /2P ϕ
I ² C bus receive data register_0	ICDRR_0	8	H'FFEB7	IIC2_0	8	2P ϕ /2P ϕ
I ² C bus control register A_1	ICCRA_1	8	H'FFEB8	IIC2_1	8	2P ϕ /2P ϕ
I ² C bus control register B_1	ICCRB_1	8	H'FFEB9	IIC2_1	8	2P ϕ /2P ϕ
I ² C bus mode register_1	ICMR_1	8	H'FFEBA	IIC2_1	8	2P ϕ /2P ϕ
I ² C bus interrupt enable register_1	ICIER_1	8	H'FFEBB	IIC2_1	8	2P ϕ /2P ϕ
I ² C bus status register_1	ICSR_1	8	H'FFEBC	IIC2_1	8	2P ϕ /2P ϕ

Register Name	Abbreviation	Number of Bits	Address	Module	Data Width	Access Cycles (Read/Write)
Slave address register_1	SAR_1	8	H'FFEBD	IIC2_1	8	2P ϕ /2P ϕ
I ² C bus transmit data register_1	ICDRT_1	8	H'FFEBE	IIC2_1	8	2P ϕ /2P ϕ
I ² C bus receive data register_1	ICDRR_1	8	H'FFEBF	IIC2_1	8	2P ϕ /2P ϕ
Timer control register_2	TCR_2	8	H'FFEC0	TMR_2	16	2P ϕ /2P ϕ
Timer control register_3	TCR_3	8	H'FFEC1	TMR_3	16	2P ϕ /2P ϕ
Timer control/status register_2	TCSR_2	8	H'FFEC2	TMR_2	16	2P ϕ /2P ϕ
Timer control/status register_3	TCSR_3	8	H'FFEC3	TMR_3	16	2P ϕ /2P ϕ
Time constant register A_2	TCORA_2	8	H'FFEC4	TMR_2	16	2P ϕ /2P ϕ
Time constant register A_3	TCORA_3	8	H'FFEC5	TMR_3	16	2P ϕ /2P ϕ
Time constant register B_2	TCORB_2	8	H'FFEC6	TMR_2	16	2P ϕ /2P ϕ
Time constant register B_3	TCORB_3	8	H'FFEC7	TMR_3	16	2P ϕ /2P ϕ
Timer counter_2	TCNT_2	8	H'FFEC8	TMR_2	16	2P ϕ /2P ϕ
Timer counter_3	TCNT_3	8	H'FFEC9	TMR_3	16	2P ϕ /2P ϕ
Timer counter control register_2	TCCR_2	8	H'FFECA	TMR_2	16	2P ϕ /2P ϕ
Timer counter control register_3	TCCR_3	8	H'FFECB	TMR_3	16	2P ϕ /2P ϕ
Timer control register_4	TCR_4	8	H'FFEE0	TPU_4	16	2P ϕ /2P ϕ
Timer mode register_4	TMDR_4	8	H'FFEE1	TPU_4	16	2P ϕ /2P ϕ
Timer I/O control register_4	TIOR_4	8	H'FFEE2	TPU_4	16	2P ϕ /2P ϕ
Timer interrupt enable register_4	TIER_4	8	H'FFEE4	TPU_4	16	2P ϕ /2P ϕ
Timer status register_4	TSR_4	8	H'FFEE5	TPU_4	16	2P ϕ /2P ϕ
Timer counter_4	TCNT_4	16	H'FFEE6	TPU_4	16	2P ϕ /2P ϕ
Timer general register A_4	TGRA_4	16	H'FFEE8	TPU_4	16	2P ϕ /2P ϕ
Timer general register B_4	TGRB_4	16	H'FFEEA	TPU_4	16	2P ϕ /2P ϕ
Timer control register_5	TCR_5	8	H'FFEF0	TPU_5	16	2P ϕ /2P ϕ
Timer mode register_5	TMDR_5	8	H'FFEF1	TPU_5	16	2P ϕ /2P ϕ
Timer I/O control register_5	TIOR_5	8	H'FFEF2	TPU_5	16	2P ϕ /2P ϕ
Timer interrupt enable register_5	TIER_5	8	H'FFEF4	TPU_5	16	2P ϕ /2P ϕ
Timer status register_5	TSR_5	8	H'FFEF5	TPU_5	16	2P ϕ /2P ϕ
Timer counter_5	TCNT_5	16	H'FFEF6	TPU_5	16	2P ϕ /2P ϕ
Timer general register A_5	TGRA_5	16	H'FFEF8	TPU_5	16	2P ϕ /2P ϕ
Timer general register B_5	TGRB_5	16	H'FFEFA	TPU_5	16	2P ϕ /2P ϕ

Register Name	Abbreviation	Number of Bits	Address	Module	Data Width	Access Cycles (Read/Write)
DTC enable register A	DTCERA	16	H'FFF20	INTC	16	21 ϕ /31 ϕ
DTC enable register B	DTCERB	16	H'FFF22	INTC	16	21 ϕ /31 ϕ
DTC enable register C	DTCERC	16	H'FFF24	INTC	16	21 ϕ /31 ϕ
DTC enable register D	DTCERD	16	H'FFF26	INTC	16	21 ϕ /31 ϕ
DTC enable register E	DTCERE	16	H'FFF28	INTC	16	21 ϕ /31 ϕ
DTC enable register F	DTCERF	16	H'FFF2A	INTC	16	21 ϕ /31 ϕ
DTC control register	DTCCR	8	H'FFF30	INTC	16	21 ϕ /31 ϕ
Interrupt control register	INTCR	8	H'FFF32	INTC	16	21 ϕ /31 ϕ
CPU priority control register	CPUPCR	8	H'FFF33	INTC	16	21 ϕ /31 ϕ
IRQ enable register	IER	16	H'FFF34	INTC	16	21 ϕ /31 ϕ
IRQ status register	ISR	16	H'FFF36	INTC	16	21 ϕ /31 ϕ
Port 1 register	PORT1	8	H'FFF40	I/O port	8	2P ϕ /-
Port 2 register	PORT2	8	H'FFF41	I/O port	8	2P ϕ /-
Port 3 register	PORT3	8	H'FFF42	I/O port	8	2P ϕ /-
Port 5 register	PORT5	8	H'FFF44	I/O port	8	2P ϕ /-
Port 6 register	PORT6	8	H'FFF45	I/O port	8	2P ϕ /-
Port A register	PORTA	8	H'FFF49	I/O port	8	2P ϕ /-
Port B register	PORTB	8	H'FFF4A	I/O port	8	2P ϕ /-
Port D register	PORTD	8	H'FFF4C	I/O port	8	2P ϕ /-
Port E register	PORTE	8	H'FFF4D	I/O port	8	2P ϕ /-
Port F register	PORTF	8	H'FFF4E	I/O port	8	2P ϕ /-
Port 1 data register	P1DR	8	H'FFF50	I/O port	8	2P ϕ /2P ϕ
Port 2 data register	P2DR	8	H'FFF51	I/O port	8	2P ϕ /2P ϕ
Port 3 data register	P3DR	8	H'FFF52	I/O port	8	2P ϕ /2P ϕ
Port 6 data register	P6DR	8	H'FFF55	I/O port	8	2P ϕ /2P ϕ
Port A data register	PADR	8	H'FFF59	I/O port	8	2P ϕ /2P ϕ
Port B data register	PBDR	8	H'FFF5A	I/O port	8	2P ϕ /2P ϕ
Port D data register	PDDR	8	H'FFF5C	I/O port	8	2P ϕ /2P ϕ
Port E data register	PEDR	8	H'FFF5D	I/O port	8	2P ϕ /2P ϕ
Port F data register	PFDR	8	H'FFF5E	I/O port	8	2P ϕ /2P ϕ
Serial mode register_2	SMR_2	8	H'FFF60	SCI_2	8	2P ϕ /2P ϕ

Register Name	Abbreviation	Number of Bits	Address	Module	Data Width	Access Cycles (Read/Write)
Bit rate register_2	BRR_2	8	H'FFF61	SCI_2	8	2P ϕ /2P ϕ
Serial control register_2	SCR_2	8	H'FFF62	SCI_2	8	2P ϕ /2P ϕ
Transmit data register_2	TDR_2	8	H'FFF63	SCI_2	8	2P ϕ /2P ϕ
Serial status register_2	SSR_2	8	H'FFF64	SCI_2	8	2P ϕ /2P ϕ
Receive data register_2	RDR_2	8	H'FFF65	SCI_2	8	2P ϕ /2P ϕ
Smart card mode register_2	SCMR_2	8	H'FFF66	SCI_2	8	2P ϕ /2P ϕ
D/A data register 0	DADR0	8	H'FFF68	D/A	8	2P ϕ /2P ϕ
D/A data register 1	DADR1	8	H'FFF69	D/A	8	2P ϕ /2P ϕ
D/A control register 01	DACR01	8	H'FFF6A	D/A	8	2P ϕ /2P ϕ
PPG output control register	PCR	8	H'FFF76	PPG_0	8	2P ϕ /2P ϕ
PPG output mode register	PMR	8	H'FFF77	PPG_0	8	2P ϕ /2P ϕ
Next data enable register H	NDERH	8	H'FFF78	PPG_0	8	2P ϕ /2P ϕ
Next data enable register L	NDERL	8	H'FFF79	PPG_0	8	2P ϕ /2P ϕ
Output data register H	PODRH	8	H'FFF7A	PPG_0	8	2P ϕ /2P ϕ
Output data register L	PODRL	8	H'FFF7B	PPG_0	8	2P ϕ /2P ϕ
Next data register H* ¹	NDRH	8	H'FFF7C	PPG_0	8	2P ϕ /2P ϕ
Next data register L* ¹	NDRL	8	H'FFF7D	PPG_0	8	2P ϕ /2P ϕ
Next data register H* ¹	NDRH	8	H'FFF7E	PPG_0	8	2P ϕ /2P ϕ
Next data register L* ¹	NDRL	8	H'FFF7F	PPG_0	8	2P ϕ /2P ϕ
Serial mode register_0	SMR_0	8	H'FFF80	SCI_0	8	2P ϕ /2P ϕ
Bit rate register_0	BRR_0	8	H'FFF81	SCI_0	8	2P ϕ /2P ϕ
Serial control register_0	SCR_0	8	H'FFF82	SCI_0	8	2P ϕ /2P ϕ
Transmit data register_0	TDR_0	8	H'FFF83	SCI_0	8	2P ϕ /2P ϕ
Serial status register_0	SSR_0	8	H'FFF84	SCI_0	8	2P ϕ /2P ϕ
Receive data register_0	RDR_0	8	H'FFF85	SCI_0	8	2P ϕ /2P ϕ
Smart card mode register_0	SCMR_0	8	H'FFF86	SCI_0	8	2P ϕ /2P ϕ
Serial mode register_1	SMR_1	8	H'FFF88	SCI_1	8	2P ϕ /2P ϕ
Bit rate register_1	BRR_1	8	H'FFF89	SCI_1	8	2P ϕ /2P ϕ
Serial control register_1	SCR_1	8	H'FFF8A	SCI_1	8	2P ϕ /2P ϕ
Transmit data register_1	TDR_1	8	H'FFF8B	SCI_1	8	2P ϕ /2P ϕ
Serial status register_1	SSR_1	8	H'FFF8C	SCI_1	8	2P ϕ /2P ϕ

Register Name	Abbreviation	Number of Bits	Address	Module	Data Width	Access Cycles (Read/Write)
Receive data register_1	RDR_1	8	H'FFF8D	SCI_1	8	2P ϕ /2P ϕ
Smart card mode register_1	SCMR_1	8	H'FFF8E	SCI_1	8	2P ϕ /2P ϕ
A/D data register A_0	ADDRA_0	16	H'FFF90	A/D_0	16	2P ϕ /2P ϕ
A/D data register B_0	ADDRB_0	16	H'FFF92	A/D_0	16	2P ϕ /2P ϕ
A/D data register C_0	ADDRC_0	16	H'FFF94	A/D_0	16	2P ϕ /2P ϕ
A/D data register D_0	ADDRD_0	16	H'FFF96	A/D_0	16	2P ϕ /2P ϕ
A/D data register E_0	ADDRE_0	16	H'FFF98	A/D_0	16	2P ϕ /2P ϕ
A/D data register F_0	ADDRF_0	16	H'FFF9A	A/D_0	16	2P ϕ /2P ϕ
A/D data register G_0	ADDRG_0	16	H'FFF9C	A/D_0	16	2P ϕ /2P ϕ
A/D data register H_0	ADDRH_0	16	H'FFF9E	A/D_0	16	2P ϕ /2P ϕ
A/D control/status register_0	ADCSR_0	8	H'FFFA0	A/D_0	16	2P ϕ /2P ϕ
A/D control register_0	ADCR_0	8	H'FFFA1	A/D_0	16	2P ϕ /2P ϕ
Timer control/status register	TCSR	8	H'FFFA4	WDT	16	2P ϕ /3P ϕ
Timer counter	TCNT	8	H'FFFA5	WDT	16	2P ϕ /3P ϕ
Reset control/status register	RSTCSR	8	H'FFFA7	WDT	16	2P ϕ /3P ϕ
Timer control register_0	TCR_0	8	H'FFFB0	TMR_0	16	2P ϕ /2P ϕ
Timer control register_1	TCR_1	8	H'FFFB1	TMR_1	16	2P ϕ /2P ϕ
Timer control/status register_0	TCSR_0	8	H'FFFB2	TMR_0	16	2P ϕ /2P ϕ
Timer control/status register_1	TCSR_1	8	H'FFFB3	TMR_1	16	2P ϕ /2P ϕ
Time constant register A_0	TCORA_0	8	H'FFFB4	TMR_0	16	2P ϕ /2P ϕ
Time constant register A_1	TCORA_1	8	H'FFFB5	TMR_1	16	2P ϕ /2P ϕ
Time constant register B_0	TCORB_0	8	H'FFFB6	TMR_0	16	2P ϕ /2P ϕ
Time constant register B_1	TCORB_1	8	H'FFFB7	TMR_1	16	2P ϕ /2P ϕ
Timer counter_0	TCNT_0	8	H'FFFB8	TMR_0	16	2P ϕ /2P ϕ
Timer counter_1	TCNT_1	8	H'FFFB9	TMR_1	16	2P ϕ /2P ϕ
Timer counter control register_0	TCCR_0	8	H'FFFBBA	TMR_0	16	2P ϕ /2P ϕ
Timer counter control register_1	TCCR_1	8	H'FFFBBB	TMR_1	16	2P ϕ /2P ϕ
Timer start register	TSTR	8	H'FFFBBC	TPU	16	2P ϕ /2P ϕ
Timer synchronous register	TSYR	8	H'FFFBBD	TPU	16	2P ϕ /2P ϕ
Timer control register_0	TCR_0	8	H'FFFC0	TPU_0	16	2P ϕ /2P ϕ
Timer mode register_0	TMDR_0	8	H'FFFC1	TPU_0	16	2P ϕ /2P ϕ

Register Name	Abbreviation	Number of Bits	Address	Module	Data Width	Access Cycles (Read/Write)
Timer I/O control register H_0	TIORH_0	8	H'FFFC2	TPU_0	16	2P ϕ /2P ϕ
Timer I/O control register L_0	TIORL_0	8	H'FFFC3	TPU_0	16	2P ϕ /2P ϕ
Timer interrupt enable register_0	TIER_0	8	H'FFFC4	TPU_0	16	2P ϕ /2P ϕ
Timer status register_0	TSR_0	8	H'FFFC5	TPU_0	16	2P ϕ /2P ϕ
Timer counter_0	TCNT_0	16	H'FFFC6	TPU_0	16	2P ϕ /2P ϕ
Timer general register A_0	TGRA_0	16	H'FFFC8	TPU_0	16	2P ϕ /2P ϕ
Timer general register B_0	TGRB_0	16	H'FFFC9	TPU_0	16	2P ϕ /2P ϕ
Timer general register C_0	TGRC_0	16	H'FFFCB	TPU_0	16	2P ϕ /2P ϕ
Timer general register D_0	TGRD_0	16	H'FFFCF	TPU_0	16	2P ϕ /2P ϕ
Timer control register_1	TCR_1	8	H'FFFD0	TPU_1	16	2P ϕ /2P ϕ
Timer mode register_1	TMDR_1	8	H'FFFD1	TPU_1	16	2P ϕ /2P ϕ
Timer I/O control register_1	TIOR_1	8	H'FFFD2	TPU_1	16	2P ϕ /2P ϕ
Timer interrupt enable register_1	TIER_1	8	H'FFFD4	TPU_1	16	2P ϕ /2P ϕ
Timer status register_1	TSR_1	8	H'FFFD5	TPU_1	16	2P ϕ /2P ϕ
Timer counter_1	TCNT_1	16	H'FFFD6	TPU_1	16	2P ϕ /2P ϕ
Timer general register A_1	TGRA_1	16	H'FFFD8	TPU_1	16	2P ϕ /2P ϕ
Timer general register B_1	TGRB_1	16	H'FFFDA	TPU_1	16	2P ϕ /2P ϕ
Timer control register_2	TCR_2	8	H'FFFE0	TPU_2	16	2P ϕ /2P ϕ
Timer mode register_2	TMDR_2	8	H'FFFE1	TPU_2	16	2P ϕ /2P ϕ
Timer I/O control register_2	TIOR_2	8	H'FFFE2	TPU_2	16	2P ϕ /2P ϕ
Timer interrupt enable register_2	TIER_2	8	H'FFFE4	TPU_2	16	2P ϕ /2P ϕ
Timer status register_2	TSR_2	8	H'FFFE5	TPU_2	16	2P ϕ /2P ϕ
Timer counter_2	TCNT_2	16	H'FFFE6	TPU_2	16	2P ϕ /2P ϕ
Timer general register A_2	TGRA_2	16	H'FFFE8	TPU_2	16	2P ϕ /2P ϕ
Timer general register B_2	TGRB_2	16	H'FFFEA	TPU_2	16	2P ϕ /2P ϕ
Timer control register_3	TCR_3	8	H'FFFF0	TPU_3	16	2P ϕ /2P ϕ
Timer mode register_3	TMDR_3	8	H'FFFF1	TPU_3	16	2P ϕ /2P ϕ
Timer I/O control register H_3	TIORH_3	8	H'FFFF2	TPU_3	16	2P ϕ /2P ϕ
Timer I/O control register L_3	TIORL_3	8	H'FFFF3	TPU_3	16	2P ϕ /2P ϕ
Timer interrupt enable register_3	TIER_3	8	H'FFFF4	TPU_3	16	2P ϕ /2P ϕ
Timer status register_3	TSR_3	8	H'FFFF5	TPU_3	16	2P ϕ /2P ϕ

Register Name	Abbreviation	Number of Bits	Address	Module	Data Width	Access Cycles (Read/Write)
Timer counter_3	TCNT_3	16	H'FFFF6	TPU_3	16	2P ϕ /2P ϕ
Timer general register A_3	TGRA_3	16	H'FFFF8	TPU_3	16	2P ϕ /2P ϕ
Timer general register B_3	TGRB_3	16	H'FFFFA	TPU_3	16	2P ϕ /2P ϕ
Timer general register C_3	TGRC_3	16	H'FFFFC	TPU_3	16	2P ϕ /2P ϕ
Timer general register D_3	TGRD_3	16	H'FFFFE	TPU_3	16	2P ϕ /2P ϕ

Notes: 1. When the same output trigger is specified for pulse output groups 2 and 3 by the PCR setting, the NDRH address is H'FFF7C. When different output triggers are specified, the NDRH addresses for pulse output groups 2 and 3 are H'FFF7E and H'FFF7C, respectively. Similarly, when the same output trigger is specified for pulse output groups 0 and 1 by the PCR setting, the NDRL address is H'FFF7D. When different output triggers are specified, the NDRL addresses for pulse output groups 0 and 1 are H'FFF7F and H'FFF7D, respectively.

When the same output trigger is specified for pulse output groups 6 and 7 by the PCR setting, the NDRH address is H'FF63C. When different output triggers are specified, the NDRH addresses for pulse output groups 6 and 7 are H'FF63E and H'FF63C, respectively.

When the same output trigger is specified for pulse output groups 4 and 5 by the PCR setting, the NDRL address is H'FF63D. When different output triggers are specified, the NDRL addresses for pulse output groups 4 and 5 are H'FF63F and H'FF63D, respectively.

2. Supported only by the H8SX/1638L Group.

26.2 Register Bits

Register addresses and bit names of the on-chip peripheral modules are described below.

Register Abbreviation	Bit 31/23/15/7	Bit 30/22/14/6	Bit 29/21/13/5	Bit 28/20/12/4	Bit 27/19/11/3	Bit 26/18/10/2	Bit 25/17/9/1	Bit 24/16/8/0	Module
TCR_4	CMIEB	CMIEA	OVIE	CCLR1	CCLR0	CKS2	CKS1	CKS0	TMR_4
TCR_5	CMIEB	CMIEA	OVIE	CCLR1	CCLR0	CKS2	CKS1	CKS0	TMR_5
TCSR_4	CMFB	CMFA	OVF	ADTE	OS3	OS2	OS1	OS0	TMR_4
TCSR_5	CMFB	CMFA	OVF	—	OS3	OS2	OS1	OS0	TMR_5
TCORA_4									TMR_4
TCORA_5									TMR_5
TCORB_4									TMR_4
TCORB_5									TMR_5
TCNT_4									TMR_4
TCNT_5									TMR_5
TCCR_4	—	—	—	—	TMRIS	—	ICKS1	ICKS0	TMR_4
TCCR_5	—	—	—	—	TMRIS	—	ICKS1	ICKS0	TMR_5
CRCCR	DORCLR	—	—	—	—	LMS	G1	G0	CRC
CRCDIR									
CRCDOR									
TCR_6	CMIEB	CMIEA	OVIE	CCLR1	CCLR0	CKS2	CKS1	CKS0	TMR_6
TCR_7	CMIEB	CMIEA	OVIE	CCLR1	CCLR0	CKS2	CKS1	CKS0	TMR_7
TCSR_6	CMFB	CMFA	OVF	ADTE	OS3	OS2	OS1	OS0	TMR_6
TCSR_7	CMFB	CMFA	OVF	—	OS3	OS2	OS1	OS0	TMR_7
TCORA_6									TMR_6
TCORA_7									TMR_7
TCORB_6									TMR_6
TCORB_7									TMR_7
TCNT_6									TMR_6
TCNT_7									TMR_7
TCCR_6	—	—	—	—	TMRIS	—	ICKS1	ICKS0	TMR_6
TCCR_7	—	—	—	—	TMRIS	—	ICKS1	ICKS0	TMR_7

Section 26 List of Registers

Register Abbreviation	Bit 31/23/15/7	Bit 30/22/14/6	Bit 29/21/13/5	Bit 28/20/12/4	Bit 27/19/11/3	Bit 26/18/10/2	Bit 25/17/9/1	Bit 24/16/8/0	Module
ADDRA_1									A/D_1
ADDRB_1									
ADDRC_1									
ADDRD_1									
ADDRE_1									
ADDRF_1									
ADDRG_1									
ADDRH_1									
ADCSR_1	ADF	ADIE	ADST	EXCKS	CH3	CH2	CH1	CH0	
ADCR_1	TRGS1	TRGS0	SCANE	SCANS	CKS1	CKS0	ADSTCLR	EXTRGS	
SMR_5*1	C/ \bar{A} (GM)	CHR (BLK)	PE (PE)	O/ \bar{E} (O/ \bar{E})	STOP (BCP1)	MP (BCP0)	CKS1	CKS0	SCI_5
BRR_5									
SCR_5*1	TIE	RIE	TE	RE	MPIE	TEIE	CKE1	CKE0	
TDR_5									
SSR_5*1	TDRE	RDRF	ORER	FER	PER	TEND	MPB	MPBT	
									(ERS)
RDR_5									
SCMR_5	—	—	—	—	SDIR	SINV	—	SMIF	
SEMR_5	—	—	—	ABCS	ACS3	ACS2	ACS1	ACS0	
IrCR	IrE	IrCKS2	IrCKS1	IrCKS0	IrTxINV	IrRxINV	—	—	
SMR_6*1	C/ \bar{A} (GM)	CHR (BLK)	PE (PE)	O/ \bar{E} (O/ \bar{E})	STOP (BCP1)	MP (BCP0)	CKS1	CKS0	SCI_6
BRR_6									

Register Abbreviation	Bit 31/23/15/7	Bit 30/22/14/6	Bit 29/21/13/5	Bit 28/20/12/4	Bit 27/19/11/3	Bit 26/18/10/2	Bit 25/17/9/1	Bit 24/16/8/0	Module
SCR_6* ¹	TIE	RIE	TE	RE	MPIE	TEIE	CKE1	CKE0	SCI_6
TDR_6									
SSR_6* ¹	TDRE	RDRF	ORER	FER	PER	TEND	MPB	MPBT	
				(ERS)					
RDR_6									
SCMR_6	—	—	—	—	SDIR	SINV	—	SMIF	
SEMR_6	—	—	—	ABCS	ACS3	ACS2	ACS1	ACS0	
PCR_1	G3CMS1	G3CMS0	G2CMS1	G2CMS0	G1CMS1	G1CMS0	G0CMS1	G0CMS0	PPG_1
PMR_1	G3INV	G2INV	G1INV	G0INV	G3NOV	G2NOV	G1NOV	G0NOV	
NDERH_1	NDER31	NDER30	NDER29	NDER28	NDER27	NDER26	NDER25	NDER24	
NDERL_1	NDER23	NDER22	NDER21	NDER20	NDER19	NDER18	NDER17	NDER16	
PODRH_1	POD31	POD30	POD29	POD28	POD27	POD26	POD25	POD24	
PODRL_1	POD23	POD22	POD21	POD20	POD19	POD18	POD17	POD16	
NDRH_1* ²	NDR31	NDR30	NDR29	NDR28	NDR27	NDR26	NDR25	NDR24	
NDRL_1* ²	NDR23	NDR22	NDR21	NDR20	NDR19	NDR18	NDR17	NDR16	
NDRH_1* ²	—	—	—	—	NDR27	NDR26	NDR25	NDR24	
NDRL_1* ²	—	—	—	—	NDR19	NDR18	NDR17	NDR16	
BARAH	BARA31	BARA30	BARA29	BARA28	BARA27	BARA26	BARA25	BARA24	UBC
	BARA23	BARA22	BARA21	BARA20	BARA19	BARA18	BARA17	BARA16	
BARAL	BARA15	BARA14	BARA13	BARA12	BARA11	BARA10	BARA9	BARA8	
	BARA7	BARA6	BARA5	BARA4	BARA3	BARA2	BARA1	BARA0	
BAMRAH	BAMRA31	BAMRA30	BAMRA29	BAMRA28	BAMRA27	BAMRA26	BAMRA25	BAMRA24	
	BAMRA23	BAMRA22	BAMRA21	BAMRA20	BAMRA19	BAMRA18	BAMRA17	BAMRA16	
BAMRAL	BAMRA15	BAMRA14	BAMRA13	BAMRA12	BAMRA11	BAMRA10	BAMRA9	BAMRA8	
	BAMRA7	BAMRA6	BAMRA5	BAMRA4	BAMRA3	BAMRA2	BAMRA1	BAMRA0	
BARBH	BARB31	BARB30	BARB29	BARB28	BARB27	BARB26	BARB25	BARB24	
	BARB23	BARB22	BARB21	BARB20	BARB19	BARB18	BARB17	BARB16	
BARBL	BARB15	BARB14	BARB13	BARB12	BARB11	BARB10	BARB9	BARB8	
	BARB7	BARB6	BARB5	BARB4	BARB3	BARB2	BARB1	BARB0	
BAMRBH	BAMRB31	BAMRB30	BAMRB29	BAMRB28	BAMRB27	BAMRB26	BAMRB25	BAMRB24	
	BAMRB23	BAMRB22	BAMRB21	BAMRB20	BAMRB19	BAMRB18	BAMRB17	BAMRB16	

Section 26 List of Registers

Register Abbreviation	Bit 31/23/15/7	Bit 30/22/14/6	Bit 29/21/13/5	Bit 28/20/12/4	Bit 27/19/11/3	Bit 26/18/10/2	Bit 25/17/9/1	Bit 24/16/8/0	Module
BAMRBL	BAMRB15	BAMRB14	BAMRB13	BAMRB12	BAMRB11	BAMRB10	BAMRB9	BAMRB8	UBC
	BAMRB7	BAMRB6	BAMRB5	BAMRB4	BAMRB3	BAMRB2	BAMRB1	BAMRB0	
BARCH	BARC31	BARC30	BARC29	BARC28	BARC27	BARC26	BARC25	BARC24	
	BARC23	BARC22	BARC21	BARC20	BARC19	BARC18	BARC17	BARC16	
BARCL	BARC15	BARC14	BARC13	BARC12	BARC11	BARC10	BARC9	BARC8	
	BARC7	BARC6	BARC5	BARC4	BARC3	BARC2	BARC1	BARC0	
BAMRCH	BAMRC31	BAMRC30	BAMRC29	BAMRC28	BAMRC27	BAMRC26	BAMRC25	BAMRC24	
	BAMRC23	BAMRC22	BAMRC21	BAMRC20	BAMRC19	BAMRC18	BAMRC17	BAMRC16	
BAMRCL	BAMRC15	BAMRC14	BAMRC13	BAMRC12	BAMRC11	BAMRC10	BAMRC9	BAMRC8	
	BAMRC7	BAMRC6	BAMRC5	BAMRC4	BAMRC3	BAMRC2	BAMRC1	BAMRC0	
BARDH	BARD31	BARD30	BARD29	BARD28	BARD27	BARD26	BARD25	BARD24	
	BARD23	BARD22	BARD21	BARD20	BARD19	BARD18	BARD17	BARD16	
BARDL	BARD15	BARD14	BARD13	BARD12	BARD11	BARD10	BARD9	BARD8	
	BARD7	BARD6	BARD5	BARD4	BARD3	BARD2	BARD1	BARD0	
BAMRDH	BAMRD31	BAMRD30	BAMRD29	BAMRD28	BAMRD27	BAMRD26	BAMRD25	BAMRD24	
	BAMRD23	BAMRD22	BAMRD21	BAMRD20	BAMRD19	BAMRD18	BAMRD17	BAMRD16	
BAMRDL	BAMRD15	BAMRD14	BAMRD13	BAMRD12	BAMRD11	BAMRD10	BAMRD9	BAMRD8	
	BAMRD7	BAMRD6	BAMRD5	BAMRD4	BAMRD3	BAMRD2	BAMRD1	BAMRD0	
BRCRA	—	—	CMFCPA	—	CPA2	CPA1	CPA0	—	
	—	—	IDA1	IDA0	RWA1	RWA0	—	—	
BRCRB	—	—	CMFCPB	—	CPB2	CPB1	CPB0	—	
	—	—	IDB1	IDB0	RWB1	RWB0	—	—	
BRCRC	—	—	CMFCPC	—	CPC2	CPC1	CPC0	—	
	—	—	IDC1	IDC0	RWC1	RWC0	—	—	
BRCRD	—	—	DMFCPD	—	CPD2	CPD1	CPD0	—	
	—	—	IDD1	IDD0	RWD1	RWD0	—	—	
TSTRB	—	—	CST5	CST4	CST3	CST2	CST1	CST0	TPU (unit 1)
TSYRB	—	—	SYNC5	SYNC4	SYNC3	SYNC2	SYNC1	SYNC0	
TCR_6	CCLR2	CCLR1	CCLR0	CKEG1	CKEG0	TPSC2	TPSC1	TPSC0	TPU_6
TMDR_6	—	—	BFB	BFA	MD3	MD2	MD1	MD0	
TIORH_6	IOB3	IOB2	IOB1	IOB0	IOA3	IOA2	IOA1	IOA0	
TIORL_6	IOD3	IOD2	IOD1	IOD0	IOC3	IOC2	IOC1	IOC0	

Register Abbreviation	Bit 31/23/15/7	Bit 30/22/14/6	Bit 29/21/13/5	Bit 28/20/12/4	Bit 27/19/11/3	Bit 26/18/10/2	Bit 25/17/9/1	Bit 24/16/8/0	Module	
TIER_6	—	—	—	TCIEV	TGIED	TGIEC	TGIEB	TGIEA	TPU_6	
TSR_6	—	—	—	TCFV	TGFD	TGFC	TGFB	TGFA		
TCNT_6	_____									
TGRA_6	_____									
TGRB_6	_____									
TGRC_6	_____									
TGRD_6	_____									
TCR_7	—	CCLR1	CCLR0	CKEG1	CKEG0	TPSC2	TPSC1	TPSC0		TPU_7
TMDR_7	—	—	—	—	MD3	MD2	MD1	MD0		
TIOR_7	IOB3	IOB2	IOB1	IOB0	IOA3	IOA2	IOA1	IOA0		
TIER_7	—	—	TCIEU	TCIEV	—	—	TGIEB	TGIEA		
TSR_7	TCFD	—	TCFU	TCFV	—	—	TGFB	TGFA		
TCNT_7	_____									
TGRA_7	_____									
TGRB_7	_____									
TCR_8	—	CCLR1	CCLR0	CKEG1	CKEG0	TPSC2	TPSC1	TPSC0	TPU_8	
TMDR_8	—	—	—	—	MD3	MD2	MD1	MD0		
TIOR_8	IOB3	IOB2	IOB1	IOB0	IOA3	IOA2	IOA1	IOA0		
TIER_8	—	—	TCIEU	TCIEV	—	—	TGIEB	TGIEA		
TSR_8	TCFD	—	TCFU	TCFV	—	—	TGFB	TGFA		
TCNT_8	_____									
TGRA_8	_____									

Register Abbreviation	Bit 31/23/15/7	Bit 30/22/14/6	Bit 29/21/13/5	Bit 28/20/12/4	Bit 27/19/11/3	Bit 26/18/10/2	Bit 25/17/9/1	Bit 24/16/8/0	Module
TGRB_8									TPU_8
TCR_9	CCLR2	CCLR1	CCLR0	CKEG1	CKEG0	TPSC2	TPSC1	TPSC0	TPU_9
TMDR_9	—	—	BFB	BFA	MD3	MD2	MD1	MD0	
TIORH_9	IOB3	IOB2	IOB1	IOB0	IOA3	IOA2	IOA1	IOA0	
TIORL_9	IOD3	IOD2	IOD1	IOD0	IOC3	IOC2	IOC1	IOC0	
TIER_9	—	—	—	TCIEV	TGIED	TGIEC	TGIEB	TGIEA	
TSR_9	—	—	—	TCFV	TGFD	TGFC	TGFB	TGFA	
TCNT_9									
TGRA_9									
TGRB_9									
TGRC_9									
TGRD_9									
TCR_10	—	CCLR1	CCLR0	CKEG1	CKEG0	TPSC2	TPSC1	TPSC0	TPU_10
TMDR_10	—	—	—	—	MD3	MD2	MD1	MD0	
TIOR_10	IOB3	IOB2	IOB1	IOB0	IOA3	IOA2	IOA1	IOA0	
TIER_10	—	—	TCIEU	TCIEV	—	—	TGIEB	TGIEA	
TSR_10	TCFD	—	TCFU	TCFV	—	—	TGFB	TGFA	
TCNT_10									
TGRA_10									
TGRB_10									
TCR_11	—	CCLR1	CCLR0	CKEG1	CKEG0	TPSC2	TPSC1	TPSC0	TPU_11
TMDR_11	—	—	—	—	MD3	MD2	MD1	MD0	
TIOR_11	IOB3	IOB2	IOB1	IOB0	IOA3	IOA2	IOA1	IOA0	

Register Abbreviation	Bit 31/23/15/7	Bit 30/22/14/6	Bit 29/21/13/5	Bit 28/20/12/4	Bit 27/19/11/3	Bit 26/18/10/2	Bit 25/17/9/1	Bit 24/16/8/0	Module
TIER_11	—	—	TCIEU	TCIEV	—	—	TGIEB	TGIEA	TPU_11
TSR_11	TCFD	—	TCFU	TCFV	—	—	TGFB	TGFA	
TCNT_11	_____								
TGRA_11	_____								
TGRB_11	_____								
P1DDR	P17DDR	P16DDR	P15DDR	P14DDR	P13DDR	P12DDR	P11DDR	P10DDR	I/O port
P2DDR	P27DDR	P26DDR	P25DDR	P24DDR	P23DDR	P22DDR	P21DDR	P20DDR	
P3DDR	P37DDR	P36DDR	P35DDR	P34DDR	P33DDR	P32DDR	P31DDR	P30DDR	
P6DDR	—	—	P65DDR	P64DDR	P63DDR	P62DDR	P61DDR	P60DDR	
PADDR	PA7DDR	PA6DDR	PA5DDR	PA4DDR	PA3DDR	PA2DDR	PA1DDR	PA0DDR	
PBDDR	—	—	—	—	PB3DDR	PB2DDR	PB1DDR	PB0DDR	
PDDDR	PD7DDR	PD6DDR	PD5DDR	PD4DDR	PD3DDR	PD2DDR	PD1DDR	PD0DDR	
PEDDR	PE7DDR	PE6DDR	PE5DDR	PE4DDR	PE3DDR	PE2DDR	PE1DDR	PE0DDR	
PFDDR	PF7DDR	PF6DDR	PF5DDR	PF4DDR	PF3DDR	PF2DDR	PF1DDR	PF0DDR	
P1ICR	P17ICR	P16ICR	P15ICR	P14ICR	P13ICR	P12ICR	P11ICR	P10ICR	
P2ICR	P27ICR	P26ICR	P25ICR	P24ICR	P23ICR	P22ICR	P21ICR	P20ICR	
P3ICR	P37ICR	P36ICR	P35ICR	P34ICR	P33ICR	P32ICR	P31ICR	P30ICR	
P5ICR	P57ICR	P56ICR	P55ICR	P54ICR	P53ICR	P52ICR	P51ICR	P50ICR	
P6ICR	—	—	P65ICR	P64ICR	P63ICR	P62ICR	P61ICR	P60ICR	
PAICR	PA7ICR	PA6ICR	PA5ICR	PA4ICR	PA3ICR	PA2ICR	PA1ICR	PA0ICR	
PBICR	—	—	—	—	PB3ICR	PB2ICR	PB1ICR	PB0ICR	
PDICR	PD7ICR	PD6ICR	PD5ICR	PD4ICR	PD3ICR	PD2ICR	PD1ICR	PD0ICR	
PEICR	PE7ICR	PE6ICR	PE5ICR	PE4ICR	PE3ICR	PE2ICR	PE1ICR	PE0ICR	
PFICR	PF7ICR	PF6ICR	PF5ICR	PF4ICR	PF3ICR	PF2ICR	PF1ICR	PF0ICR	
PORTH	PH7	PH6	PH5	PH4	PH3	PH2	PH1	PH0	
PORTI	PI7	PI6	PI5	PI4	PI3	PI2	PI1	PI0	
PORTJ	PJ7	PJ6	PJ5	PJ4	PJ3	PJ2	PJ1	PJ0	
PORTK	PK7	PK6	PK5	PK4	PK3	PK2	PK1	PK0	
PHDR	PH7DR	PH6DR	PH5DR	PH4DR	PH3DR	PH2DR	PH1DR	PH0DR	

Register Abbreviation	Bit 31/23/15/7	Bit 30/22/14/6	Bit 29/21/13/5	Bit 28/20/12/4	Bit 27/19/11/3	Bit 26/18/10/2	Bit 25/17/9/1	Bit 24/16/8/0	Module
PIDR	PI7DR	PI6DR	PI5DR	PI4DR	PI3DR	PI2DR	PI1DR	PI0DR	I/O port
PJDR	PJ7DR	PJ6DR	PJ5DR	PJ4DR	PJ3DR	PJ2DR	PJ1DR	PJ0DR	
PKDR	PK7DR	PK6DR	PK5DR	PK4DR	PK3DR	PK2DR	PK1DR	PK0DR	
PHDDR	PH7DDR	PH6DDR	PH5DDR	PH4DDR	PH3DDR	PH2DDR	PH1DDR	PH0DDR	
PIDDR	PI7DDR	PI6DDR	PI5DDR	PI4DDR	PI3DDR	PI2DDR	PI1DDR	PI0DDR	
PJDDR	PJ7DDR	PJ6DDR	PJ5DDR	PJ4DDR	PJ3DDR	PJ2DDR	PJ1DDR	PJ0DDR	
PKDDR	PK7DDR	PK6DDR	PK5DDR	PK4DDR	PK3DDR	PK2DDR	PK1DDR	PK0DDR	
PHICR	PH7ICR	PH6ICR	PH5ICR	PH4ICR	PH3ICR	PH2ICR	PH1ICR	PH0ICR	
PIICR	PI7ICR	PI6ICR	PI5ICR	PI4ICR	PI3ICR	PI2ICR	PI1ICR	PI0ICR	
PJICR	PJ7ICR	PJ6ICR	PJ5ICR	PJ4ICR	PJ3ICR	PJ2ICR	PJ1ICR	PJ0ICR	
PKICR	PK7ICR	PK6ICR	PK5ICR	PK4ICR	PK3ICR	PK2ICR	PK1ICR	PK0ICR	
PDPCR	PD7PCR	PD6PCR	PD5PCR	PD4PCR	PD3PCR	PD2PCR	PD1PCR	PD0PCR	
PEPCR	PE7PCR	PE6PCR	PE5PCR	PE4PCR	PE3PCR	PE2PCR	PE1PCR	PE0PCR	
PFPCR	PF7PCR	PF6PCR	PF5PCR	PF4PCR	PF3PCR	PF2PCR	PF1PCR	PF0PCR	
PHPCR	PH7PCR	PH6PCR	PH5PCR	PH4PCR	PH3PCR	PH2PCR	PH1PCR	PH0PCR	
PIPCR	PI7PCR	PI6PCR	PI5PCR	PI4PCR	PI3PCR	PI2PCR	PI1PCR	PI0PCR	
PJPCR	PJ7PCR	PJ6PCR	PJ5PCR	PJ4PCR	PJ3PCR	PJ2PCR	PJ1PCR	PJ0PCR	
PKPCR	PK7PCR	PK6PCR	PK5PCR	PK4PCR	PK3PCR	PK2PCR	PK1PCR	PK0PCR	
P2ODR	P27ODR	P26ODR	P25ODR	P24ODR	P23ODR	P22ODR	P21ODR	P20ODR	
PFODR	PF7ODR	PF6ODR	PF5ODR	PF4ODR	PF3ODR	PF2ODR	PF1ODR	PF0ODR	
PFCR0	CS7E	CS6E	CS5E	CS4E	CS3E	CS2E	CS1E	CS0E	
PFCR1	CS7SA	CS7SB	CS6SA	CS6SB	CS5SA	CS5SB	CS4SA	CS4SB	
PFCR2	—	CS2S	BSS	BSE	—	RDWRE	ASOE	—	
PFCR4	A23E	A22E	A21E	A20E	A19E	A18E	A17E	A16E	
PFCR6	—	LHWROE	—	—	TCLKS	—	—	—	
PFCR7	DMAS3A	DMAS3B	DMAS2A	DMAS2B	DMAS1A	DMAS1B	DMAS0A	DMAS0B	
PFCR9	TPUMS5	TPUMS4	TPUMS3A	TPUMS3B	TPUMS2	TPUMS1	TPUMS0A	TPUMS0B	
PFCRA	TPUMS11	TPUMS10	TPUMS9A	TPUMS9B	TPUMS8	TPUMS7	TPUMS6A	TPUMS6B	
PFCRB	—	ITS14*3	ITS13	ITS12	ITS11	ITS10	ITS9	ITS8	
PFCRC	ITS7	ITS6	ITS5	ITS4	ITS3	ITS2	ITS1	ITS0	
PFCRD	PCJKE	—	—	—	—	—	—	—	

Register Abbreviation	Bit 31/23/15/7	Bit 30/22/14/6	Bit 29/21/13/5	Bit 28/20/12/4	Bit 27/19/11/3	Bit 26/18/10/2	Bit 25/17/9/1	Bit 24/16/8/0	Module
SSIER	SSI15	SSI14	SSI13	SSI12	SSI11	SSI10	SSI9	SSI8	INTC
	SSI7	SSI6	SSI5	SSI4	SSI3	SSI2	SSI1	SSI0	
DPSBKR0	BKUP07	BKUP06	BKUP05	BKUP04	BKUP03	BKUP02	BKUP01	BKUP00	SYSTEM
DPSBKR1	BKUP17	BKUP16	BKUP15	BKUP14	BKUP13	BKUP12	BKUP11	BKUP10	
DPSBKR2	BKUP27	BKUP26	BKUP25	BKUP24	BKUP23	BKUP22	BKUP21	BKUP20	
DPSBKR3	BKUP37	BKUP36	BKUP35	BKUP34	BKUP33	BKUP32	BKUP31	BKUP30	
DPSBKR4	BKUP47	BKUP46	BKUP45	BKUP44	BKUP43	BKUP42	BKUP41	BKUP40	
DPSBKR5	BKUP57	BKUP56	BKUP55	BKUP54	BKUP53	BKUP52	BKUP51	BKUP50	
DPSBKR6	BKUP67	BKUP66	BKUP65	BKUP64	BKUP63	BKUP62	BKUP61	BKUP60	
DPSBKR7	BKUP77	BKUP76	BKUP75	BKUP74	BKUP73	BKUP72	BKUP71	BKUP70	
DPSBKR8	BKUP87	BKUP86	BKUP85	BKUP84	BKUP83	BKUP82	BKUP81	BKUP80	
DPSBKR9	BKUP97	BKUP96	BKUP95	BKUP94	BKUP93	BKUP92	BKUP91	BKUP90	
DPSBKR10	BKUP107	BKUP106	BKUP105	BKUP104	BKUP103	BKUP102	BKUP101	BKUP100	
DPSBKR11	BKUP117	BKUP116	BKUP115	BKUP114	BKUP113	BKUP112	BKUP111	BKUP110	
DPSBKR12	BKUP127	BKUP126	BKUP125	BKUP124	BKUP123	BKUP122	BKUP121	BKUP120	
DPSBKR13	BKUP137	BKUP136	BKUP135	BKUP134	BKUP133	BKUP132	BKUP131	BKUP130	
DPSBKR14	BKUP147	BKUP146	BKUP145	BKUP144	BKUP143	BKUP142	BKUP141	BKUP140	
DPSBKR15	BKUP157	BKUP156	BKUP155	BKUP154	BKUP153	BKUP152	BKUP151	BKUP150	
DSAR_0									DMAC_0
DDAR_0									
DOFR_0									

Register Abbreviation	Bit 31/23/15/7	Bit 30/22/14/6	Bit 29/21/13/5	Bit 28/20/12/4	Bit 27/19/11/3	Bit 26/18/10/2	Bit 25/17/9/1	Bit 24/16/8/0	Module
DTCR_0									DMAC_0
DBSR_0	BKSZH31	BKSZH30	BKSZH29	BKSZH28	BKSZH27	BKSZH26	BKSZH25	BKSZH24	
	BKSZH23	BKSZH22	BKSZH21	BKSZH20	BKSZH19	BKSZH18	BKSZH17	BKSZH16	
	BKSZ15	BKSZ14	BKSZ13	BKSZ12	BKSZ11	BKSZ10	BKSZ9	BKSZ8	
	BKSZ7	BKSZ6	BKSZ5	BKSZ4	BKSZ3	BKSZ2	BKSZ1	BKSZ0	
DMDR_0	DTE	DACKE	TENDE	—	DREQS	NRD	—	—	
	ACT	—	—	—	ERRF	—	ESIF	DTIF	
	DTSZ1	DTSZ0	MDS1	MDS0	TSEIE	—	ESIE	DTIE	
	DTF1	DTF0	DTA	—	—	DMAP2	DMAP1	DMAPO	
DACR_0	AMS	DIRS	—	—	—	RPTIE	ARS1	ARS0	
	—	—	SAT1	SAT0	—	—	DAT1	DAT0	
	SARIE	—	—	SARA4	SARA3	SARA2	SARA1	SARA0	
	DARIE	—	—	DARA4	DARA3	DARA2	DARA1	DARA0	
DSAR_1									DMAC_1
DDAR_1									
DOFR_1									
DTCR_1									

Register Abbreviation	Bit 31/23/15/7	Bit 30/22/14/6	Bit 29/21/13/5	Bit 28/20/12/4	Bit 27/19/11/3	Bit 26/18/10/2	Bit 25/17/9/1	Bit 24/16/8/0	Module
DBSR_1	BKSZH31	BKSZH30	BKSZH29	BKSZH28	BKSZH27	BKSZH26	BKSZH25	BKSZH24	DMAC_1
	BKSZH23	BKSZH22	BKSZH21	BKSZH20	BKSZH19	BKSZH18	BKSZH17	BKSZH16	
	BKSZ15	BKSZ14	BKSZ13	BKSZ12	BKSZ11	BKSZ10	BKSZ9	BKSZ8	
	BKSZ7	BKSZ6	BKSZ5	BKSZ4	BKSZ3	BKSZ2	BKSZ1	BKSZ0	
DMDR_1	DTE	DACKE	TENDE	—	DREQS	NRD	—	—	
	ACT	—	—	—	—	—	ESIF	DTIF	
	DTSZ1	DTSZ0	MDS1	MDS0	TSEIE	—	ESIE	DTIE	
	DTF1	DTF0	DTA	—	—	DMAP2	DMAP1	DMAP0	
DACR_1	AMS	DIRS	—	—	—	RPTIE	ARS1	ARS0	
	—	—	SAT1	SAT0	—	—	DAT1	DAT0	
	SARIE	—	—	SARA4	SARA3	SARA2	SARA1	SARA0	
	DARIE	—	—	DARA4	DARA3	DARA2	DARA1	DARA0	
DSAR_2								DMAC_2	
DDAR_2									
DOFR_2									
DTCR_2									
DBSR_2	BKSZH31	BKSZH30	BKSZH29	BKSZH28	BKSZH27	BKSZH26	BKSZH25	BKSZH24	
	BKSZH23	BKSZH22	BKSZH21	BKSZH20	BKSZH19	BKSZH18	BKSZH17	BKSZH16	
	BKSZ15	BKSZ14	BKSZ13	BKSZ12	BKSZ11	BKSZ10	BKSZ9	BKSZ8	
	BKSZ7	BKSZ6	BKSZ5	BKSZ4	BKSZ3	BKSZ2	BKSZ1	BKSZ0	

Register Abbreviation	Bit 31/23/15/7	Bit 30/22/14/6	Bit 29/21/13/5	Bit 28/20/12/4	Bit 27/19/11/3	Bit 26/18/10/2	Bit 25/17/9/1	Bit 24/16/8/0	Module
DMDR_2	DTE	DACKE	TENDE	—	DREQS	NRD	—	—	DMAC_2
	ACT	—	—	—	—	—	ESIF	DTIF	
	DTSZ1	DTSZ0	MDS1	MDS0	TSEIE	—	ESIE	DTIE	
	DTF1	DTF0	DTA	—	—	DMAP2	DMAP1	DMAPO	
DACR_2	AMS	DIRS	—	—	—	RPTIE	ARS1	ARS0	
	—	—	SAT1	SAT0	—	—	DAT1	DAT0	
	SARIE	—	—	SARA4	SARA3	SARA2	SARA1	SARA0	
	DARIE	—	—	DARA4	DARA3	DARA2	DARA1	DARA0	
DSAR_3								DMAC_3	
DDAR_3									
DOFR_3									
DTCR_3									
DBSR_3	BKSZH31	BKSZH30	BKSZH29	BKSZH28	BKSZH27	BKSZH26	BKSZH25	BKSZH24	
	BKSZH23	BKSZH22	BKSZH21	BKSZH20	BKSZH19	BKSZH18	BKSZH17	BKSZH16	
	BKSZ15	BKSZ14	BKSZ13	BKSZ12	BKSZ11	BKSZ10	BKSZ9	BKSZ8	
	BKSZ7	BKSZ6	BKSZ5	BKSZ4	BKSZ3	BKSZ2	BKSZ1	BKSZ0	
DMDR_3	DTE	DACKE	TENDE	—	DREQS	NRD	—	—	
	ACT	—	—	—	—	—	ESIF	DTIF	
	DTSZ1	DTSZ0	MDS1	MDS0	TSEIE	—	ESIE	DTIE	
	DTF1	DTF0	DTA	—	—	DMAP2	DMAP1	DMAPO	

Register Abbreviation	Bit 31/23/15/7	Bit 30/22/14/6	Bit 29/21/13/5	Bit 28/20/12/4	Bit 27/19/11/3	Bit 26/18/10/2	Bit 25/17/9/1	Bit 24/16/8/0	Module
DACR_3	AMS	DIRS	—	—	—	RPTIE	ARS1	ARS0	DMAC_3
	—	—	SAT1	SAT0	—	—	DAT1	DAT0	
	SARIE	—	—	SARA4	SARA3	SARA2	SARA1	SARA0	
	DARIE	—	—	DARA4	DARA3	DARA2	DARA1	DARA0	
DMRSR_0								DMAC_0	
DMRSR_1								DMAC_1	
DMRSR_2								DMAC_2	
DMRSR_3								DMAC_3	
IPRA	—	IPRA14	IPRA13	IPRA12	—	IPRA10	IPRA9	IPRA8	INTC
	—	IPRA6	IPRA5	IPRA4	—	IPRA2	IPRA1	IPRA0	
IPRB	—	IPRB14	IPRB13	IPRB12	—	IPRB10	IPRB9	IPRB8	
	—	IPRB6	IPRB5	IPRB4	—	IPRB2	IPRB1	IPRB0	
IPRC	—	IPRC14	IPRC13	IPRC12	—	IPRC10	IPRC9	IPRC8	
	—	IPRC6	IPRC5	IPRC4	—	IPRC2	IPRC1	IPRC0	
IPRD	—	IPRD14	IPRD13	IPRD12	—	IPRD10	IPRD9	IPRD8	
	—	IPRD6	IPRD5	IPRD4	—	IPRD2	IPRD1	IPRD0	
IPRE	—	—	—	—	—	IPRE10	IPRE9	IPRE8	
	—	—	—	—	—	—	—	—	
IPRF	—	—	—	—	—	IPRF10	IPRF9	IPRF8	
	—	IPRF6	IPRF5	IPRF4	—	IPRF2	IPRF1	IPRF0	
IPRG	—	IPRG14	IPRG13	IPRG12	—	IPRG10	IPRG9	IPRG8	
	—	IPRG6	IPRG5	IPRG4	—	IPRG2	IPRG1	IPRG0	
IPRH	—	IPRH14	IPRH13	IPRH12	—	IPRH10	IPRH9	IPRH8	
	—	IPRH6	IPRH5	IPRH4	—	IPRH2	IPRH1	IPRH0	
IPRI	—	IPRI14	IPRI13	IPRI12	—	IPRI10	IPRI9	IPRI8	
	—	IPRI6	IPRI5	IPRI4	—	IPRI2	IPRI1	IPRI0	
IPRK	—	IPRK14	IPRK13	IPRK12	—	—	—	—	
	—	IPRK6	IPRK5	IPRK4	—	IPRK2	IPRK1	IPRK0	
IPRL	—	IPRL14	IPRL13	IPRL12	—	IPRL10	IPRL9	IPRL8	
	—	IPRL6	IPRL5	IPRL4	—	IPRL2	IPRL1	IPRL0	

Register Abbreviation	Bit 31/23/15/7	Bit 30/22/14/6	Bit 29/21/13/5	Bit 28/20/12/4	Bit 27/19/11/3	Bit 26/18/10/2	Bit 25/17/9/1	Bit 24/16/8/0	Module
IPRM	—	IPRM14	IPRM13	IPRM12	—	IPRM10	IPRM9	IPRM8	INTC
	—	IPRM6	IPRM5	IPRM4	—	IPRM2	IPRM1	IPRM0	
IPRN	—	IPRN14	IPRN13	IPRN12	—	IPRN10	IPRN9	IPRN8	
	—	IPRN6	IPRN5	IPRN4	—	IPRN2	IPRN1	IPRN0	
IPRO	—	IPRO14	IPRO13	IPRO12	—	IPRO10	IPRO9	IPRO8	
	—	IPRO6	IPRO5	IPRO4	—	—	—	—	
IPRQ	—	—	—	—	—	—	—	—	
	—	IPRQ6	IPRQ5	IPRQ4	—	IPRQ2	IPRQ1	IPRQ0	
IPRR	—	IPRR14	IPRR13	IPRR12	—	IPRR10	IPRR9	IPRR8	
	—	—	—	—	—	IPRR2	IPRR1	IPRR0	
ISCRH	IRQ15SR	IRQ15SF	IRQ14SR	IRQ14SF	IRQ13SR	IRQ13SF	IRQ12SR	IRQ12SF	
	IRQ11SR	IRQ11SF	IRQ10SR	IRQ10SF	IRQ9SR	IRQ9SF	IRQ8SR	IRQ8SF	
ISCLR	IRQ7SR	IRQ7SF	IRQ6SR	IRQ6SF	IRQ5SR	IRQ5SF	IRQ4SR	IRQ4SF	
	IRQ3SR	IRQ3SF	IRQ2SR	IRQ2SF	IRQ1SR	IRQ1SF	IRQ0SR	IRQ0SF	
DTCVBR									BSC
ABWCR	ABWH7	ABWH6	ABWH5	ABWH4	ABWH3	ABWH2	ABWH1	ABWH0	
	ABWL7	ABWL6	ABWL5	ABWL4	ABWL3	ABWL2	ABWL1	ABWL0	
ASTCR	AST7	AST6	AST5	AST4	AST3	AST2	AST1	AST0	
	—	—	—	—	—	—	—	—	
WTCRA	—	W72	W71	W70	—	W62	W61	W60	
	—	W52	W51	W50	—	W42	W41	W40	
WTCRB	—	W32	W31	W30	—	W22	W21	W20	
	—	W12	W11	W10	—	W02	W01	W00	
RDNCR	RDN7	RDN6	RDN5	RDN4	RDN3	RDN2	RDN1	RDN0	
	—	—	—	—	—	—	—	—	
CSACR	CSXH7	CSXH6	CSXH5	CSXH4	CSXH3	CSXH2	CSXH1	CSXH0	
	CSXT7	CSXT6	CSXT5	CSXT4	CSXT3	CSXT2	CSXT1	CSXT0	

Register Abbreviation	Bit 31/23/15/7	Bit 30/22/14/6	Bit 29/21/13/5	Bit 28/20/12/4	Bit 27/19/11/3	Bit 26/18/10/2	Bit 25/17/9/1	Bit 24/16/8/0	Module
IDLCR	IDLS3	IDLS2	IDLS1	IDLS0	IDLCB1	IDLCB0	IDLCA1	IDLCA0	BSC
	IDLSEL7	IDLSEL6	IDLSEL5	IDLSEL4	IDLSEL3	IDLSEL2	IDLSEL1	IDLSEL0	
BCR1	BRLE	BREQOE	—	—	—	—	WDBE	WAITE	
	DKC	—	—	—	—	—	—	—	
BCR2	—	—	—	IBCCS	—	—	—	PWDBE	
ENDIANCR	LE7	LE6	LE5	LE4	LE3	LE2	—	—	
SRAMCR	BCSEL7	BCSEL6	BCSEL5	BCSEL4	BCSEL3	BCSEL2	BCSEL1	BCSEL0	
	—	—	—	—	—	—	—	—	
BROMCR	BSRM0	BSTS02	BSTS01	BSTS00	—	—	BSWD01	BSWD00	
	BSRM1	BSTS12	BSTS11	BSTS10	—	—	BSWD11	BSWD10	
MPXCR	MPXE7	MPXE6	MPXE5	MPXE4	MPXE3	—	—	—	
	—	—	—	—	—	—	—	ADDEX	
RAMER	—	—	—	—	RAMS	RAM2	RAM1	RAM0	
MDCR	—	—	—	—	MDS3	MDS2	MDS1	MDS0	SYSTEM
	—	—	—	—	—	—	—	—	
SYSCR	—	—	MACS	—	FETCHMD	—	EXPE	RAME	
	—	—	—	—	—	—	DTCMD	—	
SCKCR	PSTOP1	—	—	—	—	ICK2	ICK1	ICK0	
	—	PCK2	PCK1	PCK0	—	BCK2	BCK1	BCK0	
SBYCR	SSBY	OPE	—	STS4	STS3	STS2	STS1	STS0	
	SLPIE	—	—	—	—	—	—	—	
MSTPCRA	ACSE	MSTPA14	MSTPA13	MSTPA12	MSTPA11	MSTPA10	MSTPA9	MSTPA8	
	—	MSTPA7	MSTPA6	MSTPA5	MSTPA4	MSTPA3	MSTPA2	MSTPA1	
MSTPCRB	MSTPB15	MSTPB14	MSTPB13	MSTPB12	MSTPB11	MSTPB10	MSTPB9	MSTPB8	
	MSTPB7	MSTPB6	MSTPB5	MSTPB4	MSTPB3	MSTPB2	MSTPB1	MSTPB0	
MSTPCRC	MSTPC15	MSTPC14	MSTPC13	MSTPC12	—	MSTPC10	MSTPC9	MSTPC8	
	MSTPC7	MSTPC6	MSTPC5	MSTPC4	MSTPC3	MSTPC2	MSTPC1	MSTPC0	
FCCS	—	—	—	FLER	—	—	—	SCO	FLASH
FPCS	—	—	—	—	—	—	—	PPVS	
FECS	—	—	—	—	—	—	—	EPVB	

Section 26 List of Registers

Register Abbreviation	Bit 31/23/15/7	Bit 30/22/14/6	Bit 29/21/13/5	Bit 28/20/12/4	Bit 27/19/11/3	Bit 26/18/10/2	Bit 25/17/9/1	Bit 24/16/8/0	Module
FKEY	K7	K6	K5	K4	K3	K2	K1	K0	FLASH
FMATS	MS7	MS6	MS5	MS4	MS3	MS2	MS1	MS0	
FTDAR	TDER	TDA6	TDA5	TDA4	TDA3	TDA2	TDA1	TDA0	
DPSBYCR	DPSBY	IOKEEP	RAMCUT2	RAMCUT1	—	—	—	RAMCUT0	SYSTEM
DPSWCR	—	—	WTSTS5	WTSTS4	WTSTS3	WTSTS2	WTSTS1	WTSTS0	
DPSIER	—	—	—	—	DIRQ3E	DIRQ2E	DIRQ1E	DIRQ0E	
DPSIFR	DNMIF	—	—	—	DIRQ3F	DIRQ2F	DIRQ1F	DIRQ0F	
DPSIEGR	DNMIEG	—	—	—	DIRQ3EG	DIRQ2EG	DIRQ1EG	DIRQ0EG	
RSTSR	DPSRSTF	—	—	—	—	—	—	—	
LVDCR* ³	LVDE	LVDR1	—	LVDMON	—	—	—	—	
SEMR_2	—	—	—	—	ABCS	ACS2	ACS1	ACS0	SCI_2
SMR_3* ¹	C/ \bar{A} (GM)	CHR (BLK)	PE (PE)	O/ \bar{E} (O/ \bar{E})	STOP (BCP1)	MP (BCP0)	CKS1	CKS0	SCI_3
BRR_3									
SCR_3* ¹	TIE	RIE	TE	RE	MPIE	TEIE	CKE1	CKE0	
TDR_3									
SSR_3* ¹	TDRE	RDRF	ORER	FER (ERS)	PER	TEND	MPB	MPBT	
RDR_3									
SCMR_3	—	—	—	—	SDIR	SINV	—	SMIF	
SMR_4* ¹	C/ \bar{A} (GM)	CHR (BLK)	PE (PE)	O/ \bar{E} (O/ \bar{E})	STOP (BCP1)	MP (BCP0)	CKS1	CKS0	SCI_4
BRR_4									
SCR_4* ¹	TIE	RIE	TE	RE	MPIE	TEIE	CKE1	CKE0	
TDR_4									
SSR_4* ¹	TDRE	RDRF	ORER	FER (ERS)	PER	TEND	MPB	MPBT	
RDR_4									
SCMR_4	—	—	—	—	SDIR	SINV	—	SMIF	

Register Abbreviation	Bit 31/23/15/7	Bit 30/22/14/6	Bit 29/21/13/5	Bit 28/20/12/4	Bit 27/19/11/3	Bit 26/18/10/2	Bit 25/17/9/1	Bit 24/16/8/0	Module
ICCRA_0	ICE	RCVD	MST	TRS	CKS3	CKS2	CKS1	CKS0	IIC2_0
ICCRB_0	BBSY	SCP	SDAO	—	SCLO	—	IICRST	—	
ICMR_0	—	WAIT	—	—	BCWP	BC2	BC1	BC0	
ICIER_0	TIE	TEIE	RIE	NAKIE	STIE	ACKE	ACKBR	ACKBT	
ICSR_0	TDRE	TEND	RDRF	NACKF	STOP	AL	AAS	ADZ	
SAR_0	SVA6	SVA5	SVA4	SVA3	SVA2	SVA1	SVA0	—	
ICDRT_0									
ICDRR_0									
ICCRA_1	ICE	RCVD	MST	TRS	CKS3	CKS2	CKS1	CKS0	IIC2_1
ICCRB_1	BBSY	SCP	SDAO	—	SCLO	—	IICRST	—	
ICMR_1	—	WAIT	—	—	BCWP	BC2	BC1	BC0	
ICIER_1	TIE	TEIE	RIE	NAKIE	STIE	ACKE	ACKBR	ACKBT	
ICSR_1	TDRE	TEND	RDRF	NACKF	STOP	AL	AAS	ADZ	
SAR_1	SVA6	SVA5	SVA4	SVA3	SVA2	SVA1	SVA0	—	
ICDRT_1									
ICDRR_1									
TCR_2	CMIEB	CMIEA	OVIE	CCLR1	CCLR0	CKS2	CKS1	CKS0	TMR_2
TCR_3	CMIEB	CMIEA	OVIE	CCLR1	CCLR0	CKS2	CKS1	CKS0	TMR_3
TCSR_2	CMFB	CMFA	OVF	ADTE	OS3	OS2	OS1	OS0	TMR_2
TCSR_3	CMFB	CMFA	OVF	—	OS3	OS2	OS1	OS0	TMR_3
TCORA_2									TMR_2
TCORA_3									TMR_3
TCORB_2									TMR_2
TCORB_3									TMR_3
TCNT_2									TMR_2
TCNT_3									TMR_3
TCCR_2	—	—	—	—	TMRIS	—	ICKS1	ICKS0	TMR_2
TCCR_3	—	—	—	—	TMRIS	—	ICKS1	ICKS0	TMR_3

Register Abbreviation	Bit 31/23/15/7	Bit 30/22/14/6	Bit 29/21/13/5	Bit 28/20/12/4	Bit 27/19/11/3	Bit 26/18/10/2	Bit 25/17/9/1	Bit 24/16/8/0	Module
TCR_4	—	CCLR1	CCLR0	CKEG1	CKEG0	TPSC2	TPSC1	TPSC0	TPU_4
TMDR_4	—	—	—	—	MD3	MD2	MD1	MD0	
TIOR_4	IOB3	IOB2	IOB1	IOB0	IOA3	IOA2	IOA1	IOA0	
TIER_4	TTGE	—	TCIEU	TCIEV	—	—	TGIEB	TGIEA	
TSR_4	TCFD	—	TCFU	TCFV	—	—	TGFB	TGFA	
TCNT_4	_____								
TGRA_4	_____								
TGRB_4	_____								
TCR_5	—	CCLR1	CCLR0	CKEG1	CKEG0	TPSC2	TPSC1	TPSC0	TPU_5
TMDR_5	—	—	—	—	MD3	MD2	MD1	MD0	
TIOR_5	IOB3	IOB2	IOB1	IOB0	IOA3	IOA2	IOA1	IOA0	
TIER_5	TTGE	—	TCIEU	TCIEV	—	—	TGIEB	TGIEA	
TSR_5	TCFD	—	TCFU	TCFV	—	—	TGFB	TGFA	
TCNT_5	_____								
TGRA_5	_____								
TGRB_5	_____								
DTCERA	DTCEA15	DTCEA14	DTCEA13	DTCEA12	DTCEA11	DTCEA10	DTCEA9	DTCEA8	INTC
	DTCEA7	DTCEA6	DTCEA5	DTCEA4	DTCEA3	DTCEA2	DTCEA1	DTCEA0	
DTCERB	DTCEB15	—	DTCEB13	DTCEB12	DTCEB11	DTCEB10	DTCEB9	DTCEB8	
	DTCEB7	DTCEB6	DTCEB5	DTCEB4	DTCEB3	DTCEB2	DTCEB1	DTCEB0	
DTCERC	DTCEC15	DTCEC14	DTCEC13	DTCEC12	DTCEC11	DTCEC10	DTCEC9	DTCEC8	
	DTCEC7	DTCEC6	DTCEC5	DTCEC4	DTCEC3	DTCEC2	—	—	
DTCERD	—	—	DTCED13	DTCED12	DTCED11	DTCED10	—	—	
	—	—	DTCED5	DTCED4	DTCED3	DTCED2	DTCED1	DTCED0	

Register Abbreviation	Bit 31/23/15/7	Bit 30/22/14/6	Bit 29/21/13/5	Bit 28/20/12/4	Bit 27/19/11/3	Bit 26/18/10/2	Bit 25/17/9/1	Bit 24/16/8/0	Module
DTCERE	DTCEE15	DTCEE14	DTCEE13	DTCEE12	DTCEE11	DTCEE10	DTCEE9	DTCEE8	INTC
	DTCEE7	DTCEE6	DTCEE5	DTCEE4	DTCEE3	DTCEE2	DTCEE1	DTCEE0	
DTCERF	DTCEF15	DTCEF14	—	—	DTCEF11	DTCEF10	DTCEF9	—	
	—	—	—	—	—	—	—	—	
DTCCR	—	—	—	RRS	RCHNE	—	—	ERR	
INTCR	—	—	INTM1	INTM0	NMIEG	—	—	—	
CPUPCR	CPUPCE	DTCP2	DTCP1	DTCP0	IPSETE	CPUP2	CPUP1	CPUP0	
IER	IRQ15E	IRQ14E	IRQ13E	IRQ12E	IRQ11E	IRQ10E	IRQ9E	IRQ8E	
	IRQ7E	IRQ6E	IRQ5E	IRQ4E	IRQ3E	IRQ2E	IRQ1E	IRQ0E	
ISR	IRQ15F	IRQ14F	IRQ13F	IRQ12F	IRQ11F	IRQ10F	IRQ9F	IRQ8F	
	IRQ7F	IRQ6F	IRQ5F	IRQ4F	IRQ3F	IRQ2F	IRQ1F	IRQ0F	
PORT1	P17	P16	P15	P14	P13	P12	P11	P10	I/O port
PORT2	P27	P26	P25	P24	P23	P22	P21	P20	
PORT3	P37	P36	P35	P34	P33	P32	P31	P30	
PORT5	P57	P56	P55	P54	P53	P52	P51	P50	
PORT6	—	—	P65	P64	P63	P62	P61	P60	
PORTA	PA7	PA6	PA5	PA4	PA3	PA2	PA1	PA0	
PORTB	—	—	—	—	PB3	PB2	PB1	PB0	
PORTD	PD7	PD6	PD5	PD4	PD3	PD2	PD1	PD0	
PORTE	PE7	PE6	PE5	PE4	PE3	PE2	PE1	PE0	
PORTF	PF7	PF6	PF5	PF4	PF3	PF2	PF1	PF0	
P1DR	P17DR	P16DR	P15DR	P14DR	P13DR	P12DR	P11DR	P10DR	
P2DR	P27DR	P26DR	P25DR	P24DR	P23DR	P22DR	P21DR	P20DR	
P3DR	P37DR	P36DR	P35DR	P34DR	P33DR	P32DR	P31DR	P30DR	
P6DR	—	—	P65DR	P64DR	P63DR	P62DR	P61DR	P60DR	
PADR	PA7DR	PA6DR	PA5DR	PA4DR	PA3DR	PA2DR	PA1DR	PA0DR	
PBDR	—	—	—	—	PB3DR	PB2DR	PB1DR	PB0DR	
PDDR	PD7DR	PD6DR	PD5DR	PD4DR	PD3DR	PD2DR	PD1DR	PD0DR	
PEDR	PE7DR	PE6DR	PE5DR	PE4DR	PE3DR	PE2DR	PE1DR	PE0DR	
PFDR	PF7DR	PF6DR	PF5DR	PF4DR	PF3DR	PF2DR	PF1DR	PF0DR	

Section 26 List of Registers

Register Abbreviation	Bit 31/23/15/7	Bit 30/22/14/6	Bit 29/21/13/5	Bit 28/20/12/4	Bit 27/19/11/3	Bit 26/18/10/2	Bit 25/17/9/1	Bit 24/16/8/0	Module
SMR_2* ¹	C/ \bar{A} (GM)	CHR (BLK)	PE (PE)	O/ \bar{E} (O/ \bar{E})	STOP (BCP1)	MP (BCP0)	CKS1	CKS0	SCI_2
BRR_2									
SCR_2* ¹	TIE	RIE	TE	RE	MPIE	TEIE	CKE1	CKE0	
TDR_2									
SSR_2* ¹	TDRE	RDRF	ORER	FER (ERS)	PER	TEND	MPB	MPBT	
RDR_2									
SCMR_2	—	—	—	—	SDIR	SINV	—	SMIF	
DADR0									D/A
DADR1									
DACR01	DAOE1	DAOE0	DAE	—	—	—	—	—	
PCR	G3CMS1	G3CMS0	G2CMS1	G2CMS0	G1CMS1	G1CMS0	G0CMS1	G0CMS0	PPG_0
PMR	G3INV	G2INV	G1INV	G0INV	G3NOV	G2NOV	G1NOV	G0NOV	
NDERH	NDER15	NDER14	NDER13	NDER12	NDER11	NDER10	NDER9	NDER8	
NDERL	NDER7	NDER6	NDER5	NDER4	NDER3	NDER2	NDER1	NDER0	
PODRH	POD15	POD14	POD13	POD12	POD11	POD10	POD9	POD8	
PODRL	POD7	POD6	POD5	POD4	POD3	POD2	POD1	POD0	
NDRH* ²	NDR15	NDR14	NDR13	NDR12	NDR11	NDR10	NDR9	NDR8	
NDRL* ²	NDR7	NDR6	NDR5	NDR4	NDR3	NDR2	NDR1	NDR0	
NDRH* ²	—	—	—	—	NDR11	NDR10	NDR9	NDR8	
NDRL* ²	—	—	—	—	NDR3	NDR2	NDR1	NDR0	
SMR_0* ¹	C/ \bar{A} (GM)	CHR (BLK)	PE (PE)	O/ \bar{E} (O/ \bar{E})	STOP (BCP1)	MP (BCP0)	CKS1	CKS0	SCI_0
BRR_0									
SCR_0* ¹	TIE	RIE	TE	RE	MPIE	TEIE	CKE1	CKE0	
TDR_0									
SSR_0* ¹	TDRE	RDRF	ORER	FER (ERS)	PER	TEND	MPB	MPBT	
RDR_0									
SCMR_0	—	—	—	—	SDIR	SINV	—	SMIF	

Register Abbreviation	Bit 31/23/15/7	Bit 30/22/14/6	Bit 29/21/13/5	Bit 28/20/12/4	Bit 27/19/11/3	Bit 26/18/10/2	Bit 25/17/9/1	Bit 24/16/8/0	Module
SMR_1* ¹	C \bar{A} (GM)	CHR (BLK)	PE (PE)	O \bar{E} (O \bar{E})	STOP (BCP1)	MP (BCP0)	CKS1	CKS0	SCI_1
BRR_1									
SCR_1* ¹	TIE	RIE	TE	RE	MPIE	TEIE	CKE1	CKE0	
TDR_1									
SSR_1* ¹	TDRE	RDRF	ORER	FER (ERS)	PER	TEND	MPB	MPBT	
RDR_1									
SCMR_1	—	—	—	—	SDIR	SINV	—	SMIF	
ADDRA_0									A/D_0
ADDRB_0									
ADDRC_0									
ADDRD_0									
ADDRE_0									
ADDRF_0									
ADDRG_0									
ADDRH_0									
ADCSR_0	ADF	ADIE	ADST	—	CH3	CH2	CH1	CH0	
ADCR_0	TRGS1	TRGS0	SCANE	SCANS	CKS1	CKS0	—	EXTRGS	
TCSR	OVF	WT/ $\bar{I}T$	TME	—	—	CKS2	CKS1	CKS0	WDT
TCNT									
RSTCSR	WOVF	RSTE	—	—	—	—	—	—	
TCR_0	CMIEB	CMIEA	OVIE	CCLR1	CCLR0	CKS2	CKS1	CKS0	TMR_0
TCR_1	CMIEB	CMIEA	OVIE	CCLR1	CCLR0	CKS2	CKS1	CKS0	TMR_1

Section 26 List of Registers

Register Abbreviation	Bit 31/23/15/7	Bit 30/22/14/6	Bit 29/21/13/5	Bit 28/20/12/4	Bit 27/19/11/3	Bit 26/18/10/2	Bit 25/17/9/1	Bit 24/16/8/0	Module
TCSR_0	CMFB	CMFA	OVF	ADTE	OS3	OS2	OS1	OS0	TMR_0
TCSR_1	CMFB	CMFA	OVF	—	OS3	OS2	OS1	OS0	TMR_1
TCORA_0									TMR_0
TCORA_1									TMR_1
TCORB_0									TMR_0
TCORB_1									TMR_1
TCNT_0									TMR_0
TCNT_1									TMR_1
TCCR_0	—	—	—	—	TMRIS	—	ICKS1	ICKS0	TMR_0
TCCR_1	—	—	—	—	TMRIS	—	ICKS1	ICKS0	TMR_1
TSTR	—	—	CST5	CST4	CST3	CST2	CST1	CST0	TPU
TSYR	—	—	SYNC5	SYNC4	SYNC3	SYNC2	SYNC1	SYNC0	
TCR_0	CCLR2	CCLR1	CCLR0	CKEG1	CKEG0	TPSC2	TPSC1	TPSC0	TPU_0
TMDR_0	—	—	BFB	BFA	MD3	MD2	MD1	MD0	
TIORH_0	IOB3	IOB2	IOB1	IOB0	IOA3	IOA2	IOA1	IOA0	
TIORL_0	IOD3	IOD2	IOD1	IOD0	IOC3	IOC2	IOC1	IOC0	
TIER_0	TTGE	—	—	TCIEV	TGIED	TGIEC	TGIEB	TGIEA	
TSR_0	—	—	—	TCFV	TGFD	TGFC	TGFB	TGFA	
TCNT_0									
TGRA_0									
TGRB_0									
TGRC_0									
TGRD_0									

Register Abbreviation	Bit 31/23/15/7	Bit 30/22/14/6	Bit 29/21/13/5	Bit 28/20/12/4	Bit 27/19/11/3	Bit 26/18/10/2	Bit 25/17/9/1	Bit 24/16/8/0	Module
TCR_1	—	CCLR1	CCLR0	CKEG1	CKEG0	TPSC2	TPSC1	TPSC0	TPU_1
TMDR_1	—	—	—	—	MD3	MD2	MD1	MD0	
TIOR_1	IOB3	IOB2	IOB1	IOB0	IOA3	IOA2	IOA1	IOA0	
TIER_1	TTGE	—	TCIEU	TCIEV	—	—	TGIEB	TGIEA	
TSR_1	TCFD	—	TCFU	TCFV	—	—	TGFB	TGFA	
TCNT_1	_____								
TGRA_1	_____								
TGRB_1	_____								
TCR_2	—	CCLR1	CCLR0	CKEG1	CKEG0	TPSC2	TPSC1	TPSC0	TPU_2
TMDR_2	—	—	—	—	MD3	MD2	MD1	MD0	
TIOR_2	IOB3	IOB2	IOB1	IOB0	IOA3	IOA2	IOA1	IOA0	
TIER_2	TTGE	—	TCIEU	TCIEV	—	—	TGIEB	TGIEA	
TSR_2	TCFD	—	TCFU	TCFV	—	—	TGFB	TGFA	
TCNT_2	_____								
TGRA_2	_____								
TGRB_2	_____								
TCR_3	CCLR2	CCLR1	CCLR0	CKEG1	CKEG0	TPSC2	TPSC1	TPSC0	TPU_3
TMDR_3	—	—	BFB	BFA	MD3	MD2	MD1	MD0	
TIORH_3	IOB3	IOB2	IOB1	IOB0	IOA3	IOA2	IOA1	IOA0	
TIORL_3	IOD3	IOD2	IOD1	IOD0	IOC3	IOC2	IOC1	IOC0	
TIER_3	TTGE	—	—	TCIEV	TGIED	TGIEC	TGIEB	TGIEA	
TSR_3	—	—	—	TCFV	TGFD	TGFC	TGFB	TGFA	
TCNT_3	_____								

Register Abbreviation	Bit 31/23/15/7	Bit 30/22/14/6	Bit 29/21/13/5	Bit 28/20/12/4	Bit 27/19/11/3	Bit 26/18/10/2	Bit 25/17/9/1	Bit 24/16/8/0	Module
TGRA_3	_____								TPU_3
TGRB_3	_____								
TGRC_3	_____								
TGRD_3	_____								

Each line covers eight bits, and 16-bit and 32-bit registers are shown as 2 or 4 lines, respectively.

- Notes:
- Parts of the bit functions differ in normal mode and the smart card interface.
 - When the same output trigger is specified for pulse output groups 2 and 3 by the PCR setting, the NDRH address is H'FFF7C. When different output triggers are specified, the NDRH addresses for pulse output groups 2 and 3 are H'FFF7E and H'FFF7C, respectively. Similarly, when the same output trigger is specified for pulse output groups 0 and 1 by the PCR setting, the NDRL address is H'FFF7D. When different output triggers are specified, the NDRL addresses for pulse output groups 0 and 1 are H'FFF7F and H'FFF7D, respectively.
 When the same output trigger is specified for pulse output groups 6 and 7 by the PCR setting, the NDRH address is H'FF63C. When different output triggers are specified, the NDRH addresses for pulse output groups 6 and 7 are H'FF63E and H'FF63C, respectively.
 When the same output trigger is specified for pulse output groups 4 and 5 by the PCR setting, the NDRL address is H'FF63D. When different output triggers are specified, the NDRL addresses for pulse output groups 4 and 5 are H'FF63F and H'FF63D, respectively.
 - Supported only by the H8SX/1638L Group.

26.3 Register States in Each Operating Mode

Register Abbreviation	Reset	Module Stop State	Sleep Mode	All-Module- Clock-Stop Mode	Software Standby Mode	Deep Software Standby Mode	Hardware Standby Mode	Module
TCR_4	Initialized	—	—	—	—	Initialized* ¹	Initialized	TMR_4
TCR_5	Initialized	—	—	—	—	Initialized* ¹	Initialized	TMR_5
TCSR_4	Initialized	—	—	—	—	Initialized* ¹	Initialized	TMR_4
TCSR_5	Initialized	—	—	—	—	Initialized* ¹	Initialized	TMR_5
TCORA_4	Initialized	—	—	—	—	Initialized* ¹	Initialized	TMR_4
TCORA_5	Initialized	—	—	—	—	Initialized* ¹	Initialized	TMR_5
TCORB_4	Initialized	—	—	—	—	Initialized* ¹	Initialized	TMR_4
TCORB_5	Initialized	—	—	—	—	Initialized* ¹	Initialized	TMR_5
TCNT_4	Initialized	—	—	—	—	Initialized* ¹	Initialized	TMR_4
TCNT_5	Initialized	—	—	—	—	Initialized* ¹	Initialized	TMR_5
TCCR_4	Initialized	—	—	—	—	Initialized* ¹	Initialized	TMR_4
TCCR_5	Initialized	—	—	—	—	Initialized* ¹	Initialized	TMR_5
CRCCR	Initialized	—	—	—	—	Initialized* ¹	Initialized	CRC
CRCDIR	Initialized	—	—	—	—	Initialized* ¹	Initialized	
CRCDOR	Initialized	—	—	—	—	Initialized* ¹	Initialized	
TCR_6	Initialized	—	—	—	—	Initialized* ¹	Initialized	TMR_6
TCR_7	Initialized	—	—	—	—	Initialized* ¹	Initialized	TMR_7
TCSR_6	Initialized	—	—	—	—	Initialized* ¹	Initialized	TMR_6
TCSR_7	Initialized	—	—	—	—	Initialized* ¹	Initialized	TMR_7
TCORA_6	Initialized	—	—	—	—	Initialized* ¹	Initialized	TMR_6
TCORA_7	Initialized	—	—	—	—	Initialized* ¹	Initialized	TMR_7
TCORB_6	Initialized	—	—	—	—	Initialized* ¹	Initialized	TMR_6
TCORB_7	Initialized	—	—	—	—	Initialized* ¹	Initialized	TMR_7
TCNT_6	Initialized	—	—	—	—	Initialized* ¹	Initialized	TMR_6
TCNT_7	Initialized	—	—	—	—	Initialized* ¹	Initialized	TMR_7
TCCR_6	Initialized	—	—	—	—	Initialized* ¹	Initialized	TMR_6
TCCR_7	Initialized	—	—	—	—	Initialized* ¹	Initialized	TMR_7
ADDRA_1	Initialized	—	—	—	—	Initialized* ¹	Initialized	A/D_1
ADDRB_1	Initialized	—	—	—	—	Initialized* ¹	Initialized	

Register Abbreviation	Reset	Module Stop State	Sleep Mode	All-Module- Clock-Stop Mode	Software Standby Mode	Deep Software Standby Mode	Hardware Standby Mode	Module
ADDRC_1	Initialized	—	—	—	—	Initialized* ¹	Initialized	A/D_1
ADDRD_1	Initialized	—	—	—	—	Initialized* ¹	Initialized	
ADDRE_1	Initialized	—	—	—	—	Initialized* ¹	Initialized	
ADDRF_1	Initialized	—	—	—	—	Initialized* ¹	Initialized	
ADDRG_1	Initialized	—	—	—	—	Initialized* ¹	Initialized	
ADDRH_1	Initialized	—	—	—	—	Initialized* ¹	Initialized	
ADCSR_1	Initialized	—	—	—	—	Initialized* ¹	Initialized	
ADCR_1	Initialized	—	—	—	—	Initialized* ¹	Initialized	
SMR_5	Initialized	—	—	—	—	Initialized* ¹	Initialized	SCI_5
BRR_5	Initialized	—	—	—	—	Initialized* ¹	Initialized	
SCR_5	Initialized	—	—	—	—	Initialized* ¹	Initialized	
TDR_5	Initialized	Initialized	—	Initialized	Initialized	Initialized* ¹	Initialized	
SSR_5	Initialized	Initialized	—	Initialized	Initialized	Initialized* ¹	Initialized	
RDR_5	Initialized	Initialized	—	Initialized	Initialized	Initialized* ¹	Initialized	
SCMR_5	Initialized	—	—	—	—	Initialized* ¹	Initialized	
SEMR_5	Initialized	—	—	—	—	Initialized* ¹	Initialized	
IrCR	Initialized	—	—	—	—	Initialized* ¹	Initialized	
SMR_6	Initialized	—	—	—	—	Initialized* ¹	Initialized	SCI_6
BRR_6	Initialized	—	—	—	—	Initialized* ¹	Initialized	
SCR_6	Initialized	—	—	—	—	Initialized* ¹	Initialized	
TDR_6	Initialized	Initialized	—	Initialized	Initialized	Initialized* ¹	Initialized	
SSR_6	Initialized	Initialized	—	Initialized	Initialized	Initialized* ¹	Initialized	
RDR_6	Initialized	Initialized	—	Initialized	Initialized	Initialized* ¹	Initialized	
SCMR_6	Initialized	—	—	—	—	Initialized* ¹	Initialized	
SEMR_6	Initialized	—	—	—	—	Initialized* ¹	Initialized	
PCR_1	Initialized	—	—	—	—	Initialized* ¹	Initialized	PPG
PMR_1	Initialized	—	—	—	—	Initialized* ¹	Initialized	
NDERH_1	Initialized	—	—	—	—	Initialized* ¹	Initialized	
NDERL_1	Initialized	—	—	—	—	Initialized* ¹	Initialized	
PODRH_1	Initialized	—	—	—	—	Initialized* ¹	Initialized	
PODRL_1	Initialized	—	—	—	—	Initialized* ¹	Initialized	

Register Abbreviation	Reset	Module Stop State	Sleep Mode	All-Module- Clock-Stop Mode	Software Standby Mode	Deep Software Standby Mode	Hardware Standby Mode	Module
NDRH_1	Initialized	—	—	—	—	Initialized* ¹	Initialized	PPG
NDRL_1	Initialized	—	—	—	—	Initialized* ¹	Initialized	
BARAH	Initialized	—	—	—	—	Initialized* ¹	Initialized*	UBC
BARAL	Initialized	—	—	—	—	Initialized* ¹	Initialized*	
BAMRAH	Initialized	—	—	—	—	Initialized* ¹	Initialized*	
BAMRAL	Initialized	—	—	—	—	Initialized* ¹	Initialized*	
BARBH	Initialized	—	—	—	—	Initialized* ¹	Initialized*	
BARBL	Initialized	—	—	—	—	Initialized* ¹	Initialized*	
BAMRBH	Initialized	—	—	—	—	Initialized* ¹	Initialized*	
BAMRBL	Initialized	—	—	—	—	Initialized* ¹	Initialized*	
BARCH	Initialized	—	—	—	—	Initialized* ¹	Initialized*	
BARCL	Initialized	—	—	—	—	Initialized* ¹	Initialized*	
BAMRCH	Initialized	—	—	—	—	Initialized* ¹	Initialized*	
BAMRCL	Initialized	—	—	—	—	Initialized* ¹	Initialized*	
BARDH	Initialized	—	—	—	—	Initialized* ¹	Initialized*	
BARDL	Initialized	—	—	—	—	Initialized* ¹	Initialized*	
BAMRDH	Initialized	—	—	—	—	Initialized* ¹	Initialized*	
BAMRDL	Initialized	—	—	—	—	Initialized* ¹	Initialized*	
BRCRA	Initialized	—	—	—	—	Initialized* ¹	Initialized*	
BRCRB	Initialized	—	—	—	—	Initialized* ¹	Initialized*	
BRCRC	Initialized	—	—	—	—	Initialized* ¹	Initialized*	
BRCRD	Initialized	—	—	—	—	Initialized* ¹	Initialized*	
TSTRB	Initialized	—	—	—	—	Initialized* ¹	Initialized	TPU
TSYRB	Initialized	—	—	—	—	Initialized* ¹	Initialized	(unit 1)
TCR_6	Initialized	—	—	—	—	Initialized* ¹	Initialized	TPU_6
TMDR_6	Initialized	—	—	—	—	Initialized* ¹	Initialized	
TIORH_6	Initialized	—	—	—	—	Initialized* ¹	Initialized	
TIORL_6	Initialized	—	—	—	—	Initialized* ¹	Initialized	
TIER_6	Initialized	—	—	—	—	Initialized* ¹	Initialized	
TSR_6	Initialized	—	—	—	—	Initialized* ¹	Initialized	
TCNT_6	Initialized	—	—	—	—	Initialized* ¹	Initialized	

Register Abbreviation	Reset	Module Stop State	Sleep Mode	All-Module- Clock-Stop Mode	Software Standby Mode	Deep Software Standby Mode	Hardware Standby Mode	Module
TGRA_6	Initialized	—	—	—	—	Initialized* ¹	Initialized	TPU_6
TGRB_6	Initialized	—	—	—	—	Initialized* ¹	Initialized	
TGRC_6	Initialized	—	—	—	—	Initialized* ¹	Initialized	
TGRD_6	Initialized	—	—	—	—	Initialized* ¹	Initialized	
TCR_7	Initialized	—	—	—	—	Initialized* ¹	Initialized	TPU_7
TMDR_7	Initialized	—	—	—	—	Initialized* ¹	Initialized	
TIOR_7	Initialized	—	—	—	—	Initialized* ¹	Initialized	
TIER_7	Initialized	—	—	—	—	Initialized* ¹	Initialized	
TSR_7	Initialized	—	—	—	—	Initialized* ¹	Initialized	
TCNT_7	Initialized	—	—	—	—	Initialized* ¹	Initialized	
TGRA_7	Initialized	—	—	—	—	Initialized* ¹	Initialized	
TGRB_7	Initialized	—	—	—	—	Initialized* ¹	Initialized	
TCR_8	Initialized	—	—	—	—	Initialized* ¹	Initialized	TPU_8
TMDR_8	Initialized	—	—	—	—	Initialized* ¹	Initialized	
TIOR_8	Initialized	—	—	—	—	Initialized* ¹	Initialized	
TIER_8	Initialized	—	—	—	—	Initialized* ¹	Initialized	
TSR_8	Initialized	—	—	—	—	Initialized* ¹	Initialized	
TCNT_8	Initialized	—	—	—	—	Initialized* ¹	Initialized	
TGRA_8	Initialized	—	—	—	—	Initialized* ¹	Initialized	
TGRB_8	Initialized	—	—	—	—	Initialized* ¹	Initialized	
TCR_9	Initialized	—	—	—	—	Initialized* ¹	Initialized	TPU_9
TMDR_9	Initialized	—	—	—	—	Initialized* ¹	Initialized	
TIORH_9	Initialized	—	—	—	—	Initialized* ¹	Initialized	
TIORL_9	Initialized	—	—	—	—	Initialized* ¹	Initialized	
TIER_9	Initialized	—	—	—	—	Initialized* ¹	Initialized	
TSR_9	Initialized	—	—	—	—	Initialized* ¹	Initialized	
TCNT_9	Initialized	—	—	—	—	Initialized* ¹	Initialized	
TGRA_9	Initialized	—	—	—	—	Initialized* ¹	Initialized	
TGRB_9	Initialized	—	—	—	—	Initialized* ¹	Initialized	
TGRC_9	Initialized	—	—	—	—	Initialized* ¹	Initialized	
TGRD_9	Initialized	—	—	—	—	Initialized* ¹	Initialized	

Register Abbreviation	Reset	Module Stop State	Sleep Mode	All-Module- Clock-Stop Mode	Software Standby Mode	Deep Software Standby Mode	Hardware Standby Mode	Module
TCR_10	Initialized	—	—	—	—	Initialized* ¹	Initialized	TPU_10
TMDR_10	Initialized	—	—	—	—	Initialized* ¹	Initialized	
TIOR_10	Initialized	—	—	—	—	Initialized* ¹	Initialized	
TIER_10	Initialized	—	—	—	—	Initialized* ¹	Initialized	
TSR_10	Initialized	—	—	—	—	Initialized* ¹	Initialized	
TCNT_10	Initialized	—	—	—	—	Initialized* ¹	Initialized	
TGRA_10	Initialized	—	—	—	—	Initialized* ¹	Initialized	
TGRB_10	Initialized	—	—	—	—	Initialized* ¹	Initialized	
TCR_11	Initialized	—	—	—	—	Initialized* ¹	Initialized	TPU_11
TMDR_11	Initialized	—	—	—	—	Initialized* ¹	Initialized	
TIOR_11	Initialized	—	—	—	—	Initialized* ¹	Initialized	
TIER_11	Initialized	—	—	—	—	Initialized* ¹	Initialized	
TSR_11	Initialized	—	—	—	—	Initialized* ¹	Initialized	
TCNT_11	Initialized	—	—	—	—	Initialized* ¹	Initialized	
TGRA_11	Initialized	—	—	—	—	Initialized* ¹	Initialized	
TGRB_11	Initialized	—	—	—	—	Initialized* ¹	Initialized	
P1DDR	Initialized	—	—	—	—	Initialized* ¹	Initialized	I/O port
P2DDR	Initialized	—	—	—	—	Initialized* ¹	Initialized	
P3DDR	Initialized	—	—	—	—	Initialized* ¹	Initialized	
P6DDR	Initialized	—	—	—	—	Initialized* ¹	Initialized	
PADDR	Initialized	—	—	—	—	Initialized* ¹	Initialized	
PBDDR	Initialized	—	—	—	—	Initialized* ¹	Initialized	
PDDDR	Initialized	—	—	—	—	Initialized* ¹	Initialized	
PEDDR	Initialized	—	—	—	—	Initialized* ¹	Initialized	
PFDDR	Initialized	—	—	—	—	Initialized* ¹	Initialized	
P1ICR	Initialized	—	—	—	—	Initialized* ¹	Initialized	
P2ICR	Initialized	—	—	—	—	Initialized* ¹	Initialized	
P3ICR	Initialized	—	—	—	—	Initialized* ¹	Initialized	
P5ICR	Initialized	—	—	—	—	Initialized* ¹	Initialized	
P6ICR	Initialized	—	—	—	—	Initialized* ¹	Initialized	
PAICR	Initialized	—	—	—	—	Initialized* ¹	Initialized	

Register Abbreviation	Reset	Module Stop State	Sleep Mode	All-Module- Clock-Stop Mode	Software Standby Mode	Deep Software Standby Mode	Hardware Standby Mode	Module
PBICR	Initialized	—	—	—	—	Initialized* ¹	Initialized	I/O port
PDICR	Initialized	—	—	—	—	Initialized* ¹	Initialized	
PEICR	Initialized	—	—	—	—	Initialized* ¹	Initialized	
PFICR	Initialized	—	—	—	—	Initialized* ¹	Initialized	
PORTH	—	—	—	—	—	—	—	
PORTI	—	—	—	—	—	—	—	
PORTJ	—	—	—	—	—	—	—	
PORTK	—	—	—	—	—	—	—	
PHDR	Initialized	—	—	—	—	Initialized* ¹	Initialized	
PIDR	Initialized	—	—	—	—	Initialized* ¹	Initialized	
PJDR	Initialized	—	—	—	—	Initialized* ¹	Initialized	
PKDR	Initialized	—	—	—	—	Initialized* ¹	Initialized	
PHDDR	Initialized	—	—	—	—	Initialized* ¹	Initialized	
PIDDR	Initialized	—	—	—	—	Initialized* ¹	Initialized	
PJDDR	Initialized	—	—	—	—	Initialized* ¹	Initialized	
PKDDR	Initialized	—	—	—	—	Initialized* ¹	Initialized	
PHICR	Initialized	—	—	—	—	Initialized* ¹	Initialized	
PIICR	Initialized	—	—	—	—	Initialized* ¹	Initialized	
PJICR	Initialized	—	—	—	—	Initialized* ¹	Initialized	
PKICR	Initialized	—	—	—	—	Initialized* ¹	Initialized	
PDPCR	Initialized	—	—	—	—	Initialized* ¹	Initialized	
PEPCR	Initialized	—	—	—	—	Initialized* ¹	Initialized	
PFPCR	Initialized	—	—	—	—	Initialized* ¹	Initialized	
PHPCR	Initialized	—	—	—	—	Initialized* ¹	Initialized	
PIPCR	Initialized	—	—	—	—	Initialized* ¹	Initialized	
PJPCR	Initialized	—	—	—	—	Initialized* ¹	Initialized	
PKPCR	Initialized	—	—	—	—	Initialized* ¹	Initialized	
P2ODR	Initialized	—	—	—	—	Initialized* ¹	Initialized	
PFODR	Initialized	—	—	—	—	Initialized* ¹	Initialized	
PFCR0	Initialized	—	—	—	—	Initialized* ¹	Initialized	
PFCR1	Initialized	—	—	—	—	Initialized* ¹	Initialized	

Register Abbreviation	Reset	Module Stop State	Sleep Mode	All-Module- Clock-Stop Mode	Software Standby Mode	Deep Software Standby Mode	Hardware Standby Mode	Module
PFCR2	Initialized	—	—	—	—	Initialized* ¹	Initialized	I/O port
PFCR4	Initialized	—	—	—	—	Initialized* ¹	Initialized	
PFCR6	Initialized	—	—	—	—	Initialized* ¹	Initialized	
PFCR7	Initialized	—	—	—	—	Initialized* ¹	Initialized	
PFCR9	Initialized	—	—	—	—	Initialized* ¹	Initialized	
PFCRA	Initialized	—	—	—	—	Initialized* ¹	Initialized	
PFCRB	Initialized	—	—	—	—	Initialized* ¹	Initialized	
PFCRC	Initialized	—	—	—	—	Initialized* ¹	Initialized	
PFCRD	Initialized	—	—	—	—	Initialized* ¹	Initialized	
SSIER	Initialized	—	—	—	—	Initialized* ¹	Initialized	INTC
DPSBKR0	Initialized	—	—	—	—	—	Initialized	SYSTEM
DPSBKR1	Initialized	—	—	—	—	—	Initialized	
DPSBKR2	Initialized	—	—	—	—	—	Initialized	
DPSBKR3	Initialized	—	—	—	—	—	Initialized	
DPSBKR4	Initialized	—	—	—	—	—	Initialized	
DPSBKR5	Initialized	—	—	—	—	—	Initialized	
DPSBKR6	Initialized	—	—	—	—	—	Initialized	
DPSBKR7	Initialized	—	—	—	—	—	Initialized	
DPSBKR8	Initialized	—	—	—	—	—	Initialized	
DPSBKR9	Initialized	—	—	—	—	—	Initialized	
DPSBKR10	Initialized	—	—	—	—	—	Initialized	
DPSBKR11	Initialized	—	—	—	—	—	Initialized	
DPSBKR12	Initialized	—	—	—	—	—	Initialized	
DPSBKR13	Initialized	—	—	—	—	—	Initialized	
DPSBKR14	Initialized	—	—	—	—	—	Initialized	
DPSBKR15	Initialized	—	—	—	—	—	Initialized	
DSAR_0	Initialized	—	—	—	—	Initialized* ¹	Initialized	DMAC_0
DDAR_0	Initialized	—	—	—	—	Initialized* ¹	Initialized	
DOFR_0	Initialized	—	—	—	—	Initialized* ¹	Initialized	
DTCR_0	Initialized	—	—	—	—	Initialized* ¹	Initialized	
DBSR_0	Initialized	—	—	—	—	Initialized* ¹	Initialized	

Register Abbreviation	Reset	Module Stop State	Sleep Mode	All-Module- Clock-Stop Mode	Software Standby Mode	Deep Software Standby Mode	Hardware Standby Mode	Module
DMDR_0	Initialized	—	—	—	—	Initialized* ¹	Initialized	DMAC_0
DACR_0	Initialized	—	—	—	—	Initialized* ¹	Initialized	
DSAR_1	Initialized	—	—	—	—	Initialized* ¹	Initialized	DMAC_1
DDAR_1	Initialized	—	—	—	—	Initialized* ¹	Initialized	
DOFR_1	Initialized	—	—	—	—	Initialized* ¹	Initialized	
DTCR_1	Initialized	—	—	—	—	Initialized* ¹	Initialized	
DBSR_1	Initialized	—	—	—	—	Initialized* ¹	Initialized	
DMDR_1	Initialized	—	—	—	—	Initialized* ¹	Initialized	
DACR_1	Initialized	—	—	—	—	Initialized* ¹	Initialized	DMAC_2
DSAR_2	Initialized	—	—	—	—	Initialized* ¹	Initialized	
DDAR_2	Initialized	—	—	—	—	Initialized* ¹	Initialized	
DOFR_2	Initialized	—	—	—	—	Initialized* ¹	Initialized	
DTCR_2	Initialized	—	—	—	—	Initialized* ¹	Initialized	
DBSR_2	Initialized	—	—	—	—	Initialized* ¹	Initialized	
DMDR_2	Initialized	—	—	—	—	Initialized* ¹	Initialized	DMAC_3
DACR_2	Initialized	—	—	—	—	Initialized* ¹	Initialized	
DSAR_3	Initialized	—	—	—	—	Initialized* ¹	Initialized	
DDAR_3	Initialized	—	—	—	—	Initialized* ¹	Initialized	
DOFR_3	Initialized	—	—	—	—	Initialized* ¹	Initialized	
DTCR_3	Initialized	—	—	—	—	Initialized* ¹	Initialized	
DBSR_3	Initialized	—	—	—	—	Initialized* ¹	Initialized	DMAC_0
DMDR_3	Initialized	—	—	—	—	Initialized* ¹	Initialized	
DACR_3	Initialized	—	—	—	—	Initialized* ¹	Initialized	
DMRSR_0	Initialized	—	—	—	—	Initialized* ¹	Initialized	
DMRSR_1	Initialized	—	—	—	—	Initialized* ¹	Initialized	DMAC_1
DMRSR_2	Initialized	—	—	—	—	Initialized* ¹	Initialized	DMAC_2
DMRSR_3	Initialized	—	—	—	—	Initialized* ¹	Initialized	DMAC_3
IPRA	Initialized	—	—	—	—	Initialized* ¹	Initialized	INTC
IPRB	Initialized	—	—	—	—	Initialized* ¹	Initialized	
IPRC	Initialized	—	—	—	—	Initialized* ¹	Initialized	
IPRD	Initialized	—	—	—	—	Initialized* ¹	Initialized	

Register Abbreviation	Reset	Module Stop State	Sleep Mode	All-Module- Clock-Stop Mode	Software Standby Mode	Deep Software Standby Mode	Hardware Standby Mode	Module
IPRE	Initialized	—	—	—	—	Initialized* ¹	Initialized	INTC
IPRF	Initialized	—	—	—	—	Initialized* ¹	Initialized	
IPRG	Initialized	—	—	—	—	Initialized* ¹	Initialized	
IPRH	Initialized	—	—	—	—	Initialized* ¹	Initialized	
IPRI	Initialized	—	—	—	—	Initialized* ¹	Initialized	
IPRK	Initialized	—	—	—	—	Initialized* ¹	Initialized	
IPRL	Initialized	—	—	—	—	Initialized* ¹	Initialized	
IPRM	Initialized	—	—	—	—	Initialized* ¹	Initialized	
IPRN	Initialized	—	—	—	—	Initialized* ¹	Initialized	
IPRO	Initialized	—	—	—	—	Initialized* ¹	Initialized	
IPRQ	Initialized	—	—	—	—	Initialized* ¹	Initialized	
IPRR	Initialized	—	—	—	—	Initialized* ¹	Initialized	
ISCRH	Initialized	—	—	—	—	Initialized* ¹	Initialized	
ISCR L	Initialized	—	—	—	—	Initialized* ¹	Initialized	
DTCVBR	Initialized	—	—	—	—	Initialized* ¹	Initialized	BSC
ABWCR	Initialized	—	—	—	—	Initialized* ¹	Initialized	
ASTCR	Initialized	—	—	—	—	Initialized* ¹	Initialized	
WTCRA	Initialized	—	—	—	—	Initialized* ¹	Initialized	
WTCRB	Initialized	—	—	—	—	Initialized* ¹	Initialized	
RDNCR	Initialized	—	—	—	—	Initialized* ¹	Initialized	
CSACR	Initialized	—	—	—	—	Initialized* ¹	Initialized	
IDLCR	Initialized	—	—	—	—	Initialized* ¹	Initialized	
BCR1	Initialized	—	—	—	—	Initialized* ¹	Initialized	
BCR2	Initialized	—	—	—	—	Initialized* ¹	Initialized	
ENDIANCR	Initialized	—	—	—	—	Initialized* ¹	Initialized	
SRAMCR	Initialized	—	—	—	—	Initialized* ¹	Initialized	
BROMCR	Initialized	—	—	—	—	Initialized* ¹	Initialized	
MPXCR	Initialized	—	—	—	—	Initialized* ¹	Initialized	
RAMER	Initialized	—	—	—	—	Initialized* ¹	Initialized	

Register Abbreviation	Reset	Module Stop State	Sleep Mode	All-Module- Clock-Stop Mode	Software Standby Mode	Deep Software Standby Mode	Hardware Standby Mode	Module
MDCR	Initialized	—	—	—	—	Initialized* ¹	Initialized	SYSTEM
SYSCR	Initialized	—	—	—	—	Initialized* ¹	Initialized	
SCKCR	Initialized	—	—	—	—	Initialized* ¹	Initialized	
SBYCR	Initialized	—	—	—	—	Initialized* ¹	Initialized	
MSTPCRA	Initialized	—	—	—	—	Initialized* ¹	Initialized	
MSTPCRB	Initialized	—	—	—	—	Initialized* ¹	Initialized	
MSTPCRC	Initialized	—	—	—	—	Initialized* ¹	Initialized	
FCCS	Initialized	—	—	—	—	Initialized* ¹	Initialized	FLASH
FPCS	Initialized	—	—	—	—	Initialized* ¹	Initialized	
FECS	Initialized	—	—	—	—	Initialized* ¹	Initialized	
FKEY	Initialized	—	—	—	—	Initialized* ¹	Initialized	
FMATS	Initialized	—	—	—	—	Initialized* ¹	Initialized	
FTDAR	Initialized	—	—	—	—	Initialized* ¹	Initialized	
DPSBYCR	Initialized	—	—	—	—	—	Initialized	SYSTEM
DPSWCR	Initialized	—	—	—	—	—	Initialized	
DPSIER	Initialized	—	—	—	—	—	Initialized	
DPSIFR	Initialized	—	—	—	—	—	Initialized	
DPSIEGR	Initialized	—	—	—	—	—	Initialized	
RSTSR	Initialized	—	—	—	—	—	Initialized	
LVDCR* ²	Initialized* ³	—	—	—	—	—	Initialized	
SEMR_2	Initialized	—	—	—	—	Initialized* ¹	Initialized	SCL_2
SMR_3	Initialized	—	—	—	—	Initialized* ¹	Initialized	SCL_3
BRR_3	Initialized	—	—	—	—	Initialized* ¹	Initialized	
SCR_3	Initialized	—	—	—	—	Initialized* ¹	Initialized	
TDR_3	Initialized	Initialized	—	Initialized	Initialized	Initialized* ¹	Initialized	
SSR_3	Initialized	Initialized	—	Initialized	Initialized	Initialized* ¹	Initialized	
RDR_3	Initialized	Initialized	—	Initialized	Initialized	Initialized* ¹	Initialized	
SCMR_3	Initialized	—	—	—	—	Initialized* ¹	Initialized	
SMR_4	Initialized	—	—	—	—	Initialized* ¹	Initialized	SCL_4
BRR_4	Initialized	—	—	—	—	Initialized* ¹	Initialized	
SCR_4	Initialized	—	—	—	—	Initialized* ¹	Initialized	

Register Abbreviation	Reset	Module Stop State	Sleep Mode	All-Module- Clock-Stop Mode	Software Standby Mode	Deep Software Standby Mode	Hardware Standby Mode	Module
TDR_4	Initialized	Initialized	—	Initialized	Initialized	Initialized* ¹	Initialized	SCI_4
SSR_4	Initialized	Initialized	—	Initialized	Initialized	Initialized* ¹	Initialized	
RDR_4	Initialized	Initialized	—	Initialized	Initialized	Initialized* ¹	Initialized	
SCMR_4	Initialized	—	—	—	—	Initialized* ¹	Initialized	
ICCRA_0	Initialized	—	—	—	—	Initialized* ¹	Initialized	IIC2_0
ICCRB_0	Initialized	—	—	—	—	Initialized* ¹	Initialized	
ICMR_0	Initialized	—	—	—	—	Initialized* ¹	Initialized	
ICIER_0	Initialized	—	—	—	—	Initialized* ¹	Initialized	
ICSR_0	Initialized	—	—	—	—	Initialized* ¹	Initialized	
SAR_0	Initialized	—	—	—	—	Initialized* ¹	Initialized	
ICDRT_0	Initialized	—	—	—	—	Initialized* ¹	Initialized	
ICDRR_0	Initialized	—	—	—	—	Initialized* ¹	Initialized	
ICCRA_1	Initialized	—	—	—	—	Initialized* ¹	Initialized	IIC2_1
ICCRB_1	Initialized	—	—	—	—	Initialized* ¹	Initialized	
ICMR_1	Initialized	—	—	—	—	Initialized* ¹	Initialized	
ICIER_1	Initialized	—	—	—	—	Initialized* ¹	Initialized	
ICSR_1	Initialized	—	—	—	—	Initialized* ¹	Initialized	
SAR_1	Initialized	—	—	—	—	Initialized* ¹	Initialized	
ICDRT_1	Initialized	—	—	—	—	Initialized* ¹	Initialized	
ICDRR_1	Initialized	—	—	—	—	Initialized* ¹	Initialized	
TCR_2	Initialized	—	—	—	—	Initialized* ¹	Initialized	TMR_2
TCR_3	Initialized	—	—	—	—	Initialized* ¹	Initialized	TMR_3
TCSR_2	Initialized	—	—	—	—	Initialized* ¹	Initialized	TMR_2
TCSR_3	Initialized	—	—	—	—	Initialized* ¹	Initialized	TMR_3
TCORA_2	Initialized	—	—	—	—	Initialized* ¹	Initialized	TMR_2
TCORA_3	Initialized	—	—	—	—	Initialized* ¹	Initialized	TMR_3
TCORB_2	Initialized	—	—	—	—	Initialized* ¹	Initialized	TMR_2
TCORB_3	Initialized	—	—	—	—	Initialized* ¹	Initialized	TMR_3
TCNT_2	Initialized	—	—	—	—	Initialized* ¹	Initialized	TMR_2
TCNT_3	Initialized	—	—	—	—	Initialized* ¹	Initialized	TMR_3
TCCR_2	Initialized	—	—	—	—	Initialized* ¹	Initialized	TMR_2

Register Abbreviation	Reset	Module Stop State	Sleep Mode	All-Module- Clock-Stop Mode	Software Standby Mode	Deep Software Standby Mode	Hardware Standby Mode	Module
TCCR_3	Initialized	—	—	—	—	Initialized* ¹	Initialized	TMR_3
TCR_4	Initialized	—	—	—	—	Initialized* ¹	Initialized	TPU_4
TMDR_4	Initialized	—	—	—	—	Initialized* ¹	Initialized	
TIOR_4	Initialized	—	—	—	—	Initialized* ¹	Initialized	
TIER_4	Initialized	—	—	—	—	Initialized* ¹	Initialized	
TSR_4	Initialized	—	—	—	—	Initialized* ¹	Initialized	
TCNT_4	Initialized	—	—	—	—	Initialized* ¹	Initialized	
TGRA_4	Initialized	—	—	—	—	Initialized* ¹	Initialized	
TGRB_4	Initialized	—	—	—	—	Initialized* ¹	Initialized	
TCR_5	Initialized	—	—	—	—	Initialized* ¹	Initialized	TPU_5
TMDR_5	Initialized	—	—	—	—	Initialized* ¹	Initialized	
TIOR_5	Initialized	—	—	—	—	Initialized* ¹	Initialized	
TIER_5	Initialized	—	—	—	—	Initialized* ¹	Initialized	
TSR_5	Initialized	—	—	—	—	Initialized* ¹	Initialized	
TCNT_5	Initialized	—	—	—	—	Initialized* ¹	Initialized	
TGRA_5	Initialized	—	—	—	—	Initialized* ¹	Initialized	
TGRB_5	Initialized	—	—	—	—	Initialized* ¹	Initialized	
DTCERA	Initialized	—	—	—	—	Initialized* ¹	Initialized	INTC
DTCERB	Initialized	—	—	—	—	Initialized* ¹	Initialized	
DTCERC	Initialized	—	—	—	—	Initialized* ¹	Initialized	
DTCERD	Initialized	—	—	—	—	Initialized* ¹	Initialized	
DTCERE	Initialized	—	—	—	—	Initialized* ¹	Initialized	
DTCERF	Initialized	—	—	—	—	Initialized* ¹	Initialized	
DTCCR	Initialized	—	—	—	—	Initialized* ¹	Initialized	
INTCR	Initialized	—	—	—	—	Initialized* ¹	Initialized	
CPUPCR	Initialized	—	—	—	—	Initialized* ¹	Initialized	
IER	Initialized	—	—	—	—	Initialized* ¹	Initialized	
ISR	Initialized	—	—	—	—	Initialized* ¹	Initialized	
PORT1	—	—	—	—	—	—	—	I/O port
PORT2	—	—	—	—	—	—	—	
PORT3	—	—	—	—	—	—	—	

Register Abbreviation	Reset	Module Stop State	Sleep Mode	All-Module- Clock-Stop Mode	Software Standby Mode	Deep Software Standby Mode	Hardware Standby Mode	Module
PORT5	—	—	—	—	—	—	—	I/O port
PORT6	—	—	—	—	—	—	—	
PORTA	—	—	—	—	—	—	—	
PORTB	—	—	—	—	—	—	—	
PORTD	—	—	—	—	—	—	—	
PORTE	—	—	—	—	—	—	—	
PORTF	—	—	—	—	—	—	—	
P1DR	Initialized	—	—	—	—	Initialized* ¹	Initialized	
P2DR	Initialized	—	—	—	—	Initialized* ¹	Initialized	
P3DR	Initialized	—	—	—	—	Initialized* ¹	Initialized	
P6DR	Initialized	—	—	—	—	Initialized* ¹	Initialized	
PADR	Initialized	—	—	—	—	Initialized* ¹	Initialized	
PBDR	Initialized	—	—	—	—	Initialized* ¹	Initialized	
PDDR	Initialized	—	—	—	—	Initialized* ¹	Initialized	
PEDR	Initialized	—	—	—	—	Initialized* ¹	Initialized	
PFDR	Initialized	—	—	—	—	Initialized* ¹	Initialized	
SMR_2	Initialized	—	—	—	—	Initialized* ¹	Initialized	SCI_2
BRR_2	Initialized	—	—	—	—	Initialized* ¹	Initialized	
SCR_2	Initialized	—	—	—	—	Initialized* ¹	Initialized	
TDR_2	Initialized	Initialized	—	Initialized	Initialized	Initialized* ¹	Initialized	
SSR_2	Initialized	Initialized	—	Initialized	Initialized	Initialized* ¹	Initialized	
RDR_2	Initialized	Initialized	—	Initialized	Initialized	Initialized* ¹	Initialized	
SCMR_2	Initialized	—	—	—	—	Initialized* ¹	Initialized	
DADR0	Initialized	—	—	—	—	Initialized* ¹	Initialized	D/A
DADR1	Initialized	—	—	—	—	Initialized* ¹	Initialized	
DACR01	Initialized	—	—	—	—	Initialized* ¹	Initialized	
PCR	Initialized	—	—	—	—	Initialized* ¹	Initialized	PPG
PMR	Initialized	—	—	—	—	Initialized* ¹	Initialized	
NDERH	Initialized	—	—	—	—	Initialized* ¹	Initialized	
NDERL	Initialized	—	—	—	—	Initialized* ¹	Initialized	

Register Abbreviation	Reset	Module Stop State	Sleep Mode	All-Module- Clock-Stop Mode	Software Standby Mode	Deep Software Standby Mode	Hardware Standby Mode	Module
PODRH	Initialized	—	—	—	—	Initialized* ¹	Initialized	PPG
PODRL	Initialized	—	—	—	—	Initialized* ¹	Initialized	
NDRH	Initialized	—	—	—	—	Initialized* ¹	Initialized	
NDRL	Initialized	—	—	—	—	Initialized* ¹	Initialized	
SMR_0	Initialized	—	—	—	—	Initialized* ¹	Initialized	SCI_0
BRR_0	Initialized	—	—	—	—	Initialized* ¹	Initialized	
SCR_0	Initialized	—	—	—	—	Initialized* ¹	Initialized	
TDR_0	Initialized	Initialized	—	Initialized	Initialized	Initialized* ¹	Initialized	
SSR_0	Initialized	Initialized	—	Initialized	Initialized	Initialized* ¹	Initialized	SCI_1
RDR_0	Initialized	Initialized	—	Initialized	Initialized	Initialized* ¹	Initialized	
SCMR_0	Initialized	—	—	—	—	Initialized* ¹	Initialized	
SMR_1	Initialized	—	—	—	—	Initialized* ¹	Initialized	
BRR_1	Initialized	—	—	—	—	Initialized* ¹	Initialized	SCI_1
SCR_1	Initialized	—	—	—	—	Initialized* ¹	Initialized	
TDR_1	Initialized	Initialized	—	Initialized	Initialized	Initialized* ¹	Initialized	
SSR_1	Initialized	Initialized	—	Initialized	Initialized	Initialized* ¹	Initialized	
RDR_1	Initialized	Initialized	—	Initialized	Initialized	Initialized* ¹	Initialized	A/D_0
SCMR_1	Initialized	—	—	—	—	Initialized* ¹	Initialized	
ADDRA_0	Initialized	—	—	—	—	Initialized* ¹	Initialized	
ADDRB_0	Initialized	—	—	—	—	Initialized* ¹	Initialized	
ADDRC_0	Initialized	—	—	—	—	Initialized* ¹	Initialized	A/D_0
ADDRD_0	Initialized	—	—	—	—	Initialized* ¹	Initialized	
ADDRE_0	Initialized	—	—	—	—	Initialized* ¹	Initialized	
ADDRF_0	Initialized	—	—	—	—	Initialized* ¹	Initialized	
ADDRG_0	Initialized	—	—	—	—	Initialized* ¹	Initialized	A/D_0
ADDRH_0	Initialized	—	—	—	—	Initialized* ¹	Initialized	
ADCSR_0	Initialized	—	—	—	—	Initialized* ¹	Initialized	
ADCR_0	Initialized	—	—	—	—	Initialized* ¹	Initialized	
TCSR	Initialized	—	—	—	—	Initialized* ¹	Initialized	WDT
TCNT	Initialized	—	—	—	—	Initialized* ¹	Initialized	
RSTCSR	Initialized	—	—	—	—	Initialized* ¹	Initialized	

Register Abbreviation	Reset	Module Stop State	Sleep Mode	All-Module- Clock-Stop Mode	Software Standby Mode	Deep Software Standby Mode	Hardware Standby Mode	Module
TCR_0	Initialized	—	—	—	—	Initialized* ¹	Initialized	TMR_0
TCR_1	Initialized	—	—	—	—	Initialized* ¹	Initialized	TMR_1
TCSR_0	Initialized	—	—	—	—	Initialized* ¹	Initialized	TMR_0
TCSR_1	Initialized	—	—	—	—	Initialized* ¹	Initialized	TMR_1
TCORA_0	Initialized	—	—	—	—	Initialized* ¹	Initialized	TMR_0
TCORA_1	Initialized	—	—	—	—	Initialized* ¹	Initialized	TMR_1
TCORB_0	Initialized	—	—	—	—	Initialized* ¹	Initialized	TMR_0
TCORB_1	Initialized	—	—	—	—	Initialized* ¹	Initialized	TMR_1
TCNT_0	Initialized	—	—	—	—	Initialized* ¹	Initialized	TMR_0
TCNT_1	Initialized	—	—	—	—	Initialized* ¹	Initialized	TMR_1
TCCR_0	Initialized	—	—	—	—	Initialized* ¹	Initialized	TMR_0
TCCR_1	Initialized	—	—	—	—	Initialized* ¹	Initialized	TMR_1
TSTR	Initialized	—	—	—	—	Initialized* ¹	Initialized	TPU
TSYR	Initialized	—	—	—	—	Initialized* ¹	Initialized	
TCR_0	Initialized	—	—	—	—	Initialized* ¹	Initialized	TPU_0
TMDR_0	Initialized	—	—	—	—	Initialized* ¹	Initialized	
TIORH_0	Initialized	—	—	—	—	Initialized* ¹	Initialized	
TIORL_0	Initialized	—	—	—	—	Initialized* ¹	Initialized	
TIER_0	Initialized	—	—	—	—	Initialized* ¹	Initialized	
TSR_0	Initialized	—	—	—	—	Initialized* ¹	Initialized	
TCNT_0	Initialized	—	—	—	—	Initialized* ¹	Initialized	
TGRA_0	Initialized	—	—	—	—	Initialized* ¹	Initialized	
TGRB_0	Initialized	—	—	—	—	Initialized* ¹	Initialized	
TGRC_0	Initialized	—	—	—	—	Initialized* ¹	Initialized	
TGRD_0	Initialized	—	—	—	—	Initialized* ¹	Initialized	
TCR_1	Initialized	—	—	—	—	Initialized* ¹	Initialized	TPU_1
TMDR_1	Initialized	—	—	—	—	Initialized* ¹	Initialized	
TIOR_1	Initialized	—	—	—	—	Initialized* ¹	Initialized	
TIER_1	Initialized	—	—	—	—	Initialized* ¹	Initialized	
TSR_1	Initialized	—	—	—	—	Initialized* ¹	Initialized	
TCNT_1	Initialized	—	—	—	—	Initialized* ¹	Initialized	

Register Abbreviation	Reset	Module Stop State	Sleep Mode	All-Module- Clock-Stop Mode	Software Standby Mode	Deep Software Standby Mode	Hardware Standby Mode	Module
TGRA_1	Initialized	—	—	—	—	Initialized* ¹	Initialized	TPU_1
TGRB_1	Initialized	—	—	—	—	Initialized* ¹	Initialized	
TCR_2	Initialized	—	—	—	—	Initialized* ¹	Initialized	TPU_2
TMDR_2	Initialized	—	—	—	—	Initialized* ¹	Initialized	
TIOR_2	Initialized	—	—	—	—	Initialized* ¹	Initialized	TPU_3
TIER_2	Initialized	—	—	—	—	Initialized* ¹	Initialized	
TSR_2	Initialized	—	—	—	—	Initialized* ¹	Initialized	TPU_3
TCNT_2	Initialized	—	—	—	—	Initialized* ¹	Initialized	
TGRA_2	Initialized	—	—	—	—	Initialized* ¹	Initialized	TPU_3
TGRB_2	Initialized	—	—	—	—	Initialized* ¹	Initialized	
TCR_3	Initialized	—	—	—	—	Initialized* ¹	Initialized	TPU_3
TMDR_3	Initialized	—	—	—	—	Initialized* ¹	Initialized	
TIORH_3	Initialized	—	—	—	—	Initialized* ¹	Initialized	TPU_3
TIORL_3	Initialized	—	—	—	—	Initialized* ¹	Initialized	
TIER_3	Initialized	—	—	—	—	Initialized* ¹	Initialized	TPU_3
TSR_3	Initialized	—	—	—	—	Initialized* ¹	Initialized	
TCNT_3	Initialized	—	—	—	—	Initialized* ¹	Initialized	TPU_3
TGRA_3	Initialized	—	—	—	—	Initialized* ¹	Initialized	
TGRB_3	Initialized	—	—	—	—	Initialized* ¹	Initialized	TPU_3
TGRC_3	Initialized	—	—	—	—	Initialized* ¹	Initialized	
TGRD_3	Initialized	—	—	—	—	Initialized* ¹	Initialized	TPU_3

- Notes: 1. Not initialized in deep software standby mode but initialized by the internal reset when deep software standby mode is released.
2. Supported only by the H8SX/1638L Group.
3. LVDCR is initialized by a pin reset or power-on reset not by a voltage-monitoring reset, deep software standby reset, or watchdog timer reset.

Section 27 Electrical Characteristics

27.1 Absolute Maximum Ratings

Table 27.1 Absolute Maximum Ratings

Item	Symbol	Value	Unit
Power supply voltage	V_{CC} $PLL V_{CC}$	-0.3 to +4.6	V
Input voltage (except for port 5)	V_{in}	-0.3 to $V_{CC} + 0.3$	V
Input voltage (port 5)	V_{in}	-0.3 to $AV_{CC} + 0.3$	V
Reference power supply voltage	V_{ref}	-0.3 to $AV_{CC} + 0.3$	V
Analog power supply voltage	AV_{CC}	-0.3 to +4.6	V
Analog input voltage	V_{AN}	-0.3 to $AV_{CC} + 0.3$	V
Operating temperature	T_{opr}	Regular specifications: -20 to +75* <hr/> Wide-range specifications: -40 to +85*	°C
Storage temperature	T_{stg}	-55 to +125	°C

Caution: Permanent damage to the LSI may result if absolute maximum ratings are exceeded.

Note: * The operating temperature range during programming/erasing of the flash memory is 0°C to +75°C for regular specifications and 0°C to +85°C for wide-range specifications.

27.2 DC Characteristics (H8SX/1638 Group)

Table 27.2 DC Characteristics (1)

Conditions: $V_{CC} = PLLV_{CC} = 3.0\text{ V to }3.6\text{ V}$, $AV_{CC} = 3.0\text{ V to }3.6\text{ V}$, $V_{ref} = 3.0\text{ V to }AV_{CC}$,
 $V_{SS} = PLLV_{SS} = AV_{SS} = 0\text{ V}^{*1}$, $T_a = -20^{\circ}\text{C to }+75^{\circ}\text{C}$ (regular specifications),
 $T_a = -40^{\circ}\text{C to }+85^{\circ}\text{C}$ (wide-range specifications)

Item	Symbol	Min.	Typ.	Max.	Unit	Test Conditions	
Schmitt trigger input voltage	\overline{IRQ} input pin, TPU input pin, TMR input pin, IIC2 input pin, port 2, port 3, port J, port K	VT^-	$V_{CC} \times 0.2$	—	—	V	
		VT^+	—	—	$V_{CC} \times 0.7$	V	
		$VT^+ - VT^-$	$V_{CC} \times 0.06$	—	—	V	
		VT^-	$AV_{CC} \times 0.2$	—	—	V	
	$\overline{IRQ0-B}$ to $\overline{IRQ7-B}$ input pins	VT^-	$AV_{CC} \times 0.2$	—	—	V	
		VT^+	—	—	$AV_{CC} \times 0.7$	V	
		$VT^+ - VT^-$	$AV_{CC} \times 0.06$	—	—	V	
Input high voltage (except Schmitt trigger input pin)	MD, \overline{RES} , \overline{STBY} , EMLE, NMI	V_{IH}	$V_{CC} \times 0.9$	—	$V_{CC} + 0.3$	V	
	EXTAL		$V_{CC} \times 0.7$	—	$V_{CC} + 0.3$		
	Other input pins						
	Port 5		$AV_{CC} \times 0.7$	—	$AV_{CC} + 0.3$		
Input low voltage (except Schmitt trigger input pin)	MD, \overline{RES} , \overline{STBY} , EMLE	V_{IL}	-0.3	—	$V_{CC} \times 0.1$	V	
	EXTAL, NMI		-0.3	—	$V_{CC} \times 0.2$		
	Other input pins		-0.3	—	$V_{CC} \times 0.2$		
Output high voltage	All output pins	V_{OH}	$V_{CC} - 0.5$	—	—	V	$I_{OH} = -200\ \mu\text{A}$
			$V_{CC} - 1.0$	—	—		$I_{OH} = -1\ \text{mA}$
Output low voltage	All output pins	V_{OL}	—	—	0.4	V	$I_{OL} = 1.6\ \text{mA}$
	Port 3		—	—	1.0		$I_{OL} = 10\ \text{mA}$
Input leakage current	\overline{RES}	$ I_{in} $	—	—	10.0	μA	$V_{in} = 0.5\text{ to }V_{CC} - 0.5\text{ V}$
	MD, \overline{STBY} , EMLE, NMI		—	—	1.0		
	Port 5		—	—	1.0		$V_{in} = 0.5\text{ to }AV_{CC} - 0.5\text{ V}$

Table 27.2 DC Characteristics (2)

Conditions: $V_{CC} = PLLV_{CC} = 3.0\text{ V to }3.6\text{ V}$, $AV_{CC} = 3.0\text{ V to }3.6\text{ V}$, $V_{ref} = 3.0\text{ V to }AV_{CC}$,
 $V_{SS} = PLLV_{SS} = AV_{SS} = 0\text{ V}^{*1}$, $T_a = -20^\circ\text{C to }+75^\circ\text{C}$ (regular specifications),
 $T_a = -40^\circ\text{C to }+85^\circ\text{C}$ (wide-range specifications)

Item		Symbol	Min.	Typ.	Max.	Unit	Test Conditions	
Three-state leakage current (off state)	Ports 1, 2, 3, 6, A to K	$ I_{TSI} $	—	—	1.0	μA	$V_{in} = 0.5\text{ to }V_{CC} - 0.5\text{ V}$	
Input pull-up MOS current	Ports D to F, H, I	$-I_p$	10	—	300	μA	$V_{CC} = 3.0\text{ to }3.6\text{ V}$ $V_{in} = 0\text{ V}$	
Input capacitance	All input pins	C_{in}	—	—	15	pF	$V_{in} = 0\text{ V}$ $f = 1\text{ MHz}$ $T_a = 25^\circ\text{C}$	
Current consumption* ²	Normal operation	I_{CC}^{*4}	—	50	80	mA	$f = 50\text{ MHz}$	
	Sleep mode		—	45	52			
	Standby mode	Software standby mode* ³		—	0.15	1.1		$T_a \leq 50^\circ\text{C}$
				—	—	3.5		$50^\circ\text{C} < T_a$
	Deep software standby mode	RAM software retained* ³		—	20	60	μA	$T_a \leq 50^\circ\text{C}$
				—	—	200		$50^\circ\text{C} < T_a$
		RAM power supply halted		—	3	8	μA	$T_a \leq 50^\circ\text{C}$
				—	—	26		$50^\circ\text{C} < T_a$
Hardware standby mode		—	2	7	mA	$T_a \leq 50^\circ\text{C}$		
		—	—	25		$50^\circ\text{C} < T_a$		
	All-module-clock-stop mode* ⁵		—	23	30	mA		
Analog power supply current	During A/D and D/A conversion	AI_{CC}	—	1.0	2.5	mA		
	Standby for A/D and D/A conversion		—	0.5	1.0	μA		

Item		Symbol	Min.	Typ.	Max.	Unit	Test Conditions
Reference power supply current	During A/D and D/A conversion	I_{CC}	—	0.5	1.0	mA	
	Standby for A/D and D/A conversion		—	0.5	1.0	μ A	
RAM standby voltage		V_{RAM}	2.5	—	—	V	
Vcc start voltage* ⁶		$V_{CCSTART}$	—	—	0.8	V	
Vcc rising gradient* ⁶		SV_{CC}	—	—	20	ms/V	

- Notes: 1. When the A/D and D/A converters are not used, the AV_{CC} , V_{ref} , and AV_{SS} pins should not be open. Connect the AV_{CC} and V_{ref} pins to V_{CC} , and the AV_{SS} pin to V_{SS} .
2. Current consumption values are for $V_{IH\ min} = V_{CC} - 0.5\ V$ and $V_{IL\ max} = 0.5\ V$ with all output pins unloaded and all input pull-up MOSs in the off state.
3. The values are for $V_{RAM} \leq V_{CC} < 3.0\ V$, $V_{IH\ min} = V_{CC} \times 0.9$, and $V_{IL\ max} = 0.3\ V$.
4. I_{CC} depends on f as follows:
 $I_{CC\ max} = 25\ (mA) + 1.1\ (mA/MHz) \times f$ (normal operation)
 $I_{CC\ max} = 27\ (mA) + 0.5\ (mA/MHz) \times f$ (sleep mode)
5. The values are for reference.
6. This can be applied when the \overline{RES} pin is held low at power-on.

Table 27.3 Permissible Output Currents

Conditions: $V_{CC} = PLLV_{CC} = 3.0\ V$ to $3.6\ V$, $AV_{CC} = 3.0\ V$ to $3.6\ V$, $V_{ref} = 3.0\ V$ to AV_{CC} ,
 $V_{SS} = PLLV_{SS} = AV_{SS} = 0\ V^*$, $T_a = -20^\circ C$ to $+75^\circ C$ (regular specifications),
 $T_a = -40^\circ C$ to $+85^\circ C$ (wide-range specifications)

Item		Symbol	Min.	Typ.	Max.	Unit
Permissible output low current (per pin)	Output pins except port 3	I_{OL}	—	—	2.0	mA
Permissible output low current (per pin)	Port 3	I_{OL}	—	—	10	mA
Permissible output low current (total)	Total of all output pins	ΣI_{OL}	—	—	80	mA
Permissible output high current (per pin)	All output pins	$-I_{OH}$	—	—	2.0	mA
Permissible output high current (total)	Total of all output pins	$\Sigma -I_{OH}$	—	—	40	mA

Caution: To protect the LSI's reliability, do not exceed the output current values in table 27.3.

Note: * When the A/D and D/A converters are not used, the AV_{CC} , V_{ref} , and AV_{SS} pins should not be open. Connect the AV_{CC} and V_{ref} pins to V_{CC} , and the AV_{SS} pin to V_{SS} .

27.3 DC Characteristics (H8SX/1638L Group)

Table 27.3 DC Characteristics (1)

Conditions: $V_{CC} = PLLV_{CC} = 2.95\text{ V to }3.6\text{ V}$, $AV_{CC} = 3.0\text{ V to }3.6\text{ V}$, $V_{ref} = 3.0\text{ V to }AV_{CC}$,
 $V_{SS} = PLLV_{SS} = AV_{SS} = 0\text{ V}^{*1}$, $T_a = -20^{\circ}\text{C to }+75^{\circ}\text{C}$ (regular specifications),
 $T_a = -40^{\circ}\text{C to }+85^{\circ}\text{C}$ (wide-range specifications)

Applicable products: H8SX/1638L Group

Item	Symbol	Min.	Typ.	Max.	Unit	Test Conditions	
Schmitt trigger input voltage	\overline{IRQ} input pin, TPU input pin, TMR input pin, IIC2 input pin, port 2, port 3, port J, port K	VT^-	$V_{CC} \times 0.2$	—	—	V	
		VT^+	—	—	$V_{CC} \times 0.7$	V	
		$VT^+ - VT^-$	$V_{CC} \times 0.06$	—	—	V	
	$\overline{IRQ0-B}$ to $\overline{IRQ7-B}$ input pins	VT^-	$AV_{CC} \times 0.2$	—	—	V	
	VT^+	—	—	$AV_{CC} \times 0.7$	V		
	$VT^+ - VT^-$	$AV_{CC} \times 0.06$	—	—	V		
Input high voltage (except Schmitt trigger input pin)	MD, RES, STBY, EMLE, NMI	V_{IH}	$V_{CC} \times 0.9$	—	$V_{CC} + 0.3$	V	
	EXTAL		$V_{CC} \times 0.7$	—	$V_{CC} + 0.3$		
	Other input pins						
	Port 5		$AV_{CC} \times 0.7$	—	$AV_{CC} + 0.3$		
Input low voltage (except Schmitt trigger input pin)	MD, RES, STBY, EMLE	V_{IL}	-0.3	—	$V_{CC} \times 0.1$	V	
	EXTAL, NMI		-0.3	—	$V_{CC} \times 0.2$		
	Other input pins		-0.3	—	$V_{CC} \times 0.2$		
Output high voltage	All output pins	V_{OH}	$V_{CC} - 0.5$	—	—	V	$I_{OH} = -200\ \mu\text{A}$
			$V_{CC} - 1.0$	—	—		$I_{OH} = -1\ \text{mA}$
Output low voltage	All output pins	V_{OL}	—	—	0.4	V	$I_{OL} = 1.6\ \text{mA}$
			Port 3	—	—	1.0	$I_{OL} = 10\ \text{mA}$
Input leakage current	\overline{RES}	$ I_{in} $	—	—	10.0	μA	$V_{in} = 0.5\text{ to }V_{CC} - 0.5\text{ V}$
	MD, STBY, EMLE, NMI		—	—	1.0		
	Port 5		—	—	1.0		$V_{in} = 0.5\text{ to }AV_{CC} - 0.5\text{ V}$

Table 27.4 DC Characteristics (2)

Conditions: $V_{CC} = PLLV_{CC} = 2.95\text{ V to }3.6\text{ V}$, $AV_{CC} = 3.0\text{ V to }3.6\text{ V}$, $V_{ref} = 3.0\text{ V to }AV_{CC}$,
 $V_{SS} = PLLV_{SS} = AV_{SS} = 0\text{ V}^{*1}$, $T_a = -20^\circ\text{C to }+75^\circ\text{C}$ (regular specifications),
 $T_a = -40^\circ\text{C to }+85^\circ\text{C}$ (wide-range specifications)

Applicable products: H8SX/1638L Group

Item		Symbol	Min.	Typ.	Max.	Unit	Test Conditions	
Three-state leakage current (off state)	Ports 1, 2, 3, 6, A to K	$ I_{TSL} $	—	—	1.0	μA	$V_{in} = 0.5\text{ to }V_{CC} - 0.5\text{ V}$	
Input pull-up MOS current	Ports D to F, H, I	$-I_p$	10	—	300	μA	$V_{CC} = 2.95\text{ to }3.6\text{ V}$ $V_{in} = 0\text{ V}$	
Input capacitance	All input pins	C_{in}	—	—	15	pF	$V_{in} = 0\text{ V}$ $f = 1\text{ MHz}$ $T_a = 25^\circ\text{C}$	
Current consumption* ²	Normal operation	I_{CC}^{*4}	—	50	80	mA	$f = 50\text{ MHz}$	
	Sleep mode		—	45	52			
	Standby Software standby mode* ³ mode			—	0.15	1.1	mA	$T_a \leq 50^\circ\text{C}$
				—	—	3.5		$50^\circ\text{C} < T_a$
	Deep software standby mode	RAM retained* ³		—	24	67	μA	$T_a \leq 50^\circ\text{C}$
				—	—	200		$50^\circ\text{C} < T_a$
		RAM power supply halted		—	23	35	μA	$T_a \leq 50^\circ\text{C}$
				—	—	60		$50^\circ\text{C} < T_a$
	Hardware standby mode	I_{CC}^{*4}	—	2	7	μA	$T_a \leq 50^\circ\text{C}$	
			—	—	25		$50^\circ\text{C} < T_a$	
	All-module-clock-stop mode* ⁵		—	23	30	mA		
Analog power supply current	During A/D and D/A conversion	AI_{CC}	—	1.0	2.5	mA		
	Standby for A/D and D/A conversion		—	0.5	1.0	μA		
Reference power supply current	During A/D and D/A conversion	AI_{CC}	—	0.5	1.0	mA		
	Standby for A/D and D/A conversion		—	0.5	1.0	μA		

Item	Symbol	Min.	Typ.	Max.	Unit	Test
						Conditions
RAM standby voltage	V_{RAM}	2.5	—	—	V	
Vcc rising gradient* ⁶	SV_{CC}	—	—	20	ms/ V	

- Notes: 1. When the A/D and D/A converters are not used, the AV_{CC} , V_{ref} , and AV_{SS} pins should not be open. Connect the AV_{CC} and V_{ref} pins to V_{CC} , and the AV_{SS} pin to V_{SS} .
2. Current consumption values are for $V_{IH}min = V_{CC} - 0.5$ V and $V_{IL}max = 0.5$ V with all output pins unloaded and all input pull-up MOSs in the off state.
3. The values are for $V_{RAM} \leq V_{CC} < 3.0$ V, $V_{IH}min = V_{CC} \times 0.9$, and $V_{IL}max = 0.3$ V.
4. I_{CC} depends on f as follows:
 $I_{CC}max = 25$ (mA) + 1.1 (mA/MHz) \times f (normal operation)
 $I_{CC}max = 27$ (mA) + 0.5 (mA/MHz) \times f (sleep mode)
5. The values are for reference.
6. This can be applied at power-on.

Table 27.5 Permissible Output Currents

Conditions: $V_{CC} = PLLV_{CC} = 2.95$ V to 3.6 V, $AV_{CC} = 3.0$ V to 3.6 V, $V_{ref} = 3.0$ V to AV_{CC} ,
 $V_{SS} = PLLV_{SS} = AV_{SS} = 0$ V*, $T_a = -20^\circ\text{C}$ to $+75^\circ\text{C}$ (regular specifications),
 $T_a = -40^\circ\text{C}$ to $+85^\circ\text{C}$ (wide-range specifications)

Applicable products: H8SX/1638L Group

Item		Symbol	Min.	Typ.	Max.	Unit
Permissible output low current (per pin)	Output pins except port 3	I_{OL}	—	—	2.0	mA
Permissible output low current (per pin)	Port 3	I_{OL}	—	—	10	mA
Permissible output low current (total)	Total of all output pins	ΣI_{OL}	—	—	80	mA
Permissible output high current (per pin)	All output pins	$-I_{OH}$	—	—	2.0	mA
Permissible output high current (total)	Total of all output pins	$\Sigma -I_{OH}$	—	—	40	mA

Caution: To protect the LSI's reliability, do not exceed the output current values in table 27.5.

Note: * When the A/D and D/A converters are not used, the AV_{CC} , V_{ref} , and AV_{SS} pins should not be open. Connect the AV_{CC} and V_{ref} pins to V_{CC} , and the AV_{SS} pin to V_{SS} .

27.4 AC Characteristics

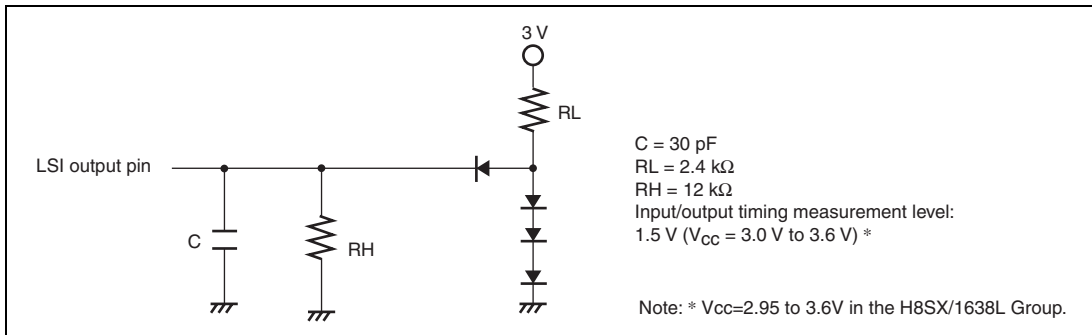

Figure 27.1 Output Load Circuit

27.4.1 Clock Timing

Table 27.6 Clock Timing

Conditions: $V_{CC} = PLLV_{CC} = 3.0 \text{ V to } 3.6 \text{ V}^*$, $AV_{CC} = 3.0 \text{ V to } 3.6 \text{ V}$, $V_{ref} = 3.0 \text{ V to } AV_{CC}$,
 $V_{SS} = PLLV_{SS} = AV_{SS} = 0 \text{ V}$, $I_{\phi} = 8 \text{ MHz to } 50 \text{ MHz}$,
 $B\phi = 8 \text{ MHz to } 50 \text{ MHz}$, $P\phi = 8 \text{ MHz to } 35 \text{ MHz}$,
 $T_a = -20^{\circ}\text{C to } +75^{\circ}\text{C}$ (regular specifications),
 $T_a = -40^{\circ}\text{C to } +85^{\circ}\text{C}$ (wide-range specifications)

Item	Symbol	Min.	Max.	Unit.	Test Conditions
Clock cycle time	t_{cyc}	20	125	ns	Figure 27.2
Clock high pulse width	t_{CH}	5	—	ns	
Clock low pulse width	t_{CL}	5	—	ns	
Clock rising time	t_{Cr}	—	5	ns	
Clock falling time	t_{Cf}	—	5	ns	
Oscillation settling time after reset (crystal)	t_{osc1}	10	—	ms	Figure 27.4
Oscillation settling time after leaving software standby mode (crystal)	t_{osc2}	10	—	ms	Figure 27.3

Note: * $V_{CC}=PLLV_{CC}=2.95 \text{ to } 3.6 \text{ V}$ in the H8SX/1638L Group.

Item	Symbol	Min.	Max.	Unit.	Test Conditions
External clock output delay settling time	t_{DEXT}	1	—	ms	Figure 27.4
External clock input low pulse width	t_{EXL}	27.7	—	ns	Figure 27.5
External clock input high pulse width	t_{EXH}	27.7	—	ns	
External clock rising time	t_{EXr}	—	5	ns	
External clock falling time	t_{EXf}	—	5	ns	

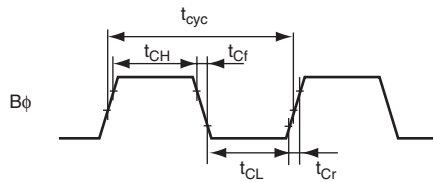

Figure 27.2 External Bus Clock Timing

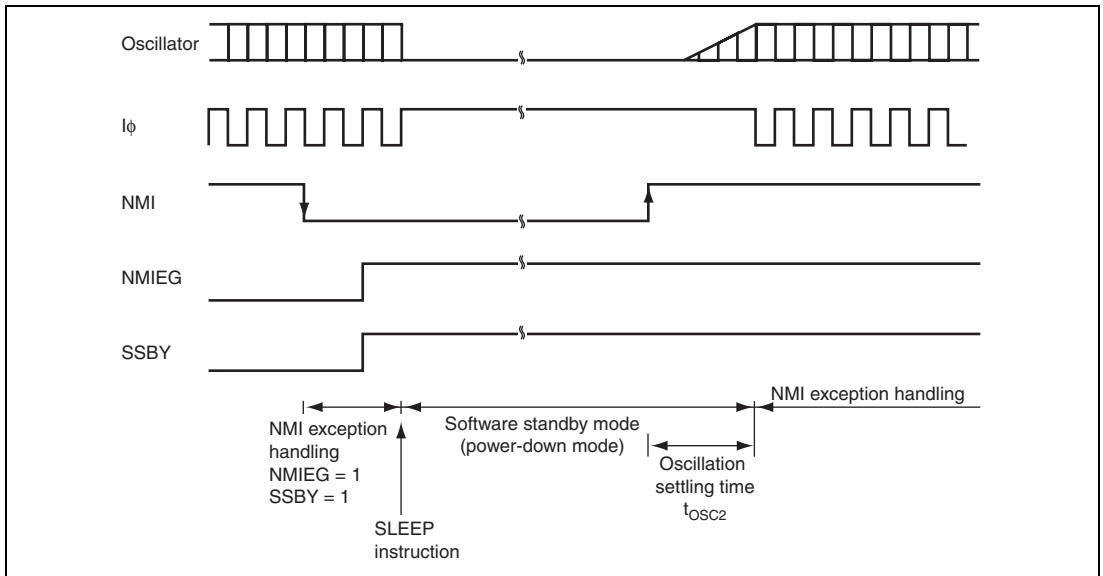

Figure 27.3 Oscillation Settling Timing after Software Standby Mode

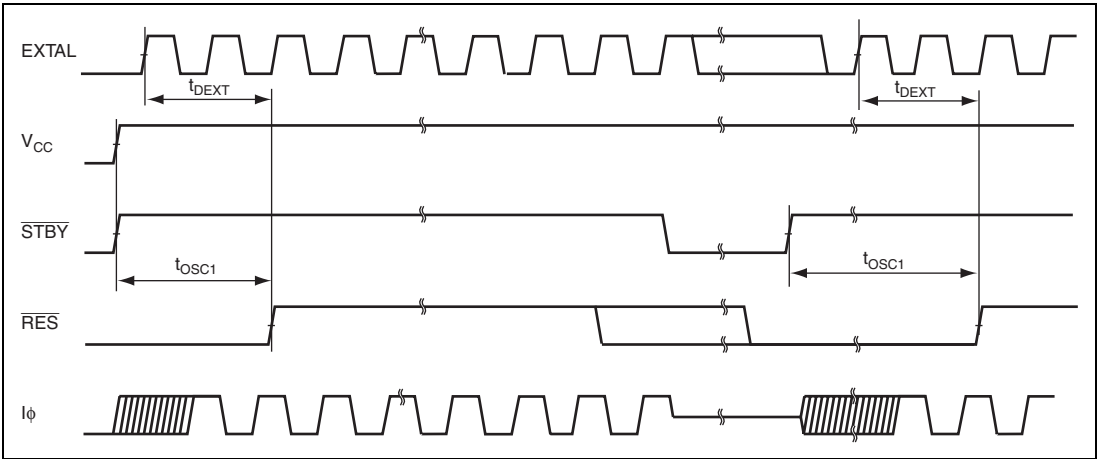

Figure 27.4 Oscillation Settling Timing

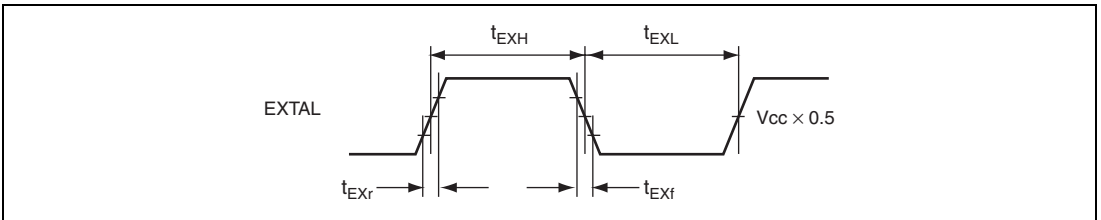

Figure 27.5 External Input Clock Timing

27.4.2 Control Signal Timing

Table 27.7 Control Signal Timing

Conditions: $V_{CC} = PLLV_{CC} = 3.0\text{ V to }3.6\text{ V}^*$, $AV_{CC} = 3.0\text{ V to }3.6\text{ V}$, $V_{ref} = 3.0\text{ V to }AV_{CC}$, $V_{SS} = PLLV_{SS} = AV_{SS} = 0\text{ V}$, $I\phi = 8\text{ MHz to }50\text{ MHz}$,
 $T_a = -20^\circ\text{C to }+75^\circ\text{C}$ (regular specifications),
 $T_a = -40^\circ\text{C to }+85^\circ\text{C}$ (wide-range specifications)

Item	Symbol	Min.	Max.	Unit	Test Conditions
$\overline{\text{RES}}$ setup time	t_{RESS}	200	—	ns	Figure 27.6
$\overline{\text{RES}}$ pulse width	t_{RESW}	20	—	t_{cyc}	
NMI setup time	t_{NMIS}	150	—	ns	Figure 27.7
NMI hold time	t_{NMIH}	10	—	ns	
NMI pulse width (after leaving software standby mode)	t_{NMIW}	200	—	ns	
$\overline{\text{IRQ}}$ setup time	t_{IRQS}	150	—	ns	
$\overline{\text{IRQ}}$ hold time	t_{IROH}	10	—	ns	
$\overline{\text{IRQ}}$ pulse width (after leaving software standby mode)	t_{IRQW}	200	—	ns	

Note: * $V_{CC}=PLLV_{CC}=2.95$ to 3.6 V in the H8SX/1638L Group.

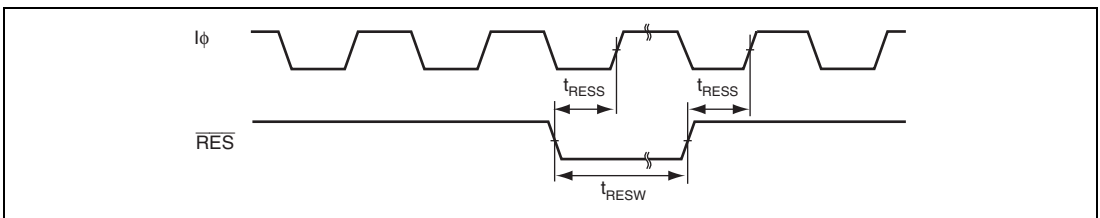
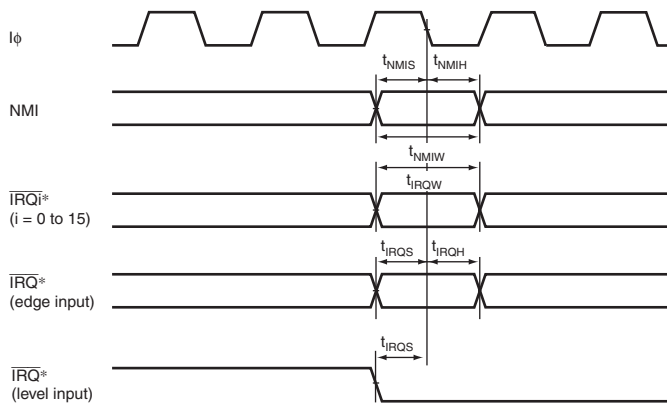

Figure 27.6 Reset Input Timing



Note: * SSIER must be set to cancel software standby mode.

Figure 27.7 Interrupt Input Timing

27.4.3 Bus Timing

Table 27.8 Bus Timing (1)

Conditions: $V_{CC} = PLLV_{CC} = 3.0\text{ V to }3.6\text{ V}^*$, $AV_{CC} = 3.0\text{ V to }3.6\text{ V}$, $V_{ref} = 3.0\text{ V to }AV_{CC}$,
 $V_{SS} = PLLV_{SS} = AV_{SS} = 0\text{ V}$, $B\phi = 8\text{ MHz to }50\text{ MHz}$,
 $T_a = -20^\circ\text{C to }+75^\circ\text{C}$ (regular specifications),
 $T_a = -40^\circ\text{C to }+85^\circ\text{C}$ (wide-range specifications)

Item	Symbol	Min.	Max.	Unit	Test Conditions
Address delay time	t_{AD}	—	15	ns	Figures 27.8 to 27.20
Address setup time 1	t_{AS1}	$0.5 \times t_{cyc} - 8$	—	ns	
Address setup time 2	t_{AS2}	$1.0 \times t_{cyc} - 8$	—	ns	
Address setup time 3	t_{AS3}	$1.5 \times t_{cyc} - 8$	—	ns	
Address setup time 4	t_{AS4}	$2.0 \times t_{cyc} - 8$	—	ns	
Address hold time 1	t_{AH1}	$0.5 \times t_{cyc} - 8$	—	ns	
Address hold time 2	t_{AH2}	$1.0 \times t_{cyc} - 8$	—	ns	
Address hold time 3	t_{AH3}	$1.5 \times t_{cyc} - 8$	—	ns	

Item	Symbol	Min.	Max.	Unit	Test Conditions
$\overline{\text{CS}}$ delay time 1	t_{CSD1}	—	15	ns	Figures 27.8 to 27.20
$\overline{\text{AS}}$ delay time	t_{ASD}	—	15	ns	
$\overline{\text{RD}}$ delay time 1	t_{RSD1}	—	15	ns	
$\overline{\text{RD}}$ delay time 2	t_{RSD2}	—	15	ns	
Read data setup time 1	t_{RDS1}	15	—	ns	
Read data setup time 2	t_{RDS2}	15	—	ns	
Read data hold time 1	t_{RDH1}	0.0	—	ns	
Read data hold time 2	t_{RDH2}	0.0	—	ns	
Read data access time 2	t_{AC2}	—	$1.5 \times t_{\text{cyc}} - 20$	ns	
Read data access time 4	t_{AC4}	—	$2.5 \times t_{\text{cyc}} - 20$	ns	
Read data access time 5	t_{AC5}	—	$1.0 \times t_{\text{cyc}} - 20$	ns	
Read data access time 6	t_{AC6}	—	$2.0 \times t_{\text{cyc}} - 20$	ns	
Read data access time (from address) 1	t_{AA1}	—	$1.0 \times t_{\text{cyc}} - 20$	ns	
Read data access time (from address) 2	t_{AA2}	—	$1.5 \times t_{\text{cyc}} - 20$	ns	
Read data access time (from address) 3	t_{AA3}	—	$2.0 \times t_{\text{cyc}} - 20$	ns	
Read data access time (from address) 4	t_{AA4}	—	$2.5 \times t_{\text{cyc}} - 20$	ns	
Read data access time (from address) 5	t_{AA5}	—	$3.0 \times t_{\text{cyc}} - 20$	ns	

Note: * $V_{\text{CC}} = \text{PLL}V_{\text{CC}} = 2.95$ to 3.6 V in the H8SX/1638L Group.

Table 27.8 Bus Timing (2)

Conditions: $V_{CC} = PLLV_{CC} = 3.0\text{ V to }3.6\text{ V}^*$, $AV_{CC} = 3.0\text{ V to }3.6\text{ V}$, $V_{ref} = 3.0\text{ V to }AV_{CC}$,
 $V_{SS} = PLLV_{SS} = AV_{SS} = 0\text{ V}$, $B\phi = 8\text{ MHz to }50\text{ MHz}$, $T_a = -20^\circ\text{C to }+75^\circ\text{C}$ (regular specifications), $T_a = -40^\circ\text{C to }+85^\circ\text{C}$ (wide-range specifications)

Item	Symbol	Min.	Max.	Unit	Test Conditions
WR delay time 1	t_{WRD1}	—	15	ns	Figures 27.8 to 27.20
WR delay time 2	t_{WRD2}	—	15	ns	
WR pulse width 1	t_{WSW1}	$1.0 \times t_{cyc} - 13$	—	ns	
WR pulse width 2	t_{WSW2}	$1.5 \times t_{cyc} - 13$	—	ns	
Write data delay time	t_{WDD}	—	20	ns	
Write data setup time 1	t_{WDS1}	$0.5 \times t_{cyc} - 13$	—	ns	
Write data setup time 2	t_{WDS2}	$1.0 \times t_{cyc} - 13$	—	ns	
Write data setup time 3	t_{WDS3}	$1.5 \times t_{cyc} - 13$	—	ns	
Write data hold time 1	t_{WDH1}	$0.5 \times t_{cyc} - 8$	—	ns	
Write data hold time 3	t_{WDH3}	$1.5 \times t_{cyc} - 8$	—	ns	
Byte control delay time	t_{UBD}	—	15	ns	Figures 27.13, 27.14
Byte control pulse width 1	t_{UBW1}	—	$1.0 \times t_{cyc} - 15$	ns	Figure 27.13
Byte control pulse width 2	t_{UBW2}	—	$2.0 \times t_{cyc} - 15$	ns	Figure 27.14
Multiplexed address delay time 1	t_{MAD1}	—	15	ns	Figures 27.17, 27.18
Multiplexed address hold time	t_{MAH}	$1.0 \times t_{cyc} - 15$	—	ns	
Multiplexed address setup time 1	t_{MAS1}	$0.5 \times t_{cyc} - 15$	—	ns	
Multiplexed address setup time 2	t_{MAS2}	$1.5 \times t_{cyc} - 15$	—	ns	
Address hold delay time	t_{AHD}	—	15	ns	
Address hold pulse width 1	t_{AHW1}	$1.0 \times t_{cyc} - 15$	—	ns	
Address hold pulse width 2	t_{AHW2}	$2.0 \times t_{cyc} - 15$	—	ns	
WAIT setup time	t_{WTS}	15	—	ns	Figures 27.10, 27.18
WAIT hold time	t_{WTH}	5.0	—	ns	
BREQ setup time	t_{BREQS}	20	—	ns	Figure 27.19
BACK delay time	t_{BACD}	—	15	ns	
Bus floating time	t_{BZD}	—	30	ns	
BREQO delay time	t_{BRQOD}	—	15	ns	Figure 27.20
BS delay time	t_{BSD}	1.0	15	ns	Figures 27.8, 27.9, 27.11 to 27.14
RD/WR delay time	t_{RWD}	—	15	ns	

Note: * $V_{CC}=PLL_{VCC}=2.95$ to 3.6 V in the H8SX/1638L Group.

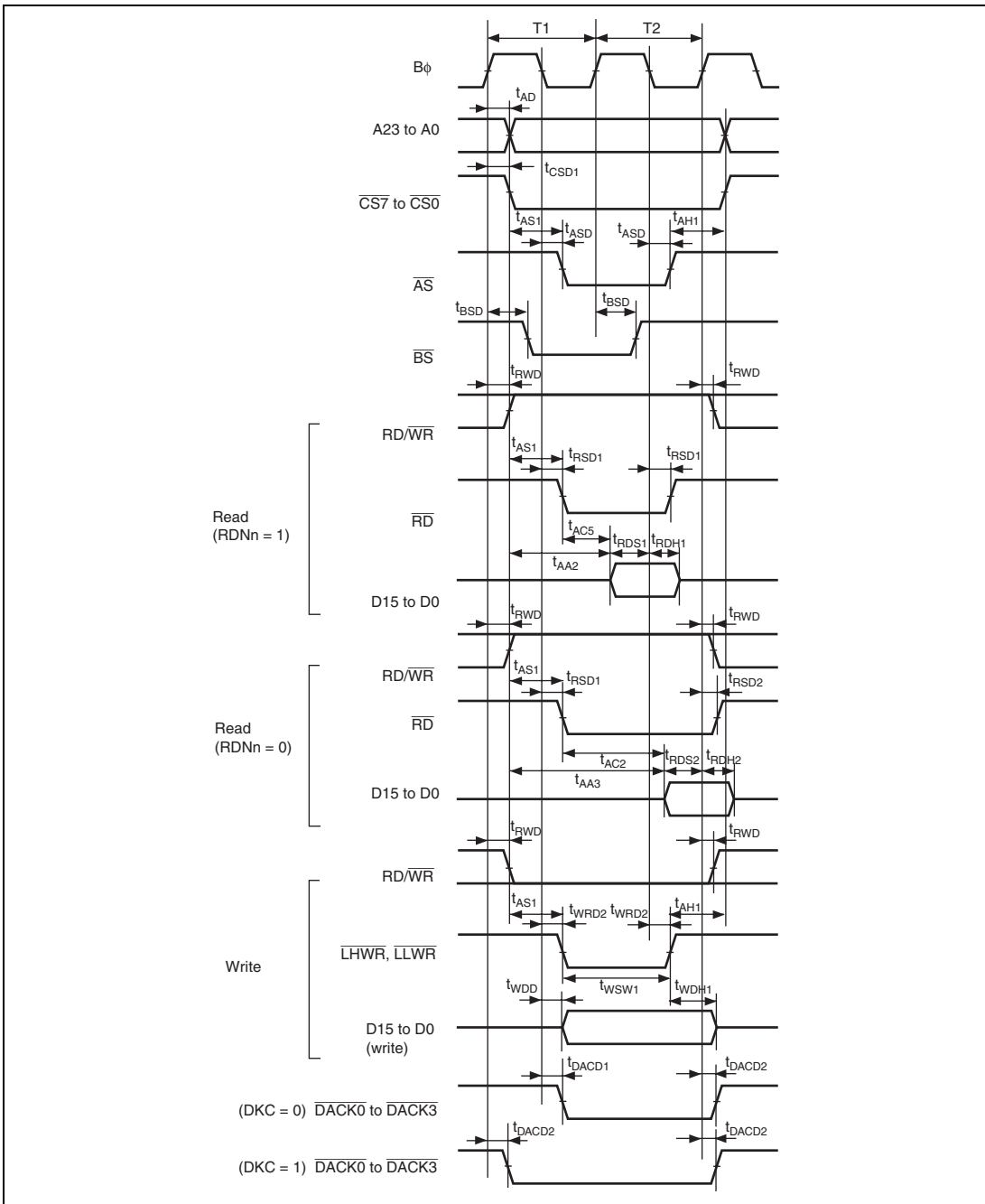

Figure 27.8 Basic Bus Timing: Two-State Access

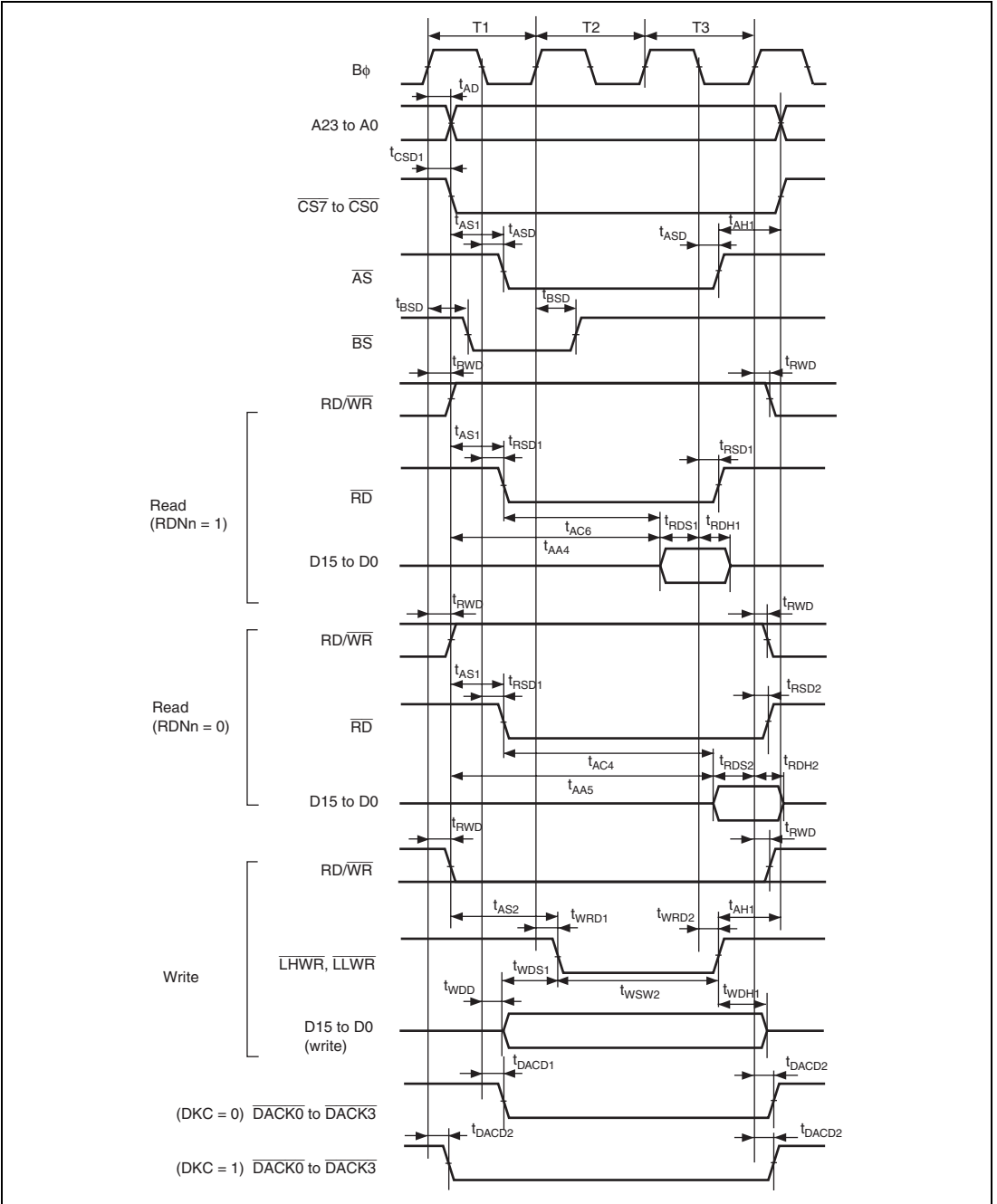

Figure 27.9 Basic Bus Timing: Three-State Access

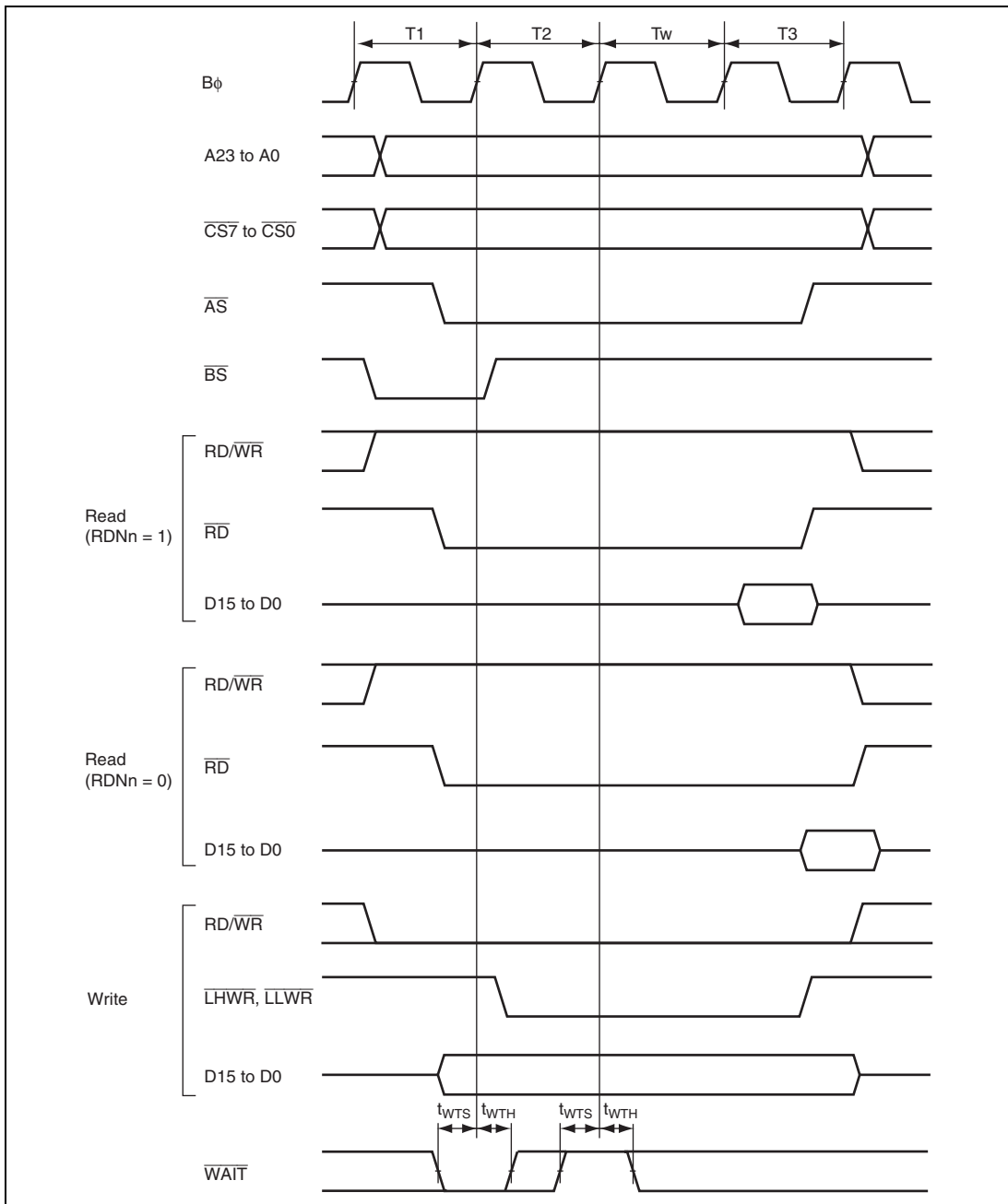

Figure 27.10 Basic Bus Timing: Three-State Access, One Wait

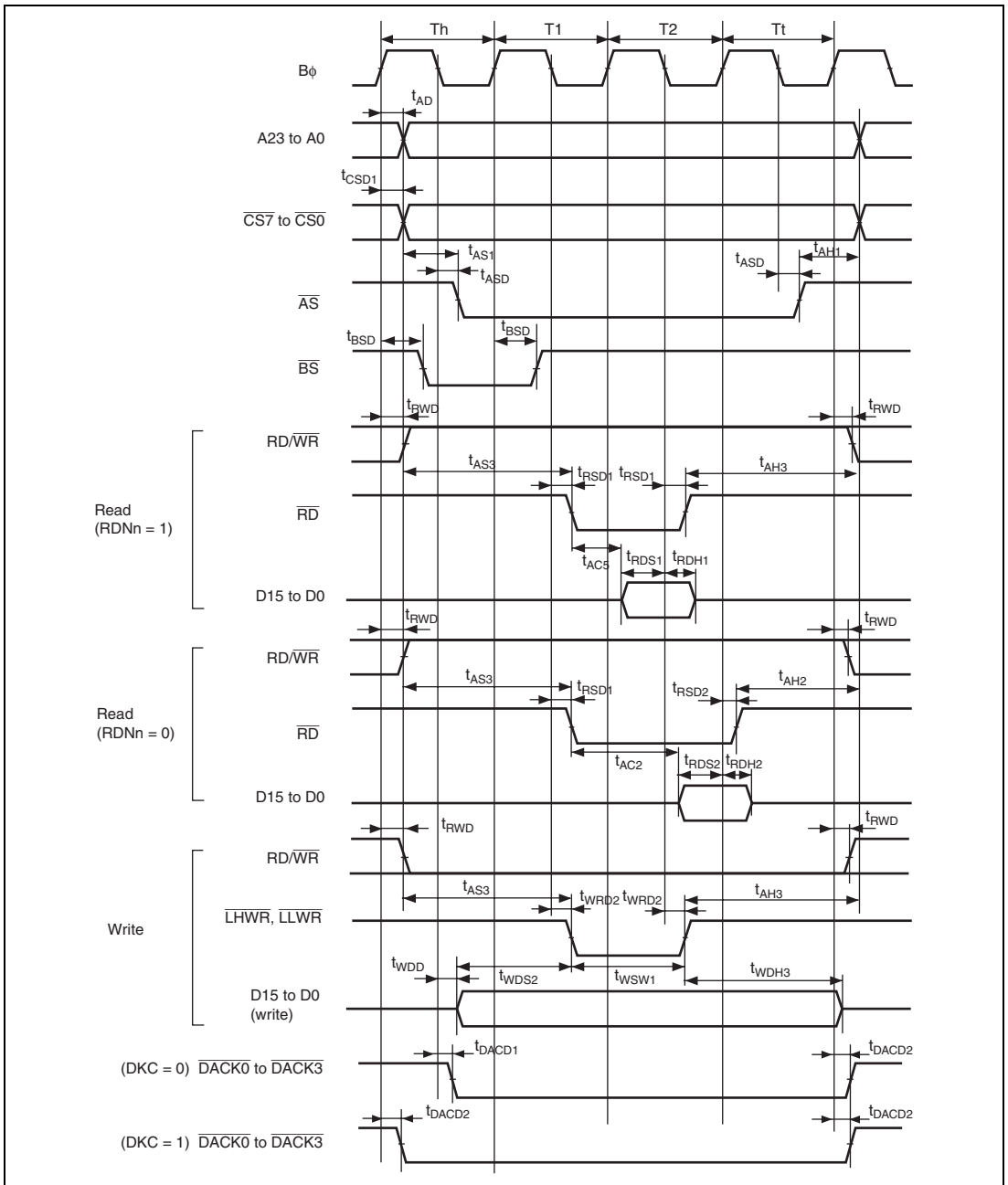

Figure 27.11 Basic Bus Timing: Two-State Access (\overline{CS} Assertion Period Extended)

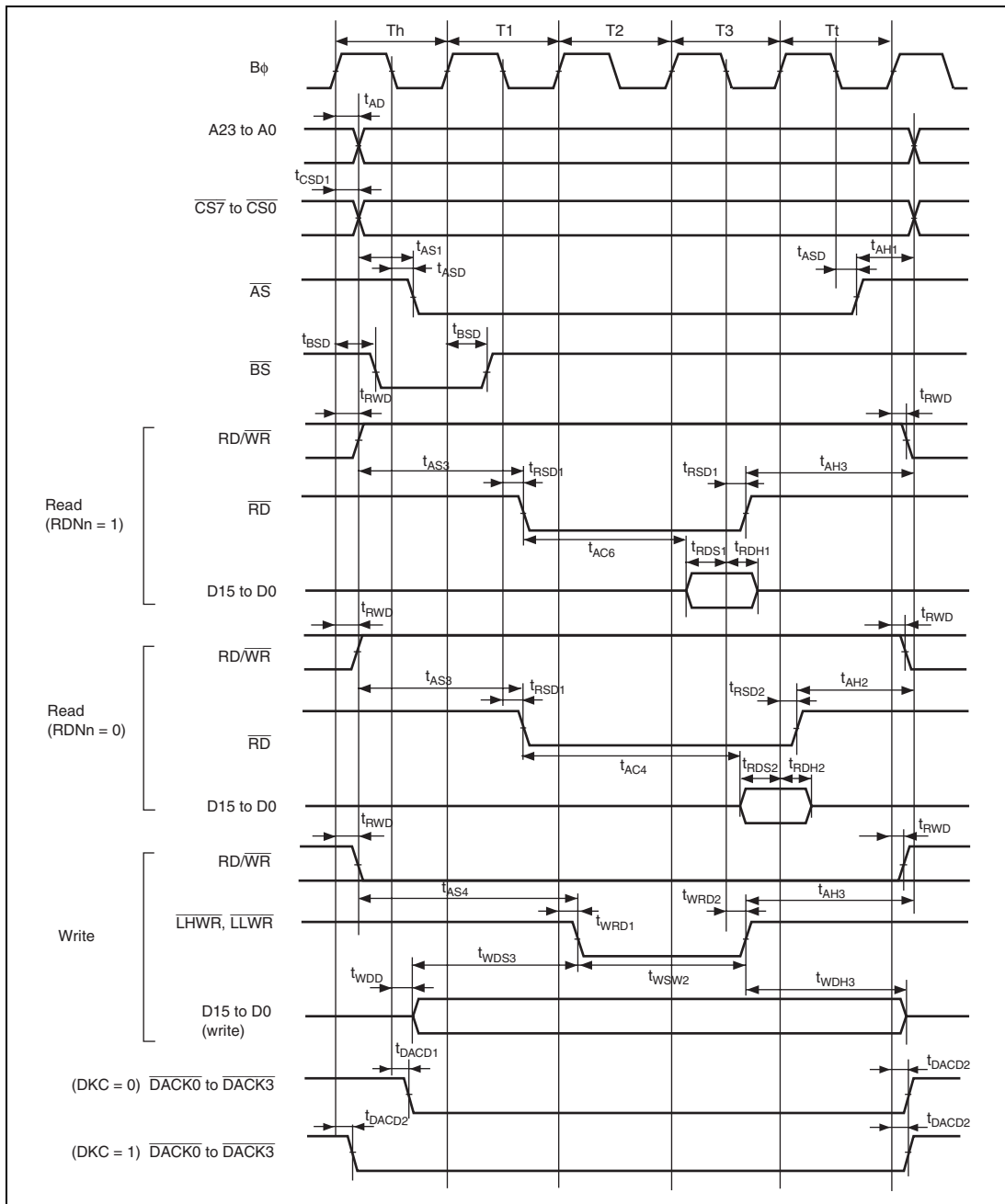

Figure 27.12 Basic Bus Timing: Three-State Access (CS Assertion Period Extended)

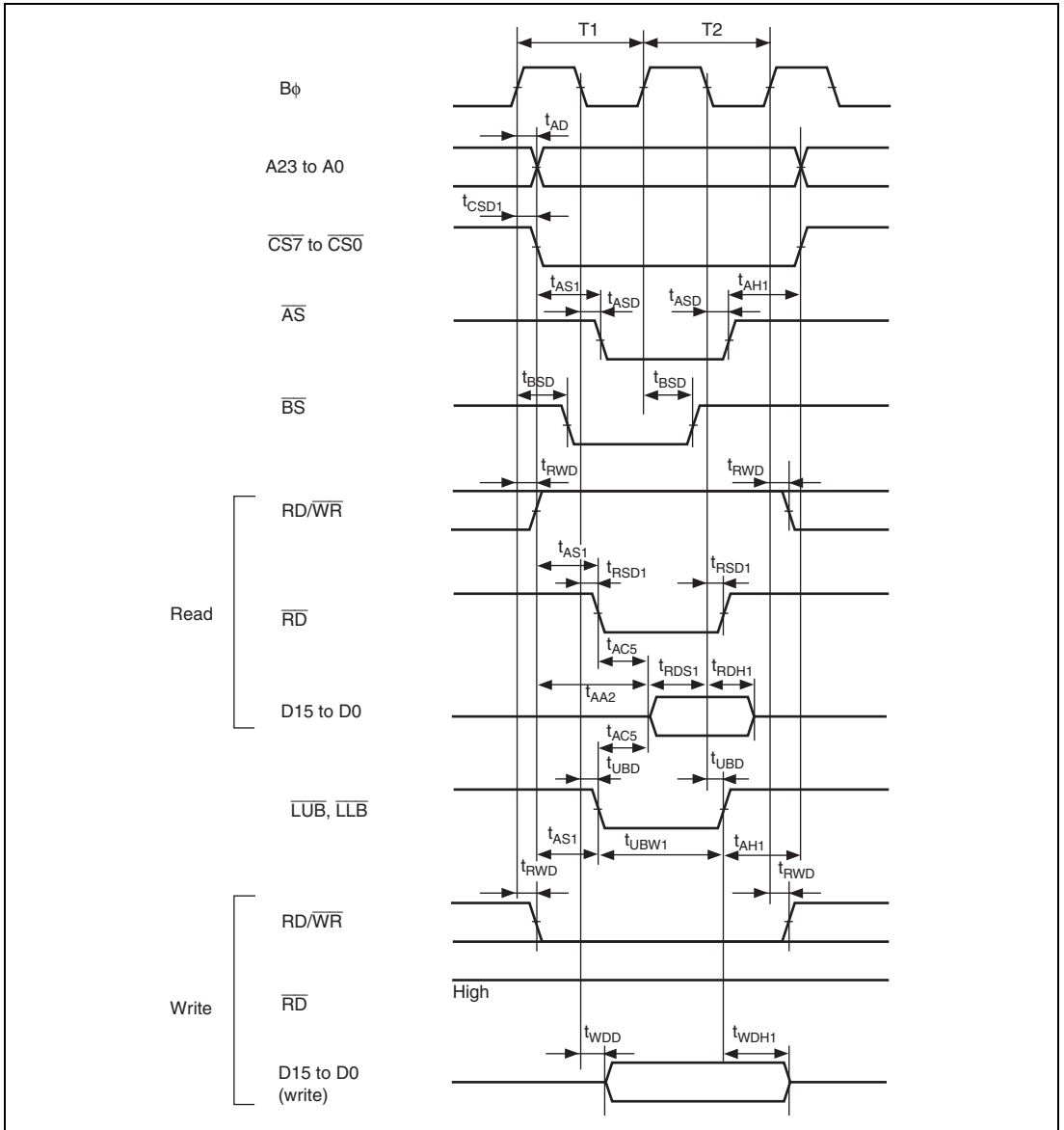

Figure 27.13 Byte Control SRAM: Two-State Read/Write Access

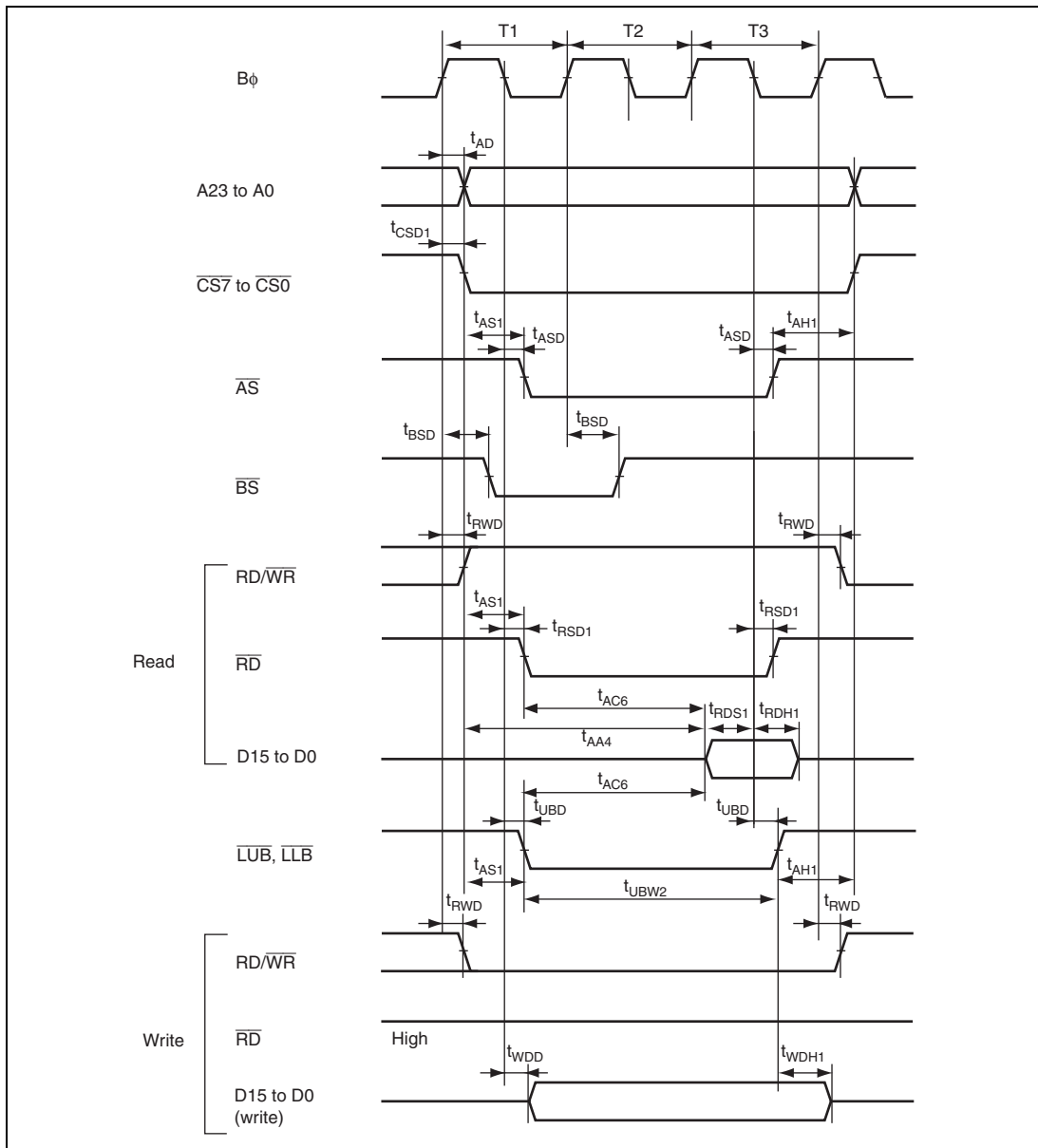

Figure 27.14 Byte Control SRAM: Three-State Read/Write Access

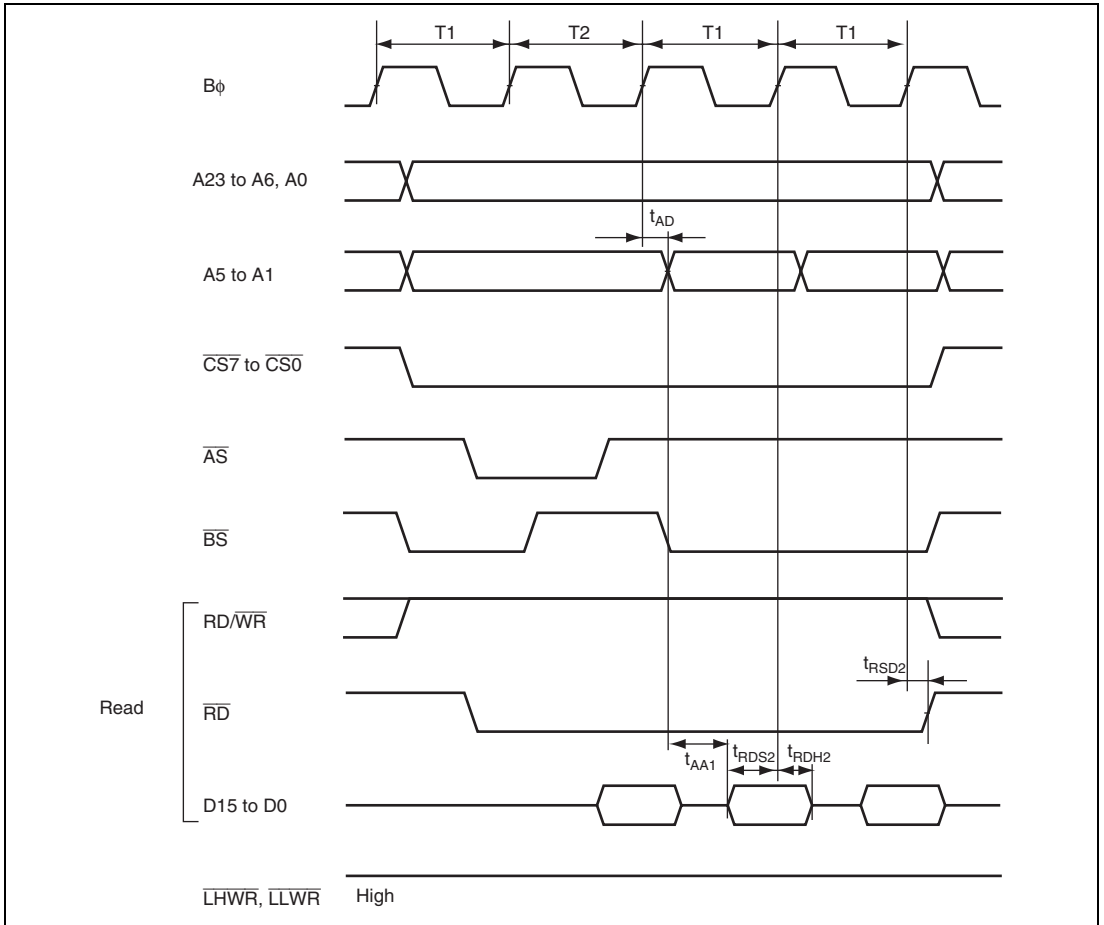

Figure 27.15 Burst ROM Access Timing: One-State Burst Access

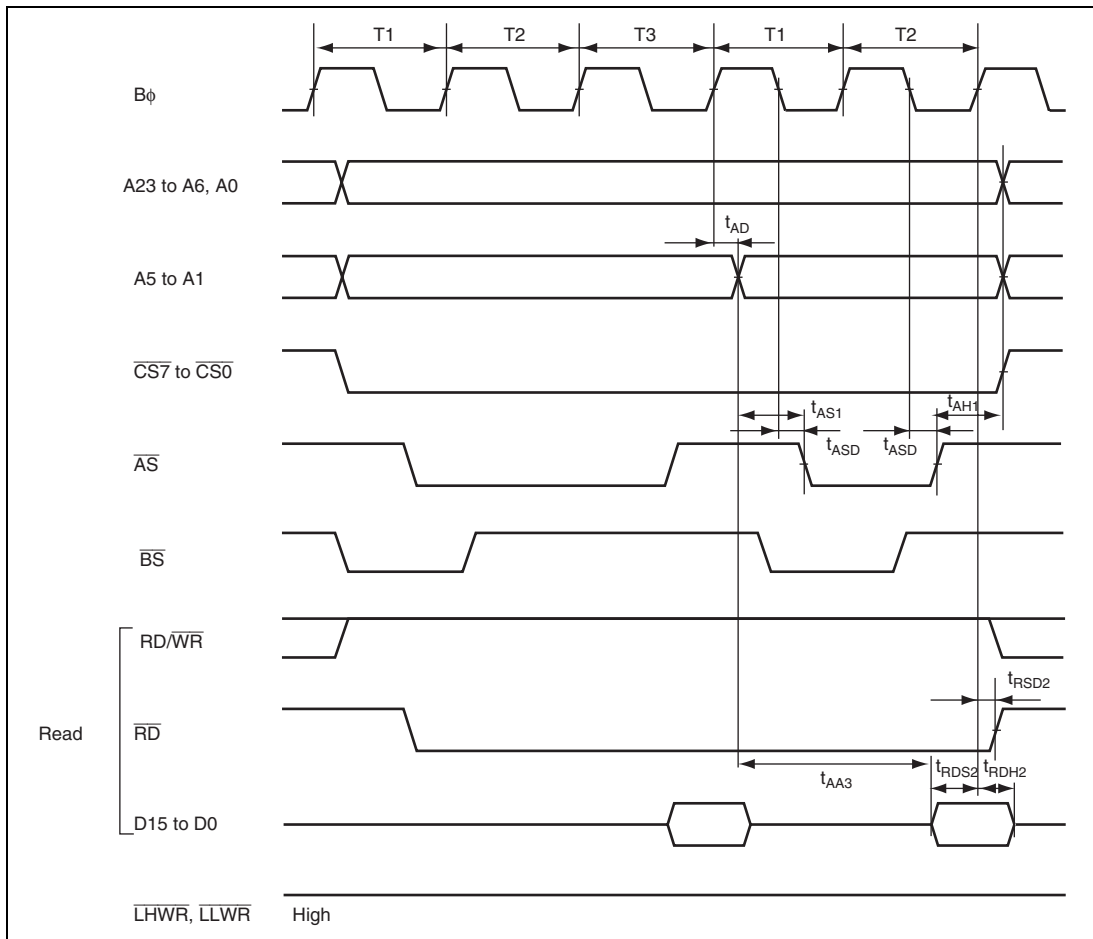
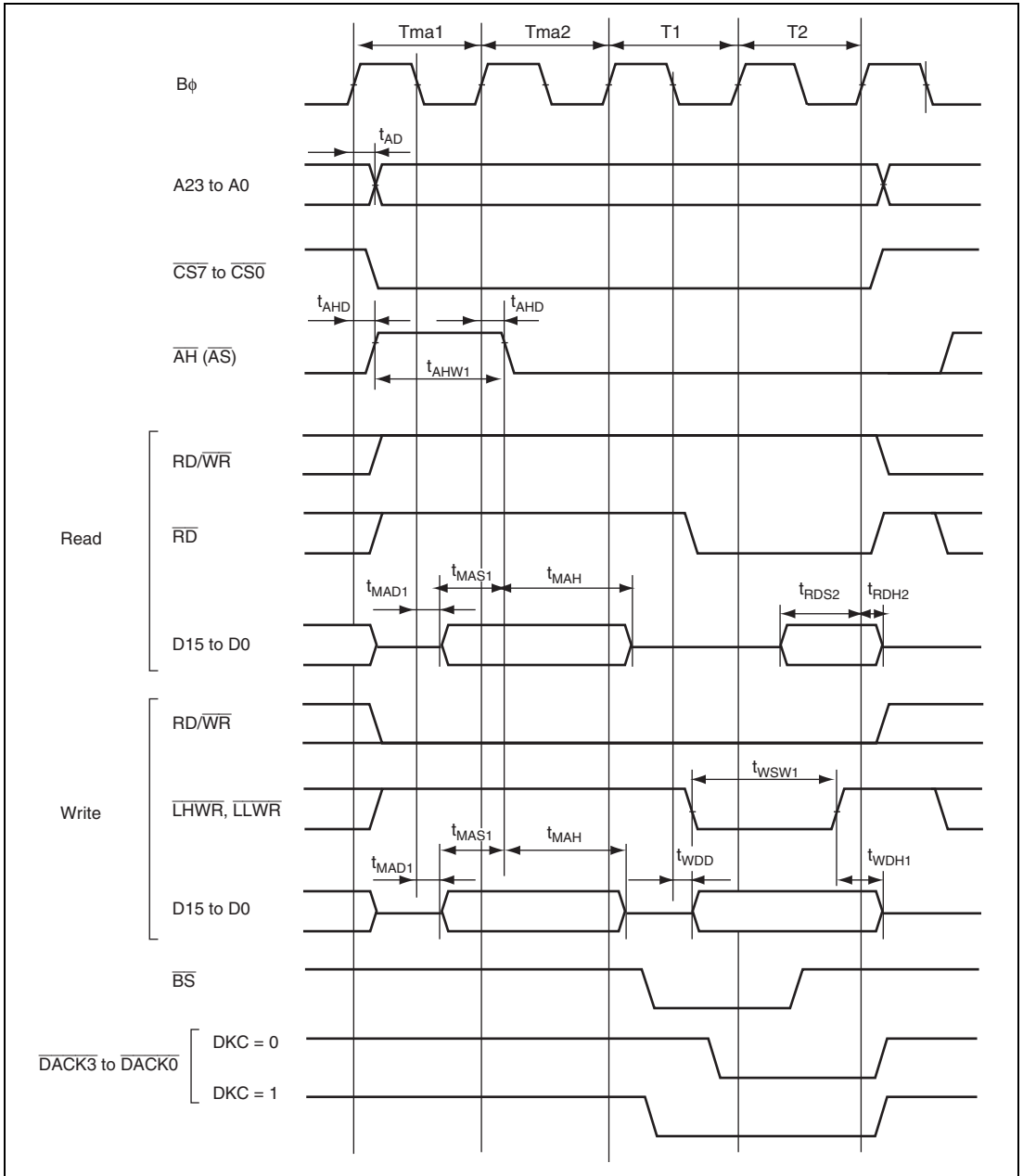

Figure 27.16 Burst ROM Access Timing: Two-State Burst Access



**Figure 27.17 Address/Data Multiplexed Access Timing (No Wait)
(Basic, Four-State Access)**

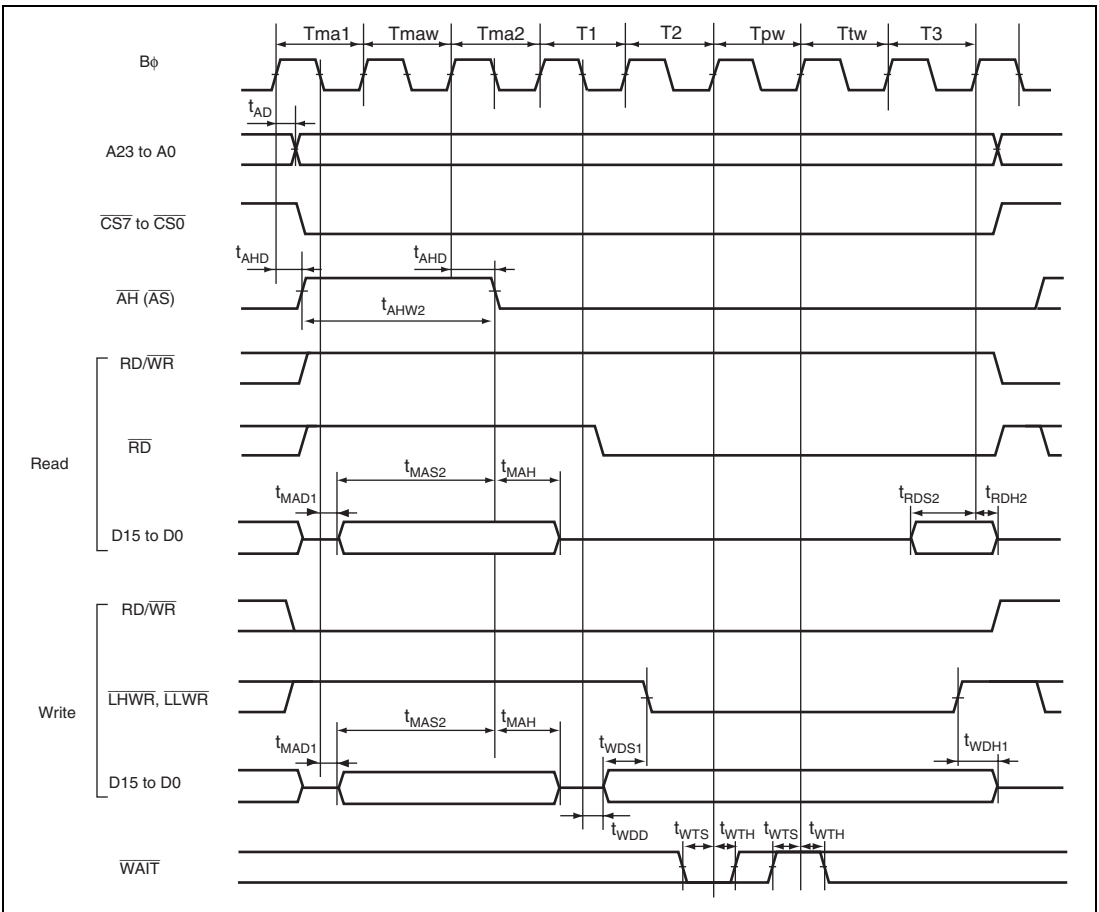

Figure 27.18 Address/Data Multiplexed Access Timing (Wait Control)
 (Address Cycle Program Wait × 1 + Data Cycle Program Wait × 1 +
 Data Cycle Pin Wait × 1)

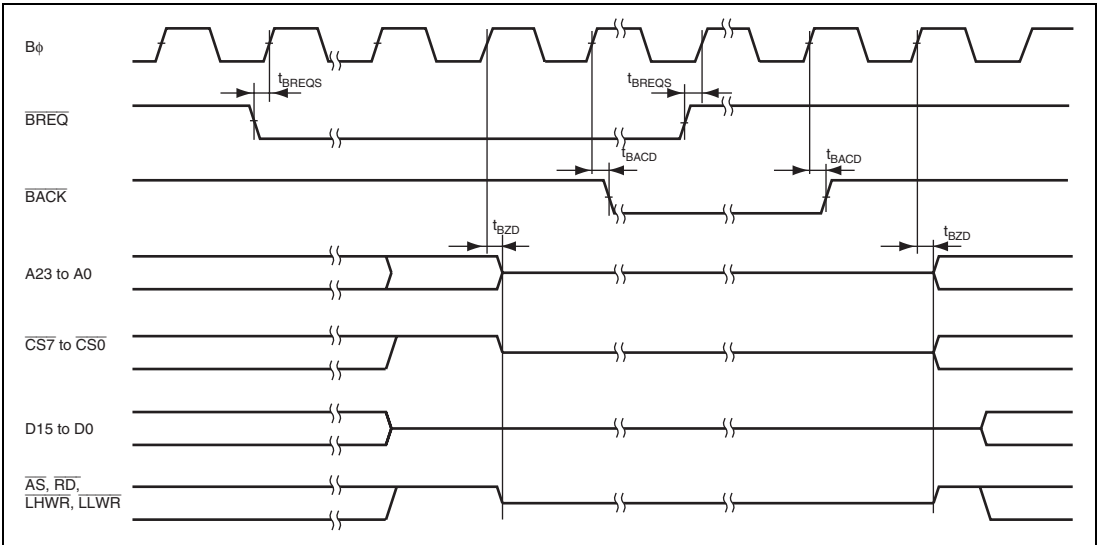

Figure 27.19 External Bus Release Timing

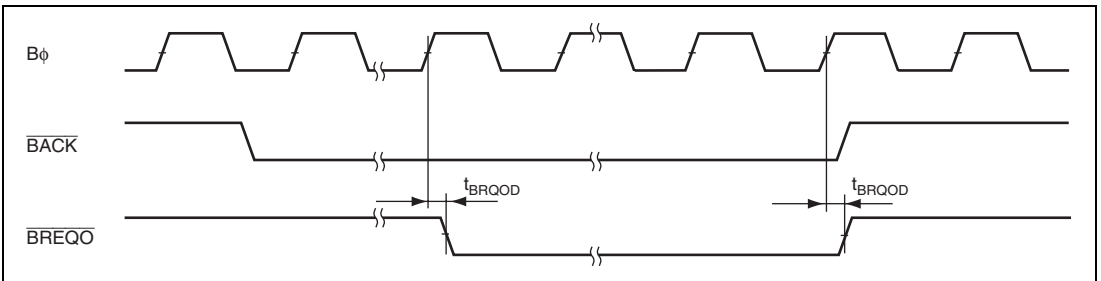

Figure 27.20 External Bus Request Output Timing

27.4.4 DMAC Timing

Table 27.9 DMAC Timing

Conditions: $V_{CC} = PLLV_{CC} = 3.0\text{ V to }3.6\text{ V}^*$, $AV_{CC} = 3.0\text{ V to }3.6\text{ V}$, $V_{ref} = 3.0\text{ V to }AV_{CC}$,
 $V_{SS} = PLLV_{SS} = AV_{SS} = 0\text{ V}$, $B\phi = 8\text{ MHz to }50\text{ MHz}$,
 $T_a = -20^\circ\text{C to }+75^\circ\text{C}$ (regular specifications),
 $T_a = -40^\circ\text{C to }+85^\circ\text{C}$ (wide-range specifications)

Item	Symbol	Min.	Max.	Unit	Test Conditions
$\overline{\text{DREQ}}$ setup time	t_{DRQS}	20	—	ns	Figure 27.21
$\overline{\text{DREQ}}$ hold time	t_{DRQH}	5	—	ns	
$\overline{\text{TEND}}$ delay time	t_{TED}	—	15	ns	Figure 27.22
$\overline{\text{DACK}}$ delay time 1	t_{DACD1}	—	15	ns	Figures 27.23, 27.24
$\overline{\text{DACK}}$ delay time 2	t_{DACD2}	—	15	ns	

Note: * $V_{CC}=PLLV_{CC}=2.95\text{ to }3.6\text{ V}$ in the H8SX/1638L Group.

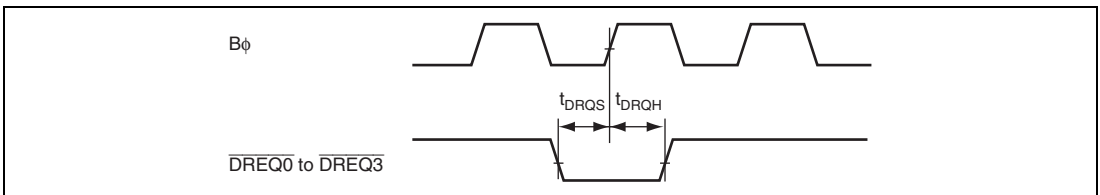

Figure 27.21 DMAC ($\overline{\text{DREQ}}$) Input Timing

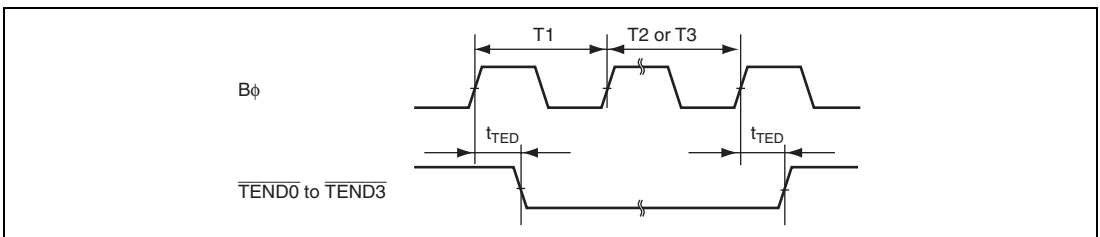

Figure 27.22 DMAC ($\overline{\text{TEND}}$) Output Timing

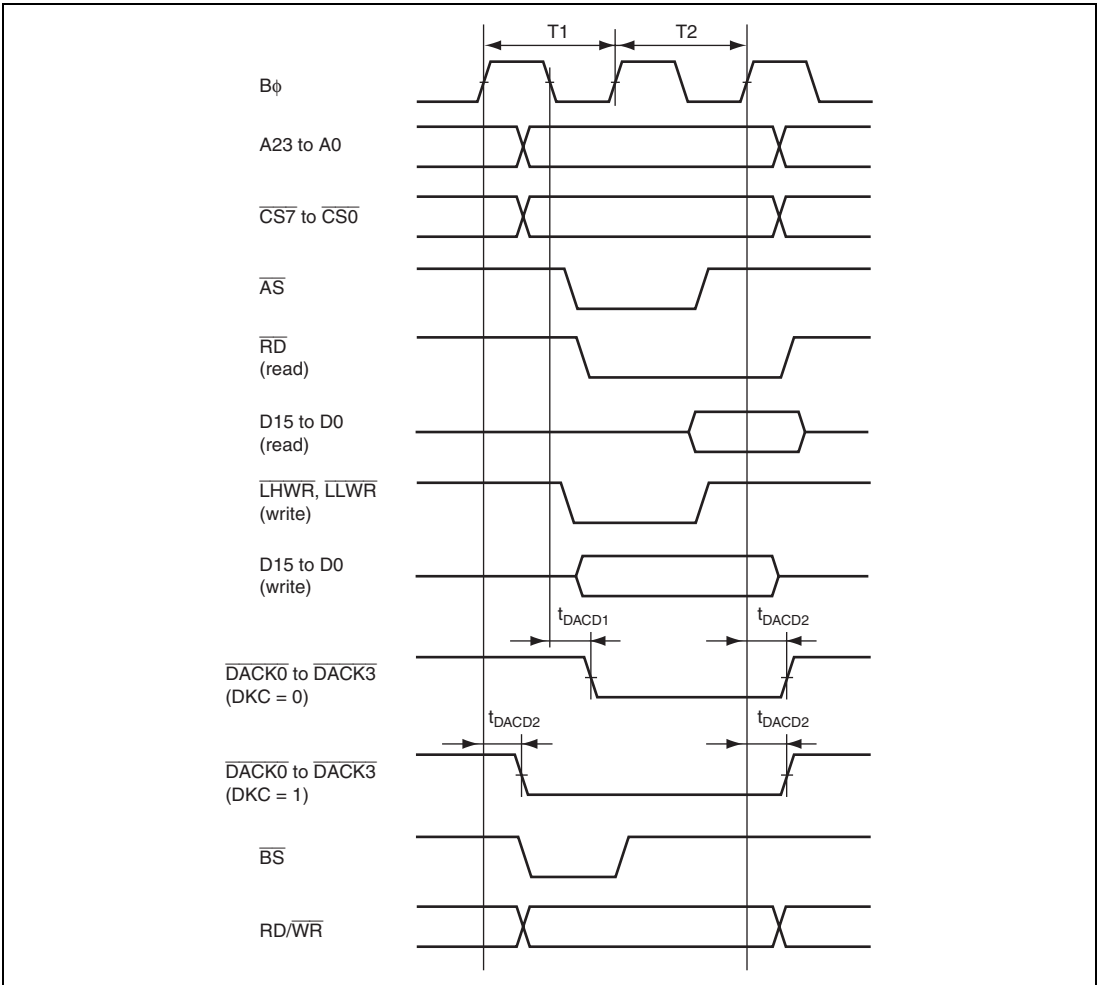

Figure 27.23 DMAC Single-Address Transfer Timing: Two-State Access

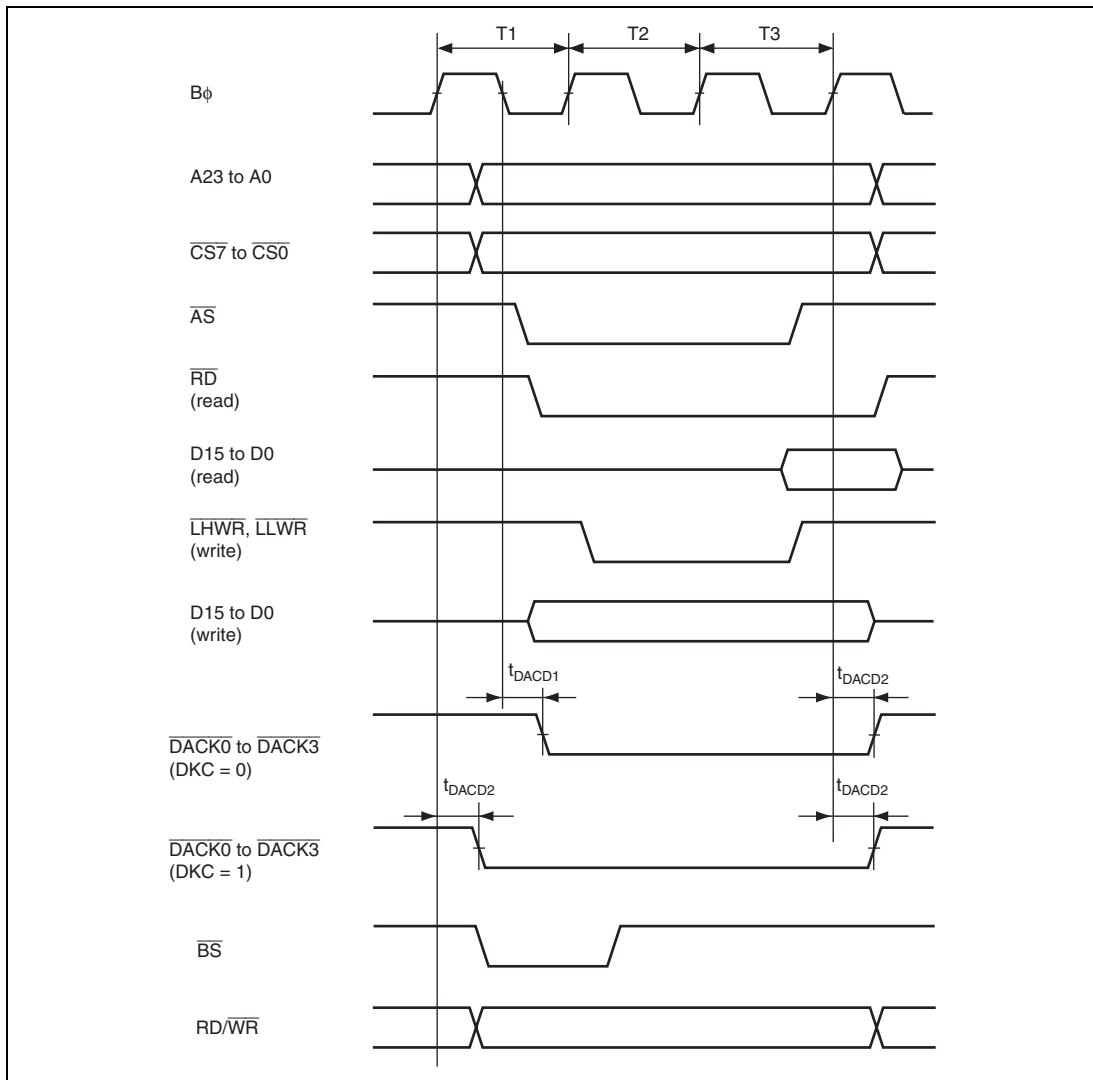

Figure 27.24 DMAC Single-Address Transfer Timing: Three-State Access

27.4.5 Timing of On-Chip Peripheral Modules

Table 27.10 Timing of On-Chip Peripheral Modules

Conditions: $V_{CC} = PLLV_{CC} = 3.0\text{ V to }3.6\text{ V}^{*1}$, $AV_{CC} = 3.0\text{ V to }3.6\text{ V}$, $V_{ref} = 3.0\text{ V to }AV_{CC}$,
 $V_{SS} = PLLV_{SS} = AV_{SS} = 0\text{ V}$, $P\phi = 8\text{ MHz to }35\text{ MHz}$,
 $T_a = -20^{\circ}\text{C to }+75^{\circ}\text{C}$ (regular specifications),
 $T_a = -40^{\circ}\text{C to }+85^{\circ}\text{C}$ (wide-range specifications)

	Item	Symbol	Min.	Max.	Unit	Test Conditions	
I/O ports	Output data delay time	t_{PWD}	—	40	ns	Figure 27.25	
	Input data setup time	t_{PRS}	25	—	ns		
	Input data hold time	t_{PRH}	25	—	ns		
TPU	Timer output delay time	t_{TOCD}	—	40	ns	Figure 27.26	
	Timer input setup time	t_{TICS}	25	—	ns		
	Timer clock input setup time	t_{TCKS}	25	—	ns	Figure 27.27	
	Timer clock pulse width	Single-edge setting	t_{TCKWH}	1.5	—	t_{cyc}	
		Both-edge setting	t_{TCKWL}	2.5	—	t_{cyc}	
PPG	Pulse output delay time	t_{POD}	—	40	ns	Figure 27.28	
8-bit timer	Timer output delay time	t_{TMOD}	—	40	ns	Figure 27.29	
	Timer reset input setup time	t_{TMRS}	25	—	ns	Figure 27.30	
	Timer clock input setup time	t_{TMCS}	25	—	ns	Figure 27.31	
	Timer clock pulse width	Single-edge setting	t_{TMCWH}	1.5	—	t_{cyc}	
		Both-edge setting	t_{TMCWL}	2.5	—	t_{cyc}	
WDT	Overflow output delay time	t_{WOVD}	—	40	ns	Figure 27.32	
SCI	Input clock cycle	Asynchronous	t_{Scyc}	4	—	t_{cyc}	Figure 27.33
		Clocked synchronous		6	—		
	Input clock pulse width	t_{SCKW}	0.4	0.6	t_{Scyc}		
	Input clock rise time	t_{SCKr}	—	1.5	t_{cyc}		
	Input clock fall time	t_{SCKf}	—	1.5	t_{cyc}		

	Item	Symbol	Min.	Max.	Unit	Test Conditions
SCI	Transmit data delay time	t_{TXD}	—	40	ns	Figure 27.34
	Receive data setup time (clocked synchronous)	t_{RXS}	40	—	ns	
	Receive data hold time (clocked synchronous)	t_{RXH}	40	—	ns	
A/D converter	Trigger input setup time	t_{TRGS}	30	—	ns	Figure 27.35
IIC2	SCL input cycle time	t_{SCL}	$12 t_{cyc} + 600$	—	ns	Figure 27.36
	SCL input high pulse width	t_{SCLH}	$3 t_{cyc} + 300$	—	ns	
	SCL input low pulse width	t_{SCLL}	$5 t_{cyc} + 300$	—	ns	
	SCL, SDA input falling time	t_{Sf}	—	300	ns	
	SCL, SDA input spike pulse removal time	t_{SP}	—	$1 t_{cyc}$	ns	
	SDA input bus free time	t_{BUF}	$5 t_{cyc}$	—	ns	
	Start condition input hold time	t_{STAH}	$3 t_{cyc}$	—	ns	
	Retransmit start condition input setup time	t_{STAS}	$3 t_{cyc}$	—	ns	
	Stop condition input setup time	t_{STOS}	$1 t_{cyc} + 20$	—	ns	
	Data input setup time	t_{SDAS}	0	—	ns	
	Data input hold time	t_{SDAH}	0	—	ns	
	SCL, SDA capacitive load	Cb	—	400	pF	
	SCL, SDA falling time	t_{Sf}	—	300	ns	

Item	Symbol	Min.	Max.	Unit	Test Conditions
Boundary scan TCK clock cycle time	t_{TCKcyc}	50* ²	—	ns	Figure 27.37
TCK clock high level pulse width	t_{TCKH}	20	—	ns	
TCK clock low level pulse width	t_{TCKL}	20	—	ns	
TCK clock rising time	t_{TCKr}	—	5	ns	
TCK clock falling time	t_{TCKf}	—	5	ns	
\overline{TRST} pulse width	t_{TRSTW}	20	—	Tcyc	Figure 27.38
TMS setup time	t_{TMSS}	20	—	ns	Figure 27.39
TMS hold time	t_{TMSh}	20	—	ns	
TDI setup time	t_{TDIS}	20	—	ns	
TDI hold time	t_{TDIH}	20	—	ns	
TDO data delay time	t_{TDOD}	—	23	ns	

Notes: 1. $V_{cc}=PLL_{Vcc}=2.95$ to $3.6V$ in the H8SX/1638L Group.

2. $t_{TCKcyc} \geq t_{TCKcyc}$

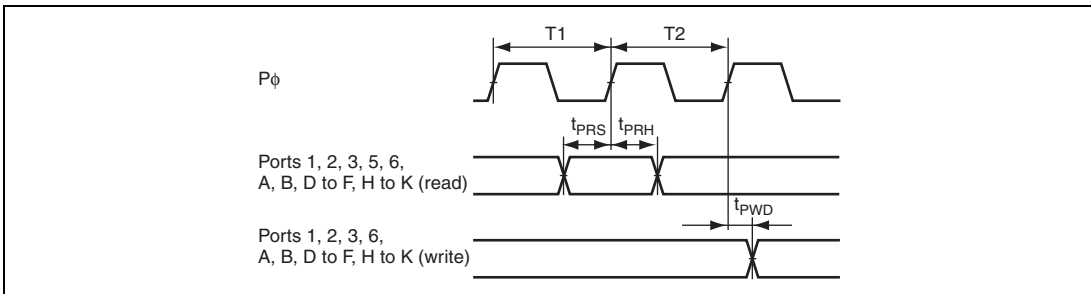

Figure 27.25 I/O Port Input/Output Timing

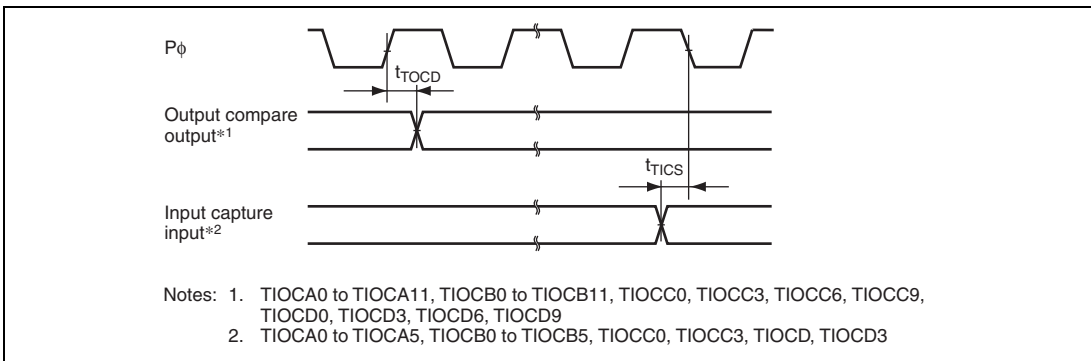

Figure 27.26 TPU Input/Output Timing

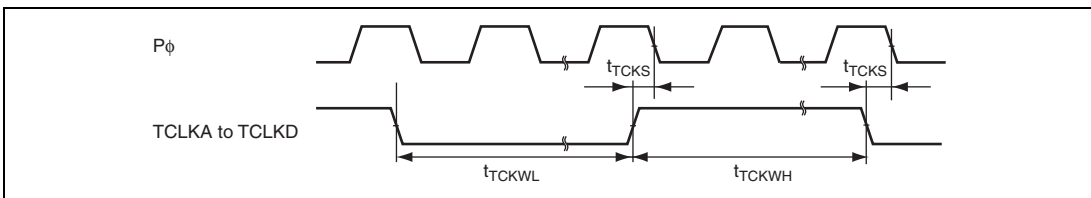

Figure 27.27 TPU Clock Input Timing

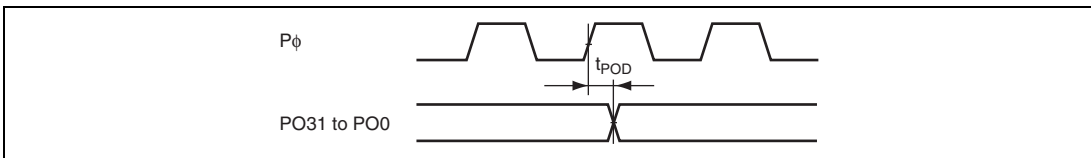

Figure 27.28 PPG Output Timing

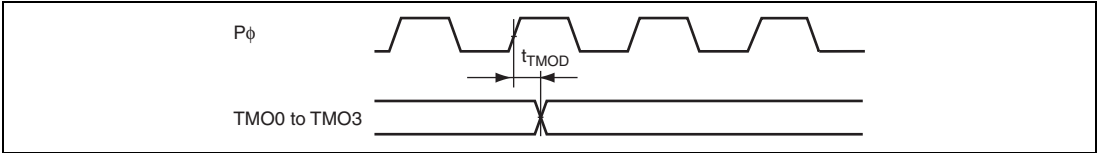

Figure 27.29 8-Bit Timer Output Timing

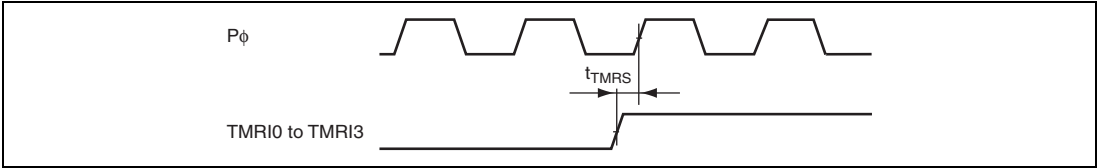

Figure 27.30 8-Bit Timer Reset Input Timing

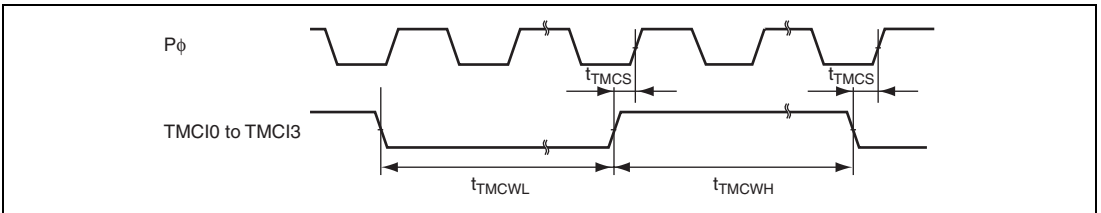

Figure 27.31 8-Bit Timer Clock Input Timing

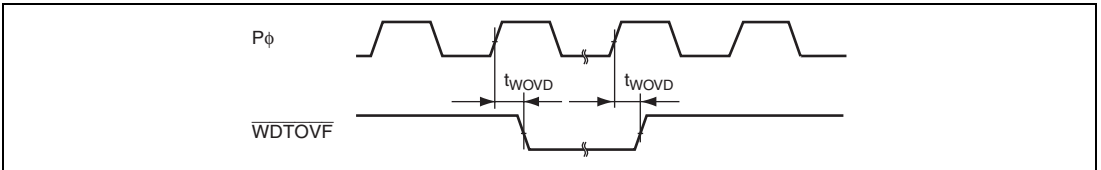

Figure 27.32 WDT Output Timing

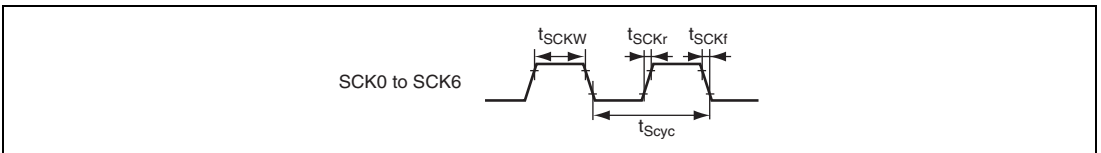

Figure 27.33 SCK Clock Input Timing

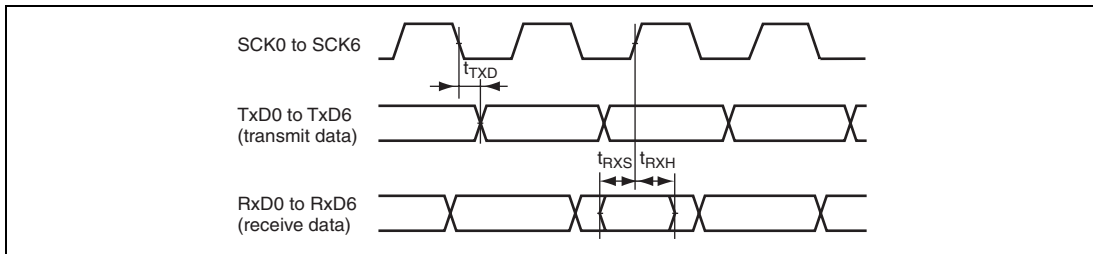

Figure 27.34 SCI Input/Output Timing: Clocked Synchronous Mode

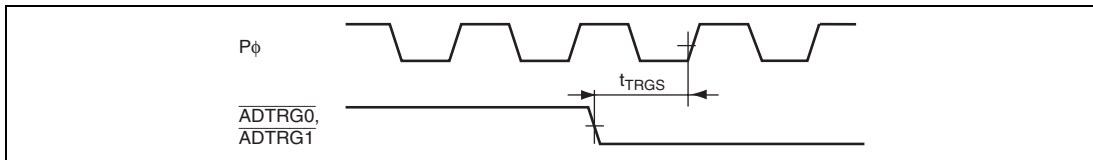

Figure 27.35 A/D Converter External Trigger Input Timing

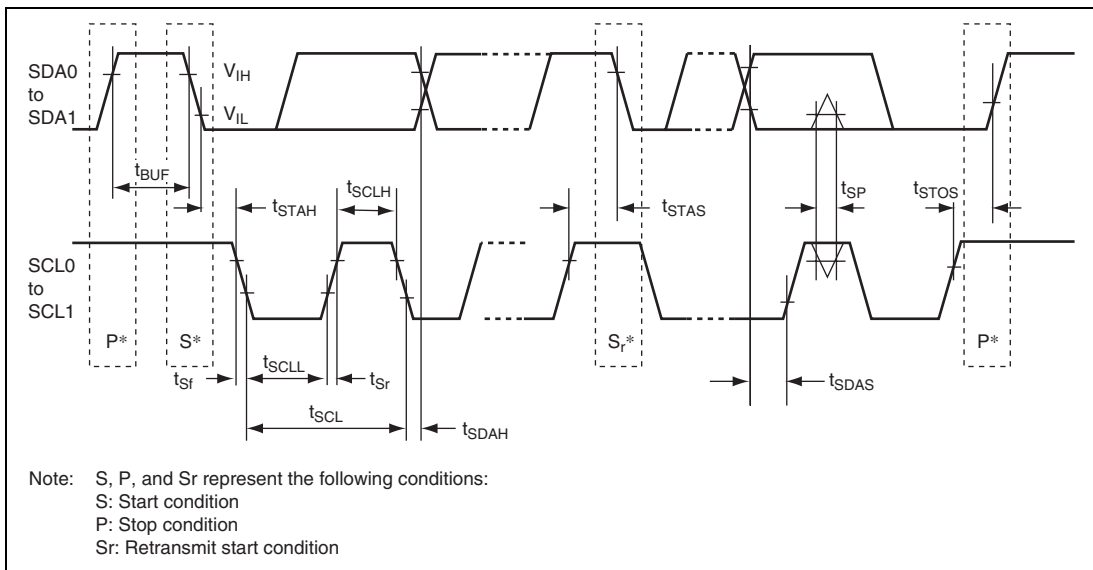

Figure 27.36 I²C Bus Interface 2 Input/Output Timing (Option)

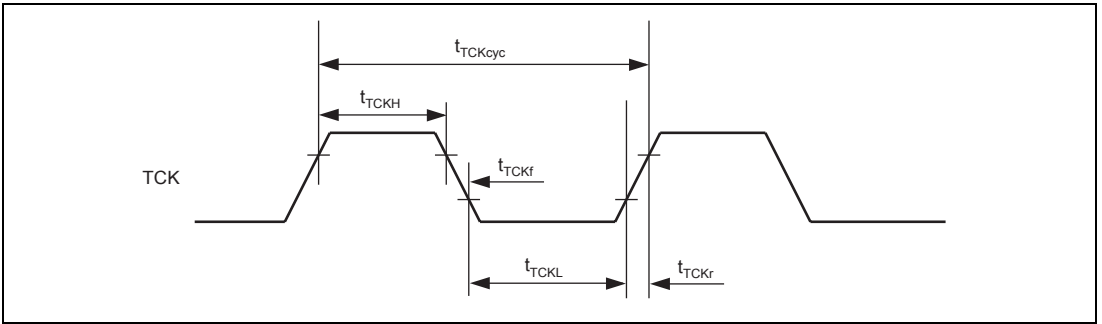

Figure 27.37 Boundary Scan TCK Timing

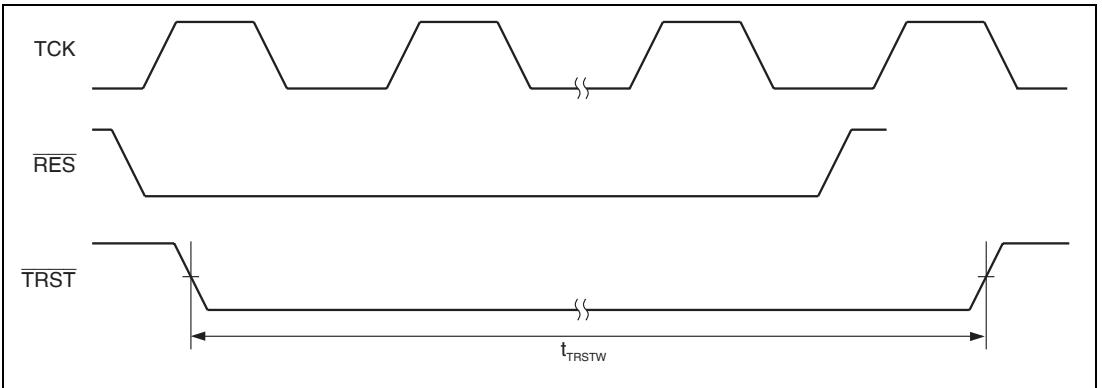

Figure 27.38 Boundary Scan \overline{TRST} Timing

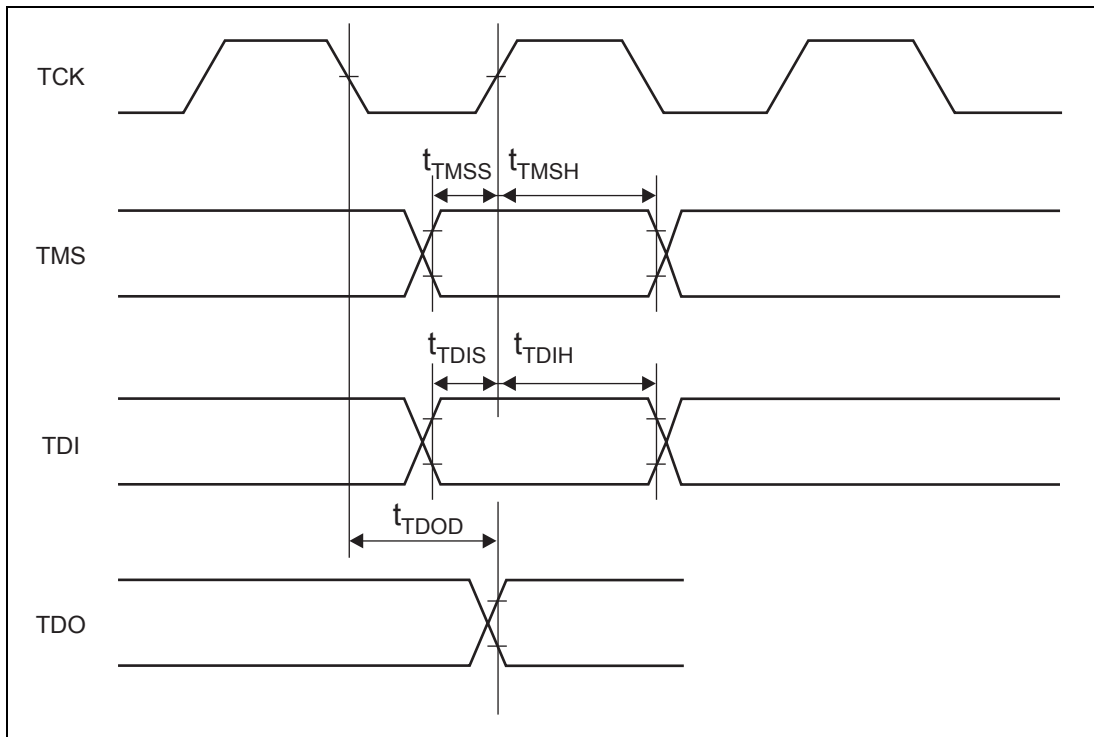

Figure 27.39 Boundary Scan Input/Output Timing

27.5 A/D Conversion Characteristics

Table 27.11 A/D Conversion Characteristics

Conditions: $V_{CC} = PLLV_{CC} = 3.0\text{ V to }3.6\text{ V}^*$, $AV_{CC} = 3.0\text{ V to }3.6\text{ V}$,
 $V_{ref} = 3.0\text{ V to }AV_{CC}$, $V_{SS} = PLLV_{SS} = AV_{SS} = 0\text{ V}$, $P\phi = 8\text{ MHz to }35\text{ MHz}$,
 $T_a = -20^\circ\text{C to }+75^\circ\text{C}$ (regular specifications),
 $T_a = -40^\circ\text{C to }+85^\circ\text{C}$ (wide-range specifications)

Item	Min.	Typ.	Max.	Unit
Resolution	10	10	10	Bit
Conversion time	2.7	—	—	μs
Analog input capacitance	—	—	20	pF
Permissible signal source impedance	—	—	5	k Ω
Nonlinearity error	—	—	± 7.5	LSB
Offset error	—	—	± 7.5	LSB
Full-scale error	—	—	± 7.5	LSB
Quantization error	—	± 0.5	—	LSB
Absolute accuracy	—	—	± 8.0	LSB

Note: * $V_{CC}=PLLV_{CC}=2.95\text{ to }3.6\text{V}$ in the H8SX/1638L Group.

27.6 D/A Conversion Characteristics

Table 27.12 D/A Conversion Characteristics

Conditions: $V_{CC} = PLLV_{CC} = 3.0\text{ V to }3.6\text{ V}^*$, $AV_{CC} = 3.0\text{ V to }3.6\text{ V}$, $V_{ref} = 3.0\text{ V to }AV_{CC}$,
 $V_{SS} = PLLV_{SS} = AV_{SS} = 0\text{ V}$, $P\phi = 8\text{ MHz to }35\text{ MHz}$,
 $T_a = -20^\circ\text{C to }+75^\circ\text{C}$ (regular specifications),
 $T_a = -40^\circ\text{C to }+85^\circ\text{C}$ (wide-range specifications)

Item	Min.	Typ.	Max.	Unit	Test Conditions
Resolution	8	8	8	Bit	
Conversion time	—	—	10	μs	20-pF capacitive load
Absolute accuracy	—	± 2.0	± 3.0	LSB	2-M Ω resistive load
	—	—	± 2.0	LSB	4-M Ω resistive load

Note: * $V_{CC}=PLLV_{CC}=2.95\text{ to }3.6\text{V}$ in the H8SX/1638L Group.

27.7 Flash Memory Characteristics

Table 27.13 Flash Memory Characteristics

Conditions: $V_{CC} = PLLV_{CC} = 3.0\text{ V to }3.6\text{ V}^{*1}$, $AV_{CC} = 3.0\text{ V to }3.6\text{ V}$, $V_{ref} = 3.0\text{ V to }AV_{CC}$,
 $V_{SS} = PLLV_{SS} = AV_{SS} = 0\text{ V}$,

Operating temperature range during programming/erasing:

Operating temperature range; $T_a = 0^\circ\text{C to }+75^\circ\text{C}$ (regular specifications),

$T_a = 0^\circ\text{C to }+85^\circ\text{C}$ (wide-range specifications)

Operating voltage range; $V_{CC} = PLLV_{CC} = 3.0\text{ V to }3.6\text{ V}$,

$AV_{CC} = 3.0\text{ V to }3.6\text{ V}$, $V_{ref} = 3.0\text{ V to }AV_{CC}$, $V_{SS} = PLLV_{SS} = AV_{SS} = 0\text{ V}$

Item	Symbol	Min.	Typ.	Max.	Unit	Test Conditions
Programming time ^{*2, *3, *5}	t_p	—	1	10	ms/128 bytes	
Erasure time ^{*2, *3, *5}	t_E	—	40	130	ms/4 kbyte-block	
			300	800	ms/32 kbyte-block	
			600	1500	ms/64 kbyte-block	
Programming time (total) ^{*2, *3, *5}	Σt_p	—	2.3	6	H8SX/1632, H8SX1632L s/256 kbytes	$T_a = 25^\circ\text{C}$, for all 0s
			4.5	12	H8SX/1634, H8SX1634L s/512 kbytes	
			9.0	24	H8SX/1638, H8SX1638L s/1 M byte	
Erasure time (total) ^{*2, *3, *5}	Σt_E	—	2.3	6	H8SX/1632, H8SX/1632L s/256 kbytes	$T_a = 25^\circ\text{C}$
			4.5	12	H8SX/1634, H8SX/1634L s/512 kbytes	
			9.0	24	H8SX/1638, H8SX/1638L s/1 M byte	

Item	Symbol	Min.	Typ.	Max.	Unit	Test Conditions
Programming, Erasure time (total)* ² , * ³ , * ⁵	Σ_{IPE}	—	4.6	12	H8SX/1632, H8SX/1632L s/256 kbytes	$T_a = 25^\circ\text{C}$
		—	9.0	24	H8SX/1634, H8SX/1634L s/512 kbytes	
		—	18.0	48	H8SX/1638, H8SX/1638L s/1 M byte	
Overwrite count	N_{WEC}	100* ⁴	—	—	Times	
Data save time* ⁵	T_{DRP}	10	—	—	Years	

- Notes: 1. $V_{\text{CC}} = \text{PLL}V_{\text{CC}} = 2.95$ to 3.6V in the H8SX/1638L Group.
2. Programming time and erase time depend on data in the flash memory.
3. Programming time and erase time do not include time for data transfer.
4. All the characteristics after programming are guaranteed within this value (guaranteed value is from 1 to Min. value).
5. Characteristics when programming is performed within the Min. value

27.8 Power-On Reset Circuit and Voltage-Detection Circuit Characteristics (H8SX/1638L Group)

Table 27.14 Power-On Reset Circuit and Voltage-Detection Circuit Characteristics

Conditions: $V_{\text{CC}} = \text{PLL}V_{\text{CC}} = V_{\text{SS}} = \text{PLL}V_{\text{SS}} = \text{AV}_{\text{SS}} = 0\text{V}$,
 $T_a = -20^\circ\text{C}$ to $+75^\circ\text{C}$ (regular specifications),
 $T_a = -40^\circ\text{C}$ to $+85^\circ\text{C}$ (wide-range specifications)

Item	Sym- bol	Min.	Typ.	Max.	Unit	Test Conditions	
Voltage detection level	Voltage detection circuit (LVD)	V_{det}	3.00	3.10	3.20	V	Figure 27.41
	Power-on reset (POR)	V_{POR}	2.48	2.58	2.68		Figure 27.40
Internal reset time	t_{POR}	20	35	50	ms	Figure 27.40,	
Power-off time*	t_{VOF}	200	—	—	us	Figure 27.41	

Note: * Power-off time (t_{VOF}) is the time over which V_{CC} is lower than minimum value of the voltage-detection level of the POR and LVD.

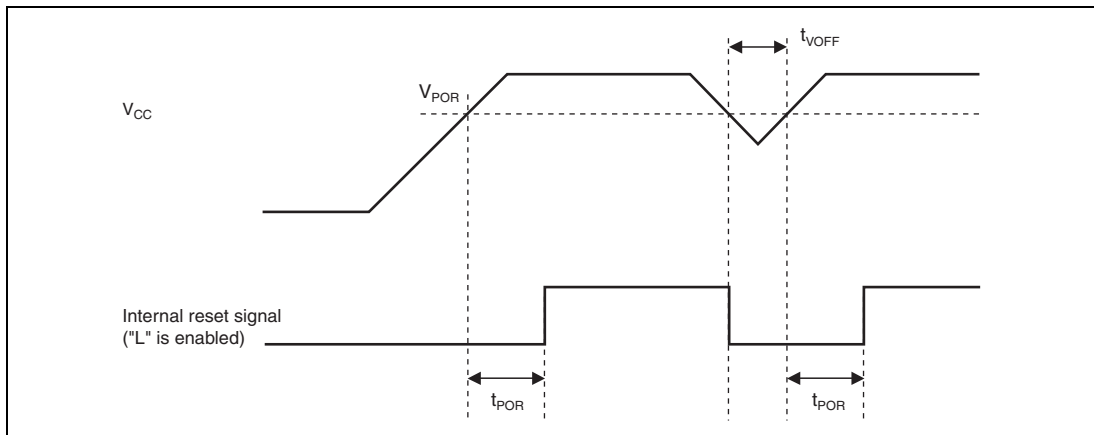

Figure 29.57 Power-on Reset Timing

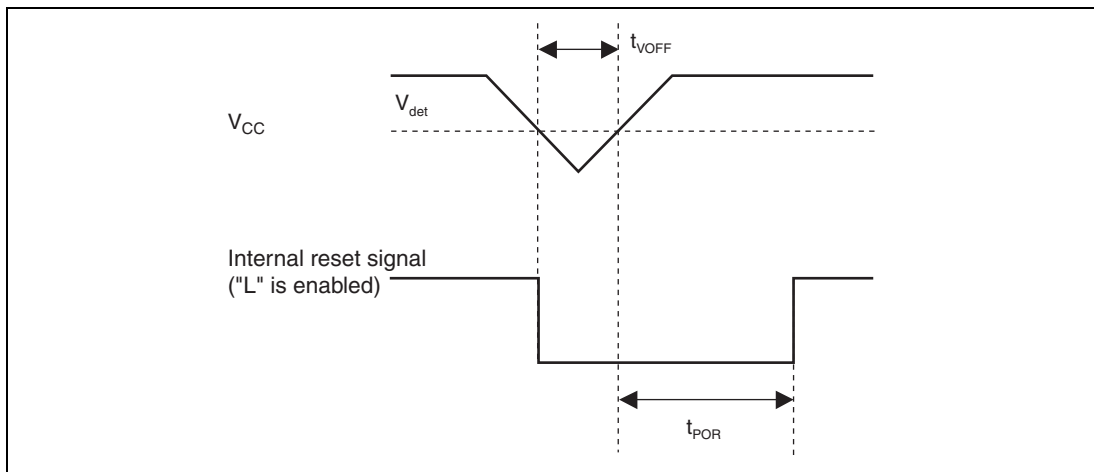

Figure 29.58 Voltage Detection Circuit Timing

Appendix

A. Port States in Each Pin State

Table A.1 Port States in Each Pin State

Port Name	MCU Operating Mode	Reset	Hardware Standby Mode	Deep Software Standby Mode IOKEEP = 1/0		Software Standby Mode		Bus Released State
				OPE = 1	OPE = 0	OPE = 1	OPE = 0	
Port 1	All	Hi-Z	Hi-Z	Keep	Keep	Keep	Keep	Keep
Port 2	All	Hi-Z	Hi-Z	Keep	Keep	Keep	Keep	Keep
Port 3	All	Hi-Z	Hi-Z	Keep	Keep	Keep	Keep	Keep
P55 to P50	All	Hi-Z	Hi-Z	Hi-Z	Hi-Z	Hi-Z	Hi-Z	Keep
P56/ AN6/ DA0/ IRQ6-B	All	Hi-Z	Hi-Z	Hi-Z	Hi-Z	[DAOE0 = 1] Keep [DAOE0 = 0] Hi-Z	[DAOE0 = 1] Keep [DAOE0 = 0] Hi-Z	Keep
P57/ AN7/ DA1/ IRQ7-B	All	Hi-Z	Hi-Z	Hi-Z	Hi-Z	[DAOE1 = 1] Keep [DAOE1 = 0] Hi-Z	[DAOE1 = 1] Keep [DAOE1 = 0] Hi-Z	Keep
P65 to P60	All	Hi-Z	Hi-Z	Keep	Keep	Keep	Keep	Keep
PA0/ BREQO/ BS-A	All	Hi-Z	Hi-Z	[BREQO output] Hi-Z [BS output] Keep [Other than above] Keep	[BREQO output] Hi-Z [BS output] Hi-Z [Other than above] Keep	[BREQO output] Hi-Z [BS output] Keep [Other than above] Keep	[BREQO output] Hi-Z [BS output] Hi-Z [Other than above] Keep	[BREQO output] BREQO [BS output] Hi-Z [Other than above] Keep
PA1/ BACK/ (RD/WR-A)	All	Hi-Z	Hi-Z	[BACK output] Hi-Z [RD/WR-A output] Keep [Other than above] Keep	[BACK output] Hi-Z [RD/WR-A output] Hi-Z [Other than above] Keep	[BACK output] Hi-Z [RD/WR-A output] Keep [Other than above] Keep	[BACK output] Hi-Z [RD/WR-A output] Hi-Z [Other than above] Keep	[BACK output] BACK [RD/WR-A output] Hi-Z [Other than above] Keep

Port Name	MCU Operating Mode	Reset	Hardware Standby Mode	Deep Software Standby Mode IOKEEP = 1/0		Software Standby Mode		Bus Released State
				OPE = 1	OPE = 0	OPE = 1	OPE = 0	
PA2/ BREQ/ WAIT	All	Hi-Z	Hi-Z	[BREQ input]	[BREQ input]	[BREQ input]	[BREQ input]	[BREQ input]
				Hi-Z	Hi-Z	Hi-Z	Hi-Z	Hi-Z
				[WAIT input]	[WAIT input]	[WAIT input]	[WAIT input]	[WAIT input]
				Hi-Z	Hi-Z	Hi-Z	Hi-Z	Hi-Z
				[Other than above]	[Other than above]	[Other than above]	[Other than above]	[Other than above]
				Keep	Keep	Keep	Keep	Hi-Z (WAIT)
PA3/ LLWR/ LLB	Single-chip mode (EXPE = 0)	Hi-Z	Hi-Z	Keep	Keep	Keep	Keep	Keep
	External extended mode (EXPE = 1)	H	Hi-Z	H	Hi-Z	H	Hi-Z	Hi-Z
PA4/ LHWR/ LUB	Single-chip mode (EXPE = 0)	Hi-Z	Hi-Z	Keep	Keep	Keep	Keep	Keep
	External extended mode (EXPE = 1)	H	Hi-Z	[LHWR, LUB output]	[LHWR, LUB output]	[LHWR, LUB output]	[LHWR, LUB output]	[LHWR, LUB output]
				H	Hi-Z	H	Hi-Z	Hi-Z
				[Other than above]	[Other than above]	[Other than above]	[Other than above]	[Other than above]
				Keep	Keep	Keep	Keep	Keep
PA5/RD	Single-chip mode (EXPE = 0)	Hi-Z	Hi-Z	Keep	Keep	Keep	Keep	Keep
	External extended mode (EXPE = 1)	H	Hi-Z	H	Hi-Z	H	Hi-Z	Hi-Z
PA6/ AS/ AH/ BS-B	Single-chip mode (EXPE = 0)	Hi-Z	Hi-Z	[AS, BS output]	[AS, AH, BS output]	[AS, BS output]	[AS, AH, BS output]	[AS, AH, BS output]
	External extended mode (EXPE = 1)	H	Hi-Z	H	Hi-Z	H	Hi-Z	Hi-Z
				[AH output]	[Other than above]	[AH output]	[Other than above]	[Other than above]
				L	Keep	L	Keep	Keep
				[Other than above]		[Other than above]	Keep	Keep
				Keep		Keep		

Port Name	MCU Operating Mode	Reset	Hardware Standby Mode	Deep Software Standby Mode IOKEEP = 1/0		Software Standby Mode		Bus Released State
				OPE = 1	OPE = 0	OPE = 1	OPE = 0	
PA7/B ϕ	Single-chip mode (EXPE = 0)	Hi-Z	Hi-Z	[Clock output]	[Clock output]	[Clock output]	[Clock output]	[Clock output]
	External extended mode (EXPE = 1)	Clock output	Hi-Z	H [Other than above] Keep	H [Other than above] Keep	H [Other than above] Keep	H [Other than above] Keep	Clock output [Other than above] Keep
PB0/ CS0/ CS4/ CS5-B	Single-chip mode (EXPE = 0)	Hi-Z	Hi-Z	[$\overline{\text{CS}}$ output] H	[$\overline{\text{CS}}$ output] Hi-Z	[$\overline{\text{CS}}$ output] H	[$\overline{\text{CS}}$ output] Hi-Z	[$\overline{\text{CS}}$ output] Hi-Z
	External extended mode (EXPE = 1)	H	Hi-Z	[Other than above] Keep	[Other than above] Keep	[Other than above] Keep	[Other than above] Keep	[Other than above] Keep
PB1/ CS1/ CS2-B/ CS5-A/ CS6-B/ CS7-B	All	Hi-Z	Hi-Z	[$\overline{\text{CS}}$ output] H	[$\overline{\text{CS}}$ output] Hi-Z	[$\overline{\text{CS}}$ output] H	[$\overline{\text{CS}}$ output] Hi-Z	[$\overline{\text{CS}}$ output] Hi-Z
				[Other than above] Keep	[Other than above] Keep	[Other than above] Keep	[Other than above] Keep	[Other than above] Keep
PB2/ CS2-A/ CS6-A	All	Hi-Z	Hi-Z	[$\overline{\text{CS}}$ output] H	[$\overline{\text{CS}}$ output] Hi-Z	[$\overline{\text{CS}}$ output] H	[$\overline{\text{CS}}$ output] Hi-Z	[$\overline{\text{CS}}$ output] Hi-Z
				[Other than above] Keep	[Other than above] Keep	[Other than above] Keep	[Other than above] Keep	[Other than above] Keep
PB3/ CS3/ CS7-A	All	Hi-Z	Hi-Z	[$\overline{\text{CS}}$ output] H	[$\overline{\text{CS}}$ output] Hi-Z	[$\overline{\text{CS}}$ output] H	[$\overline{\text{CS}}$ output] Hi-Z	[$\overline{\text{CS}}$ output] Hi-Z
				[Other than above] Keep	[Other than above] Keep	[Other than above] Keep	[Other than above] Keep	[Other than above] Keep
Port D	External extended mode (EXPE = 1)	L	Hi-Z	Keep	Hi-Z	Keep	Hi-Z	Hi-Z
	ROM enabled extended mode	Hi-Z	Hi-Z	Keep	[Address output] Hi-Z [Other than above] Keep	Keep [Address output] Hi-Z [Other than above] Keep	[Address output] Hi-Z [Other than above] Keep	[Address output] Hi-Z [Other than above] Keep
	Single-chip mode (EXPE = 0)	Hi-Z	Hi-Z	Keep	Keep	Keep	Keep	Keep

Port Name	MCU Operating Mode	Reset	Hardware Standby Mode	Deep Software Standby Mode IOKEEP = 1/0		Software Standby Mode		Bus Released State
				OPE = 1	OPE = 0	OPE = 1	OPE = 0	
Port E	External extended mode (EXPE = 1)	L	Hi-Z	Keep	Hi-Z	Keep	Hi-Z	Hi-Z
	ROM enabled extended mode	Hi-Z	Hi-Z	Keep	[Address output] Hi-Z [Other than above] Keep	Keep	[Address output] Hi-Z [Other than above] Keep	[Address output] Hi-Z [Other than above] Keep
	Single-chip mode (EXPE = 0)	Hi-Z	Hi-Z	Keep	Keep	Keep	Keep	Keep
PF3 to PF0	External extended mode (EXPE = 1)	L	Hi-Z	Keep	Hi-Z	Keep	Hi-Z	Hi-Z
	ROM enabled extended mode	Hi-Z	Hi-Z	Keep	[Address output] Hi-Z [Other than above] Keep	Keep	[Address output] Hi-Z [Other than above] Keep	[Address output] Hi-Z [Other than above] Keep
	Single-chip mode (EXPE = 0)	Hi-Z	Hi-Z	Keep	Keep	Keep	Keep	Keep
PF7 to PF4	External extended mode (EXPE = 1)	L/ Hi-Z*	Hi-Z	Keep	[Address output] Hi-Z [Other than above] Keep	Keep	[Address output] Hi-Z [Other than above] Keep	[Address output] Hi-Z [Other than above] Keep
	Single-chip mode (EXPE = 0)	Hi-Z	Hi-Z	Keep	Keep	Keep	Keep	Keep
	Port H	Single-chip mode (EXPE = 0)	Hi-Z	Hi-Z	Keep	Keep	Keep	Keep
Port I	External extended mode (EXPE = 1)	Hi-Z	Hi-Z	Hi-Z	Hi-Z	Hi-Z	Hi-Z	Hi-Z
	Single-chip mode (EXPE = 0)	Hi-Z	Hi-Z	Keep	Keep	Keep	Keep	Keep
		8-bit bus mode 16-bit bus mode	Hi-Z	Hi-Z	Hi-Z	Hi-Z	Hi-Z	Hi-Z

Port Name	MCU Operating Mode	Reset	Hardware Standby Mode	Deep Software Standby Mode IOKEEP = 1/0		Software Standby Mode		Bus Released State
				OPE = 1	OPE = 0	OPE = 1	OPE = 0	
Port J	Hi-Z	Hi-Z	Hi-Z	Keep	Keep	Keep	Keep	Keep
Port K	Hi-Z	Hi-Z	Hi-Z	Keep	Keep	Keep	Keep	Keep

[Legend]

H: High-level output

L: Low-level output

Keep: Input pins become high-impedance, output pins retain their state.

Hi-Z: High impedance

B. Product Lineup

Product Classification	Product Model	Marking	Package (Package Code)
H8SX/1632	R5F61632	R5F61632FPV	PLQP0120LA-A (FP-120BV) *
H8SX/1634	R5F61634	R5F61634FPV	PLQP0120LA-A (FP-120BV) *
H8SX/1638	R5F61638	R5F61638FPV	PLQP0120LA-A (FP-120BV) *
H8SX/1632L	R5F61632L	R5F61632LFPV	PLQP0120LA-A (FP-120BV) *
H8SX/1634L	R5F61634L	R5F61634LFPV	PLQP0120LA-A (FP-120BV) *
H8SX/1638L	R5F61638L	R5F61638LFPV	PLQP0120LA-A (FP-120BV) *

Note: * Pb-free version

C. Package Dimensions

For the package dimensions, data in the Renesas IC Package General Catalog has priority.

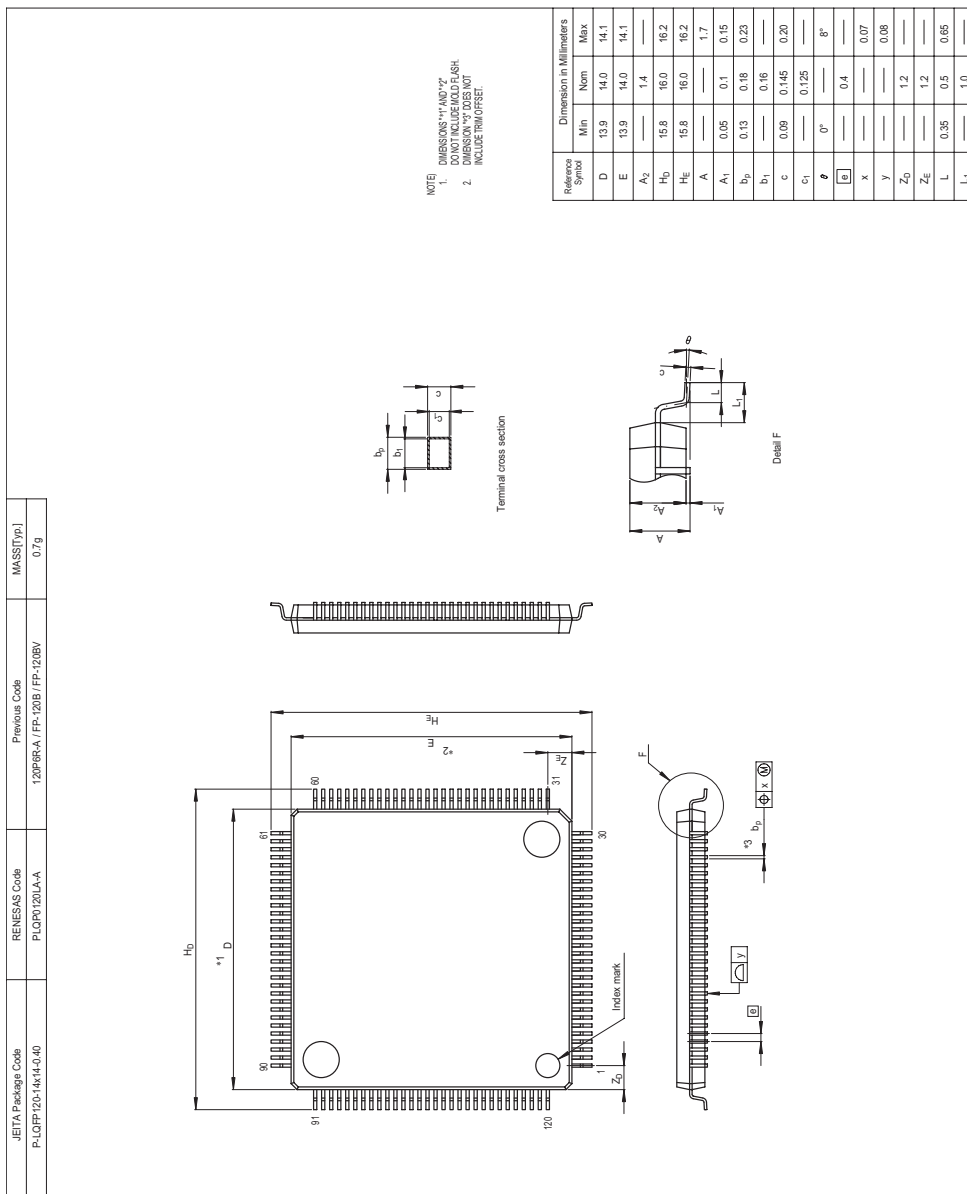

Figure C.1 Package Dimensions (FP-120BV)

D. Treatment of Unused Pins

The treatments of unused pins are listed in table D.1

Table D.1 Treatment of Unused Pins

Pin Name	Mode 4	Mode 5	Mode 6	Mode 3, 7
RES	• Connect this pin to Vcc via a pull-up resistor *			
STBY	• Connect this pin to Vcc via a pull-up resistor			
EMLE	• Connect this pin to Vss via a pull-down resistor			
MD2 to MD0	(Always used as mode pins)			
NMI	• Connect this pin to VCC via a pull-up resistor			
EXTAL	(Always used as a clock pin)			
XTAL	• Leave this pin open			
$\overline{\text{WDTOVF}}$	• Leave this pin open			
Port 1	• Connect these pins to VCC via a pull-up resistor or to VSS via a pull-down resistor, respectively			
Port 2				
Port 3				
Port 6				
PA2 to PA0				
PB3 to PB1				
PF7 to PF5				
Port J				
Port K				
Port 5				

Pin Name	Mode 4	Mode 5	Mode 6	Mode 3, 7
PA7	• This pin is left open in the initial state for the $B\phi$ output.			• Connect these pins to VCC via a pull-up resistor or to VSS via a pull-down resistor, respectively
PA6	• This pin is left open in the initial state for the \overline{AS} output.			
PA5	• This pin is left open in the initial state for the \overline{RD} output.			
PA4	• This pin is left open in the initial state for the \overline{LHWR} output.			
PA3	• This pin is left open in the initial state for the \overline{LLWR} output.			
PB0	• This pin is left open in the initial state for the $\overline{CS0}$ output.			
Port D Port E PF4 to PF0	• These pins are left open in the initial state for the address output.			
Port H	(Used as a data bus)			
Port I	(Used as a data bus)	• Connect these pins to VCC via a pull-up resistor or to VSS via a pull-down resistor, respectively, in the initial state for the general input.		
Vref	• Connect this pin to AVcc			

- Notes:
1. Do not change the initial value (input-buffer disabled) of PnICR, where n corresponds to an unused pin.
 2. When the pin function is changed from its initial state, use a pull-up or pull-down resistor as needed
- * Always used as a reset signal input pin in case of the H8SX/1638 Group.

Main Revisions and Additions in this Edition

Common revised items due to the version upgrade from Rev.1.00 to Rev.2.00

Item	Page	Revision (See Manual for Details)
All	—	Group Name Added: H8SX/1638L Group

Item	Page	Revision (See Manual for Details)
All	—	Amended: Section and Figure numbers are amended due to the addition of the sections below. (1) Voltage Detection Circuit (LVD) added to the Section 5 Structure of the Rev. 2.00 1. Overview 2. CPU 3. MCU Operating Modes 4. Resets 5. Voltage Detection Circuit (LVD) 6. Exception Handling 7. Interrupt Controller 8. User Break Controller (UBC) 9. Bus Controller (BSC) 10. DMA Controller (DMAC) 11. Data Transfer Controller (DTC) 12. I/O Ports 13. 16-Bit Timer Pulse Unit (TPU) 14. Programmable Pulse Generator (PPG) 15. 8-bit Timer (TMR) 16. Watch Dog Timer (WDT) 17. Serial Communication Interface (SCI, IrDA, CRC) 18. I2C Bus Interface 2 (IIC2) 19. A/D Converter 20. D/A Converter 21. RAM 22. Flash Memory 23. Boundary Scan 24. Clock Pulse Generator 25. Power-Down Modes 26. List of Registers 27. Electrical Characteristics Appendix

Item	Page	Revision (See Manual for Details)
Section 1 Overview	2	Amended
1.1.2 Overview of Functions		<ul style="list-style-type: none"> CPU Supports multiply-and-accumulate instructions (16 x 16 + 42 → 42 bits)
Table 1.1 Overview of Functions	3	Interrupt controller (INTC) Number of internal interrupt sources H8SX/1638 Group: 110 pins H8SX/1638L Group: 111 pins
1.2 List of Products	9	Deleted
Figure 1.1 How to Read the Product Name Code		H8SX/1638 Group
1.4.3 Pin Functions	20	Amended
Table 1.5 Pin Functions		Description of 16-bit timer pulse unit (TPU) Signals for TGRA_0 to TGRD_0. These pins are used as input capture inputs, output compare outputs, or PWM outputs.
Section 3 MCU Operating Modes	77	Amended
3.4.1 Address Map		H'FEC000 to H'FEE000 of each mode
Figure 3.1 Address Map in Each Operating Mode of H8SX/1638, 1638L (1)		[Before amendment] Access prohibited area → [After amendment] Reserved area* ³
Figure 3.1 Address Map in Each Operating Mode of H8SX/1638, 1638L (2)	78	Amended and added H'FEC000 to H'FE000 of each mode [Before amendment] Access prohibited area → [After amendment] Reserved area* ¹ Note 1 is added.
Figure 3.2 Address Map in Each Operating Mode of H8SX/1634 and H8SX/1634L (1)	79	Amended H'FEC000 to H'FE2000 of each mode [Before amendment] Access prohibited area → [After amendment] Reserved area* ³
Figure 3.2 Address Map in Each Operating Mode of H8SX/1634 and H8SX/1634L (2)	80	Amended H'FEC000 to H'FF2000 of each mode [Before amendment] Access prohibited area → [After amendment] Reserved area* ¹ Note 1 is added

Item	Page	Revision (See Manual for Details)
Figure 3.3 Address Map in Each Operating Mode of H8SX/1632 and H8SX/1632L (1)	81	Amended H'FEC000 to H'FE6000 of each mode [Before amendment] Access prohibited area → [After amendment] Reserved area* ³
Figure 3.3 Address Map in Each Operating Mode of H8SX/1632 and H8SX/1632L (2)	82	Amended H'FEC000 to H'F6000 of each mode [Before amendment] Access prohibited area → [After amendment] Reserved area* ¹ Note 1 is added
Section 4 Reset 4.3.1 Reset Status Register (RSTSR)	86	Amended Description of Bit 7 [Before amendment] External interrupt source → [After amendment] Interrupt source
Section 7 Interrupt Controller 7.3.4 IRQ Enable Register (IER)	124	Amended IER enables interrupt requests IRQ15 to IRQ0.
7.3.6 IRQ Status Register (ISR)	131, 132	Amended Bit 15 [Before amendment] IRQn → [After amendment] IRQ15 Bit 14 [Before amendment] IRQn → [After amendment] IRQ14
Section 10 DMA Controller (DMAC) 10.1 Features	276	Added <ul style="list-style-type: none"> Module stop state can be set.
10.3.5 DMA Block Size Register (DBSR)	284	Amended Bit table Initial Value of the Bit 31-16 and 15-0 [Before amendment] Undefined → [After amendment] All 0
10.5.8 Priority of Channels Figure 10.22 Example of Timing for Channel Priority	327	Amended Positions of dotted lines have been corrected.

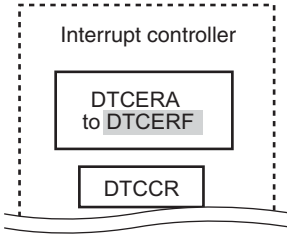
Item	Page	Revision (See Manual for Details)
10.5.11 Bus Cycles in Single Address Mode (3) Activation Timing by DREQ Falling Edge Figure 10.36 Example of Transfer in Single Address Mode Activated by DREQ Falling Edge	340	Amended Wave-form of B ϕ has been corrected.
Section 11. Data Transfer Controller (DTC) Figure 11.1 Block Diagram of DTC	354	Amended
		 <p>The diagram shows a dashed box labeled 'Interrupt controller'. Inside this box, there is a rectangular block labeled 'DTCERA to DTCERF'. Below this block, and still within the dashed box, is another rectangular block labeled 'DTCCR'. A wavy line is drawn below the 'DTCCR' block.</p>
11.9.3 DMAC Transfer End Interrupt	386	Added When the DTC is activated by a DMAC transfer end interrupt, even if DISEL = 0, an automatic clearing of the relevant activation source flag is not automatically cleared by the DTC. Therefore, write 1 to the DTE bit by the DTC transfer and clear the activation source flag to 0.
11.9.9 Points for Caution when Overwriting DTCER.	388	Added

Item	Page	Revision (See Manual for Details)
Section 12 I/O Port	392	Amended
Table 12.1 Port Functions		Bit 2 of Port A $\overline{\text{WAIT}}$ Bit 1 of Port A ($\text{RD}/\overline{\text{WR}}$)
12.1.1 Data Direction Register (PnDDR)	397	Added Notes on the port 6 and port B
12.1.2 Data Register (PnDR) (n = 1, 2, 3, 6, A, B, D, E, F, and H to K)	398	Added Notes on the port 6 and port B
12.1.3 Port Register (PORTn) (n = 1, 2, 3, 5, 6, A, B, D, E, F, and H to K)	398	Added Notes on the port 6 and port B
12.1.4 Input Buffer Control Register (PnICR) (n = 1, 2, 3, 5, 6, A, B, D, E, F, and H to K)	399	Added Notes on the port 6 and port B
12.2 Output Buffer Control	418	Amended (2) $\text{PA6}/\overline{\text{AS}}/\overline{\text{AH}}/\overline{\text{BS-B}}$
12.2.6 Port A		[Before amendment] $\overline{\text{BSB_OE}}$ → [After amendment] $\overline{\text{BS-B_OE}}$
	420	Amended (6) $\text{PA2}/\overline{\text{BREQ}}/\overline{\text{WAIT}}$
	421	Amended (7) $\text{PA1}/\overline{\text{BACK}}/(\text{RD}/\overline{\text{WR}})$
	422	Amended (8) $\text{PA0}/\overline{\text{BREQO}}/\overline{\text{BS-A}}$ [Before amendment] $\overline{\text{BSA_OE}}$ → [After amendment] $\overline{\text{BS-A_OE}}$
Table 12.5 Available Output Signals and Settings in Each Port	440 to 448	Replaced Replaced due to the correction of an error.
12.3.6 Port Function Control Register 7 (PFCR7)	456	Amended Descriptions for bits 7,6,5, and 4 [Before amendment] 00: Setting prohibited → [After amendment] 00: Setting invalid

Item	Page	Revision (See Manual for Details)
12.3.7 Port Function Control Register 9 (PFCR9)	457	Amended Descriptions for bit 7 in the bit table Selects TIOCA5 function
12.3.9 Port Function Control Register B (PFCRB)	461	Amended Bit name in the bit table ITS13
Section 13 16-Bit Timer Pulse Unit (TPU)	473	Amended
13.1 Features		
Figure 13.2 Block Diagram of TPU (Unit 1)		
		<p>The diagram shows a block labeled 'Control logic for channels 9 to 11'. This block is connected to three channels: Channel 9, Channel 10, and Channel 11. Each channel contains a set of registers: TCR, TMDR, TIOR, TIER, TIORH, and TSR. Bidirectional arrows indicate communication between the control logic and each channel.</p>
13.3.4 Timer Interrupt Enable Register (TIER)	507	Amended Bit name in the bit table Bit 2 TGIEC
13.4.6 Phase Counting Mode	537, 538	Amended
(c) Phase counting mode 3		Figure 13.28 Example of Phase Counting Mode 3 Operation
(d) Phase counting mode 4		Figure 13.29 Example of Phase Counting Mode 4 Operation
Section 16. Watchdog Timer (WDT)	633	Deleted
16.3.3 Reset Control/Status Register (RSTCSR)		Description below for bit 7 is deleted (When the CPU is used to clear this flag by writing 0 while the corresponding interrupt is enabled, be sure to read the flag after writing 0 to it.)

Item	Page	Revision (See Manual for Details)
Section 17 Serial Communications Interface (SCI, IrDA, CRC)	662	Amended The bit name FER
17.3.7 Serial Status Register (SSR)		
17.3.12 IrDA Control Register (IrCR)	685	Amended Description for the Bit 7 in the register table 1: TxD5/IrTxD and RxD5/IrRxD pins are operated as IrTxD and IrRxD
17.7.8 Clock Output Control	720	Deleted 1. Set the data register (DR) and data direction register (DDR) corresponding to the SCK pin to the values for the output fixed state in software standby mode. (SCI_0, 1, 2, and 4 only)
<ul style="list-style-type: none"> • At mode switching <ul style="list-style-type: none"> — At transition from smart card interface mode to software standby mode 		
Section 18 I ² C Bus Interface 2 (IIC2)	739	Added <ul style="list-style-type: none"> • Module stop function setting
18.1 Features		
18.3.5 I ² C Bus Status Register (ICSR)	752	Deleted The description below for the bit 1 is deleted: [Clearing condition] When 0 is written to this bit after reading AAS = 1 (When the CPU is used to clear this flag by writing 0 while the corresponding interrupt is enabled, be sure to read the flag after writing 0 to it.)
	753	Deleted The description below for the bit 0 is deleted: [Clearing condition] When 0 is written to this bit after reading ADZ = 1 (When the CPU is used to clear this flag by writing 0 while the corresponding interrupt is enabled, be sure to read the flag after writing 0 to it.)
18.7 Usage Notes	771	Added 6. Module stop function setting

Item	Page	Revision (See Manual for Details)
Section 19 A/D Converter	779	Added
19.3.2 A/D Control/Status Register for Unit 0 (ADCSR_0)		Descriptions for bit 5 in the register table: Note: Do not write to ADST when activation is by an external trigger. For details, see section 19.7.3, Notes on A/D activation by an External Trigger.
19.3.3 A/D Control/Status Register for Unit 1 (ADCSR_1)	781	Added
		Descriptions for bit 5 in the register table: Note: Do not write to ADST when activation is by an external trigger. For details, see section 19.7.3, Notes on A/D activation by an External Trigger.
19.3.4 A/D Control Register (ADCR_0) Unit 0	783	Amended and added
		Descriptions for bits 7,6, and 0 in the register table: 001: External trigger disabled Note: Do not write to ADST when activation is by an external trigger. For details, see section 19.7.3, Notes on A/D activation by an External Trigger.
19.3.5 A/D Control Register (ADCR_1) Unit 1	785	Amended and added
		Descriptions for bits 7,6, and 0 in the register table: 011: External trigger disabled Note: Do not write to ADST when activation is by an external trigger. For details, see section 19.7.3, Notes on A/D activation by an External Trigger.
19.4.3 Input Sampling and A/D Conversion Time	792	Replaced
		Table 19.3 A/D Conversion Characteristics (EXCKS = 0) Table 19.4 A/D Conversion Characteristics (EXCKS = 1: Unit 1)
19.7.3 Notes on A/D Activation by an External Trigger	798, 799	Added
Section 20 D/A Converter	808	Amended
20.5.2 D/A Output Hold Function in Software Standby Mode		When this LSI make a transition to software standby mode with D/A conversion enabled, the D/A outputs are retained,
20.5.3 Notes on Deep Software Standby Mode	808	Added

Item	Page	Revision (See Manual for Details)
Section 22 Flash Memory	825	Added Bit 0 R/W*
22.7.1 Programming/Erasing Interface Registers		Note: This is a write-only bit. This bit is always read as 0.
22.7.2 Programming/Erasing Interface Parameters	837	Amended FPEFEQ sets the operating frequency of the CPU. The operating frequency available in this LSI ranges from 8 MHz to 50 MHz.
(3) Flash Program/Erase Frequency Parameter (FPEFEQ: General Register ER0 of CPU)		
(5) Flash Multipurpose Data Destination Parameter (FMPDR: General Register ER0 of CPU)	840	Amended MOD31 to MOD0
22.8.2 User Program Mode	851	Amended
(2) Programming Procedure in User Program Mode		6. The operating frequency of the CPU is set in the FPEFEQ parameter for initialization. The settable operating frequency of the FPEFEQ parameter ranges from 8 to 50 MHz.
22.14 Usage Notes	903	Amended
		5. Do not turn off the Vcc power supply nor remove the chip from the PROM programmer during programming/erasure in which a high voltage is applied to the flash memory. Doing so may damage the flash memory permanently. If a reset is input, the reset must be released after the reset input period of at least 100ms.
	903	7. At powering on the Vcc power supply, fix the RES pin to low and set the flash memory to hardware protection state. This power on timing must also be satisfied at a power-off and power-on caused by a power failure and other factors.
23. Boundary Scan	910 to	Amended
23.4.3 Boundary Scan Register (JTBSR)	916	Table 23.4 Boundary Scan Register Add "from TDI" to the item in the table and delete "from TDI" and "to TDO" from the pin names of the item in the table.
23.5.2 Commands	920	Amended (5) CLAMP (Instruction Code: B'0010)

Item	Page	Revision (See Manual for Details)
Section 25 Power-Down Modes	935	<p>Deleted</p> <p>Table 25.1 States of Operation</p> <p>Notes 4. "Functioning" or "Halted" is selectable through the setting of bits MSTPA9 and MSTPA8 in MSTPCRA. However, output from pins are disabled even if the "Functioning" is selected.</p>
25.2.4 Deep Standby Control Register (DPSBYCR)	945	<p>Amended</p> <p>DPSBYCR controls deep software standby mode.</p> <p>DPSBYCR is initialized by input of the reset signal on the RES pin, but is not initialized by the internal reset signal upon exit from deep software standby mode.</p>
	945	<p>Amended</p> <p>Descriptions for bit 7 in the register table:</p> <p>When deep software standby mode is canceled due to an interrupt, this bit remains at 1.</p>
	946	<p>Amended</p> <p>Descriptions for bit 5 in the register table</p> <p>On-chip RAM Power Off 2</p> <p>RAMCUT 2 to 0 control the internal power supply to the on-chip RAM in deep software standby mode. For details, see descriptions of the RAMCUT0 bit.</p> <p>Descriptions for bit 4 in the register table</p> <p>On-chip RAM Power Off 1</p> <p>RAMCUT 2 to 0 control the internal power supply to the on-chip RAM in deep software standby mode. For details, see descriptions of the RAMCUT0 bit.</p> <p>Descriptions for bit 0 in the register table</p> <p>On-chip RAM Power Off 0</p> <p>RAMCUT 2 to 0 control the internal power supply to the on-chip RAM in deep software standby mode.</p>

Item	Page	Revision (See Manual for Details)
25.2.5 Deep Standby Wait Control Register (DPSWCR)	947	<p data-bbox="431 142 534 162">Amended</p> <p data-bbox="431 181 1130 264">DPSWCR selects the time for which the MCU waits until the clock settles when deep software standby mode is canceled by an external interrupt.</p> <p data-bbox="431 284 1130 363">DPSWCR is initialized by input of the reset signal on the RES pin, but is not initialized by the internal reset signal upon exit from deep software standby mode.</p>
	948	<p data-bbox="431 379 534 400">Amended</p> <p data-bbox="431 419 924 440">Descriptions for bits 5 to 0 in the register table:</p> <p data-bbox="431 459 1130 539">These bits select the time for which the MCU waits until the clock settles when deep software standby mode is canceled by an external interrupt.</p>
25.2.6 Deep Standby Interrupt Enable Register (DPSIER)	949	<p data-bbox="431 560 534 580">Amended</p> <p data-bbox="431 600 1084 651">DPSIER enables or disables interrupts to clear deep software standby mode.</p> <p data-bbox="431 670 1130 751">DPSIER is initialized by input of the reset signal on the RES pin, but is not initialized by the internal reset signal upon exit from deep software standby mode.</p>
	949	<p data-bbox="431 767 534 788">Amended</p> <p data-bbox="431 807 868 828">Descriptions for bit 3 in the register table:</p> <p data-bbox="431 847 1084 898">Enables or disables exit from deep software standby mode by IRQ3-A.</p> <p data-bbox="431 917 994 968">0: Disables exit from deep software standby mode by IRQ3-A.</p> <p data-bbox="431 987 994 1038">1: Enables exit from deep software standby mode by IRQ3-A.</p>

Item	Page	Revision (See Manual for Details)
25.2.6 Deep Standby Interrupt Enable Register (DPSIER)	950	Amended Descriptions for bit 2 in the register table: Enables or disables exit from deep software standby mode by IRQ2-A . 0: Disables exit from deep software standby mode by IRQ2-A . 1: Enables exit from deep software standby mode by IRQ2-A .
	950	Amended Descriptions for bit 1 in the register table: Enables or disables exit from deep software standby mode by IRQ1-A . 0: Disables exit from deep software standby mode by IRQ1-A . 1: Enables exit from deep software standby mode by IRQ1-A .
	950	Amended Descriptions for bit 0 in the register table: Enables or disables exit from deep software standby mode by IRQ0-A . 0: Disables exit from deep software standby mode by IRQ0-A . 1: Enables exit from deep software standby mode by IRQ0-A .

Item	Page	Revision (See Manual for Details)
25.2.7 Deep Standby Interrupt Flag Register (DPSIFR)	951	<p data-bbox="431 142 534 165">Amended</p> <p data-bbox="431 181 1100 352">DPSIFR is used to request an exit from deep software standby mode. When the interrupt specified in DPSIEGR is generated, the applicable bit in DPSIFR is set to 1. The bit is set to 1 even when an interrupt is generated in the modes other than deep software standby. Therefore, a transition to deep software standby should be made after this register bits are cleared to 0.</p> <p data-bbox="431 368 1084 421">DPSIFR is not initialized by the internal reset signal upon exit from deep software standby mode.</p>
	952	<p data-bbox="431 437 912 461">Descriptions for bit 3 R/W in the register table</p> <p data-bbox="431 477 955 529">R/(W)^{*1} IRQ3-A input specified in DPSIEGR is generated.</p> <p data-bbox="431 585 912 609">Descriptions for bit 2 R/W in the register table</p> <p data-bbox="431 625 955 678">R/(W)^{*1} IRQ2-A input specified in DPSIEGR is generated.</p> <p data-bbox="431 734 912 758">Descriptions for bit 1 R/W in the register table</p> <p data-bbox="431 774 955 826">R/(W)^{*1} IRQ1-A input specified in DPSIEGR is generated.</p> <p data-bbox="431 882 912 906">Descriptions for bit 0 R/W in the register table</p> <p data-bbox="431 922 955 975">R/(W)^{*1} IRQ0-A input specified in DPSIEGR is generated.</p>

Item	Page	Revision (See Manual for Details)
25.2.8 Deep Standby Interrupt Edge Register (DPSIEGR)	953	Amended DPSIEGR selects the rising or falling edge to clear deep software standby mode. DPSIEGR is not initialized by the internal reset signal upon exit from deep software standby mode.
	953, 954	Descriptions for bit 3 in the register table IRQ3-A input specified in DPSIEGR is generated.
		Descriptions for bit 2 in the register table IRQ2-A input specified in DPSIEGR is generated.
		Descriptions for bit 1 in the register table IRQ1-A input specified in DPSIEGR is generated.
		Descriptions for bit 0 in the register table IRQ0-A input specified in DPSIEGR is generated.
25.2.9 Reset Status Register (RSTSR)	954	Amended The DPSRSTF bit in RSTSR indicates that deep software standby mode has been canceled by an interrupt. RSTSR is not initialized by the internal reset signal upon exit from deep software standby mode.
	955	Descriptions for bit 7 in the register table Indicates that deep software standby mode has been canceled by an interrupt source specified in DPSIER or DPSIEGR and an internal reset is generated. [Setting condition] Deep software standby mode is canceled by an interrupt source.
25.2.10 Deep Standby Backup Register (DPSBKRn)	956	Amended DPSBKRn (n = 15 to 0) is a 16-byte readable/writable register to store data during deep software standby mode. Although data in on-chip RAM is not retained in deep software standby mode, data in this register is retained. DPSBKRn (n=15 to 0) is not initialized by the internal reset signal upon exit from deep software standby mode.

Item	Page	Revision (See Manual for Details)
------	------	-----------------------------------

25.9.4 Timing Sequence at Power-On	977	Figure 25.9 shows the timing sequence at power-on. At power-on, the $\overline{\text{RES}}$ pin must be driven low with the $\overline{\text{STBY}}$ pin driven high for a given time in order to clear the reset state.
------------------------------------	-----	---

Item **Page** **Revision (See Manual for Details)**

Section 26. List of Registers

988 Added

28.1 Register Addresses (Address Order)

Break address register AH	BARAH	16	H'FFFA00	UBC	16	2 ϕ /2 ϕ
Break address register AL	BARAL	16	H'FFFA02	UBC	16	2 ϕ /2 ϕ
Break address mask register AH	BAMRAH	16	H'FFFA04	UBC	16	2 ϕ /2 ϕ
Break address mask register AL	BAMRAL	16	H'FFFA06	UBC	16	2 ϕ /2 ϕ
Break address register BH	BARBH	16	H'FFFA08	UBC	16	2 ϕ /2 ϕ
Break address register BL	BARBL	16	H'FFFA0A	UBC	16	2 ϕ /2 ϕ
Break address mask register BH	BAMRBH	16	H'FFFA0C	UBC	16	2 ϕ /2 ϕ
Break address mask register BL	BAMRBL	16	H'FFFA0E	UBC	16	2 ϕ /2 ϕ
Break address register CH	BARCH	16	H'FFFA10	UBC	16	2 ϕ /2 ϕ
Break address register CL	BARCL	16	H'FFFA12	UBC	16	2 ϕ /2 ϕ
Break address mask register CH	BAMRCH	16	H'FFFA14	UBC	16	2 ϕ /2 ϕ
Break address mask register CL	BAMRCL	16	H'FFFA16	UBC	16	2 ϕ /2 ϕ
Break address register DH	BARDH	16	H'FFFA18	UBC	16	2 ϕ /2 ϕ
Break address register DL	BARDL	16	H'FFFA1A	UBC	16	2 ϕ /2 ϕ
Break address mask register DH	BAMRDH	16	H'FFFA1C	UBC	16	2 ϕ /2 ϕ
Break address mask register DL	BAMRDL	16	H'FFFA1E	UBC	16	2 ϕ /2 ϕ
Break control register A	BRCRA	16	H'FFFA28	UBC	16	2 ϕ /2 ϕ
Break control register B	BRCRB	16	H'FFFA2C	UBC	16	2 ϕ /2 ϕ
Break control register C	BRCRC	16	H'FFFA30	UBC	16	2 ϕ /2 ϕ
Break control register D	BRCRD	16	H'FFFA34	UBC	16	2 ϕ /2 ϕ

Item

Page Revision (See Manual for Details)

Section 26. List of Registers

992 Added

Deep standby backup register 0	DPSBKR0	8	H'FFBF0	SYSTEM	8	2 ϕ /3I ϕ
Deep standby backup register 1	DPSBKR1	8	H'FFBF1	SYSTEM	8	2 ϕ /3I ϕ
Deep standby backup register 2	DPSBKR2	8	H'FFBF2	SYSTEM	8	2 ϕ /3I ϕ
Deep standby backup register 3	DPSBKR3	8	H'FFBF3	SYSTEM	8	2 ϕ /3I ϕ
Deep standby backup register 4	DPSBKR4	8	H'FFBF4	SYSTEM	8	2 ϕ /3I ϕ
Deep standby backup register 5	DPSBKR5	8	H'FFBF5	SYSTEM	8	2 ϕ /3I ϕ
Deep standby backup register 6	DPSBKR6	8	H'FFBF6	SYSTEM	8	2 ϕ /3I ϕ
Deep standby backup register 7	DPSBKR7	8	H'FFBF7	SYSTEM	8	2 ϕ /3I ϕ
Deep standby backup register 8	DPSBKR8	8	H'FFBF8	SYSTEM	8	2 ϕ /3I ϕ
Deep standby backup register 9	DPSBKR9	8	H'FFBF9	SYSTEM	8	2 ϕ /3I ϕ
Deep standby backup register 10	DPSBKR10	8	H'FFBFA	SYSTEM	8	2 ϕ /3I ϕ
Deep standby backup register 11	DPSBKR11	8	H'FFBFB	SYSTEM	8	2 ϕ /3I ϕ
Deep standby backup register 12	DPSBKR12	8	H'FFBFC	SYSTEM	8	2 ϕ /3I ϕ
Deep standby backup register 13	DPSBKR13	8	H'FFBFD	SYSTEM	8	2 ϕ /3I ϕ
Deep standby backup register 14	DPSBKR14	8	H'FFBFE	SYSTEM	8	2 ϕ /3I ϕ
Deep standby backup register 15	DPSBKR15	8	H'FFBFF	SYSTEM	8	2 ϕ /3I ϕ

Item

Page Revision (See Manual for Details)

26.2 Register Bits

1005, Added

1006

List of register bits

BARAH	BARA31	BARA30	BARA29	BARA28	BARA27	BARA26	BARA25	BARA24	UBC
	BARA23	BARA22	BARA21	BARA20	BARA19	BARA18	BARA17	BARA16	
BARAL	BARA15	BARA14	BARA13	BARA12	BARA11	BARA10	BARA9	BARA8	
	BARA7	BARA6	BARA5	BARA4	BARA3	BARA2	BARA1	BARA0	
BAMRAH	BAMRA31	BAMRA30	BAMRA29	BAMRA28	BAMRA27	BAMRA26	BAMRA25	BAMRA24	
	BAMRA23	BAMRA22	BAMRA21	BAMRA20	BAMRA19	BAMRA18	BAMRA17	BAMRA16	
BAMRAL	BAMRA15	BAMRA14	BAMRA13	BAMRA12	BAMRA11	BAMRA10	BAMRA9	BAMRA8	
	BAMRA7	BAMRA6	BAMRA5	BAMRA4	BAMRA3	BAMRA2	BAMRA1	BAMRA0	
BARBH	BARB31	BARB30	BARB29	BARB28	BARB27	BARB26	BARB25	BARB24	
	BARB23	BARB22	BARB21	BARB20	BARB19	BARB18	BARB17	BARB16	
BARBL	BARB15	BARB14	BARB13	BARB12	BARB11	BARB10	BARB9	BARB8	
	BARB7	BARB6	BARB5	BARB4	BARB3	BARB2	BARB1	BARB0	
BAMRBH	BAMRB31	BAMRB30	BAMRB29	BAMRB28	BAMRB27	BAMRB26	BAMRB25	BAMRB24	
	BAMRB23	BAMRB22	BAMRB21	BAMRB20	BAMRB19	BAMRB18	BAMRB17	BAMRB16	
BAMRBL	BAMRB15	BAMRB14	BAMRB13	BAMRB12	BAMRB11	BAMRB10	BAMRB9	BAMRB8	
	BAMRB7	BAMRB6	BAMRB5	BAMRB4	BAMRB3	BAMRB2	BAMRB1	BAMRB0	
BARC	BARC31	BARC30	BARC29	BARC28	BARC27	BARC26	BARC25	BARC24	
	BARC23	BARC22	BARC21	BARC20	BARC19	BARC18	BARC17	BARC16	

26.2 Register Bits

1006 Added

BARCL	BARC15	BARC14	BARC13	BARC12	BARC11	BARC10	BARC9	BARC8	UBC
	BARC7	BARC6	BARC5	BARC4	BARC3	BARC2	BARC1	BARC0	
BAMRCH	BAMRC 31	BAMRC 30	BAMRC 29	BAMRC 28	BAMRC 27	BAMRC 26	BAMRC 25	BAMRC 24	
	BAMRC 23	BAMRC 22	BAMRC 21	BAMRC 20	BAMRC 19	BAMRC 18	BAMRC 17	BAMRC 16	
BAMRCL	BAMRC 15	BAMRC 14	BAMRC 13	BAMRC 12	BAMRC 11	BAMRC 10	BAMRC 9	BAMRC 8	
	BAMRC7	BAMRC6	BAMRC5	BAMRC4	BAMRC3	BAMRC2	BAMRC1	BAMRC0	
BARDH	BARD31	BARD30	BARD29	BARD28	BARD27	BARD26	BARD25	BARD24	
	BARD23	BARD22	BARD21	BARD20	BARD19	BARD18	BARD17	BARD16	
BARDL	BARD15	BARD14	BARD13	BARD12	BARD11	BARD10	BARD9	BARD8	
	BARD7	BARD6	BARD5	BARD4	BARD3	BARD2	BARD1	BARD0	
BAMRDH	BAMRD 31	BAMRD 30	BAMRD 29	BAMRD 28	BAMRD 27	BAMRD 26	BAMRD 25	BAMRD 24	
	BAMRD 23	BAMRD 22	BAMRD 21	BAMRD 20	BAMRD 19	BAMRD 18	BAMRD 17	BAMRD 16	
BAMRDL	BAMRD 15	BAMRD 14	BAMRD 13	BAMRD 12	BAMRD 11	BAMRD 10	BAMRD 9	BAMRD 8	
	BAMRD7	BAMRD6	BAMRD5	BAMRD4	BAMRD3	BAMRD2	BAMRD1	BAMRD0	
BRCRA	—	—	CMFCPA	—	CPA2	CPA1	CPA0	—	
	—	—	IDA1	IDA0	RWA1	RWA0	—	—	
BRCRB	—	—	CMFCPB	—	CPB2	CPB1	CPB0	—	
	—	—	IDB1	IDB0	RWB1	RWB0	—	—	
BRCRC	—	—	CMFCPC	—	CPC2	CPC1	CPC0	—	
	—	—	IDC1	IDC0	RWC1	RWC0	—	—	
BRCRD	—	—	DMFCPD	—	CPD2	CPD1	CPD0	—	
	—	—	IDD1	IDD0	RWD1	RWD0	—	—	

Item

Page Revision (See Manual for Details)

26.2 Register Bits

1011 Added

DPSBKR	BKUP07	BKUP06	BKUP05	BKUP04	BKUP03	BKUP02	BKUP01	BKUP00	SYSTEM
0									
DPSBKR	BKUP17	BKUP16	BKUP15	BKUP14	BKUP13	BKUP12	BKUP11	BKUP10	
1									
DPSBKR	BKUP27	BKUP26	BKUP25	BKUP24	BKUP23	BKUP22	BKUP21	BKUP20	
2									
DPSBKR	BKUP37	BKUP36	BKUP35	BKUP34	BKUP33	BKUP32	BKUP31	BKUP30	
3									
DPSBKR	BKUP47	BKUP46	BKUP45	BKUP44	BKUP43	BKUP42	BKUP41	BKUP40	
4									
DPSBKR	BKUP57	BKUP56	BKUP55	BKUP54	BKUP53	BKUP52	BKUP51	BKUP50	
5									
DPSBKR	BKUP67	BKUP66	BKUP65	BKUP64	BKUP63	BKUP62	BKUP61	BKUP60	
6									
DPSBKR	BKUP77	BKUP76	BKUP75	BKUP74	BKUP73	BKUP72	BKUP71	BKUP70	
7									
DPSBKR	BKUP87	BKUP86	BKUP85	BKUP84	BKUP83	BKUP82	BKUP81	BKUP80	
8									
DPSBKR	BKUP97	BKUP96	BKUP95	BKUP94	BKUP93	BKUP92	BKUP91	BKUP90	
9									
DPSBKR	BKUP107	BKUP106	BKUP105	BKUP104	BKUP103	BKUP102	BKUP101	BKUP100	
10									
DPSBKR	BKUP117	BKUP116	BKUP115	BKUP114	BKUP113	BKUP112	BKUP111	BKUP110	
11									
DPSBKR	BKUP127	BKUP126	BKUP125	BKUP124	BKUP123	BKUP122	BKUP121	BKUP120	
12									
DPSBKR	BKUP137	BKUP136	BKUP135	BKUP134	BKUP133	BKUP132	BKUP131	BKUP130	
13									
DPSBKR	BKUP147	BKUP146	BKUP145	BKUP144	BKUP143	BKUP142	BKUP141	BKUP140	
14									
DPSBKR	BKUP157	BKUP156	BKUP155	BKUP154	BKUP153	BKUP152	BKUP151	BKUP150	
15									

1017 Amended

SCKCR	PSTOP1	—	■	—	—	ICK2	ICK1	ICK0
	—	PCK2	PCK1	PCK0	—	BCK2	BCK1	BCK0

26.3 Register States in
Each Operating Mode

1029 Added

BARAH	Initialized	—	—	—	—	Initialized ⁹¹	Initialized	UBC
BARAL	Initialized	—	—	—	—	Initialized ⁹¹	Initialized	
BAMRAH	Initialized	—	—	—	—	Initialized ⁹¹	Initialized	
BAMRAL	Initialized	—	—	—	—	Initialized ⁹¹	Initialized	
BARBH	Initialized	—	—	—	—	Initialized ⁹¹	Initialized	
BARBL	Initialized	—	—	—	—	Initialized ⁹¹	Initialized	
BAMRBH	Initialized	—	—	—	—	Initialized ⁹¹	Initialized	
BAMRBL	Initialized	—	—	—	—	Initialized ⁹¹	Initialized	
BARCH	Initialized	—	—	—	—	Initialized ⁹¹	Initialized	
BARCL	Initialized	—	—	—	—	Initialized ⁹¹	Initialized	
BAMRCH	Initialized	—	—	—	—	Initialized ⁹¹	Initialized	
BAMRCL	Initialized	—	—	—	—	Initialized ⁹¹	Initialized	
BARDH	Initialized	—	—	—	—	Initialized ⁹¹	Initialized	
BARDL	Initialized	—	—	—	—	Initialized ⁹¹	Initialized	
BAMRDH	Initialized	—	—	—	—	Initialized ⁹¹	Initialized	
BAMRDL	Initialized	—	—	—	—	Initialized ⁹¹	Initialized	
BRCRA	Initialized	—	—	—	—	Initialized ⁹¹	Initialized	
BRCRB	Initialized	—	—	—	—	Initialized ⁹¹	Initialized	
BRCRC	Initialized	—	—	—	—	Initialized ⁹¹	Initialized	
BRCRD	Initialized	—	—	—	—	Initialized ⁹¹	Initialized	

Item **Page** **Revision (See Manual for Details)**

26.3 Register States in Each Operating Mode

1033 Added

DPSBKR0	Initialized	—	—	—	—	—	Initialized	SYSTEM
DPSBKR1	Initialized	—	—	—	—	—	Initialized	
DPSBKR2	Initialized	—	—	—	—	—	Initialized	
DPSBKR3	Initialized	—	—	—	—	—	Initialized	
DPSBKR4	Initialized	—	—	—	—	—	Initialized	
DPSBKR5	Initialized	—	—	—	—	—	Initialized	
DPSBKR6	Initialized	—	—	—	—	—	Initialized	
DPSBKR7	Initialized	—	—	—	—	—	Initialized	
DPSBKR8	Initialized	—	—	—	—	—	Initialized	
DPSBKR9	Initialized	—	—	—	—	—	Initialized	
DPSBKR10	Initialized	—	—	—	—	—	Initialized	
DPSBKR11	Initialized	—	—	—	—	—	Initialized	
DPSBKR12	Initialized	—	—	—	—	—	Initialized	
DPSBKR13	Initialized	—	—	—	—	—	Initialized	
DPSBKR14	Initialized	—	—	—	—	—	Initialized	
DPSBKR15	Initialized	—	—	—	—	—	Initialized	

26.3 Register States in Each Operating Mode

1036 Amended

DPSBYCR	Initialized	—	—	—	—	■	Initialized	SYSTEM
DPSWCR	Initialized	—	—	—	—	■	Initialized	
DPSIER	Initialized	—	—	—	—	■	Initialized	
DPSIFR	Initialized	—	—	—	—	■	Initialized	
DPSIEGR	Initialized	—	—	—	—	■	Initialized	

Section 27 Electrical Characteristics

1045 Amended

27.1 Absolute Maximum Ratings

Hardware standby mode	—	2	7	μA	$T_a \leq 50^\circ\text{C}$
	—	—	25		$50^\circ\text{C} < T_a$

Table 27.2
DC Characteristics (2)

Items revised or amended due to the addition of the H8SX/1638L

Item	Page	Revision (See Manual for Details)
All	—	Added The functions for H8SX/1638L Group are added to the corresponding sections. Details are noted as below: Note * : Supported only by the H8SX/1638L Group.
All	—	Added Below are the sections added and those functions are added to the corresponding sections due to the addition of modules. (1) Section 5 Voltage Detection Circuit (LVD)
Cover	—	Replaced Product names due to the addition of the H8SX/1638L Group.
How to Use This Manual	—	Replaced Name of group: H8SX/1638L Group
Section 1 Overview	1	Replaced
1.1 Features		
1.1.2 Overview of Functions	2 to 7	Replaced Table 1.1 Overview of Functions
	8	Added Table 1.2 Comparison of Support Functions in the H8SX/1638 Group and the 1638L Group.
1.2 List of Products	9	Replaced Table 1.3 List of Products Figure 1.1 How to Read the Product Name Code
1.3 Block Diagram	11	Replaced Figure 1.2 Block Diagram
1.4.2 Correspondence between Pin Configuration and Operating Modes	13	Replaced Table 1.4 Pin Configuration in Each Operating Mode (H8SX/1638 Group and H8SX/1638L Group)

Item	Page	Revision (See Manual for Details)
Section 3 MCU Operating Modes	77 to 82	Replaced
3.4.1 Address Map		<p>Figure 3.1 Address Map in Each Operating Mode of H8SX/1638 Group and 1638L Group (1)</p> <p>Figure 3.1 Address Map in Each Operating Mode of H8SX/1638 Group and 1638L Group (2)</p> <p>Figure 3.2 Address Map in Each Operating Mode of H8SX/1634 Group and 1634L Group (1)</p> <p>Figure 3.2 Address Map in Each Operating Mode of H8SX/1634 Group and 1634L Group (2)</p> <p>Figure 3.3 Address Map in Each Operating Mode of H8SX/1632 Group and 1632L Group (1)</p> <p>Figure 3.3 Address Map in Each Operating Mode of H8SX/1632 Group and 1632L Group (2)</p>
Section 4 Reset	83, 84	Replaced
4.1 Types of Reset		<p>Table 4.1 Reset Names And Sources</p> <p>Figure 4.1 Block Diagram of Reset Circuit</p> <p>Replaced due to the addition of the power-on reset and voltage-monitoring reset.</p>
4.3.1 Reset Status Register (RSTSR)	86, 87	<p>Replaced</p> <p>Replaced due to the addition of the power-on reset and voltage-monitoring reset.</p>
4.5 Power-on Reset (POR) (H8SX/1638L Group)	89	<p>Added</p> <p>Added due to the addition of the power-on reset.</p>
4.6 Power Supply Monitoring Reset (H8SX/1638L Group)	90	<p>Added</p> <p>Added due to the addition of the power supply monitoring reset.</p>
4.9 Determination of Reset Generation Source	92	<p>Replaced</p> <p>Replaced due to the addition of the power supply monitoring reset.</p>
Section 6 Exception Handling	110	Replaced
6.6.1 Interrupt Sources		<p>Table 6.7 Interrupt Sources</p> <p>Replaced due to the addition of the LVD.</p>

Item	Page	Revision (See Manual for Details)
Section 7 Interrupt Controller	118	Replaced
7.1 Features		Figure 7.1 Block Diagram of Interrupt Controller Replaced due to the addition of the LVD.
7.3 Register Description	124,	Replaced
7.3.4 IRQ Enable Register (IER)	125	Replaced due to the addition of the LVD.
7.3.5 IRQ Sense Control Registers H and L (ISCRH, ISCR L)	126 to 130	Replaced Replaced due to the addition of the LVD.
7.3.6 IRQ Status Register (ISR)	131 to 133	Replaced Replaced due to the addition of the LVD.
7.5 Interrupt Exception Handling Vector Table	137 to 142	Replaced Table 7.2 Interrupt Sources, Vector Address Offsets, and Interrupt Priority Replaced due to the addition of the LVD.
Section 12. I/O Ports	461,	Replaced
12.3.9 Port Function Control Register B (PFCRB)	462	Replaced due to the addition of the LVD.
Section 21. RAM	809	Replaced 21. RAM Replaced due to the addition of the H8SX/1638L Group.
Section 22. Flash Memory	811	Replaced
22.1 Features		<ul style="list-style-type: none"> ROM size Replaced due to the addition of the H8SX/1638L Group.
Section 25. Power-Down Modes	936	Replaced
25.1 Features		Table 25.1 States of Operation Figure 25.1 Mode Transitions Replaced due to the addition of the LVD.
25.2.6 Deep Standby Interrupt Enable Register (DPSIER)	949	Added Bit 5 and Bit 4 Added due to the addition of the LVD.
25.2.7 Deep Standby Interrupt Flag Register (DPSIFR)	951	Replaced Bit 5 and Bit 4 Replaced due to the addition of the LVD.

Item	Page	Revision (See Manual for Details)
25.2.9 Reset Status Register (RSTSR)	955	Added <ul style="list-style-type: none"> H8SX1638 Group H8SX1638L Group Added due to the addition of the LVD.
25.5.2 Exit from Sleep Mode	958	Replaced <p>Replaced due to the addition of the LVD and power-on reset.</p>
25.6 All-Module-Clock-Stop Mode	959	Replaced <p>Replaced due to the addition of the LVD.</p>
25.7.2 Exit from Software Standby Mode	960	Replaced <ol style="list-style-type: none"> Exit from software standby mode by interrupt Replaced due to the addition of the 32K timer, voltage-monitoring reset, and power-on reset.
	960, 961	Added <ol style="list-style-type: none"> Exit from voltage monitoring reset*² Exit from power-on reset*² Added due to the addition of the voltage monitoring reset and power on reset.
25.8.1 Entry to Deep Software Standby Mode	964	Replaced <p>Replaced due to the addition of the LVD.</p>
25.8.2 Exit from Deep Software Standby Mode	965	Replaced <ol style="list-style-type: none"> Exit from deep software standby mode by external interrupt pins Replaced due to the addition of the LVD and TM32K.
	965	Added <ol style="list-style-type: none"> Exit from deep software standby mode by a voltage-monitoring reset* Exit from power-on reset* Added due to the addition of the voltage monitoring reset and power-on reset.
25.9.4 Timing Sequence at Power-On	977	Replaced <p>Replaced due to the addition of the power-on reset.</p>
25.12.7 Conflict between a transition to deep software standby mode and interrupts	983	Replaced <p>Replaced due to the addition of the voltage monitoring interrupt.</p>

Item	Page	Revision (See Manual for Details)
Section 27 Electrical Characteristics	1044	Replaced
27.2 DC Characteristics	to 1046	Replaced due to the addition of the H8SX/1638L Group.
H8SX/1638 Group		
27.3 DC Characteristics	1047	Added
H8SX/1638L Group	to 1049	Added due to the addition of the H8SX/1638L Group.
27.4.1 Clock Timing	1050, 1051	Replaced Table 27.6 Conditions of clock timing Replaced due to the addition of the H8SX/1638L Group.
27.4.2 Control Signal Timing	1053	Replaced Table 27.7 Conditions of clock timing Replaced due to the addition of the H8SX/1638L Group.
27.4.3 Bus Timing	1054 to 1056	Replaced Table 27.8 Conditions of bus timing (1) Table 27.8 Conditions of bus timing (2) Replaced due to the addition of the H8SX/1638L Group.
27.4.4 DMAC Timing	1069	Replaced Table 27.9 Conditions of DMAC timing Replaced due to the addition of the H8SX/1638L Group.
27.5 A/D Conversion Characteristics	1080	Replaced Table 27.11 Conditions of A/D conversion characteristics Replaced due to the addition of the H8SX/1638L Group.
27.6 D/A Conversion Characteristics	1080	Replaced Table 27.12 Conditions of D/A conversion characteristics Replaced due to the addition of the H8SX/1638L Group.
27.7 Flash Memory Characteristics	1081, 1082	Replaced Replaced due to the addition of the H8SX/1638L Group.
27.8 Power-On Reset Circuit and Voltage-Detection Circuit Characteristics (H8SX/1638L Group)	1082, 1083	Replaced Replaced due to the addition of the power-on reset and the LVD.

Item	Page	Revision (See Manual for Details)
Appendix	1090	Replaced
B. Product Lineup		Replaced due to the addition of the H8SX/1638L Group.
D. Treatment of Unused Pins	1092, 1093	Replaced Replaced due to the addition of the H8SX/1638L Group.

Index

Numerics

0 output/1 output.....	517
0-output/1-output.....	517
16-bit access space.....	216
16-bit counter mode.....	620
16-bit timer pulse unit (TPU).....	467
8-bit access space.....	215
8-bit timers (TMR).....	595

A

A/D conversion accuracy.....	796
Absolute accuracy.....	796
Acknowledge.....	755
Address error.....	108
Address map.....	76
Address modes.....	301
Address/data multiplexed I/O interface.....	209, 244
All-module-clock-stop mode.....	934, 959
Area 0.....	210
Area 1.....	211
Area 2.....	211
Area 3.....	212
Area 4.....	212
Area 5.....	213
Area 6.....	214
Area 7.....	214
Area division.....	204
Asynchronous mode.....	686
AT-cut parallel-resonance type.....	927
Available output signal and settings in each port.....	440
Average transfer rate generator.....	642

B

B ϕ clock output control.....	981
Basic bus interface.....	208, 218
Big endian.....	207
Bit rate.....	669
Bit synchronous circuit.....	769
Block structure.....	817
Block transfer mode.....	307, 376
Boot mode.....	814, 843
Boundary scan commands.....	909
Buffer operation.....	522
Burst access mode.....	313
Burst ROM interface.....	208, 239
Bus access modes.....	312
Bus arbitration.....	270
Bus configuration.....	196
Bus controller (BSC).....	171
Bus cycle division.....	370
Bus width.....	207
Bus-released state.....	68
Byte control SRAM interface.....	208, 231

C

Cascaded connection.....	620
Cascaded operation.....	526
Chain transfer.....	377
Chip select signals.....	205
Clock pulse generator.....	923
Clock synchronization cycle (T _{sy}).....	198
Clocked synchronous mode.....	703
Communications protocol.....	876
Compare match A.....	618
Compare match B.....	619

Compare match count mode	621
Compare match signal	618
Counter operation	514
CPU priority control function over DTC and DMAC	152
CRC Operation Circuit	732
Crystal resonator	927
Cycle stealing mode	312

D

D/A converter	803
Data direction register	397
Data register	398
Data transfer controller (DTC)	353
Direct convention	711
DMA controller (DMAC)	275
Double-buffered structure	686
Download pass/fail result parameter	832
DTC vector address	365
DTC vector address offset	365
Dual address mode	301

E

Endian and data alignment	215
Endian format	207
Error protection	868
Error signal	711
Exception handling	101
Exception-handling state	68
Extended repeat area	299
Extended repeat area function	314
Extension of chip select (\overline{CS}) assertion period	228
External access bus	196
External bus	201
External bus clock ($B\phi$)	197, 923
External bus interface	206
External clock	928

External interrupts	135
---------------------------	-----

F

Flash erase block select parameter	841
Flash memory	811
Flash multipurpose address area parameter	839
Flash multipurpose data destination parameter	840
Flash pass and fail parameter	833
Flash program/erase frequency parameter	837, 851
Free-running count operation	515
Frequency divider	923, 929
Full address mode	363
Full-scale error	796

G

General illegal instructions	113
------------------------------------	-----

H

Hardware protection	867
Hardware standby mode	934, 976

I

I/O ports	389
I ² C bus format	755
I ² C bus interface2 (IIC2)	739
ID code	697
Idle cycle	254
Illegal instruction	113
Input buffer control register	399
Input capture function	518
Internal interrupts	136
Internal peripheral bus	196

Internal system bus	196
Interrupt	110
Interrupt control mode 0	143
Interrupt control mode 2	145
Interrupt controller.....	117
Interrupt exception handling sequence ...	147
Interrupt exception handling vector table	137
Interrupt response times.....	148
Interrupt sources	135
Interrupt sources and vector address offsets	137
Interval timer	636
Interval timer mode.....	636
Inverse convention.....	712
IRQn interrupts.....	135

J	
JTAG interface	773

L	
Little endian.....	207

M	
Mark state	686, 727
Master receive mode.....	758
Master transmit mode	756
MCU operating modes.....	69
Memory MAT configuration	816
Mode 2.....	74
Mode 4.....	74
Mode 5.....	75
Mode 6.....	75
Mode 7.....	75
Mode pin.....	69
Multi-clock mode	956
Multiprocessor bit.....	697

Multiprocessor communication function	697
--	-----

N	
NMI interrupt.....	135
Noise canceler.....	764
Nonlinearity error.....	796
Non-overlapping pulse output.....	585
Normal transfer mode	373
Normal transfer mode	305
Number of Access Cycles.....	208

O	
Offset addition	317
Offset error.....	796
On-board programming	843
On-board programming mode.....	811
On-chip baud rate generator.....	689
On-chip ROM disabled extended mode....	69
On-chip ROM enabled extended mode....	69
Open-drain control register	401
Oscillator.....	927
Output buffer control	401
Output trigger.....	584
Overflow	620, 634

P	
Package dimensions	1091, 1092
Parity bit.....	686
Periodic count operation	515
Peripheral module clock (P ϕ).....	197, 923
Phase counting mode	533
Pin assignments.....	12
Pin functions	18
PLL circuit	923, 929
Port function controller	449
Port register.....	398

Power-down modes	933
Procedure program	861
Processing states	68
Product lineup.....	1090
Program execution state.....	68
Program stop state	68
Programmable pulse generator (PPG)	559
Programmer mode	814, 874
Programming/erasing interface.....	820
Programming/erasing interface parameters.....	830
Programming/erasing interface register	823
Protection.....	867
Pull-up MOS control register.....	400
PWM modes	528

Q

Quantization error.....	796
-------------------------	-----

R

RAM.....	809
Read strobe (\overline{RD}) timing.....	227
Register addresses	986
Register Bits	1003
Register configuration in each port.....	396
Registers	
ABWCR	175, 994, 1016, 1035
ADCSR.....	779
ASTCR	176, 994, 1016, 1035
BCR1	188, 995, 1017, 1035
BCR2	190, 995, 1017, 1035
BROMCR.....	193, 995, 1017, 1035
BRR	669, 999, 1022, 1040
CCR.....	37
CPUPCR.....	121, 998, 1021, 1038
CRA.....	359
CRB.....	360

CRCCR.....	733
CRCDIR	734
CRCDOR.....	734
CSACR	183, 995, 1016, 1035
DACR	294, 993, 1012, 1034
DACR01	805, 999, 1022, 1039
DADR0.....	804, 999, 1022, 1039
DADR1.....	804, 999, 1022, 1039
DAR.....	359
DBSR.....	284, 993, 1012, 1033
DDAR.....	281, 993, 1011, 1033
DDR.....	397, 990, 1009, 1031
DMDR	285, 993, 1012, 1034
DMRSR	300
DOFR.....	282, 993, 1011, 1033
DPFR	832
DPSBYCR	995, 1018, 1036
DPSIEGR.....	995, 1018, 1036
DPSIER.....	995, 1018, 1036
DPSIFR.....	995, 1018, 1036
DPSWCR.....	995, 1018, 1036
DR.....	398, 998, 1021, 1039
DSAR.....	280, 992, 1011, 1033
DTCCR	361, 998, 1021, 1038
DT CER	360, 998, 1020, 1038
DTCR.....	283, 993, 1012, 1033
DTCVBR	363, 994, 1016, 1035
ENDIANCR.....	191, 995, 1017, 1035
EXR	38
FCCS.....	823, 995, 1017, 1036
FEBS.....	841
FECS.....	826, 995, 1017, 1036
FKEY	827, 995, 1018, 1036
FMATS	828
FMPAR.....	839
FMPDR.....	840
FPCS	826, 995, 1017, 1036
FPEFEQ.....	837, 851
FPPR	833
FTDAR.....	829, 995, 1018, 1036

General registers	35	PCR(PPG).....	987, 999, 1005, 1022,
ICCRA	743, 996, 1019, 1037	1028, 1039
ICCRB	744, 996, 1019, 1037	PFCR0.....	450, 992, 1010, 1032
ICDRR	754, 996, 1019, 1037	PFCR1.....	450, 992, 1010, 1032
ICDRS	754	PFCR2.....	452, 992, 1010, 1033
ICDRT	754, 996, 1019, 1037	PFCR4.....	453, 992, 1010, 1033
ICIER	747, 996, 1019, 1037	PFCR6.....	455, 992, 1010, 1033
ICMR	746, 996, 1019, 1037	PFCR7.....	456, 992, 1010, 1033
ICR	399, 990, 1009, 1031	PFCR9.....	457, 992, 1010, 1033
ICSR	750, 996, 1019, 1037	PFCRB.....	461, 992, 1010, 1033
IDLCR	186, 995, 1017, 1035	PFCRC	463, 992, 1010, 1033
IER.....	124, 998, 1021, 1038	PMR.....	577, 987, 999, 1005,
INTCR.....	120, 998, 1021, 1038	1022, 1028, 1039
IPR.....	122, 994, 1015, 1034	PODRH.....	567, 987, 999, 1005,
IrCR.....	685	1022, 1028, 1040
ISCRH.....	126, 994, 1016, 1035	PODRL.....	567, 987, 999, 1005,
ISCRL.....	126, 994, 1016, 1035	1022, 1028, 1040
ISR.....	131, 998, 1021, 1038	PORT	398, 998, 1021, 1038
MAC	39	RAMER	842, 995, 1017, 1035
MDCR	70, 995, 1017, 1036	RDNCR.....	182, 994, 1016, 1035
MPXCR.....	195, 995, 1017, 1035	RDR	649, 999, 1022, 1040
MRA	356	RSR.....	649
MRB	357	RSTCSR.....	633, 1000, 1023, 1040
MSTPCRA.....	940, 995, 1017, 1036	RSTSR	996, 1018, 1036
MSTPCRB.....	940, 995, 1017, 1036	SAR.....	358, 753, 996, 1019, 1037
MSTPCRC.....	943, 995, 1017, 1036	SBR.....	39
NDERH	565, 987, 999, 1005,	SBYCR	937, 995, 1017, 1036
.....	1022, 1028, 1039	SCKCR	924, 995, 1017, 1036
NDERL.....	565, 987, 999, 1005,	SCMR	668, 999, 1022, 1040
.....	1022, 1028, 1039	SCR.....	654, 999, 1022, 1040
NDRH.....	570, 988, 999, 1005,	SDBPR.....	909
.....	1022, 1029, 1040	SDBSR.....	910
NDRL	570, 988, 999, 1005,	SDID	917
.....	1022, 1029, 1040	SEMR.....	676, 996, 1018, 1036
ODR.....	401, 991, 1010, 1032	SMR.....	650, 999, 1022, 1040
PC	36	SRAMCR.....	192, 995, 1017, 1035
PCR.....	575	SSIER.....	134, 992, 1011, 1033
PCR (I/O port)	400	SSR	660, 999, 1022, 1040
PCR(I/O port)	991, 1010, 1032	SYSCR.....	72, 995, 1017, 1036

TCCR.....606, 1000, 1024, 1041
 TCNT..... 511
 TCNT (TMR)..... 603
 TCNT (WDT)..... 631
 TCNT(TMR)1000, 1024, 1041
 TCNT(TPU)989, 990, 1001, 1007,
1008, 1024, 1029, 1030,
 1031, 1041
 TCNT(WDT).....1000, 1023, 1040
 TCORA603, 1000, 1024, 1041
 TCRORB.....604, 1000, 1024, 1041
 TCR 481
 TCR (TMR)..... 604
 TCR(TMR).....1000, 1023, 1041
 TCR(TPU).....1000, 1006, 1008, 1024,
 1041
 TCSR (TMR)..... 611
 TCSR (WDT) 631
 TCSR(TMR).....1000, 1024, 1041
 TCSR(WDT)1000, 1023, 1040
 TDR650, 999, 1022, 1040
 TGR511, 989, 990, 1001,
1007, 1008, 1009, 1024,
1030, 1031, 1041
 TIER.....506, 989, 990, 1001,
1007, 1008, 1024, 1029,
1030, 1031, 1041
 TIOR.....488, 988, 989, 990,
1001, 1006, 1008, 1024,
1029, 1030, 1031, 1041
 TMDR486, 988, 989, 990,
1000, 1006, 1008, 1024,
1029, 1030, 1031, 1041
 TSR..... 507, 650
 TSR(TPU).....989, 990, 1001, 1007,
1008, 1024, 1029, 1030,
 1031, 1041
 TSTR512, 1000, 1024, 1041

TSYR 513, 1000, 1024, 1041
 VBR..... 39
 WTCRA..... 177, 994, 1016, 1035
 WTCRB 177, 994, 1016, 1035
 Repeat transfer mode 306, 374
 Reset 104
 Reset state 68
 Resolution 796

S

Sample-and-hold circuit..... 791
 Scan mode..... 788
 Serial communication interface (SCI)..... 641
 Short address mode 363
 Single address mode 302
 Single mode 787
 Slave receive mode 763
 Slave transmit mode..... 760
 Sleep instruction exception handling 112
 Sleep mode..... 934, 958
 Slot illegal instructions 113
 Smart card interface 710
 Software protection..... 868
 Software standby mode..... 934, 960
 Space state 686
 Stack status after exception handling 114
 Standard serial communication interface
 specifications for boot mode 874
 Start bit..... 686
 State transition of TAP controller 918
 State transitions..... 68
 Stop bit..... 686
 Strobe assert/negate timing 209
 Synchronous clearing..... 520
 Synchronous operation..... 520
 Synchronous presetting..... 520
 System clock (I ϕ)..... 197, 923

T	
TAP controller	918
Toggle output.....	517
Trace exception handling.....	107
Transfer information	363
Transfer information read skip function.....	372
Transfer information writeback skip function.....	373
Transfer modes	305
Transmit/receive data.....	686
Trap instruction exception handling	111
U	
User boot MAT.....	816
User boot mode.....	814, 857
User break controller (UBC)	159
User MAT.....	816
User program mode.....	814, 847
V	
Vector table address	102
Vector table address offset.....	102
W	
Wait control	225
Watchdog timer (WDT).....	629
Watchdog timer mode.....	634
Waveform output by compare match.....	516
Write data buffer function.....	268
Write data buffer function for external data bus	268
Write data buffer function for peripheral modules	269

**Renesas 32-Bit CISC Microcomputer
Hardware Manual
H8SX/1638 Group, H8SX/1638L Group**

Publication Date: Rev.1.00, Sep. 13, 2007
Rev.2.00, Sep. 10, 2008
Published by: Sales Strategic Planning Div.
Renesas Technology Corp.
Edited by: Customer Support Department
Global Strategic Communication Div.
Renesas Solutions Corp.

Renesas Technology Corp. Sales Strategic Planning Div. Nippon Bldg., 2-6-2, Ohte-machi, Chiyoda-ku, Tokyo 100-0004, Japan



RENESAS SALES OFFICES

<http://www.renesas.com>

Refer to "<http://www.renesas.com/en/network>" for the latest and detailed information.

Renesas Technology America, Inc.

450 Holger Way, San Jose, CA 95134-1368, U.S.A
Tel: <1> (408) 382-7500, Fax: <1> (408) 382-7501

Renesas Technology Europe Limited

Dukes Meadow, Millboard Road, Bourne End, Buckinghamshire, SL8 5FH, U.K.
Tel: <44> (1628) 585-100, Fax: <44> (1628) 585-900

Renesas Technology (Shanghai) Co., Ltd.

Unit 204, 205, AZIA Center, No.1233 Lujiazui Ring Rd, Pudong District, Shanghai, China 200120
Tel: <86> (21) 5877-1818, Fax: <86> (21) 6887-7858/7898

Renesas Technology Hong Kong Ltd.

7th Floor, North Tower, World Finance Centre, Harbour City, Canton Road, Tsimshatsui, Kowloon, Hong Kong
Tel: <852> 2265-6688, Fax: <852> 2377-3473

Renesas Technology Taiwan Co., Ltd.

10th Floor, No.99, Fushing North Road, Taipei, Taiwan
Tel: <886> (2) 2715-2888, Fax: <886> (2) 3518-3399

Renesas Technology Singapore Pte. Ltd.

1 Harbour Front Avenue, #06-10, Keppel Bay Tower, Singapore 098632
Tel: <65> 6213-0200, Fax: <65> 6278-8001

Renesas Technology Korea Co., Ltd.

Kukje Center Bldg. 18th Fl., 191, 2-ka, Hangang-ro, Yongsan-ku, Seoul 140-702, Korea
Tel: <82> (2) 796-3115, Fax: <82> (2) 796-2145

Renesas Technology Malaysia Sdn. Bhd

Unit 906, Block B, Menara Amcorp, Amcorp Trade Centre, No.18, Jln Persiaran Barat, 46050 Petaling Jaya, Selangor Darul Ehsan, Malaysia
Tel: <603> 7955-9390, Fax: <603> 7955-9510



H8SX/1638 Group, H8SX/1638L Group Hardware Manual

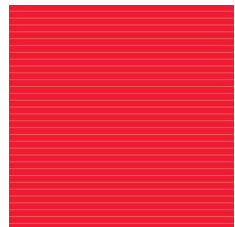

Renesas Technology Corp.

2-6-2, Ote-machi, Chiyoda-ku, Tokyo, 100-0004, Japan