



FDMF6704A - XS™ DrMOS

The Xtra Small High Performance, High Frequency DrMOS Module

Benefits

- Ultra compact size - 6 mm x 6 mm MLP, 44 % space saving compared to conventional MLP 8 mm x 8 mm DrMOS packages.
- Fully optimized system efficiency.
- Clean voltage waveforms with reduced ringing.
- High frequency operation.

Features

- Ultra- compact thermally enhanced 6 mm x 6 mm MLP package 84 % smaller than conventional discrete solutions.
- Synchronous driver plus FET multichip module.
- High current handling of 35 A.
- Over 93 % peak efficiency.
- Logic level PWM input.
- Fairchild's PowerTrench® 5 technology MOSFETs for clean voltage waveforms and reduced ringing.
- Optimized for high switching frequencies of up to 1 MHz.
- Skip mode SMOD [low side gate turn off] input.
- Fairchild SyncFET™ [integrated Schottky diode] technology in the low side MOSFET.
- Integrated bootstrap Schottky diode.
- Adaptive gate drive timing for shoot-through protection.
- Driver output disable function [DISB# pin].
- Undervoltage lockout (UVLO).
- Fairchild Green Packaging and RoHS compliant. Low profile SMD package.



General Description

The XS™ DrMOS family is Fairchild's next-generation fully-optimized ultra-compact integrated MOSFET plus driver power stage solution for high current, high frequency synchronous buck DC-DC applications. The FDMF6704A DrMOS integrates a driver IC, two power MOSFETs and a bootstrap Schottky diode into a thermally enhanced compact 6 mm x 6 mm MLP package. With an integrated approach, the complete switching power stage is optimized with regards to driver and MOSFET dynamic performance, system inductance and $R_{DS(ON)}$. This greatly reduces the package parasitics and layout challenges associated with conventional discrete solutions. The driver IC incorporates advanced features such as SMOD. A 5 V gate drive and an improved PCB interface [Low Side MOSFET exposed pad] ensure higher performance. This product meets the Intel 6 mm x 6 mm DrMOS pinout.

Applications

- Compact blade servers V-core, non V-core and VTT DC-DC converters.
- Desktop computers V-core, non V-core and VTT DC-DC converters.
- Workstations V-core, non V-core and VTT DC-DC converters.
- Gaming Motherboards V-core, non V-core and VTT DC-DC converters.
- Gaming consoles.
- High-current DC-DC Point of Load (POL) converters.
- Networking and telecom microprocessor voltage regulators.
- Small form factor voltage regulator modules.

Power Train Application Circuit

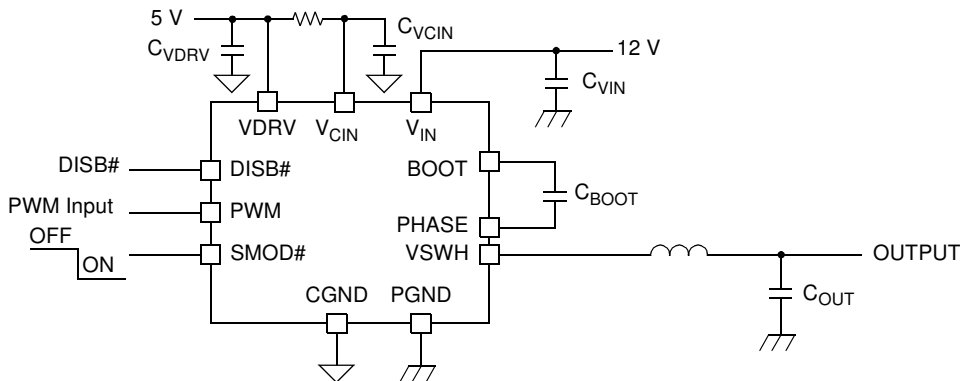

Figure 1. Power Train Application Circuit

Ordering Information

Part	Current Rating @ 350 kHz [A]	Input Voltage Typical [V]	Frequency Max [kHz]	Device Marking
FDMF6704A	35	8-14	1000	FDMF6704A

Functional Block Diagram

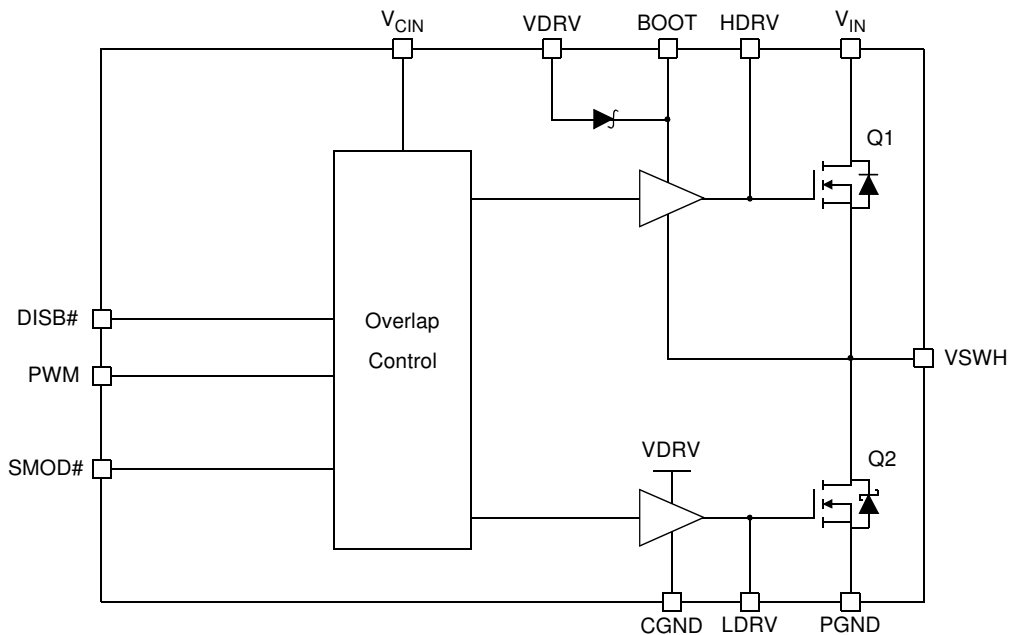

Figure 2. Functional Block Diagram

Pin Configuration

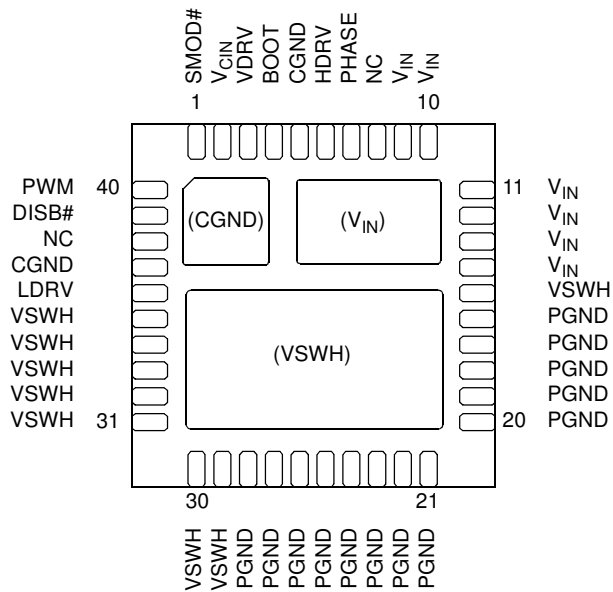

Figure 3. 6mm x 6mm, 40L MLP Bottom View

Pin Description

Pin	Name	Function
1	SMOD#	When SMOD# = HI, low side driver is inverse of PWM input. When SMOD# = Low, low side driver is disabled.
2	V _{CIN}	IC bias supply. Minimum 1 μ F ceramic capacitor is recommended from this pin to CGND.
3	VDRV	Power for low side driver. Minimum 1 μ F ceramic capacitor is recommended to be connected as close as possible from this pin to CGND.
4	BOOT	Bootstrap supply input. Provides voltage supply to high-side MOSFET driver. Connect bootstrap capacitor from this pin to PHASE.
5, 37	CGND	IC ground. Ground return for driver IC.
6	HDRV	For manufacturing test only. This pin must be floated. Must not be connected to any pin.
7	PHASE	Switch node pin for easy bootstrap capacitor routing. Electrically shorted to VSWH pin.
8, 38	NC	No connect.
9-14	V _{IN}	Power input. Output stage supply voltage.
15, 29-35	VSWH	Switch node input. Provides return for high-side bootstrapped driver and acts as a sense point for the adaptive shoot-thru protection.
16-28	PGND	Power ground. Output stage ground. Source pin of low side MOSFET(s).
36	LDRV	For manufacturing test only. This pin must be floated. Must not be connected to any pin.
39	DISB#	Output Disable. When low, this pin disable FET switching (HDRV and LDRV are held low).
40	PWM	PWM Signal Input. This pin accepts a logic-level PWM signal from the controller.

Absolute Maximum Rating

Parameter	Min	Max	Units	
V _{CIN} , VDRV, DISB#, PWM, SMOD#, LDRV to CGND		6	V	
V _{IN} to PGND, CGND		27	V	
BOOT, HDRV to VSWH		6	V	
BOOT, VSWH, HDRV to GND		27	V	
BOOT to VDRV		22	V	
I _{O(AV)}	V _{IN} = 12 V, V _O = 1.3 V	f _{SW} = 350 kHz	35	A
		f _{SW} = 1 MHz	32	A
I _{O(peak)}		80	A	
R _{θJPCB}	Junction to PCB Thermal Resistance	3.75	°C/W	
Operating and Storage Junction Temperature Range		-55	150	°C

Recommended Operating Range

Parameter	Min	Typ	Max	Units	
V _{CIN}	Control Circuit Supply Voltage	4.5	5	5.5	V
V _{IN}	Output Stage Supply Voltage	8*	12	14	V

* May be operated at lower input voltage. See figure 8.

Electrical Characteristics

$V_{IN} = 12\text{ V}$, $T_A = 25\text{ }^\circ\text{C}$ unless otherwise noted.

Parameter	Symbol	Conditions	Min	Typ	Max	Units
Operating Quiescent Current	IQ	PWM = GND			2	mA
		PWM = V_{CIN}			2	
VCIN UVLO						
UVLO Threshold			3.0	3.2	3.4	V
UVLO COMP Hysteresis				0.2		V
PWM, DISB# and SMOD# Input						
High Level Input Voltage			2			V
Low Level Input Voltage					0.8	V
Input Bias Current			-2		2	μA
Propagation Delay Time		PWM = GND, delay between SMOD# or DISB# from HI to LO to LDRV from HI to LO.		15		ns
High Side Driver						
Rise Time		10 % to 90 %		25		ns
Fall Time		90 % to 10 %		20		ns
Deadband Time	t_{DTHH}	LDRV going LO to HDRV going HI, 10 % to 10 %		25		ns
Propagation Delay	t_{PDHL}	PMW going LO to HDRV going LO		10		ns
Low Side Driver						
Rise Time		10 % to 90 %		25		ns
Fall Time		90 % to 10 %		20		ns
Deadband Time	t_{DTLH}	VSWH going LO to LDRV going HI, 10 % to 10 %		20		ns
Propagation Delay	t_{PDLL}	PWM going HI to LDRV going LO		10		ns
250 ns Time Out Circuit						
250 ns Time Delay		Delay between HDRV from HI to LO and LDRV from LO to HI.		250		ns

Description of Operation

Circuit Description

The FDMF6704A is a driver plus FET module optimized for synchronous buck converter topology. A single PWM input signal is all that is required to properly drive the high-side and the low-side MOSFETs. Each part is capable of driving speeds up to 1 MHz.

Low-Side Driver

The low-side driver (LDRV) is designed to drive a ground referenced low $R_{DS(ON)}$ N-channel MOSFET. The bias for LDRV is internally connected between VDRV and CGND. When the driver is enabled, the driver's output is 180° out of phase with the PWM input. When the driver is disabled (DISB = 0 V), LDRV is held low.

High-Side Driver

The high-side driver (HDRV) is designed to drive a floating N-channel MOSFET. The bias voltage for the high-side driver is developed by a bootstrap supply circuit, consisting of the internal diode and external bootstrap capacitor (C_{BOOT}). During start-up, VSWH is held at PGND, allowing C_{BOOT} to charge to VDRV through the internal diode. When the PWM input goes high, HDRV will begin to charge the high-side MOSFET's gate (Q1). During this transition, charge is removed from C_{BOOT} and delivered to Q1's gate. As Q1 turns on, VSWH rises to V_{IN} , forcing the BOOT pin to $V_{IN} + V_{C(BOOT)}$, which provides sufficient VGS enhancement for Q1. To complete the switching cycle, Q1 is turned off by pulling HDRV to VSWH. C_{BOOT} is then recharged to VDRV when VSWH falls to PGND. HDRV output is in phase with the PWM input. When the driver is disabled, the high-side gate is held low.

SMOD

The SMOD (Skip Mode) function allows for higher converter efficiency under light load conditions. During SMOD, the LS FET is disabled and it prevents discharging of output caps. When the SMOD# pin is pulled high, the sync buck converter

will work in synchronous mode. When the SMOD# pin is pulled low, the LS FET is turned off. The SMOD function does not have internal current sensing. This SMOD# pin is connected to a PWM controller which enables or disables the SMOD automatically when the controller detects light load condition. Normally this pin is Active Low.

Adaptive Gate Drive Circuit

The driver IC embodies an advanced design that ensures minimum MOSFET dead-time while eliminating potential shoot-through (cross-conduction) currents. It senses the state of the MOSFETs and adjusts the gate drive, adaptively, to ensure they do not conduct simultaneously. Refer to Figure 4 for the relevant timing waveforms.

To prevent overlap during the low-to-high switching transition (Q2 OFF to Q1 ON), the adaptive circuitry monitors the voltage at the LDRV pin. When the PWM signal goes HIGH, Q2 will begin to turn OFF after some propagation delay (t_{PDLL}). Once the LDRV pin is discharged below 1 V, Q1 begins to turn ON after adaptive delay t_{DTHH} .

To preclude overlap during the high-to-low transition (Q1 OFF to Q2 ON), the adaptive circuitry monitors the voltage at the VSWH pin. When the PWM signal goes LOW, Q1 will begin to turn OFF after some propagation delay (t_{PDHL}). Once the VSWH pin falls below 1 V, Q2 begins to turn ON after adaptive delay t_{DTLH} .

Additionally, V_{GS} of Q1 is monitored. When $V_{GS(Q1)}$ is discharged low, a secondary adaptive delay is initiated, which results in Q2 being driven ON after 250 ns, regardless of VSWH state. This function is implemented to ensure C_{BOOT} is recharged each switching cycle, particularly for cases where the power converter is sinking current and VSWH voltage does not fall below the 1 V adaptive threshold. The 250 ns secondary delay is longer than t_{DTLH} .

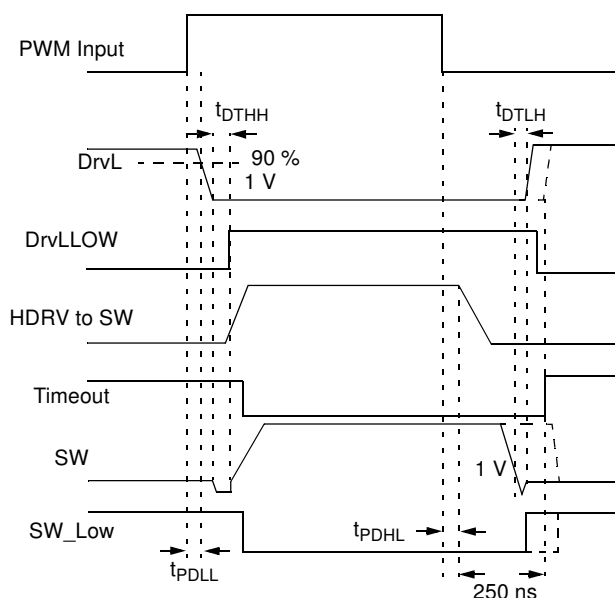

Figure 4. Adaptive Gate Drive Timing

Typical Characteristics

$V_{IN} = 12V$, $V_{CIN} = 5V$, $T_A = 25^\circ C$ unless otherwise noted.

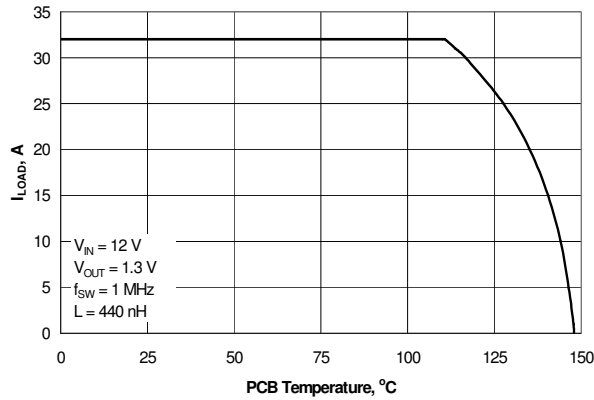

Figure 5. Safe Operating Area

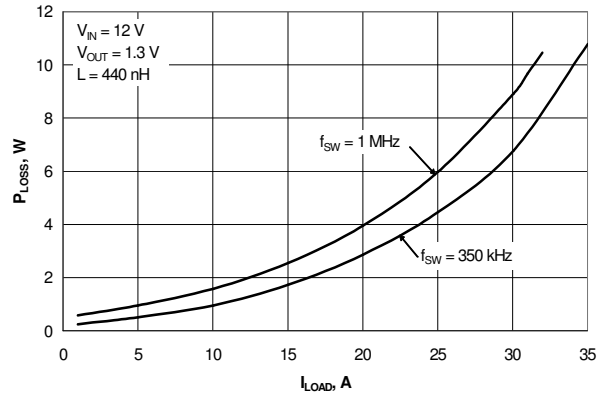

Figure 6. Module Power Loss vs. Output Current

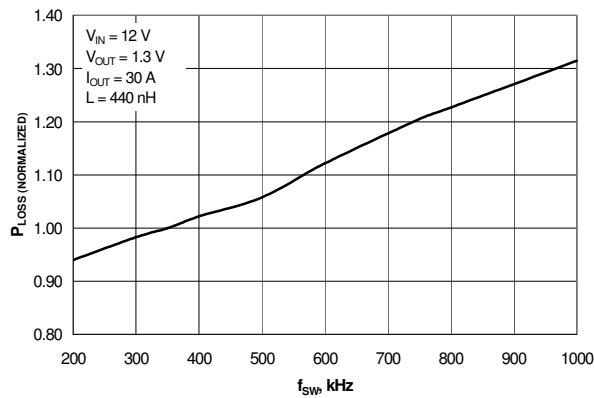

Figure 7. Power Loss vs. Switching Frequency

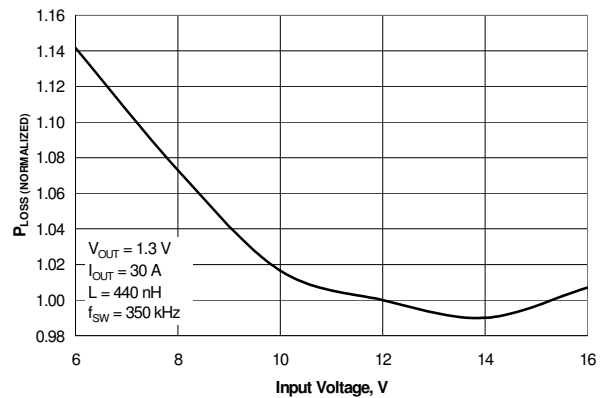

Figure 8. Power Loss vs. Input Voltage

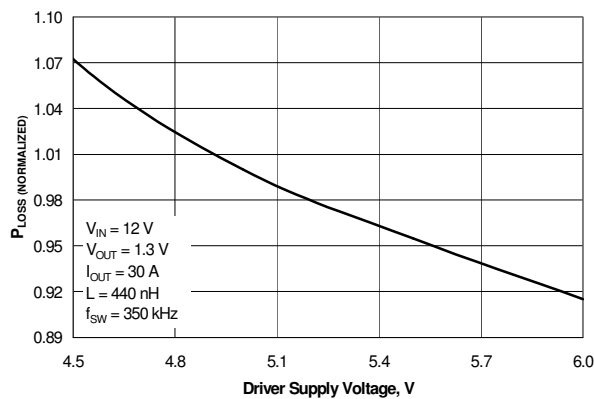

Figure 9. Power Loss vs. Driver Supply Voltage

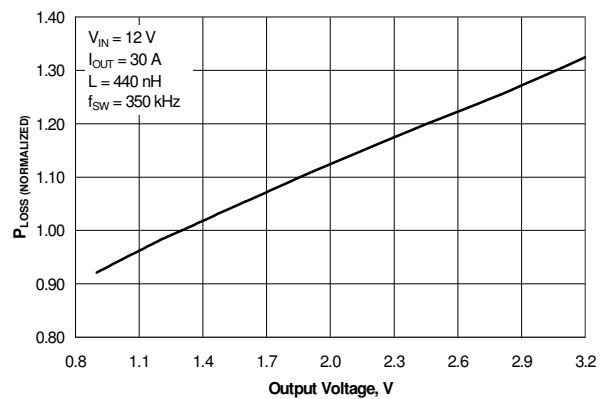

Figure 10. Power Loss vs. Output Voltage

Typical Characteristics

$V_{IN} = 12V$, $V_{CIN} = 5V$, $T_A = 25^\circ C$ unless otherwise noted.

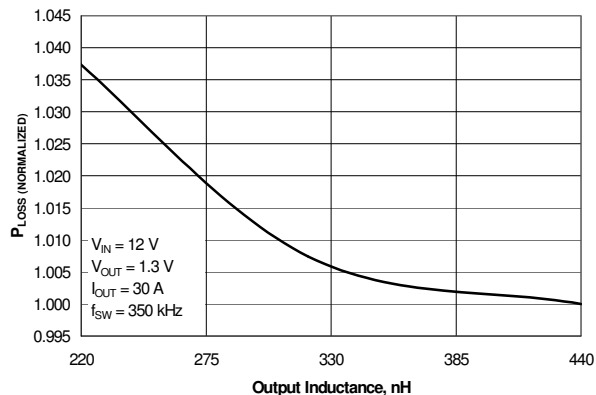

Figure 11. Power Loss vs. Output Inductance

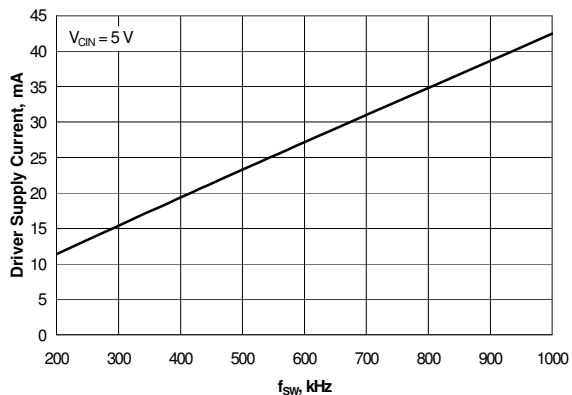

Figure 12. Driver Supply Current vs. Frequency

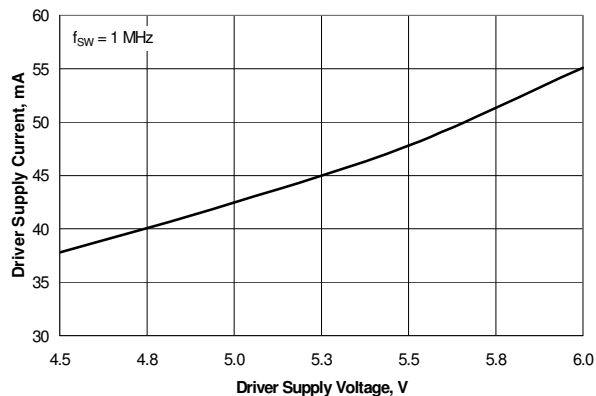

Figure 13. Driver Supply Current vs. Drive Supply Voltage

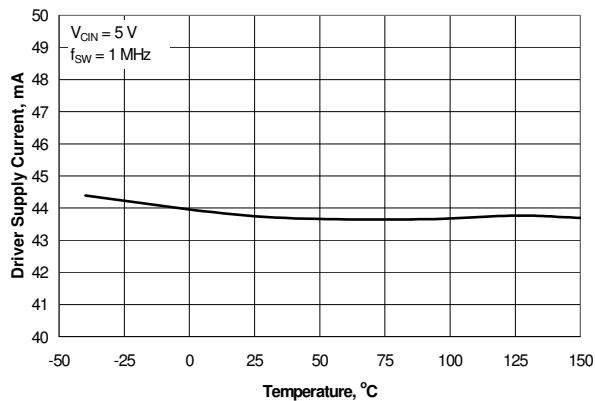

Figure 14. Driver Supply Current vs. Temperature

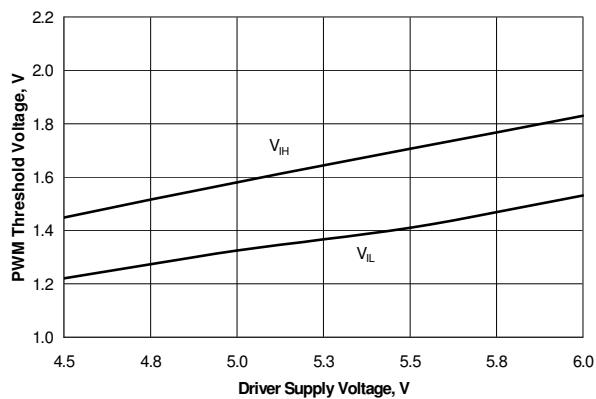

Figure 15. PWM Threshold Voltage vs. Driver Supply Voltage

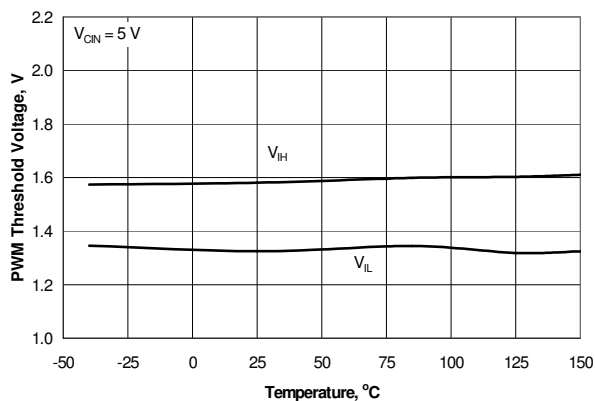

Figure 16. PWM Threshold Voltage vs. Temperature

Typical Characteristics

$V_{IN} = 12V$, $V_{CIN} = 5V$, $T_A = 25^\circ C$ unless otherwise noted.

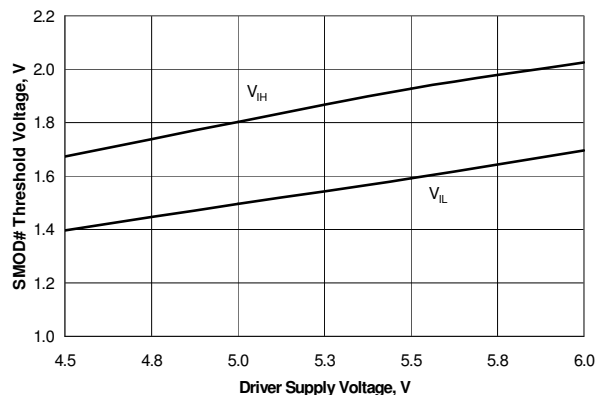

Figure 17. SMOD# Threshold Voltage vs. Driver Supply Voltage

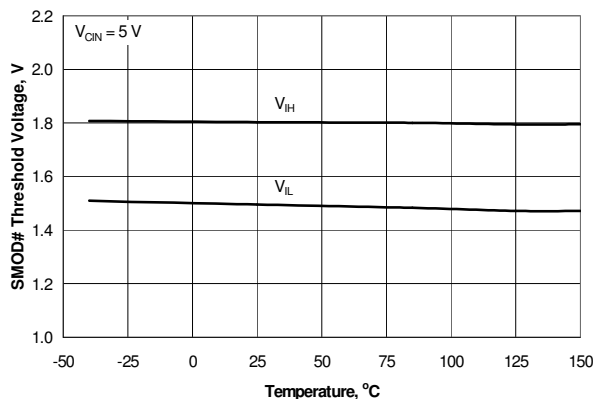

Figure 18. SMOD# Threshold Voltage vs. Temperature

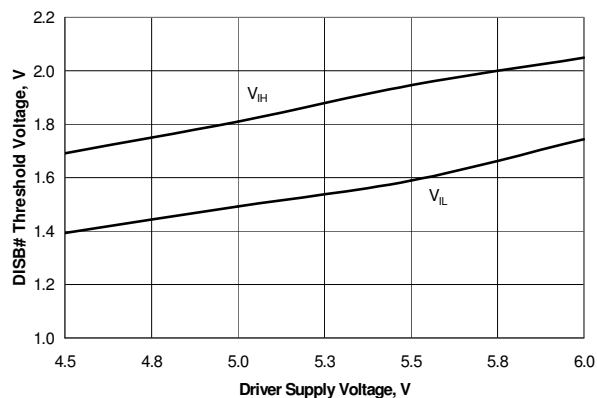

Figure 19. DISB# Threshold Voltage vs. Driver Supply Voltage

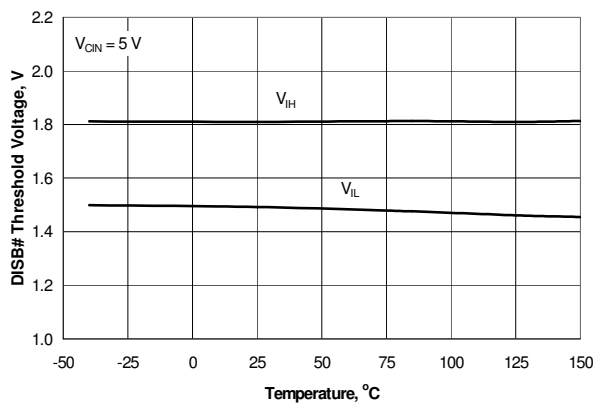

Figure 20. DISB# Threshold Voltage vs. Temperature

Application Information

Supply Capacitor Selection

For the supply input (V_{CIN}) of the FDMF6704A, a local ceramic bypass capacitor is recommended to reduce the noise and to supply the peak current. Use at least a $1\mu\text{F}$, X7R or X5R capacitor. Keep this capacitor close to the FDMF6704A V_{CIN} and PGND pins.

Bootstrap Circuit

The bootstrap circuit uses a charge storage capacitor (C_{BOOT}), as shown in Figure 21. A bootstrap capacitance of 100nF , X7R or X5R capacitor is adequate.

V_{CIN} Filter

The VDRV pin provides power to the gate drive of the high side and low side power FET. In most cases, it can be connected directly to V_{CIN} , the pin that provides power to the logic section of the driver. For additional noise immunity, an RC filter can be inserted between VDRV and V_{CIN} . Recommended values would be 10 Ohms and $1\mu\text{F}$.

Typical Application

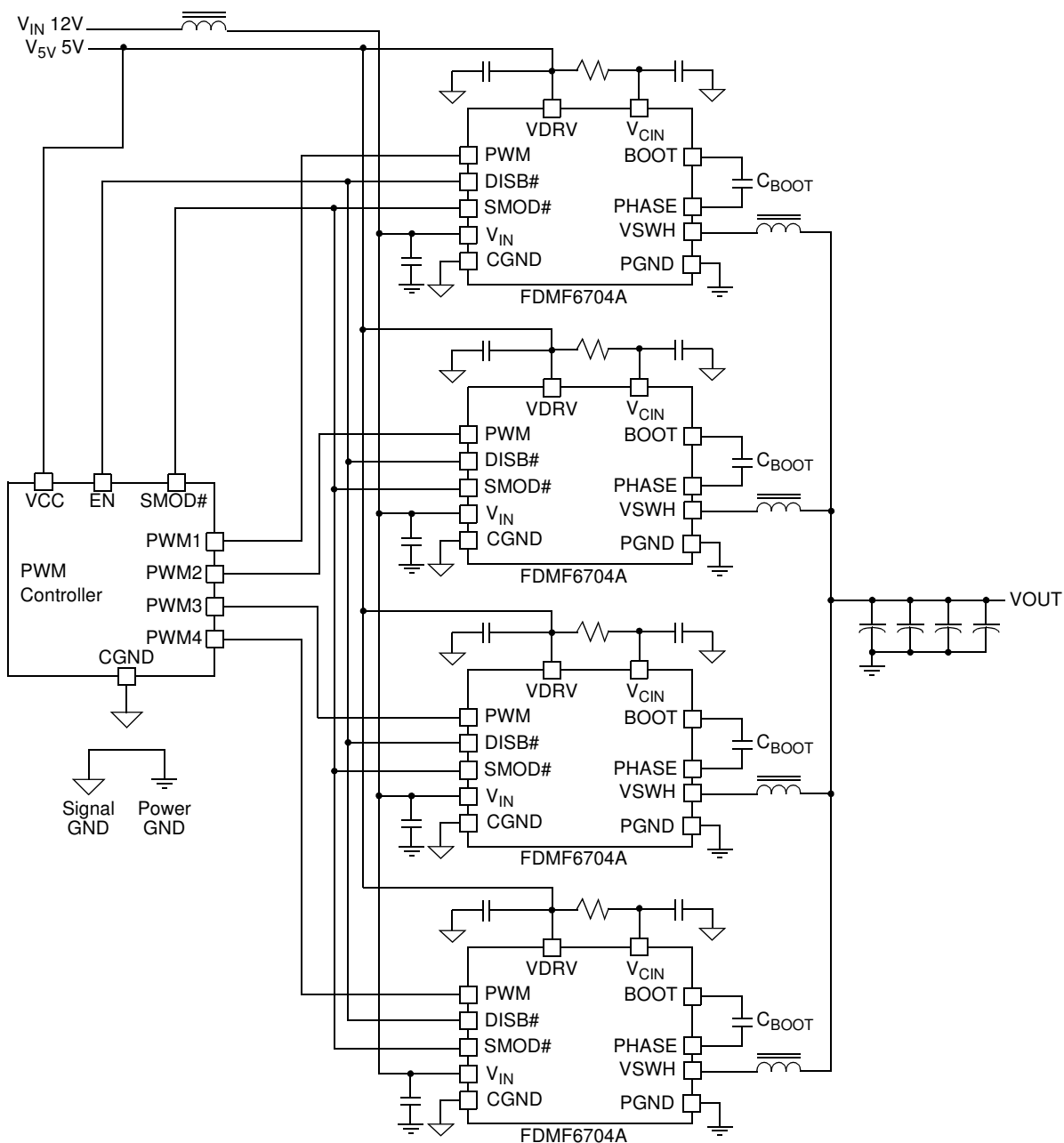

Figure 21. Typical Application

Module Power Loss and Efficiency Measurement and Calculation

Refer to Figure 22 for module power loss testing method. Power loss calculation are as follows:

- (a) $P_{IN} = (V_{IN} \times I_{IN}) + (V_{5V} \times I_{5V})$ (W)
- (b) $P_{OUT} = V_O \times I_{OUT}$ (W)
- (c) $P_{LOSS} = P_{IN} - P_{OUT}$ (W)
- (d) Efficiency = $100 \times P_{OUT}/P_{IN}$ (%)

PCB Layout Guideline

Figure 23 shows a proper layout example of FDMF6704A and critical parts. All of high current flow path, such as V_{IN} , VSWH, V_{OUT} and GND copper, should be short and wide for better and stable current flow, heat radiation and system performance.

Following is a guideline which the PCB designer should consider:

1. Input bypass capacitors should be close to V_{IN} and PGND pin of FDMF6704A to help reduce input current ripple component induced by switching operation.
2. It is critical that the VSWH copper has minimum area for lower switching noise emission. VSWH copper trace should

also be wide enough for high current flow. Other signal routing path, such as PWM IN and BOOT signal, should be considered with care to avoid noise pickup from VSWH copper area.

3. Output inductor location should be as close as possible to the FDMF6704A for lower power loss due to copper trace.

4. The PowerTrench® 5 MOSFETs used in the output stage are very effective at minimizing ringing. In most cases, no snubber will be required. If a snubber is used, it should be placed near the FDMF6704A. The resistor and capacitor need to be of proper size for power dissipation.

5. Place ceramic bypass capacitor and boot capacitor as close to V_{CIN} and BOOT pin of FDMF6704A in order to supply stable power. Routing width and length should also be considered.

6. Ringing at the Boot pin is most effectively controlled by close placement of the capacitor. Do not add an additional Boot to PGND capacitor. This may lead to excess current flow through the Boot diode.

7. Use multiple Vias on each copper area to interconnect each top, inner and bottom layer to help smooth current flow and heat conduction. Vias should be relatively large and of reasonable inductance.

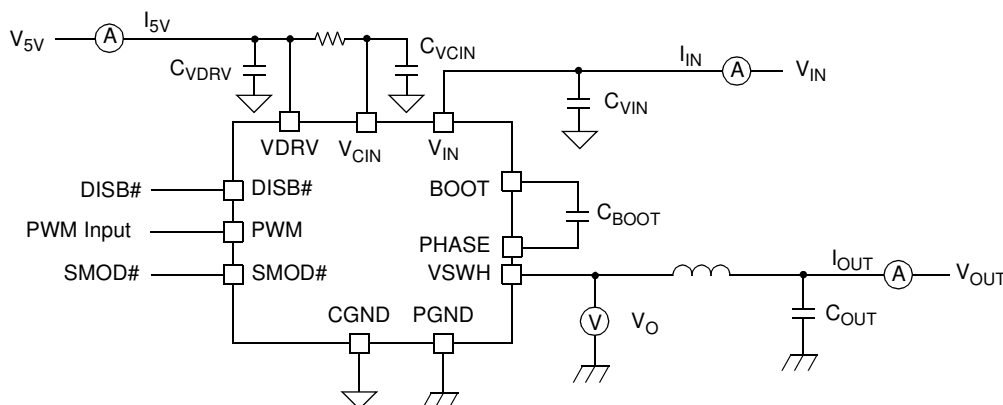

Figure 22. Power Loss Measurement Block Diagram

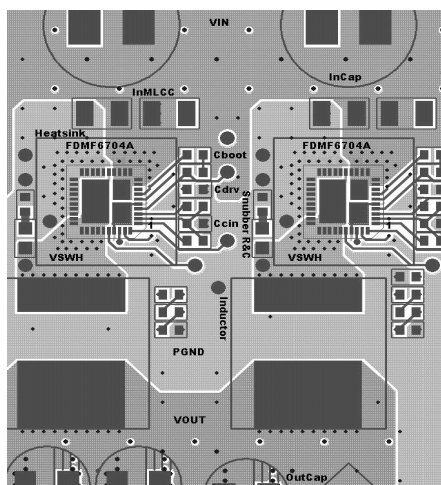
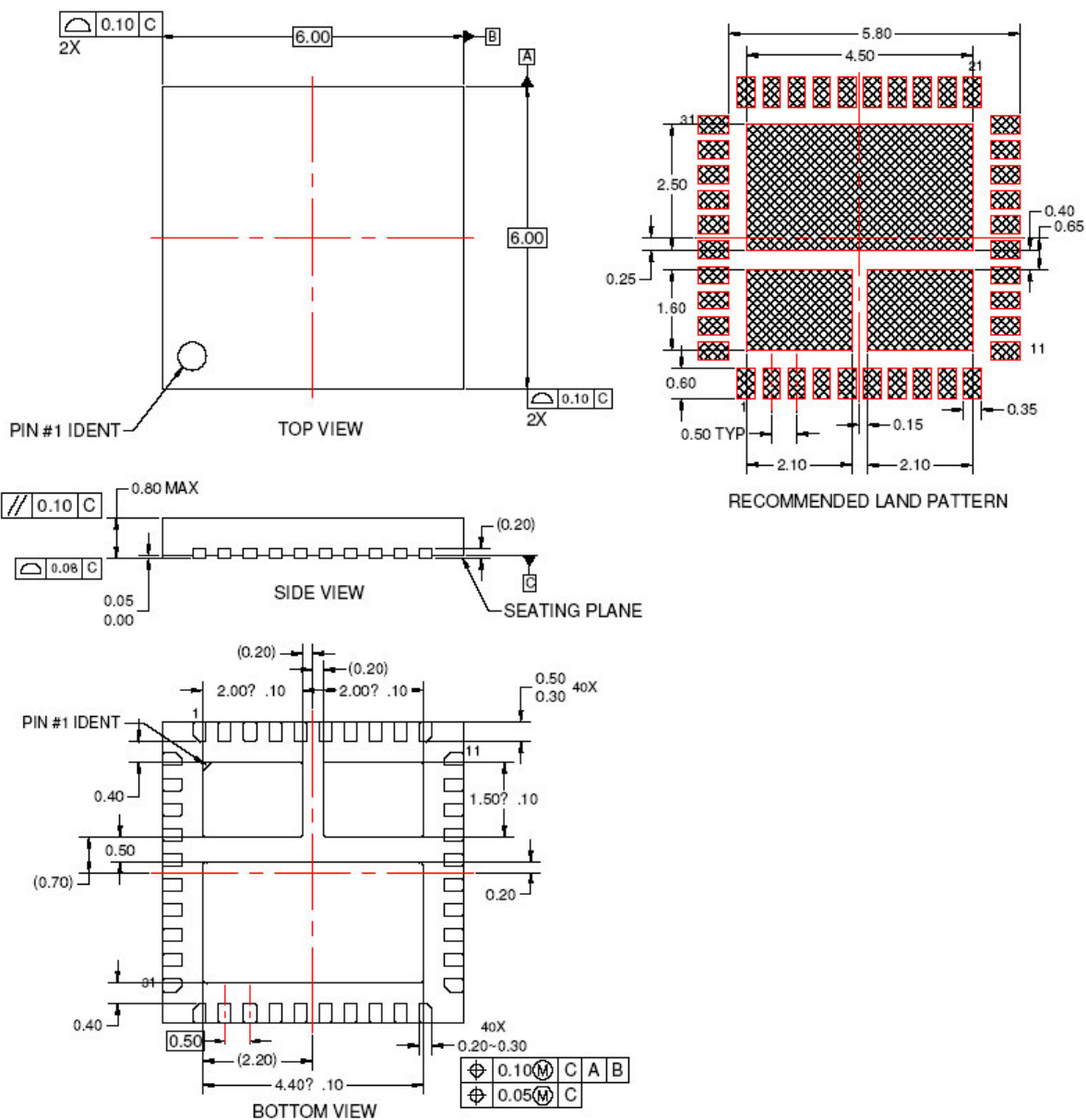

Figure 23. Typical PCB Layout Example (Top View)

Dimensional Outline and Pad layout



NOTES:







- A. DOES NOT FULLY CONFORM TO JEDEC REGISTRATION, MO-220. DATED MAY/2005.
- B. DIMENSIONS ARE IN MILLIMETERS.
- C. DIMENSIONS AND TOLERANCES PER ASME Y14.5M, 1994
- D. DRAWING FILE NAME: MLP40CREV1

MLP40Crev1



TRADEMARKS

The following includes registered and unregistered trademarks and service marks, owned by Fairchild Semiconductor and/or its global subsidiaries, and is not intended to be an exhaustive list of all such trademarks.

- | | | | |
|---|---|---|---|
| Build it Now™ | F-PFS™ | PowerTrench® | The Power Franchise® |
| CorePLUS™ | FRFET® | Programmable Active Droop™ | the power franchise |
| CorePOWER™ | Global Power Resource™ | QFET® | TinyBoost™ |
| CROSSVOLT™ | Green FPS™ | QS™ | TinyBuck™ |
| CTL™ | Green FPS™ e-Series™ | Quiet Series™ | TinyLogic® |
| Current Transfer Logic™ | GTO™ | RapidConfigure™ | TINYOPTO™ |
| EcoSPARK® | IntelliMAX™ |  ™ | TinyPower™ |
| EfficientMax™ | ISOPLANAR™ | Saving our world, 1mW/W/kW at a time™ | TinyPWM™ |
| EZSWITCH™ * | MegaBuck™ | SmartMax™ | TinyWire™ |
|  ™ | MICROCOUPLER™ | SMART START™ | µSerDes™ |
|  ® | MicroFET™ | SPM® |  |
| Fairchild® | MicroPak™ | STEALTH™ | UHC® |
| Fairchild Semiconductor® | MillerDrive™ | SuperFET™ | Ultra FRFET™ |
| FACT Quiet Series™ | MotionMax™ | SuperSOT™-3 | UniFET™ |
| FACT® | Motion-SPM™ | SuperSOT™-6 | VCX™ |
| FAST® | OPTOLOGIC® | SuperSOT™-8 | VisualMax™ |
| FastvCore™ | OPTOPLANAR® | SupreMOS™ | |
| FlashWriter® * |  ™ | SyncFET™ | |
| FPS™ | PDP µPM™ |  | |
| | Power-SPM™ | | |

* EZSWITCH™ and FlashWriter® are trademarks of System General Corporation, used under license by Fairchild Semiconductor.

DISCLAIMER

FAIRCHILD SEMICONDUCTOR RESERVES THE RIGHT TO MAKE CHANGES WITHOUT FURTHER NOTICE TO ANY PRODUCTS HEREIN TO IMPROVE RELIABILITY, FUNCTION, OR DESIGN. FAIRCHILD DOES NOT ASSUME ANY LIABILITY ARISING OUT OF THE APPLICATION OR USE OF ANY PRODUCT OR CIRCUIT DESCRIBED HEREIN; NEITHER DOES IT CONVEY ANY LICENSE UNDER ITS PATENT RIGHTS, NOR THE RIGHTS OF OTHERS. THESE SPECIFICATIONS DO NOT EXPAND THE TERMS OF FAIRCHILD'S WORLDWIDE TERMS AND CONDITIONS, SPECIFICALLY THE WARRANTY THEREIN, WHICH COVERS THESE PRODUCTS.

LIFE SUPPORT POLICY

FAIRCHILD'S PRODUCTS ARE NOT AUTHORIZED FOR USE AS CRITICAL COMPONENTS IN LIFE SUPPORT DEVICES OR SYSTEMS WITHOUT THE EXPRESS WRITTEN APPROVAL OF FAIRCHILD SEMICONDUCTOR CORPORATION.

As used herein:

1. Life support devices or systems are devices or systems which, (a) are intended for surgical implant into the body or (b) support or sustain life, and (c) whose failure to perform when properly used in accordance with instructions for use provided in the labeling, can be reasonably expected to result in a significant injury of the user.
2. A critical component in any component of a life support, device, or system whose failure to perform can be reasonably expected to cause the failure of the life support device or system, or to affect its safety or effectiveness.

ANTI-COUNTERFEITING POLICY

Fairchild Semiconductor Corporation's Anti-Counterfeiting Policy. Fairchild's Anti-Counterfeiting Policy is also stated on our external website, www.fairchildsemi.com, under Sales Support.

Counterfeiting of semiconductor parts is a growing problem in the industry. All manufacturers of semiconductor products are experiencing counterfeiting of their parts. Customers who inadvertently purchase counterfeit parts experience many problems such as loss of brand reputation, substandard performance, failed applications, and increased cost of production and manufacturing delays. Fairchild is taking strong measures to protect ourselves and our customers from the proliferation of counterfeit parts. Fairchild strongly encourages customers to purchase Fairchild parts either directly from Fairchild or from Authorized Fairchild Distributors who are listed by country on our web page cited above. Products customers buy either from Fairchild directly or from Authorized Fairchild Distributors are genuine parts, have full traceability, meet Fairchild's quality standards for handling and storage and provide access to Fairchild's full range of up-to-date technical and product information. Fairchild and our Authorized Distributors will stand behind all warranties and will appropriately address any warranty issues that may arise. Fairchild will not provide any warranty coverage or other assistance for parts bought from Unauthorized Sources. Fairchild is committed to combat this global problem and encourage our customers to do their part in stopping this practice by buying direct or from authorized distributors.

PRODUCT STATUS DEFINITIONS

Definition of Terms

Datasheet Identification	Product Status	Definition
Advance Information	Formative / In Design	Datasheet contains the design specifications for product development. Specifications may change in any manner without notice.
Preliminary	First Production	Datasheet contains preliminary data; supplementary data will be published at a later date. Fairchild Semiconductor reserves the right to make changes at any time without notice to improve design.
No Identification Needed	Full Production	Datasheet contains final specifications. Fairchild Semiconductor reserves the right to make changes at any time without notice to improve the design.
Obsolete	Not In Production	Datasheet contains specifications on a product that is discontinued by Fairchild Semiconductor. The datasheet is for reference information only.

Rev. I36