

# SKY65105: 1700 – 2200 MHz Linear Power Amplifier

## Applications

- PCS/DCS/UMTS
- Repeaters
- WLL and ISM bands
- Mobile radio
- Telematics

## Features

- Typical  $P_{OUT}$  of 30 dBm
- High linearity
- Low power consumption
- Single +5 V supply
- MCM (12-pin, 8 x 8 mm) Pb-free (MSL3, 260 °C per JEDEC J-STD-020) package

**NEW**

Skyworks offers lead (Pb)-free, RoHS (Restriction of Hazardous Substances) compliant packaging.



## Description

Skyworks SKY65105 Power Amplifier (PA) is a fully matched, 12-pin Multi-Chip Module (MCM) surface mount module, developed for Personal Communications System (PCS), Digital Communications System (DCS), and Universal Mobile Telephone System (UMTS) applications. Wireless Local Loop (WLL) and Industrial, Scientific, Medical (ISM) applications are also supported.

This small, power-efficient PA has a full 1700 to 2200 MHz bandwidth coverage packed into a single compact package. All active circuitry in the module is contained in a single Gallium Arsenide (GaAs) Microwave Monolithic Integrated Circuit (MMIC). The SKY65105 is manufactured with Skyworks Aluminum (Al) GaAs Heterojunction Bipolar Transistor (HBT) process, which allows for single supply operation while maintaining high efficiency and good linearity.

Figure 1 shows a functional block diagram for the SKY65105. The SKY65105 is packaged in a small, 12-pin 8 x 8 mm Multi-Chip Module (MCM) package. The pin configuration and package are shown in Figure 2. Signal pin assignments and functional pin descriptions are provided in Table 1.

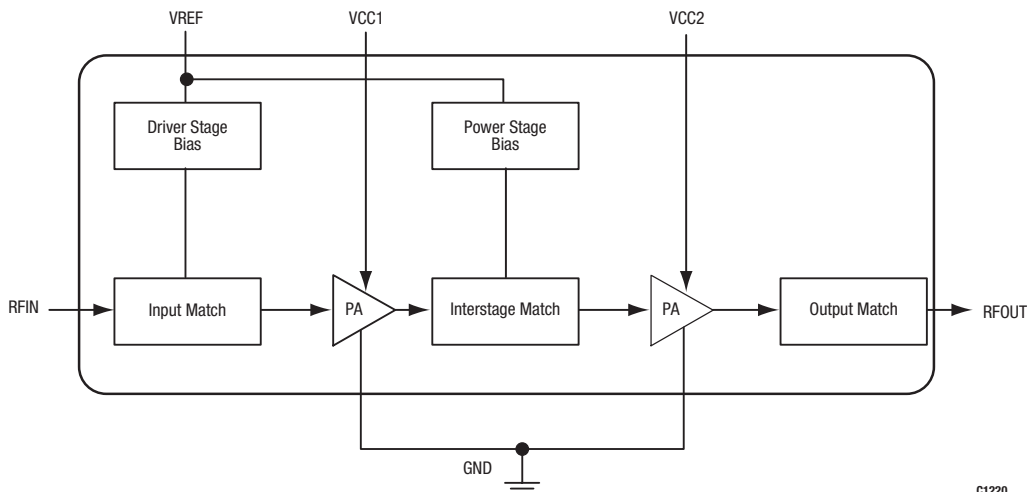

**Figure 1. SKY65105 Functional Block Diagram**

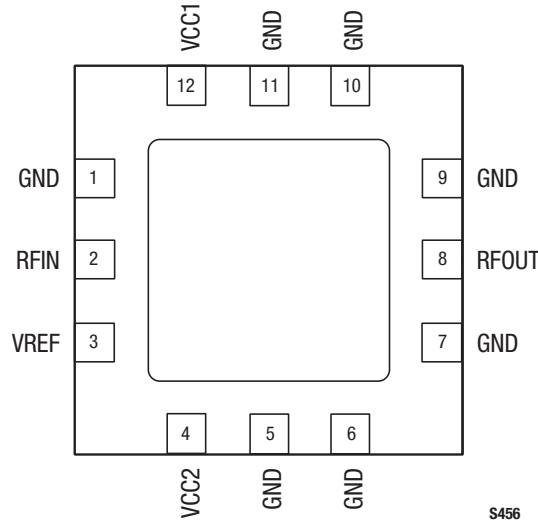

**Figure 2. SKY65105 Pinout– 12-Pin MCM Package (Top View)**

**Table 1. SKY65105 Signal Descriptions**

Pin #	Name	Description	Pin #	Name	Description
1	GND	Ground	7	GND	Ground
2	RFIN	RF input	8	RFOUT	RF output
3	VREF	Reference voltage	9	GND	Ground
4	VCC2	Supply voltage	10	GND	Ground
5	GND	Ground	11	GND	Ground
6	GND	Ground	12	VCC1	Supply voltage

**Technical Description**

The SKY65105 is comprised of two amplifier stages. The matching circuits for the input stage, inter-stage, and output stage are contained within the device. The bias circuits for both input and output stages are included within the device for optimum temperature tracking performance.

The SKY65105 is internally matched for optimum linearity and efficiency. The input and output stages are independently supplied using the VCC1 and VCC2 supply lines, pins 12 and 4 respectively. The bias reference voltage is supplied using a common VREF (pin 3) line.

**Electrical and Mechanical Specifications**

The absolute maximum ratings of the SKY65105 are provided in Table 2. The recommended operating conditions are specified in Table 3 and electrical specifications are provided in Table 4.

Typical performance characteristics over temperature of the SKY65105 are illustrated in Figures 3 through 10.

**Table 2. SKY65105 Absolute Maximum Ratings**

Parameter	Symbol	Min	Typical	Max	Units
RF output power	P <sub>OUT</sub>			31	dBm
Supply voltage (VCC1 and VCC2)	V <sub>CC</sub>			6	V
Reference voltage	V <sub>REF</sub>			4	V
Case operating temperature	T <sub>C</sub>	-40		+85	°C
Storage temperature	T <sub>ST</sub>	-55		+125	°C

**Note:** Exposure to maximum rating conditions for extended periods may reduce device reliability. There is no damage to device with only one parameter set at the limit and all other parameters set at or below their nominal values.

**Table 3. SKY65105 Recommended Operating Conditions**

Parameter	Symbol	Min	Typical	Max	Units
Supply voltage (VCC1 and VCC2)	V <sub>CC</sub>		5		V
Reference voltage	V <sub>REF</sub>		3.6		V
Operating frequency	F <sub>0</sub>	1700	1900	2200	MHz

**Table 4. SKY65105 Electrical Characteristics**

(V<sub>CC</sub> = 5.0 V, V<sub>REF</sub> = 3.6 V, Frequency = 1900 MHz, T<sub>C</sub> = 25 °C, unless otherwise noted)

Parameter	Symbol	Test Conditions	Min	Typical	Max	Units
<b>Analog Inputs</b>						
Frequency range			1700	1900	2200	MHz
Quiescent current	I <sub>Q</sub>			135	170	mA
Small signal gain	G	P <sub>IN</sub> = -15 dBm	22	23	25	dB
Output power	P <sub>OUT</sub>	P <sub>IN</sub> = 7 dBm	29	30		dBm
Efficiency	PAE	P <sub>IN</sub> = 7 dBm	30	37		%
Noise Figure (NF)	NF			4.5	6.0	dB
Output IP3	OIP3	Two tones with 100 kHz spacing, P <sub>IN</sub> = -1 dBm per tone	38	42		dBm
P <sub>OUT</sub> @ ACPR = -45 dBc	P <sub>OUT_ACPR</sub>	f = 1960 MHz	23	25		dBm
P <sub>OUT</sub> @ ACLR = -45 dBc	P <sub>OUT_ACLR</sub>	f = 2140 MHz	18	20		dBm

**Note:** The above specifications apply only to the 1900 MHz operating frequency.

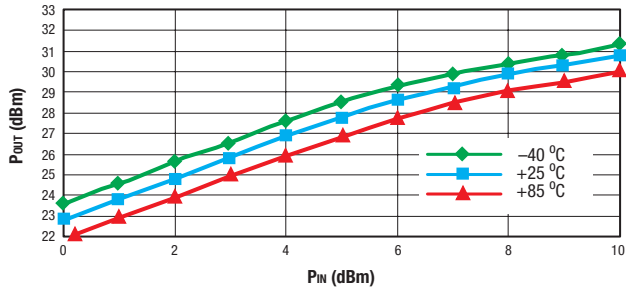

Figure 3. Typical Pout vs Pin Over Temperature

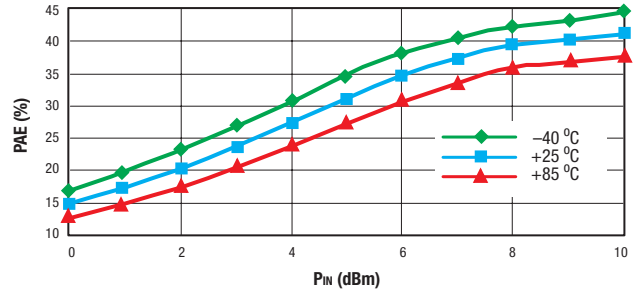

Figure 4. Typical PAE vs Pin Over Temperature

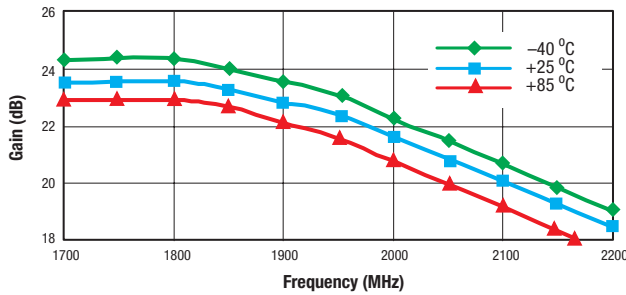

Figure 5. Typical Small Signal Gain vs Frequency Over Temperature

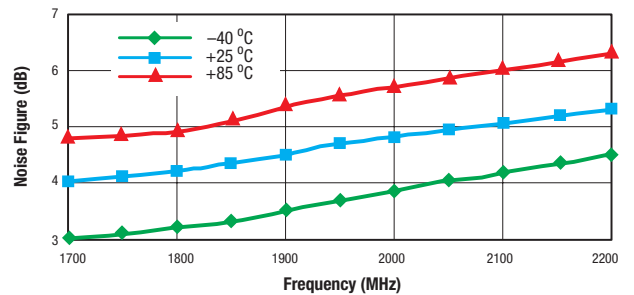

Figure 6. Typical Noise Figure vs Frequency Over Temperature

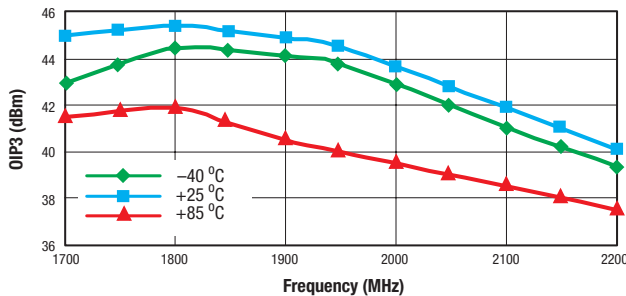

Figure 7. Typical OIP3 vs Frequency Over Temperature

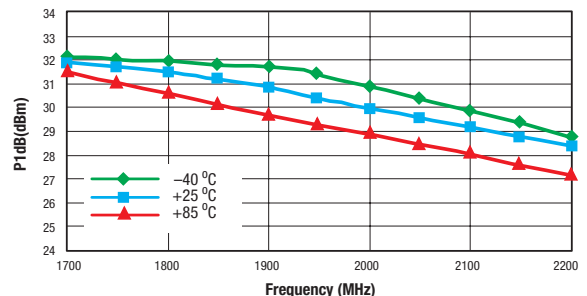
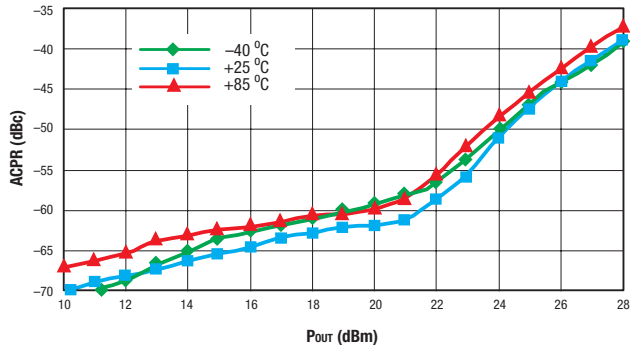
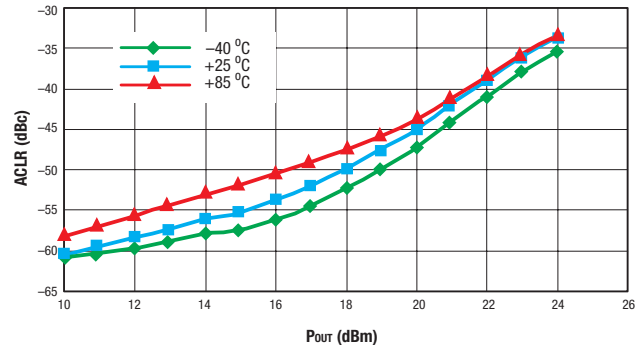

Figure 8. Typical P1dB vs Frequency Over Temperature



**Figure 9. Typical ACPR vs Pout Over Temperature (Using CDMA IS-95 Downlink Signal With Nine Channels)**



**Figure 10. Typical ACLR vs Pout Over Temperature (Using WCDMA 3GPP Downlink Test Model 1 With 64 DPCH)**

### Evaluation Board Description

Skyworks SKY65105 Evaluation Board is used to test the performance of the SKY65105 PA. The Evaluation Board schematic diagram is shown in Figure 11. The schematic shows the basic design of the board for the 1700 to 2200 MHz range. An assembly drawing for the Evaluation Board is shown in Figure 12 and the layer detail is provided in Figure 13.

### Circuit Design Considerations

The following design considerations are general in nature and must be followed regardless of final use or configuration

1. Paths to ground should be made as short as possible.
2. The ground pad of the SKY65105 PA has special electrical and thermal grounding requirements. This pad is the main thermal conduit for heat dissipation. Since the circuit board acts as the heat sink, it must shunt as much heat as possible from the amplifier. As such, design the connection to the ground pad to dissipate the maximum wattage produced to the circuit board. Multiple vias to the grounding layer are required.
3. Two external output bypass capacitors (0.01  $\mu$ F and 4.7  $\mu$ F) are required on the VCC1 (pin 12) supply input. The same two capacitors are also required on the VCC2 (pin 4) supply input. Both capacitors should be placed in parallel between the supply line and ground. Also, a bypass capacitor of 0.01  $\mu$ F is required on the VREF input (pin 3). See Figure 11 for a detailed diagram.
4. VCC1 (pin 12) and VCC2 (pin 4) may be connected together at the supply.

5. At the RF input (pin 2), a DC blocking capacitor is required.
6. The RF output includes an onboard internal DC blocking capacitor. All impedance matching is provided internally. Therefore, the application only needs to provide a good 50  $\Omega$  load.

### Testing Procedure

Use the following procedure to set up the SKY65105 Evaluation Board for testing. Refer to Figure 14 for guidance:

1. Connect a +5.0 V supply voltage to VCC1 and VCC2, and +3.6 V supply voltage to VREF. If available, enable the current limiting function of the power supplies to 1.0 A for the +5.0 V supply current and 30 mA for the +3.6 V supply current.
2. Connect a signal generator to the RF signal input port. Set it to the desired RF frequency at a power level of 7 dBm or less to the Evaluation Board but do NOT enable the RF signal.
3. Connect a spectrum analyzer to the RF signal output port.
4. Enable the power supply.
5. Enable the RF signal.
6. Take measurements.

---

**CAUTION:** *If the input signal exceeds the rated power, the SKY65105 Evaluation Board can be permanently damaged.*

---

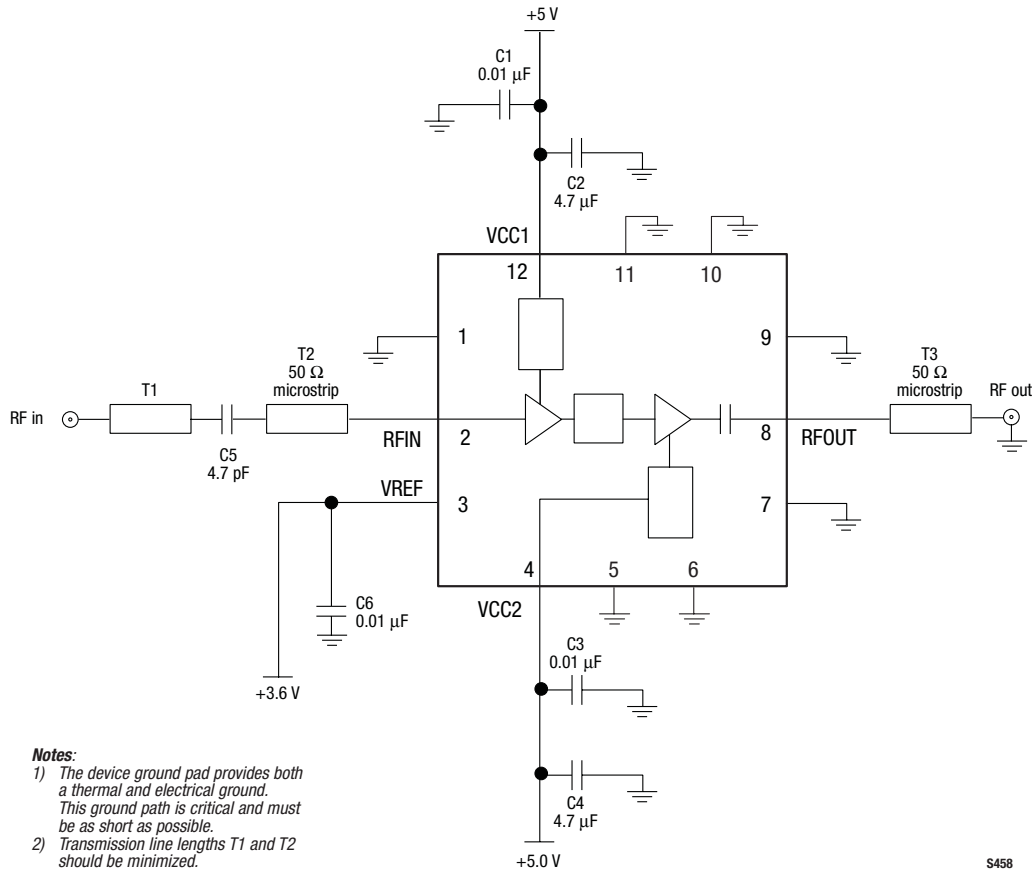

S458

**Figure 11. Evaluation Board Schematic, 1700 MHz to 2200 MHz**

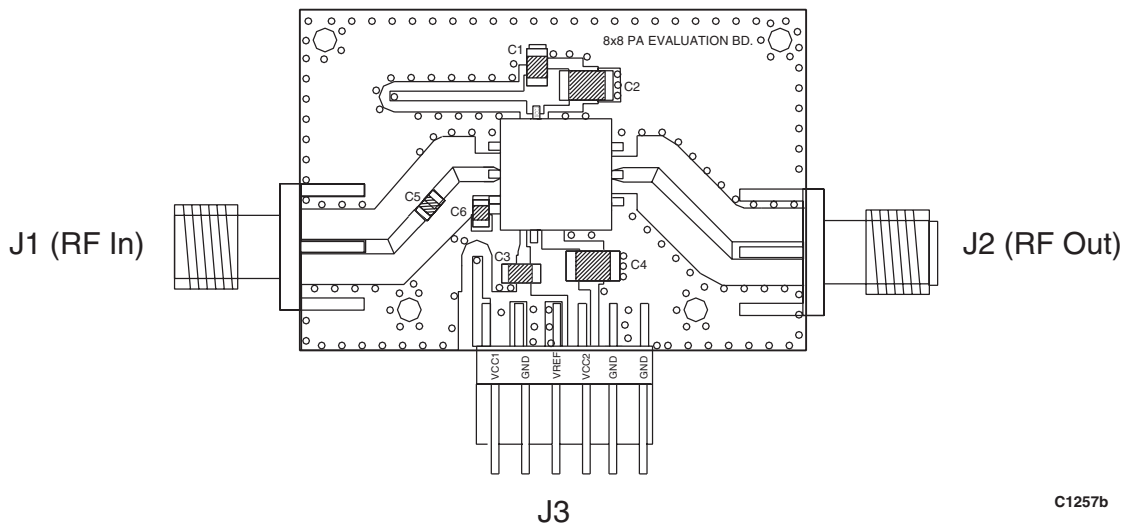

C1257b

**Figure 12. Evaluation Board Assembly Diagram**

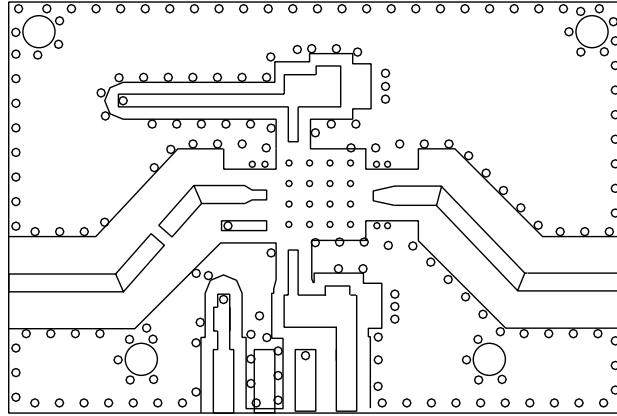

Layer 1: Top - Metal

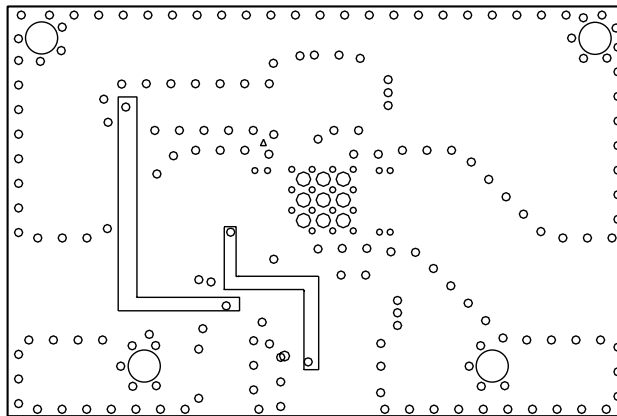

Layer 2: Inner Traces

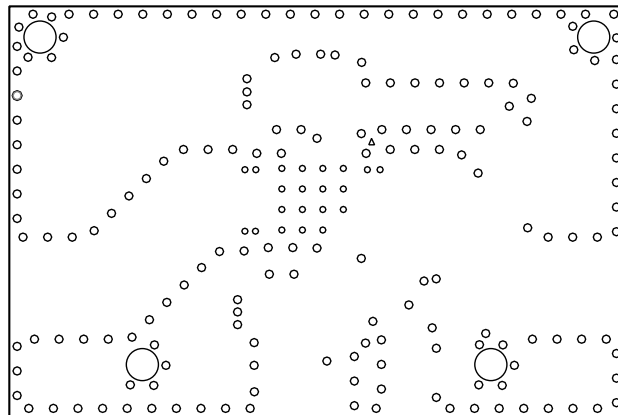

Layer 3: Solid Ground Plane

C1253d

**Figure 13. Evaluation Board Layer Detail**

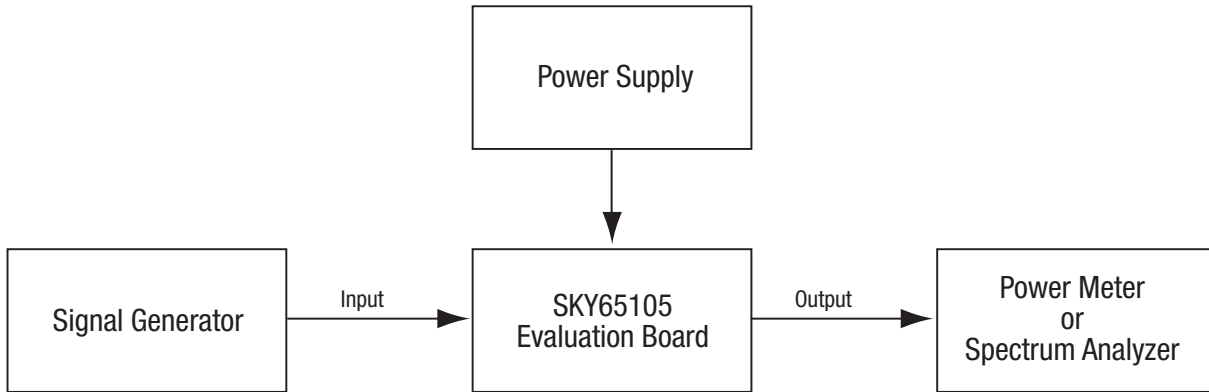

S457

**Figure 14. SKY65105 Evaluation Board Testing Configuration**

**Package Dimensions**

Figure 15 shows the package dimensions for the 12-pin MCM, and Figure 16 provides the tape and reel dimensions.

**Package and Handling Information**

Since the device package is sensitive to moisture absorption, it is baked and vacuum packed before shipping. Instructions on the shipping container label regarding exposure to moisture after the container seal is broken must be followed. Otherwise, problems related to moisture absorption may occur when the part is subjected to high temperature during solder assembly.

The SKY65105 is rated to Moisture Sensitivity Level 3 (MSL3) at 260 °C. It can be used for lead or lead-free soldering. For additional information, refer to Skyworks Application Note, *PCB*

*Design and SMT Assembly/Rework Guidelines for MCM-L Packages*, document number 101752.

Care must be taken when attaching this product, whether it is done manually or in a production solder reflow environment. Production quantities of this product are shipped in a standard tape and reel format. For packaging details, refer to the Skyworks Application Note, *Tape and Reel*, document number 101568.

**Electrostatic Discharge (ESD) Sensitivity**

The SKY65105 is a static-sensitive electronic device. Do not operate or store near strong electrostatic fields. Take proper ESD precautions.



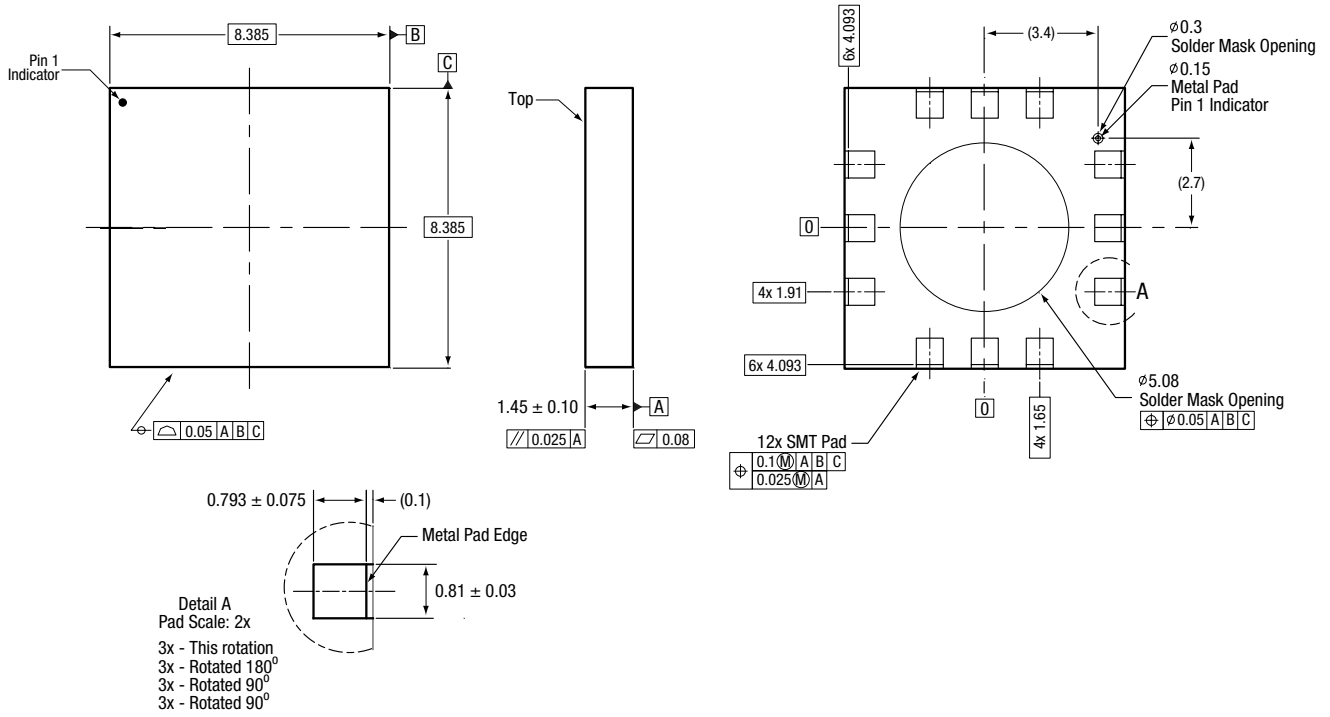

All measurements are in millimeters

S742

Figure 15. SKY65105 12-Pin MCM Package Dimensions

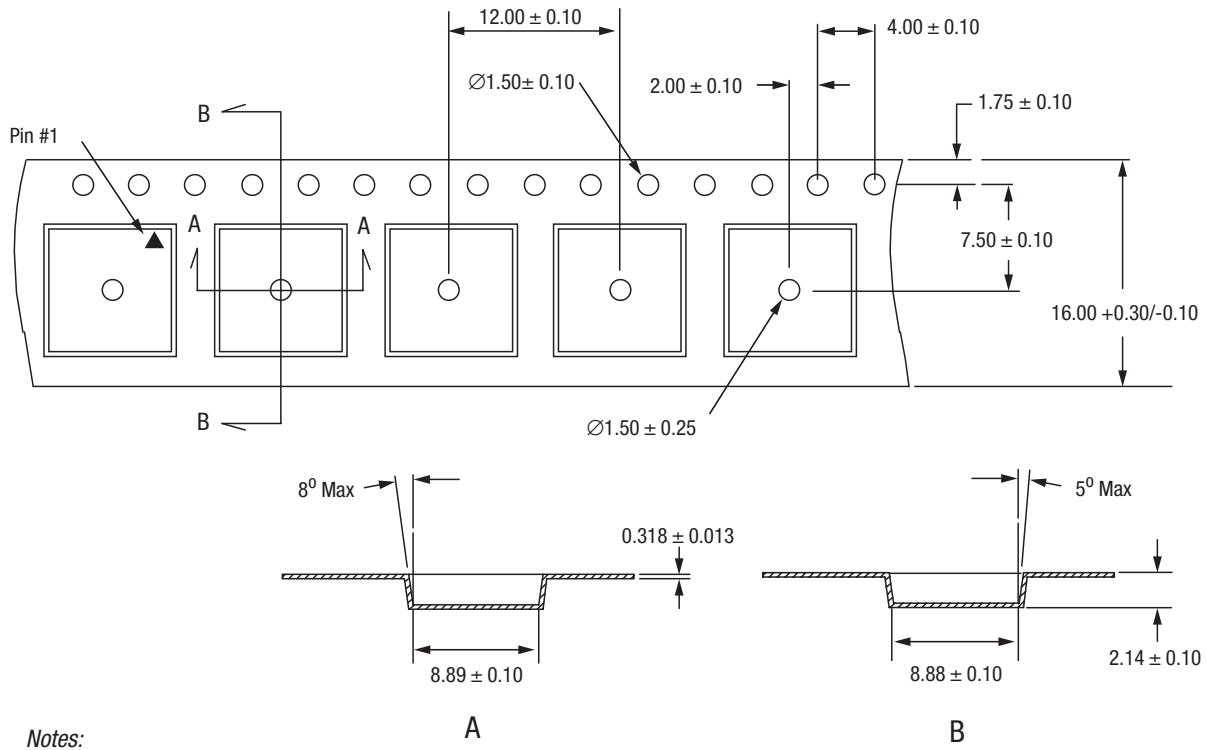

Notes:

1. Carrier tape: black conductive poly carbonate or polystyrene.
2. Cover tape material: transparent conductive PSA.
3. Cover tape size: 13.3 mm width.
4. All measurements are in millimeters.

C1221

Figure 16. SKY65105 12-Pin MCM Tape and Reel Dimensions

## Ordering Information

Model Name	Manufacturing Part Number	Evaluation Kit Part Number
SKY65105 1700-2200 MHz Linear Power Amplifier	SKY65105-21	TW10-D840

Copyright © 2006, 2007 Skyworks Solutions, Inc. All Rights Reserved.

Information in this document is provided in connection with Skyworks Solutions, Inc. ("Skyworks") products or services. These materials, including the information contained herein, are provided by Skyworks as a service to its customers and may be used for informational purposes only by the customer. Skyworks assumes no responsibility for errors or omissions in these materials or the information contained herein. Skyworks may change its documentation, products, services, specifications or product descriptions at any time, without notice. Skyworks makes no commitment to update the materials or information and shall have no responsibility whatsoever for conflicts, incompatibilities, or other difficulties arising from any future changes.

No license, whether express, implied, by estoppel or otherwise, is granted to any intellectual property rights by this document. Skyworks assumes no liability for any materials, products or information provided hereunder, including the sale, distribution, reproduction or use of Skyworks products, information or materials, except as may be provided in Skyworks Terms and Conditions of Sale.

THE MATERIALS, PRODUCTS AND INFORMATION ARE PROVIDED "AS IS" WITHOUT WARRANTY OF ANY KIND, WHETHER EXPRESS, IMPLIED, STATUTORY, OR OTHERWISE, INCLUDING FITNESS FOR A PARTICULAR PURPOSE OR USE, MERCHANTABILITY, PERFORMANCE, QUALITY OR NON-INFRINGEMENT OF ANY INTELLECTUAL PROPERTY RIGHT; ALL SUCH WARRANTIES ARE HEREBY EXPRESSLY DISCLAIMED. SKYWORKS DOES NOT WARRANT THE ACCURACY OR COMPLETENESS OF THE INFORMATION, TEXT, GRAPHICS OR OTHER ITEMS CONTAINED WITHIN THESE MATERIALS. SKYWORKS SHALL NOT BE LIABLE FOR ANY DAMAGES, INCLUDING BUT NOT LIMITED TO ANY SPECIAL, INDIRECT, INCIDENTAL, STATUTORY, OR CONSEQUENTIAL DAMAGES, INCLUDING WITHOUT LIMITATION, LOST REVENUES OR LOST PROFITS THAT MAY RESULT FROM THE USE OF THE MATERIALS OR INFORMATION, WHETHER OR NOT THE RECIPIENT OF MATERIALS HAS BEEN ADVISED OF THE POSSIBILITY OF SUCH DAMAGE.

Skyworks products are not intended for use in medical, lifesaving or life-sustaining applications, or other equipment in which the failure of the Skyworks products could lead to personal injury, death, physical or environmental damage. Skyworks customers using or selling Skyworks products for use in such applications do so at their own risk and agree to fully indemnify Skyworks for any damages resulting from such improper use or sale.

Customers are responsible for their products and applications using Skyworks products, which may deviate from published specifications as a result of design defects, errors, or operation of products outside of published parameters or design specifications. Customers should include design and operating safeguards to minimize these and other risks. Skyworks assumes no liability for applications assistance, customer product design, or damage to any equipment resulting from the use of Skyworks products outside of stated published specifications or parameters.

Skyworks, the Skyworks symbol, and "Breakthrough Simplicity" are trademarks or registered trademarks of Skyworks Solutions, Inc., in the United States and other countries. Third-party brands and names are for identification purposes only, and are the property of their respective owners. Additional information, including relevant terms and conditions, posted at [www.skyworksinc.com](http://www.skyworksinc.com), are incorporated by reference.