

Surface Mount Chip LEDs

MSL-1947HB3-5

Description

The MSL-1947HB3-5, a BLUE source Chip LED device, is designed in an industry standard package suitable for SMT assembly method. It utilizes GaN on Sapphire LED chip technology and water clear epoxy package.

Applications

- Small Size (Extra Thin)
- Industry Standard Footprint(0603)
- Compatible with IR Solder process
- Available in 8 mm Tape on 7"(178mm) Diameter Reels

Features

- Push-Button Backlighting
- LCD Backlighting
- Symbol Backlighting
- Front Panel Indicator

Package Dimensions

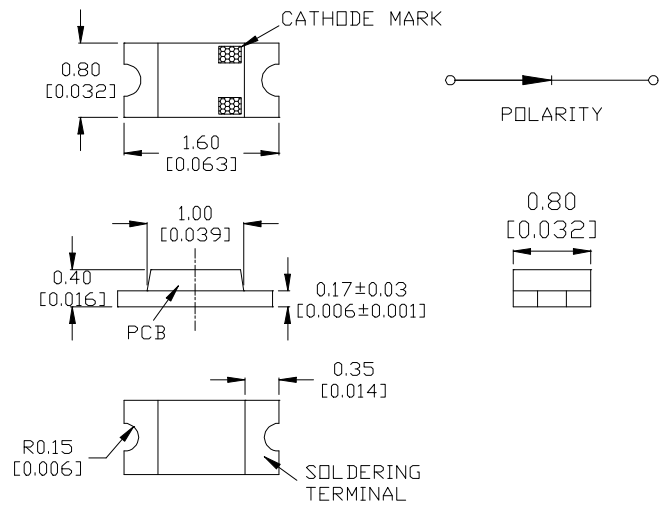

Recommended Solder Patterns

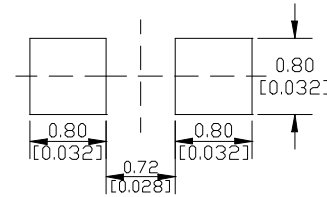

NOTE:

1. All dimensions are in millimeter (inches)
2. Tolerance is $\pm 0.15\text{mm}$ (.006") unless otherwise specified.

Absolute Maximum Ratings

@ $T_A=25^\circ\text{C}$

Parameter	Symbol	Maximum Rating	Unit
Peak Forward Current(1/10 Duty Cycle@1KHz)	I_{FP}	100	mA
DC Forward Current	I_F	30	mA
Power Dissipation	P_D	125	mW
Reverse Voltage	V_R	5	V
Electrostatic Discharge Threshold (HBM) ^{Note A}	E_{OT}	300	V
Operating Temperature Range	T_{OPR}	-25°C to +80°C	
Storage Temperature Range	T_{STG}	-30°C to +100°C	

Note A : HBM(Human Body Model)



Unity Opto Technology Co., Ltd.

Optical-Electrical Characteristics

@ T_A=25°C

Item	Conditions	Symbol	Min .	Typ .	Max .	Unit .
Luminous Intensity*1	I _F =5mA	I _V	11	-	-	mcd
Forward Voltage*1	I _F =5mA	V _F	2.7	-	3.5	V
Dominant Wavelength*1	I _F =5mA	λ _d	465	470	475	nm
Threshold Voltage	I _F =10uA	V _{th}	2.0	-	3.0	V
Reverse Voltage	I _R =10uA	V _R	10.0	-	-	V
Reverse Current	V _R =5V	I _R	-	-	50.0	μA

*1)These values measured by Optical Spectrum Analyzer of UnityOpto Co., Ltd and tolerances are followings as below

-Luminous Intensity(I_v):± 2mcd, Forward Voltage(V_F):± 0.2V, Dominant Wavelength(λ_d):± 2nm

Typical Optical-Electrical Characteristic Curves

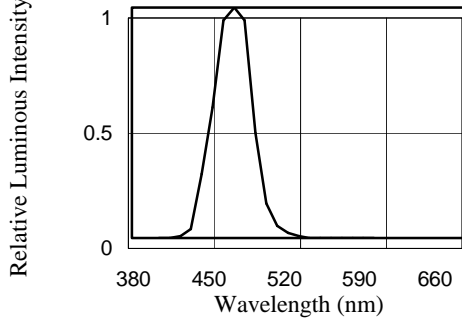

FIG.1 RELATIVE INTENSITY LUMINOUS VS. WAVELENGTH

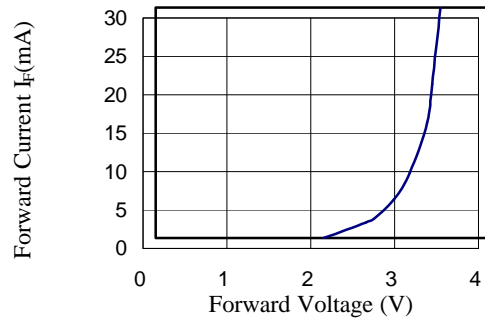

FIG.2 FORWARD CURRENT I_F (mA) VS. FORWARD VOLTAGE

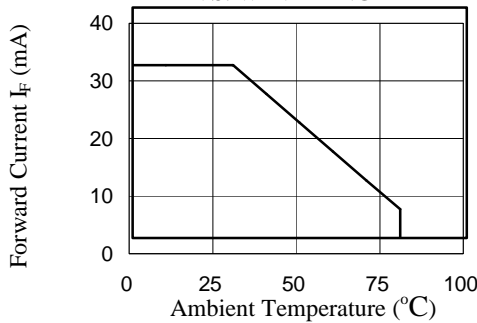

FIG.3 FORWARD CURRENT VS. AMBIENT TEMPERATURE

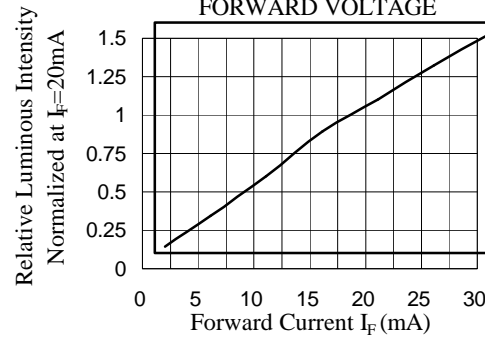

FIG.4 RELATIVE LUMINOUS INTENSITY VS. FORWARD CURRENT

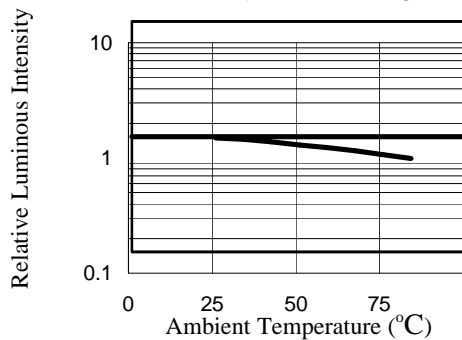

FIG.5 LUMINOUS INTENSITY VS. AMBIENT TEMPERATURE

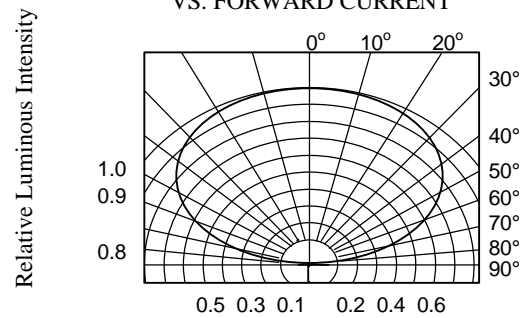

FIG.6 RADIATION DIAGRAM

Sorting For Luminous Intensity And Dominant Wavelength

Rank Markings	Forward Voltage Vf (V) I _F =5mA		Luminous Intensity Iv(mcd) I _F =5mA		Dominant Wavelength Id(nm) I _F =5mA	
	Min	Max	Min	Max	Min	Max
Code						
A1	2.75	2.85	11	35	465	470
A2					470	475
A3					475	480
A4					480	485
B1	2.85	2.95			465	470
B2					470	475
B3					475	480
B4					480	485
C1	2.95	3.05			465	470
C2					470	475
C3					475	480
C4					480	485
D1	3.05	3.15			465	470
D2					470	475
D3					475	480
D4					480	485
E1	3.15	3.25	465	470		
E2			470	475		
E3			475	480		
E4			480	485		

GaN LED HANDLING PRECAUTION

The blue LED is a device that is very sensitive to surge voltage produced when static electricity is discharged. Handling with sufficient care is needed to prevent damage to a chip or a drop in its reliability.

Also, the same handling care is needed when applying voltage over the absolute maximum rating.

(Be aware of surge voltage produced when you turn the on-off switch)

How to prevent electrical charge and discharge during operation

If the person who is electrically charged touches the part, there is a possibility of electric discharge toward the semiconductor device which may destroy the part, if the part is electrically charged inductively by the surroundings, or the part is electrically charged by friction and touches metal, the part may discharge static and cause damage.

During your operations, please take these countermeasures written below.

1. Do not let material which is electrically charged get close to the part.
(Avoid contact with metal when the part is electrically charged)
2. Avoid any friction process with the part
3. Be sure to ground all manufacturing machines and measuring instruments if possible
4. Make an anti-static environment, such as placing electrically conductive mat (below $10^6\Omega$) or using anti-static equipment such as static blow

Let the worker wear the anti-static wrist strap, (Electrical resistance of 250K-1M Ω must be placed in series to avoid an electric shock.)

Working Environment

In case of semiconductor device, static occurs easily in dry condition. Especially the surface mount led should be kept in a dry environment to avoid moisture absorbency. But a relative humidity of 50% or more is recommended for the process after the soldering.

Static level should be kept under 300V at your working area.

RECOMMENDED SOLDERING CONDITION

Reflow Soldering.

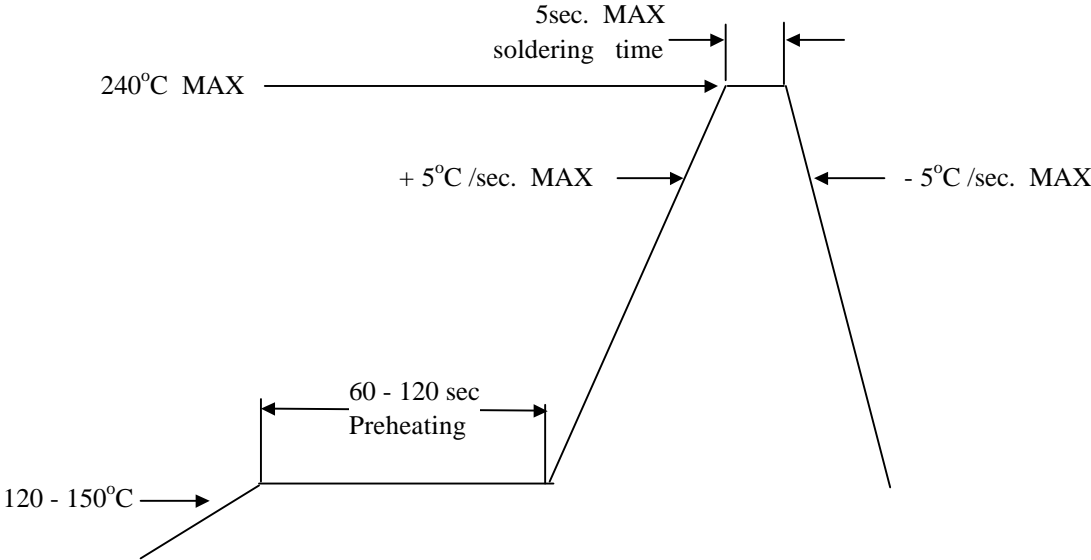

Recommended Soldering Conditions

1.Reflow Soldering

- (1).The Fig. 1 temperature profile shall be at the surface of LED resin.
- (2).Number of reflow process shall be less than 2 times.
If second reflow process would be performed,intervals between first and second process shall be as short as possible to prevent absorption of moisture to resin of LED
Cooling process to normal temp,shall be required between first and second reflow process
- (3).Temp.fluctuation to LED at pre-heat process shall be minimized.(Less than 6°C)

2.Dip Soldering

- (1).Preheat temp,for soldering:120-150°C ,60-120sec
- (2).Soldering temp:Temp of soldering pot 260 MAX.less than 5sec
- (3).Number of dip soldering process shall be less than 2 times and these process shall be performed in a row.
Cooling process to normal temp,shall be required between first and second soldering process.

3.Other Caution

- (1).Manual soldering should be less than 280°C within 3 sec.
- (2).Heat or UV(or both)curing resin shall used for preliminary fixing.
Curing condition or temp,:150°C MAX.less than 120sec
- (3).Any mechanical force or any excess vibration shall not be accepted to apply during cooling process to normal temp,after soldering
- (4).If manual soldering would be performed to repair LED by tweezers, mechanical force to resin should not be given

Tape Dimensions

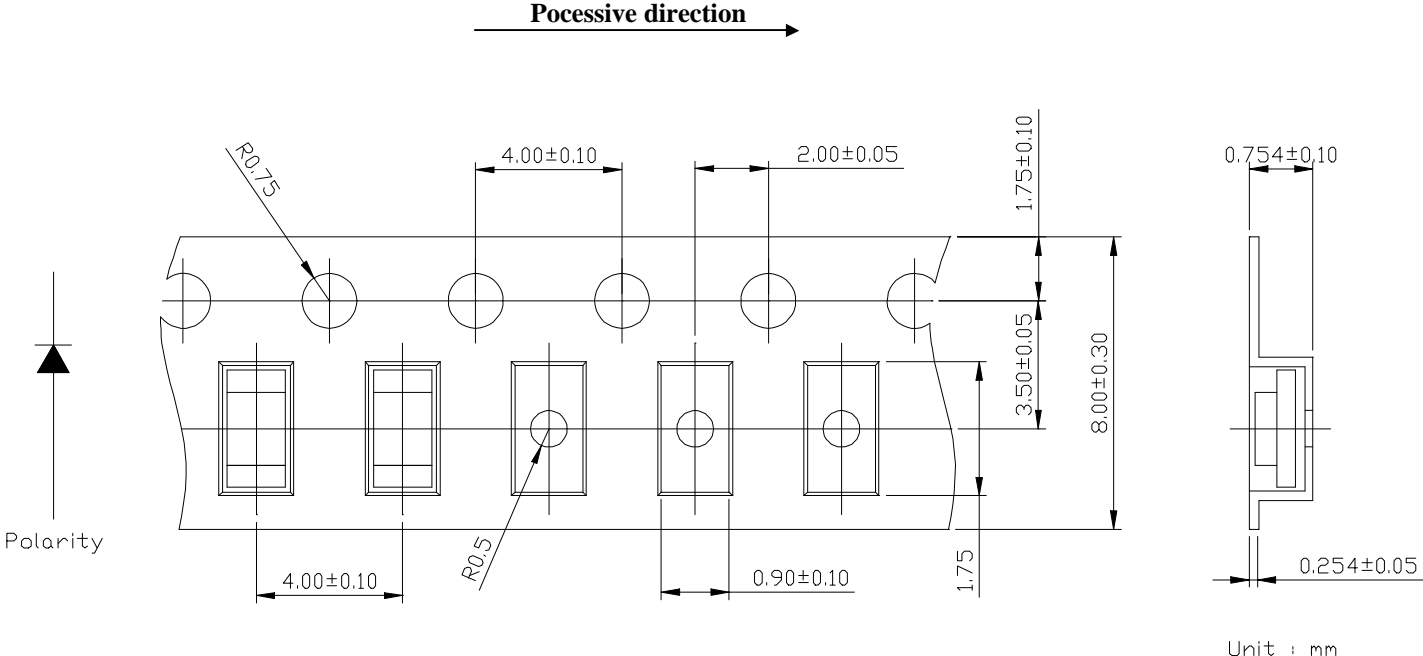

REEL Dimensions

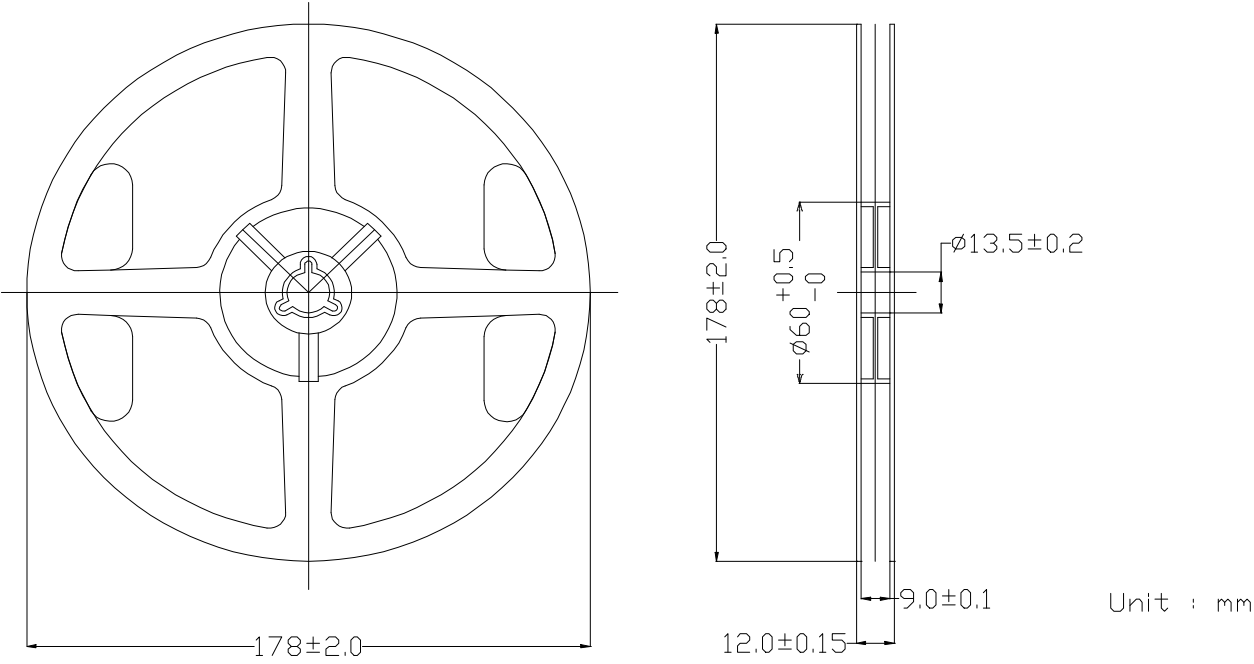

Packaging

Loaded quantity per reel : 4000 pcs / reel

Product lable:

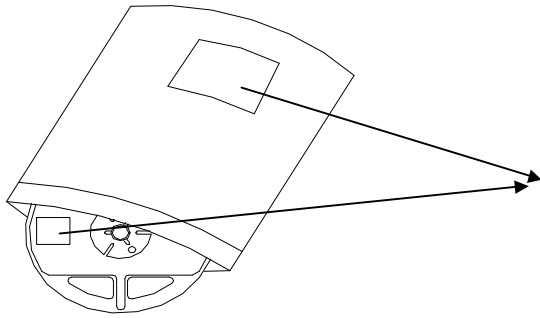

CUSTOMER:
CUSTOMER P/N:
DEVICE TYPE:
BIN:
LOT NO:
Q'TY:
DATE:

STORAGE PERIOD: Damp-proofbag un-opened: 6 month max.

Temperature: 5 to 30°C; humidity:70%RH, max; 6 month max.

STORAGE PRECAUTIONS: After open the laminate bag the lamps should be storage in the follow condition:

Temperature: 5 to 30°C; humidity:70%RH, max; storage time: 72hrs max

Baking condition: If backing is necessary, we recommended the backing condition is 60+/- 5°C 10hours

Packing Box

Loaded quantity per box : 20,000 pcs / box

Product lable:

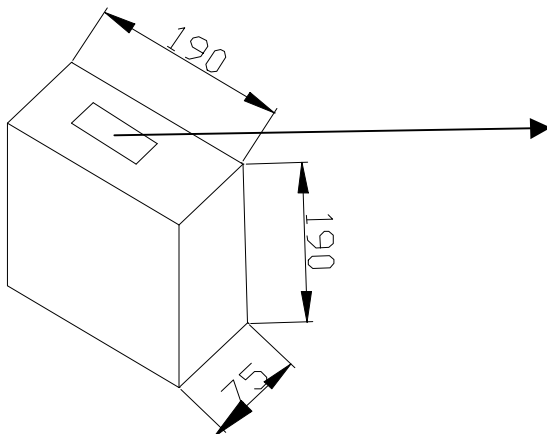

CUSTOMER:
CUSTOMER P/N:
DEVICE TYPE:
BIN:
LOT NO:
Q'TY:
DATE:

Reel Packing

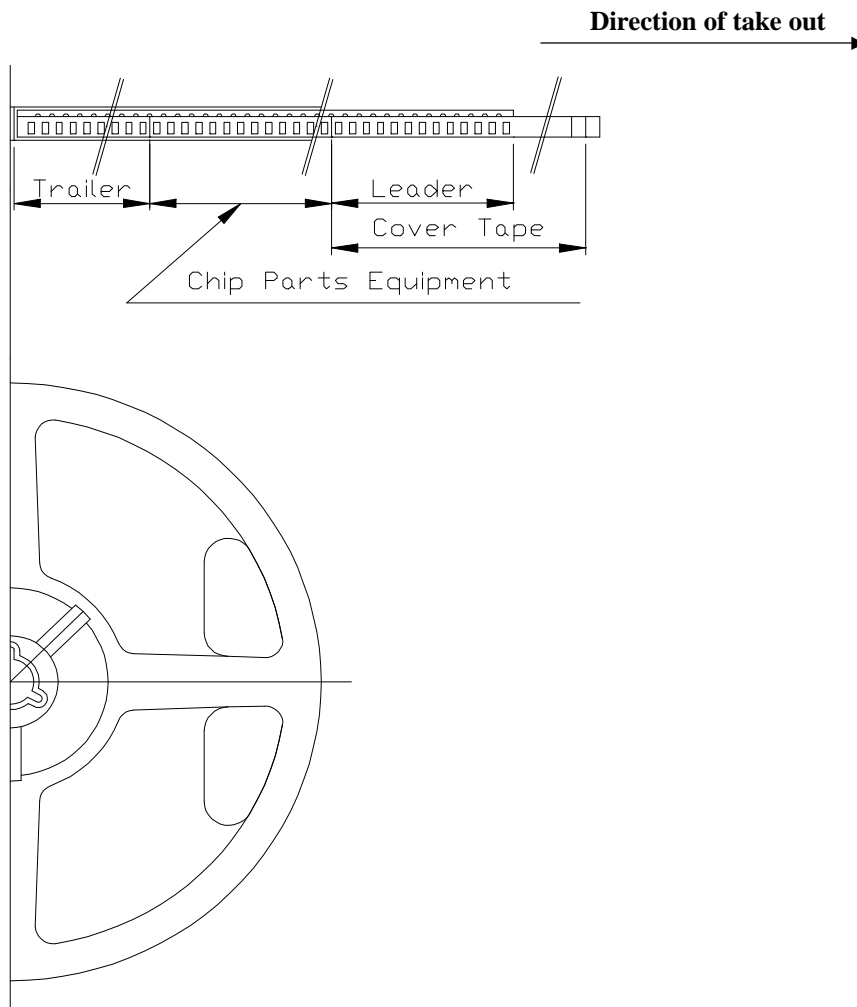

Items		Specifications	Remarks
Leader	Cover Tape	Cover tape shall be longer than 200 mm without carrier tape	The end of the tape shall be adhered to tape
	Carrier Tape	There will be more than 10 empties	The orientation of tape is as shown
Traier		There will be more than 15 empties	The end of the tape is inserted into a slit of the hub
	Empty Pockets	There will be a maximum of 3 empty component pockets	The maximum connecting pockets in the middle of carrier-tape

Surface Mount Moisture Sensitivity Specifications

1. Controlling Moisture

Unity Opto Technology, in its design of packing materials and packing methods, takes into consideration the susceptibility of some Unity packages to moisture induced damage. The risk of this damage is caused when the LED lens plastic encapsulation material is exposed to increases or decreases in the Relative Humidity of the surrounding environment.

Such damage may include delamination between the die and the LED lens plastic encapsulation material, which may result in open connections due to broken wire bonds. Moisture in the package having reached a critical level will fracture the package in order to escape when exposed to peak temperature conditions, typical in soldering practices.

Therefore, the control of moisture levels in the LED package is critical to reduce the risk of moisture-induced failures. Please follow JEDEC-STD-033A standards for handling moisture sensitive devices.

2. Packaging SMD devices:

Unity packages all SMD devices into dry pack bags (moisture barrier bags).

Unity includes a desiccant pouch in each bag. Testing confirms that the desiccant pouch greatly reduces the presence of moisture by maintaining the environment in the bag, thus protecting the devices during shipment and storage.

3. Handling Dry Packed Parts

Upon receipt, the bags should be inspected for damage to ensure that the bag's integrity has been maintained. Inspection should verify that there are no holes, gouges, tears, or punctures of any kind that may expose the contents of the bag.

To open the bag, simply cut across the top of the bag as close to the original seal as possible being careful not to damage the contents. Once open the desired quantity of units should be removed and the bag resealed. If the bag is left open longer than 2 hours, the desiccant pouch should be replaced with a dry desiccant and the bag should be sealed immediately to avoid moisture damage.