

Description

The **ICS9FG104** is a Frequency Timing Generator that provides 4 differential output pairs that are compliant to the Intel CK410 specification. It also provides support for PCI-Express and SATA. The part synthesizes several output frequencies from either a 14.31818 Mhz crystal or a 25 MHz crystal. The device can also be driven by a reference input clock instead of a crystal. It provides outputs with cycle-to-cycle jitter of less than 50 ps and output-to-output skew of less than 35 ps. The **ICS9FG104** also provides a copy of the reference clock. Frequency selection can be accomplished via strap pins or SMBus control.

Key Specifications

- Output cycle-to-cycle jitter < 50 ps
- Output to output skew < 35 ps
- +/-300 ppm frequency accuracy on output clocks
- +/- 150 ppm frequency accuracy @ 100 MHz outputs
- 28-pin SSOP/TSSOP package
- Available in RoHS compliant packaging

Features/Benefits

- Generates common frequencies from 14.318 MHz or 25 MHz
- Crystal or reference input
- 4 - 0.7V current-mode differential output pairs
- Supports Serial-ATA at 100 MHz
- Two spread spectrum modes: 0 to -0.5 downspread and +/-0.25% centerspread
- Unused inputs may be disabled in either driven or Hi-Z state for power management.
- M/N Programming

Funtional Block Diagram

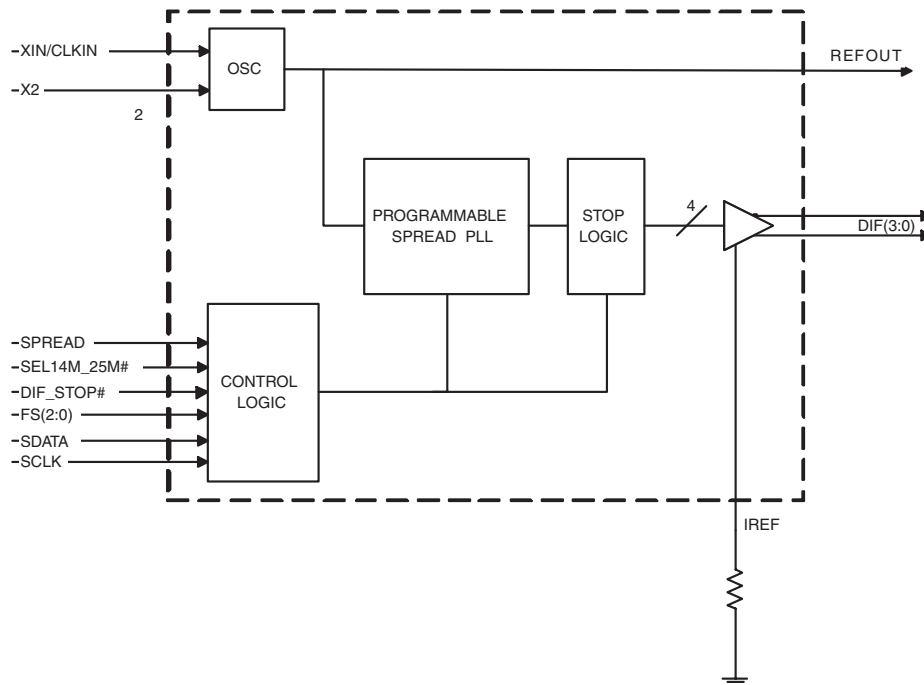

Pin Configuration

XIN/CLKIN	1	ICS9FG104	28	VDDA
X2	2		27	GNDA
VDD	3		26	IREF
GND	4		25	**FS0
REFOUT	5		24	**FS1
**FS2	6		23	DIF_0
DIF_3	7		22	DIF_0#
DIF_3#	8		21	VDD
VDD	9		20	GND
GND	10		19	DIF_1
DIF_2	11		18	DIF_1#
DIF_2#	12		17	*SEL14M_25M#
SDATA	13		16	**SPREAD
SCLK	14		15	DIF_STOP#

* Pin has internal 120K pull up

** Pin has internal 120K pull down

28-pin SSOP/TSSOP

Functionality Table

SEL14M_25M# (FS3)	FS2	FS1	FS0	OUTPUT(MHz)
0	0	0	0	100.00
0	0	0	1	125.00
0	0	1	0	133.33
0	0	1	1	166.67
0	1	0	0	200.00
0	1	0	1	266.00
0	1	1	0	333.00
0	1	1	1	400.00
1	0	0	0	100.00
1	0	0	1	125.00
1	0	1	0	133.33
1	0	1	1	166.67
1	1	0	0	200.00
1	1	0	1	266.00
1	1	1	0	333.00
1	1	1	1	400.00

Power Groups

Pin Number		Description
VDD	GND	
3	4	REFOUT, Digital Inputs
9,21	10,20	DIF Outputs
28	27	IREF, Analog VDD, GND for PLL Core

Pin Description

PIN #	PIN NAME	PIN TYPE	DESCRIPTION
1	XIN/CLKIN	IN	Crystal input or Reference Clock input
2	X2	OUT	Crystal output, Nominally 14.318MHz
3	VDD	PWR	Power supply, nominal 3.3V
4	GND	PWR	Ground pin.
5	REFOUT	OUT	Reference Clock output
6	FS2**	IN	Frequency select pin.
7	DIF_3	OUT	0.7V differential true clock output
8	DIF_3#	OUT	0.7V differential complement clock output
9	VDD	PWR	Power supply, nominal 3.3V
10	GND	PWR	Ground pin.
11	DIF_2	OUT	0.7V differential true clock output
12	DIF_2#	OUT	0.7V differential complement clock output
13	SDATA	I/O	Data pin for SMBus circuitry, 5V tolerant.
14	SCLK	IN	Clock pin of SMBus circuitry, 5V tolerant.
15	DIF_STOP#	IN	Active low input to stop differential output clocks.
16	SPREAD**	IN	Asynchronous, active high input, with internal 120Kohm pull-up resistor, to enable spread spectrum functionality.
17	SEL14M_25M#*	IN	Select 14.31818 MHz or 25 Mhz input frequency. 1 = 14.31818 MHz, 0 = 25 MHz
18	DIF_1#	OUT	0.7V differential complement clock output
19	DIF_1	OUT	0.7V differential true clock output
20	GND	PWR	Ground pin.
21	VDD	PWR	Power supply, nominal 3.3V
22	DIF_0#	OUT	0.7V differential complement clock output
23	DIF_0	OUT	0.7V differential true clock output
24	FS1**	IN	3.3V Frequency select latched input pin.
25	FS0**	IN	3.3V Frequency select latched input pin.
26	IREF	OUT	This pin establishes the reference current for the differential current-mode output pairs. This pin requires a fixed precision resistor tied to ground in order to establish the appropriate current. 475 ohms is the standard value.
27	GNDA	PWR	Ground pin for the PLL core.
28	VDDA	PWR	3.3V power for the PLL core.

General SMBus serial interface information for the ICS9FG104

How to Write:

- Controller (host) sends a start bit.
- Controller (host) sends the write address $DC_{(H)}$
- ICS clock will **acknowledge**
- Controller (host) sends the beginning byte location = N
- ICS clock will **acknowledge**
- Controller (host) sends the data byte count = X
- ICS clock will **acknowledge**
- Controller (host) starts sending **Byte N through Byte N + X - 1**
(see Note 2)
- ICS clock will **acknowledge** each byte **one at a time**
- Controller (host) sends a Stop bit

How to Read:

- Controller (host) will send start bit.
- Controller (host) sends the write address $DC_{(H)}$
- ICS clock will **acknowledge**
- Controller (host) sends the beginning byte location = N
- ICS clock will **acknowledge**
- Controller (host) will send a separate start bit.
- Controller (host) sends the read address $DD_{(H)}$
- ICS clock will **acknowledge**
- ICS clock will send the data byte count = X
- ICS clock sends **Byte N + X - 1**
- ICS clock sends **Byte 0 through byte X (if $X_{(H)}$ was written to byte 8).**
- Controller (host) will need to acknowledge each byte
- Controller (host) will send a not acknowledge bit
- Controller (host) will send a stop bit

Index Block Write Operation		
Controller (Host)		ICS (Slave/Receiver)
T	starT bit	
Slave Address $DC_{(H)}$		
WR	WRite	
		ACK
Beginning Byte = N		
		ACK
Data Byte Count = X		
		ACK
Beginning Byte N	X Byte	
○		ACK
○		○
○		○
Byte N + X - 1		○
		ACK
P	stoP bit	

Index Block Read Operation		
Controller (Host)		ICS (Slave/Receiver)
T	starT bit	
Slave Address $DC_{(H)}$		
WR	WRite	
		ACK
Beginning Byte = N		
		ACK
RT	Repeat starT	
Slave Address $DD_{(H)}$		
RD	ReaD	
		ACK
		Data Byte Count = X
ACK		
ACK		Beginning Byte N
○		○
○		○
○		○
		Byte N + X - 1
N	Not acknowledge	
P	stoP bit	

SMBus Table: Device Control Register, READ/WRITE ADDRESS (DC/DD)

Byte 0	Pin #	Name	Control Function	Type	0	1	PWD
Bit 7	17		FS3 ¹	RW	See Frequency Selection Table, Page 1		Pin 17
Bit 6	6		FS2 ¹	RW			Pin 6
Bit 5	24		FS1 ¹	RW			Pin 24
Bit 4	25		FS0 ¹	RW			Pin 25
Bit 3	16		Spread Enable ¹	RW	Off	On	Pin 16
Bit 2	-	Enable Software Control of Frequency, Spread Enable (Spread Type always Software Control)		RW	Hardware Select	Software Select	0
Bit 1			DIF_STOP# drive mode	RW	Driven	Hi-Z	0
Bit 0			SPREAD TYPE	RW	Down	Center	0

Notes:

1. These bits reflect the state of the corresponding pins at power up, but may be written to if Byte 0, bit 2 is set to '1'. FS3 is the SEL14M_25M# pin.

SMBus Table: Output Enable Register

Byte 1	Pin #	Name	Control Function	Type	0	1	PWD
Bit 7	-	Reserved					1
Bit 6	-	DIF_3 EN	Output Enable	RW	Disable	Enable	1
Bit 5	-	DIF_2 EN	Output Enable	RW	Disable	Enable	1
Bit 4	-	Reserved					1
Bit 3	-	Reserved					1
Bit 2	-	DIF_1 EN	Output Enable	RW	Disable	Enable	1
Bit 1	-	DIF_0 EN	Output Enable	RW	Disable	Enable	1
Bit 0	-	Reserved					1

SMBus Table: Output Stop Control Register

Byte 2	Pin #	Name	Control Function	Type	0	1	PWD
Bit 7	-	Reserved					0
Bit 6	-	DIF_3 STOP EN	Free Run/ Stop Enable	RW	Free-run	Stop-able	0
Bit 5	-	DIF_2 STOP EN	Free Run/ Stop Enable	RW	Free-run	Stop-able	0
Bit 4	-	Reserved					0
Bit 3	-	Reserved					0
Bit 2	-	DIF_1 STOP EN	Free Run/ Stop Enable	RW	Free-run	Stop-able	0
Bit 1	-	DIF_0 STOP EN	Free Run/ Stop Enable	RW	Free-run	Stop-able	0
Bit 0	-	Reserved					0

SMBus Table: Frequency Select Readback Register

Byte 3	Pin #	Name	Control Function	Type	0	1	PWD
Bit 7	27	SEL14M_25M# ¹ (FS3)	State of pin 17	R	See Frequency Selection Table, Page 1		Pin 17
Bit 6	6	FS2 ¹	State of pin 6	R			Pin 6
Bit 5	44	FS1 ¹	State of pin 24	R			Pin 24
Bit 4	45	FS0 ¹	State of pin 25	R			Pin 25
Bit 3	16	SPREAD ¹	State of pin 26	R	Off	On	Pin 16
Bit 2			Reserved				0
Bit 1			Reserved				0
Bit 0			Reserved				0

Notes:

1. These bits reflect the state of the corresponding pins, regardless of whether software programming is enabled or not.

SMBus Table: Vendor & Revision ID Register

Byte 4	Pin #	Name	Control Function	Type	0	1	PWD
Bit 7	-	RID3	REVISION ID	R	-	-	X
Bit 6	-	RID2		R	-	-	X
Bit 5	-	RID1		R	-	-	X
Bit 4	-	RID0		R	-	-	X
Bit 3	-	VID3	VENDOR ID	R	-	-	0
Bit 2	-	VID2		R	-	-	0
Bit 1	-	VID1		R	-	-	0
Bit 0	-	VID0		R	-	-	1

SMBus Table: DEVICE ID

Byte 5	Pin #	Name	Control Function	Type	0	1	PWD
Bit 7	-	DID7	Device ID = 08 hex	RW	-	-	0
Bit 6	-	DID6		RW	-	-	0
Bit 5	-	DID5		RW	-	-	0
Bit 4	-	DID4		RW	-	-	0
Bit 3	-	DID3		RW	-	-	1
Bit 2	-	DID2		RW	-	-	0
Bit 1	-	DID1		RW	-	-	0
Bit 0	-	DID0		RW	-	-	0

SMBus Table: Byte Count Register

Byte 6	Pin #	Name	Control Function	Type	0	1	PWD
Bit 7	-	BC7	Writing to this register will configure how many bytes will be read back, default is 07 = 7 bytes.	RW	-	-	0
Bit 6	-	BC6		RW	-	-	0
Bit 5	-	BC5		RW	-	-	0
Bit 4	-	BC4		RW	-	-	0
Bit 3	-	BC3		RW	-	-	0
Bit 2	-	BC2		RW	-	-	1
Bit 1	-	BC1		RW	-	-	1
Bit 0	-	BC0		RW	-	-	1

SMBus Table: Reserved Register

Byte 7	Pin #	Name	Control Function	Type	0	1	PWD
Bit 7	-		Reserved				0
Bit 6	-		Reserved				0
Bit 5	-		Reserved				0
Bit 4	-		Reserved				0
Bit 3	-		Reserved				0
Bit 2	-		Reserved				0
Bit 1	-		Reserved				0
Bit 0	-		Reserved				0

SMBus Table: Reserved Register

Byte 8	Pin #	Name	Control Function	Type	0	1	PWD
Bit 7	-		Reserved				0
Bit 6	-		Reserved				0
Bit 5	-		Reserved				0
Bit 4	-		Reserved				0
Bit 3	-		Reserved				0
Bit 2	-		Reserved				0
Bit 1	-		Reserved				0
Bit 0	-		Reserved				0

SMBus Table: M/N Programming Enable

Byte 9	Pin #	Name	Control Function	Type	0	1	PWD
Bit 7	-	M/N_Enable	M/N Prog. Enable	RW	Disable	Enable	0
Bit 6	-		Reserved				1
Bit 5	5	REFOUT_En	REFOUT Enable	RW	Disable	Enable	1
Bit 4	-		Reserved				0
Bit 3	-		Reserved				0
Bit 2	-		Reserved				0
Bit 1	-		Reserved				0
Bit 0	-		Reserved				0

SMBus Table: PLL Frequency Control Register

Byte 10	Pin #	Name	Control Function	Type	0	1	PWD
Bit 7	-	PLL N Div8	N Divider Prog bit 8	RW	The decimal representation of M and N Divider in Byte 11 and 12 will configure the PLL VCO frequency. Default at power up = latch-in or Byte 0 Rom table. VCO Frequency = $14.318 \times [\text{NDiv}(9:0)+8] / [\text{MDiv}(5:0)+2]$		X
Bit 6	-	PLL N Div9	N Divider Prog bit 9	RW			X
Bit 5	-	PLL M Div5	M Divider Programming bit (5:0)	RW			X
Bit 4	-	PLL M Div4		RW			X
Bit 3	-	PLL M Div3		RW			X
Bit 2	-	PLL M Div2		RW			X
Bit 1	-	PLL M Div1		RW			X
Bit 0	-	PLL M Div0		RW			X

SMBus Table: PLL Frequency Control Register

Byte 11	Pin #	Name	Control Function	Type	0	1	PWD
Bit 7	-	PLL N Div7	N Divider Programming Byte11 bit(7:0) and Byte10 bit(7:6)	RW	The decimal representation of M and N Divider in Byte 11 and 12 will configure the PLL VCO frequency. Default at power up = latch-in or Byte 0 Rom table. VCO Frequency = 14.318 x [NDiv(9:0)+8] / [MDiv(5:0)+2]		X
Bit 6	-	PLL N Div6		RW			X
Bit 5	-	PLL N Div5		RW			X
Bit 4	-	PLL N Div4		RW			X
Bit 3	-	PLL N Div3		RW			X
Bit 2	-	PLL N Div2		RW			X
Bit 1	-	PLL N Div1		RW			X
Bit 0	-	PLL N Div0		RW			X

SMBus Table: PLL Spread Spectrum Control Register

Byte 12	Pin #	Name	Control Function	Type	0	1	PWD
Bit 7	-	PLL SSP7	Spread Spectrum Programming bit(7:0)	RW	These Spread Spectrum bits in Byte 13 and 14 will program the spread percentage of PLL		X
Bit 6	-	PLL SSP6		RW			X
Bit 5	-	PLL SSP5		RW			X
Bit 4	-	PLL SSP4		RW			X
Bit 3	-	PLL SSP3		RW			X
Bit 2	-	PLL SSP2		RW			X
Bit 1	-	PLL SSP1		RW			X
Bit 0	-	PLL SSP0		RW			X

SMBus Table: PLL Spread Spectrum Control Register

Byte 13	Pin #	Name	Control Function	Type	0	1	PWD
Bit 7	-	Reserved					0
Bit 6	-	PLL SSP14	Spread Spectrum Programming bit(14:8)	RW	These Spread Spectrum bits in Byte 13 and 14 will program the spread percentage of PLL		X
Bit 5	-	PLL SSP13		RW			X
Bit 4	-	PLL SSP12		RW			X
Bit 3	-	PLL SSP11		RW			X
Bit 2	-	PLL SSP10		RW			X
Bit 1	-	PLL SSP9		RW			X
Bit 0	-	PLL SSP8		RW			X

SMBus Table: Reserved Test Register

Byte 14	Pin #	Name	Control Function	Type	0	1	PWD
Bit 7	-	Reserved Test Register. Do not write to this register, erratic device operation may occur.					1
Bit 6	-						0
Bit 5	-						0
Bit 4	-						0
Bit 3	-						0
Bit 2	-						0
Bit 1	-						0
Bit 0	-						0

DIF_STOP# - Assertion (transition from '1' to '0')

Asserting DIF_STOP# pin stops all DIF outputs that are set to be stoppable after their next transition. When the SMBus DIF_STOP tri-state bit corresponding to the DIF output of interest is programmed to a '0', DIF output will stop DIF_True = HIGH and DIF_Complement = LOW. When the SMBus DIF_STOP tri-state bit corresponding to the DIF output of interest is programmed to a '1', DIF outputs will be tri-stated.

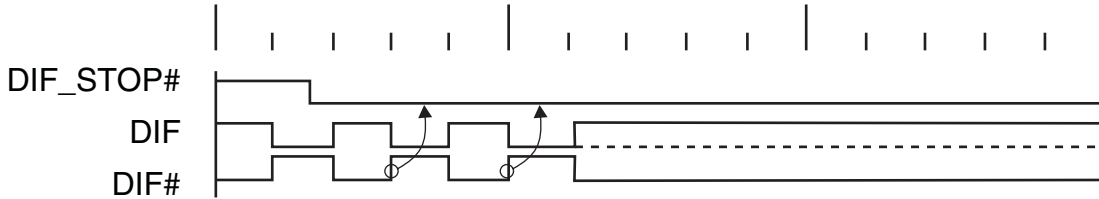

DIF_STOP# - De-assertion (transition from '0' to '1')

With the de-assertion of DIF_STOP# all stopped DIF outputs will resume without a glitch. The maximum latency from the de-assertion to active outputs is 2 - 6 DIF clock periods. If the control register tristate bit corresponding to the output of interest is programmed to '1', then the stopped DIF outputs will be driven High within 15nS of DIF_Stop# de-assertion to a voltage greater than 200mV.

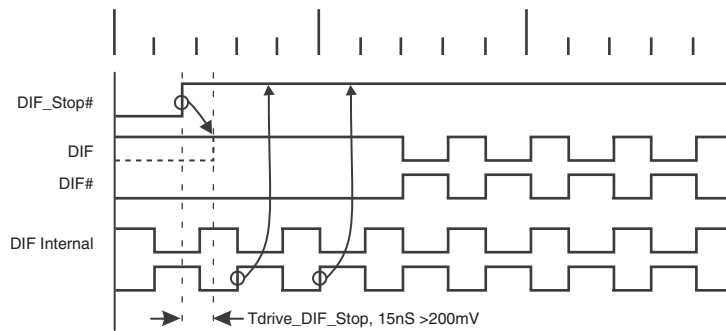

Absolute Max

Symbol	Parameter	Min	Max	Units
VDD_A	3.3V Core Supply Voltage		V _{DD} + 0.5V	V
VDD_In	3.3V Logic Input Supply Voltage	GND - 0.5	V _{DD} + 0.5V	V
Ts	Storage Temperature	-65	150	°C
Tambient	Ambient Operating Temp	0	70	°C
Tcase	Case Temperature		115	°C
ESD prot	Input ESD protection human body model	2000		V

Electrical Characteristics - Input/Supply/Common Output Parameters

T_A = 0 - 70°C; Supply Voltage V_{DD} = 3.3 V +/-5%

PARAMETER	SYMBOL	CONDITIONS	MIN	TYP	MAX	UNITS	NOTES
Input High Voltage	V _{IH}	3.3 V +/-5%	2		V _{DD} + 0.3	V	1
Input Low Voltage	V _{IL}	3.3 V +/-5%	V _{SS} - 0.3		0.8	V	1
Input High Current	I _{IH}	V _{IN} = V _{DD}	-5		5	uA	1
Input Low Current	I _{IL1}	V _{IN} = 0 V; Inputs with no pull-up resistors	-5			uA	1
	I _{IL2}	V _{IN} = 0 V; Inputs with pull-up resistors	-200			uA	1
Operating Supply Current	I _{DD3.3OP}	Full Active, C _L = Full load; f = 400 MHz		125	150	mA	1
		Full Active, C _L = Full load; f = 100 MHz		110	125	mA	1
	I _{DD3.3STOP}	All outputs stopped driven		106	120	mA	1
		All outputs stopped Hi-Z		48	60	mA	1
Input Frequency ³	F _i	V _{DD} = 3.3 V	14		25	MHz	3
Pin Inductance ¹	L _{pin}				7	nH	1
Input/Output Capacitance ¹	C _{IN}	Logic Inputs	1.5		5	pF	1
	C _{OUT}	Output pin capacitance			6	pF	1
Clk Stabilization ^{1,2}	T _{STAB}	From V _{DD} Power-Up and after input clock stabilization to 1st clock			1.8	ms	1,2
Modulation Frequency	f _{MOD}	Triangular Modulation	30		33	kHz	1
DIF output enable	t _{DIFOE}	DIF output enable after DIF_Stop# de-assertion			15	ns	1
Input Rise and Fall times	t _R /t _F	20% to 80% of VDD			5	ns	1

¹Guaranteed by design, not 100% tested in production.

²See timing diagrams for timing requirements.

³ Input frequency should be measured at the REFOUT pin and tuned to ideal 14.31818MHz or 25 MHz to meet

Electrical Characteristics - DIF 0.7V Current Mode Differential Pair

$T_A = 0 - 70^\circ\text{C}$; $V_{DD} = 3.3\text{ V} \pm 5\%$; $C_L = 2\text{pF}$, $R_S = 33.2\Omega$, $R_P = 49.9\Omega$, $I_{REF} = 475\mu\text{A}$

PARAMETER	SYMBOL	CONDITIONS	MIN	TYP	MAX	UNITS	NOTES
Output Impedance	Z_o^1	$V_o = V_x$	3000			Ω	1
Voltage High	VHigh	Statistical measurement on single ended signal using oscilloscope math function.	660		850	mV	1
Voltage Low	VLow		-150		150		1
Max Voltage	Vovs	Measurement on single ended signal using absolute value.			1150	mV	1
Min Voltage	Vuds		-300				1
Crossing Voltage (abs)	Vcross(abs)		250		550	mV	1
Crossing Voltage (var)	d-Vcross	Crossing variation over all edges			140	mV	1
Long Accuracy	ppm	see Tperiod min-max values	-300		300	ppm	1,2,5
Average period	Tperiod	400MHz nominal	2.4993		2.5008	ns	2
		400MHz spread	2.4993		2.5133	ns	2,3
		333.33MHz nominal	2.9991		3.0009	ns	2
		333.33MHz spread	2.9991		3.016	ns	2,3
		266.66MHz nominal	3.7489		3.7511	ns	2
		266.66MHz spread	3.7489		3.77	ns	2,3
		200MHz nominal	4.9985		5.0015	ns	2
		200MHz spread	4.9985		5.0266	ns	2,3
		166.66MHz nominal	5.9982		6.0018	ns	2
		166.66MHz spread	5.9982		6.0320	ns	2,3
		133.33MHz nominal	7.4978		7.5023	ns	2
		133.33MHz spread	7.4978		5.4000	ns	2,3
		100.00MHz nominal	9.9970		10.0030	ns	2
		100.00MHz spread	9.9970		10.0533	ns	2,3
Absolute min period	$T_{ab\text{min}}$	400MHz nominal/spread	2.4143			ns	1,2
		333.33MHz nominal/spread	2.9141			ns	1,2
		266.66MHz nominal/spread	3.6639			ns	1,2
		200MHz nominal/spread	4.8735			ns	1,2
		166.66MHz nominal/spread	5.8732			ns	1,2
		133.33MHz nominal/spread	7.3728			ns	1,2
		100.00MHz nominal/spread	9.8720			ns	1,2
Rise Time	t_r	$V_{OL} = 0.175\text{V}$, $V_{OH} = 0.525\text{V}$	175		700	ps	1
Fall Time	t_f	$V_{OH} = 0.525\text{V}$, $V_{OL} = 0.175\text{V}$	175		700	ps	1
Rise Time Variation	d- t_r				125	ps	1
Fall Time Variation	d- t_f				125	ps	1
Duty Cycle	d_{t3}	Measured Differentially	45		55	%	1
Skew, output to output	t_{sk3}	$V_T = 50\%$			35	ps	4
Jitter, PCI-e SRC phase	$t_{j\text{PCI-ephase}14}$	22MHz/1.5MHz/1.5MHz/10ns, 14.31818 MHz REF Clock			42	ps	4
Jitter, PCI-e SRC phase	$t_{j\text{PCI-ephase}25}$	22MHz/1.5MHz/1.5MHz/10ns, 25 MHz REF Clock			39	ps	4
Jitter, Cycle to cycle	$t_{j\text{cyc-cyc}}$	Measured Differentially			50	ps	1

¹Guaranteed by design and characterization, not 100% tested in production.

²All Long Term Accuracy and Clock Period specifications are guaranteed assuming that REFOUT is at 14.31818MHz or 25 MHz

³ Figures are for down spread.

⁴ This figure is the peak-to-peak phase jitter as defined by PCI-SIG for a PCI Express reference clock. Please visit <http://www.pcisig.com> for additional details

⁵ +/- 150 ppm for 100 MHz outputs

Electrical Characteristics - REF-14.318/25 MHz

$T_A = 0 - 70^{\circ}\text{C}$; $V_{DD} = 3.3\text{ V} \pm 5\%$; $C_L = 30\text{ pF}$ (unless otherwise specified)

PARAMETER	SYMBOL	CONDITIONS	MIN	TYP	MAX	UNITS	Notes
Long Accuracy	ppm	see Tperiod min-max values	-300	0	300	ppm	1
Clock period	T_{period}	14.318MHz output nominal	69.8270	69.8413	69.8550	ns	1
		25.000MHz output nominal	39.9880	40.0000	40.0120	ns	1
Output High Voltage	V_{OH}	$I_{OH} = -1\text{ mA}$	2.4			V	1
Output Low Voltage	V_{OL}	$I_{OL} = 1\text{ mA}$			0.4	V	1
Output High Current	I_{OH}	$V_{OH} @\text{MIN} = 1.0\text{ V}$, $V_{OH} @\text{MAX} = 3.135\text{ V}$	-29		-23	mA	1
Output Low Current	I_{OL}	$V_{OL} @\text{MIN} = 1.95\text{ V}$, $V_{OL} @\text{MAX} = 0.4\text{ V}$	29		27	mA	1
Rise Time	t_{r1}	$V_{OL} = 0.4\text{ V}$, $V_{OH} = 2.4\text{ V}$	1	1.6	2	ns	1
Fall Time	t_{f1}	$V_{OH} = 2.4\text{ V}$, $V_{OL} = 0.4\text{ V}$	1	1.6	2	ns	1,2
Duty Cycle	d_{t1}	$V_T = 1.5\text{ V}$	45	52.5	55	%	1,2
Jitter	$t_{\text{jyc-cyc}}$	$V_T = 1.5\text{ V}$		150	200	ps	1

¹Guaranteed by design and characterization, not 100% tested in production.

²All Long Term Accuracy and Clock Period specifications are guaranteed assuming that REFOUT is at 14.31818MHz or 25 MHz

Electrical Characteristics - Phase Jitter (Applies to: Revision D Devices, Revision ID = 3)

PARAMETER	SYMBOL	CONDITIONS	MIN	TYP	MAX	UNITS	Notes
Jitter, Phase	$t_{\text{jphasePLL}}$	PCIe Gen 1 specs (1.5 - 22 MHz)		40	108	ps	1,2
		FBD specs (11-33 MHz)			3	ps rms	1
		PCIe Gen 2 specs (5-16 MHz, 8-16 MHz)		2.23	3.1	ps rms	1

Notes on Phase Jitter:

¹ Applicable to all DIF outputs. See <http://www.pcisig.com> for complete specs. Guaranteed by design and characterization, not tested in production.

² Specification applies to revision C devices and later.

DIF Reference Clock			
Common Recommendations for Differential Routing	Dimension or Value	Unit	Figure
L1 length, Route as non-coupled 50 ohm trace.	0.5 max	inch	1
L2 length, Route as non-coupled 50 ohm trace.	0.2 max	inch	1
L3 length, Route as non-coupled 50 ohm trace.	0.2 max	inch	1
Rs	33	ohm	1
Rt	49.9	ohm	1

Down Device Differential Routing	Dimension or Value	Unit	Figure
L4 length, Route as coupled microstrip 100 ohm differential trace.	2 min to 16 max	inch	1
L4 length, Route as coupled stripline 100 ohm differential trace.	1.8 min to 14.4 max	inch	1

Differential Routing to PCI Express Connector	Dimension or Value	Unit	Figure
L4 length, Route as coupled microstrip 100 ohm differential trace.	0.25 to 14 max	inch	2
L4 length, Route as coupled stripline 100 ohm differential trace.	0.225 min to 12.6 max	inch	2

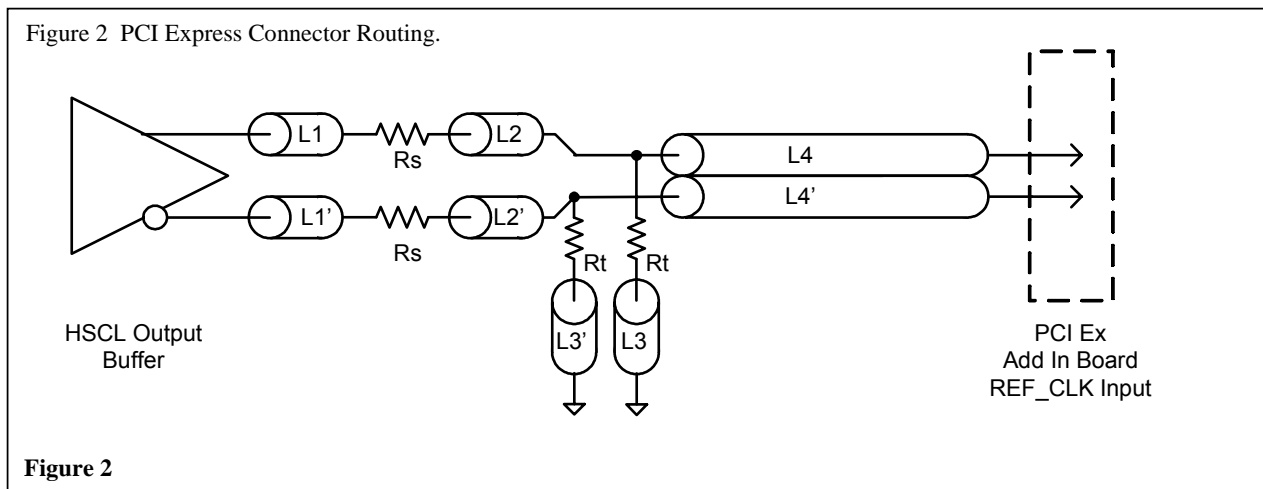
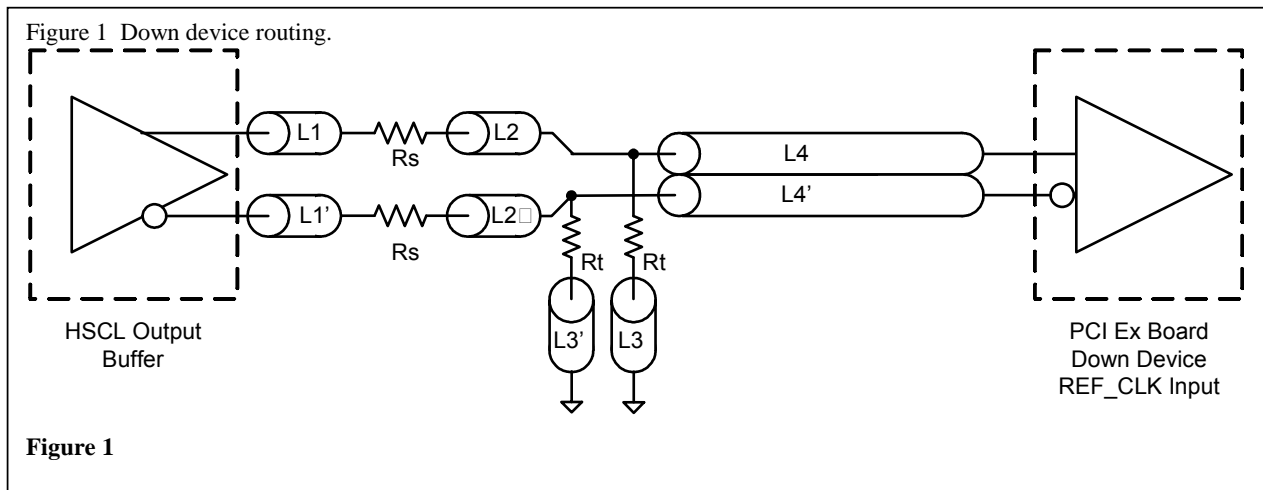

Alternative termination for LVDS and other common differential signals. Figure 3.

Vdiff	Vp-p	Vcm	R1	R2	R3	R4	Note
0.45 v	0.22v	1.08	33	150	100	100	
0.58	0.28	0.6	33	78.7	137	100	
0.80	0.40	0.6	33	78.7	none	100	ICS874003i-02 input compatible
0.60	0.3	1.2	33	174	140	100	Standard LVDS

R1a = R1b = R1

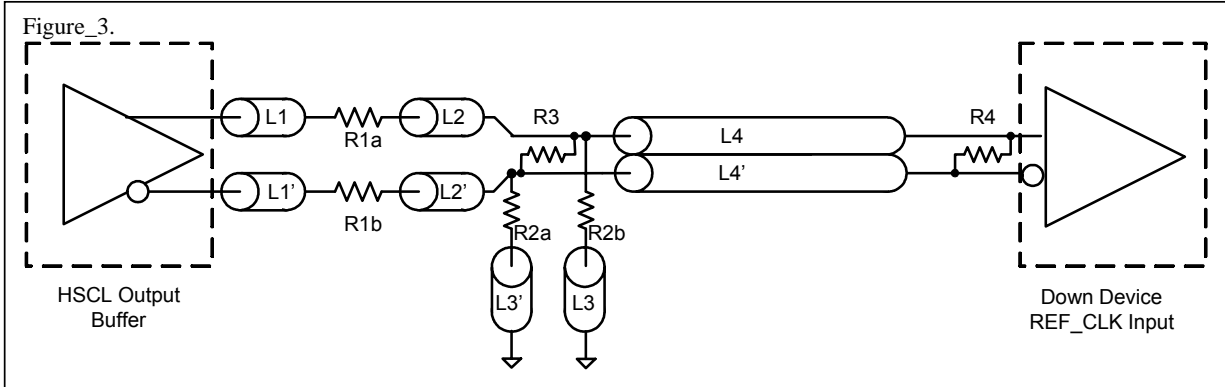

R2a = R2b = R2

Cable connected AC coupled application, figure 4

Component	Value	Note
R5a,R5b	8.2K 5%	
R6a,R6b	1K 5%	
Cc	0.1 uF	
Vcm	0.350 volts	

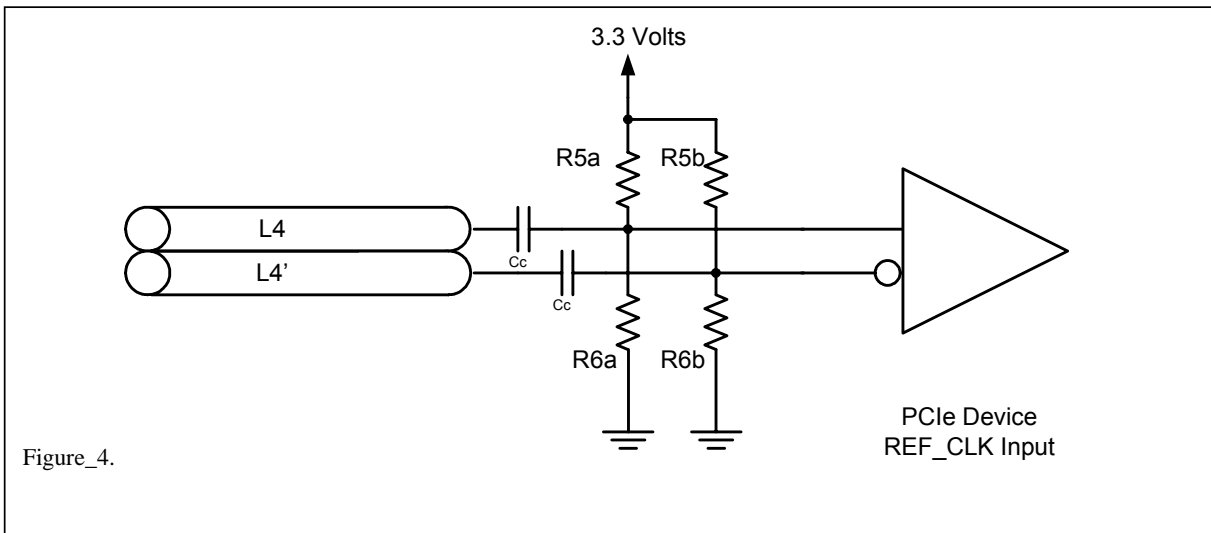

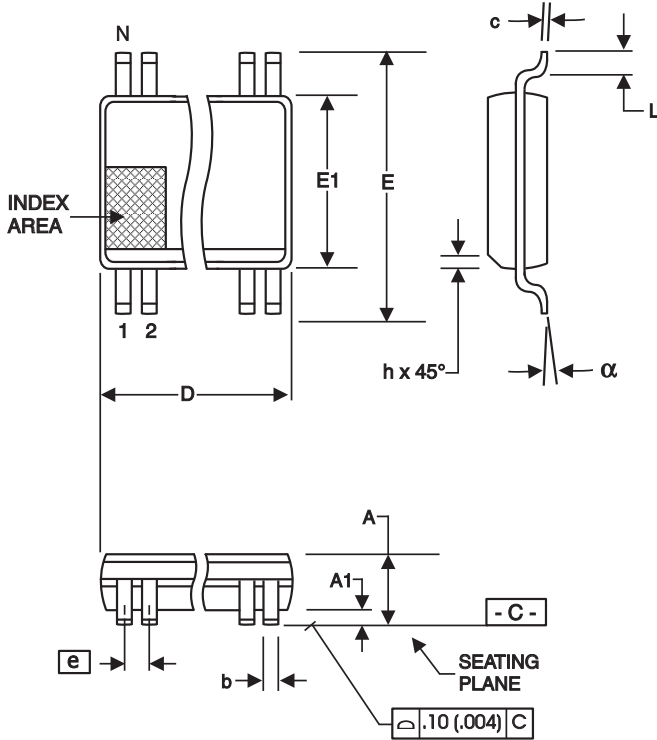

209 mil SSOP

SYMBOL	In Millimeters COMMON DIMENSIONS		In Inches COMMON DIMENSIONS	
	MIN	MAX	MIN	MAX
A	--	2.00	--	.079
A1	0.05	--	.002	--
A2	1.65	1.85	.065	.073
b	0.22	0.38	.009	.015
c	0.09	0.25	.0035	.010
D	SEE VARIATIONS		SEE VARIATIONS	
E	7.40	8.20	.291	.323
E1	5.00	5.60	.197	.220
e	0.65 BASIC		0.0256 BASIC	
L	0.55	0.95	.022	.037
N	SEE VARIATIONS		SEE VARIATIONS	
α	0°	8°	0°	8°

VARIATIONS

N	D mm.		D (inch)	
	MIN	MAX	MIN	MAX
28	9.90	10.50	.390	.413

Reference Doc.: JEDEC Publication 95, MO-150

10-0033

Ordering Information

ICS9FG104yFLFT

Example:

ICS XXXX y F - LFT

- Designation for tape and reel packaging
- RoHS Compliant (Optional)
- Package Type
F = SSOP
- Revision Designator (will not correlate with datasheet revision)
- Device Type (consists of 3 to 7 digit numbers)
- Prefix
ICS

4.40 mm. Body, 0.65 mm. Pitch TSSOP
(173 mil) (25.6 mil)

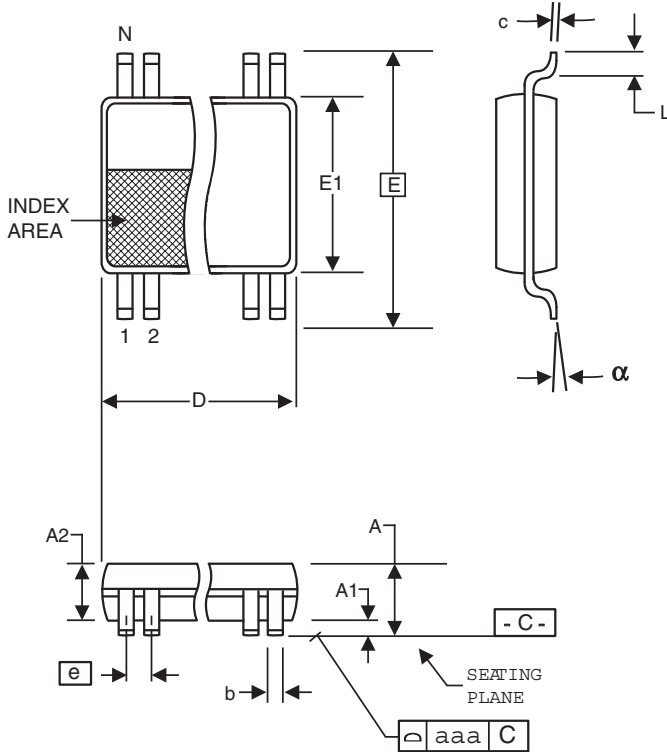

SYMBOL	In Millimeters COMMON DIMENSIONS		In Inches COMMON DIMENSIONS	
	MIN	MAX	MIN	MAX
A	--	1.20	--	.047
A1	0.05	0.15	.002	.006
A2	0.80	1.05	.032	.041
b	0.19	0.30	.007	.012
c	0.09	0.20	.0035	.008
D	SEE VARIATIONS		SEE VARIATIONS	
E	6.40 BASIC		0.252 BASIC	
E1	4.30	4.50	.169	.177
e	0.65 BASIC		0.0256 BASIC	
L	0.45	0.75	.018	.030
N	SEE VARIATIONS		SEE VARIATIONS	
α	0°	8°	0°	8°
aaa	--	0.10	--	.004

VARIATIONS

N	D mm.		D (inch)	
	MIN	MAX	MIN	MAX
28	9.60	9.80	.378	.386

Reference Doc.: JEDEC Publication 95, MO-153

10-0035

Ordering Information

ICS9FG104yGLFT

Example:

ICS XXXX y G - LFT

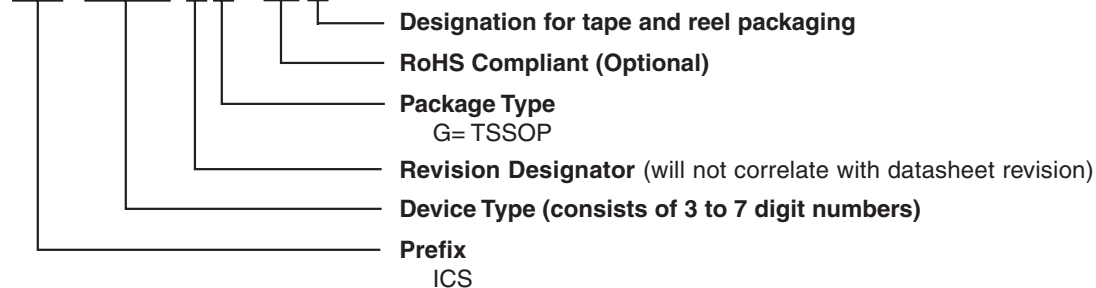

Revision History

Rev.	Issue Date	Description	Page #
D	6/2/2005	1. Updated SMBus Byte 3 bit 7, 5, 4 and 3. 2. Updated LF Ordering Information to RoHS Compliant.	9, 13-14
E	1/13/2006	Corrected Pin-Type for Pins 5 and 7.	2
F	4/13/2006	Added +/- 150 ppm accuracy spec for 100 MHz outputs.	1, 5
G	6/5/2006	Updated SSOP Comon Dimensions Table.	13
H	12/12/2006	Updated pinout to reflect internal pull up and pull down resistors.	1
I	1/2/2007	Fixed Typos on Pin Description.	2
J	4/2/2007	Added Phase Jitter Table.	12
K	4/12/2007	Added TSSOP Ordering Information.	16

Innovate with IDT and accelerate your future networks. Contact:

www.IDT.com

For Sales

800-345-7015
408-284-8200
Fax: 408-284-2775

For Tech Support

408-284-6578
pcclockhelp@idt.com

Corporate Headquarters

Integrated Device Technology, Inc.
6024 Silver Creek Valley Road
San Jose, CA 95138
United States
800 345 7015
+408 284 8200 (outside U.S.)

Asia Pacific and Japan

Integrated Device Technology
Singapore (1997) Pte. Ltd.
Reg. No. 199707558G
435 Orchard Road
#20-03 Wisma Atria
Singapore 238877
+65 6 887 5505

Europe

IDT Europe, Limited
Prime House
Barnett Wood Lane
Leatherhead, Surrey
United Kingdom KT22 7DE
+44 1372 363 339



www.IDT.com

© 2006 Integrated Device Technology, Inc. All rights reserved. Product specifications subject to change without notice. IDT and the IDT logo are trademarks of Integrated Device Technology, Inc. Accelerated Thinking is a service mark of Integrated Device Technology, Inc. All other brands, product names and marks are or may be trademarks or registered trademarks used to identify products or services of their respective owners.
Printed in USA