

Universal Single-Chip Clock Solution for VIA P4M266/KM266 DDR Systems

Features

- Supports VIA™ P4M266/KM266 chipsets
- Supports Pentium® 4, Athlon™ processors
- Supports two DDR DIMMS
- Supports three SDRAM DIMMS at 100 MHz
- Provides:
 - Two different programmable CPU clock pairs
 - Six differential SDRAM DDR pairs
 - Three low-skew/low-jitter AGP clocks
 - Seven low-skew/low-jitter PCI clocks
 - One 48M output for USB
 - One programmable 24M or 48M for SIO
- Dial-a-Frequency™ and Dial-a-dB™ features
- Spread Spectrum for best electromagnetic interference (EMI) reduction
- Watchdog feature for systems recovery
- SMBus-compatible for programmability
- 56-pin SSOP and TSSOP packages

Table 1. Frequency Selection Table

FS(3:0)	CPU	AGP	PCI
0000	66.80	66.80	33.40
0001	100.00	66.80	33.40
0010	120.00	60.00	30.00
0011	133.33	66.67	33.33
0100	72.00	72.00	36.00
0101	105.00	70.00	35.00
0110	160.00	64.00	32.00
0111	140.00	70.00	35.00
1000	77.00	77.00	38.50
1001	110.00	73.33	36.67
1010	180.00	60.00	30.00
1011	150.00	60.00	30.00
1100	90.00	60.00	30.00
1101	100.00	66.67	33.33
1100	200.00	66.67	33.33
1111	133.33	66.67	33.33

Block Diagram

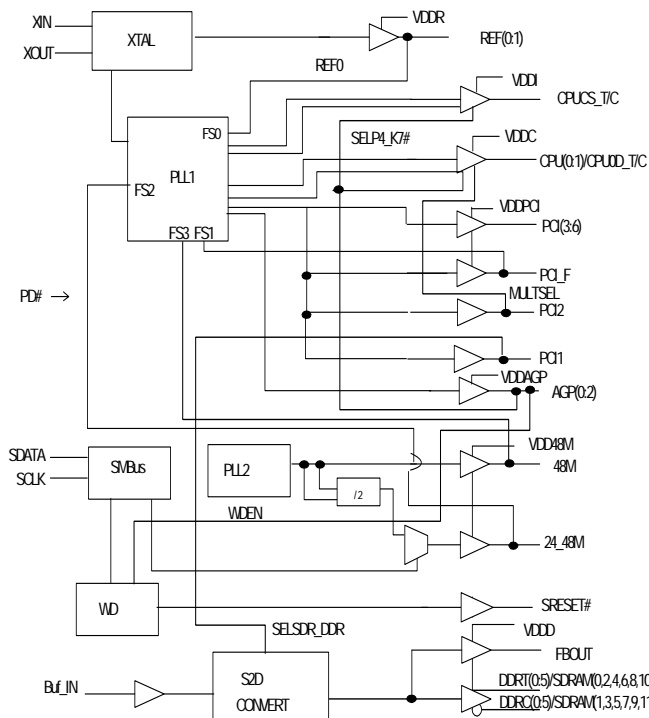

Pin Configuration^{L1}

*FS0/REF0	1	56	VTPWRGD#/REF1
VSSR	2	55	VDDR
XIN	3	54	VSSC
XOUT	4	53	CPUC/CPUOD_T
VDDAGP	5	52	CPUC/CPUOD_C
AGP0	6	51	VDDC
*SELP4_K7/AGP1	7	50	VDDI
AGP2	8	49	CPUCS_C
VSSAGP	9	48	CPUCS_T
**FS1/PCLF	10	47	VSSI
**SELSDR_DDR/PCI1	11	46	FBOUT
*MULTSEL/PCI2	12	45	BUF_IN
VSSPCI	13	44	DDRT0/SDRAM0
PCI3	14	43	DDRC0/SDRAM1
PCI4	15	42	DDRT1/SDRAM2
VDDPCI	16	41	DDRC1/SDRAM3
PCI5	17	40	VDDD
PCI6	18	39	VSSD
VSS48M	19	38	DDRT2/SDRAM4
**FS3/48M	20	37	DDRC2/SDRAM5
**FS2/24_48M	21	36	DDRT3/SDRAM6
VDD48M	22	35	DDRC3/SDRAM7
VDD	23	34	VDDD
VSS	24	33	VSSD
IREF	25	32	DDRT4/SDRAM8
*PD#/SRESET#	26	31	DDRC4/SDRAM9
SCLK	27	30	DDRT5/SDRAM10
SDATA	28	29	DDRC5/SDRAM11

CY28341

56 pin SSOP

Note:

1. Pins marked with [*] have internal pull-up resistors. Pins marked with [**] have internal pull-down resistors.

Pin Description^[2]

Pin	Name	PWR	I/O	Description
3	XIN		I	Oscillator Buffer Input. Connect to a crystal or to an external clock.
4	XOUT	VDD	O	Oscillator Buffer Output. Connect to a crystal. Do not connect when an external clock is applied at X _{IN} .
1	FS0/REF0	VDD	I/O PU	Power-on Bidirectional Input/Output. At power-up, FS0 is the input. When the power supply voltage crosses the input threshold voltage, FS0 state is latched and this pin becomes REF0, buffered copy of signal applied at XIN.
56	VTT_PWRGD#	VDDR	I	If SELP4_K7 = 1, with a P4 processor setup as CPUT/C. At power-up, VTT_PWRGD# is an input. When this input transitions to a logic LOW, the FS (3:0) and MULTSEL are latched and all output clocks are enabled. After the first HIGH to LOW transition on VTT_PWRGD#, this pin is ignored and will not effect the behavior of the device thereafter. When the VTT_PWRGD# feature is not used, please connect this signal to ground through a 10KΩ resistor.
	REF1	VDDR	O	If SELP4_K7 = 0, with an Athlon (K7) processor as CPU_OD(T:C). VTT_PWRGD# function is disabled, and the feature is ignored. This pin becomes REF1 and is a buffered copy of the signal applied at X _{IN} .
44,42,38, 36,32,30	DDRT (0:5)/SDRAM(0,2,4,6, 8,10)	VDDD	O	These pins are programmable through strapping pin11, SELSDR_DDR#.If SELSDR_DDR#.= 0, these pins are configured for DDR clock outputs. They are "True" copies of signal applied at Pin45, BUF_IN. In this mode, VDDD must be 2.5VIf SelSDR_DDR#.= 1, these pins are configured for SDRAM(0,2,4,6,8,10) single ended clock outputs, copies of (and in phase with) signal applied at Pin45, BUF_IN. In this mode, VDDD must be 3.3V
43,41,37 35,31,29	DDRC (0:5)/SDRAM(1,3,5,7, 9,11)	VDDD	O	These pins are programmable through strapping pin11, SELSDR_DDR#.If SelSDR_DDR#.= 0, these pins are configured for DDR clock outputs. They are "Complementary" copies of signal applied at Pin45, BUF_IN. In this mode, VDDD must be 2.5VIf SelSDR_DDR#.= 1, these pins are configured for SDRAM(1,3,5,7,9,11) single-ended clock outputs, copies of (and in phase with) signal applied at Pin45, BUF_IN. In this mode, VDDD must be 3.3V.
7	SELP4_K7 / AGP1	VDDAG P	I/O PU	Power-on Bidirectional Input/Output. At power-up, SELP4_K7 is the input. When the power supply voltage crosses the input threshold voltage, SELP4_K7 state is latched and this pin becomes AGP1 clock output. SELP4_K7 = 1, P4 mode. SELP4_K7 = 0, K7 mode.
12	MULTSEL / PCI2	VDDPCI	I/O PU	Power-on Bidirectional Input/Output. At power-up, MULTSEL is the input. When the power supply voltage crosses the input threshold voltage, MULTSEL state is latched and this pin becomes PCI2 clock output. MULTSEL = 0, loh is 4 x IREFMULTSEL = 1, loh is 6 x IREF.
53	CPUT/CPUOD_T	VDDC	O	3.3V CPU Clock outputs. This pin is programmable through strapping pin7, SELP4_K7. If SELP4_K7 = 1, this pin is configured as the CPUT Clock Output. If SELP4_K7 = 0, this pin is configured as the CPUOD_T Open Drain Clock Output. See <i>Table 1</i> .
52	CPUC/CPUOD_C	VDDC	O	3.3V CPU Clock outputs. This pin is programmable through strapping pin7, SELP4_K7. If SELP4_K7 = 1, this pin is configured as the CPUC Clock Output. If SELP4_K7 = 0, this pin is configured as the CPUOD_C Open Drain Clock Output. See <i>Table 1</i> .
48,49	CPUCS_T/C	VDDI	O	2.5V CPU Clock Outputs for Chipset. See <i>Table 1</i> .
14,15,17, 18	PCI (3:6)	VDDPCI	O	PCI Clock Outputs. Are synchronous to CPU clocks. See <i>Table 1</i> .
10	FS1/PCI_F	VDDPCI	I/O PD	Power-on Bidirectional Input/Output. At power-up, FS0 is the input. When the power supply voltage crosses the input threshold voltage, FS1 state is latched and this pin becomes PCI_F clock output.
20	FS3/48M	VDD48M	I/O PD	Power-on Bidirectional Input/Output. At power-up, FS3 is the input. When the power supply voltage crosses the input threshold voltage, FS3 state is latched and this pin becomes 48M, a USB clock output.

Pin Description^[2] (continued)

Pin	Name	PWR	I/O	Description
11	SELSDR_DDR#/PCI1	VDDPCI	I/O PD	Power-on Bidirectional Input/Output. At power-up, SELSDR_DDR is the input. When the power supply voltage crosses the input threshold voltage, SELSDR_DDR state is latched and this pin becomes PCI clock output. SelSDR_DDR#. = 0, DDR Mode. SelSDR_DDR#. = 1, SDR Mode.
21	FS2/24_48M	VDD48M	I/O PD	Power-on Bidirectional Input/Output. At power-up, FS2 is the input. When the power supply voltage crosses the input threshold voltage, FS2 state is latched and this pin becomes 24_48M, a SIO programmable clock output.
6	AGP0	VDDAGP	O	AGP Clock Output. Is synchronous to CPU clocks. See <i>Table 1</i> .
8	AGP2	VDDAGP	O	AGP Clock Output. Is synchronous to CPU clocks. See <i>Table 1</i> .
25	IREF		I	Current reference programming input for CPU buffers. A precise resistor is attached to this pin, which is connected to the internal current reference.
28	SDATA		I/O	Serial Data Input. Conforms to the Philips I2C specification of a Slave Receive/Transmit device. It is an input when receiving data. It is an open drain output when acknowledging or transmitting data.
27	SCLK		I	Serial Clock Input. Conforms to the Philips I2C specification.
26	PD#/SRESET#		I/O PU	Power-down Input/System Reset Control Output. If Byte6 Bit7 = 0, this pin becomes a SRESET# open drain output, and the internal pulled up is not active. See system reset description. If Byte6 Bit7 = 1 (default), this pin becomes PD# input with an internal pull-up. When PD# is asserted LOW, the device enters power-down mode. See power management function.
45	BUF_IN			If SelSDR_DDR#. = 0, 2.5V CMOS type input to the DDR differential buffers. If SelSDR_DDR#. = 1, 3.3V CMOS type input to the SDR buffer.
46	FBOUT			If SelSDR_DDR#. = 0, 2.5V single ended SDRAM buffered output of the signal applied at BUF_IN. It is in phase with the DDRT(0:5) signals. If SelSDR_DDR#. = 1, 3.3V single ended SDRAM buffered output of the signal applied at BUF_IN. It is in phase with the SDRAM(0:11) signals
5	VDDAGP			3.3V Power Supply for AGP clocks
51	VDDC			3.3V Power Supply for CPUT/C clocks
16	VDDPCI			3.3V Power Supply for PCI clocks
55	VDDR			3.3V Power Supply for REF clock
50	VDDI			2.5V Power Supply for CPUCS_T/C clocks
22	VDD48M			3.3V Power Supply for 48M
23	VDD			3.3V Common Power Supply
34,40	VDDD			If SelSDR_DDR#. = 0, 2.5V Power Supply for DDR clocks. If SelSDR_DDR#. = 1, 3.3V Power Supply for SDR clocks.
9	VSSAGP			Ground for AGP clocks
13	VSSPCI			Ground for PCI clocks
54	VSSC			Ground for CPUT/C clocks
33,39	VSSD			Ground for DDR clocks
19	VSS48M			Ground for 48M clock
47	VSSI			Ground for ICPUCS_T/C clocks
24	VSS			Common Ground

Note:

2. PU = internal Pull-up. PD = internal Pull-down. Typically = 250 kW (range 200 kW to 500 kW).

Serial Data Interface

To enhance the flexibility and function of the clock synthesizer, a two-signal serial interface is provided. Through the Serial Data Interface, various device functions such as individual clock output buffers, etc., can be individually enabled or disabled.

The registers associated with the Serial Data Interface initialize to their default setting upon power-up, and therefore use of this interface is optional. Clock device register changes are normally made upon system initialization, if any are required. The interface can also be used during system operation for power management functions.

Data Protocol

The clock driver serial protocol accepts Byte Write, Byte Read, Block Write, and Block Read operation from the controller. For Block Write/Read operation, the bytes must be accessed in sequential order from lowest to highest byte (most significant bit first) with the ability to stop after any complete byte has been transferred. For Byte Write and Byte Read operations, the system controller can access individual indexed bytes. The offset of the indexed byte is encoded in the command code, as described in *Table 2*.

The Block Write and Block Read protocol is outlined in *Table 3*, while *Table 4* outlines the corresponding Byte Write and Byte Read protocol. The slave receiver address is 11010010 (D2h).

Table 2. Command Code Definition

Bit	Description
7	0 = Block Read or Block Write operation 1 = Byte Read or Byte Write operation
(6:0)	Byte offset for Byte Read or Byte Write operation. For Block Read or Block Write operations, these bits should be "0000000"

Table 3. Block Read and Block Write Protocol

Block Write Protocol		Block Read Protocol	
Bit	Description	Bit	Description
1	Start	1	Start
2:8	Slave address – 7 bits	2:8	Slave address – 7 bits
9	Write	9	Write
10	Acknowledge from slave	10	Acknowledge from slave
11:18	Command Code – 8-bit "00000000" stands for Block operation	11:18	Command Code – 8-bit "00000000" stands for Block operation
19	Acknowledge from slave	19	Acknowledge from slave
20:27	Byte Count – 8 bits	20	Repeat start
28	Acknowledge from slave	21:27	Slave address – 7 bits
29:36	Data byte 0 – 8 bits	28	Read
37	Acknowledge from slave	29	Acknowledge from slave
38:45	Data byte 1 – 8 bits	30:37	Byte count from slave – 8 bits
46	Acknowledge from slave	38	Acknowledge
....	Data Byte N/Slave acknowledge...	39:46	Data byte from slave – 8 bits
....	Data Byte N – 8 bits	47	Acknowledge
....	Acknowledge from slave	48:55	Data byte from slave – 8 bits
....	Stop	56	Acknowledge
		Data bytes from slave/Acknowledge
		Data byte N from slave – 8 bits
		Not Acknowledge
		Stop

Table 4. Byte Read and Byte Write Protocol

Byte Write Protocol		Byte Read Protocol	
Bit	Description	Bit	Description
1	Start	1	Start
2:8	Slave address – 7 bits	2:8	Slave address – 7 bits
9	Write	9	Write
10	Acknowledge from slave	10	Acknowledge from slave
11:18	Command Code – 8 bits “1xxxxxx” stands for byte operation bit[6:0] of the command code represents the offset of the byte to be accessed	11:18	Command Code – 8 bits “1xxxxxx” stands for byte operation bit[6:0] of the command code represents the offset of the byte to be accessed
19	Acknowledge from slave	19	Acknowledge from slave
20:27	Byte Count – 8 bits	20	Repeat start
28	Acknowledge from slave	21:27	Slave address – 7 bits
29	Stop	28	Read
		29	Acknowledge from slave
		30:37	Data byte from slave – 8 bits
		38	Not Acknowledge
		39	Stop

Serial Control Registers

Byte 0: Frequency Select Register

Bit	@Pup	Pin#	Name	Description
7	0		Reserved	Reserved
6	H/W Setting	21	FS2	For Selecting Frequencies see <i>Table 1</i> .
5	H/W Setting	10	FS1	For Selecting Frequencies see <i>Table 1</i> .
4	H/W Setting	1	FS0	For Selecting Frequencies see <i>Table 1</i> .
3	0			If this bit is programmed to “1,” it enables Write to bits (6:4,1) for selecting the frequency via software (SMBus). If this bit is programmed to a “0,” it enables only Read of bits (6:4,1), which reflects the hardware setting of FS(0:3).
2	H/W Setting	11	SELSDR_DDR	Only for reading the hardware setting of the SDRAM interface mode, status of SELSDR_DDR# strapping.
1	H/W Setting	20	FS3	For Selecting frequencies see <i>Table 1</i> .
0	H/W Setting	7	SELP4_K7	Only for reading the hardware setting of the CPU interface mode, status of SELP4_K7# strapping.

Byte 1: CPU Clocks Register

Bit	@Pup	Pin#	Name	Description
7	0		MODE	0 = Down Spread. 1 = Center Spread. See <i>Table 9</i> .
6	1		SSCG	1 = Enable (default). 0 = Disable
5	1		SST1	Select spread bandwidth. See <i>Table 9</i> .
4	1		SST0	Select spread bandwidth. See <i>Table 9</i> .
3	1	48,49	CPUCS_T, CPUCS_C	1 = output enabled (running). 0 = output disabled asynchronously in a LOW state.
2	1	53,52	CPUT/CPUOD_T CPUC/CPUOD_C	1 = output enabled (running). 0 = output disable.

Byte 1: CPU Clocks Register (continued)

1	1	53,52	CPUT/C	In K7 mode, this bit is ignored. In P4 mode, 0 = when PD# asserted LOW, CPUT stops in a HIGH state, CPUC stops in a LOW state. In P4 mode, 1 = when PD# asserted LOW, CPUT and CPUC stop in High-Z.
0	1	11	MULT0	Only For reading the hardware setting of the Pin11 MULT0 value.

Byte 2: PCI Clock Register

Bit	@Pup	Pin#	Name	Description
7	0		PCI_DRV	PCI clock output drive strength 0 = Normal, 1 = increase the drive strength 20%.
6	1	10	PCI_F	1 = output enabled (running). 0 = output disabled asynchronously in a LOW state.
5	1	18	PCI6	1 = output enabled (running). 0 = output disabled asynchronously in a LOW state.
4	1	17	PCI5	1 = output enabled (running). 0 = output disabled asynchronously in a LOW state.
3	1	15	PCI4	1 = output enabled (running). 0 = output disabled asynchronously in a LOW state.
2	1	14	PCI3	1 = output enabled (running). 0 = output disabled asynchronously in a LOW state.
1	1	12	PCI2	1 = output enabled (running). 0 = output disabled asynchronously in a LOW state.
0	1	11	PCI1	1 = output enabled (running). 0 = output disabled asynchronously in a LOW state.

Byte 3: AGP/Peripheral Clocks Register

Bit	@Pup	Pin#	Name	Description
7	0	21	24_48M	"0" = pin21 output is 24MHz. Writing a "1" into this register asynchronously changes the frequency at pin21 to 48 MHz.
6	1	20	48MHz	1 = output enabled (running). 0 = output disabled asynchronously in a LOW state.
5	1	21	24_48M	1 = output enabled (running). 0 = output disabled asynchronously in a LOW state.
4	0	6,7,8	DASAG1	Programming these bits allow shifting skew of the AGP(0:2) signals relative to their default value. See <i>Table 5</i> .
3	0	6,7,8	DASAG0	
2	1	8	AGP2	1 = output enabled (running). 0 = output disabled asynchronously in a LOW state.
1	1	7	AGP1	1 = output enabled (running). 0 = output disabled asynchronously in a LOW state.
0	1	6	AGP0	1 = output enabled (running). 0 = output disabled asynchronously in a LOW state.

Table 5. Dial-a-Skew™ AGP(0:2)

DASAG (1:0)	AGP(0:2) Skew Shift
00	Default
01	-280 ps
10	+280 ps
11	+480 ps

Byte 4: Peripheral Clocks Register

Bit	@Pup	Pin#	Name	Description
7	1	20	48M	1 = normal strength, 0 = high strength 1 = normal strength, 0 = high strength
6	1	21	24_48M	1 = normal strength, 0 = high strength 1 = normal strength, 0 = high strength
5	0	6,7,8	DARAG1	Programming these bits allow modifying the frequency ratio of the AGP(2:0), PCI(6:1, F) clocks relative to the CPU clocks. See <i>Table 6</i> .
4	0	6,7,8	DARAG0	
3	1	1	REF0	1 = output enabled (running). 0 = output disabled asynchronously in a LOW state.
2	1	56	REF1	1 = output enabled (running). 0 = output disabled asynchronously in a LOW state. (K7 Mode only.)
1	1	1	REF0	1 = normal strength, 0 = high strength
0	1	56	REF1	1 = normal strength, 0 = high strength (K7 Mode only.)

Table 6. Dial-A-Ratio™ AGP(0:2)

DARAG (1:0)	CU/AGP Ratio
-------------	--------------

Table 6. Dial-A-Ratio™ AGP(0:2)

00	Frequency Selection Default
01	2/1
10	2.5/1
11	3/1

Byte 5: SDR/DDR Clock Register

Bit	@Pup	Pin#	Name	Description
7	0	45	BUF_IN threshold voltage	DDR Mode, BUF_IN threshold setting. 0 = 1.15V, 1 = 1.05VSDR Mode, BUF_IN threshold setting. 0 = 1.35V, 1 = 1.25V
6	1	46	FBOUT	1 = output enabled (running). 0 = output disabled asynchronously in a LOW state.
5	1	29,30	DDRT/C5/SD RAM(10,11)	1 = output enabled (running). 0 = output disabled asynchronously in a LOW state.
4	1	31,32	DDRT/C4/SD RAM(8,9)	1 = output enabled (running). 0 = output disabled asynchronously in a LOW state.
3	1	35,36	DDRT/C3/SD RAM(6,7)	1 = output enabled (running). 0 = output disabled asynchronously in a LOW state.
2	1	37,38	DDRT/C2/SD RAM(4,5)	1 = output enabled (running). 0 = output disabled asynchronously in a LOW state.
1	1	41,42	DDRT/C1/SD RAM(2,3)	1 = output enabled (running). 0 = output disabled asynchronously in a LOW state.
0	1	43,44	DDRT/C0/SD RAM(0,1)	1 = output enabled (running). 0 = output disabled asynchronously in a LOW state.

Byte 6: Watchdog Register

Bit	@Pup	Pin#	Name	Description
7	1	26	SRESET#	1 = Pin 26 is the input pin as PD# signal. 0 = Pin 26 is the output pin as SRESET# signal.
6	0		Frequency Revert	This bit allows setting the Revert Frequency once the system is rebooted due to Watchdog time out only. 0 = selects frequency of existing H/W setting 1 = selects frequency of the second to last S/W setting (the software setting prior to the one that caused a system reboot).
5	0		WDTEST	WD-Test, ALWAYS program to "0."
4	0		WD Alarm	This bit is set to "1" when the Watchdog times out. It is reset to "0" when the system clears the WD time stamps (WD3:0).
3	0		WD3	This bit allows the selection of the time stamp for the Watchdog timer. See <i>Table 7</i> .
2	0		WD2	This bit allows the selection of the time stamp for the Watchdog timer. See <i>Table 7</i> .
1	0		WD1	This bit allows the selection of the time stamp for the Watchdog timer. See <i>Table 7</i> .
0	0		WD0	This bit allows the selection of the time stamp for the Watchdog timer. See <i>Table 7</i> .

Table 7. Watchdog Time Stamp

WD3	WD2	WD1	WD0	FUNCTION
0	0	0	0	Off
0	0	0	1	1 second
0	0	1	0	2 seconds
0	0	1	1	3 seconds
0	1	0	0	4 seconds
0	1	0	1	5 seconds
0	1	1	0	6 seconds
0	1	1	1	7 seconds
1	0	0	0	8 seconds
1	0	0	1	9 seconds
1	0	1	0	10 seconds

Table 7. Watchdog Time Stamp

1	0	1	1	11 seconds
1	1	0	0	12 seconds
1	1	0	1	13 seconds
1	1	1	0	14 seconds
1	1	1	1	15 seconds

Byte 7: Dial-a-Frequency Control Register N

Bit	@Pup	Pin#	Name	Description
7	0		Reserved	Reserved for device function test.
6	0		N6, MSB	These bits are for programming the PLL's internal N register. This access allows the user to modify the CPU frequency at very high resolution (accuracy). All other synchronous clocks (clocks that are generated from the same PLL, such as PCI) remain at their existing ratios relative to the CPU clock.
5	0		N5	
4	0		N4	
3	0		N3	
2	0		N2	
1	0		N1	
0	0		N0, LSB	

Byte 8: Silicon Signature Register (All bits are Read-only)

Bit	@Pup	Pin#	Name	Description
7	0		Revision_ID3	Revision ID bit [3]
6	0		Revision_ID2	Revision ID bit [2]
5	0		Revision_ID1	Revision ID bit [1]
4	0		Revision_ID0	Revision ID bit [0]
3	1		Vender_ID3	Cypress Vender ID bit [3].
2	0		Vender_ID2	Cypress Vender ID bit [2].
1	0		Vender_ID1	Cypress Vender ID bit [1].
0	0		Vender_ID0	Cypress Vender ID bit [0].

Byte9: Dial-A-Frequency Control Register R

Bit	@Pup	Pin#	Name	Description
7	0			Reserved
6	0		R5, MSB	These bits are for programming the PLL's internal R register. This access allows the user to modify the CPU frequency at very high resolution (accuracy). All other synchronous clocks (clocks that are generated from the same PLL, such as PCI) remain at their existing ratios relative to the CPU clock.
5	0		R4	
4	0		R3	
3	0		R2	
2	0		R1	
1	0		R0	
0	0		DAF_ENB	This Edge-trigger bit enables the Dial-a-Frequency N and R bits. It is the transition of this bit from "0" to "1" that latches the N(6:0) and R(5:0) data into the internal N and R registers. The user must only program a one time "1" into this bit for every new N and R values

Dial-a-Frequency Feature

SMBus Dial-a-Frequency feature is available in this device via Byte7 and Byte9. P is a PLL constant that depends on the frequency selection prior to accessing the Dial-a-Frequency feature.

Table 8.

FS(4:0)	P
XXXXX	96016000

Spread Spectrum Clock Generation (SSCG)

Spread Spectrum is enabled/disabled via SMBus register Byte 1, Bit 7.

Table 9. Spread Spectrum Table

Mode	SST1	SST0	% Spread
0	0	0	-1.5%
0	0	1	-1.0%
0	1	0	-0.7%
0	1	1	-0.5%
1	0	0	±0.75%
1	0	1	±0.5%
1	1	0	±0.35%
1	1	1	±0.25%

Swing Select Functions Through Hardware

MULT-SEL	Board Target Trace/Term Z	Reference R, IREF = VDD/(3*Rr)	Output Current Iref	VOH@Z
0	50 Ohm	Rr = 221 1%, IREF = 5.00 mA	IOH = 4 * Iref	1.0V@50
1	50 Ohm	Rr = 475 1%, IREF = 2.32 mA	IOH = 6 * Iref	0.7V@50

System Self-recovery Clock Management

This feature is designed to allow the system designer to change frequency while the system is running and reboot the

operation of the system in case of a hang-up due to the frequency change.

When the system sends an SMBus command requesting a frequency change through Byte 4 or through Bytes 13 and 14, it must have previously sent a command to Byte 12, for selecting which time out stamp the Watchdog must perform, otherwise the System Self Recovery feature will not be applicable. Consequently, this device will change frequency and then the Watchdog timer starts timing. Meanwhile, the system BIOS is running its operation with the new frequency. If this device receives a new SMBus command to clear the bits originally programmed in Byte 12, Bits (3:0) (reprogram to 0000), before the Watchdog times out, then this device will keep operating in its normal condition with the new selected frequency. If the Watchdog times out the first time before the new SMBus reprograms Byte12, Bits (3:0) to (0000), then this device will send a low system reset pulse, on SRESET# (see Byte12, Bit7), and changes WD alarm (Byte12, Bit4) status to "1" then restarts the Watchdog timer again. If the Watchdog times out a second time, then this device will send another low pulse on SRESET#, will relatch original hardware strapping frequency (or second to last software selected frequency, see Byte12, Bit6) selection, set WD alarm bit (Byte12, Bit4) to "1," then start WD timer again. The above-described sequence will keep repeating until the BIOS clears the SMBus Byte12, Bits(3:0). Once the BIOS sets Byte12, Bits(3:0) = 0000, then the Watchdog timer is turned off and the WD alarm bit (Byte12, Bit4) is reset to "0."

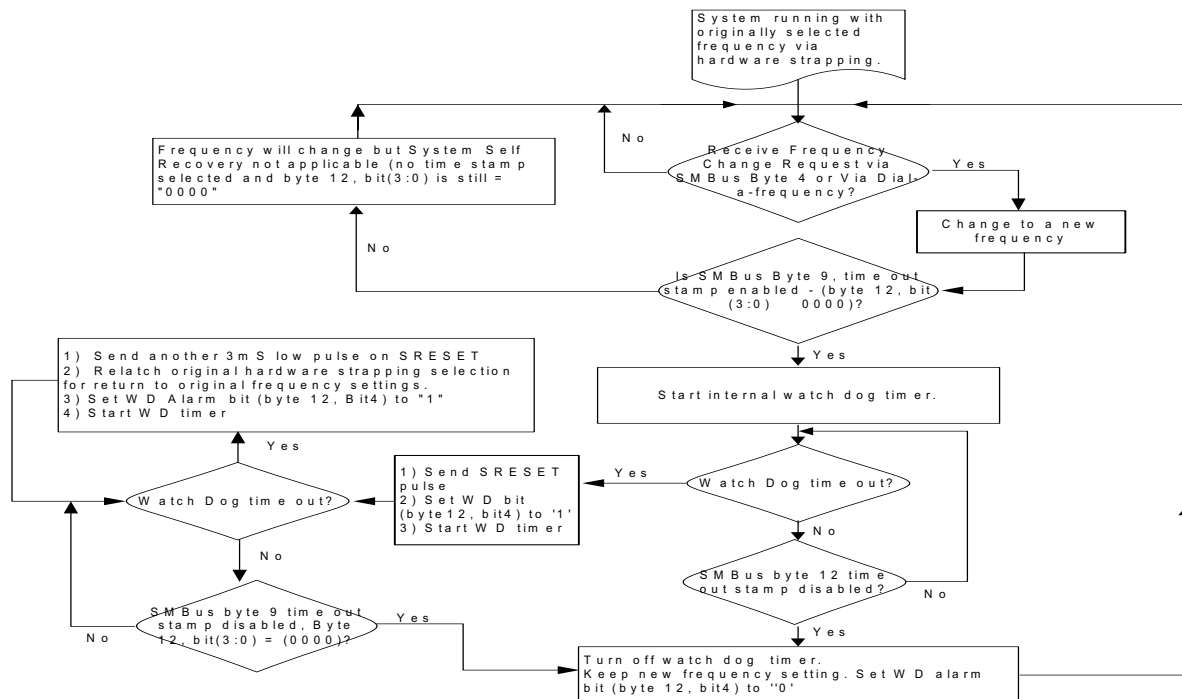
Figure 1.

Power Management Functions

All clocks can be individually enabled or stopped via the 2-wire control interface. All clocks are stopped in the LOW state. All clocks maintain a valid HIGH period on transitions from running to stop and on transitions from stopped to running

when the chip was not powered down. On power-up, the VCOs will stabilize to the correct pulse widths within about 0.5 mS.

Maximum Ratings^[3]

Input Voltage Relative to V_{SS} : $V_{SS} - 0.3V$
 Input Voltage Relative to V_{DDQ} or AV_{DD} : $V_{DD} + 0.3V$
 Storage Temperature: $-65^{\circ}C$ to $+150^{\circ}C$
 Operating Temperature: $0^{\circ}C$ to $+70^{\circ}C$
 Maximum ESD 2000V
 Maximum Power Supply: 5.5V

This device contains circuitry to protect inputs against damage due to high-static voltages or electric field. However, precautions should be take to avoid application of any voltage higher than the maximum-rated voltages to this circuit. For proper operation, V_{IN} and V_{OUT} should be constrained to the range:

$$V_{SS} < (V_{IN} \text{ or } V_{OUT}) < V_{DD}$$

Unused inputs must always be tied to an appropriate logic voltage level (either V_{SS} or V_{DD}).

DC Parameters $V_{DD} = V_{DDPCI} = V_{DDAGP} = V_{DDR} = V_{DD48M} = V_{DDC} = 3.3V \pm 5\%$, $V_{DDI} = V_{DD} = 2.5V \pm 5\%$, $T_A = 0^{\circ}C$ to $+70^{\circ}C$

Parameter	Description	Conditions	Min.	Typ.	Max.	Unit
VIL1	Input Low Voltage	Applicable to PD#, F S(0:4)			0.8	Vdc
VIH1	Input High Voltage		2.0			Vdc
VIL2	Input Low Voltage	Applicable to SDATA and SCLK			1.0	Vdc
VIH2	Input High Voltage		2.2			Vdc
Vol	Output Low Voltage for SRESET#	I_{OL}	0.4			V
Iol	Pull-down Current for SRESET#	$V_{OL} = 0.4V$	24	35		mA
Ioz	Three-state Leakage Current				10	μA
Idd3.3V	Dynamic Supply Current	CPU Frequency Set at 133.3 MHz ^[5]		150	190	mA
Idd2.5V	Dynamic Supply Current	CPU Frequency Set at 133.3 MHz ^[5]		175	195	mA
Ipd	Power-down Supply Current	PD# = 0		95	600	μA
Ipup	Internal Pull-up Device Current	Input @ V_{SS}			-25	μA
Ipdwn	Internal Pull-down Device Current	Input @ V_{DD}			10	μA
Cin	Input Pin Capacitance				5	pF
Cout	Output Pin Capacitance				6	pF
Lpin	Pin Inductance				7	pF
Cxtal	Crystal Pin Capacitance	Measured from the X_{IN} or X_{OUT} to V_{SS}	27	36	45	pF

AC Parameters

Parameter	Description	100 MHz		133MHz		200 MHz		Unit	Notes ^[4]
		Min.	Max.	Min.	Max	Min.	Max		
XTAL									
TDC	X_{IN} Duty Cycle	45	55	45	55	45	55	%	7,8
TPeriod	X_{IN} Period	69.841	71.0	69.84	71.0	69.84	71.0	ns	7,8
VHIGH	X_{IN} High Voltage	$0.7V_{DD}$	V_{DD}	$0.7V_{DD}$	V_{DD}	$0.7V_{DD}$	V_{DD}	V	9
VLOW	X_{IN} Low Voltage	0	$0.3V_{DD}$	0	$0.3V_{DD}$	0	$0.3V_{DD}$	V	10
Tr/Tf	X_{IN} Rise and Fall Times		10.0		10		10	ns	10
TCCJ	X_{IN} Cycle to Cycle Jitter		500		500		500	ps	11,12
Txs	Crystal Start-up Time		30		30		30	ms	12,9
P4 Mode CPU at 0.7V									
TDC	CPUT/C Duty Cycle	45	55	45	55	45	55	%	7,11,14,21,22
TPeriod	CPUT/C Period	9.85	10.2	7.35	7.65	4.85	5.1	ns	7,11,14,21,22
Tr/Tf	CPUT/C Rise and Fall Times	175	700	175	700	175	700	ps	23,24
	Rise/Fall Matching		20%		20%		20%		23,26,24
Delta Tr/Tf	Rise/Fall Time Variation		125		125		125	ps	11,23,22

Notes:

- Multiple Supplies:** The Voltage on any input or I/O pin cannot exceed the power pin during power-up. Power supply sequencing is NOT required.
- All notes for this table may be found at the end of the table, on page 13.

AC Parameters (continued)

Parameter	Description	100 MHz		133MHz		200 MHz		Unit	Notes ^[4]
		Min.	Max.	Min.	Max	Min.	Max		
TSKEW	CPUCS_T/C to CPUT/C Clock Skew	0	200	0	150	0	200	ps	11,15,21,22
TCCJ	CPUT/C Cycle to Cycle Jitter	-150	+150	-150	+150	-200	+200	ps	11,15,21,22
Vcross	Crossing Point Voltage at 0.7V Swing	280	430	280	430	280	430	mV	22
P4 Mode CPU at 1.0V									
TDC	CPUT/C Duty Cycle	45	55	45	55	45	55	%	11,14,21
TPeriod	CPUT/C Period	9.85	10.2	7.35	7.65	4.85	5.1	nS	11,14,21
Differential Tr/Tf	CPUT/C Rise and Fall Times	175	467	175	467	175	467	ps	13,15,25
TSKEW	CPUCS_T/C to CPUT/C Clock Skew	0	200	0	150	0	200	0	11,15,21
TCCJ	CPUT/C Cycle to Cycle Jitter	-150	+150	-150	+150	-200	+200	ps	11,15,21
Vcross	Crossing Point Voltage at 1V Swing	510	760	510	760	510	760	mV	26
SE-DeltaSlew	Absolute Single-ended Rise/Fall Waveform Symmetry		325		325		325	ps	24,31
K7 Mode									
TDC	CPUOD_T/C Duty Cycle	45	55	45	55	45	55	%	11,14
TPeriod	CPUOD_T/C Period	9.98	10.5	7.5	8.0	5	5.5	ns	11,14
TLOW	CPUOD_T/C LOW Time	2.8		1.67		2.8		ns	11,14
Tf	CPUOD_T/C Fall Time	0.4	1.6	0.4	1.6	0.4	1.6	ns	11,13
TSKEW	CPUCS_T/C to CPUT/C Clock Skew	0	200	0	150	0	200	0	11,15,21
TCCJ	CPUOD_T/C Cycle to Cycle Jitter	-150	+150	-150	+150	-200	+200	ps	11,14
VD	Differential Voltage AC	0.4	Vp+.6V	0.4	Vp+.6V	0.4	Vp+.6V	V	20
VX	Differential Crossover Voltage	500	1100	500	1100	500	1100	mV	19
CHIPSET CLOCK									
TDC	CPUCS_T/C Duty Cycle	45	55	45	55	45	55	%	7,11,14
TPeriod	CPUCS_T/C Period	10.0	10.5	15	15.5	10.0	10.5	ns	7,11,14
Tr / Tf	CPUCS_T/C Rise and Fall Times	0.4	1.6	0.4	1.6	0.4	1.6	ns	7,11,13
VD	Differential Voltage AC	0.4	Vp+.6V	0.4	Vp+.6V	0.4	Vp+.6V	V	27
VX	Differential Crossover Voltage	$0.5 \cdot V_{DDI} - 0.2$	$0.5 \cdot V_{DDI} + 0.2$	$0.5 \cdot V_{DDI} - 0.2$	$0.5 \cdot V_{DDI} + 0.2$	$0.5 \cdot V_{DDI} - 0.2$	$0.5 \cdot V_{DDI} + 0.2$	V	21
AGP									
TDC	AGP(0:2) Duty Cycle	45	55	45	55	45	55	%	7,11,14
TPeriod	AGP(0:2) Period	15	16	15	16	15	16	ns	7,11,14
THIGH	AGP(0:2) HIGH Time	5.25		5.25		5.25		ns	11,16
TLOW	AGP(0:2) LOW Time	5.05		5.05		5.05		ns	11,17
Tr / Tf	AGP(0:2) Rise and Fall Times	0.4	1.6	0.4	1.6	0.4	1.6	ns	11,13
TSKEW	Any AGP to Any AGP clock Skew		250		250		250	ps	11,15
TCCJ	AGP(0:2) Cycle to Cycle Jitter		500		500		500	ps	11,14,15
PCI									
TDC	PCI(_F,1:6) Duty Cycle	45	55	45	55	45	55	%	7,11,14
TPeriod	PCI(_F,1:6) Period	30.0		30.0		30.0		ns	7,11,14

AC Parameters (continued)

Parameter	Description	100 MHz		133MHz		200 MHz		Unit	Notes ^[4]
		Min.	Max.	Min.	Max	Min.	Max		
THIGH	PCI(_F,1:6) HIGH Time	12.0		12.0		12.0		ns	11,16
TLOW	PCI(_F,1:6) LOW Time	12.0		12.0		12.0		ns	11,17
Tr / Tf	PCI(_F,1:6) Rise and Fall Times	0.5	2.5	0.5	2.5	0.5	2.5	ns	11,13
TSKEW	Any PCI to Any PCI Clock Skew		500		500		500	ps	11,15
TCCJ	PCI(_F,1:6) Cycle to Cycle Jitter		500		500		500	ps	11,14,15
48MHz									
TDC	48MHz Duty Cycle	45	55	45	55	45	55	%	7,11,14
TPeriod	48MHz Period	20.8299	20.8333	20.8299	20.8333	20.8299	20.8333	ns	7,11,14
Tr / Tf	48MHz Rise and Fall Times	1.0	4.0	1.0	4.0	1.0	4.0	ns	11,13
TCCJ	48MHz Cycle to Cycle Jitter		500		500		500	ps	11,14,15
24MHz									
TDC	24MHz Duty Cycle	45	55	45	55	45	55	%	7,11,14
TPeriod	24MHz Period	41.660	41.667	41.660	41.667	41.660	41.667	ns	7,11,14
Tr / Tf	24MHz Rise and Fall Times	1.0	4.0	1.0	4.0	1.0	4.0	ns	11,13
TCCJ	24MHz Cycle to Cycle Jitter		500		500		500	ps	11,14,15
REF									
TDC	REF Duty Cycle	45	55	45	55	45	55	%	7,11,14
TPeriod	REF Period	69.8413	71.0	69.8413	71.0	69.8413	71.0	ns	7,11,14
Tr / Tf	REF Rise and Fall Times	1.0	4.0	1.0	4.0	1.0	4.0	ns	11,13
TCCJ	REF Cycle to Cycle Jitter		1000		1000		1000	ps	11,14,15
DDR									
VX	Crossing Point Voltage of DDRT/C	$0.5 \cdot V_{DD} - 0.2$	$0.5 \cdot V_{DDD} + 0.2$	$0.5 \cdot V_{DD} - 0.2$	$0.5 \cdot V_{DD} + 0.2$	$0.5 \cdot V_{DD} - 0.2$	$0.5 \cdot V_{DD} + 0.2$	V	19
VD	Differential Voltage Swing	0.7	$V_{DDD} + 0.6$	0.7	$V_{DDD} + 0.6$	0.7	$V_{DDD} + 0.6$	V	20
TDC	DDRT/C(0:5) Duty Cycle	45	55	45	55	45	55	%	21
TPeriod	DDRT/C(0:5) Period	9.85	10.2	14.85	15.3	9.85	10.2	ns	21
Tr / Tf	DDRT/C(0:5) Rise/Fall Slew Rate	1	3	1	3	1	3	V/ns	13
TSKEW	DDRT/C to Any DDRT/C Clock Skew		100		100		100	ps	11,15,21
TCCJ	DDRT/C(0:5) Cycle to Cycle Jitter		±75		±75		±75	ps	11,15,21
THPJ	DDRT/C(0:5) Half-period Jitter		±100		±100		±100	ps	11,15,21
TDelay	BUF_IN to Any DDRT/C Delay	1	4	1	4	1	4	ns	11,14
TSKEW	FBOU to Any DDRT/CSkew		100		100		100	ps	11,14
tstable	All Clock Stabilization from Power-up		3		3		3	ms	18

AC Parameters (continued)

Parameter	Description	100 MHz		133MHz		200 MHz		Unit	Notes ^[4]
		Min.	Max.	Min.	Max	Min.	Max		

Notes:

5. All outputs loaded as per maximum capacitive load table.
6. All outputs are not loaded.
7. This parameter is measured as an average over a 1- μ s duration, with a crystal center frequency of 14.31818 MHz.
8. This is required for the duty cycle on the REF clock out to be as specified. The device will operate reliably with input duty cycles up to 30/70 but the REF clock duty cycle will not be within data sheet specifications.
9. When crystal meets minimum 40-ohm device series resistance specification.
10. Measured between 0.2V_{DD} and 0.7V_{DD}.
11. All outputs loaded as per loading specified in the Table 11.
12. When X_{IN} is driven from an external clock source (3.3V parameters apply).
13. Probes are placed on the pins, and measurements are acquired between 0.4V and 2.4V for 3.3V signals and between 0.4V and 2.0V for 2.5V signals, and between 20% and 80% for differential signals.
14. Probes are placed on the pins, and measurements are acquired at 1.5V for 3.3V signals and at 1.25V for 2.5V, and 50% point for differential signals.
15. This measurement is applicable with Spread ON or spread OFF.
16. Probes are placed on the pins, and measurements are acquired at 2.4V for 3.3V signals and at 2.0V for 2.5V signals)
17. Probes are placed on the pins, and measurements are acquired at 0.4V.
18. The time specified is measured from when all VDD's reach their respective supply rail (3.3V and 2.5V) till the frequency output is stable and operating within the specifications.
19. The typical value of VX is expected to be 0.5*VDDD (or 0.5*VDDC for CPUCS signals) and will track the variations in the DC level of the same.
20. VD is the magnitude of the difference between the measured voltage level on a DDRT (and CPUCS_T) clock and the measured voltage level on its complementary DDRC (and CPUCS_C) one.
21. Measured at VX, or where subtraction of CLK-CLK# crosses 0 volts.
22. See Figure 10. for 0.7V loading specification.
23. Measured from Vol=0.175V to Voh=0.525V.
24. Measurements taken from common mode waveforms, measure rise/fall time from 0.41V to 0.86V. Rise/fall time matching is defined as "the instantaneous difference between maximum clk rise (fall) and minimum clk# fall (rise) time, or minimum clk rise (fall) and maximum clk# fall (rise) time". This parameter is designed for waveform symmetry.
25. Measurement taken from differential waveform, from -0.35V to +0.35V.
26. Measured in absolute voltage, i.e. single-ended measurement.
27. Measured at VX between the rising edge and the following falling edge of the signal.
28. Measured at VX between the falling edge and the following rising edge of the signal.
29. This parameter is intended to be 0.45*Tperiod(min) for minimum spec. and 0.55*Tperiod(min) for maximum spec.
30. Determined as a fraction of 2*(Trise-Tfall)/(Trise+Tfall).

P4 Processor SELP4_K7# = 1
Power-down Assertion (P4 Mode)

When PD# is sampled LOW by two consecutive rising edges of CPU# clock then all clock outputs except CPU clocks must be held LOW on their next HIGH to LOW transition. CPU clocks must be held with the CPU clock pin driven HIGH with a value of 2 x Iref, and CPU# undriven. Note that Figure 4

shows CPU = 133 MHz, this diagram and description is applicable for all valid CPU frequencies 66, 100, 133, 200MHz. Due to the state of internal logic, stopping and holding the REF clock outputs in the LOW state may require more than one clock cycle to complete.

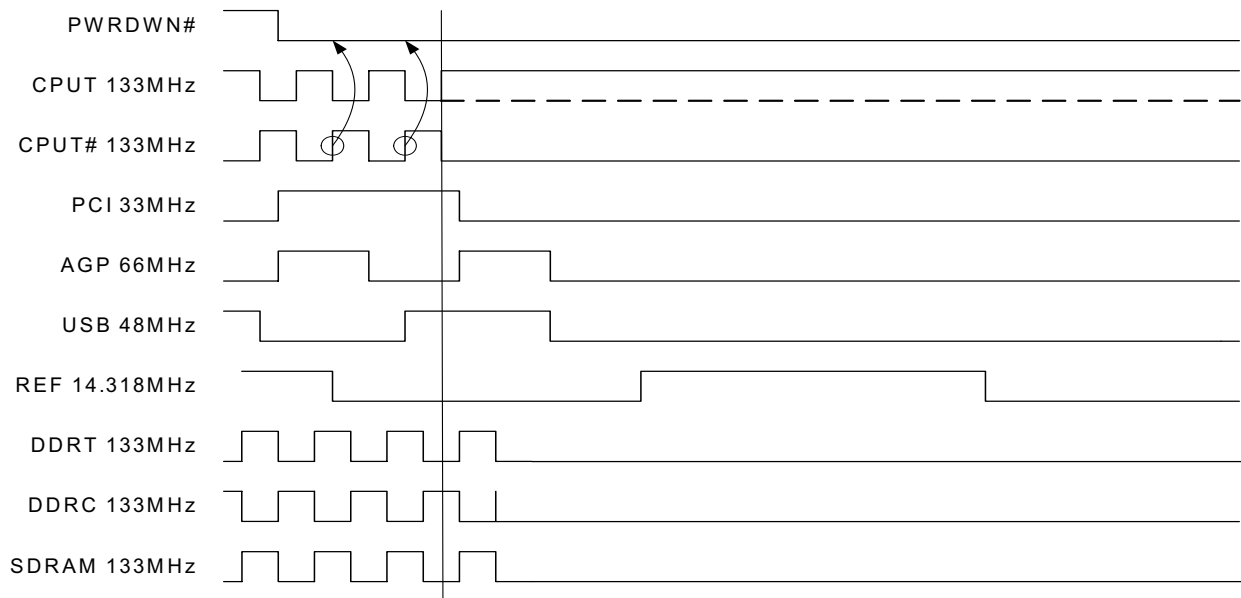
Figure 2. Power-down Assertion Timing Waveform (in P4 Mode)

Power-down Deassertion (P4 Mode)

The power-up latency needs to be less than 3 mS.

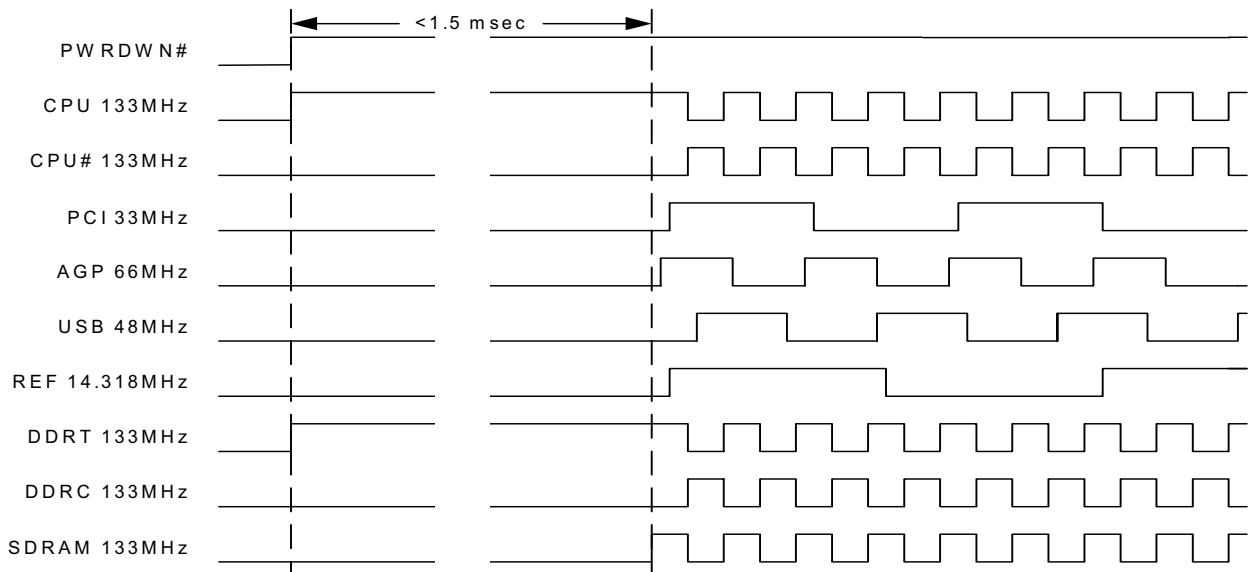

Figure 3. Power-down Deassertion Timing Waveform (in P4 Mode)

AMD K7 Processor SELP4_K7# = 0
Power-down Assertion (K7 Mode)

When the PD# signal is asserted LOW, all clocks are disabled to a LOW level in an orderly fashion prior to removing power from the part. When PD# is asserted (forced) LOW, the device transitions to a shutdown (power-down) mode and all power supplies may then be removed. When PD# is sampled LOW

by two consecutive rising edges of CPU clock, then all affected clocks are stopped in a LOW state as soon as possible. When in power-down (and before power is removed), all outputs are synchronously stopped in a LOW state (see figure3 below), all PLL's are shut off, and the crystal oscillator is disabled. When the device is shutdown, the I2C function is also disabled.

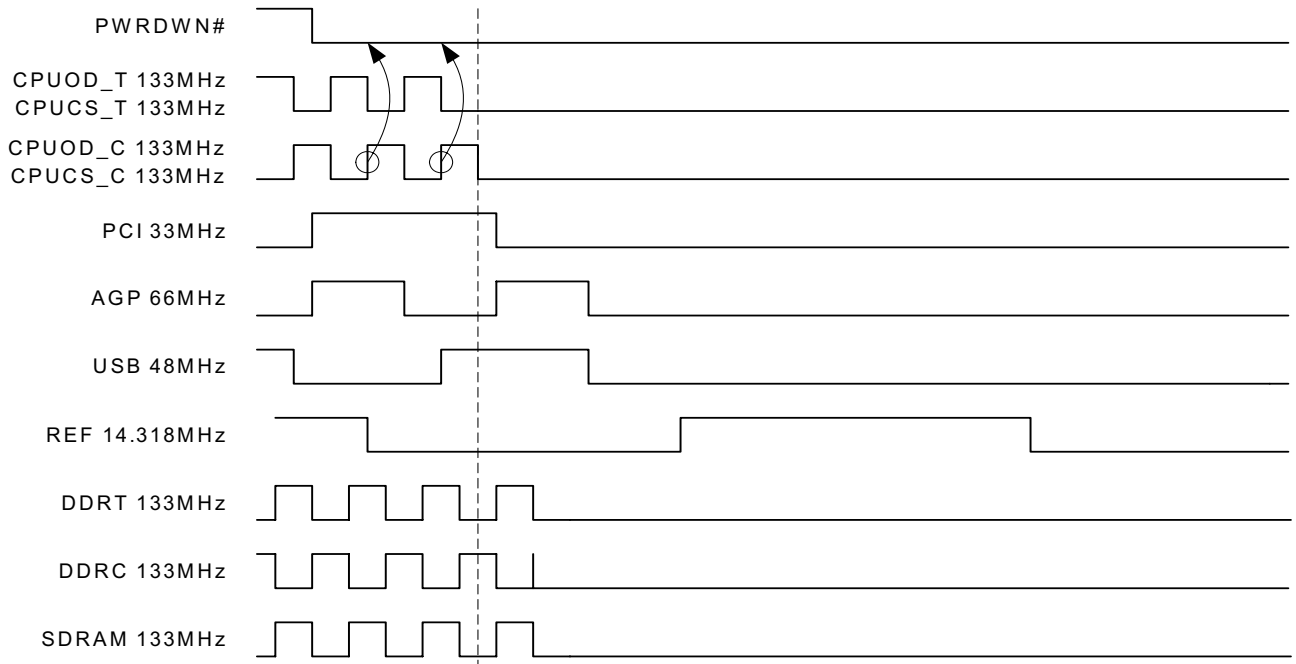

Figure 4. Power-down Assertion Timing Waveform (in K7 Mode)

Power-down Deassertion (K7 Mode)

When de-asserted PD# to HIGH level, all clocks are enabled and start running on the rising edge of the next full period in

order to guarantee a glitch-free operation, no partial clock pulses.

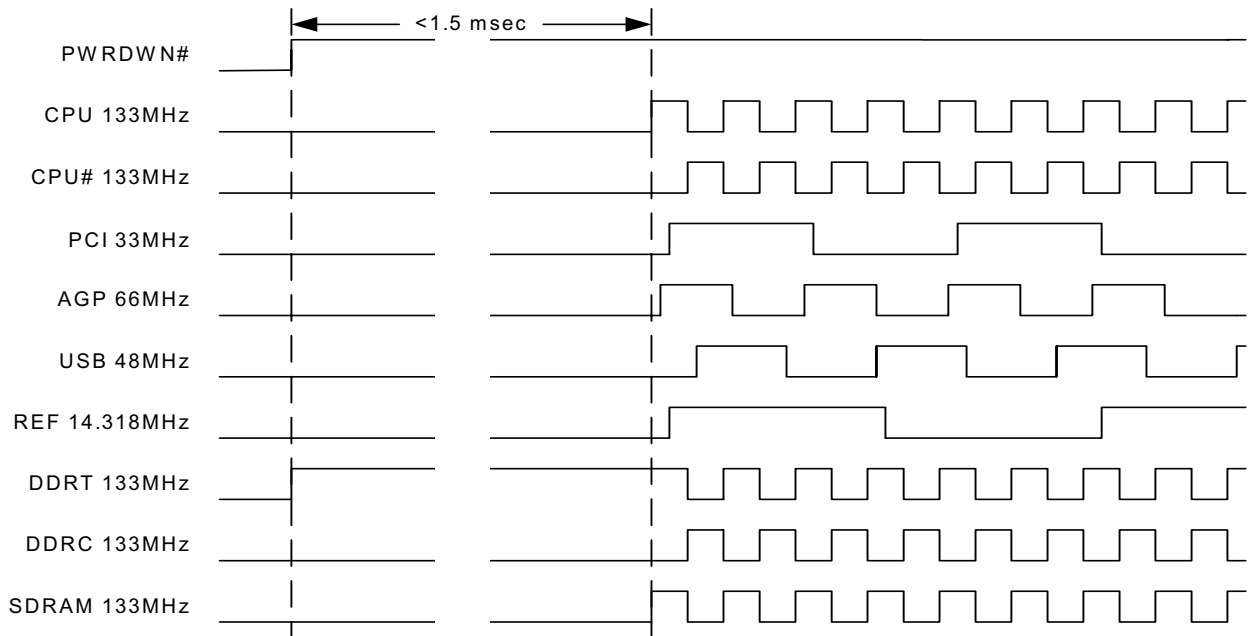

Figure 5. Power-down Deassertion Timing Waveform (in K7 mode)

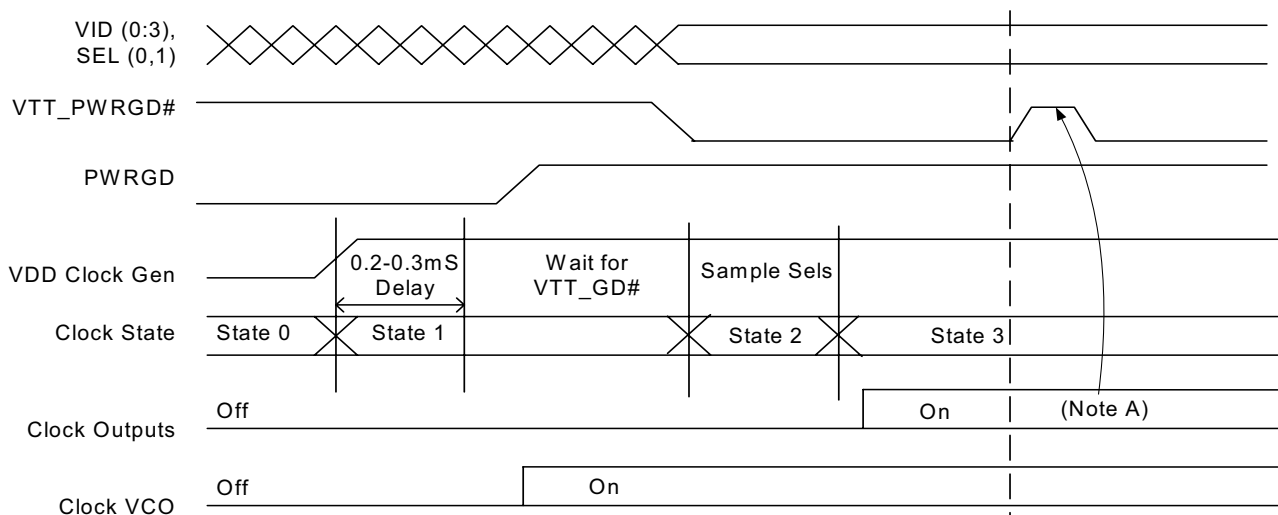

Figure 6. VTT_PWRGD# Timing Diagram (With Advanced PIII Processor SelP4_K7 = 1)^[31]

Note:

31. This time diagram shows that VTT_PWRGD# transits to a logic LOW in the first time at power-up. After the first HIGH to LOW transition of VTT_PWRGD#, device is not affected, VTT_PWRGD# is ignored.

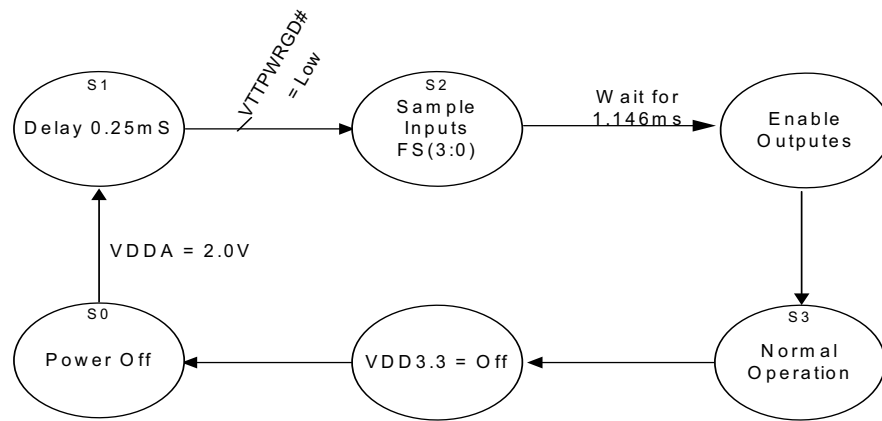

Figure 7. Clock Generator Power-up/ Run State Diagram (with P4 Processor SELP4_K7# = 1)

Connection Circuit DDRT/C Signals

For Open Drain CPU Output Signals (with K7 Processor SELP4_K7# = 0)

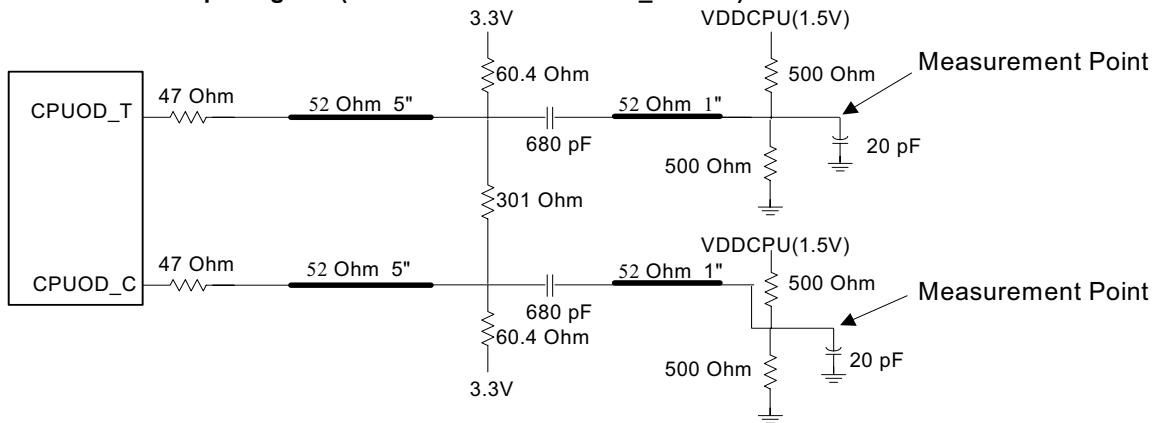

Figure 8.

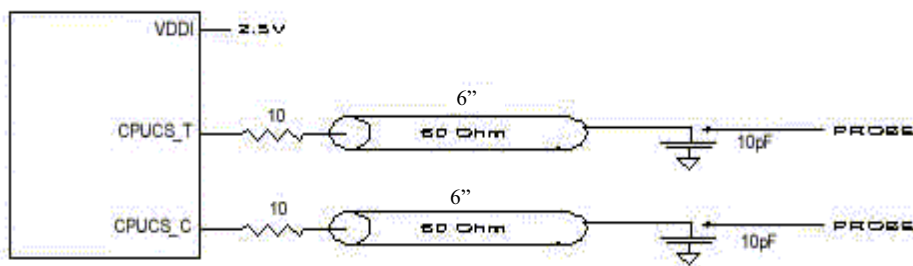

Figure 9.

Table 10. Signal Loading Table

Clock Name	Max Load (in pF)
REF (0:1), 48MHz (USB), 24_48MHz	20
AGP(0:2), SDRAM (0:11)	30
PCI_F(0:5)	30
DDRT/C (0:5), FBOUT	
CPUT/C	See Figure 10
CPUOD_T/C	See Figure 8
CPUCS_T/C	See Figure 9

For Differential CPU Output Signals (with P4 Processor SELP4_K7= 1)

The following diagram shows lumped test load configurations for the differential Host Clock Outputs.

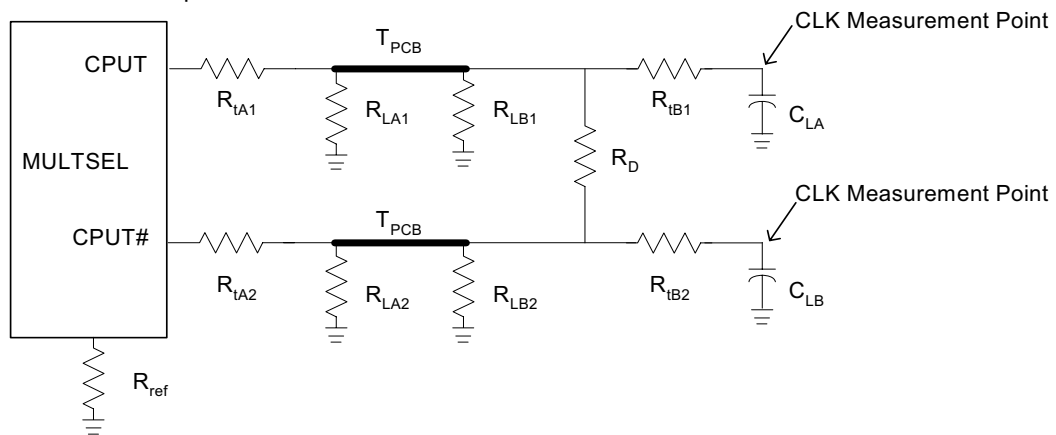
Figure 10.
Table 11. Lumped Test Load Configuration

Component	0.7V Amplitude Value	1.0V Amplitude Value
R_{tA1}, R_{tA2}	33Ω	0Ω
R_{LA1}, R_{LA2}	49.9Ω	∞
T_{PCB}	$3'' 50 \Omega Z$	$3'' 50 \Omega Z$
R_{LB1}, R_{LB2}	∞	63Ω
R_D	∞	470Ω
R_{tB1}, R_{tB2}	0Ω	33Ω
C_{LA}, C_{LB}	2 pF	2 pF
R_{ref}	$475\Omega \text{ w/mult0} = 1$	$221\Omega \text{ w/mult0} = 0$

Group Timing Relationships and Tolerances^[32]

		Offset (ps)	Tolerance (ps)	Conditions
t_{CSAGP}	CPUCS to AGP	750	500	CPUCS Leads
t_{AP}	AGP to PCI	1,250	500	AGP Leads

Note:

32. Ideally the probes should be placed on the pins. If there is a transmission line between the test point and the pin for one signal of the pair (e.g., CPU), the same length transmission line to the other signal of the pair (e.g., AGP) should be added.

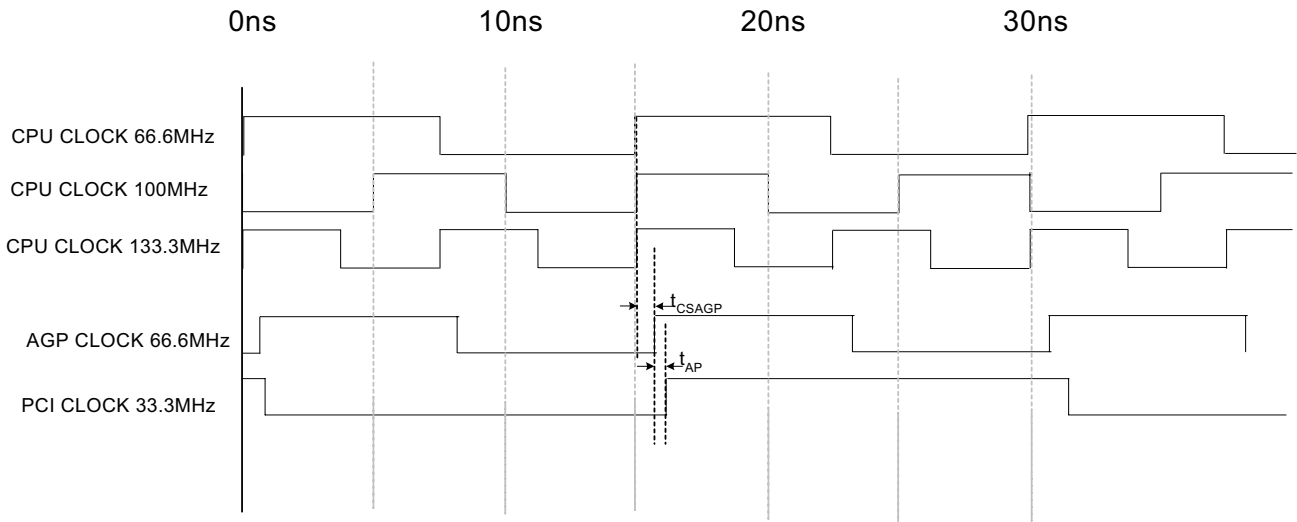
Ordering Information

Part Number	Package Type	Product Flow
CY28341OC	56-pin Shrunk Small Outline package (SSOP)	Commercial, 0° to 70°C
CY28341OCT	56-pin Shrunk Small Outline package (SSOP)–Tape and Reel	Commercial, 0° to 70°C
CY28341ZC	56-pin Thin Shrunk Small Outline package (TSSOP)	Commercial, 0° to 70°C
CY28341ZCT	56-pin Thin Shrunk Small Outline package (TSSOP)–Tape and Reel	Commercial, 0° to 70°C

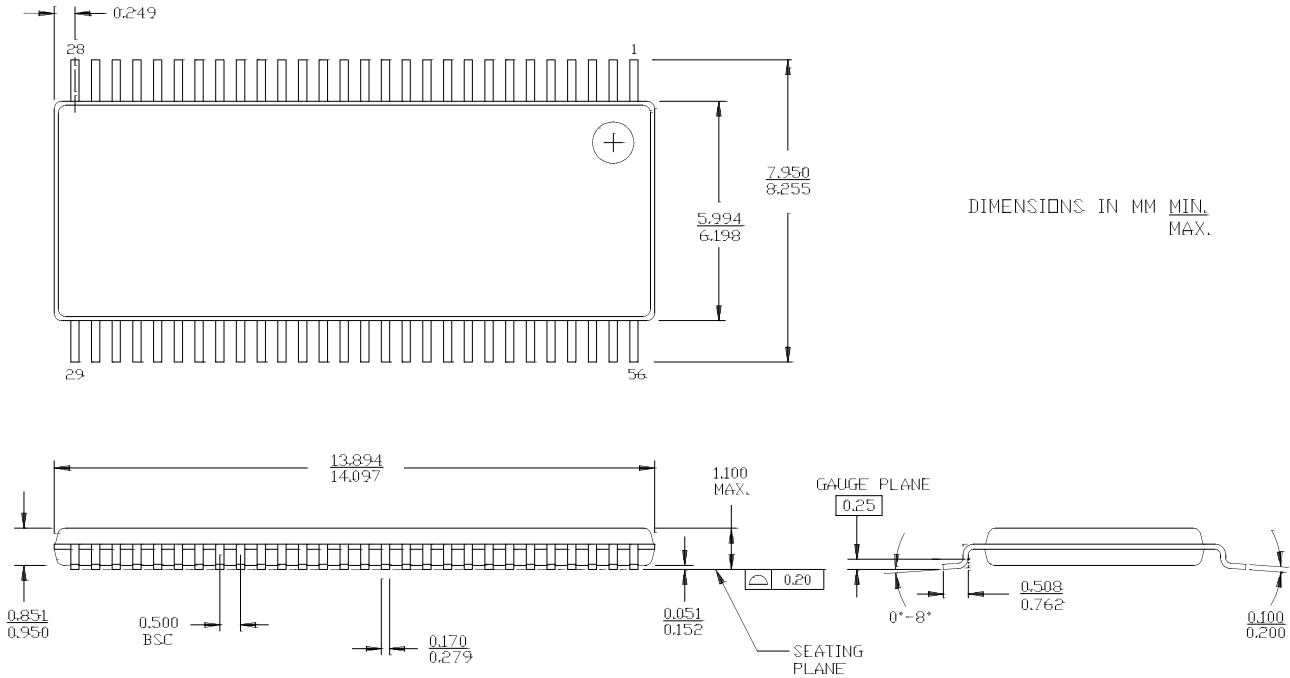
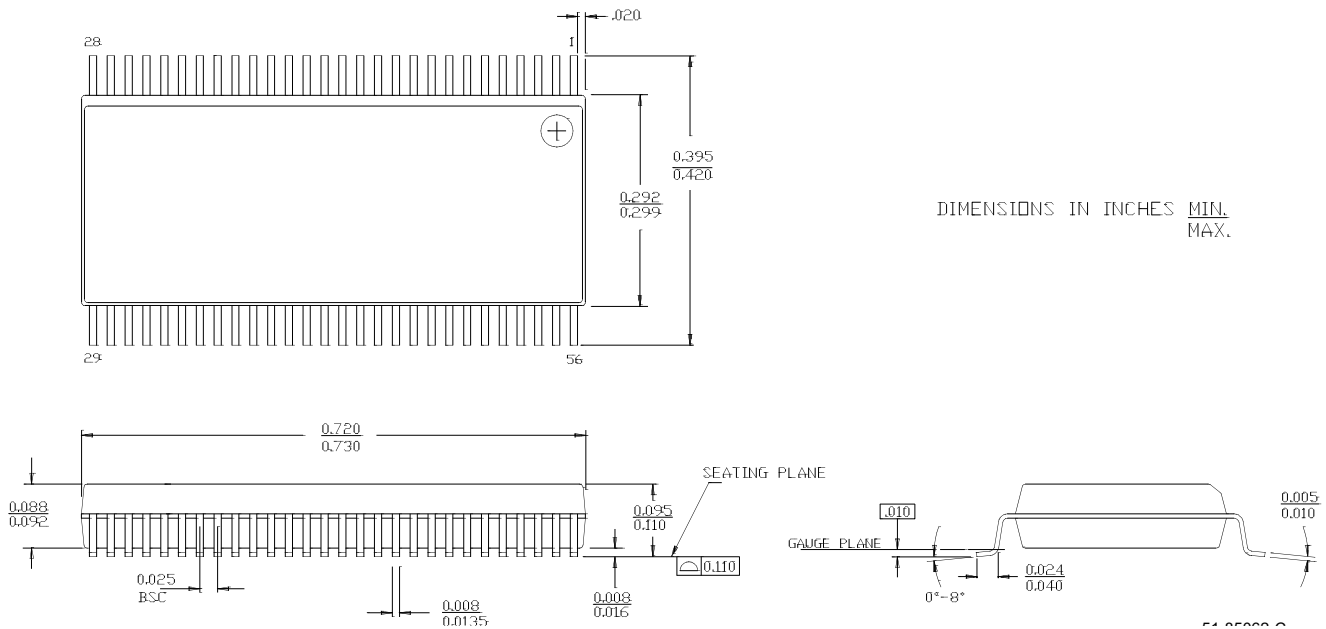
Package Drawing and Dimensions
56-lead Thin Shrunken Small Outline Package, Type II (6 mm × 12 mm) Z56

56-lead Shrunken Small Outline Package O56

While SLI has reviewed all information herein for accuracy and reliability, Spectra Linear Inc. assumes no responsibility for the use of any circuitry or for the infringement of any patents or other rights of third parties which would result from each use. This product is intended for use in normal commercial applications and is not warranted nor is it intended for use in life support, critical medical instruments, or any other application requiring extended temperature range, high reliability, or any other extraordinary environmental requirements unless pursuant to additional processing by Spectra Linear Inc., and expressed written agreement by Spectra Linear Inc. Spectra Linear Inc. reserves the right to change any circuitry or specification without notice.