

Typical Applications

The HMC286 / HMC286E is ideal for:

- BlueTooth
- Home RF
- 802.11 WLAN Radios
- PCMCIA Platforms

Features

- 2.4 GHz LNA
- Noise Figure: 1.7 dB
- Gain: 19 dB
- Single Supply: +3V
- No External Components
- Ultra Small SOT26 Package

Functional Diagram

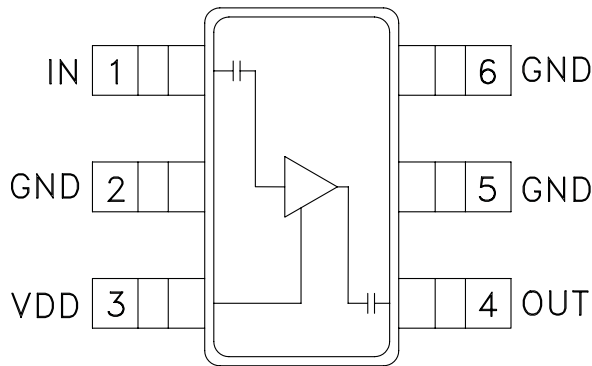

General Description

The HMC286 & HMC286E are low cost Low Noise Amplifiers (LNA) for 2.3 to 2.5 GHz spread spectrum applications. The LNA provides 19 dB of gain and a 1.7 dB noise figure from a single positive +3V power supply that consumes only 8.5mA. The typical output 1 dB compression point is +6 dBm at 2.4 GHz. The compact LNA design utilizes on-chip matching for repeatable gain and noise figure performance. In addition, eliminating the external matching circuitry also reduces the overall size of the LNA function. The HMC286 & HMC286E were designed to meet the size constraints of PCMCIA platforms and uses the SOT26 package that occupies 0.118" x 0.118", which makes them a small fully integrated solution that can be easily implemented with other 2.4 GHz ASICs.

Electrical Specifications, $T_A = +25^\circ \text{C}$, $V_{dd} = +3\text{V}$

Parameter	Min.	Typ.	Max.	Units
Frequency Range	2.3 - 2.5			GHz
Gain	16	19		dB
Gain Variation Over Temperature		0.015	0.03	dB/°C
Gain Flatness		±1.25		dB
Noise Figure		1.7	2.5	dB
Input Return Loss		12		dB
Output Return Loss		4.5		dB
Output 1 dB Compression (P1dB)	2	6		dBm
Output Third Order Intercept (IP3)	9	12		dBm
Supply Current (I _{dd})		8.5	12.5	mA

Broadband Gain & Return Loss

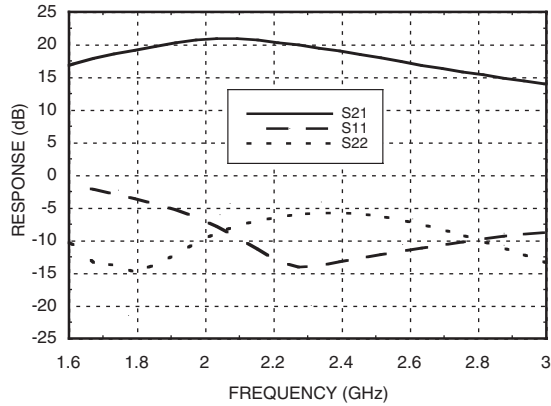

Broadband Noise Figure

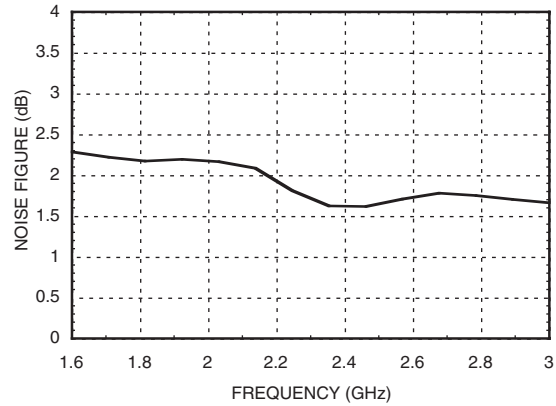

Gain vs. Temperature

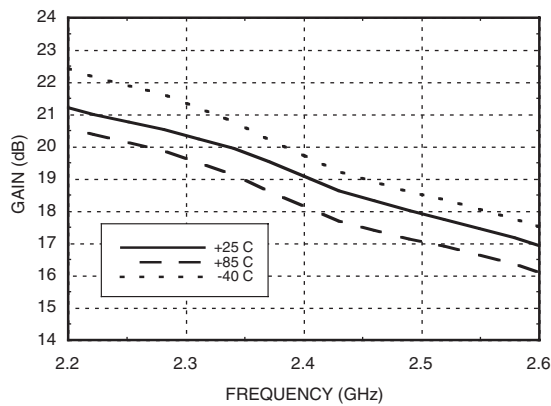

Noise Figure vs. Temperature

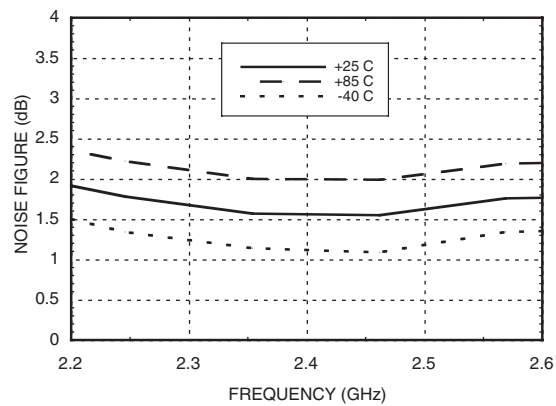

Input Return Loss vs. Temperature

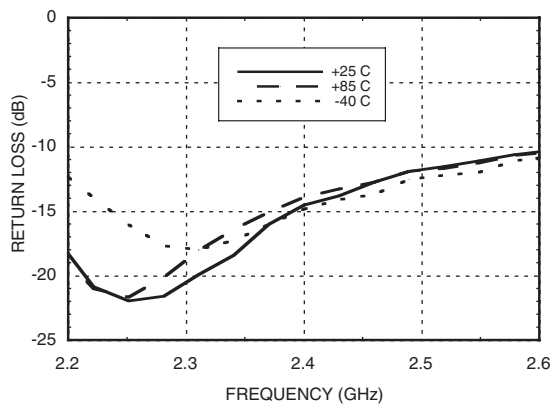

Output Return Loss vs. Temperature

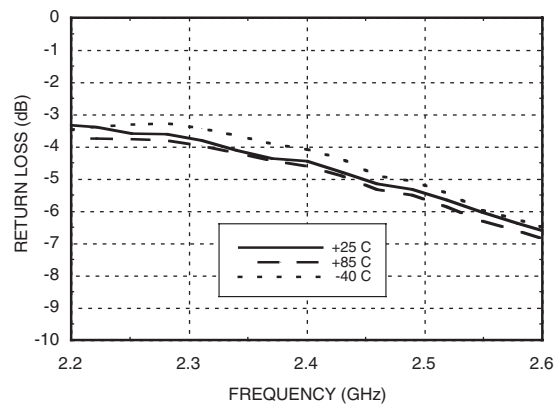



Output P1dB vs. Temperature

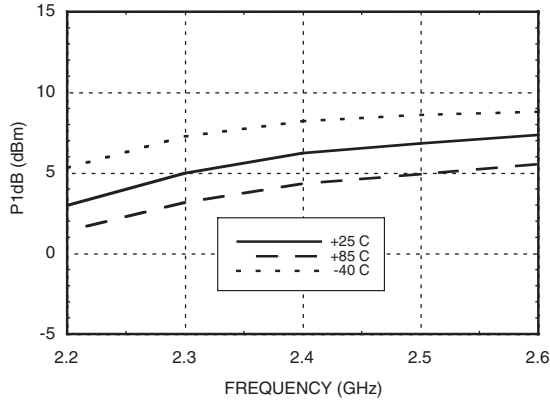

Power Compression @ 2.4 GHz

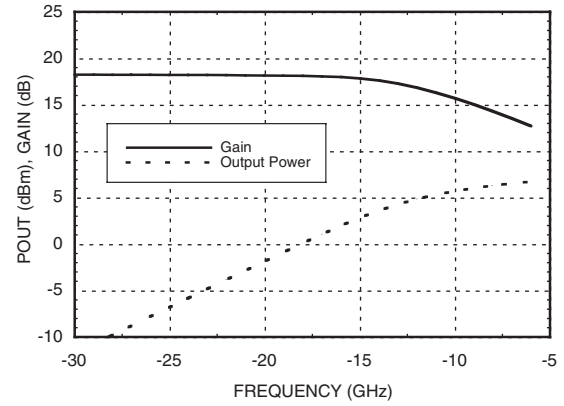

Output IP3 vs. Temperature

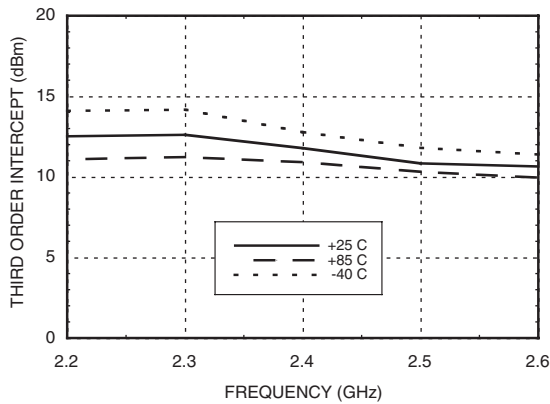

Reverse Isolation vs. Temperature

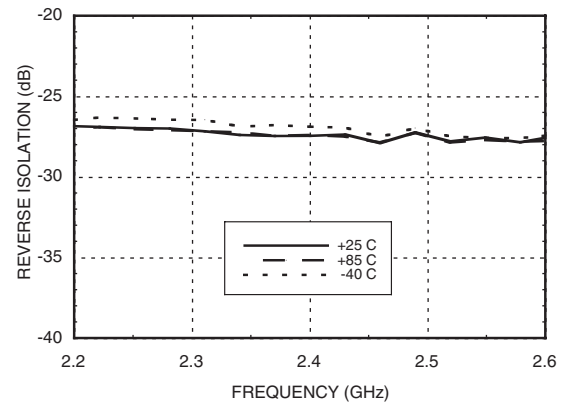

Absolute Maximum Ratings

Drain Bias Voltage (Vdd)	+7.0 Vdc
RF Input Power (RFIn)(Vdd = +3.0 Vdc)	0 dBm
Channel Temperature	150 °C
Continuous Pdiss (T = 85 °C) (derate 6.35 mW/°C above 85 °C)	0.413 W
Thermal Resistance (channel to lead)	157 °C/W
Storage Temperature	-65 to +150 °C
Operating Temperature	-40 to +85 °C
ESD Sensitivity (HBM)	Class 1A



ELECTROSTATIC SENSITIVE DEVICE
OBSERVE HANDLING PRECAUTIONS

Outline Drawing

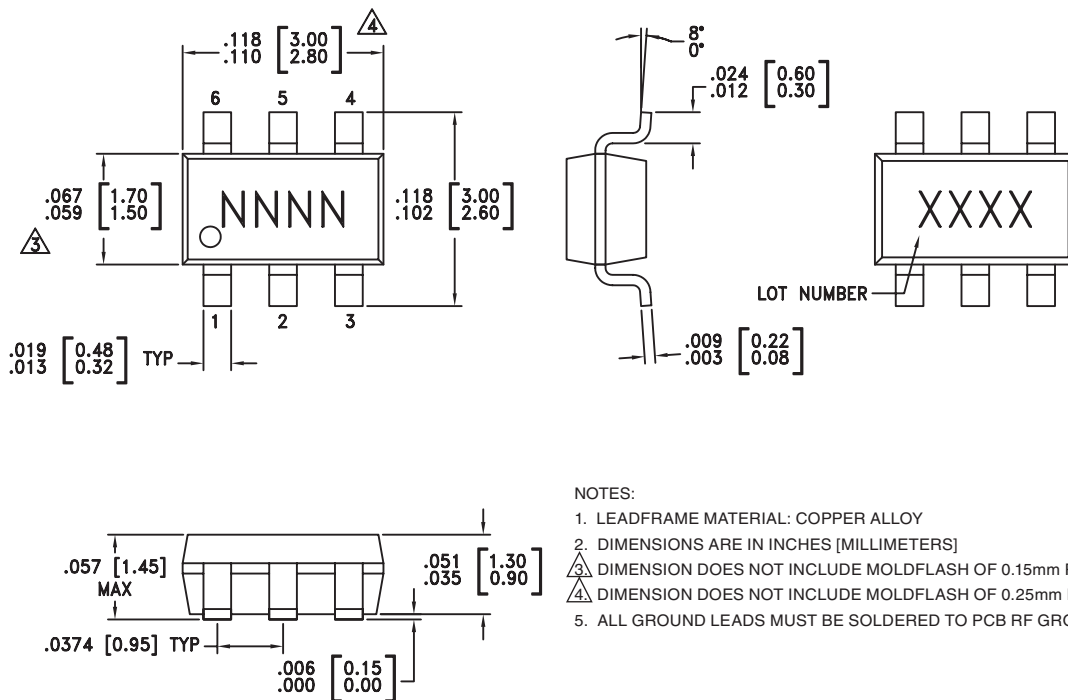

Package Information



Part Number	Package Body Material	Lead Finish	MSL Rating	Package Marking ^[3]
HMC286	Low Stress Injection Molded Plastic	Sn/Pb Solder	MSL1 ^[1]	H286 XXXX
HMC286E	RoHS-compliant Low Stress Injection Molded Plastic	100% matte Sn	MSL1 ^[2]	286E XXXX

[1] Max peak reflow temperature of 235 °C

[2] Max peak reflow temperature of 260 °C

[3] 4-Digit lot number XXXX

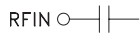
Pin Descriptions

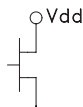
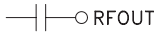
Pin Number	Function	Description	Interface Schematic
1	RFIN	This pin is AC coupled and matched to 50 Ohms.	RFIN 
2, 5, 6	GND	These pins must be connected to RF/DC ground.	 GND
3	VDD	Power supply voltage.	 Vdd
4	RFOUT	This pin is AC coupled and matched to 50 Ohms.	 RFOUT

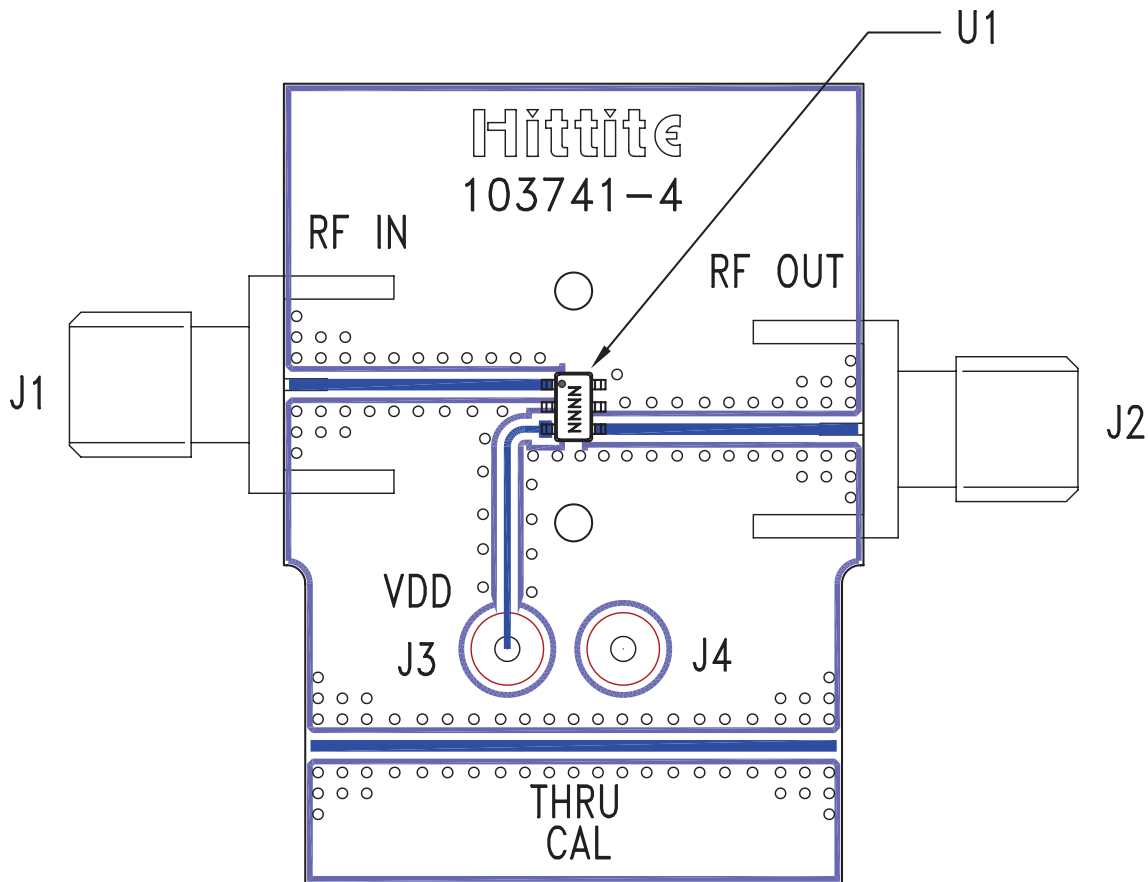
Evaluation PCB

List of Materials for Evaluation PCB 103743^[1]

Item	Description
J1, J2	PCB Mount SMA Connector
J3, J4	DC Pin
U1	HMC286 / HMC286E Amplifier
PCB [2]	103741 Eval Board

[1] Reference this number when ordering complete evaluation PCB

[2] Circuit Board Material: Roger 4350

The circuit board used in the final application should use RF circuit design techniques. Signal lines should have 50 ohm impedance while the package ground leads should be connected directly to the ground plane similar to that shown above. A sufficient number of VIA holes should be used to connect the top and bottom ground planes. The evaluation circuit board shown is available from Hittite upon request.