

Four Channel Integrated Power Management IC for Handheld Portable Equipment

FEATURES

- Multiple Patents Pending
- Li+ Battery Charger with Integrated MOSFET
 - ON/OFF Control and Status Indication
- Three Integrated Regulators
 - 350mA PWM Step-Down DC/DC
 - 500mA PWM Step-Down DC/DC
 - Step-Up DC/DC with OVP for WLED Bias
- Minimal External Components
- 4x4mm, Thin-QFN (TQFN44-24) Package
 - Only 0.75mm Height
 - RoHS Compliant

APPLICATIONS

- Portable Devices and PDAs
- Digital Media Players
- Battery Operated Devices
- GPS Receivers, etc.

GENERAL DESCRIPTION

The patent-pending ACT8700 is a complete, cost-effective, highly-efficient *ActivePMU™* power management solution that is ideal for a wide range of portable handheld equipment. This device integrates two step-down DC/DC converters, one step-up DC/DC converter with over-voltage protection (OVP) for WLED bias, and a full-featured, linear-mode Li+ battery charger-into a single, thin, space-saving package.

REG1 and REG2 are fixed-frequency, current-mode PWM step-down DC/DC converters that are optimized for high efficiency and are capable of supplying up to 350mA and 500mA, respectively. REG3 is a fixed-frequency, step-up DC/DC converter that safely and efficiently biases a string of up to seven white-LEDs for backlighting. The battery charger incorporates an internal power MOSFET for constant-current/constant-voltage, thermally regulated charging of a single-cell Li+ battery.

The ACT8700 is available in a tiny 4mm x 4mm 24-pin Thin-QFN package that is just 0.75mm thin.

SYSTEM BLOCK DIAGRAM

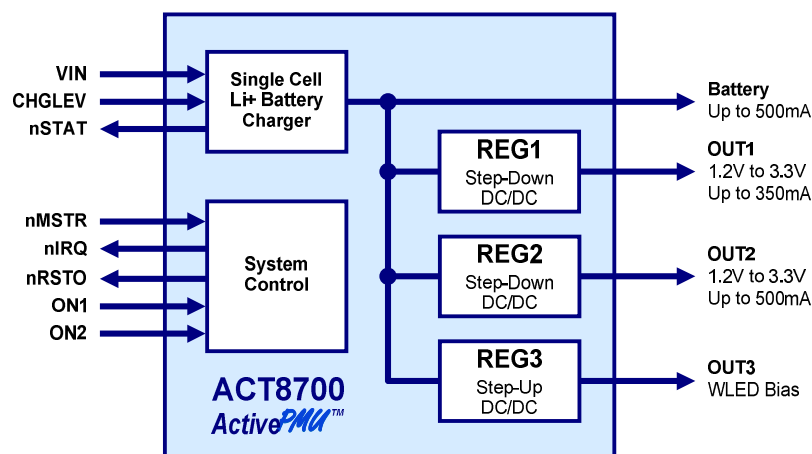

PRODUCT OPTIONS

Block	Function	Output Voltage ^①	Capability ^②
CHGR	Battery Charger	4.20V (4.10V to 4.30V available)	100mA/500mA
REG1	Step-Down DC/DC	1.2V, 1.5V, 1.8V, 2.5V, 3.0V, or 3.3V	350mA
REG2	Step-Down DC/DC		500mA
REG3	Step-Up DC/DC	Up to 27.5V	Up to 7 WLEDs

①: Output voltage options detailed in this table represent standard voltage options, and are available for samples or production orders. Contact Active-Semi for more information regarding semi-custom output voltage combinations.

②: Contact factory for additional available products or custom requirements.

FUNCTIONAL BLOCK DIAGRAM

