

SOP-8



MSOP-8



Pin Definition:

- | | |
|--------|------------|
| 1. SC | 5. Comp |
| 2. SE | 6. Vcc |
| 3. CT | 7. Ipk |
| 4. Gnd | 8. Vdriver |

General Description

The TS3063 is a monolithic switching regulator and subsystem intended for use as DC to DC converter. It contains an internal temperature compensated reference, comparator, controlled duty cycle oscillator with an active peak current limit circuit, drive and a high current output switch.

The TS3063 is specifically designed to be incorporated in step-up, step-down and voltage inverting converter applications. The TS3063 is offered in SOP-8 and MSOP-8 package

Features

- Power forward control circuit
- Operating voltage from 3V to 40V
- Low standby current
- Current limit adjustable
- Output switch current up to 800mA
- Variable oscillator frequency up to 180kHz (max.)
- Output voltage adjustable

Pin Description

Name	Description
SC	Switch Collector
SE	Switch Emitter
CT	Timing Capacitor
GND	Ground
COMP.	Comparator Inverting Input
V _{CC}	V _{CC} Collector
I _{PK}	IPK Sense
V _{DRIVER}	Driver

Applications

- Charger
- xD-ROM, xDSL products
- DC to DC converter

Ordering Information

Part No.	Package	Packing
TS3063CS RL	SOP-8	2.5Kpcs / 13" Reel
TS3063CB RL	MSOP-8	2.5Kpcs / 13" Reel

Schematic Diagram

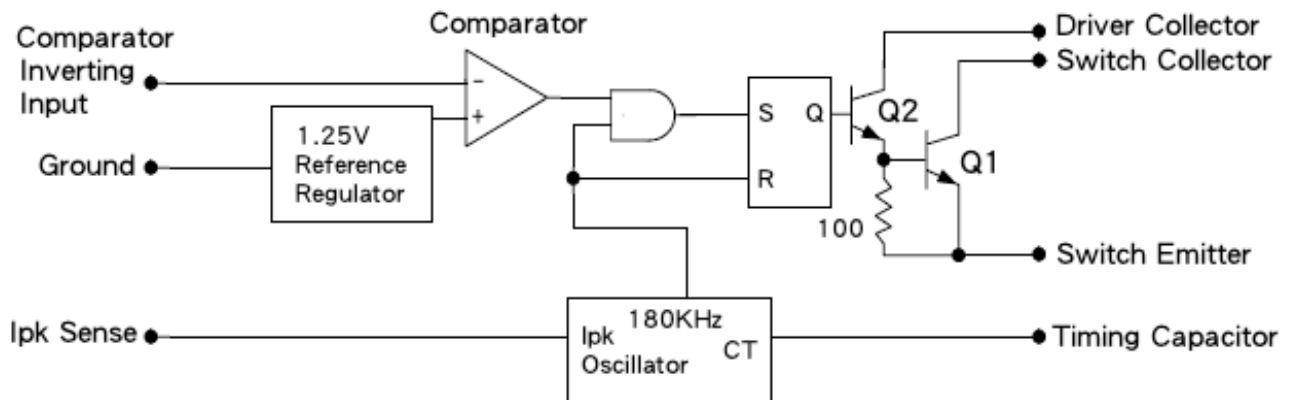

Absolute Maximum Rating

Parameter	Symbol	Maximum	Unit
Supply Voltage	V_{CC}	40	V
Comparator Input Voltage Range	V_{FB}	- 0.3 ~ 40	V
Switch Collector Output Voltage	$V_{C(SW)}$	40	V
Switch Emitter Voltage	$V_{E(SW)}$	40	V
Switch Collector to Emitter Voltage	$V_{CE(SW)}$	40	V
Driver Collector Voltage	$V_{C(DRIVER)}$	40	V
Driver Collector Current (note 1)	$I_{C(DRIVER)}$	100	mA
Output Switching Current	I_{SW}	800	mA
Power Dissipation	SOP-8	0.5	W
	MSOP-8	0.35	
Junction Temperature Range	T_J	+150	°C
Storage Temperature Range	T_{STG}	-65 ~ +150	°C

Note: Maximum package power dissipation limits must be observed

Electrical Characteristics ($V_{CC} = 5V$, $T_a = 25^\circ C$; unless otherwise noted.)

Parameter	Symbol	Test Conditions	Min	Typ	Max	Unit
Oscillator (OSC)						
Frequency	F_{OSC}	$C_T = 100pF$, $V_{pin5} = 0V$	--	--	180	KHz
Charge Current	I_{CHARGE}	$V_{CC} = 5V \sim 40V$	30	30	45	uA
Discharge Current	$I_{DISCHARGE}$	$V_{CC} = 5V \sim 40V$	180	230	290	uA
Discharge to Charge current ratio	$I_{DISCHARGE} / I_{CHARGE}$	Pin7 to V_{CC}	5.2	6.5	7.5	--
Current Limit Sense Voltage	$V_{IPK(SENSE)}$	$I_{DISCHARGE} = I_{CHARGE}$	250	--	350	mV

Output switch (note1)

Saturation Voltage	$V_{CE(SAT)}$	$I_{SW} = 0.8A$, pin1, 8 connected	--	1.0	1.3	V
Saturation Voltage	$V_{CE(SAT)}$	$I_{SW} = 0.8A$, $R_{pin8} = 82ohm$ to V_{CC} , force beta = 20	--	0.45	0.8	V
DC current gain	H_{FE}	$I_{SW} = 0.8A$, $V_{CE} = 5V$	50	75	--	--
Collector off-state current	$I_{C(OFF)}$	$V_{CE} = 40V$	--	0.01	100	uA

Comparator

Threshold Voltage	V_{REF}		1.225	1.25	1.275	V
Line regulation	REG_{LINE}	$V_{CC} = 3V \sim 40V$	--	1.4	5	mV

Total device

Supply Current	I_{CC}	$V_{CC} = 5V \sim 40V$, $C_T = 1nF$, pin7= V_{CC} , pin5> V_{TH} , pin2=Gnd, remaining pins open	--	3	4	mA
----------------	----------	---	----	---	---	----

Notes1: Low duty cycle pulse techniques are used during test to maintain junction temperature as close to ambient temperature as possible

Note 2: If the output switch is driven into hard saturation (non-Darlington configuration) at low switch currents ($\leq 300\text{mA}$) and high driver currents ($\geq 30\text{mA}$), it may take up to $2\mu\text{s}$ for it to come out of saturation. This condition will shorten the off time at frequencies $\geq 30\text{kHz}$, and is magnified at high temperature. This condition does not occur with a Darlington configuration, since the output switch cannot saturate. If a non-Darlington configuration is used, the following output drive condition is recommended:

Forced Beta of output switch: $I_c \text{ output} / (I_c \text{ driver} - 7\text{mA}^*) \geq 10$

* The 100ohm resistor in the emitter of the driver divide requires about 7mA before the output switch conducts.

Electrical Characteristics Curve

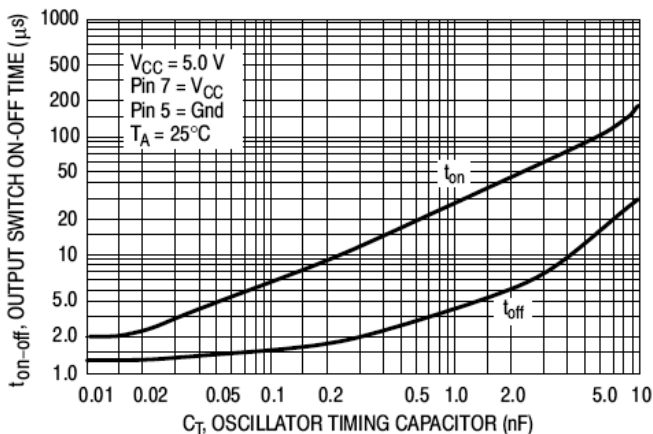

Figure 1. Output Switch On-Off Time vs. Oscillator Timing Capacitor

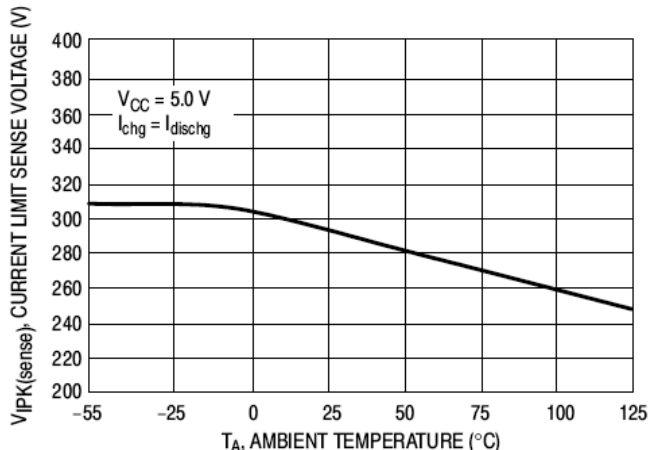

Figure 2. Current Limit Sense Voltage vs. Temperature

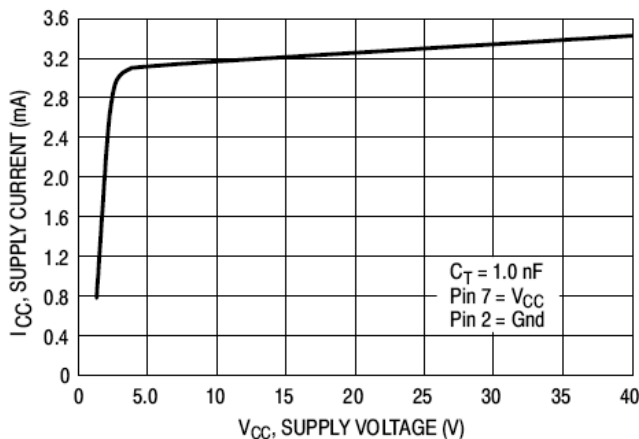
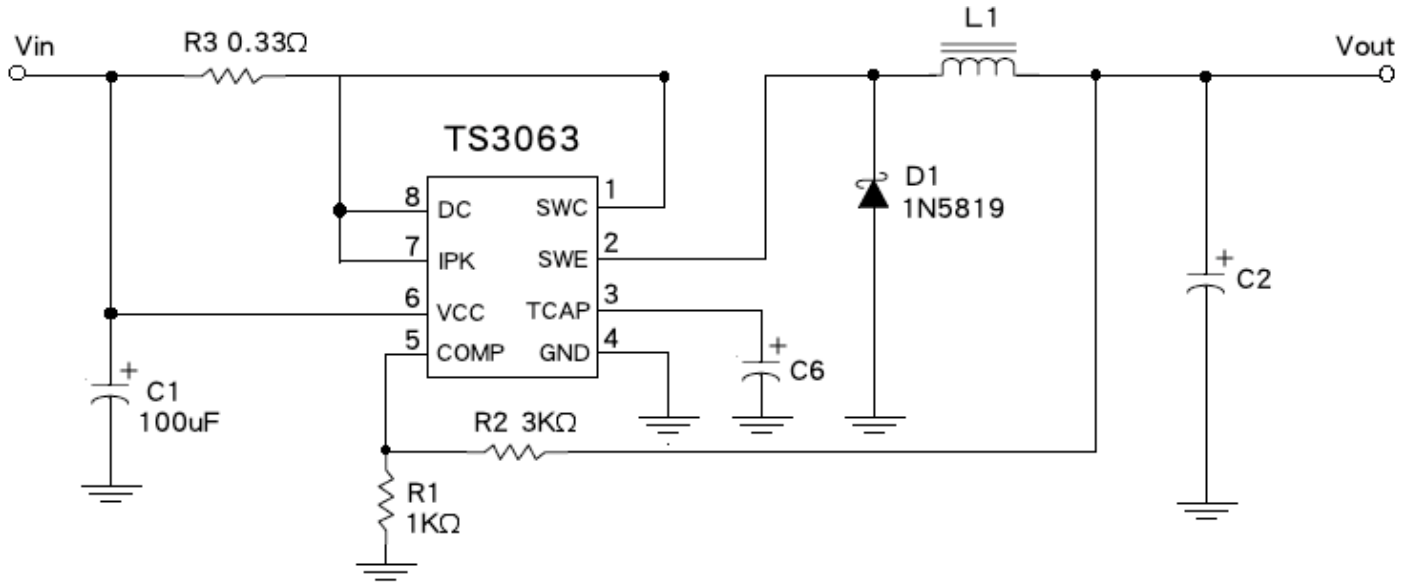

Figure 3. Standby Supply Current vs. Supply Voltage

Typical Application Circuit



Step-Down Converter

Quick Design Component Selection Table for 5V output version

L (uH)	Cout (uF)	CT (pF)	Vin (V)	Iin (mA)	Pin (W)	Vout (V)	Iout (A)	Pout (W)	Frequency (KHz)	η (%)
100	470	150	12	0.261	3.132	5.002	0.5	2.501	96	80.3
330	470	200	40	0.079	3.16	5.012	0.5	2.506	36	79.3

Typical Application Circuit (Continue)

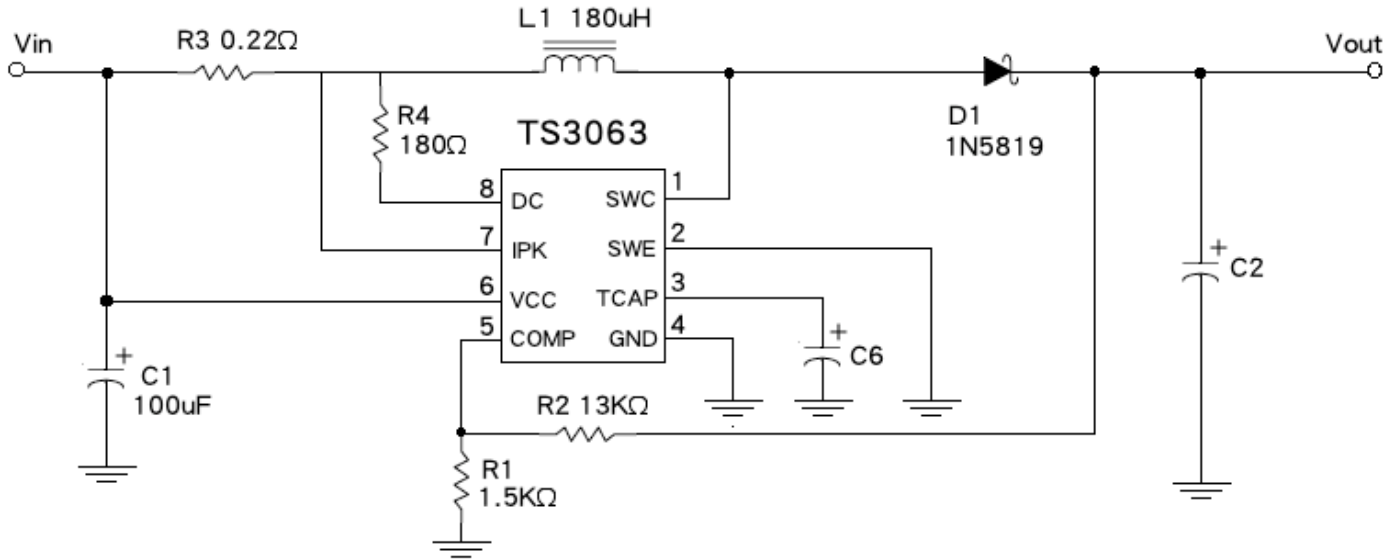

Step-Up Converter

Quick Design Component Selection Table for 5V output version

L (uH)	Cout (uF)	CT (pF)	Vin (V)	Iin (mA)	Pin (W)	Vout (V)	Iout (A)	Pout (W)	Frequency (KHz)	η (%)
100	100	150	5	292	1.46	12.046	0.1	1.2046	178	82.5
150	100	180	5	621	3.105	12.006	0.2	2.4012	166	77.3

Typical Application Circuit (Continue)

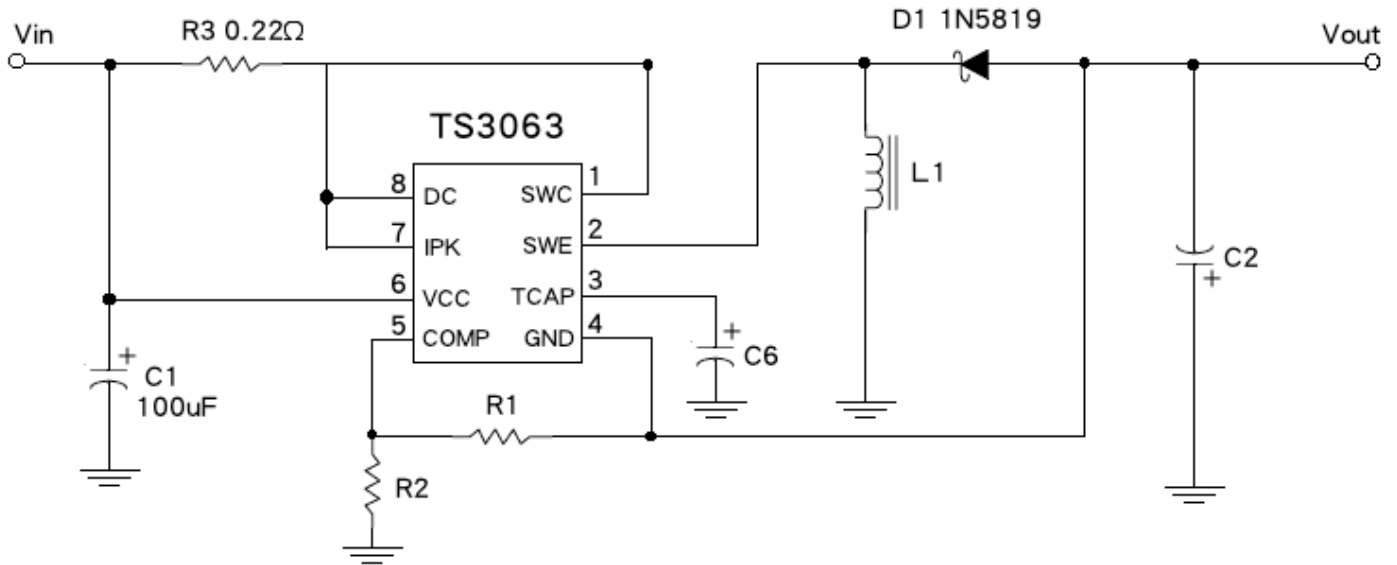

Voltage Inverting Converter

Quick Design Component Selection Table for -5V & -12V Version

-5V Version: R1=1KΩ, R2=3KΩ

L (uH)	Cout (uF)	CT (pF)	Vin (V)	Iin (mA)	Pin (W)	Vout (V)	Iout (A)	Pout (W)	Frequency (KHz)	η (%)
180	470	390	5	171	0.855	-5.147	0.1	0.5147	112	60.2

-12V Version: R1=953Ω, R2=8.2KΩ

L (uH)	Cout (uF)	CT (pF)	Vin (V)	Iin (mA)	Pin (W)	Vout (V)	Iout (A)	Pout (W)	Frequency (KHz)	η (%)
180	470	470	5	409	2.045	-12.044	0.1	1.2044	93	58.9

SOP-8 Mechanical Drawing

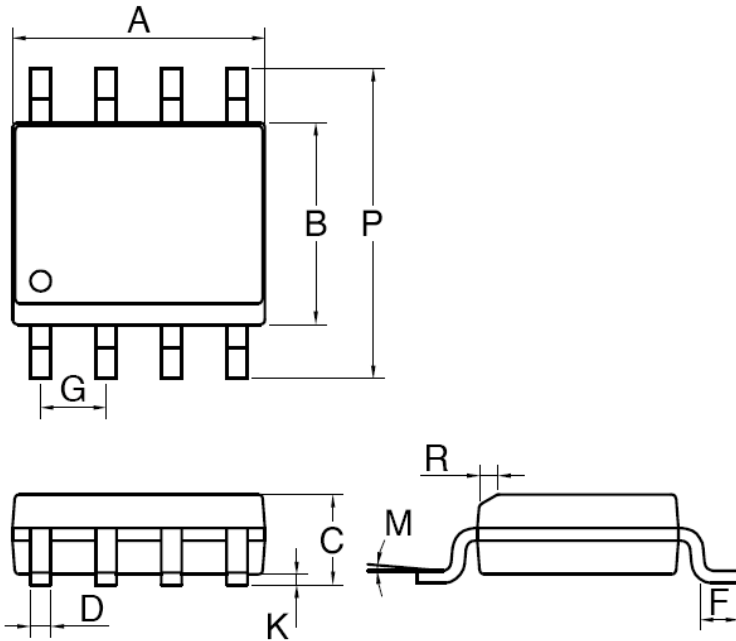

DIM	MILLIMETERS		INCHES	
	MIN	MAX	MIN	MAX.
A	4.80	5.00	0.189	0.196
B	3.80	4.00	0.150	0.157
C	1.35	1.75	0.054	0.068
D	0.35	0.49	0.014	0.019
F	0.40	1.25	0.016	0.049
G	1.27BSC		0.05BSC	
K	0.10	0.25	0.004	0.009
M	0°	7°	0°	7°
P	5.80	6.20	0.229	0.244
R	0.25	0.50	0.010	0.019

Marking Diagram

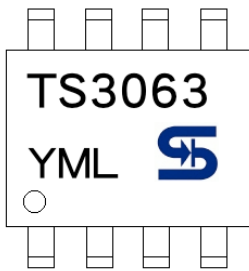

- Y** = Year Code
- M** = Month Code
(**A**=Jan, **B**=Feb, **C**=Mar, **D**=Apr, **E**=May, **F**=Jun, **G**=Jul, **H**=Aug, **I**=Sep, **J**=Oct, **K**=Nov, **L**=Dec)
- L** = Lot Code

MSOP-8 Mechanical Drawing

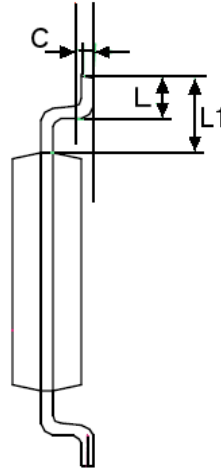
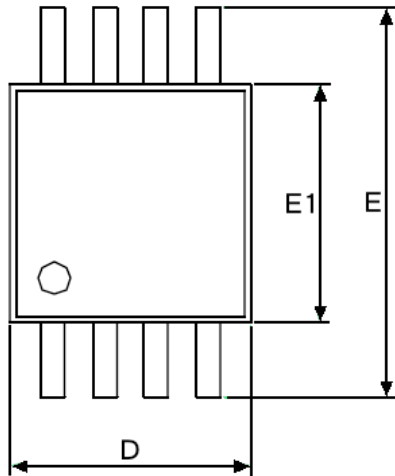

DIM	MSOP-8 DIMENSION			
	MILLIMETERS		INCHES	
	MIN	MAX	MIN	MAX.
A	0.81	1.10	0.032	0.043
A1	0.05	0.15	0.002	0.006
A2	0.76	0.97	0.030	0.038
b	0.28	0.38	0.011	0.015
C	0.13	0.23	0.005	0.009
D	2.90	3.10	0.114	0.122
E	4.70	5.10	0.185	0.201
E1	2.90	3.10	0.114	0.122
e	0.65 (Typ.)		0.026 (Typ.)	
L	0.40	0.66	0.016	0.026
L1	0.85	1.05	0.033	0.041

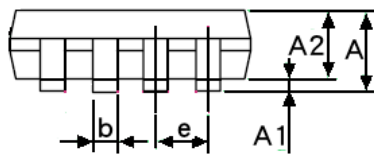

Marking Diagram



- Y** = Year Code
- M** = Month Code
(**A**=Jan, **B**=Feb, **C**=Mar, **D**=Apr, **E**=May, **F**=Jun, **G**=Jul, **H**=Aug, **I**=Sep, **J**=Oct, **K**=Nov, **L**=Dec)
- L** = Lot Code

Notice

Specifications of the products displayed herein are subject to change without notice. TSC or anyone on its behalf, assumes no responsibility or liability for any errors or inaccuracies.

Information contained herein is intended to provide a product description only. No license, express or implied, to any intellectual property rights is granted by this document. Except as provided in TSC's terms and conditions of sale for such products, TSC assumes no liability whatsoever, and disclaims any express or implied warranty, relating to sale and/or use of TSC products including liability or warranties relating to fitness for a particular purpose, merchantability, or infringement of any patent, copyright, or other intellectual property right.

The products shown herein are not designed for use in medical, life-saving, or life-sustaining applications. Customers using or selling these products for use in such applications do so at their own risk and agree to fully indemnify TSC for any damages resulting from such improper use or sale.