

**TRS-5240G / TRS-5240TG / TRS-5240FG / TRS-5240CG / TRS-5240CTG / TRS-5240CFG**  
**5V / 1550 nm / 622 Mbps **RoHS Compliant** Optical Single-Mode Transceiver**

## FEATURES

- | Duplex SC Single Mode Transceiver: TRS-5240G
- | Duplex ST Single Mode Transceiver: TRS-5240TG
- | Duplex FC Single Mode Transceiver: TRS-5240FG
- | 1550 nm DFB LD Transmitter
- | Industry Standard 1 x 9 Footprint
- | Single +5 V Power Supply
- | RoHS Compliant
- | PECL Signal Detection Output: TRS-5240G
- | TTL Signal Detection Output: TRS-5240CG
- | LED Multisourced 1 x 9 Transceiver Interchangeable
- | Wave Solderable and Aqueous Washable
- | Class 1 Laser International Safety Standard IEC-60825 Compliant

## DESCRIPTION

The TRS-5240G series single mode transceivers is low power, high performance module for bi-directional serial optical data communications such as SONET OC-12 / SDH STM-4. This module is designed for single mode fiber and operates at a nominal wavelength of 1550 nm. The transmitter section uses a multiple quantum well 1550 nm DFB laser and is a class 1 laser compliant according to International Safety Standard IEC-60825. The receiver section uses an integrated InGaAs detector preamplifier (IDP) mounted in an optical header and a limiting post-amplifier IC. A PECL logic interface simplifies interface to external circuitry.

## LASER SAFETY

This single mode transceiver is a Class 1 laser product. It complies with IEC-60825 and FDA 21 CFR 1040.10 and 1040.11. The transceiver must be operated within the specified temperature and voltage limits. The optical ports of the module shall be terminated with an optical connector or with a dust plug.

## APPLICATIONS

- | ATM 622 Mbps Links
- | SONET/SDH Equipment Interconnect
- | Fiber Channel 532 Mbps Links

## ORDER INFORMATION

| P/No.     | Bit Rate (Mb/s) | SONET /SDH | Distance (km) | Wavelength (nm) | Voltage (V) | Package      | Temp. (°C) | TX Power (dBm) | RX Sens. (dBm) | RoHS Compliant |
|-----------|-----------------|------------|---------------|-----------------|-------------|--------------|------------|----------------|----------------|----------------|
| TRS-5240G | 622             |            | 40            | 1550 DFB        | 5           | 1X9 SC/ST/FC | 0 to 70    | 0 to -8        | -28            | Yes            |

## Absolute Maximum Ratings

| Parameter             | Symbol | Min | Max | Units | Notes                    |
|-----------------------|--------|-----|-----|-------|--------------------------|
| Storage Temperature   | Tstg   | -40 | 85  | °C    |                          |
| Operating Temperature | Topr   | 0   | 70  | °C    |                          |
| Soldering Temperature | ---    |     | 260 | °C    | 10 seconds on leads only |
| Power Supply Voltage  | Vcc    | 0   | 6   | V     |                          |
| Input Voltage         | ---    | GND | Vcc | V     |                          |
| Output Current        | Iout   | 0   | 30  | mA    |                          |

## Recommended Operating Conditions

| Parameter             | Symbol | Min  | Typ | Max  | Units |
|-----------------------|--------|------|-----|------|-------|
| Power Supply Voltage  | Vcc    | 4.75 | 5   | 5.25 | V     |
| Operating Temperature | Topr   | 0    |     | 70   | °C    |
| Data Rate             |        | 50   | 622 |      | Mb/s  |
| Power Supply Current  | Icc    |      |     | 260  | mA    |

\*\*\*\*\*

| Transmitter Specifications (0°C < Topr < 70°C, 4.75V < Vcc < 5.25V) |  |      |      |       |       |                   |
|---|--|------|------|-------|-------|-------------------|
| Parameter   | Symbol   | Min  | Typ  | Max   | Units | Notes             |
| <b>Optical</b>  |  |      |      |       |       |                   |
| Optical Transmit Power  | P <sub>o</sub>   | -8   | ---  | 0     | dBm   | 1                 |
| Output Center Wavelength  | λ  | 1430 | 1550 | 1600  | nm    |                   |
| Output Spectrum Width   | Δλ   | ---  | ---  | 1     | nm    | -20 dB Width      |
| Side Mode Suppression Ratio   | SMSR   | 30   |      |       | dB    |                   |
| Extinction Ratio  | E <sub>R</sub>   | 10   | ---  | ---   | dB    |                   |
| Output Eye  | Compliant with Bellcore TR-NWT-000253 and ITU recommendation G.957 |      |      |       |       |                   |
| Optical Rise Time   | t <sub>r</sub>   |      |      | 1.2   | ns    | 10% to 90% Values |
| Optical Fall Time   | t <sub>f</sub>   |      |      | 1.2   | ns    | 10% to 90% Values |
| Relative Intensity Noise  | RIN  |      |      | -116  | dB/Hz |                   |
| Total Jitter  | TJ   |      |      | 0.55  | ns    | 2                 |
| <b>Electrical</b>   |  |      |      |       |       |                   |
| Data Input Current – Low  | I <sub>IL</sub>  | -350 |      |       | μA    |                   |
| Data Input Current – High   | I <sub>IH</sub>  |      |      | 350   | μA    |                   |
| Differential Input Voltage  | V <sub>IH</sub> - V <sub>IL</sub>                                  | 300  |      |       | mV    |                   |
| Data Input Voltage – Low  | V <sub>IL</sub> - V <sub>CC</sub>                                  | -2.0 |      | -1.58 | V     | 3                 |
| Data Input Voltage -- High  | V <sub>IH</sub> - V <sub>CC</sub>                                  | -1.1 |      | -0.74 | V     | 3                 |

- Notes: 1. Output power is power coupled into a 9/125 μm single mode fiber.  
 2. Measured with a 2<sup>23</sup>-1 PRBS with 72 ones and 72 zeros.  
 3. These inputs are compatible with 10K, 10KH and 100K ECL and LVPECL inputs.

| Receiver Specifications (0°C < Topr < 70°C, 4.75 V < Vcc < 5.25V) |                                   |      |     |       |       |                         |
|---|-----------------------------------|------|-----|-------|-------|-------------------------|
| Parameter   | Symbol                            | Min  | Typ | Max   | Units | Notes                   |
| <b>Optical</b>  |                                   |      |     |       |       |                         |
| Sensitivity   | ---                               | ---  | --- | -28   | dBm   | 1                       |
| Maximum Input Power   | P <sub>in</sub>                   | -3   |     | ---   | dBm   |                         |
| Signal Detect -- Asserted   | P <sub>a</sub>                    | ---  | --- | -28   | dBm   | Transition: low to high |
| Signal Detect -- Deasserted                                       | P <sub>d</sub>                    | -40  | --- | ---   | dBm   | Transition: high to low |
| Signal detect -- Hysteresis                                       |                                   | 1.0  | --- |       | dB    |                         |
| Wavelength of Operation   |                                   | 1100 | --- | 1600  | nm    |                         |
| <b>Electrical</b>   |                                   |      |     |       |       |                         |
| Data Output Voltage – Low   | V <sub>OL</sub> - V <sub>CC</sub> | -2.0 |     | -1.58 | V     | 2                       |
| Data Output Voltage – High  | V <sub>OH</sub> - V <sub>CC</sub> | -1.1 |     | -0.74 | V     | 2                       |
| Signal Detect Output Voltage -- Low                               | V <sub>OL</sub> - V <sub>CC</sub> | -2.0 |     | -1.58 | V     | TRS-5240G               |
| Signal Detect Output Voltage -- High                              | V <sub>OH</sub> - V <sub>CC</sub> | -1.1 |     | -0.74 | V     |                         |
| Signal Detect Output Voltage -- Low                               | V <sub>SDL</sub>                  |      |     | 0.8   | V     | TRS-5240CG              |
| Signal Detect Output Voltage -- High                              | V <sub>SDH</sub>                  | 2.0  |     |       | V     |                         |

- Notes: 1. Minimum sensitivity and saturation levels at BER1E-10 for a 2<sup>23</sup>-1 PRBS with 72 ones and 72 zeros.  
 2. These outputs are compatible with 10K, 10KH and 100K ECL and LVPECL outputs.

\*\*\*\*\*

## CONNECTION DIAGRAM

|                           |            |          |
|---------------------------|------------|----------|
| Receiver Signal Ground    | 1 (Rx GND) | ○        |
| Receiver Data Out         | 2 (RD+)    | N/C      |
| Receiver Data Out Bar     | 3 (RD-)    |          |
| Signal Detect             | 4 (SD)     |          |
| Receiver Power Supply     | 5 (Rx Vcc) | TOP VIEW |
| Transmitter Power Supply  | 6 (Tx Vcc) |          |
| Transmitter Data In Bar   | 7 (TD-)    |          |
| Transmitter Data In       | 8 (TD+)    | N/C      |
| Transmitter Signal Ground | 9 (Tx GND) | ○        |

| PIN | Symbol | Notes  |
|-----|--------|--|
| 1   | Rx GND | Directly connect this pin to the receiver ground plane     |
| 2   | RD+    | See recommended circuit schematic                          |
| 3   | RD-    | See recommended circuit schematic                          |
| 4   | SD     | Active high on this indicates a received optical signal    |
| 5   | Rx Vcc | +5V dc power for the receiver section                      |
| 6   | Tx Vcc | +5V dc power for the transmitter section                   |
| 7   | TD-    | See recommended circuit schematic                          |
| 8   | TD+    | See recommended circuit schematic                          |
| 9   | Tx GND | Directly connect this plan to the transmitter ground plane |

## RECOMMENDED CIRCUIT SCHEMATIC

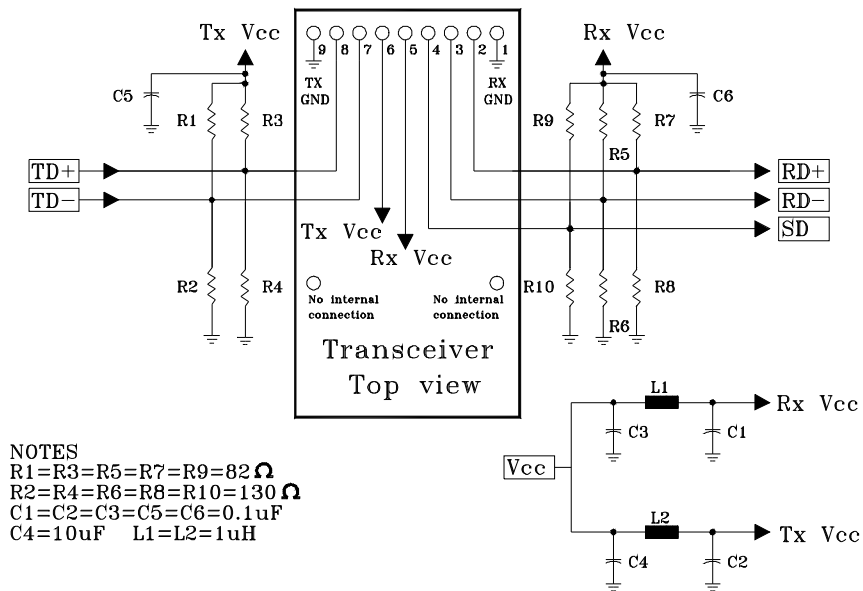

The split-load terminations for ECL signals need to be located at the input of devices receiving those ECL signals. The power supply filtering is required for good EMI performance. Use short tracks from the inductor L1/L2 to the module Rx Vcc and Tx Vcc. A GND plane under the module is required for good EMI and sensitivity performance.

PACKAGE DIAGRAM

Units in mm

1) SC Type

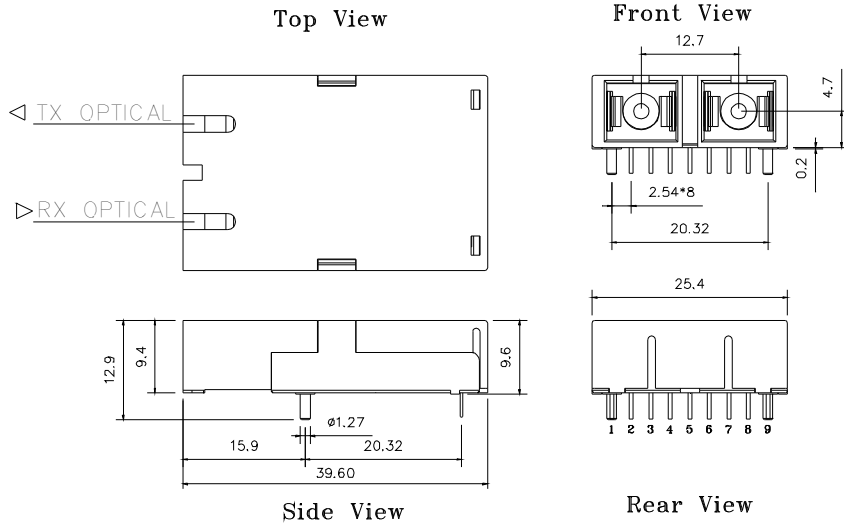

TRS-5240G / TRS-5240CG

2) SC Type With Extended Shielding

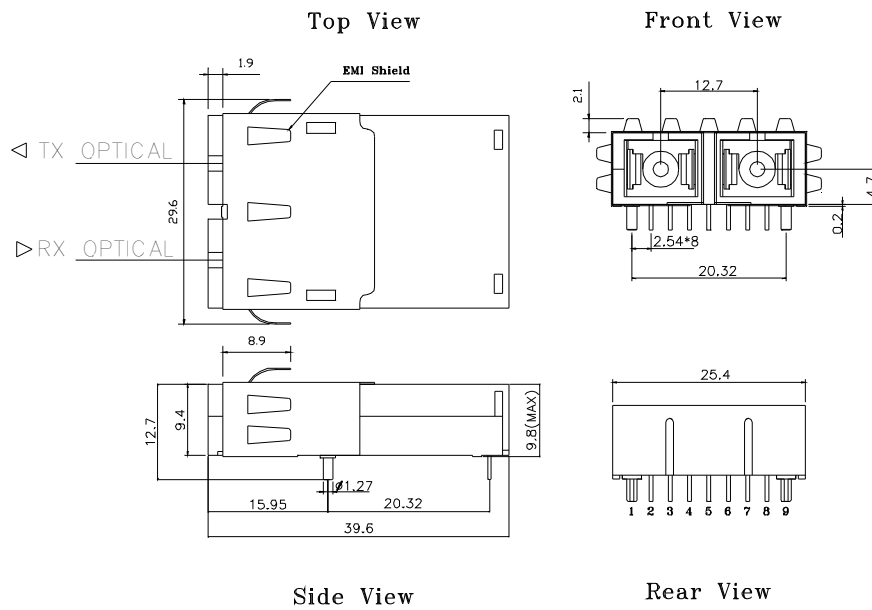

TRS-5240-EMG / TRS-5240C-EMG

### 3) ST Type

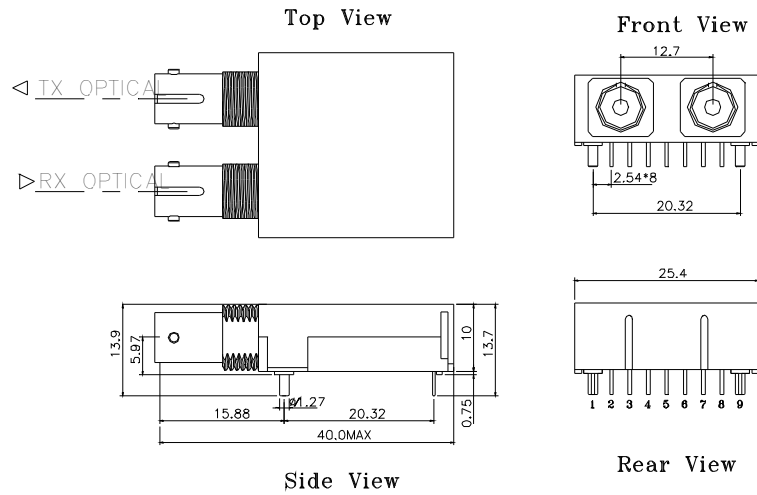

TRS-5240TG / TRS-5240CTG

### 4) FC Type

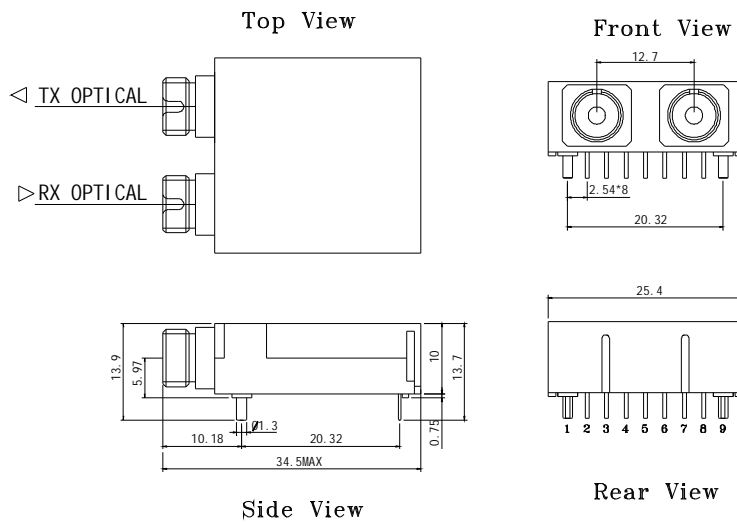

TRS-5240FG / TRS-5240CFG

**Note:** Specifications subject to change without notice.