

STRUCTURE Silicon monolithic integrated circuits

PRODUCT SERIES Stepping motor driver

TYPE **BD6395FP**

FUNCTION • PWM constant current controllable two H bridge driver
 • Full, Half, Quarter step
 • Parallel IN control

○Absolute maximum ratings(Ta=25°C)

Item	Symbol	Limit	Unit
Supply voltage	V _{CC1,2}	-0.2~+36.0	V
Power dissipation	Pd	1.45 ^{*1}	W
		3.47 ^{*2}	W
Input voltage for control pin	V _{IN}	-0.2~+5.5	V
Maximum input voltage for RNF	V _{RNF}	0.5	V
Maximum output current	I _{OUT}	1.5 ^{*3}	A/phase
Operating temperature range	T _{opr}	-25~+75	°C
Storage temperature range	T _{stg}	-55~+150	°C
Junction temperature	T _{jmax}	+150	°C

- *1 glass epoxy board. Derating in done at 11.6mW/°C for operating above Ta=25°C.
- *2 Recommended 4 layers board. Derating in done at 27.8mW/°C or operating above Ta=25°C.
- *3 Do not, however exceed Pd, ASO and Tjmax=150°C.

○Operating conditions (Ta=-25~+75°C)

Item	Symbol	Min	Typ	Max	Unit
Supply voltage	V _{CC1,2}	16	24	28	V
Output current	I _{OUT}	-	1.0	1.2 ^{*4}	A/phase

- *4 Do not, however exceed Pd, ASO.

This product isn't designed for protection against radioactive rays.

Status of this document

The Japanese version of this document is the formal specification.
 A customer may use this translation version only for a reference to help reading the formal version.
 If there are any differences in translation version of this document, formal version takes priority.

○Electrical characteristics (Unless otherwise specified Ta=25°C, VCC0,1,2=24V)

Item	Symbol	Limit			Unit	Conditions
		Min	Typ	Max		
Whole						
Circuit current at standby	I _{CCST}	-	0.4	2.0	mA	PS=L
Circuit current	I _{CC}	-	3.0	10.0	mA	PS=H, VREFX=2V
Control input						
H level input voltage	V _{INH}	2.0	-	-	V	
L level input voltage	V _{INL}	-	-	0.8	V	
Output						
Output ON resistance	R _{ON}	-	1.0	1.3	Ω	I _{OUT} =1.0A, Sum of upper and lower
Output leak current	I _{LEAK}	-	-	10	μA	
Current control						
RNFX input current	I _{RNF}	-40	-20	-	μA	RNFX=0V
VREF input current	I _{VREF}	-1.0	-0.1	-	μA	VREF=0V
VREF input voltage range	V _{REF}	0	-	2.0	V	
Comparator threshold 100%	V _{CTHLL}	0.340	0.400	0.460	V	VREF=2V, I0x=L, I1x=L
Comparator threshold 67%	V _{CTHHL}	0.227	0.267	0.307	V	VREF=2V, I0x=H, I1x=L
Comparator threshold 33%	V _{CTHLH}	0.113	0.133	0.153	V	VREF=2V, I0x=L, I1x=H
Minimum on time	T _{ONMIN}	0.3	0.85	1.40	μsec	R=39kΩ, C=1000pF

○Package outline

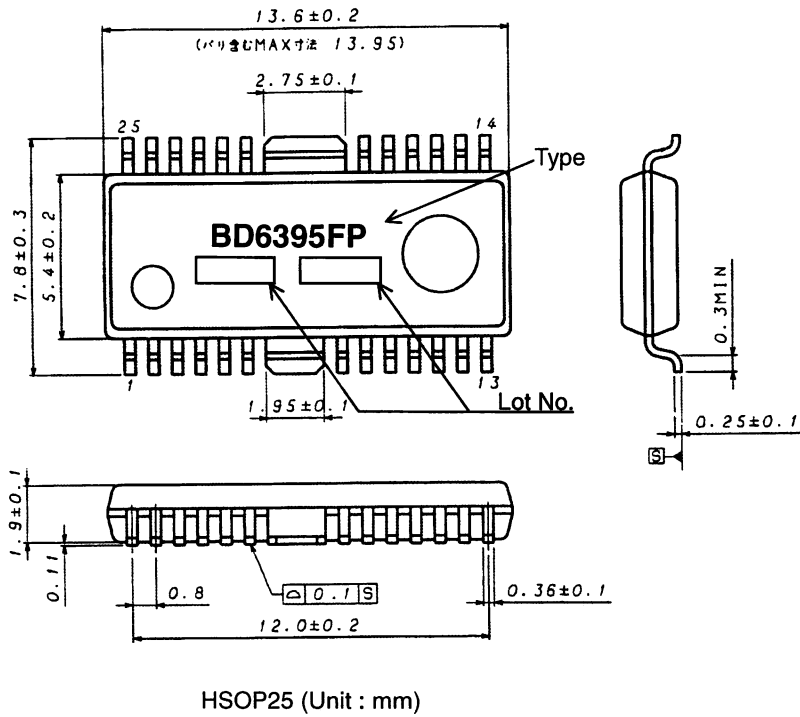

○Block diagram

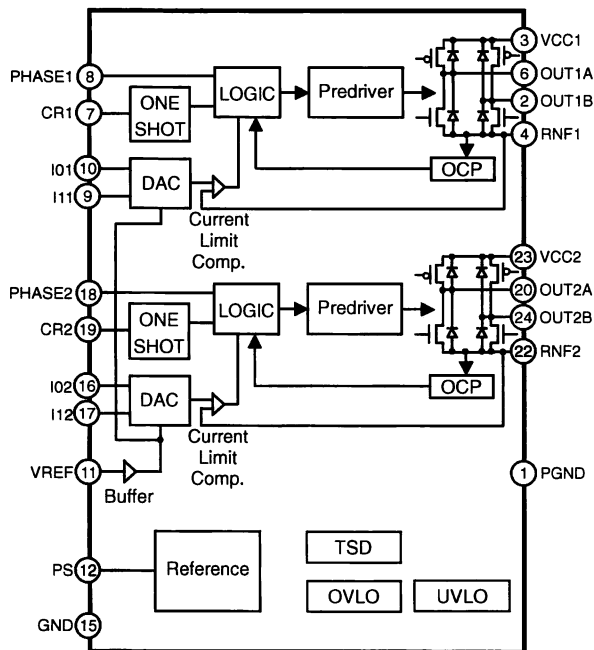

○Pin No. / Pin name

Pin No.	Pin name	Pin No.	Pin name
1	PGND	14	NC
2	OUT1B	15	GND
3	VCC1	16	I02
4	RNF1	17	I12
5	NC	18	PHASE2
6	OUT1A	19	CR2
FIN	FIN	FIN	FIN
7	CR1	20	OUT2A
8	PHASE1	21	NC
9	I11	22	RNF2
10	I01	23	VCC2
11	VREF	24	OUT2B
12	PS	25	NC
13	NC		

NC : Non Connection

○Operation Notes

(1) Absolute maximum ratings

Use of the IC in excess of absolute maximum ratings such as the applied voltage or operating temperature range may result in IC damage. Assumptions should not be made regarding the state of the IC (short mode or open mode) when such damage is suffered. A physical safety measure such as a fuse should be implemented when use of the IC in a special mode where the absolute maximum ratings may be exceeded is anticipated.

(2) Power supply lines

As return of current regenerated by back EMF of motor happens, take steps such as putting capacitor between power supply and GND as an electric pathway for the regenerated current. Be sure that there is no problem with each property such as emptied capacity at lower temperature regarding electrolytic capacitor to decide capacity value. If the connected power supply does not have sufficient current absorption capacity, regenerative current will cause the voltage on the power supply line to rise, which combined with the product and its peripheral circuitry may exceed the absolute maximum ratings. It is recommended to implement a physical safety measure such as the insertion of a voltage clamp diode between the power supply and GND pins.

(3) GND potential

Ensure a minimum GND pin potential in all operating conditions.

(4) Thermal design

Use a thermal design that allows for a sufficient margin in light of the power dissipation (P_d) in actual operating conditions. This IC is equipped with FIN heat dissipation terminals, but dissipation efficiency can be improved by applying heat dissipation treatment in this area. It is important to consider actual usage conditions and to take as large a dissipation pattern as possible.

(5) Actions in strong magnetic field

Use caution when using the IC in the presence of a strong magnetic field as doing so may cause the IC to malfunction.

(6) ASO

When using the IC, set the output transistor so that it does not exceed absolute maximum ratings or ASO.

(7) Thermal shutdown circuit

The IC has a built-in thermal shutdown circuit (TSD circuit). If the chip temperature becomes $T_{jmax}=150^{\circ}\text{C}$, and higher, coil output to the motor will be open. The TSD circuit is designed only to shut the IC off to prevent runaway thermal operation. It is not designed to protect or indemnify peripheral equipment. Do not use the TSD function to protect peripheral equipment.

(8) Ground Wiring Pattern

When using both small signal and large current GND patterns, it is recommended to isolate the two ground patterns, placing a single ground point at the ground potential of application so that the pattern wiring resistance and voltage variations caused by large currents do not cause variations in the small signal ground voltage. Be careful not to change the GND wiring pattern of any external components, either.