

## SUBMINIATURE, HIGH SENSITIVITY PHOTOINTERRUPTER

### \*Features

- 1.Ultra-compact.
- 2.PWB mounting type package.
- 3.High sensing accuracy (Slit width:0.4mm).
- 4.Gap between light emitter and detector:2mm.
- 5.RoHS Compliant.

### \*Applications

- Cassette tape recorders,VCRs.  
 Floppy disk drives.  
 Various microcomputerized control equipment.

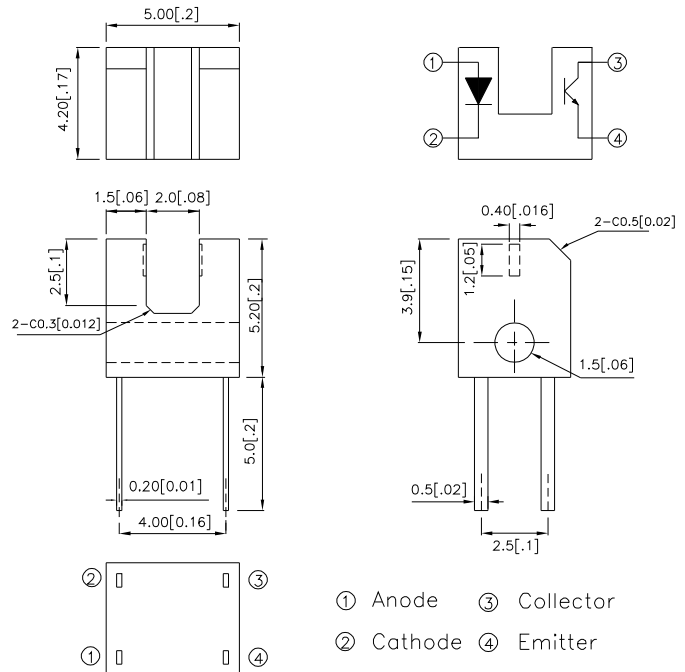

UNIT : MM[INCH]  
 TOLERANCE :  $\pm 0.25[\pm 0.01]$  UNLESS OTHERWISE NOTED.

### \*Absolute Maximum Ratings (T<sub>A</sub>=25°C)

Parameter		Symbol	Rating	Unit
Input	Forward current	I <sub>F</sub>	50	mA
	Reverse voltage	V <sub>R</sub>	6	V
	Power dissipation	P <sub>d</sub>	75	mW
	Peak Forward Current (Pulse Width $\leq 100\mu\text{s}$ , Duty Cycle=1%)	I <sub>FP</sub>	1	A
Output	Collector-emitter voltage	V <sub>CEO</sub>	35	V
	Emitter-collector voltage	V <sub>ECO</sub>	6	V
	Collector current	I <sub>C</sub>	20	mA
	Collector power dissipation	P <sub>C</sub>	75	mW
Operating Temperature		T <sub>opr</sub>	-25~+85	°C
Storage Temperature		T <sub>stg</sub>	-40~+100	°C
Soldering Temperature (1/16 inch from body for 5 seconds)		T <sub>sol</sub>	260	°C

**Electrical / Optical Characteristics at  $T_A=25^{\circ}\text{C}$**

Parameter		Symbol	Conditions	Min.	Typ.	Max.	Unit	
Input	Forward voltage	$V_F$	$I_F=20\text{mA}$	1.0	1.2	1.5	V	
	Reverse current	$I_R$	$V_R=6\text{V}$	-	-	10	$\mu\text{A}$	
	Peak Wavelength	$\lambda_p$	$I_F=20\text{mA}$	-	940	-	nm	
Output	Collector dark current	$I_{CEO}$	$V_{CE}=20\text{V}$	-	-	100	nA	
Transfer Characteristics	Collector-emitter saturation voltage		$V_{CE(SAT)}$	$I_C=40\mu\text{A}, I_F=10\text{mA}$	-	-	0.4	V
	Current transfer ratio		CTR	$V_{CE}=5\text{V}, I_F=5\text{mA}$	-	8	-	%
	Response time	Rise time	$t_r$	$V_{CE}=5\text{V}, I_C=0.1\text{mA}, R_L=1\text{K}\Omega$	-	50	150	$\mu\text{Sec}$
		Fall time	$t_f$		-	50	150	$\mu\text{Sec}$

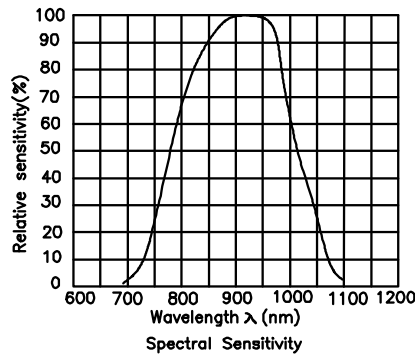

Fig.1 FORWARD CURRENT Vs. FORWARD VOLTAGE

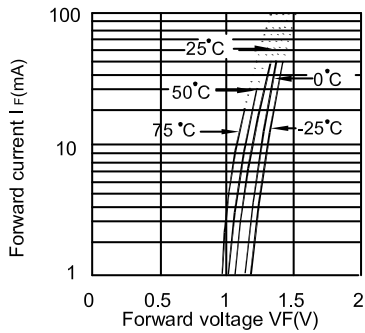

Fig.2 COLLECTOR CURRENT Vs. FORWARD CURRENT

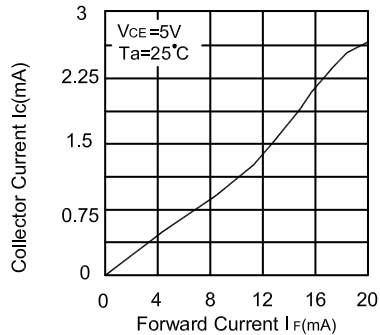

Fig.3 COLLECTOR CURRENT Vs. COLLECTOR-EMITTER VOLTAGE

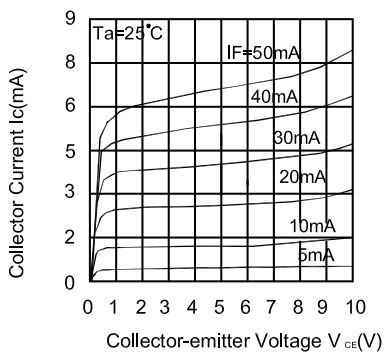

Fig.4 COLLECTOR CURRENT Vs. AMBIENT TEMPERATURE

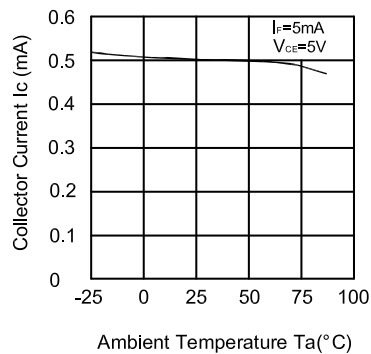

Fig.5 COLLECTOR-EMITTER SATURATION VOLTAGE Vs. AMBIENT TEMPERATURE

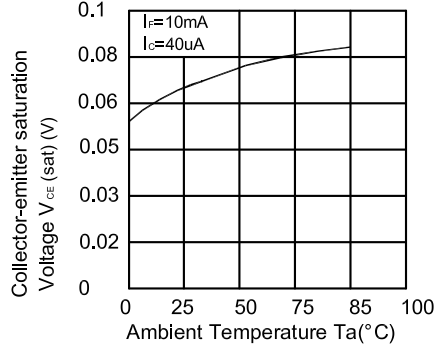

Fig.6 COLLECTOR DARK CURRENT VS. AMBIENT TEMPERATURE

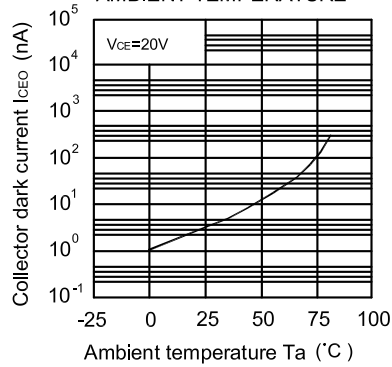

Fig.7 RELATIVE COLLECTOR CURRENT Vs. SHIELD DISTANCE (1)

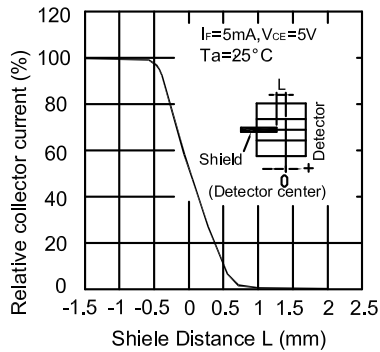

Fig.8 RELATIVE COLLECTOR CURRENT Vs. SHIELD DISTANCE (2)

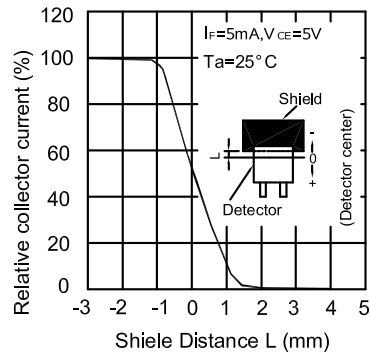
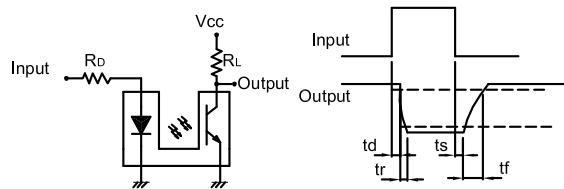
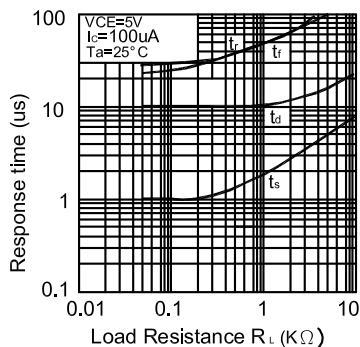
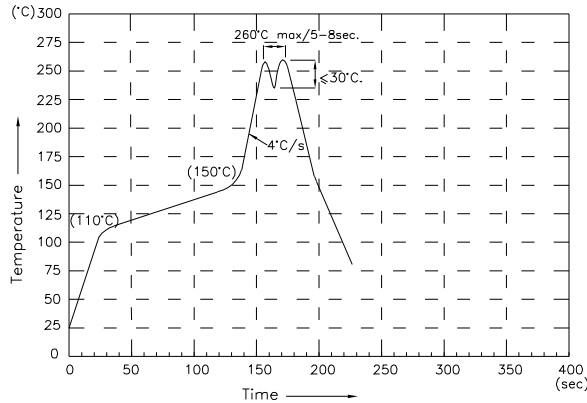

Fig.9 RESPONSE TIME Vs. LOAD RESISTANCE



Test Circuit for Response Time

Wave Soldering Profile For Lead-free Through-hole LED.



NOTES:

- 1.Recommend the wave temperature 245°C~260°C.The maximum soldering temperature should be less than 260°C.
- 2.Do not apply stress on epoxy resins when temperature is over 85 degree°C.
- 3.The soldering profile apply to the lead free soldering (Sn/Cu/Ag alloy).
- 4.No more than once.

**PACKING & LABEL SPECIFICATIONS**

**KRA011**

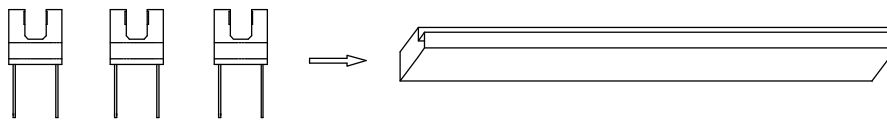

120PCS / IC TUBE

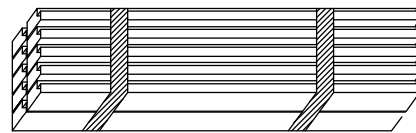
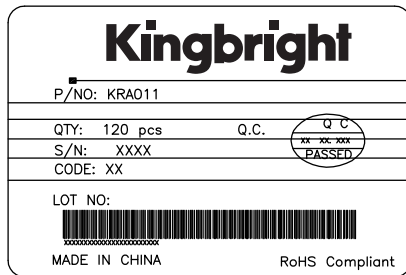

1,200pcs / 10pcs IC TUBE

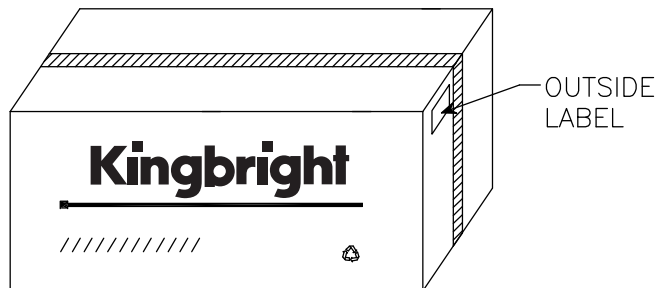

38.4 K / 6# BOX