



PJB75N75

75V N-Channel Enhancement Mode MOSFET

FEATURES

- $R_{DS(ON)}$, V_{GS} @ $10V$, I_{DS} @ $30A=11m\Omega$
- Advanced Trench Process Technology
- High Density Cell Design For Ultra Low On-Resistance
- Specially Designed for Converters and Power Motor Controls
- Fully Characterized Avalanche Voltage and Current
- In compliance with EU RoHS 2002/95/EC directives

MECHANICAL DATA

- Case: D²PAK / TO-263 Molded Plastic
- Terminals : Solderable per MIL-STD-750, Method 2026
- Marking : B75N75

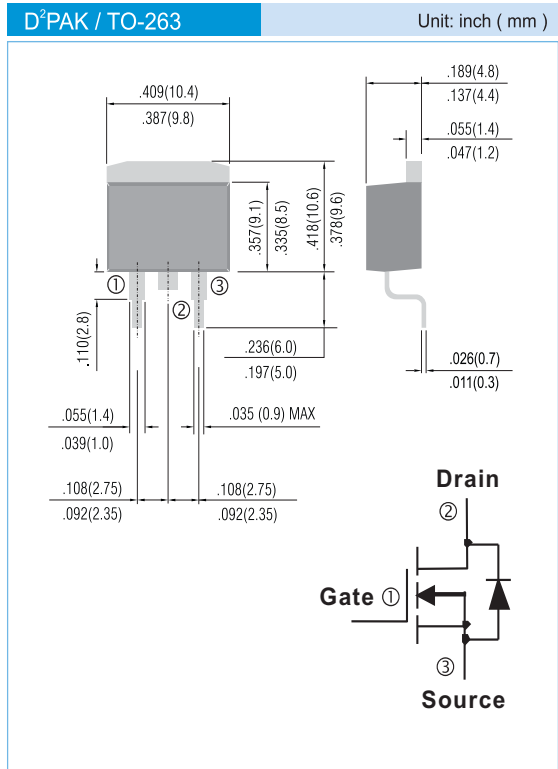

Maximum RATINGS and Thermal Characteristics (T_A=25°C unless otherwise noted)

PARAMETER	Symbol	Limit	Units
Drain-Source Voltage	V _{DS}	75	V
Gate-Source Voltage	V _{GS}	±20	V
Continuous Drain Current	I _D	75	A
Pulsed Drain Current ¹⁾	I _{DM}	350	A
Maximum Power Dissipation	P _D	T _A =25°C 105 T _A =75°C 62.5	W
Operating Junction and Storage Temperature Range	T _J , T _{STG}	-55 to +150	°C
Avalanche Energy with Single Pulse I _{AS} =47A, VDD=37.5V, L=0.3mH	E _{AS}	660	mJ
Junction-to-Case Thermal Resistance	R _{θJC}	1.2	°C/W
Junction-to Ambient Thermal Resistance(PCB mounted) ²	R _{θJA}	62	°C/W

Note: 1. Maximum DC current limited by the package

PAN JIT RESERVES THE RIGHT TO IMPROVE PRODUCT DESIGN, FUNCTIONS AND RELIABILITY WITHOUT NOTICE



PJB75N75

ELECTRICAL CHARACTERISTICS (T_A=25°C unless otherwise noted)

Parameter	Symbol	Test Condition	Min.	Typ.	Max.	Units
Static						
Drain-Source Breakdown Voltage	BV _{DSS}	V _{GS} =0V, I _D =250uA	75	-	-	V
Gate Threshold Voltage	V _{GS(th)}	V _{DS} =V _{GS} , I _D =250uA	1	-	3	V
Drain-Source On-State Resistance	R _{DS(on)}	V _{GS} =10V, I _D =30A	-	8.0	11	mΩ
		V _{GS} =10V, I _D =30A, Tc=125°C	-	-	20	
Zero Gate Voltage Drain Current	I _{DSS}	V _{DS} =75V, V _{GS} =0V	-	-	1	uA
		V _{DS} =75V, V _{GS} =0V, Tc=125°C	-	-	10	
Gate Body Leakage	I _{GSS}	V _{GS} =±20V, V _{DS} =0V	-	-	±100	nA
Forward Transconductance	g _{fS}	V _{DS} >I _{D(ON)} XR _{DS(ON)max} , I _D =15A	20	-	-	S
Dynamic						
Total Gate Charge	Q _g	V _{DS} =30V, I _D =30A V _{GS} =10V	-	83	-	nC
Gate-Source Charge	Q _{gs}		-	8.9	-	
Gate-Drain Charge	Q _{gd}		-	24.3	-	
Turn-On Delay Time	t _{d(on)}	V _{DD} =30V, R _L =15Ω I _D =2A, V _{GEN} =10V R _G =2.5Ω	-	18.2	22	ns
Turn-On Rise Time	t _r		-	15.6	20	
Turn-Off Delay Time	t _{d(off)}		-	70.5	90	
Turn-Off Fall Time	t _f		-	13.8	18	
Input Capacitance	C _{iss}	V _{DS} =25V, V _{GS} =0V f=1.0MHz	-	3150	-	pF
Output Capacitance	C _{oss}		-	300	-	
Reverse Transfer Capacitance	C _{rss}		-	240	-	
Source-Drain Diode						
Max. Diode Forward Current	I _s	-	-	-	75	A
Diode Forward Voltage	V _{SD}	I _s =30A, V _{GS} =0V	-	0.85	1.5	V

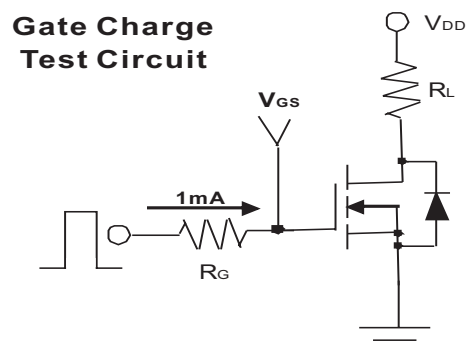
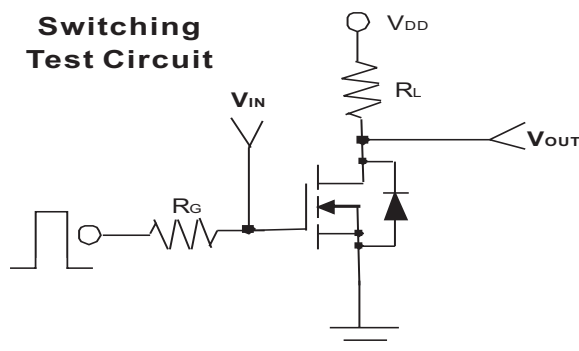



PJB75N75

Typical Characteristics Curves ($T_J=25^\circ\text{C}$, unless otherwise noted)

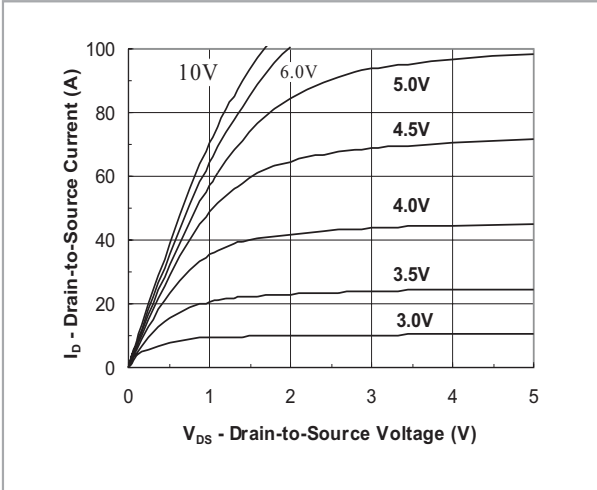

FIG.1- Output Characteristic

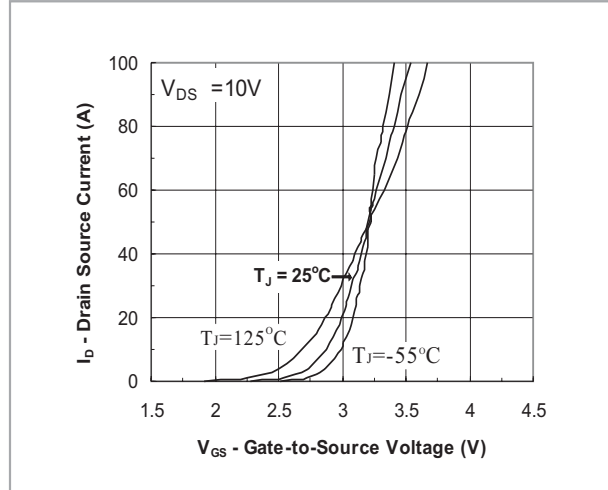

FIG.2- Transfer Characteristic

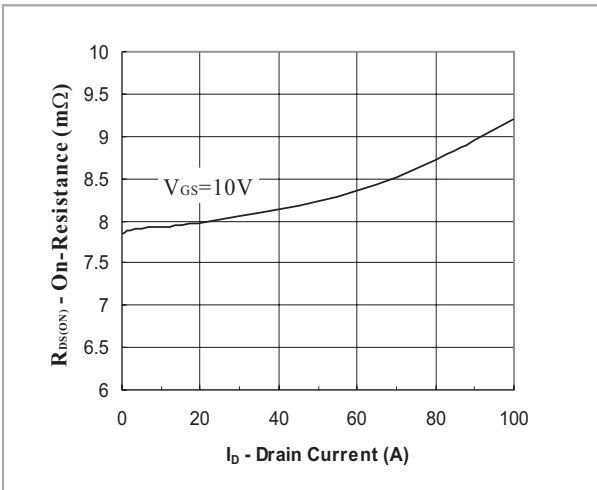

FIG.3- On Resistance vs Drain Current

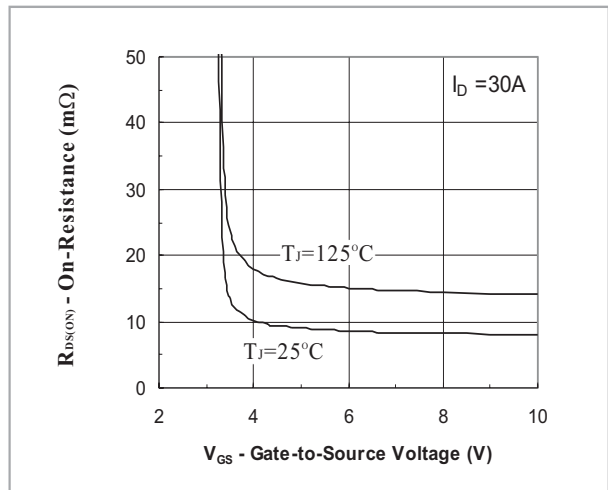

FIG.4- On Resistance vs Gate to Source Voltage

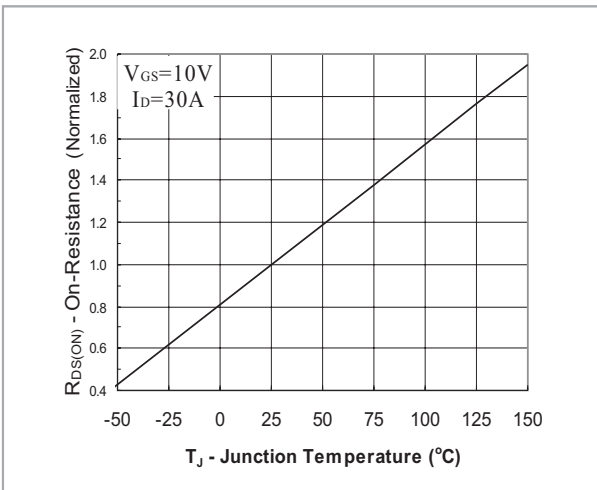

FIG.5- On Resistance vs Junction Temperature

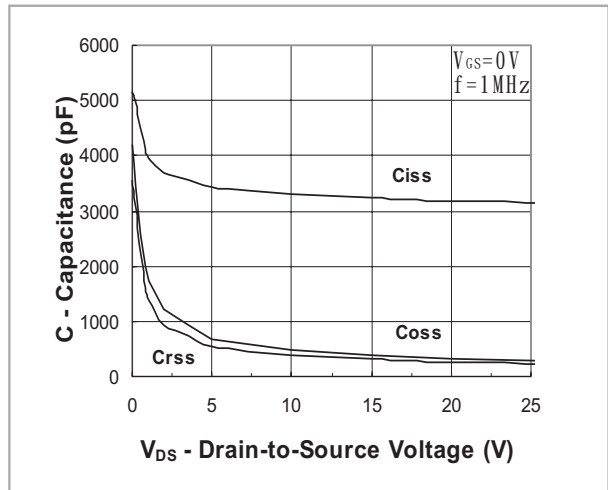
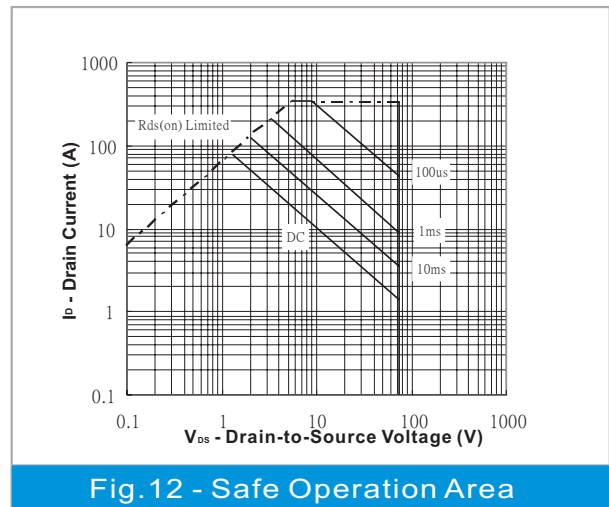
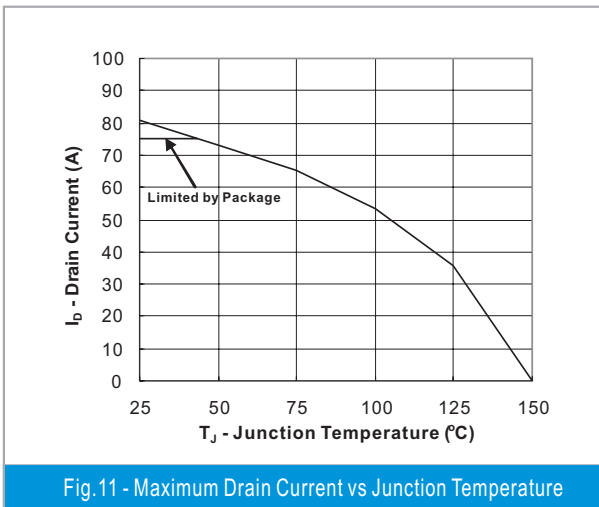
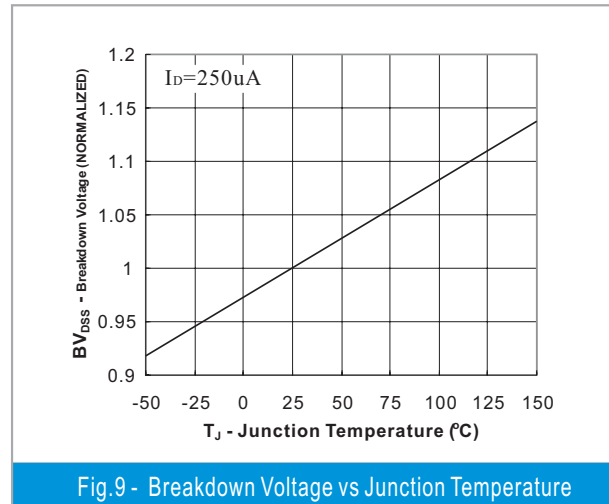
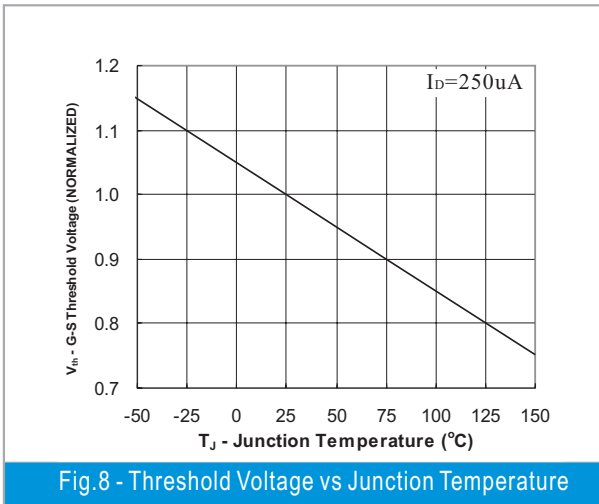
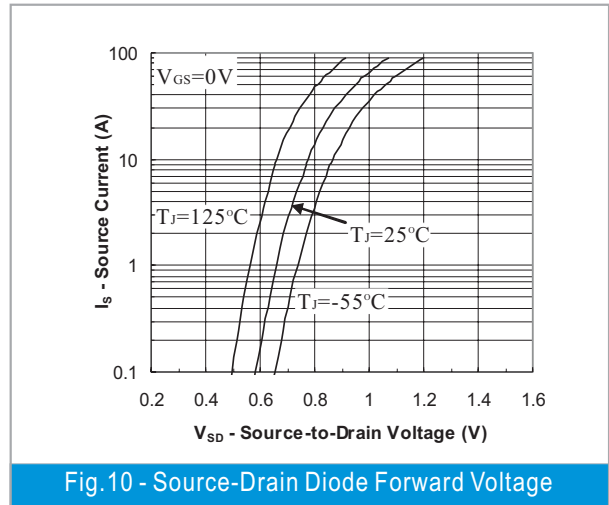
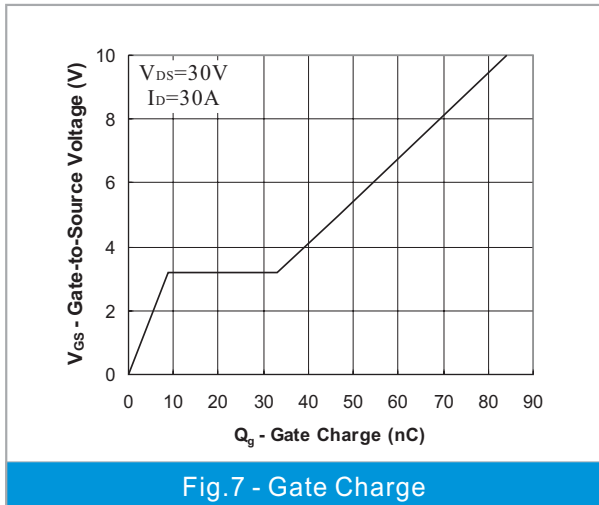

FIG.6 - Capacitance



PJB75N75



LEGAL STATEMENT

Copyright PanJit International, Inc 2007

The information presented in this document is believed to be accurate and reliable. The specifications and information herein are subject to change without notice. Pan Jit makes no warranty, representation or guarantee regarding the suitability of its products for any particular purpose. Pan Jit products are not authorized for use in life support devices or systems. Pan Jit does not convey any license under its patent rights or rights of others.