

XFP Optical Transceivers for 10km 10G Serial Applications IGF Series

IGF-42311J

-5 °C to +70 °C Applications

IGF-42312J

-10 °C to +85 °C Applications

The Bookham IGF-4000 Series optical transceiver modules are high-performance, cost-effective modules for serial optical data communication applications at 10Gb/s. They are designed to provide SONET/SDH (with or without FEC), 10Gb/s Ethernet and 10Gb/s Fibre Channel 10 km compliant links.

The modules are designed for single mode fiber and operate at a nominal wavelength of 1310nm. They incorporate Bookham's exclusive optical packaging platform.

The IGF-42312J version operates over the extended temperature range of -10 °C to 85 °C. This enables higher port density or allows higher chassis temperature in network equipment installations.

The modules aid system hardware engineers in implementing low-cost single mode Physical Media Dependency (PMD) solutions that are protocol transparent. The "hot pluggable" feature built into every module reduces manufacturing cost, inventory costs and allows optical port upgrades at the customer premises. Built-in remote monitoring via digital diagnostics allows user access to static and dynamic data as well as module condition.

The IGF-42311J and IGF-42312J use a DFB laser with an integrated electroabsorption modulator packaged in conjunction with an optical isolator. This design provides for maximum eye opening, minimized jitter generation, and excellent back reflection performance. The transmitter is fully EN/IEC60825-1 Class 1/Class I laser eye safety compliant.



Features:

- Multi-Protocol support:
SONET OC-192 SR-1 / SDH I-64.1
IEEE 802.3 10G Ethernet 10GBASE-LR/LW
10G Fibre Channel
ITU G.709
- 9.95 to 11.3 Gb/s data rates
- Supports 10km link distances
- Hot Pluggable
- Low EMI for high port density
- Low power dissipation
- On board Enhanced Digital Diagnostics providing I2C remote monitoring capability
- XFI Loop-Back Diagnostic
- Integral Signal Conditioning ICs enabling FR4 host board PCB traces up to 8 inches
- Duplex LC connector
- Transmit disable and loss-of-signal functions
- RoHS compliant 

Applications:

- High Port Density Solutions
- SONET / SDH OC-192
- 10Gb/s Gigabit Ethernet Networking
- Telecom, Datacom and Storage-area networking
- Rack-to-rack connectivity
- Client side interconnection
- Fiber to the X aggregation

Absolute maximum ratings

Parameter	Symbol	Min	Max	Units
Storage Temp	T _{stg}	-40	85	°C
Supply voltage ₅	VCC5	0	6	V
Supply voltage ₃	VCC3	0	4.0	V
Supply voltage ₂	VCC2	0	2.2	V
Supply voltage _{E5}	VEE5	-5.2V Not required		V
Data AC volt. differential	Tx+, Tx-	-0.5	2	V _{pp}
Data DC volt	Tx+, Tx-	0	VCC2	V _{pp}

Recommended operating conditions

Parameter	Symbol	Min	Typ	Max	Units	Notes
Baud rate		9.95		11.3	GBd	STM-64/OC-192; G.709; 10 GbE; 10G FC
Supply voltage ₅	VCC5	4.75	5.0	5.25	V	+/- 5%
Supply current ₅	ICC5		300	390	mA	
Supply voltage ₃	VCC3	3.13	3.3	3.47	V	+/- 5%
Supply current ₃	ICC3		230	250	mA	
Supply voltage ₂	VCC2	1.71	1.8	1.89	V	+/- 5%
Supply current ₂	ICC2		0	0	mA	
Supply voltage _{E5}	VEE5		-5.2		V	Not required
Power dissipation	P _w		2.2	2.5	W	IGF-42311J
			2.2	2.7	W	IGF-42312J
Temperature case (IGF-42311J)	T _{s1}	-5		70	°C	
Temperature case (IGF-42312J)	T _{s1}	-10		85	°C	

Please contact sales for special requirements

Operating Specifications – electrical

Parameter	Symbol	Value			Units	Notes
		Min	Typical	Max		
CML input (differential)	V _{TxDiff}	125		700	mVpp	100 ohm differential
CML output (differential)	V _{RxDiff}	360		770	mVpp	100 ohm differential
Rise/Fall time	T _r /T _f	24			Ps	20% - 80%
Loss of signal						
Output voltage high	V _{OH}	2		VCC3+0.3	V	
Output voltage low	V _{OL}	0		0.8	V	
Loss of signal timing						
Assert (off to on)	T _A			100	µs	
Deassert (on to off)	T _D			100	µs	
Tx_disable high	V _{DH}	2		VCC3+0.3	V	
Tx_disable low	V _{DL}	0		0.8	V	
Mod_NR high	V _{NRH}	VCC3-0.7		VCC3+0.3	V	
Mod_NR low	V _{NRL}	0		0.6	V	

Notes:

The IGF-42311J and the IGF-42312J require a baud/64 external reference clock. Reference clock requirements defined by the XFP MSA.

Transmitter operating specifications – optical

Parameter	Symbol	Value			Units	Notes
		Min	Typical	Max		
Center wavelength	λ _c	1290	1310	1330	nm	
Optical transmit power	P _o	-6.0		-1.0	dBm	EOL
Side mode suppression	SMSR	30			dB	
Extinction ratio	ER	6			dB	
Jitter generation	T _{J rms}	Meets Telcordia GR-253 Issue 4 and ITU-T G.825/G.8251			UI	RMS
Jitter generation	T _{Jp-p}				UI	Peak-to-Peak
Transmitter and dispersion penalty	TDP			1.0	dB	10km SMF
Output optical eye	Compliant with Telcordia GR-253 & ITU-T G.691/G.959.1 and IEEE 802.3æ					

Receiver operating specifications – optical

Parameter	Symbol	Value			Units	Notes
		Min	Typical	Max		
Input operating wavelength	λ	1260		1360	nm	
Receiver sensitivity	P _{IN-MIN}			-13.4	dBm	Ave. power at ER=6dB
Maximum input power	P _{IN-MAX}	0.5			dBm	Ave. power
Reflectance				-14	dB	
Loss of Signal						
Loss of Signal Assert (Off to On)	P _A	-32		-19	dBm	
Loss of Signal Deassert (On to Off)	P _D			-15	dBm	
Hysteresis	P _A - P _D	0.5		6	dB	

Electrical pin out

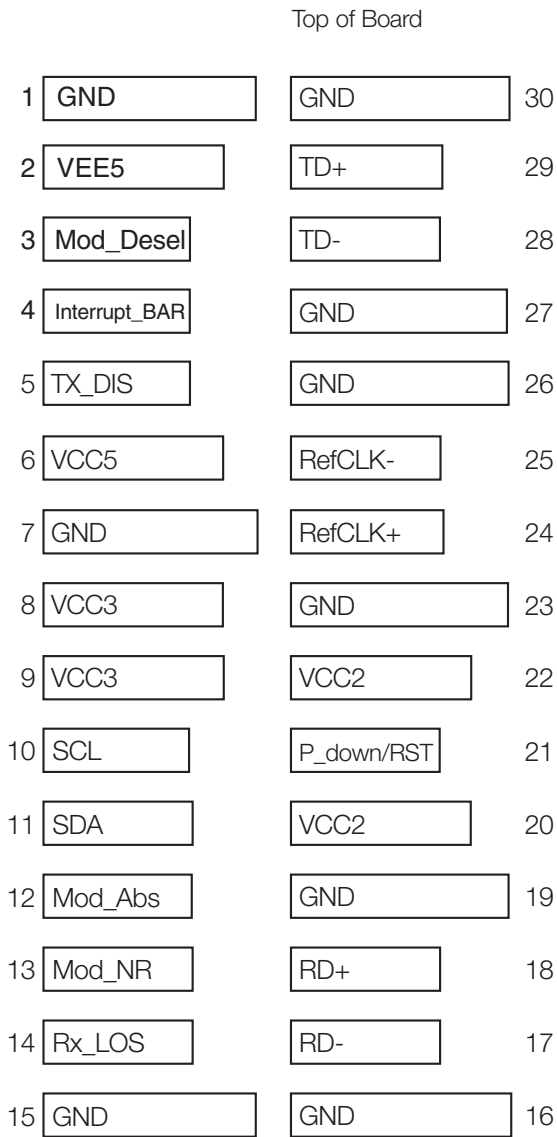

Figure 1: XFP Module Board Pinout & Names

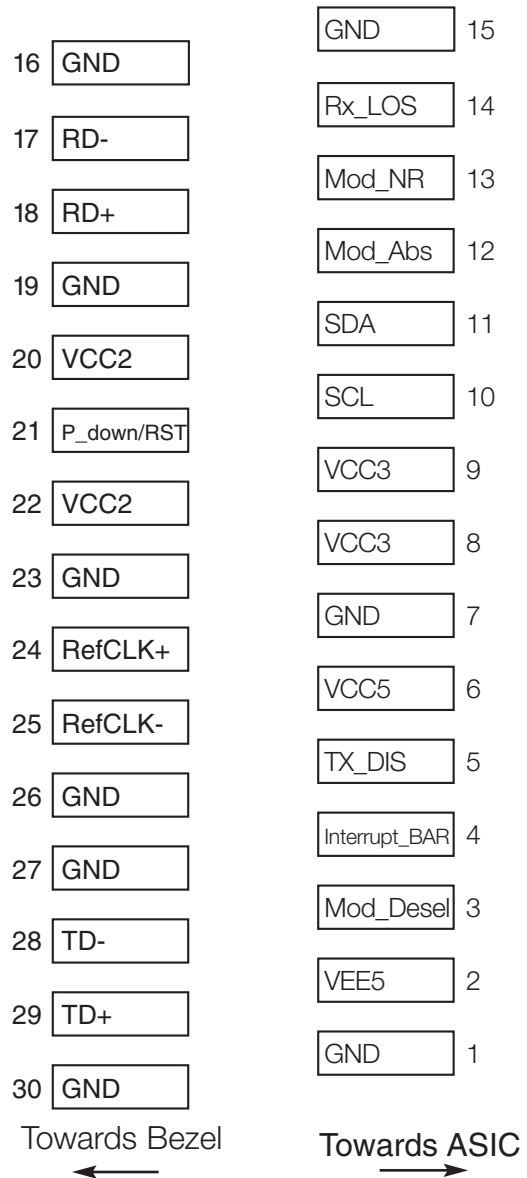

Figure 2: Host PCB XFP Pinout Top View

Pin definitions

Pin #	Logic	Symbol	Function	Plug Seq	Notes
1		GND	Module Ground; Signal Ground	1	1
2		VEE5	Optional -5.2V Power Supply—NOT USED	2	
3	LVTTL-I	Mod_Desel	Module De-select; When held low by host allows the module to respond to 2-wire serial interface commands	3	
4	LVTTL-O	Interrupt_BAR	Interrupt_BAR; Indicates the presence of an important condition that can be read over the two wire interface	3	2
5	LVTTL-I	TX_DIS	Transmitter Disable; Turns Off Transmitter Laser Source	3	
6		VCC5	+5 V Power Supply	2	
7		GND	Module Ground; Signal Ground	1	1
8		VCC3	+3.3 V Power Supply	2	
9		VCC3	+3.3 V Power Supply	2	
10	LVTTL-I	SCA	Two Wire Interface Clock	3	2
11	LVTTL-I/O	SDA	Two Wire Interface Data Line	3	2
12	LVTTL-O	Mod_Abs	Indicates Module Not Present; Grounded in Module	3	2
13	LVTTL-O	Mod_NR	Module Not ready or Indicating Module Operational Fault	3	2
14	LVTTL-O	RX_LOS	Receiver Loss of Signal Indicator	3	2
15		GND	Module Ground; Signal Ground	1	1
16		GND	Module Ground; Signal Ground	1	1
17	CML-O	RD-	Receiver Inverted Data Output	3	
18	CML-O	RD+	Receiver Non-Inverted Data Output	3	
19		GND	Module Ground; Signal Ground	1	1
20		VCC2	+1.8 V Power Supply	2	
21	LVTTL-I	P_down/RST	Power down; When high, places the module in the low power standby mode of less than 1.5 W with 2-wire interface still operational. Reset; The falling edge of P_Down/RST initiates a complete module reset including the 2-wire interface.	3	
22		VCC2	+1.8 V Power Supply	2	
23		GND	Module Ground; Signal Ground	1	1
24	PECL-I	RefCLK+	Reference Clock Non-Inverted Input, AC coupled on Host Board	3	3
25	PECL-I	RefCLK-	Reference Clock Inverted Input, AC coupled on Host Board	3	3
26		GND	Module Ground; Signal Ground	1	1
27		GND	Module Ground; Signal Ground	1	1
28	CML-I	TD-	Transmitter Inverted Data Input	3	
29	CML-I	TD+	Transmitter Non-Inverted Data Input	3	
30		GND	Module Ground; Signal Ground	1	1

Notes:

1. Module ground pins are isolated from the module case and chassis ground within the module.
2. Open Collector should be pulled up with 4.7K-10Kohms to a voltage between 3.15V and 3.6V on the host board.
3. Required for the IGF-42311J and IGF-42312J.

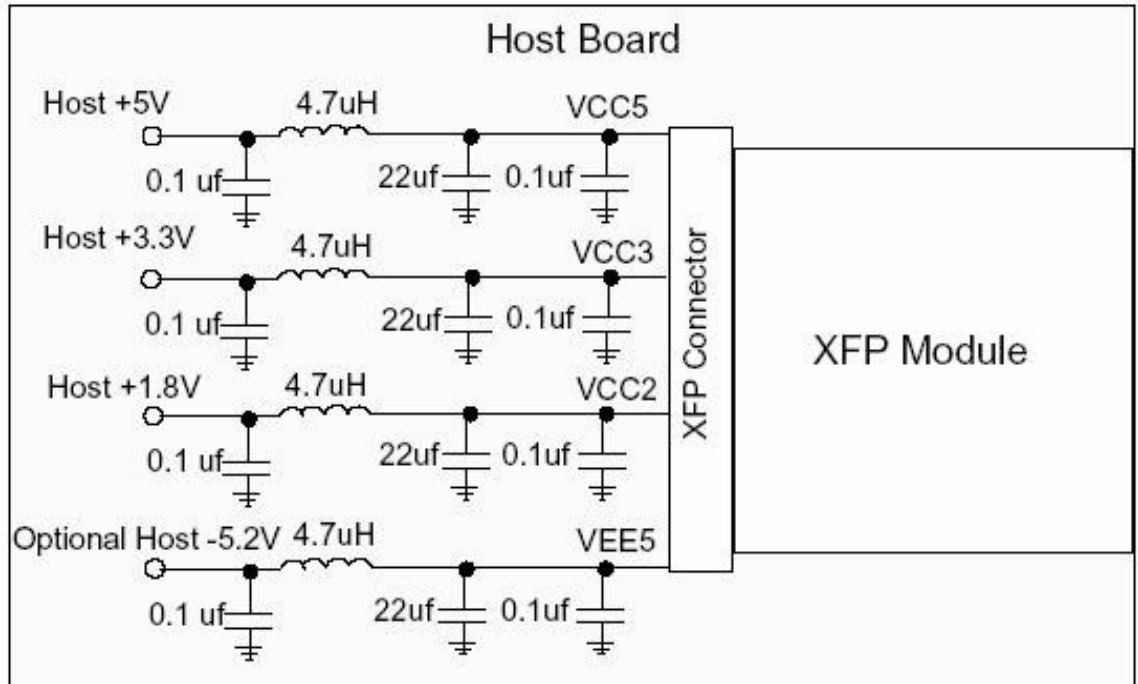

Figure 3. Host Board Supply Filtering

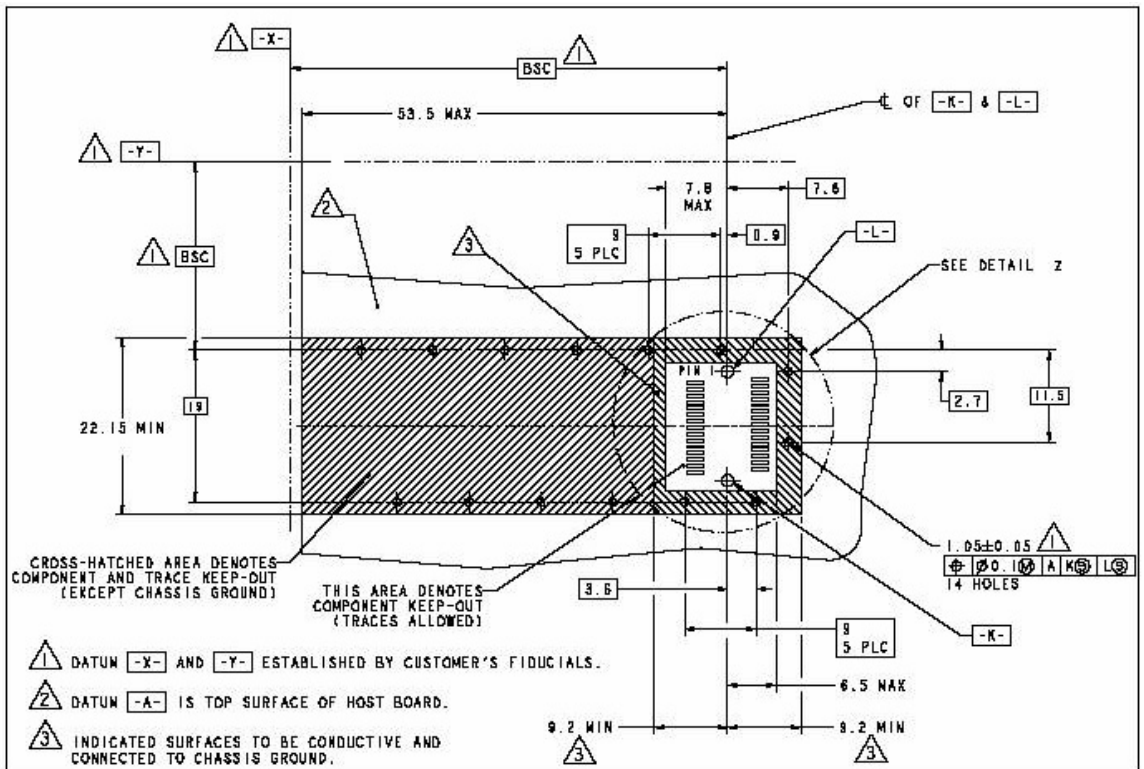

Figure 4. Host Board mechanical layout (mm)

Mechanical interface

The XFP module is a pluggable module with its foundation based on the successful SFP package configuration. It consists of a rectangular package that is approximately 18mm wide and 78mm long. The module interface is a 30 lead connector. The module is inserted into a metal cage assembly. As an option, a heat sink can be clipped to the cage to enhance the cooling of the module.

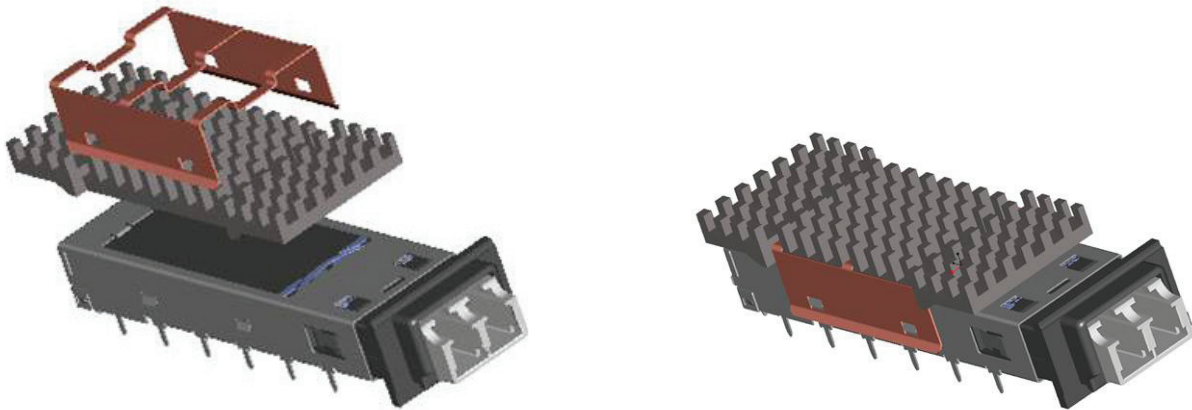

Figure 5. Example of clip-on heat sink

Thermal interface

One of the unique features of the XFP module is that the module cage is designed with the ability to have a thermal heat sink clipped onto the cage. Thus the equipment manufacturer that designs with the XFP can select a heat sink that is optimized for the particular environmental conditions of vertical space above module, air flow, air flow direction and desired pressure drop.

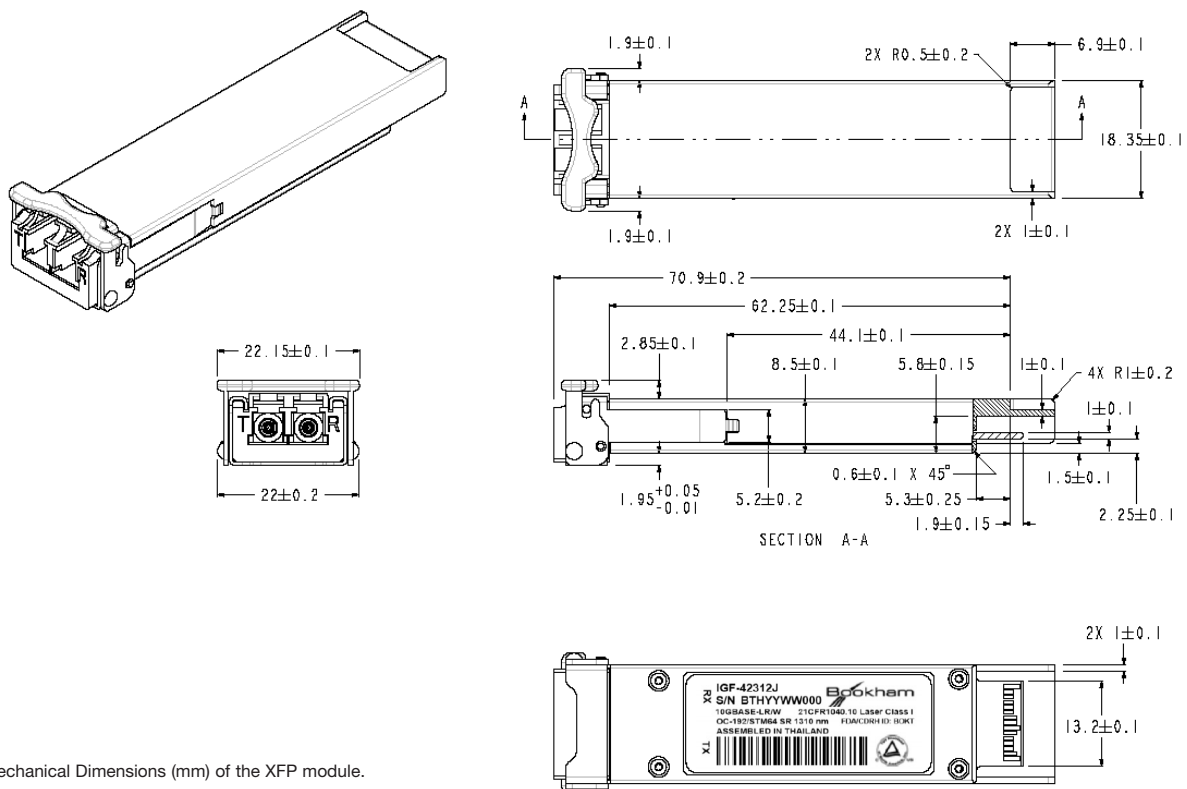

Figure 6. Mechanical Dimensions (mm) of the XFP module.

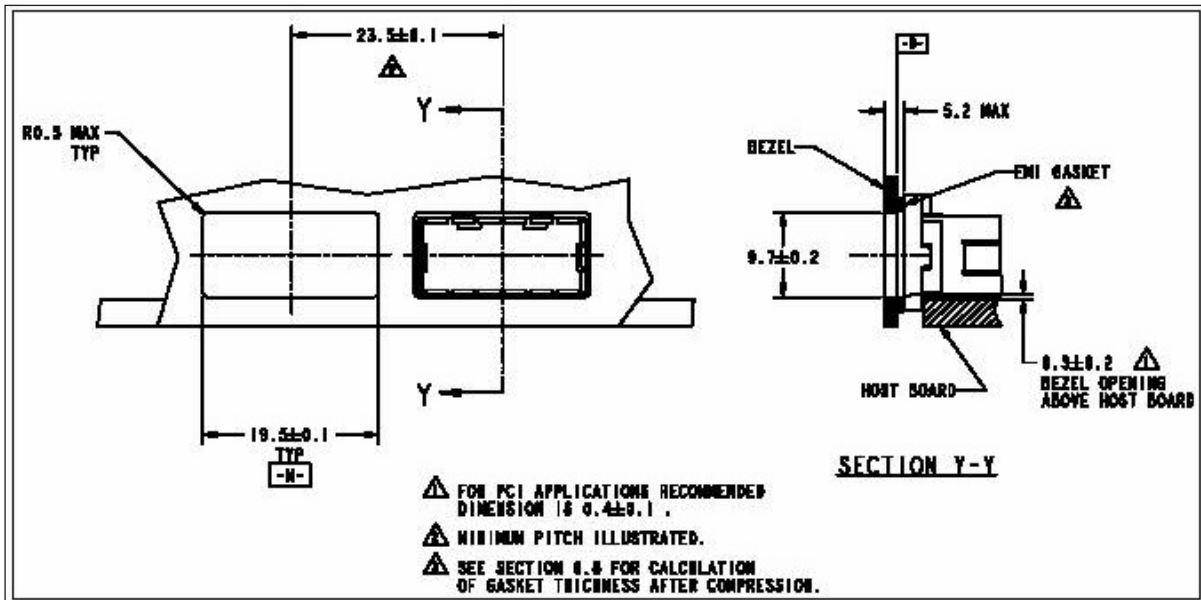

Figure 7. Interface Design with Bezel (mm)

Management Interface

Digital diagnostics is an available interface on all Bookham XFP transceivers. A 2-wire Serial ID interface provides user access to vendor/module identification, customer specific data, link type, static and dynamic monitor hooks, and a check code mechanism for verifying accuracy in the data registers. These “static” and “dynamic” diagnostics allow users to remotely and accurately identify modules and their vendors, make determinations about its compatibility with the system, verify which “Enhanced” diagnostics are supported, and monitor module parameters to determine the module and link condition.

The module’s “Enhanced Digital Diagnostics” features provide real-time monitoring of receiver input power, transmitter power, internal module temperature, laser bias current, and supply voltage parameters.

The 2-wire serial ID interface was originally defined by the GBIC (GigaBit Interface Converter) and SFF-8472 specifications. The XFP MSA (Multi-Source Agreement) document further defined the diagnostics features and introduced a new memory map of the diagnostic information. This interface is a 2-wire interface that allows read-only access to separate memory locations.

The memory location starting at A0h (data address 0 ~ 127) contains the Digital Diagnostic Functions.

The normal 256 Byte I2C address space is divided into lower and upper blocks of 128 Bytes. The lower block of 128 Bytes is always directly available and is used for the diagnostics and

control functions that must be accessed repeatedly. One exception to this is that the standard module identifier Byte defined in the GBIC and SFP is located in Byte 0 of the memory map (in the diagnostics space) to allow software developed for multiple module types to have a common branching decision point. This Byte is repeated in the Serial ID section so that it also appears in the expected relationship to other serial ID bits.

Multiple blocks of memories are available in the upper 128 Bytes of the address space. These are individually addressed through a table select Byte which the user enters into a location in the lower address space. Thus, there is a total available address space of $128 * 256 = 32\text{Kbytes}$ in this upper memory space. The upper address space tables are used for less frequently accessed functions such as serial ID, user writable EEPROM, reserved EEPROM and diagnostics and control spaces for future standards definition, as well as ample space for vendor specific functions. These are allocated as follows:

- Table 01h: Serial ID EEPROM
- Table 02h: User writable EEPROM

The details of each memory space are found in the XFP MSA specification Chapter 5.

Reference Documents:

1. XFP MSA revision 4.0 found at www.xfpmsa.org; April 13, 2004

Regulatory compliance

Bookham IGF-4000 Series 1310nm XFP transceivers are designed to be Class I Laser compliant. They are certified per the following standards:

Feature	Agency	Standard	Certificate/Comments
Laser Safety	FDA/CDRH	Complies with 21 CFR 1040.10 and 1040.11	0520953-00
	TÜV	IEC/EN 60950 IEC/EN 60825-1:1993 +A1:2001 +A2:2001	US-TUVR-2963
		CAN/CSA-60825-1-03	CU72060916 01
Product Safety UL/CSA	TÜV	IEC/EN 60950-1:2001	US-TUVR-2963
		Needle Flame Test to IEC60950-1:2003/A2	2850381_001
		UL 60950-1:2003 CAN/CSA-C22.2 No.60950-1-03	CU72060916 01
ESD	MIL	MIL-STD 883 Method 3015.7	Pass
	IEC	EN55024 / IEC61000-4-2	Class B
EMI	FCC	Emissions 1-40 GHz Class B	Noise frequency range up to 13GHz. Greater than 9dB margin over tested range using PRBS pattern.
	IEC	EN55022 Emissions 30-1000 MHz	Pass Class B
		EN61000-4-3 Immunity 80-1000 MHz 3V/m	Pass Class A

RoHS Compliance



Bookham is fully committed to environment protection and sustainable development and has set in place a comprehensive program for removing polluting and hazardous substances from all of its products. The relevant evidence of RoHS compliance is held as part of our controlled documentation for each of our compliant products. RoHS compliance parts are available to order, please refer to the ordering information section for further details.

Ordering Information:

IGF-42311J

TRX 10G XFP 10KM SR MP4 COM ROHS 5/6

IGF-42312J

TRX 10G XFP 10KM SR MP EXT ROHS 5/6

Contact Information

North America Bookham Worldwide Headquarters

2584 Junction Ave.
San Jose
CA 95134
USA

- Tel: +1 408 919 1500
- Fax: +1 408 919 6083

www.bookham.com
sales@bookham.com

Europe Paignton Office

Brixham Road
Paignton
Devon
TQ4 7BE
United Kingdom

- Tel: +44 (0) 1803 66 2000
- Fax: +44 (0) 1803 66 2801

Asia Shenzhen Office

2 Phoenix Road
Futian Free Trade Zone
Shenzhen 518038
China

- Tel: +86 755 33305888
- Fax: +86 755 33305805
+86 755 33305807

Important Notice

Performance figures, data and any illustrative material provided in this data sheet are typical and must be specifically confirmed in writing by Bookham before they become applicable to any particular order or contract. In accordance with the Bookham policy of continuous improvement specifications may change without notice. The publication of information in this data sheet does not imply freedom from patent or other protective rights of Bookham or others. Further details are available from any Bookham sales representative.