



A25L16P Series

16 Mbit, Low Voltage, Serial Flash Memory

Preliminary

With 85MHz SPI Bus Interface

Document Title

16 Mbit, Low Voltage, Serial Flash Memory With 85MHz SPI Bus Interface

Revision History

<u>Rev. No.</u>	<u>History</u>	<u>Issue Date</u>	<u>Remark</u>
0.0	Initial issue	March 10, 2006	Preliminary
0.1	Change part no. from A25L160P to A25L16P	March 23, 2006	
0.2	Change the frequency to 70 MHz Add the Fast Read Dual Input-Output Mode	March 27, 2006	
0.3	Add QFN 8L (5 x 6mm) package type	April 20, 2006	
0.4	Top or bottom boot block configuration available	December 5, 2006	
0.5	Change the frequency to 85 MHz Remove the REMS mode Correct the A25LPT memory organization of Table 2-1 Reduce the options of protected area size to all sectors protected and all sectors unprotected Modify the lcc ₁ and lcc ₃ of Table 10 Modify the tw and t _{BE} of Table 11	February 6, 2007	
0.6	Add transient voltage (<20ns) on any pin to ground potential spec.	April 24, 2007	



A25L16P Series

16 Mbit, Low Voltage, Serial Flash Memory

Preliminary

With 85MHz SPI Bus Interface

FEATURES

- 16 Mbit of Flash Memory
- Flexible Sector Architecture (4/4/8/16/32)KB/64x31 KB
- Bulk Erase (16 Mbit) in 20s (typical)
- Sector Erase (512 Kbit) in 1s (typical)
- Page Program (up to 256 Bytes) in 1.5ms (typical)
- 2.7 to 3.6V Single Supply Voltage
- SPI Bus Compatible Serial Interface
- 85MHz Clock Rate (maximum)
- Fast Read Dual Operation Instruction (3Bh/BBh)
- Deep Power-down Mode 1μA (typical)
- Top or Bottom Boot Block Configuration Available
- Electronic Signature
 - JEDEC Standard Two-Byte Signature (2015h, Bottom; or 2025, Top)
 - RES Instruction, One-Byte, Signature (14h)
- Package Options
 - 8-pin SOP (209mil), 16-pin SOP, or 8-pin QFN
 - All Pb-free (Lead-free) products are ROHS complaint

GENERAL DESCRIPTION

The A25L16P is a 16 Mbit (2M x 8) Serial Flash Memory, with advanced write protection mechanisms, accessed by a high speed SPI-compatible bus.

The memory can be programmed 1 to 256 bytes at a time, using the Page Program instruction.

The memory is organized as 32 sectors, each containing 256 pages. Each page is 256 bytes wide. Thus, the whole memory can be viewed as consisting of 8192 pages, or 2,097,152 bytes.

The whole memory can be erased using the Bulk Erase instruction, or a sector at a time, using the Sector Erase instruction.

Pin Configurations

■ SO8 Connections

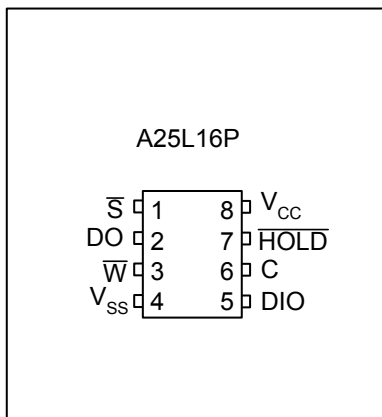

■ SO16 Connections

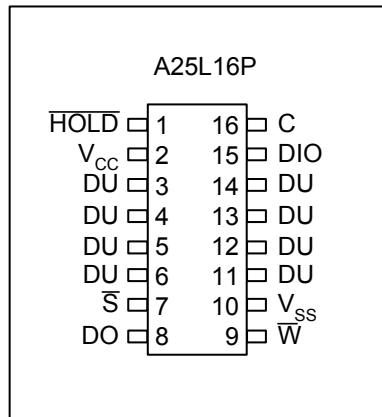

■ QFN8 Connections

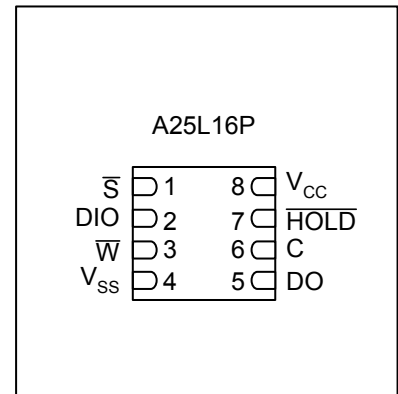

Note:
DU = Do not Use

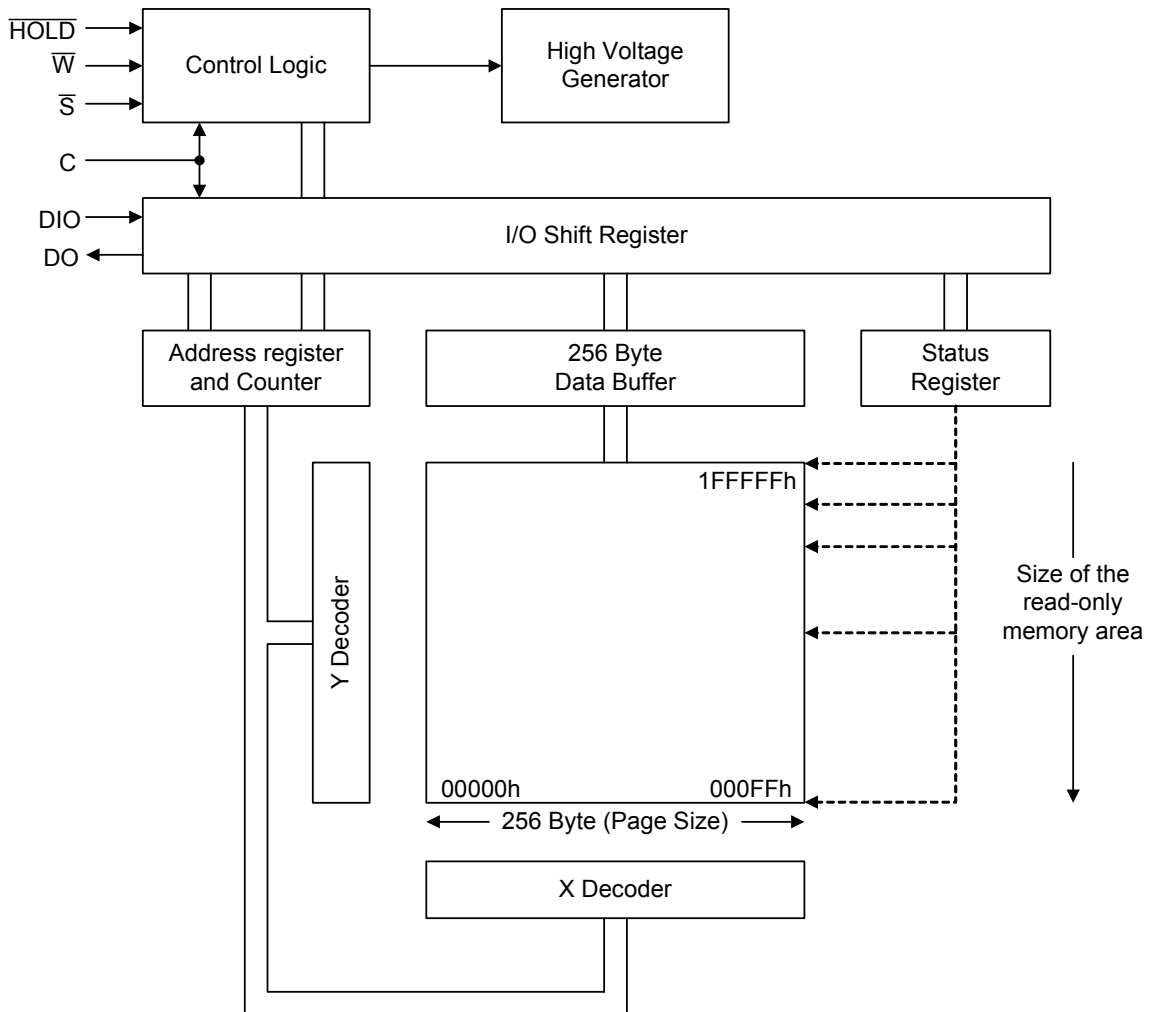
Block Diagram

Pin Descriptions

Pin No.	Description
C	Serial Clock
DIO	Serial Data Input ¹
DO	Serial Data Output ²
\overline{S}	Chip Select
\overline{W}	Write Protect
\overline{HOLD}	Hold
V _{cc}	Supply Voltage
V _{ss}	Ground

Notes:

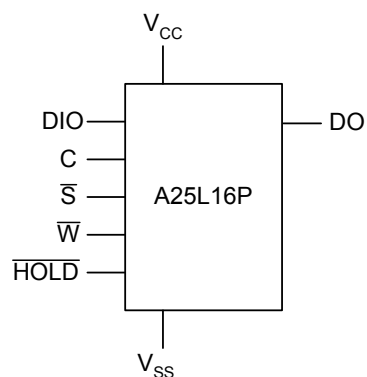
1. The DIO is also used as an output pin when the Fast Read Dual Output instruction and the Fast Read Dual Input-Output instruction are executed.
2. The DO is also used as an input pin when the Fast Read Dual Input-Output instruction is executed.

Logic Symbol

SIGNAL DESCRIPTION

Serial Data Output (DO). This output signal is used to transfer data serially out of the device. Data is shifted out on the falling edge of Serial Clock (C).

The DO pin is also used as an input pin when the Fast Read Dual Input-Output Function is executed.

Serial Data Input / Output (DIO). This input signal is used to transfer data serially into the device. It receives instructions, addresses, and the data to be programmed. Values are latched on the rising edge of Serial Clock (C).

The DIO pin is also used as an output pin when the Fast Read Dual Output function and Fast Read Dual Input-Output function are executed.

Serial Clock (C). This input signal provides the timing of the serial interface. Instructions, addresses, or data present at Serial Data Input (DIO) are latched on the rising edge of Serial Clock (C). Data on Serial Data Output (DO) changes after the falling edge of Serial Clock (C).

Chip Select (\bar{S}). When this input signal is High, the device is deselected and Serial Data Output (DO) is at high impedance. Unless an internal Program, Erase or Write

Status Register cycle is in progress, the device will be in the Standby mode (this is not the Deep Power-down mode). Driving Chip Select (\bar{S}) Low enables the device, placing it in the active power mode.

After Power-up, a falling edge on Chip Select (\bar{S}) is required prior to the start of any instruction.

Hold (HOLD). The Hold (HOLD) signal is used to pause any serial communications with the device without deselecting the device.

During the Hold condition, the Serial Data Output (DO) is high impedance, and Serial Data Input (DIO) and Serial Clock (C) are Don't Care. To start the Hold condition, the device must be selected, with Chip Select (\bar{S}) driven Low.

Write Protect (\bar{W}). The main purpose of this input signal is to freeze the size of the area of memory that is protected against program or erase instructions (as specified by the values in the BP2, BP1 and BP0 bits of the Status Register).

SPI MODES

These devices can be driven by a microcontroller with its SPI peripheral running in either of the two following modes:

- CPOL=0, CPHA=0
- CPOL=1, CPHA=1

For these two modes, input data is latched in on the rising edge of Serial Clock (C), and output data is available from

the falling edge of Serial Clock (C).

The difference between the two modes, as shown in Figure 2, is the clock polarity when the bus master is in Stand-by mode and not transferring data:

- C remains at 0 for (CPOL=0, CPHA=0)
- C remains at 1 for (CPOL=1, CPHA=1)

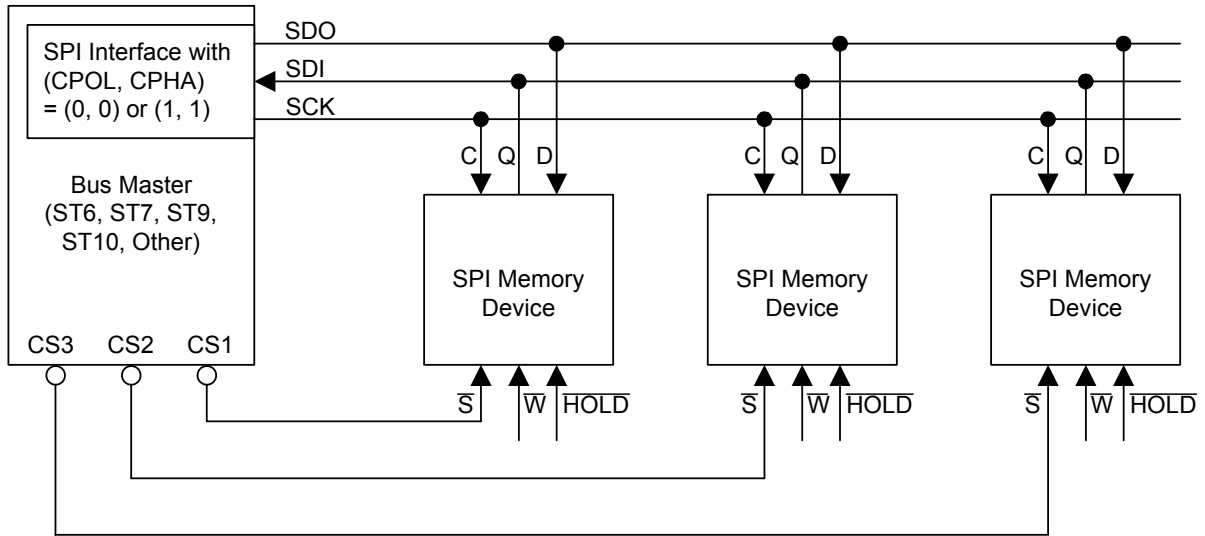
Figure 1. Bus Master and Memory Devices on the SPI Bus

Note: The Write Protect (\overline{W}) and Hold (\overline{HOLD}) signals should be driven, High or Low as appropriate.

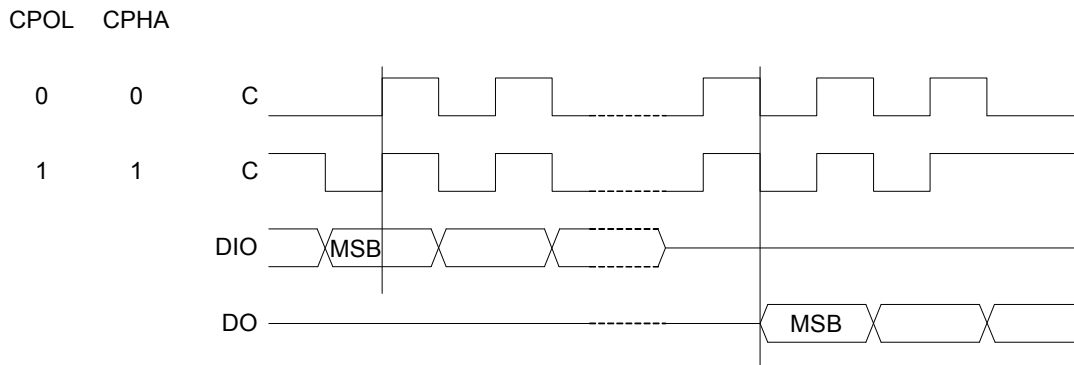
Figure 2. SPI Modes Supported

OPERATING FEATURES

Page Programming

To program one data byte, two instructions are required: Write Enable (WREN), which is one byte, and a Page Program (PP) sequence, which consists of four bytes plus data. This is followed by the internal Program cycle (of duration t_{PP}).

To spread this overhead, the Page Program (PP) instruction allows up to 256 bytes to be programmed at a time (changing bits from 1 to 0), provided that they lie in consecutive addresses on the same page of memory.

Sector Erase and Bulk Erase

The Page Program (PP) instruction allows bits to be reset from 1 to 0. Before this can be applied, the bytes of memory need to have been erased to all 1s (FFh). This can be achieved, a sector at a time, using the Sector Erase (SE) instruction, or throughout the entire memory, using the Bulk Erase (BE) instruction. This starts an internal Erase cycle (of duration t_{SE} or t_{BE}).

The Erase instruction must be preceded by a Write Enable (WREN) instruction.

Polling During a Write, Program or Erase Cycle

A further improvement in the time to Write Status Register (WRSR), Program (PP) or Erase (SE or BE) can be achieved by not waiting for the worst case delay (t_w , t_{PP} , t_{SE} , or t_{BE}). The Write In Progress (WIP) bit is provided in the Status Register so that the application program can monitor its value, polling it to establish when the previous Write cycle, Program cycle or Erase cycle is complete.

Active Power, Stand-by Power and Deep Power-Down Modes

When Chip Select (\bar{S}) is Low, the device is enabled, and in the Active Power mode.

When Chip Select (\bar{S}) is High, the device is disabled, but could remain in the Active Power mode until all internal cycles have completed (Program, Erase, Write Status Register). The device then goes in to the Stand-by Power mode. The device consumption drops to I_{CC1} .

The Deep Power-down mode is entered when the specific instruction (the Enter Deep Power-down Mode (DP) instruction) is executed. The device consumption drops further to I_{CC2} . The device remains in this mode until another specific instruction (the Release from Deep Power-down Mode and Read Electronic Signature (RES) instruction) is executed.

All other instructions are ignored while the device is in the Deep Power-down mode. This can be used as an extra software protection mechanism, when the device is not in active use, to protect the device from inadvertent Write, Program or Erase instructions.

Status Register

The Status Register contains a number of status and control bits that can be read or set (as appropriate) by specific instructions.

WIP bit. The Write In Progress (WIP) bit indicates whether the memory is busy with a Write Status Register, Program or Erase cycle.

WEL bit. The Write Enable Latch (WEL) bit indicates the status of the internal Write Enable Latch, **BP2**, **BP1**, and **BP0** bits. The Block Protect (BP2, BP1, BP0) bits are non-volatile. They define the size of the area to be software protected against Program and Erase instructions.

SRWD bit. The Status Register Write Disable (SRWD) bit is operated in conjunction with the Write Protect (\bar{W}) signal. The Status Register Write Disable (SRWD) bit and Write Protect (\bar{W}) signal allow the device to be put in the Hardware Protected mode. In this mode, the non-volatile bits of the Status Register (SRWD, BP2, BP1, BP0) become read-only bits.

Protection Modes

The environments where non-volatile memory devices are used can be very noisy. No SPI device can operate correctly in the presence of excessive noise. To help combat this, the A25L16P boasts the following data protection mechanisms:

- Power-On Reset and an internal timer (t_{PUW}) can provide protection against inadvertent changes while the power supply is outside the operating specification.
- Program, Erase and Write Status Register instructions are checked that they consist of a number of clock pulses that is a multiple of eight, before they are accepted for execution.
- All instructions that modify data must be preceded by a Write Enable (WREN) instruction to set the Write Enable Latch (WEL) bit. This bit is returned to its reset state by the following events:
 - Power-up
 - Write Disable (WRDI) instruction completion
 - Write Status Register (WRSR) instruction completion
 - Page Program (PP) instruction completion
 - Sector Erase (SE) instruction completion
 - Bulk Erase (BE) instruction completion
- The Write Protect (\bar{W}) signal allows the Block Protect (BP2, BP1, BP0) bits and Status Register Write Disable (SRWD) bit to be protected. This is the Hardware Protected Mode (HPM).
- In addition to the low power consumption feature, the Deep Power-down mode offers extra software protection from inadvertent Write, Program and Erase instructions, as all instructions are ignored except one particular instruction (the Release from Deep Power-down instruction).

Table 1. Protected Area Sizes
A25L16PT Top Boot Block

Status Register Content			Memory Content	
BP2 Bit	BP1 Bit	BP0 Bit	Protected Area	Unprotected Area
0	0	0	none	All sectors ¹ (32 sectors: 0 to 31)
1	1	1	All sectors (32 sectors: 0 to 31)	none

Note: 1. The device is ready to accept a Bulk Erase instruction if, and only if, all Block Protect (BP2, BP1, BP0) are 0.
 2. The sector 31 include sector 31-0, sector 31-1, sector 31-2, sector 31-3 and sector 31-4.

A25L16PU Bottom Boot Block

Status Register Content			Memory Content	
BP2 Bit	BP1 Bit	BP0 Bit	Protected Area	Unprotected Area
0	0	0	none	All sectors ¹ (32 sectors: 0 to 31)
1	1	1	All sectors (32 sectors: 0 to 31)	none

Note: 1. The device is ready to accept a Bulk Erase instruction if, and only if, all Block Protect (BP2, BP1, BP0) are 0.
 2. The sector 0 include sector 0-0, sector 0-1, sector 0-2, sector 0-3 and sector 0-4.

Hold Condition

The Hold ($\overline{\text{HOLD}}$) signal is used to pause any serial communications with the device without resetting the clocking sequence. However, taking this signal Low does not terminate any Write Status Register, Program or Erase cycle that is currently in progress.

To enter the Hold condition, the device must be selected, with Chip Select ($\overline{\text{S}}$) Low.

The Hold condition starts on the falling edge of the Hold ($\overline{\text{HOLD}}$) signal, provided that this coincides with Serial Clock (C) being Low (as shown in Figure 3.).

The Hold condition ends on the rising edge of the Hold ($\overline{\text{HOLD}}$) signal, provided that this coincides with Serial Clock (C) being Low.

If the falling edge does not coincide with Serial Clock (C) being Low, the Hold condition starts after Serial Clock (C) next goes Low. Similarly, if the rising edge does not coincide

with Serial Clock (C) being Low, the Hold condition ends after Serial Clock (C) next goes Low. This is shown in Figure 3.

During the Hold condition, the Serial Data Output (DO) is high impedance, and Serial Data Input (DIO) and Serial Clock (C) are Don't Care.

Normally, the device is kept selected, with Chip Select ($\overline{\text{S}}$) driven Low, for the whole duration of the Hold condition. This is to ensure that the state of the internal logic remains unchanged from the moment of entering the Hold condition.

If Chip Select ($\overline{\text{S}}$) goes High while the device is in the Hold condition, this has the effect of resetting the internal logic of the device. To restart communication with the device, it is necessary to drive Hold ($\overline{\text{HOLD}}$) High, and then to drive Chip Select ($\overline{\text{S}}$) Low. This prevents the device from going back to the Hold condition.

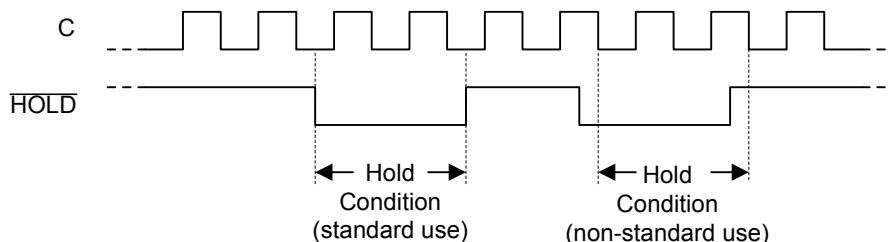
Figure 3. Hold Condition Activation

MEMORY ORGANIZATION

The memory is organized as:

- 2,097,152 bytes (8 bits each)
- 32 sectors (one (4/4/8/16/32) Kbytes & 64x31 Kbytes each)
- 8192 pages (256 bytes each).

Each page can be individually programmed (bits are programmed from 1 to 0). The device is Sector or Bulk Erasable (bits are erased from 0 to 1) but not Page Erasable.

Table 2-1. A25L16PT Memory Organization

Sector	Sector Size (Kbytes)	Address Range	
31-4	4	1FF000h	1FFFFFFh
31-4	4	1FE000h	1FEFFFFh
31-2	8	1FC000h	1FDFFFFh
31-1	16	1F8000h	1FBFFFFh
31-0	32	1F0000h	1F7FFFFh
30	64	1E0000h	1EFFFFFFh
29	64	1D0000h	1DFFFFFFh
28	64	1C0000h	1CFFFFFFh
27	64	1B0000h	1BFFFFFFh
26	64	1A0000h	1AFFFFFFh
25	64	190000h	19FFFFFFh
24	64	180000h	18FFFFFFh
23	64	170000h	17FFFFFFh
22	64	160000h	16FFFFFFh
21	64	150000h	15FFFFFFh
20	64	140000h	14FFFFFFh
19	64	130000h	13FFFFFFh
18	64	120000h	12FFFFFFh
17	64	110000h	11FFFFFFh
16	64	100000h	10FFFFFFh
15	64	F0000h	FFFFFFh
14	64	E0000h	EFFFFFFh
13	64	D0000h	DFFFFFFh
12	64	C0000h	CFFFFFFh
11	64	B0000h	BFFFFFFh
10	64	A0000h	AFFFFFFh
9	64	90000h	9FFFFFFh
8	64	80000h	8FFFFFFh
7	64	70000h	7FFFFFFh
6	64	60000h	6FFFFFFh
5	64	50000h	5FFFFFFh
4	64	40000h	4FFFFFFh
3	64	30000h	3FFFFFFh
2	64	20000h	2FFFFFFh
1	64	10000h	1FFFFFFh
0	64	00000h	0FFFFFFh

Table 2-2. A25L16PU Memory Organization

Sector	Sector Size (Kbytes)	Address Range	
31	64	1F0000h	1FFFFFFh
30	64	1E0000h	1EFFFFFFh
29	64	1D0000h	1DFFFFFFh
28	64	1C0000h	1CFFFFFFh
27	64	1B0000h	1BFFFFFFh
26	64	1A0000h	1AFFFFFFh
25	64	190000h	19FFFFFFh
24	64	180000h	18FFFFFFh
23	64	170000h	17FFFFFFh
22	64	160000h	16FFFFFFh
21	64	150000h	15FFFFFFh
20	64	140000h	14FFFFFFh
19	64	130000h	13FFFFFFh
18	64	120000h	12FFFFFFh
17	64	110000h	11FFFFFFh
16	64	100000h	10FFFFFFh
15	64	F0000h	FFFFFFh
14	64	E0000h	EFFFFFFh
13	64	D0000h	DFFFFFFh
12	64	C0000h	CFFFFFFh
11	64	B0000h	BFFFFFFh
10	64	A0000h	AFFFFFFh
9	64	90000h	9FFFFFFh
8	64	80000h	8FFFFFFh
7	64	70000h	7FFFFFFh
6	64	60000h	6FFFFFFh
5	64	50000h	5FFFFFFh
4	64	40000h	4FFFFFFh
3	64	30000h	3FFFFFFh
2	64	20000h	2FFFFFFh
1	64	10000h	1FFFFFFh
0-4	32	08000h	0FFFFFFh
0-3	16	04000h	07FFFFFFh
0-2	8	02000h	03FFFFFFh
0-1	4	01000h	01FFFFFFh
0-0	4	00000h	00FFFFFFh

INSTRUCTIONS

All instructions, addresses and data are shifted in and out of the device, most significant bit first.

Serial Data Input (DIO) is sampled on the first rising edge of Serial Clock (C) after Chip Select (\bar{S}) is driven Low. Then, the one-byte instruction code must be shifted in to the device, most significant bit first, on Serial Data Input (DIO), each bit being latched on the rising edges of Serial Clock (C).

The instruction set is listed in Table 3.

Every instruction sequence starts with a one-byte instruction code. Depending on the instruction, this might be followed by address bytes, or by data bytes, or by both or none.

In the case of a Read Data Bytes (READ), Read Data Bytes at Higher Speed (Fast_Read), Read Status Register (RDSR) or Release from Deep Power-down, Read Device Identification and Read Electronic Signature (RES) instruction, the shifted-in instruction sequence is followed by a data-out sequence. Chip Select (\bar{S}) can be driven High

after any bit of the data-out sequence is being shifted out.

In the case of a Page Program (PP), Sector Erase (SE), Bulk Erase (BE), Write Status Register (WRSR), Write Enable (WREN), Write Disable (WRDI) or Deep Power-down (DP) instruction, Chip Select (\bar{S}) must be driven High exactly at a byte boundary, otherwise the instruction is rejected, and is not executed. That is, Chip Select (\bar{S}) must be driven High when the number of clock pulses after Chip Select (\bar{S}) being driven Low is an exact multiple of eight.

All attempts to access the memory array during a Write Status Register cycle, Program cycle or Erase cycle are ignored, and the internal Write Status Register cycle, Program cycle or Erase cycle continues unaffected.

Table 3. Instruction Set

Instruction	Description	One-byte Instruction Code		Address Bytes	Dummy Bytes	Data Bytes
WREN	Write Enable	0000 0110	06h	0	0	0
WRDI	Write Disable	0000 0100	04h	0	0	0
RDSR	Read Status Register	0000 0101	05h	0	0	1 to ∞
WRSR	Write Status Register	0000 0001	01h	0	0	1
READ	Read Data Bytes	0000 0011	03h	3	0	1 to ∞
FAST_READ	Read Data Bytes at Higher Speed	0000 1011	0Bh	3	1	1 to ∞
FAST_READ_DUAL_OUTPUT	Read Data Bytes at Higher Speed by Dual Output ⁽¹⁾	00111011	3Bh	3	1	1 to ∞
FAST_READ_DUAL_INPUT-OUTPUT	Read Data Bytes at Higher Speed by Dual Input and Dual Output ⁽¹⁾	10111011	BBh	3 ⁽²⁾	1 ⁽²⁾	1 to ∞
PP	Page Program	0000 0010	02h	3	0	1 to 256
SE	Sector Erase	1101 1000	D8h	3	0	0
BE	Bulk Erase	1100 0111 or 01100000	C7h or 60h	0	0	0
DP	Deep Power-down	1011 1001	B9h	0	0	0
RDID	Read Device Identification	1001 1111	9Fh	0	0	1 to 4
RES	Release from Deep Power-down, and Read Electronic Signature	1010 1011	ABh	0	3	1 to ∞
	Release from Deep Power-down			0	0	0

Note: (1) DIO = (D₆, D₄, D₂, D₀)

DO = (D₇, D₅, D₃, D₁)

(2) Dual Input, DIO = (A₂₂, A₂₀, A₁₈,, A₆, A₄, A₂, A₀)

DO = (A₂₃, A₂₁, A₁₉,, A₇, A₅, A₃, A₁)

Write Enable (WREN)

The Write Enable (WREN) instruction (Figure 4.) sets the Write Enable Latch (WEL) bit. The Write Enable Latch (WEL) bit must be set prior to every Page Program (PP), Sector Erase (SE), Bulk Erase (BE) and Write Status Register (WRSR) instruction.

The Write Enable (WREN) instruction is entered by driving Chip Select (\bar{S}) Low, sending the instruction code, and then driving Chip Select (\bar{S}) High.

Figure 4. Write Enable (WREN) Instruction Sequence

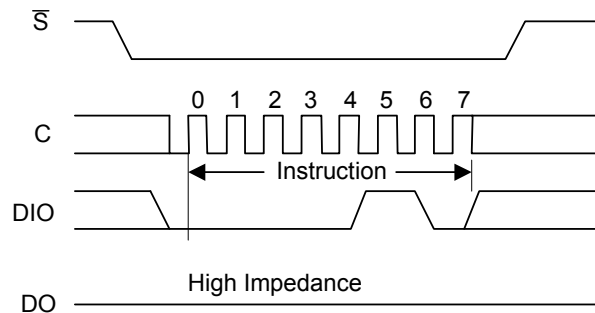

Write Disable (WRDI)

The Write Disable (WRDI) instruction (Figure 5.) resets the Write Enable Latch (WEL) bit. The Write Disable (WRDI) instruction is entered by driving Chip Select (\bar{S}) Low, sending the instruction code, and then driving Chip The Write Enable Latch (WEL) bit is reset under the following conditions:

- Power-up
- Write Disable (WRDI) instruction completion
- Write Status Register (WRSR) instruction completion
- Page Program (PP) instruction completion
- Sector Erase (SE) instruction completion
- Bulk Erase (BE) instruction completion

Figure 5. Write Disable (WRDI) Instruction Sequence

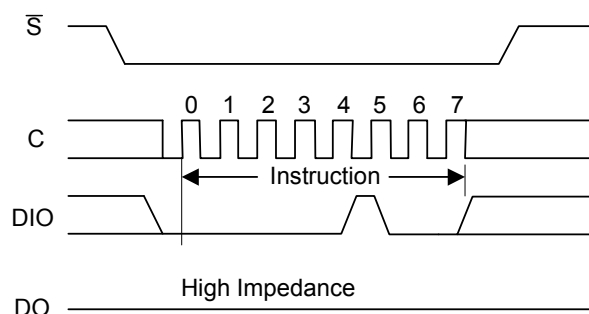

Read Status Register (RDSR)

The Read Status Register (RDSR) instruction allows the Status Register to be read. The Status Register may be read at any time, even while a Program, Erase or Write Status Register cycle is in progress. When one of these cycles is in progress, it is recommended to check the Write In Progress (WIP) bit before sending a new instruction to the device. It is also possible to read the Status Register continuously, as shown in Figure 6.

Table 4. Status Register Format

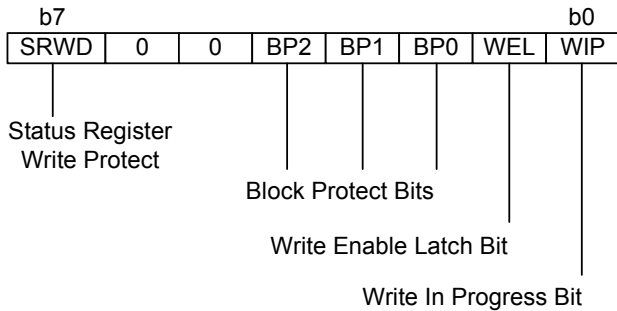

The status and control bits of the Status Register are as follows:

WIP bit. The Write In Progress (WIP) bit indicates whether the memory is busy with a Write Status Register, Program or Erase cycle. When set to 1, such a cycle is in progress, when reset to 0 no such cycle is in progress.

WEL bit. The Write Enable Latch (WEL) bit indicates the

status of the internal Write Enable Latch. When set to 1 the internal Write Enable Latch is set, when set to 0 the internal Write Enable Latch is reset and no Write Status Register, Program or Erase instruction is accepted.

BP2, BP1, BP0 bits. The Block Protect (BP2, BP1, BP0) bits are non-volatile. They define the size of the area to be software protected against Program and Erase instructions. These bits are written with the Write Status Register (WRSR) instruction. When one or both of the Block Protect (BP2, BP1, BP0) bits is set to 1, the relevant memory area (as defined in Table 1.) becomes protected against Page Program (PP) and Sector Erase (SE) instructions. The Block Protect (BP2, BP1, BP0) bits can be written provided that the Hardware Protected mode has not been set. The Bulk Erase (BE) instruction is executed if, and only if, both Block Protect (BP2, BP1, BP0) bits are 0.

SRWD bit. The Status Register Write Disable (SRWD) bit is operated in conjunction with the Write Protect (\bar{W}) signal. The Status Register Write Disable (SRWD) bit and Write Protect (\bar{W}) signal allow the device to be put in the Hardware Protected mode (when the Status Register Write Disable (SRWD) bit is set to 1, and Write Protect (\bar{W}) is driven Low). In this mode, the non-volatile bits of the Status Register (SRWD, BP2, BP1, BP0) become read-only bits and the Write Status Register (WRSR) instruction is no longer accepted for execution.

Figure 6. Read Status Register (RDSR) Instruction Sequence and Data-Out Sequence

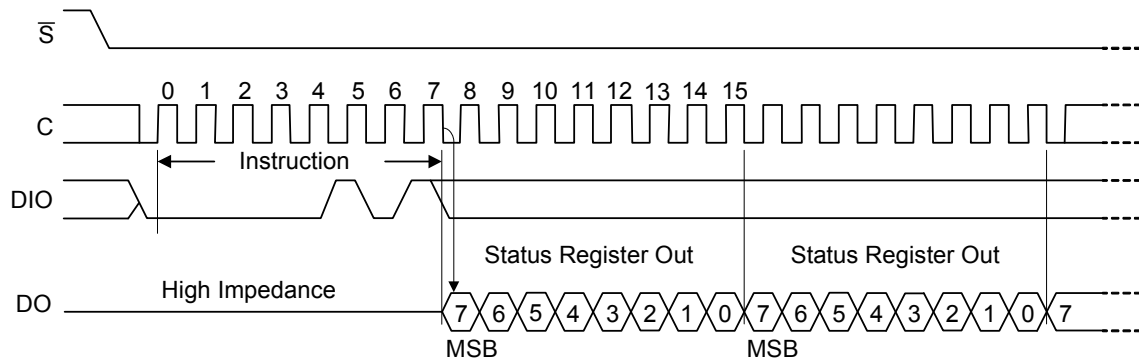

Write Status Register (WRSR)

The Write Status Register (WRSR) instruction allows new values to be written to the Status Register. Before it can be accepted, a Write Enable (WREN) instruction must previously have been executed. After the Write Enable (WREN) instruction has been decoded and executed, the device sets the Write Enable Latch (WEL).

The Write Status Register (WRSR) instruction is entered by driving Chip Select (\bar{S}) Low, followed by the instruction code and the data byte on Serial Data Input (DIO).

The instruction sequence is shown in Figure 7. The Write Status Register (WRSR) instruction has no effect on b6, b5, b1 and b0 of the Status Register. b6 and b5 are always read as 0.

Chip Select (\bar{S}) must be driven High after the eighth bit of the data byte has been latched in. If not, the Write Status Register (WRSR) instruction is not executed. As soon as Chip Select (\bar{S}) is driven High, the self-timed Write Status Register cycle (whose duration is t_w) is initiated. While the

Write Status Register cycle is in progress, the Status Register may still be read to check the value of the Write In Progress (WIP) bit. The Write In Progress (WIP) bit is 1 during the self-timed Write Status Register cycle, and is 0 when it is completed. When the cycle is completed, the Write Enable Latch (WEL) is reset.

The Write Status Register (WRSR) instruction allows the user to change the values of the Block Protect (BP2, BP1, BP0) bits, to define the size of the area that is to be treated as read-only, as defined in Table 1. The Write Status Register (WRSR) instruction also allows the user to set or reset the Status Register Write Disable (SRWD) bit in accordance with the Write Protect (\bar{W}) signal. The Status Register Write Disable (SRWD) bit and Write Protect (\bar{W}) signal allow the device to be put in the Hardware Protected Mode (HPM). The Write Status Register (WRSR) instruction is not executed once the Hardware Protected Mode (HPM) is entered.

Figure 7. Write Status Register (WRSR) Instruction Sequence

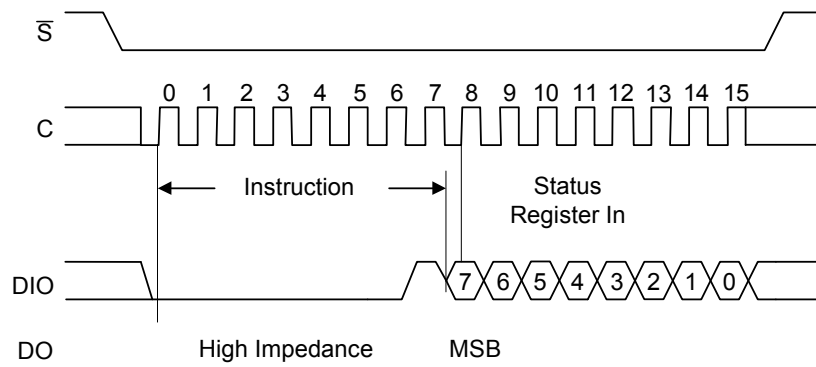

Table 5. Protection Modes

\overline{W} Signal	SRWD Bit	Mode	Write Protection of the Status Register	Memory Content	
				Protected Area ¹	Unprotected Area ¹
1	0	Software Protected (SPM)	Status Register is Writable (if the WREN instruction has set the WEL bit) The values in the SRWD, BP2, BP1 and BP0 bits can be changed	Protected against Page Program, Sector Erase and Bulk Erase	Ready to accept Page Program and Sector Erase instructions
0	0				
1	1				
0	1	Hardware Protected (HPM)	Status Register is Hardware write protected The values in the SRWD, BP2, BP1 and BP0 bits cannot be changed	Protected against Page Program, Sector Erase and Bulk Erase	Ready to accept Page Program and Sector Erase instructions

Note: 1. As defined by the values in the Block Protect (BP2, BP1, BP0) bits of the Status Register, as shown in Table 1.

The protection features of the device are summarized in Table 5.

When the Status Register Write Disable (SRWD) bit of the Status Register is 0 (its initial delivery state), it is possible to write to the Status Register provided that the Write Enable Latch (WEL) bit has previously been set by a Write Enable (WREN) instruction, regardless of the whether Write Protect (\overline{W}) is driven High or Low.

When the Status Register Write Disable (SRWD) bit of the Status Register is set to 1, two cases need to be considered, depending on the state of Write Protect (\overline{W}):

- If Write Protect (\overline{W}) is driven High, it is possible to write to the Status Register provided that the Write Enable Latch (WEL) bit has previously been set by a Write Enable (WREN) instruction.
- If Write Protect (\overline{W}) is driven Low, it is *not* possible to write to the Status Register *even* if the Write Enable Latch (WEL) bit has previously been set by a Write Enable (WREN) instruction. (Attempts to write to the

Status Register are rejected, and are not accepted for execution). As a consequence, all the data bytes in the memory area that are software protected (SPM) by the Block Protect (BP2, BP1, BP0) bits of the Status Register, are also hardware protected against data modification.

Regardless of the order of the two events, the Hardware Protected Mode (HPM) can be entered:

- by setting the Status Register Write Disable (SRWD) bit after driving Write Protect (\overline{W}) Low
- or by driving Write Protect (\overline{W}) Low after setting the Status Register Write Disable (SRWD) bit.

The only way to exit the Hardware Protected Mode (HPM) once entered is to pull Write Protect (\overline{W}) High.

If Write Protect (\overline{W}) is permanently tied High, the Hardware Protected Mode (HPM) can never be activated, and only the Software Protected Mode (SPM), using the Block Protect (BP2, BP1, BP0) bits of the Status Register, can be used.

Read Data Bytes (READ)

The device is first selected by driving Chip Select (\bar{S}) Low. The instruction code for the Read Data Bytes (READ) instruction is followed by a 3-byte address (A23-A0), each bit being latched-in during the rising edge of Serial Clock (C). Then the memory contents, at that address, is shifted out on Serial Data Output (DO), each bit being shifted out, at a maximum frequency f_R , during the falling edge of Serial Clock (C).

The instruction sequence is shown in Figure 8. The first byte addressed can be at any location. The address is automatically incremented to the next higher address after each byte of data is shifted out. The whole memory can,

therefore, be read with a single Read Data Bytes (READ) instruction. When the highest address is reached, the address counter rolls over to 000000h, allowing the read sequence to be continued indefinitely.

The Read Data Bytes (READ) instruction is terminated by driving Chip Select (\bar{S}) High. Chip Select (\bar{S}) can be driven High at any time during data output. Any Read Data Bytes (READ) instruction, while an Erase, Program or Write cycle is in progress, is rejected without having any effects on the cycle that is in progress.

Figure 8. Read Data Bytes (READ) Instruction Sequence and Data-Out Sequence

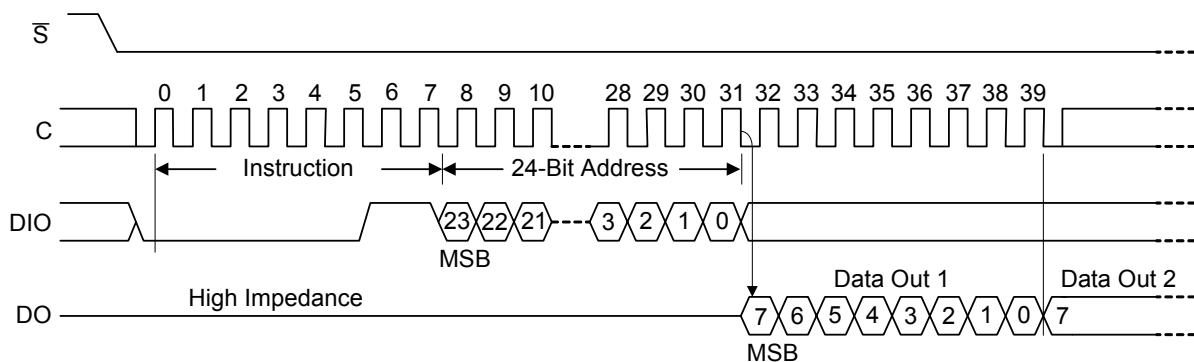

Read Data Bytes at Higher Speed (FAST_READ)

The device is first selected by driving Chip Select (\bar{S}) Low. The instruction code for the Read Data Bytes at Higher Speed (FAST_READ) instruction is followed by a 3-byte address (A23-A0) and a dummy byte, each bit being latched-in during the rising edge of Serial Clock (C). Then the memory contents, at that address, is shifted out on Serial Data Output (DO), each bit being shifted out, at a maximum frequency f_C , during the falling edge of Serial Clock (C).

The instruction sequence is shown in Figure 9. The first byte addressed can be at any location. The address is automatically incremented to the next higher address after each byte of data is shifted out. The whole memory can, therefore, be read with a single Read Data Bytes at Higher

Speed (FAST_READ) instruction. When the highest address is reached, the address counter rolls over to 000000h, allowing the read sequence to be continued indefinitely.

The Read Data Bytes at Higher Speed (FAST_READ) instruction is terminated by driving Chip Select (\bar{S}) High.

Chip Select (\bar{S}) can be driven High at any time during data output. Any Read Data Bytes at Higher Speed (FAST_READ) instruction, while an Erase, Program or Write cycle is in progress, is rejected without having any effects on the cycle that is in progress.

Figure 9. Read Data Bytes at Higher Speed (FAST_READ) Instruction Sequence and Data-Out Sequence

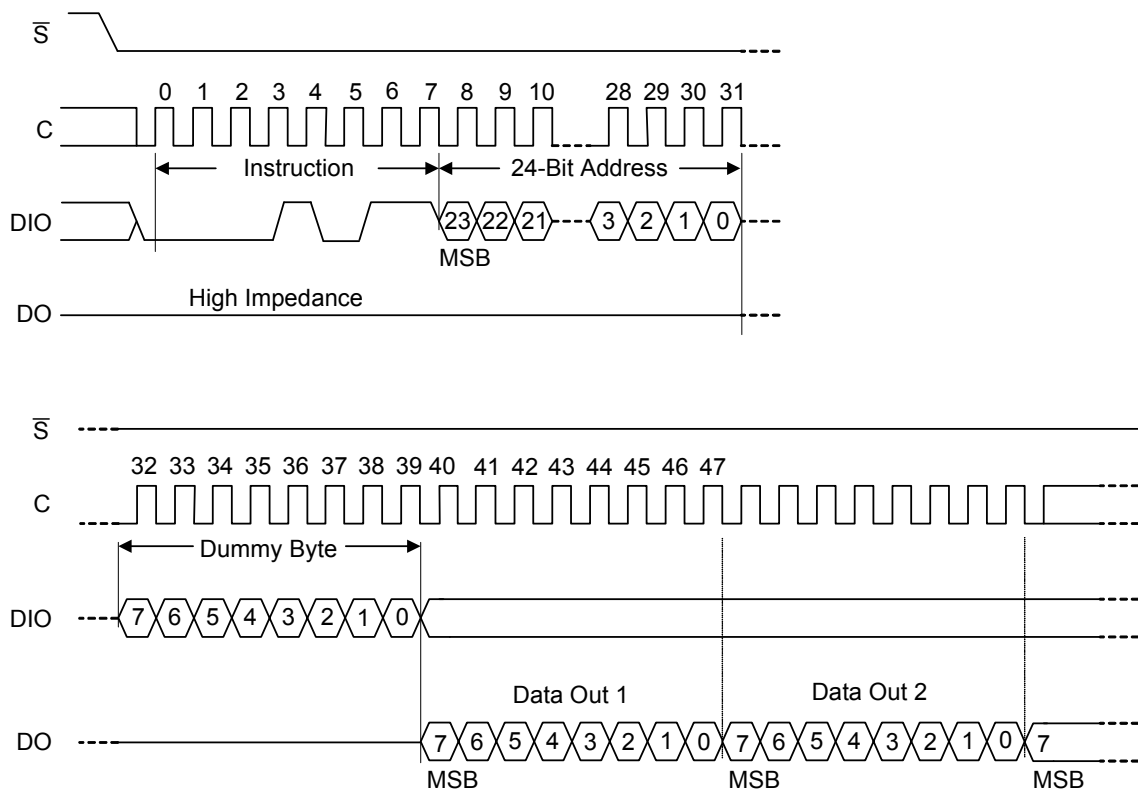

Note: Address bits A23 to A21 are Don't Care.

Fast Read Dual Output (3Bh)

The Fast Read Dual Output (3Bh) instruction is similar to the Fast_Read (0Bh) instruction except the data is output on two pins, DO and DIO, instead of just DO. This allows data to be transferred from the A25L16P at twice the rate of standard SPI devices.

Similar to the Fast Read instruction, the Fast Read Dual Output instruction can operate at the highest possible frequency of f_c (See AC Characteristics). This is

accomplished by adding eight “dummy” clocks after the 24-bit address as shown in figure 10. The dummy clocks allow the device’s internal circuits additional time for setting up the initial address. The input data during the dummy clocks is “don’t care”. However, the DIO pin should be high-impedance prior to the falling edge of the first data out clock.

Figure 10. FAST_READ_DUAL_OUTPUT Instruction Sequence and Data-Out Sequence

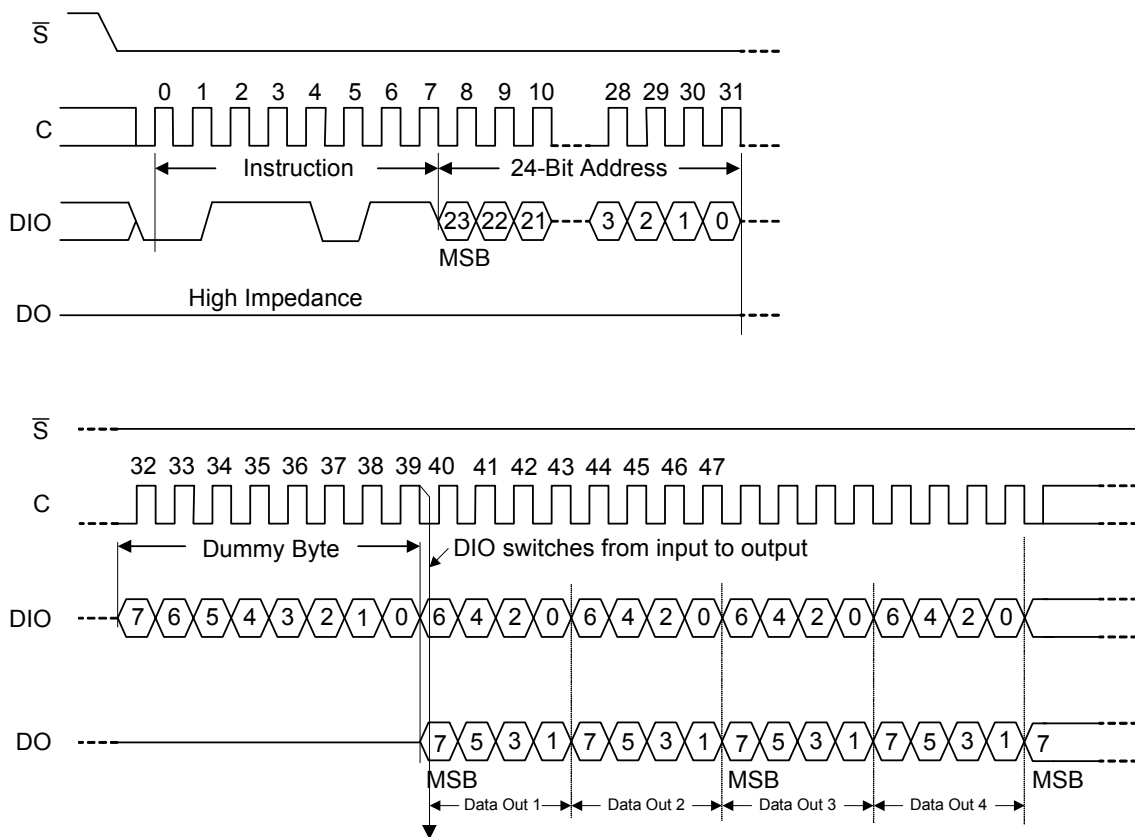

Note: Address bits A23 to A21 are Don't Care.

Fast Read Dual Input-Output (BBh)

The Fast Read Dual Input-Output (BBh) instruction is similar to the Fast_Read (0Bh) instruction except the data is input and output on two pins, DO and DIO, instead of just DO. This allows data to be transferred from the A25L16P at twice the rate of standard SPI devices.

Similar to the Fast Read instruction, the Fast Read Dual Output instruction can operate at the highest possible frequency of f_c (See AC Characteristics). This is

accomplished by adding four “dummy” clocks after the 24-bit address as shown in figure 11. The dummy clocks allow the device’s internal circuits additional time for setting up the initial address. The input data during the dummy clocks is “don’t care”. However, the DIO and DO pins should be high-impedance prior to the falling edge of the first data out clock.

Figure 11. FAST_READ_DUAL_INPUT-OUTPUT Instruction Sequence and Data-Out Sequence

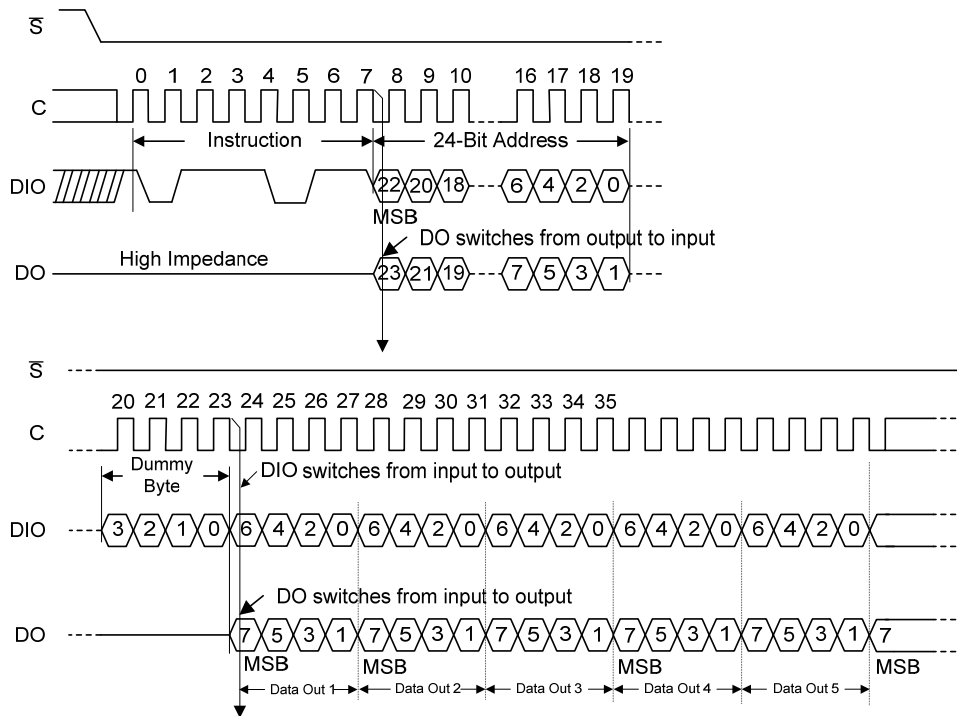

Note: Address bits A23 to A21 are Don't Care.

Page Program (PP)

The Page Program (PP) instruction allows bytes to be programmed in the memory (changing bits from 1 to 0). Before it can be accepted, a Write Enable (WREN) instruction must previously have been executed. After the Write Enable (WREN) instruction has been decoded, the device sets the Write Enable Latch (WEL).

The Page Program (PP) instruction is entered by driving Chip Select (\bar{S}) Low, followed by the instruction code, three address bytes and at least one data byte on Serial Data Input (DIO). If the 8 least significant address bits (A7-A0) are not all zero, all transmitted data that goes beyond the end of the current page are programmed from the start address of the same page (from the address whose 8 least significant bits (A7-A0) are all zero). Chip Select (\bar{S}) must be driven Low for the entire duration of the sequence.

The instruction sequence is shown in Figure 12. If more than 256 bytes are sent to the device, previously latched data are discarded and the last 256 data bytes are guaranteed to be

programmed correctly within the same page. If less than 256 Data bytes are sent to device, they are correctly programmed at the requested addresses without having any effects on the other bytes of the same page.

Chip Select (\bar{S}) must be driven High after the eighth bit of the last data byte has been latched in, otherwise the Page Program (PP) instruction is not executed.

As soon as Chip Select (\bar{S}) is driven High, the self-timed Page Program cycle (whose duration is t_{pp}) is initiated. While the Page Program cycle is in progress, the Status Register may be read to check the value of the Write In Progress (WIP) bit. The Write In Progress (WIP) bit is 1 during the self-timed Page Program cycle, and is 0 when it is completed. At some unspecified time before the cycle is completed, the Write Enable Latch (WEL) bit is reset.

A Page Program (PP) instruction applied to a page which is protected by the Block Protect (BP2, BP1, BP0) bits (see Table 2 and Table 1) is not executed.

Figure 12. Page Program (PP) Instruction Sequence

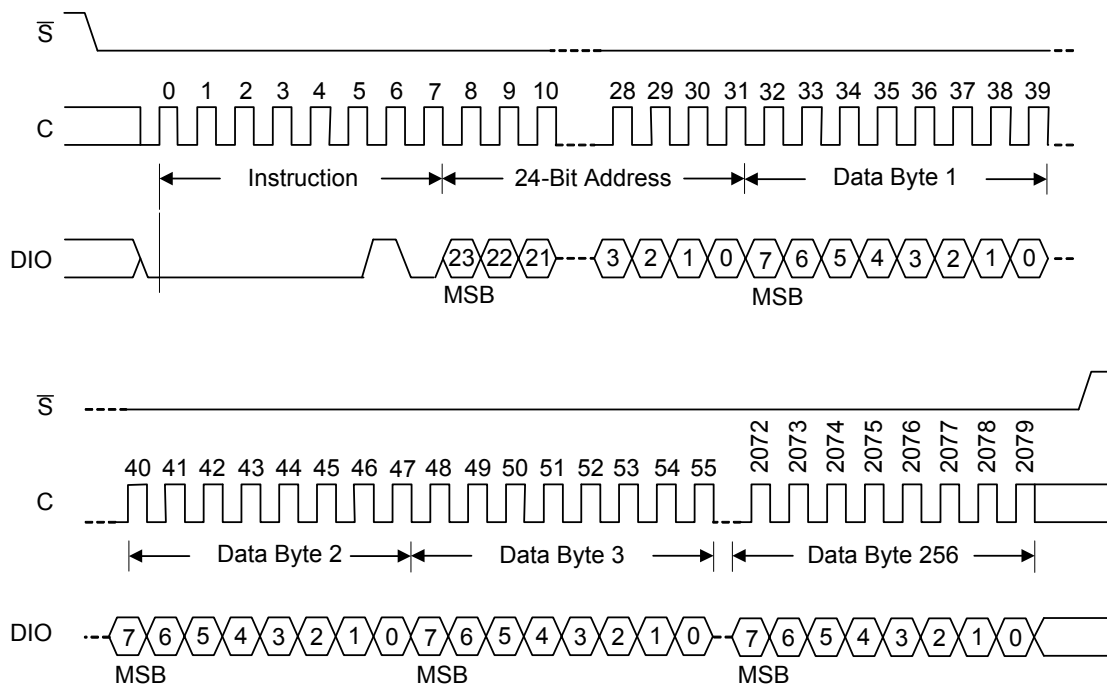

Note: Address bits A23 to A21 are Don't Care.

Sector Erase (SE)

The Sector Erase (SE) instruction sets all bits to 1 (FFh). Before it can be accepted, a Write Enable (WREN) instruction must previously have been executed. After the Write Enable (WREN) instruction has been decoded, the device sets the Write Enable Latch (WEL).

The Sector Erase (SE) instruction is entered by driving Chip Select (\bar{S}) Low, followed by the instruction code on Serial Data Input (DIO). Chip Select (\bar{S}) must be driven Low for the entire duration of the sequence.

The instruction sequence is shown in Figure 13. Chip Select (\bar{S}) must be driven High after the eighth bit of the instruction code has been latched in, otherwise the Sector Erase

instruction is not executed. As soon as Chip Select (\bar{S}) is driven High, the self-timed Sector Erase cycle (whose duration is t_{BE}) is initiated. While the Sector Erase cycle is in progress, the Status Register may be read to check the value of the Write In Progress (WIP) bit. The Write In Progress (WIP) bit is 1 during the self-timed Sector Erase cycle, and is 0 when it is completed. At some unspecified time before the cycle is completed, the Write Enable Latch (WEL) bit is reset. The Sector Erase (SE) instruction is executed only if all Block Protect (BP2, BP1, BP0) bits are 0. The Sector Erase (SE) instruction is ignored if one, or more, sectors are protected.

Figure 13. Sector Erase (SE) Instruction Sequence

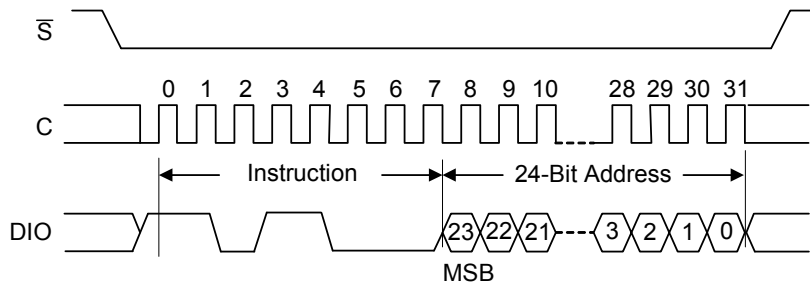

Notes: Address bits A23 to A21 are Don't Care.

Bulk Erase (BE)

The Bulk Erase (BE) instruction sets all bits to 1 (FFh). Before it can be accepted, a Write Enable (WREN) instruction must previously have been executed. After the Write Enable (WREN) instruction has been decoded, the device sets the Write Enable Latch (WEL).

The Bulk Erase (BE) instruction is entered by driving Chip Select (\bar{S}) Low, followed by the instruction code on Serial Data Input (DIO). Chip Select (\bar{S}) must be driven Low for the entire duration of the sequence.

The instruction sequence is shown in Figure 14. Chip Select (\bar{S}) must be driven High after the eighth bit of the instruction code has been latched in, otherwise the Bulk Erase

instruction is not executed. As soon as Chip Select (\bar{S}) is driven High, the self-timed Bulk Erase cycle (whose duration is t_{BE}) is initiated. While the Bulk Erase cycle is in progress, the Status Register may be read to check the value of the Write In Progress (WIP) bit. The Write In Progress (WIP) bit is 1 during the self-timed Bulk Erase cycle, and is 0 when it is completed. At some unspecified time before the cycle is completed, the Write Enable Latch (WEL) bit is reset.

The Bulk Erase (BE) instruction is executed only if all Block Protect (BP2, BP1, BP0) bits are 0. The Bulk Erase (BE) instruction is ignored if one, or more, sectors are protected.

Figure 14. Bulk Erase (BE) Instruction Sequence

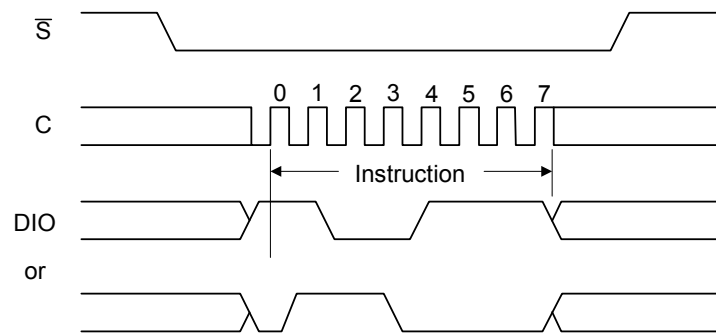

Notes: Address bits A23 to A21 are Don't Care.

Deep Power-down (DP)

Executing the Deep Power-down (DP) instruction is the only way to put the device in the lowest consumption mode (the Deep Power-down mode). It can also be used as an extra software protection mechanism, while the device is not in active use, since in this mode, the device ignores all Write, Program and Erase instructions.

Driving Chip Select (\overline{S}) High deselects the device, and puts the device in the Standby mode (if there is no internal cycle currently in progress). But this mode is not the Deep Power-down mode. The Deep Power-down mode can only be entered by executing the Deep Power-down (DP) instruction, to reduce the standby current (from I_{CC1} to I_{CC2} , as specified in DC Characteristics Table.).

Once the device has entered the Deep Power-down mode, all instructions are ignored except the Release from Deep Power-down and Read Electronic Signature (RES) instruction. This releases the device from this mode. The Release from Deep Power-down and Read Electronic Signature (RES) instruction also allows the Electronic Signature of the device to be output on Serial Data Output (DO).

The Deep Power-down mode automatically stops at Power-down, and the device always Powers-up in the Standby mode.

The Deep Power-down (DP) instruction is entered by driving Chip Select (\overline{S}) Low, followed by the instruction code on Serial Data Input (DIO). Chip Select (\overline{S}) must be driven Low for the entire duration of the sequence. The instruction sequence is shown in Figure 15.

Chip Select (\overline{S}) must be driven High after the eighth bit of the instruction code has been latched in, otherwise the Deep Power-down (DP) instruction is not executed. As soon as

Chip Select (\overline{S}) is driven High, it requires a delay of t_{DP} before the supply current is reduced to I_{CC2} and the Deep Power-down mode is entered.

Any Deep Power-down (DP) instruction, while an Erase, Program or Write cycle is in progress, is rejected without having any effects on the cycle that is in progress.

Figure 15. Deep Power-down (DP) Instruction Sequence

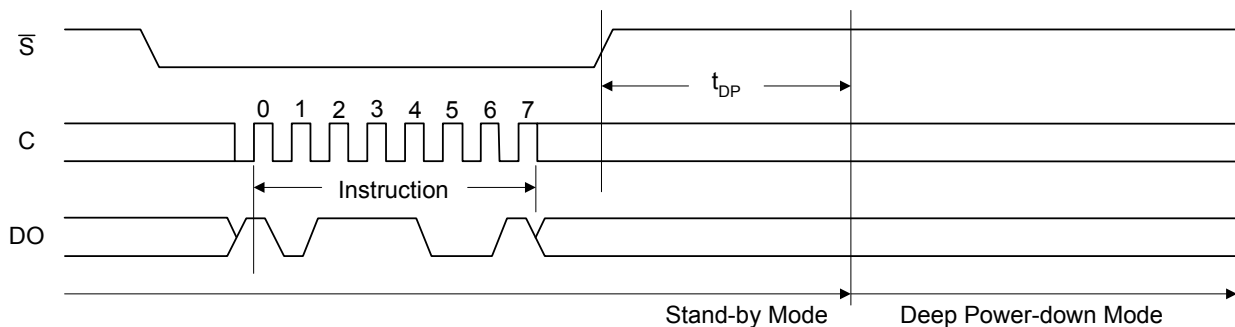

Read Device Identification (RDID)

The Read Identification (RDID) instruction allows the 8-bit manufacturer identification code to be read, followed by two bytes of device identification. The manufacturer identification is assigned by JEDEC, and has the value 37h, plus the continuation identification for AMIC Technology. The device identification is assigned by the device manufacturer, and indicates the memory in the first bytes (20h), and the memory capacity of the device in the second byte (15h, bottom) or (25h, top).

Any Read Identification (RDID) instruction while an Erase, or Program cycle is in progress, is not decoded, and has no effect on the cycle that is in progress.

The device is first selected by driving Chip Select (\bar{S}) Low.

Then, the 8-bit instruction code for the instruction is shifted in. This is followed by the 32-bit device identification, stored in the memory, being shifted out on Serial Data Output (DO), each bit being shifted out during the falling edge of Serial Clock (C).

The instruction sequence is shown in Figure 16. The Read Identification (RDID) instruction is terminated by driving Chip Select (\bar{S}) High at any time during data output.

When Chip Select (\bar{S}) is driven High, the device is put in the Stand-by Power mode. Once in the Stand-by Power mode, the device waits to be selected, so that it can receive, decode and execute instructions.

Table. Read Identification (READ_ID) Data-Out Sequence

Manufacture Identification		Device Identification	
Continuation ID	Manufacture ID	Memory Type	Memory Capacity
7Fh	37h	20h	15h (Bottom)
			25h (Top)

Figure 16. Read Identification (RDID) Data-Out Sequence

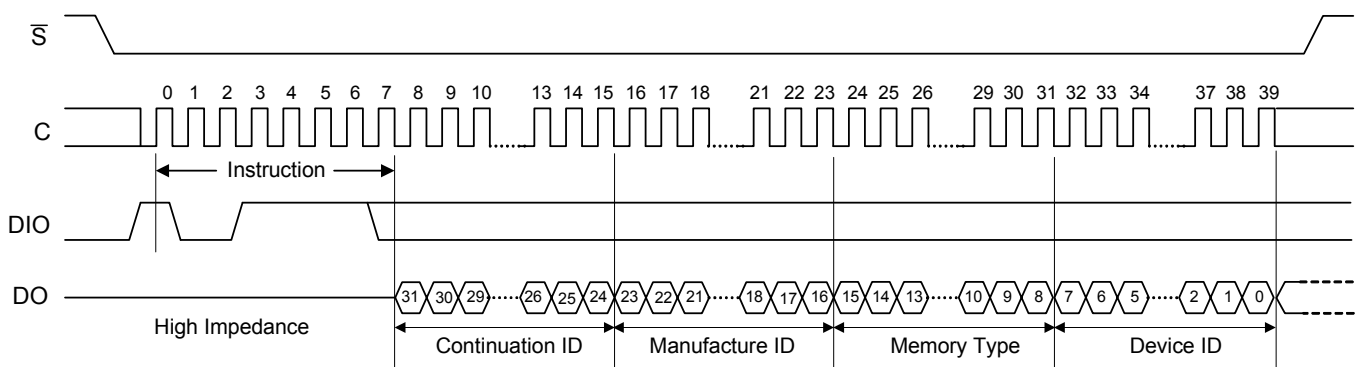

Release from Deep Power-down and Read Electronic Signature (RES)

Once the device has entered the Deep Power-down mode, all instructions are ignored except the Release from Deep Power-down and Read Electronic Signature (RES) instruction. Executing this instruction takes the device out of the Deep Power-down mode.

The instruction can also be used to read, on Serial Data Output (DO), the 8-bit Electronic Signature, whose value for the A25L16P is 14h.

Except while an Erase, Program or Write Status Register cycle is in progress, the Release from Deep Power-down and Read Electronic Signature (RES) instruction always provides access to the 8-bit Electronic Signature of the device, and can be applied even if the Deep Power-down mode has not been entered.

Any Release from Deep Power-down and Read Electronic Signature (RES) instruction while an Erase, Program or Write Status Register cycle is in progress, is not decoded, and has no effect on the cycle that is in progress.

The device is first selected by driving Chip Select (\bar{S}) Low. The instruction code is followed by 3 dummy bytes, each bit being latched-in on Serial Data Input (DIO) during the rising

edge of Serial Clock (C). Then, the 8-bit Electronic Signature, stored in the memory, is shifted out on Serial Data Output (DO), each bit being shifted out during the falling edge of Serial Clock (C).

The instruction sequence is shown in Figure 17.

The Release from Deep Power-down and Read Electronic Signature (RES) instruction is terminated by driving Chip Select (\bar{S}) High after the Electronic Signature has been read at least once. Sending additional clock cycles on Serial Clock (C), while Chip Select (\bar{S}) is driven Low, cause the Electronic Signature to be output repeatedly.

When Chip Select (\bar{S}) is driven High, the device is put in the Stand-by Power mode. If the device was not previously in the Deep Power-down mode, the transition to the Stand-by Power mode is immediate. If the device was previously in the Deep Power-down mode, though, the transition to the Stand-by Power mode is delayed by t_{RES2} , and Chip Select (\bar{S}) must remain High for at least $t_{RES2(max)}$, as specified in AC Characteristics Table . Once in the Stand-by Power mode, the device waits to be selected, so that it can receive, decode and execute instructions.

Figure 17. Release from Deep Power-down and Read Electronic Signature (RES) Instruction Sequence and Data-Out Sequence

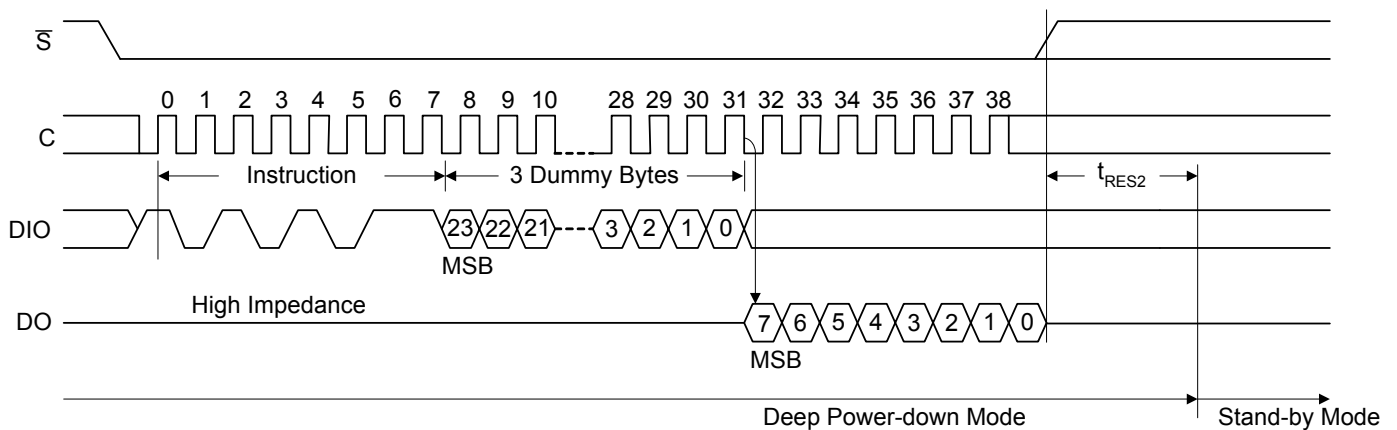

Note: The value of the 8-bit Electronic Signature, for the A25L16P, is 14h.

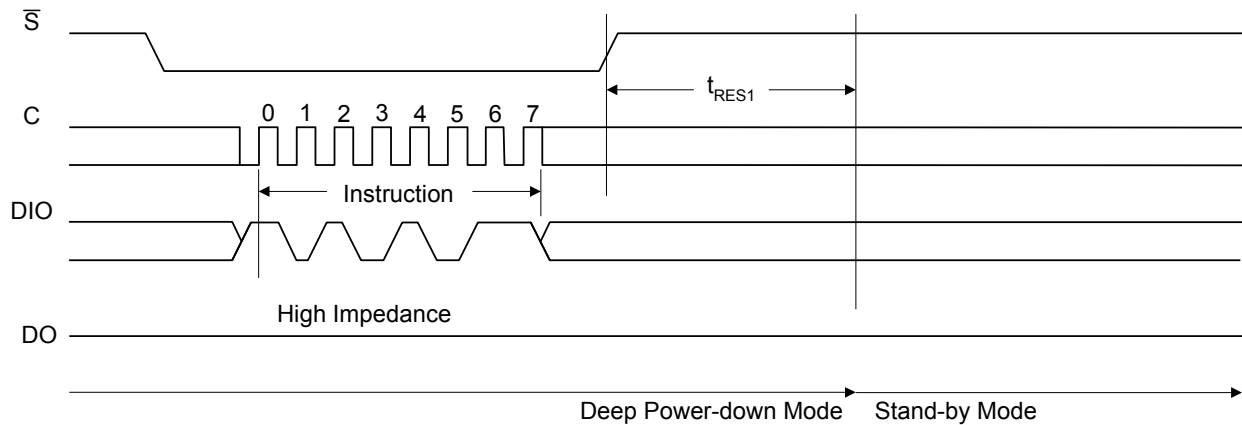
Figure 18. Release from Deep Power-down (RES) Instruction Sequence

Driving Chip Select (\overline{S}) High after the 8-bit instruction byte has been received by the device, but before the whole of the 8-bit Electronic Signature has been transmitted for the first time (as shown in Figure 18.), still insures that the device is put into Stand-by Power mode. If the device was not previously in the Deep Power-down mode, the transition to the Stand-by Power mode is immediate. If the device was

previously in the Deep Power-down mode, though, the transition to the Stand-by Power mode is delayed by t_{RES1} , and Chip Select (\overline{S}) must remain High for at least $t_{RES1}(\max)$, as specified in AC Characteristics Table. Once in the Stand-by Power mode, the device waits to be selected, so that it can receive, decode and execute instructions.

POWER-UP AND POWER-DOWN

At Power-up and Power-down, the device must not be selected (that is Chip Select (\bar{S}) must follow the voltage applied on V_{CC}) until V_{CC} reaches the correct value:

- $V_{CC}(\text{min})$ at Power-up, and then for a further delay of t_{VSL}
- V_{SS} at Power-down

Usually a simple pull-up resistor on Chip Select (\bar{S}) can be used to insure safe and proper Power-up and Power-down. To avoid data corruption and inadvertent write operations during power up, a Power On Reset (POR) circuit is included. The logic inside the device is held reset while V_{CC} is less than the POR threshold value, V_{WI} – all operations are disabled, and the device does not respond to any instruction. Moreover, the device ignores all Write Enable (WREN), Page Program (PP), Sector Erase (SE), Bulk Erase (BE) and Write Status Register (WRSR) instructions until a time delay of t_{PUW} has elapsed after the moment that V_{CC} rises above the V_{WI} threshold. However, the correct operation of the device is not guaranteed if, by this time, V_{CC} is still below $V_{CC}(\text{min})$. No Write Status Register, Program or Erase instructions should be sent until the later of:

- t_{PUW} after V_{CC} passed the V_{WI} threshold
- t_{VSL} after V_{CC} passed the $V_{CC}(\text{min})$ level

These values are specified in Table 6.

If the delay, t_{VSL} , has elapsed, after V_{CC} has risen above $V_{CC}(\text{min})$, the device can be selected for READ instructions even if the t_{PUW} delay is not yet fully elapsed.

At Power-up, the device is in the following state:

- The device is in the Standby mode (not the Deep Power-down mode).
- The Write Enable Latch (WEL) bit is reset.

Normal precautions must be taken for supply rail decoupling, to stabilize the V_{CC} feed. Each device in a system should have the V_{CC} rail decoupled by a suitable capacitor close to the package pins. (Generally, this capacitor is of the order of $0.1\mu\text{F}$).

At Power-down, when V_{CC} drops from the operating voltage, to below the POR threshold value, V_{WI} , all operations are disabled and the device does not respond to any instruction. (The designer needs to be aware that if a Power-down occurs while a Write, Program or Erase cycle is in progress, some data corruption can result.)

Figure 19. Power-up Timing

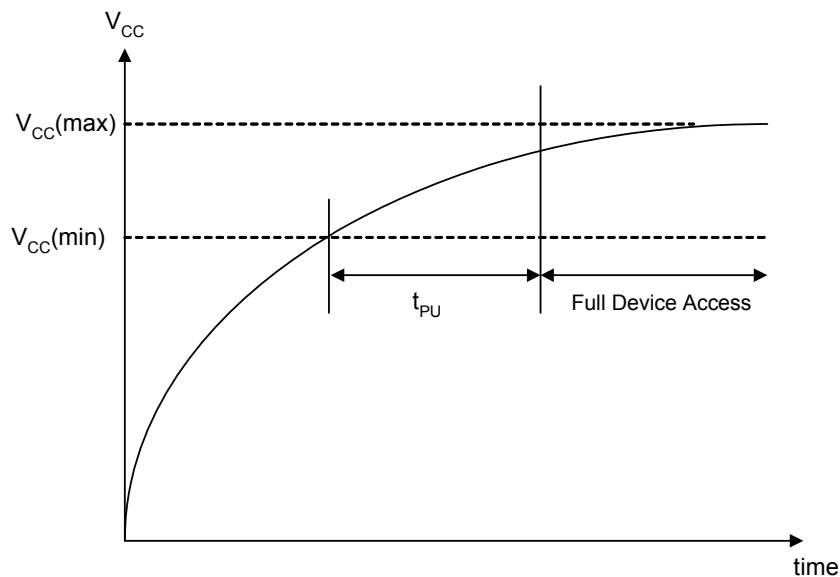

Table 6. Power-Up Timing

Symbol	Parameter	Min.	Max.	Unit
V _{CC(min)}	V _{CC} (minimum)	2.7		V
t _{PU}	V _{CC} (min) to device operation	10		ms

Note: These parameters are characterized only.

INITIAL DELIVERY STATE

The device is delivered with the memory array erased: all bits are set to 1 (each byte contains FFh). The Status Register contains 00h (all Status Register bits are 0).

Absolute Maximum Ratings*

Storage Temperature (TSTG)	-65°C to + 150°C
Lead Temperature during Soldering (Note 1)	
D.C. Voltage on Any Pin to Ground Potential	-0.6V to VCC+0.6V
Transient Voltage (<20ns) on Any Pin to Ground Potential	-2.0V to VCC+2.0V
Supply Voltage (VCC)	-0.6V to +4.0V
Electrostatic Discharge Voltage (Human Body model) (VESD) (Note 2)	-2000V to 2000V

***Comments**

Stressing the device above the rating listed in the Absolute Maximum Ratings" table may cause permanent damage to the device. These are stress ratings only and operation of the device at these or any other conditions above those indicated in the Operating sections of this specification is not implied. Exposure to Absolute Maximum Rating conditions for extended periods may affect device reliability. Refer also to the AMIC SURE Program and other relevant quality documents.

Notes:

1. Compliant with JEDEC Std J-STD-020B (for small body, Sn-Pb or Pb assembly).
2. JEDEC Std JESD22-A114A (C1=100 pF, R1=1500 Ω , R2=500Ω)

DC AND AC PARAMETERS

This section summarizes the operating and measurement conditions, and the DC and AC characteristics of the device. The parameters in the DC and AC Characteristic tables that follow are derived from tests performed under the

Measurement Conditions summarized in the relevant tables. Designers should check that the operating conditions in their circuit match the measurement conditions when relying on the quoted parameters.

Table 7. Operating Conditions

Symbol	Parameter	Min.	Max.	Unit
V _{CC}	Supply Voltage	2.7	3.6	V
T _A	Ambient Operating Temperature	-40	85	°C

Table 8. Data Retention and Endurance

Parameter	Condition	Min.	Max.	Unit
Erase/Program Cycles	At 85°C		100,000	Cycles per sector
Data Retention	At 85°C		20	Years

Note: 1. This is preliminary data

Table 9. Capacitance

Symbol	Parameter	Test Condition	Min.	Max.	Unit
C _{OUT}	Output Capacitance (DO)	V _{OUT} = 0V		8	pF
C _{IN}	Input Capacitance (other pins)	V _{IN} = 0V		6	pF

Note: Sampled only, not 100% tested, at T_A=25°C and a frequency of 33 MHz.

Table 10. DC Characteristics

Symbol	Parameter	Test Condition	Min.	Max.	Unit
I_{LI}	Input Leakage Current			± 2	μA
I_{LO}	Output Leakage Current			± 2	μA
I_{CC1}	Standby Current	$\bar{S} = V_{CC}, V_{IN} = V_{SS} \text{ or } V_{CC}$		10	μA
I_{CC2}	Deep Power-down Current	$\bar{S} = V_{CC}, V_{IN} = V_{SS} \text{ or } V_{CC}$		10	μA
I_{CC3}	Operating Current (READ)	$C = 0.1V_{CC} / 0.9.V_{CC}$ at 50MHz, DO = open		16	mA
		$C = 0.1V_{CC} / 0.9.V_{CC}$ at 33MHz, DO = open		12	mA
I_{CC4}	Operating Current (PP)	$\bar{S} = V_{CC}$		15	mA
I_{CC5}	Operating Current (WRSR)	$\bar{S} = V_{CC}$		15	mA
I_{CC6}	Operating Current (SE)	$\bar{S} = V_{CC}$		15	mA
I_{CC7}	Operating Current (BE)	$\bar{S} = V_{CC}$		15	mA
V_{IL}	Input Low Voltage		-0.5	$0.3V_{CC}$	V
V_{IH}	Input High Voltage		$0.7V_{CC}$	$V_{CC}+0.4$	V
V_{OL}	Output Low Voltage	$I_{OL} = 1.6mA$		0.4	V
V_{OH}	Output High Voltage	$I_{OH} = -100\mu A$	$V_{CC}-0.2$		V

Note: 1. This is preliminary data at 85°C

Table 11. Instruction Times

Symbol	Alt.	Parameter	Min.	Typ.	Max.	Unit
t_W		Write Status Register Cycle Time		100	300	ms
t_{PP}		Page Program Cycle Time		3	5	ms
t_{SE}		Sector Erase Cycle Time		1	3	s
t_{BE}		Bulk Erase Cycle Time		20	40	s

Note: 1. At 85°C

2. This is preliminary data

Table 12. AC Measurement Conditions

Symbol	Parameter	Min.	Max.	Unit
C_L	Load Capacitance	30		pF
	Input Rise and Fall Times		5	ns
	Input Pulse Voltages	$0.2V_{CC}$ to $0.8V_{CC}$		V
	Input Timing Reference Voltages	$0.3V_{CC}$ to $0.7V_{CC}$		V
	Output Timing Reference Voltages	$V_{CC} / 2$		V

Note: Output Hi-Z is defined as the point where data out is no longer driven.

Figure 20. AC Measurement I/O Waveform

Table 13. AC Characteristics

Symbol	Alt.	Parameter	Min. ⁵	Typ.	Max. ⁵	Unit
f_C	f_C	Clock Frequency for the following instructions: FAST_READ, PP, SE, BE, DP, RES, RDID, WREN, WRDI, RDSR, WRSR	D.C.		85	MHz
f_R		Clock Frequency for READ instructions	D.C.		50	MHz
t_{CH}^1	t_{CLH}	Clock High Time	6			ns
t_{CL}^1	t_{CLL}	Clock Low Time	5			ns
t_{CLCH}^2		Clock Rise Time ³ (peak to peak)	0.1			V/ns
t_{CHCL}^2		Clock Fall Time ³ (peak to peak)	0.1			V/ns
t_{SLCH}	t_{CSS}	\bar{S} Active Setup Time (relative to C)	5			ns
t_{CHSL}		\bar{S} Not Active Hold Time (relative to C)	5			ns
t_{DVCH}	t_{DSU}	Data In Setup Time	5			ns
t_{CHDX}	t_{DH}	Data In Hold Time	5			ns
t_{CHSH}		\bar{S} Active Hold Time (relative to C)	5			ns
t_{SHCH}		\bar{S} Not Active Setup Time (relative to C)	5			ns
t_{SHSL}	t_{CSH}	\bar{S} Deselect Time	100			ns
t_{SHQZ}^2	t_{DIS}	Output Disable Time			8	ns
t_{CLQV}	t_V	Clock Low to Output Valid			8	ns
t_{CLQX}	t_{HO}	Output Hold Time	0			ns
t_{HLCH}		\overline{HOLD} Setup Time (relative to C)	5			ns
t_{CHHH}		\overline{HOLD} Hold Time (relative to C)	5			ns
t_{HHCH}		\overline{HOLD} Setup Time (relative to C)	5			ns
t_{CHHL}		\overline{HOLD} Hold Time (relative to C)	5			ns
t_{HHQX}^2	t_{LZ}	\overline{HOLD} to Output Low-Z			8	ns
t_{HLQX}^2	t_{HZ}	\overline{HOLD} to Output High-Z			8	ns
t_{WHSL}^4		Write Protect Setup Time	20			ns
t_{SHWL}^4		Write Protect Hold Time	100			ns
t_{DP}^2		\bar{S} High to Deep Power-down Mode			3	μ s
t_{RES1}^2		\bar{S} High to Standby Mode without Electronic Signature Read			30	μ s
t_{RES2}^2		\bar{S} High to Standby Mode with Electronic Signature Read			30	μ s
t_W		Write Status Register Cycle Time		100	300	ms
t_{PP}		Page Program Cycle Time		1.5	5	ms
t_{SE}		Sector Erase Cycle Time		1	3	s
t_{BE}		Bulk Erase Cycle Time		20	40	s

- Note: 1. $t_{CH} + t_{CL}$ must be greater than or equal to $1/f_C$
 2. Value guaranteed by characterization, not 100% tested in production.
 3. Expressed as a slew-rate.
 4. Only applicable as a constraint for a WRSR instruction when SRWD is set at 1.

Figure 21. Serial Input Timing

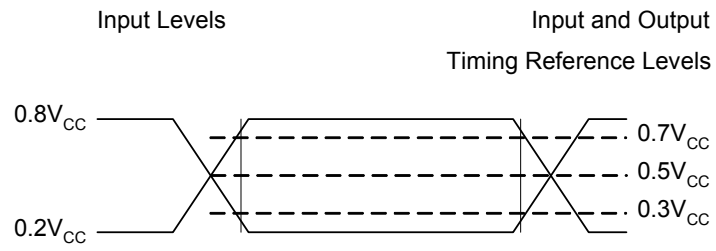
Figure 22. Write Protect Setup and Hold Timing during WRSR when SRWD=1

Figure 23. Hold Timing

Figure 24. Output Timing

* DIO is output pin for the Fast Read Dual Output instructions (3Bh)

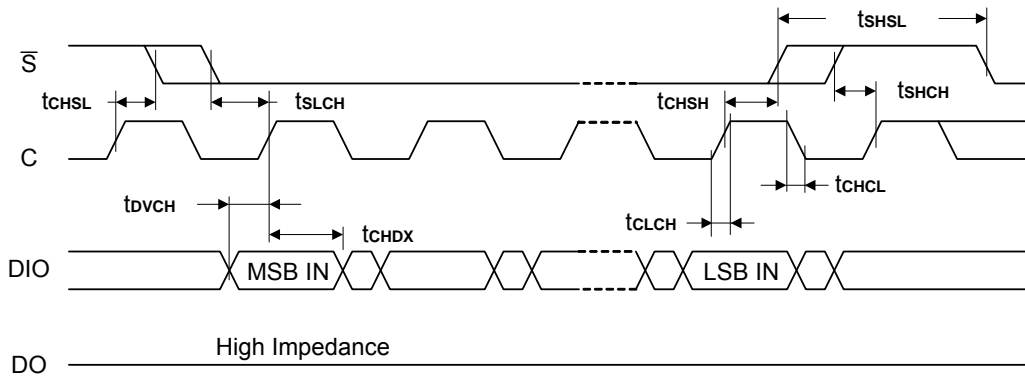
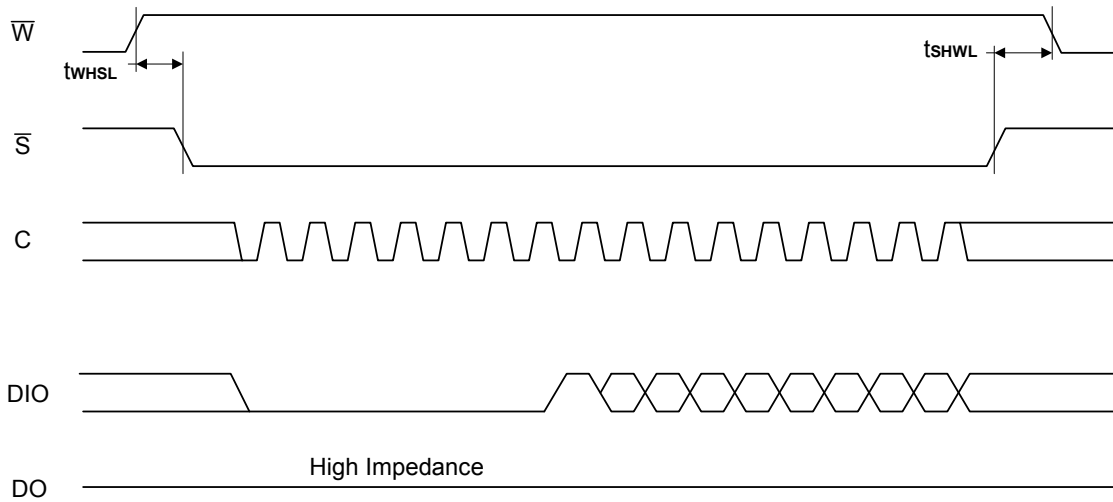
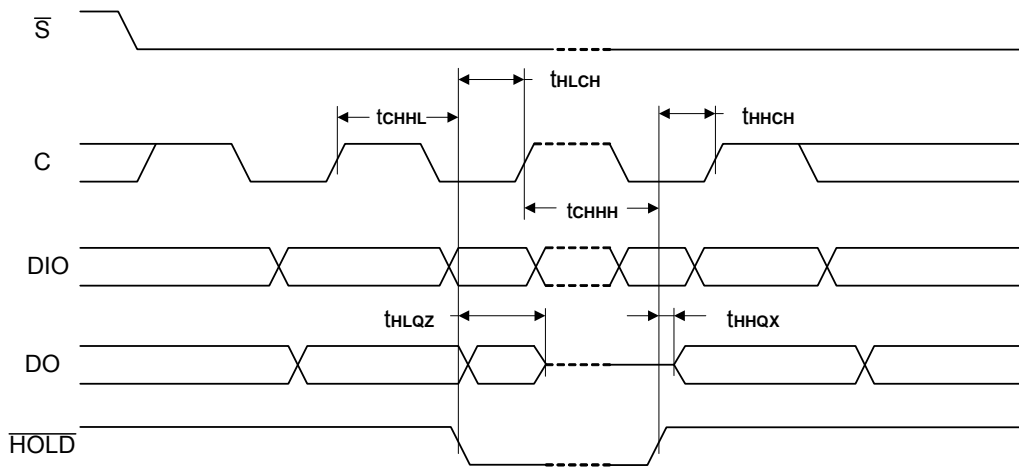
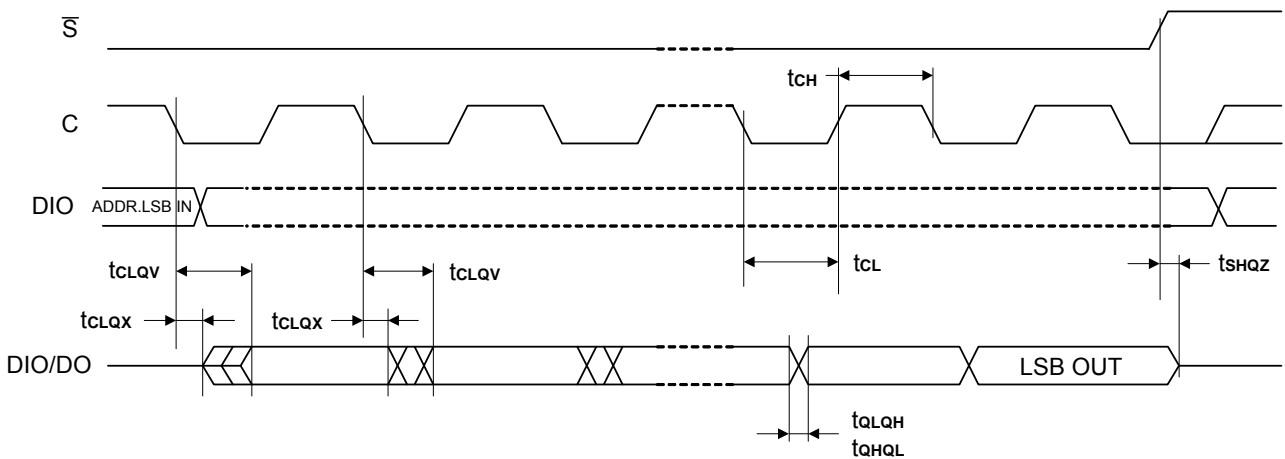
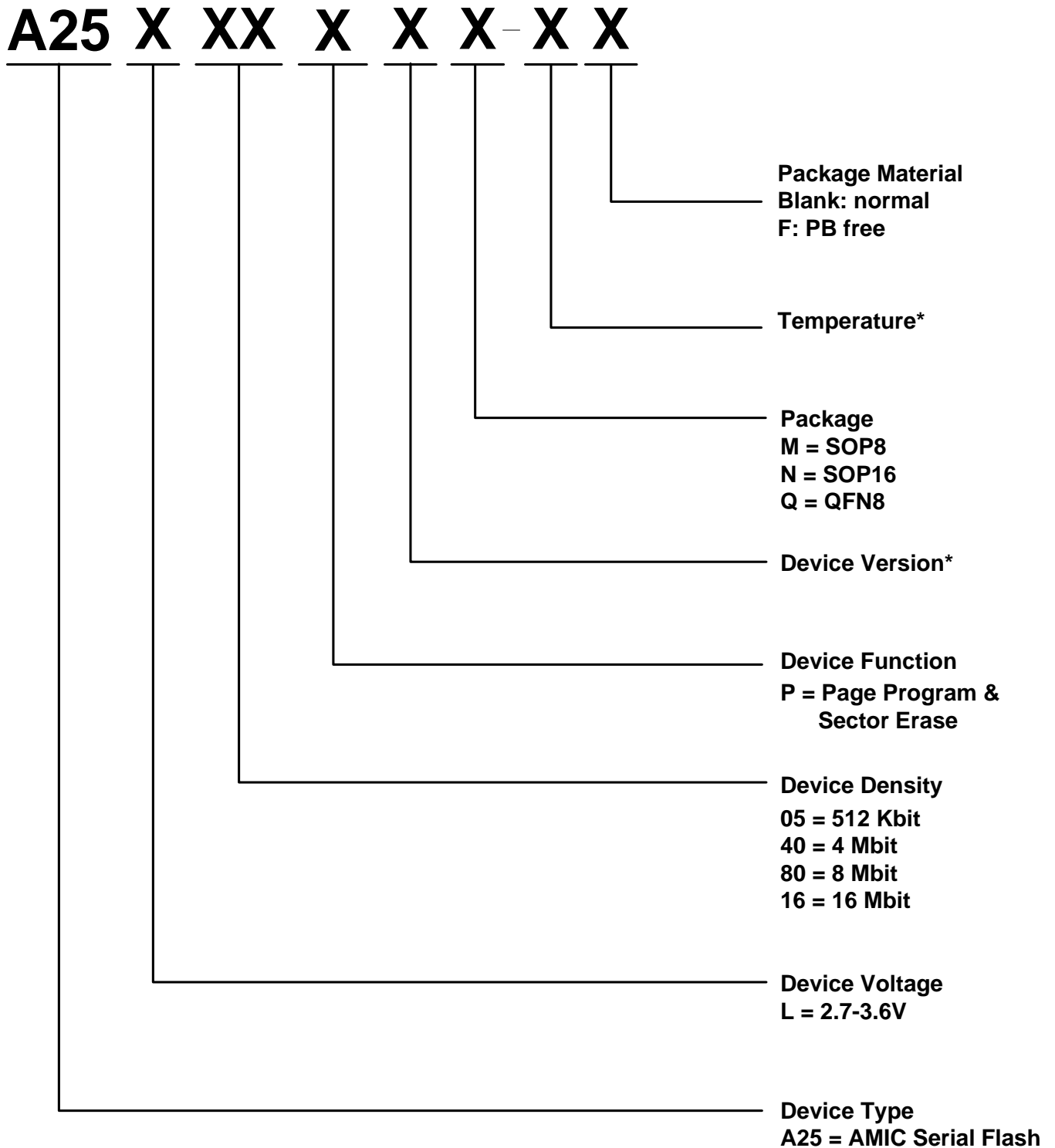
Part Numbering Scheme

*** Optional**

Ordering Information

Part No.	Speed (MHz)	Active Read Current Typ. (mA)	Program/Erase Current Typ. (mA)	Standby Current Typ. (μ A)	Package
A25L16PTM-F	85	20	15	10	8 Pb-Free Pin SOP (209mil)
A25L16PTM-UF					8 Pb-Free Pin SOP (209mil)
A25L16PTN-F					16 Pin Pb-Free SOP
A25L16PTN-UF					16 Pin Pb-Free SOP
A25L16PTQ-F					8 Pin Pb-Free QFP
A25L16PTQ-UF					8 Pin Pb-Free QFP
A25L16PUM-F	85	20	15	10	8 Pb-Free Pin SOP (209mil)
A25L16PUM-UF					8 Pb-Free Pin SOP (209mil)
A25L16PUN-F					16 Pin Pb-Free SOP
A25L16PUN-UF					16 Pin Pb-Free SOP
A25L16PUQ-F					8 Pin Pb-Free QFP
A25L16PUQ-UF					8 Pin Pb-Free QFP

-U is for industrial operating temperature range: $-40^{\circ}\text{C} \sim +85^{\circ}\text{C}$

Package Information
SOP 8L (209mil) Outline Dimensions

unit: mm

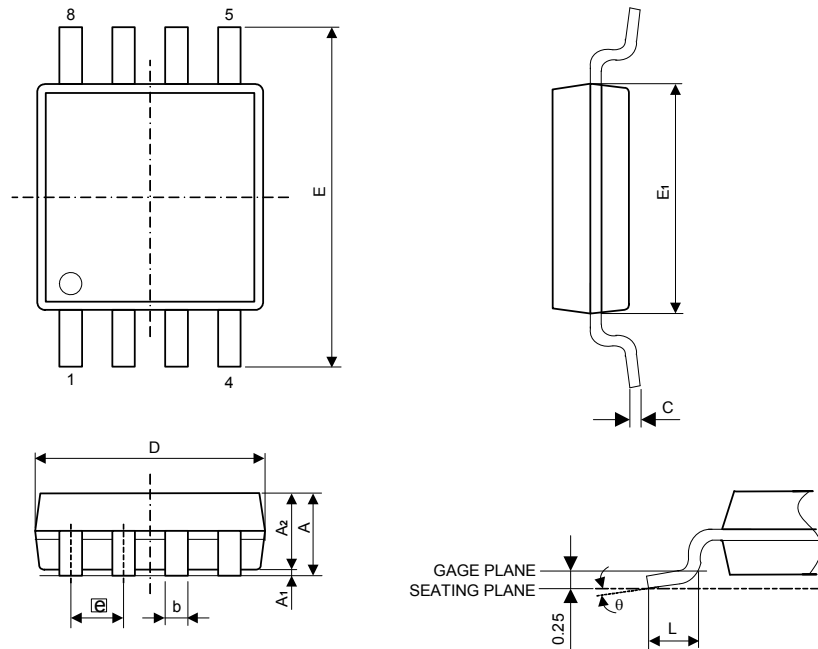

Symbol	Dimensions in mm		
	Min	Nom	Max
A	1.75	1.95	2.16
A1	0.05	0.15	0.25
A2	1.70	1.80	1.91
b	0.35	0.42	0.48
C	0.19	0.20	0.25
D	5.13	5.23	5.33
E	7.70	7.90	8.10
E1	5.18	5.28	5.38
\square e	1.27 BSC		
L	0.50	0.65	0.80
θ	0°	-	8°

Notes:

Maximum allowable mold flash is 0.15mm at the package ends and 0.25mm between leads

Package Information
SOP 16L (300mil) Outline Dimensions

unit: inch

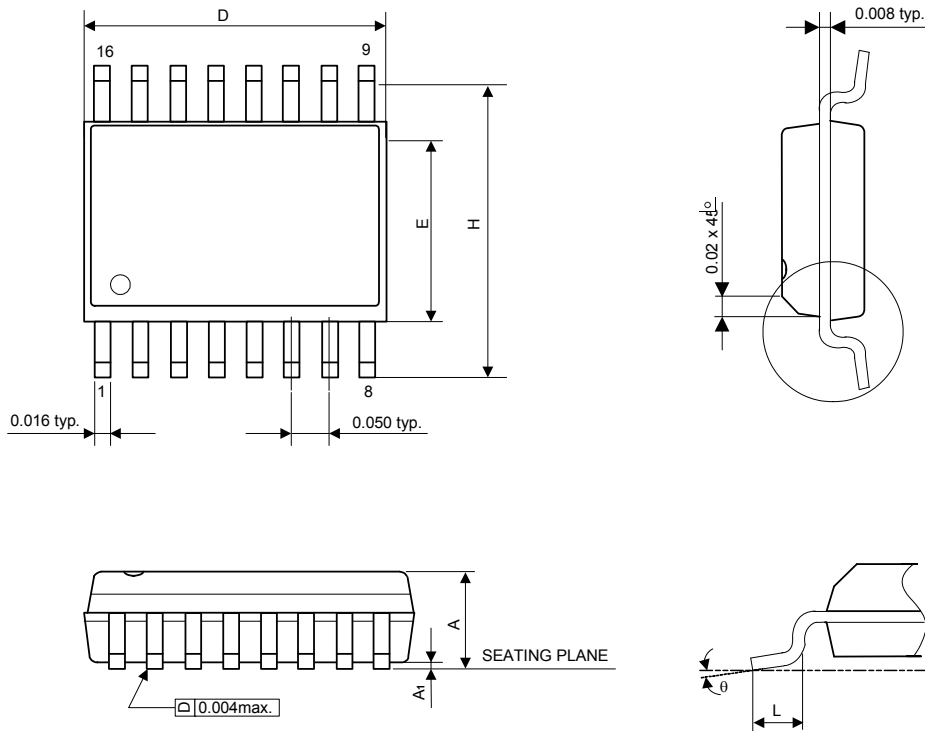

Symbol	Dimensions in inch	
	Min	Max
A	0.093	0.104
A1	0.004	0.012
D	0.398	0.413
E	0.291	0.299
H	0.394	0.419
L	0.016	0.050
θ	0°	8°

Notes:

1. Dimensions "D" does not include mold flash, protrusions or gate burrs.
2. Dimensions "E" does not include interlead flash, or protrusions.

Package Information
QFN 8L (6 X 5 X 0.8mm) Outline Dimensions

unit: mm/mil

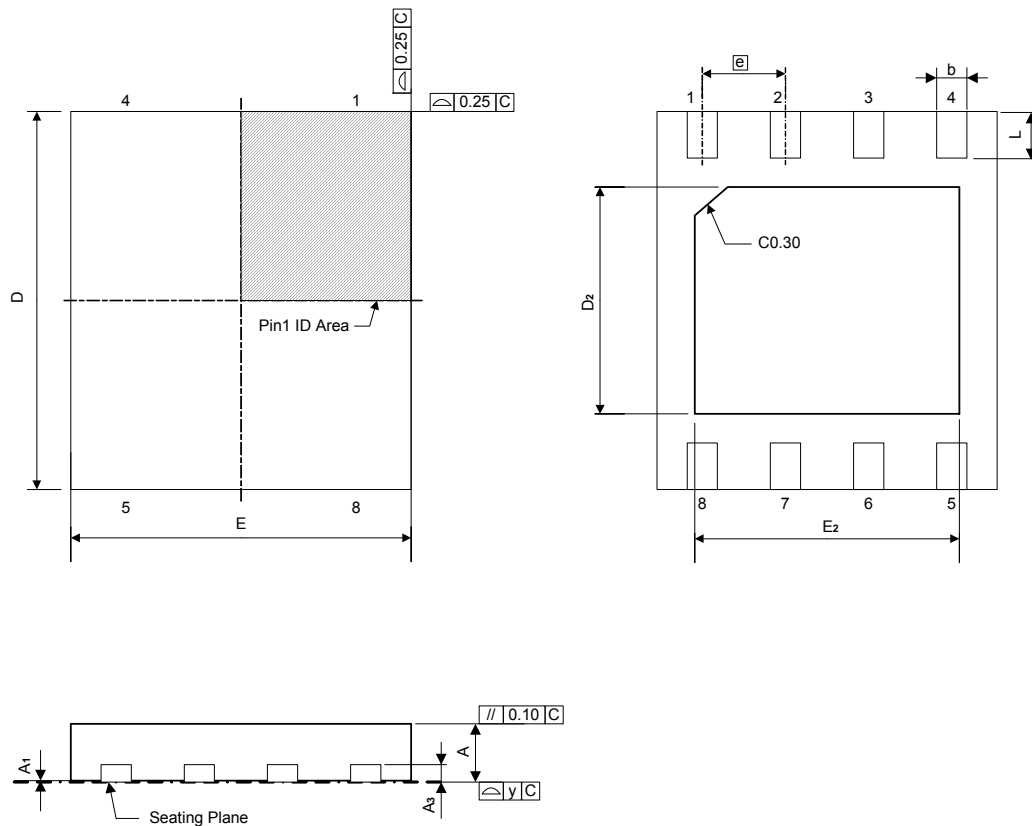

Symbol	Dimensions in mm			Dimensions in mil		
	Min	Nom	Max	Min	Nom	Max
A	0.700	0.750	0.800	27.6	29.5	31.5
A ₁	0.000	0.020	0.050	0.0	0.8	2.0
A ₃	0.203 REF			8.0 REF		
b	0.350	0.400	0.480	13.8	15.8	18.9
D	5.900	6.000	6.100	232.3	236.2	240.2
D ₂	3.200	3.400	3.600	126.0	133.9	141.7
E	4.900	5.000	5.100	192.9	196.9	200.8
E ₂	3.800	4.000	4.200	149.6	157.5	165.4
L	0.500	0.600	0.750	19.7	23.6	29.5
[e]	1.270 BSC			50.0 BSC		
y	0	-	0.080	0	-	3.2

Note:

1. Controlling dimension: millimeters
2. Leadframe thickness is 0.203mm (8mil)