



1N5400~1N5408

HIGH CURRENT PLASTIC SILICON RECTIFIER

VOLTAGE 50 to 1000 Volts **CURRENT** 3.0 Ampere

DO-201AD Unit: inch(mm)

FEATURES

- Plastic package has Underwriters Laboratories Flammability Classification 94V-O utilizing Flame Retardant Epoxy Molding Compound.
- High current capability
- Low leakage
- Exceeds environmental standards of MIL-S-19500/228
- In compliance with EU RoHS 2002/95/EC directives

MECHANICAL DATA

- Case: DO-201AD Molded plastic
- Lead: Axial leads, solderable per MIL-STD-750, Method 2026 guaranteed
- Polarity: Color band denotes cathode end
- Mounting Position: Any
- Weight: 0.04 ounces, 1.1 gram

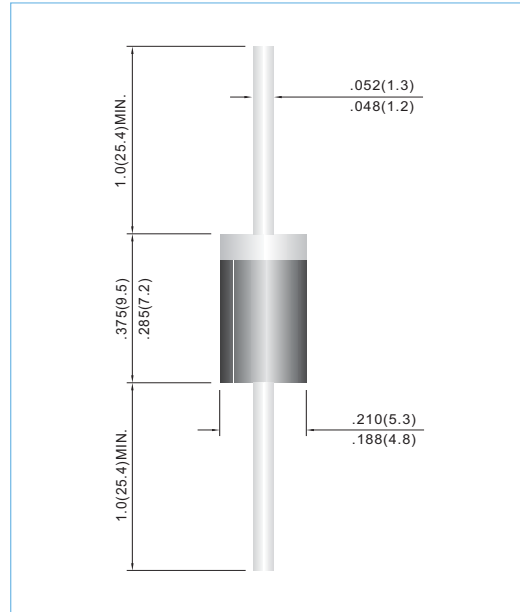

MAXIMUM RATINGS AND ELECTRICAL CHARACTERISTICS

Ratings at 25°C ambient temperature unless otherwise specified. Single phase, half wave, 60 Hz, resistive or inductive load. For capacitive load, derate current by 20%.

PARAMETER	SYMBOL	1N5400	1N5401	1N5402	1N5403	1N5404	1N5405	1N5406	1N5407	1N5408	UNITS
Maximum Recurrent Peak Reverse Voltage	V_{RRM}	50	100	200	300	400	500	600	800	1000	V
Maximum RMS Voltage	V_{RMS}	35	70	140	210	280	350	420	560	700	V
Maximum DC Blocking Voltage	V_{DC}	50	100	200	300	400	500	600	800	1000	V
Maximum Average Forward Current .375"(9.5mm) lead length at $T_A=55^\circ\text{C}$	$I_{F(AV)}$	3.0									A
Peak Forward Surge Current : 8.3ms single half sine-wave superimposed on rated load(JEDEC method)	I_{FSM}	200									A
Maximum Forward Voltage at 3.0A	V_F	1.2									V
Maximum DC Reverse Current at $T_J=25^\circ\text{C}$ Rated DC Blocking Voltage $T_J=100^\circ\text{C}$	I_R	5.0 1000									μA
Typical Junction capacitance (Note 1)	C_J	30									pF
Typical Thermal Resistance(Note 2)	$R_{\theta JA}$	20									$^\circ\text{C} / \text{W}$
Operating Junction and Storage Temperature Range	T_J, T_{STG}	-55 TO +150									$^\circ\text{C}$

NOTES:

1. Measured at 1 MHz and applied reverse voltage of 4.0 VDC.
2. Thermal Resistance from Junction to Ambient and from junction to lead at 0.375"(9.5mm)lead length P.C.B.mounted.



1N5400~1N5408

RATING AND CHARACTERISTIC CURVES

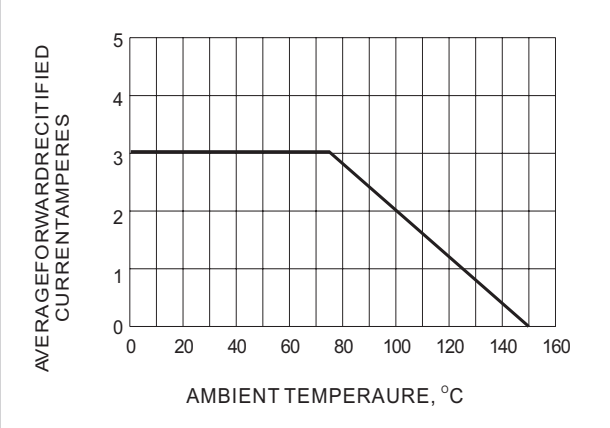

Fig.1- FORWARD CURRENT DERATING CURVE

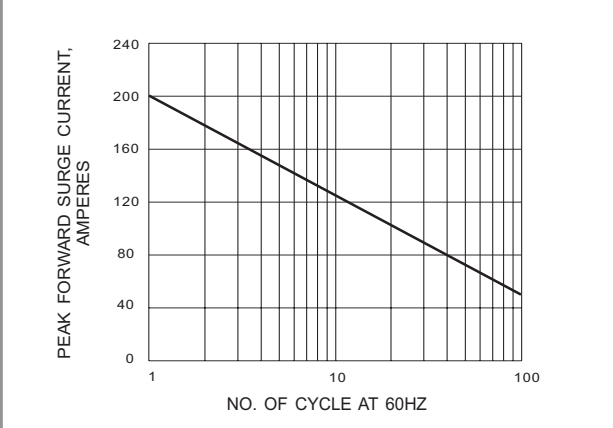

Fig.2- MAXIMUM NON - REPETITIVE SURGE CURRENT

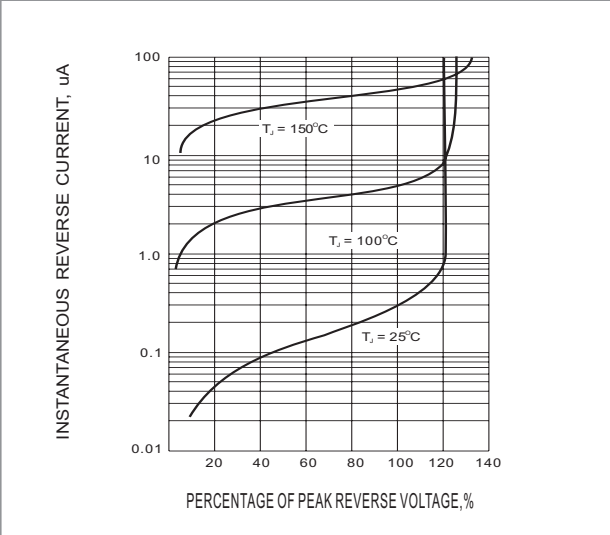

Fig.3- TYPICAL REVERSE CHARACTERISTIC

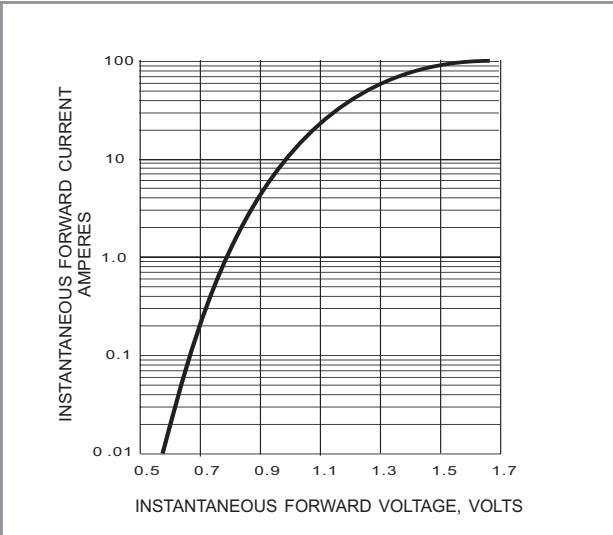

Fig.4- TYPICAL INSTANTANEOUS FORWARD CHARACTERISTIC

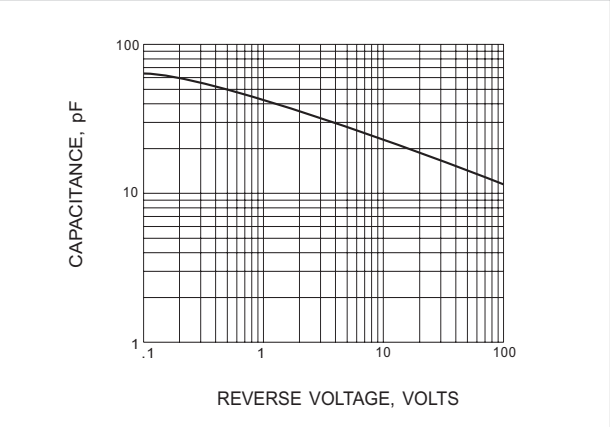

Fig.5- TYPICAL JUNCTION CAPACITANCE