

ALUMINUM ELECTROLYTIC CAPACITORS

UH series Chip Type, High Reliability, Higher Capacitance Range

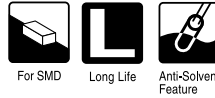

- Chip Type, higher capacitance in larger case sizes (φ12.5, φ16, φ18, φ20)
- Designed for surface mounting on high density PC board.
- Applicable to automatic mounting machine using carrier tape and tray.
- Adapted to the RoHS directive (2002/95/EC).

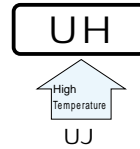

Specifications

Item	Performance Characteristics							
Category Temperature Range	-55 ~ +125°C							
Rated Voltage Range	10 ~ 50V							
Rated Capacitance Range	100 ~ 3300μF							
Capacitance Tolerance	±20% at 120Hz, 20°C							
Leakage Current	After 1 minutes' application of rated voltage, leakage current is not more than 0.03CV or 4 (μA), whichever is greater.							
tan δ	Rated voltage (V)	10	16	25	35	50	120Hz 20°C	
	tan δ (MAX)	0.22	0.18	0.16	0.14	0.12		
For capacitance of more than 1000μF, add 0.02 for every increase of 1000μF.								
Stability at Low Temperature	Rated voltage (V)	10	16	25	35	50	120Hz	
	Impedance ratio ZT / Z20 (MAX.)	Z-25°C / Z+20°C	4	3	2	2		2
		Z-40°C / Z+20°C	8	6	4	3	3	
Endurance	After 5000 hours' application of rated voltage at 125°C, capacitors meet the characteristic requirements listed at right.						Capacitance change	Within ±30% of initial value
						tan δ	300% or less of initial specified value	
						Leakage current	Initial specified value or less	
Shelf Life	After storing the capacitors under no load at 125°C for 1000 hours, and after performing voltage treatment based on JIS C 5101-4 clause 4.1 at 20°C, they will meet the specified value for endurance characteristics listed above.							
Marking	Black print on the case top.							

Chip Type

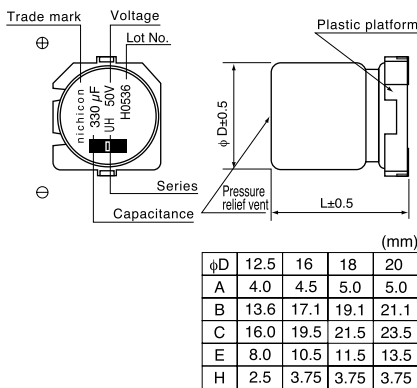

The lead terminal structure : The same bent lead type (refer to p.60) that is currently used on 10mm diameter and smaller parts, is also available upon request. In this case of the bent lead type, □ will be put at the 11th digit of type numbering system. Please ask for details.

Type numbering system (Example : 50V 330μF)

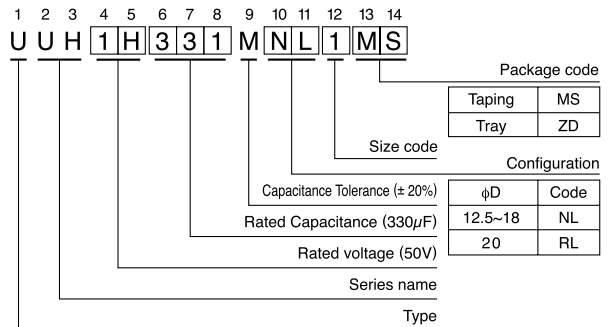

Dimensions

Cap. (μF)	Code	10		16		25		35		50	
		1A		1C		1E		1V		1H	
100	101									12.5 × 13.5	170
220	221							12.5 × 13.5	200	16 × 16.5	250
330	331			12.5 × 13.5	210	12.5 × 13.5	230	16 × 16.5	280	16 × 21.5	340
										▲ 18 × 16.5	340
470	471	12.5 × 13.5	230	12.5 × 13.5	250	16 × 16.5	310	18 × 16.5	380	18 × 21.5	430
								▲ 16 × 21.5	380		
1000	102	12.5 × 16	350	16 × 16.5	440	18 × 21.5	540	20 × 21.5	610		
						▲ 20 × 16.5	540				
2200	222	18 × 16.5	620	18 × 21.5	710						
		▲ 16 × 21.5	620								
3300	332	18 × 21.5	770								
										Case size φD × L (mm)	Rated Ripple

* In this case, [6] will be put at 12th digit of type numbering system, "▲"

Rated Ripple (mArms) at 125°C 120Hz

Frequency coefficient of rated ripple current

Cap.(μF)	Frequency	50 Hz	120 Hz	300 Hz	1 kHz	10 kHz~
100 ~ 470		0.80	1.00	1.23	1.34	1.50
1000 ~ 3300		0.85	1.00	1.10	1.13	1.15

- Taping specifications are given in page 24.
- Recommended land size, soldering by reflow are given in page 25, 26.
- Please refer to page 3 for the minimum order quantity.