

TOSHIBA

TOSHIBA Original CMOS 16-Bit Microcontroller

TLCS-900/L Series

TMP93PS44

TOSHIBA CORPORATION

Semiconductor Company

Preface

Thank you very much for making use of Toshiba microcomputer LSIs.
Before use this LSI, refer the section, "Points of Note and Restrictions".
Especially, take care below cautions.

****CAUTION****

How to release the HALT mode

Usually, interrupts can release all halts status. However, the interrupts = ($\overline{\text{NMI}}$, INT0), which can release the HALT mode may not be able to do so if they are input during the period CPU is shifting to the HALT mode (for about 3 clocks of f_{FPH}) with IDLE1 or STOP mode (IDLE2/RUN are not applicable to this case). (In this case, an interrupt request is kept on hold internally.)

If another interrupt is generated after it has shifted to HALT mode completely, halt status can be released without difficulty. The priority of this interrupt is compare with that of the interrupt kept on hold internally, and the interrupt with higher priority is handled first followed by the other interrupt.

Low Voltage/Low Power

CMOS 16-Bit Microcontroller TMP93PS44F

1. Outline and Device Characteristics

The TMP93PS44 is OTP type MCU which includes 64-Kbyte one-time PROM. Using the adapter socket, you can write and verify the data for the TMP93PS44. The TMP93PS44 has the same pin assignment as TMP93CS44 (Mask ROM type).

Writing the program to built-in PROM, the TMP93PS44 operates as the same way as the TMP93CS44.

MCU	ROM	RAM	Package	Adapter Socket
TMP93PS44F	OTP 64 Kbytes	2 Kbytes	P-LQFP80-1212-0.50E	BM11128

030619EBP1

- The information contained herein is subject to change without notice.
- The information contained herein is presented only as a guide for the applications of our products. No responsibility is assumed by TOSHIBA for any infringements of patents or other rights of the third parties which may result from its use. No license is granted by implication or otherwise under any patent or patent rights of TOSHIBA or others.
- TOSHIBA is continually working to improve the quality and reliability of its products. Nevertheless, semiconductor devices in general can malfunction or fail due to their inherent electrical sensitivity and vulnerability to physical stress. It is the responsibility of the buyer, when utilizing TOSHIBA products, to comply with the standards of safety in making a safe design for the entire system, and to avoid situations in which a malfunction or failure of such TOSHIBA products could cause loss of human life, bodily injury or damage to property.
In developing your designs, please ensure that TOSHIBA products are used within specified operating ranges as set forth in the most recent TOSHIBA products specifications. Also, please keep in mind the precautions and conditions set forth in the "Handling Guide for Semiconductor Devices," or "TOSHIBA Semiconductor Reliability Handbook" etc..
- The TOSHIBA products listed in this document are intended for usage in general electronics applications (computer, personal equipment, office equipment, measuring equipment, industrial robotics, domestic appliances, etc.). These TOSHIBA products are neither intended nor warranted for usage in equipment that requires extraordinarily high quality and/or reliability or a malfunction or failure of which may cause loss of human life or bodily injury ("Unintended Usage"). Unintended Usage include atomic energy control instruments, airplane or spaceship instruments, transportation instruments, traffic signal instruments, combustion control instruments, medical instruments, all types of safety devices, etc.. Unintended Usage of TOSHIBA products listed in this document shall be made at the customer's own risk.
- The products described in this document are subject to the foreign exchange and foreign trade laws.
- TOSHIBA products should not be embedded to the downstream products which are prohibited to be produced and sold, under any law and regulations.
- For a discussion of how the reliability of microcontrollers can be predicted, please refer to Section 1.3 of the chapter entitled Quality and Reliability Assurance/Handling Precautions.



Purchase of TOSHIBA I²C components conveys a license under the Philips I²C Patent Rights to use these components in an I²C system, provided that the system conforms to the I²C Standard Specification as defined by Philips.

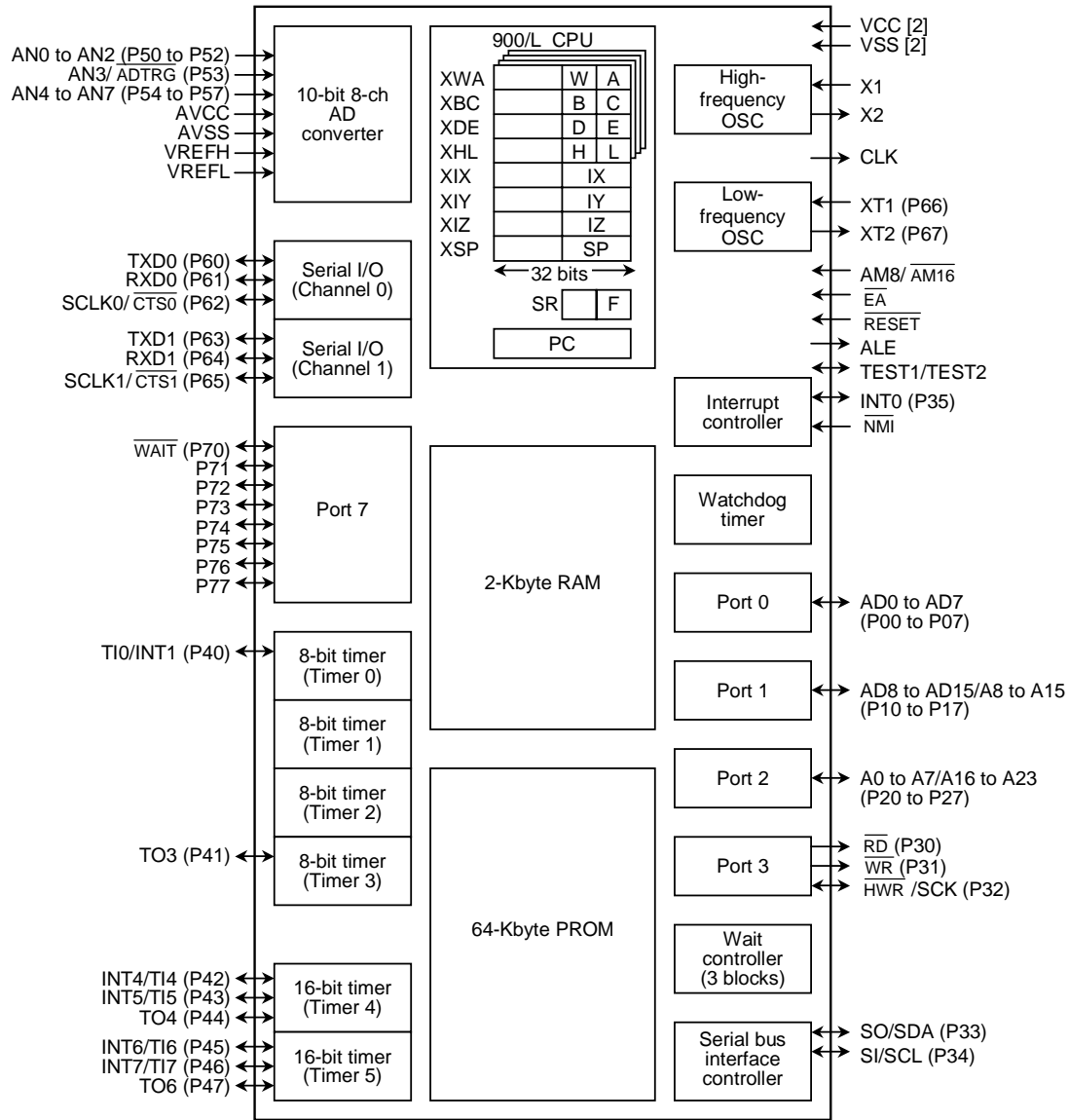

Note: The items in parentheses () are the initial setting after reset.

Figure 1.1 TMP93PS44 Block Diagram

2. Pin Assignment and Functions

The assignment of input/output pins for the TMP93PS44, their names and outline functions are described below.

2.1 Pin Assignment

Figure 2.1.1 shows pin assignment of the TMP93PS44F.

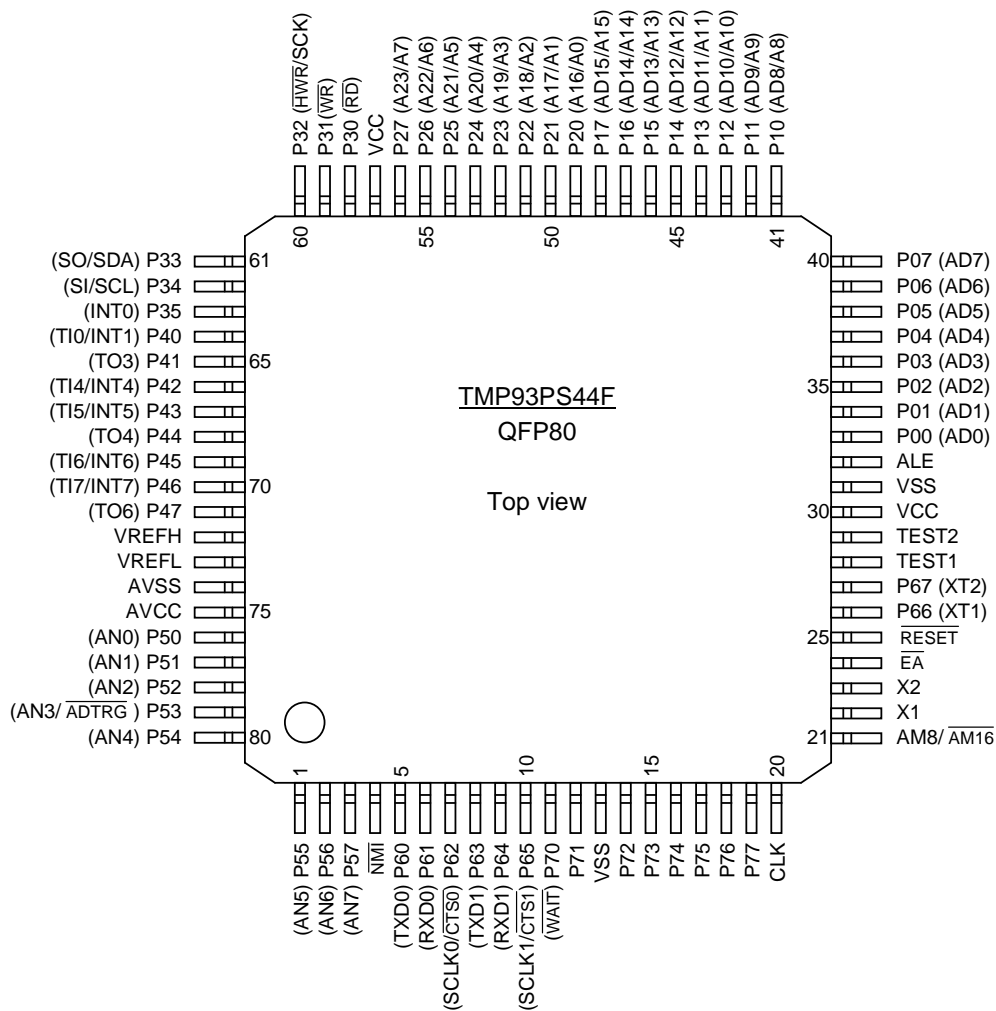

Figure 2.1.1 Pin Assignment (P-LQFP80-1212-0.50E)

2.2 Pin Names and Functions

The TMP93PS44 has MCU mode and PROM mode.

(1) Table 2.2.1 shows pin functions of TMP93PS44 in MCU mode.

Table 2.2.1 Pin Names and Functions (1/3)



Pin Name	Number of Pins	I/O	Functions
P00 to P07 AD0 to AD7	8	I/O	Port 0: I/O port that allows selection of I/O on a bit basis
		3-state	Address/data (Lower): Bits 0 to 7 for address/data bus
P10 to P17 AD8 to AD15 A8 to A15	8	I/O	Port 1: I/O port that allows selection of I/O on a bit basis
		3-state	Address/data (Upper): Bits 8 to 15 for address/data bus
		Output	Address: Bits 8 to 15 for address bus
P20 to P27 A0 to A7 A16 to A23	8	I/O	Port 2: I/O port that allows selection of I/O on a bit basis (with pull-up resistor)
		Output	Address: Bits 0 to 7 for address bus
		Output	Address: Bits 16 to 23 for address bus
P30 RD	1	Output	Port 30: Output port
		Output	Read: Strobe signal for reading external memory
P31 WR	1	Output	Port 31: Output port
		Output	Write: Strobe signal for writing data on pins AD0 to AD7
P32 HWR SCK	1	I/O	Port 32: I/O port (with pull-up resistor)
		Output	High write: Strobe signal for writing data on pins AD8 to AD15
		I/O	Mode clock SBI SIO mode clock
P33 SO SDA	1	I/O	Port 33: I/O port
		Output	Serial send data
		I/O	SBI I ² C bus mode channel data
P34 SI SCL	1	I/O	Port 34: I/O port
		Input	Serial receive data
		I/O	SBI I ² C bus mode clock
P35 INT0	1	I/O	Port 35: I/O port
		Input	Interrupt request pin 0: Interrupt request pin with programmable level/rising edge 
P40 TI0 INT1	1	I/O	Port 40: I/O port
		Input	Timer input 0: Timer 0 input
P41 TO3	1	Input	Interrupt request pin 1: Interrupt request pin with rising edge 
		Output	PWM output 3: 8-bit PWM timer 3 output
P42 TI4 INT4	1	I/O	Port 42: I/O port
		Input	Timer input 4: Timer 4 count/capture trigger signal input
		Input	Interrupt request pin 4: Interrupt request pin with programmable rising/falling edge 

Table 2.2.2 Pin Names and Functions (2/3)

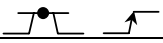

Pin Name	Number of Pins	I/O	Functions
P43	1	I/O	Port 43: I/O port
Ti5		Input	Timer input 5: Timer 4 count/capture trigger signal input
INT5		Input	Interrupt request pin 5: Interrupt request pin with rising edge 
P44	1	I/O	Port 44: I/O port
TO4		Output	Timer output 4: Timer 4 output
P45	1	I/O	Port 45: I/O port
Ti6		Input	Timer input 6: Timer 5 count/capture trigger signal input
INT6		Input	Interrupt request pin 6: Interrupt request pin with programmable rising/falling edge 
P46	1	I/O	Port 46: I/O port
Ti7		Input	Timer input 7: Timer 5 count/capture trigger signal input
INT7		Input	Interrupt request pin 7: Interrupt request pin with rising edge 
P47	1	I/O	Port 47: I/O port
TO6		Output	Timer output 6: Timer 5 output pin
P50 to P52, P54 to P57	7	Input	Port 50 to 52, port 54 to 57: Input port
AN0 to AN2, AN4 to AN7		Input	Analog input: Analog signal input for AD converter
P53	1	Input	Port 53: Input port
AN3		Input	Analog input: Analog signal input for AD converter
ADTRG		Input	AD converter external start trigger input
P60	1	I/O	Port 60: I/O port (with pull-up resistor)
TXD0		Output	Serial send data 0
P61	1	I/O	Port 61: I/O port (with pull-up resistor)
RXD0		Input	Serial receive data 0
P62	1	I/O	Port 62: I/O port (with pull-up resistor)
CTS0		I/O	Serial clock I/O 0
SCLK0		Input	Serial data send enable 0 (Clear to send)
P63	1	I/O	Port 63: I/O port (with pull-up resistor)
TXD1		Output	Serial send data 1
P64	1	I/O	Port 64: I/O port (with pull-up resistor)
RXD1		Input	Serial receive data 1
P65	1	I/O	Port 65: I/O port (with pull-up resistor)
CTS1		I/O	Serial clock I/O 1
SCLK1		Input	Serial data send enable 1 (Clear to send)
P66	1	I/O	Port 66: I/O port (Open-drain output)
XT1		Input	Low-frequency oscillator connecting pin
P67	1	I/O	Port 67: I/O port (Open-drain output)
XT2		Output	Low-frequency oscillator connecting pin

Table 2.2.3 Pin Names and Functions (3/3)

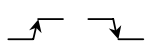
Pin Name	Number of Pins	I/O	Functions
P70 $\overline{\text{WAIT}}$	1	I/O	Port 70: I/O port (High current output available)
		Input	$\overline{\text{WAIT}}$: Pin used to request CPU bus wait (It is active in (1 + N) $\overline{\text{WAIT}}$ mode. Set by the bus-width/wait control register.)
P71 to P77	7	I/O	Port 71 to 77: I/O port (High current output available)
AVCC	1	Input	Power supply pin for AD converter
AVSS	1	Input	GND pin for AD converter (0 V)
VREFH	1	Input	Pin for high level reference voltage input to AD converter
VREFL	1	Input	Pin for low level reference voltage input to AD converter
$\overline{\text{NMI}}$	1	Input	Non-maskable interrupt request pin: Interrupt request pin with falling edge. Can also be operated at falling and rising edges by program. 
X1	1	Input	High-frequency oscillator connecting pin
X2	1	Output	High-frequency oscillator connecting pin
$\overline{\text{RESET}}$	1	Input	Reset: Initializes TMP93PS44. (with pull-up resistor)
ALE	1	Output	Address latch enable Can be disabled for reducing noise.
CLK	1	Output	Clock output: Outputs " $f_{\text{SYS}} \div 2$ " clock. Pulled-up during reset. Can be disabled for reducing noise.
$\overline{\text{EA}}$	1	Input	External access: "1" should be inputted
AM8/ $\overline{\text{AM16}}$	1	Input	Address Mode: Selects external data bus width. "1" should be inputted. The data bus width for external access is set by chip select/ $\overline{\text{WAIT}}$ control register, port 1 control register.
VCC	2	Input	Power supply pin
VSS	2	Input	GND pin (All VSS pins are connected to the GND (0 V).)
TEST1/TEST2	2	Output/Input	TEST1 should be connected with TEST2 pin. Do not connect to any other pins.

Note: Built-in pull-up resistors can be released from the pins other than the $\overline{\text{RESET}}$ pin by software.

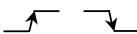
(2) PROM mode

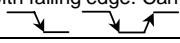
Table 2.2.4 shows pin functions of the TMP93PS44 in PROM mode.

Table 2.2.4 Pin Names and Functions of PROM Mode

Pin Function	Number of Pins	Input/Output	Function	Pin Name (MCU Mode)
A7 to A0	8	Input	Memory address of program	P27 to P20
A15 to A8	8	Input		P17 to P10
A16	1	Input		P33
D7 to D0	8	I/O	Memory data of program	P07 to P00
\overline{CE}	1	Input	Chip enable	P32
\overline{OE}	1	Input	Output control	P30
\overline{PGM}	1	Input	Program control	P31
VPP	1	Power supply	12.75 V/5 V (Power supply of program)	\overline{EA}
VCC	3	Power supply	6.25 V/5 V	VCC, AVCC
VSS	3	Power supply	0 V	VSS, AVSS
Pin Function	Number of Pins	Input/Output	Disposal of Pin	
P60	1	Input	Fix to low level (Security pin)	
\overline{RESET}	1	Input	Fix to low level (PROM mode)	
CLK	1	Input		
ALE	1	Output	Open	
X1	1	Input	Self oscillation with resonator	
X2	1	Output		
P66 to P61 AM8/ AM16	7	Input	Fix to high level	
TEST1/TEST2	2	Input/Output	TEST1 should be connected with TEST2 pin. Do not connect to any other pins.	
P35, P34 P47 to P40 P57 to P50 P67 P77 to P70 VREFH VREFL \overline{NMI}	30	I/O	Open	

3. Operation

This section describes the functions and basic operational blocks of the TMP93PS44.

The TMP93PS44 has PROM in place of the mask ROM which is included in the TMP93CS44. The other configuration and functions are the same as the TMP93CS44. Regarding the function of the TMP93PS44 (Not described), see the part of TMP93CS44.

The TMP93PS44 has two operational modes: MCU mode and PROM mode.

3.1 MCU Mode

(1) Mode-setting and function

The MCU mode is set by opening the CLK pin (Pin open). In the MCU mode, the operation is same as TMP93CS44.

(2) Memory map

The memory map of TMP93PS44 is same as that of TMP93CS44. Figure 3.1.1 shows the memory map in MCU mode. Figure 3.1.2 show that in PROM mode.

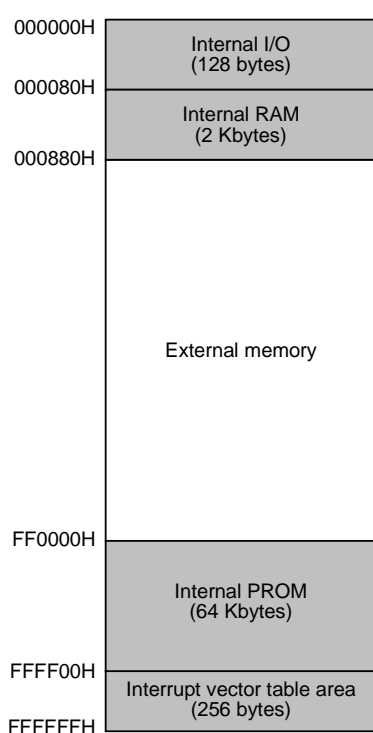

Figure 3.1.1 Memory Map in MCU Mode

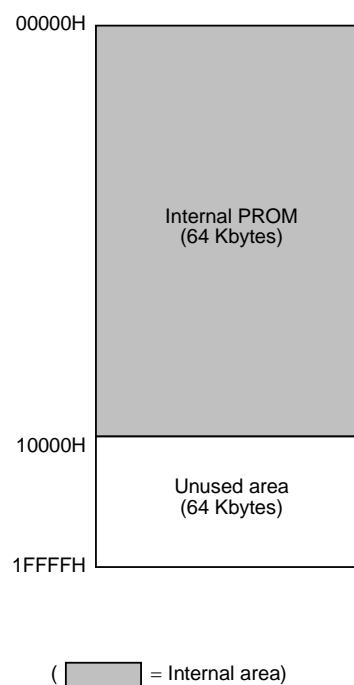

Figure 3.1.2 Memory Map in PROM Mode

3.2 PROM Mode

(1) Mode setting and function

PROM mode is set by setting the $\overline{\text{RESET}}$ and CLK pins to the “L” level. The programming and verification for the internal PROM is achieved by using a general EPROM programmer with the adaptor socket.

1. Preparation of OTP adaptor

BM11128: for TMP93PS44F

2. Setting of OTP adaptor

The switch (SW1) is set to N side.

3. Setting of PROM writer

i) Set PROM type to TC 571000D.

Size: 1 Mbits (128 K × 8 bits)

VPP: 12.75 V

tPW: 100 μs

Electric signature mode: None

ii) Data transmission

In TMP93PS44, PROM is placed on addresses 00000 to 0FFFFH in PROM mode, and addresses FF0000H to FFFFFFFH in MCU mode. Therefore data should be transferred to addresses 00000 to 0FFFFH in PROM mode using the object converter (tuconv) or the block transfer mode. (See instruction manual of PROM programmer.)

iii) Setting of the program address

Start address: 00000H

End address: 0FFFFH

Using PROM programmer which can not set the programming address, set FFH at addresses 10000H to 1FFFFH.

4. Programming

Program and verify according to operating process of PROM programmer.

Figure 3.2.1 shows the setting of the pins in PROM mode.

Figure 3.2.1 shows the setting of pins in PROM mode.

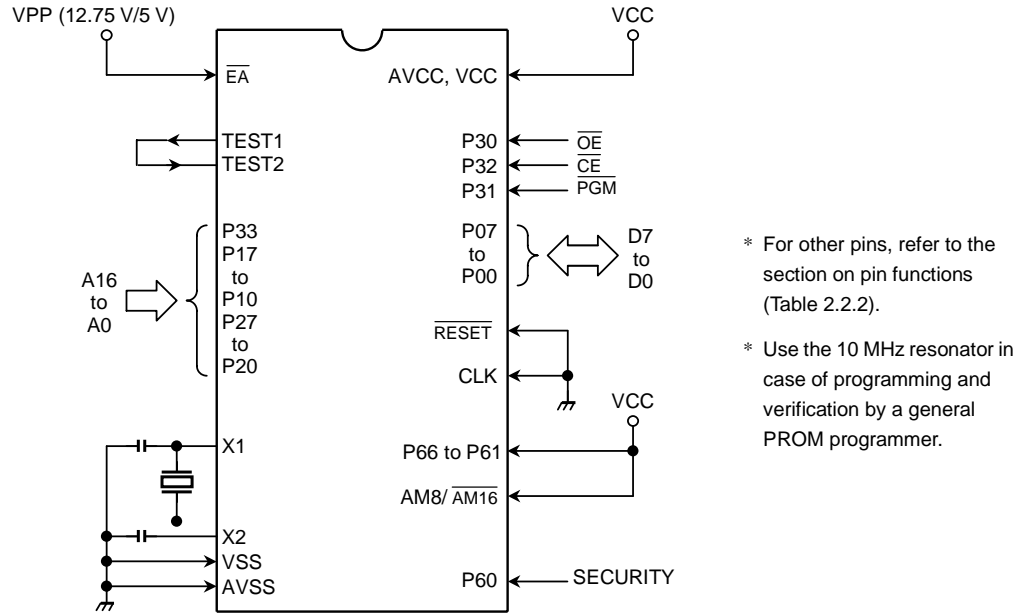

Figure 3.2.1 PROM Mode Pin Setting

(2) Caution for electric signature

The TMP93PS44 does not support the electric signature mode (Hereinafter referred to as “signature”). If PROM programmer used the signature, the device would be damaged because of applying voltage of 12 ± 0.5 V to pin 9 (A9) of the address.

Please use without setting the signature.

(3) Program mode

All bits of the TMP93PS44 are “1” when delivered (The erase state). Data “0” is written in the necessary bit location during program operating.

Writing function can be operated at $V_{PP} = 12.5$ V, $\overline{OE} = V_{IH}$, $\overline{CE} = V_{IL}$. Built-in one time PROM can be written in any sequence. It is possible to write only special address.

(4) Adopter socket (BM11128: for TMP93PS44)

BM11128 is the adapter sockets to write data into the TMP93PS44. The TMP93PS44 has built-in one time PROM using a general EPROM programmer.

(5) Program storing area of PROM mode

The TMP93PS44 has the program space (FF0000H to FFFFFFFH) of 64 Kbytes. The address 0000H to FFFFH of PROM mode equals to the address FF0000H to FFFFFFFH of MCU mode.

(6) Program write setting method using a general PROM programmer

PROM to be prepared should equal to TC571000D functions.

1. Set the switch (SW1) of BM11128 (hereinafter referred to as “adapter”) to the program side (NOR) (Note 1).
2. Connect MCU to the adapter (Note 2).
3. Connect the adapter to PROM programmer (Note 2).
4. Set the PROM type of PROM programmer to TC571000D.
5. Set the start address for writing PROM to 0000H, and the end address to FFFFH (Note 3).
6. Writing to built-in one time PROM and verifying should be operated according to the operation procedures of PROM programmer.

Note 1: If data is written to built-in one time PROM without setting the switch (SW1) to the program side, the device would be damaged.

Note 2: Please set with the first pin of the adapter and that of PROM programmer socket matched. If the first pin is conversely set, MCU or programmer would be damaged.

Note 3: If data “0” is written to the address which is over FFFFH, the contents of the original program would be damaged because of writing “0” to the addresses 0000H to FFFFH.

(7) Programming flow chart

The programming mode is set by applying 12.75 V (Programming voltage) to the VPP pin when the following pins are set as follows,

(VCC: 6.25 V, $\overline{\text{RESET}}$: “L” level, CLK: “L” level).

While address and data are fixed and $\overline{\text{CE}}$ pin is set to “L” level, 0.1 ms of “L” level pulse is applied to $\overline{\text{PGM}}$ pin to program the data.

Then the data in the address is verified.

If the programmed data is incorrect, another 0.1 ms pulse is applied to $\overline{\text{PGM}}$ pin.

This programming procedure is repeated until correct data is read from the address. (25 times maximum)

Subsequently, all data are programmed in all addresses.

The verification for all data is done under the condition of $V_{PP} = V_{CC} = 5\text{ V}$ after all data were written.

Figure 3.2.2 shows the programming flowchart.

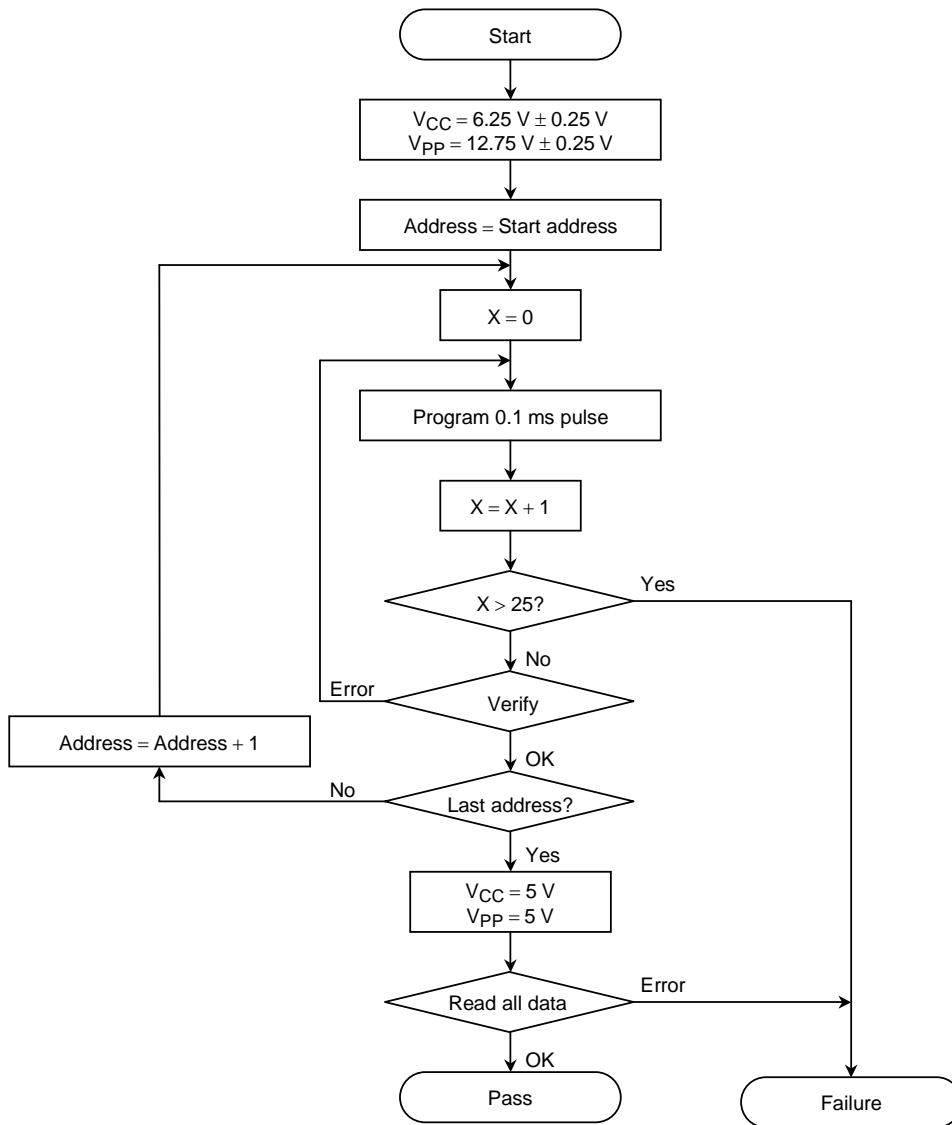

Figure 3.2.2 Flowchart (High-speed program writing)

(8) Security bit

The TMP93PS44 has a security bit in PROM cell.

If the security bit is programmed to “0”, the content of the PROM is disable to be read (FFH data) in PROM mode.

(How to program the security bit.)

The difference from the programming procedures described in section 3.2 (1) “Mode setting and function” are as follows.

1. Setting OTP adaptor

Set the switch (SW1) to S side.

2. Setting PROM programmer

i) Transferring the data

ii) Setting of programming address

The security bit is in bit0 of address 00000H.

Set the start address 00000H and the end address 00000H.

Set the data FEH at the address 00000H.

4. Electrical Characteristics

4.1 Maximum Ratings (TMP93PS44)

"X" used in an expression shows a cycle of clock f_{FPH} selected by SYSCR1<SYSCK>. If a clock gear or a low speed oscillator is selected, a value of "X" is different. The value as an example is calculated at f_c , gear = 1/ f_c (SYSCR1<SYSCK, GEAR2:0> = "0000").

Parameter	Symbol	Rating	Unit
Power supply voltage	V_{CC}	-0.5 to 6.5	V
Input voltage	V_{IN}	except \overline{EA} pin -0.5 to $V_{CC} + 0.5$ \overline{EA} pin -0.5 to 14.0	
Output current (Per 1 pin) P7	I_{OL1}	20	mA
Output current (Per 1 pin) except P7	I_{OL2}	2	
Output current (P7 total)	ΣI_{OL1}	80	
Output current (Total)	ΣI_{OL}	120	
Output current (Total)	ΣI_{OH}	-80	
Power dissipation ($T_a = 85^\circ\text{C}$)	P_D	350	mW
Soldering temperature (10 s)	T_{SOLDER}	260	$^\circ\text{C}$
Storage temperature	T_{STG}	-65 to 150	
Operating temperature	T_{OPR}	-40 to 85	

Note: The maximum ratings are rated values which must not be exceeded during operation, even for an instant. Any one of the ratings must not be exceeded. If any maximum rating is exceeded, a device may break down or its performance may be degraded, causing it to catch fire or explode resulting in injury to the user. Thus, when designing products which include this device, ensure that no maximum rating value will ever be exceeded.

4.2 DC Characteristics (1/2)

$T_a = -40$ to 85°C

Parameter		Symbol	Condition	Min	Typ. (Note)	Max	Unit
Power supply voltage ($AV_{CC} = V_{CC}$ $AV_{SS} = V_{SS} = 0\text{V}$)		V_{CC}	$f_c = 4$ to 20 MHz $f_s = 30$ to 34 kHz	4.5		5.5	V
Input low voltage	AD0 to AD15	V_{IL}	$V_{CC} \geq 4.5\text{V}$ $V_{CC} < 4.5\text{V}$	-0.3		0.8	
	Port 2 to 7 (except P35)	V_{IL1}	$V_{CC} = 2.7$ to 5.5V		0.3 V_{CC}		
	\overline{RESET} , \overline{NMI} , $\overline{INT0}$	V_{IL2}			0.25 V_{CC}		
	\overline{EA} , $\overline{AM8}/\overline{AM16}$	V_{IL3}			0.3		
	X1	V_{IL4}			0.2 V_{CC}		
Input high voltage	AD0 to AD15	V_{IH}	$V_{CC} \geq 4.5\text{V}$ $V_{CC} < 4.5\text{V}$	2.2 2.0		$V_{CC} + 0.3$	
	Port 2 to 7 (except P35)	V_{IH1}	$V_{CC} = 2.7$ to 5.5V	0.7 V_{CC}			
	\overline{RESET} , \overline{NMI} , $\overline{INT0}$	V_{IH2}		0.75 V_{CC}			
	\overline{EA} , $\overline{AM8}/\overline{AM16}$	V_{IH3}		$V_{CC} - 0.3$			
	X1	V_{IH4}		0.8 V_{CC}			
Output low voltage	V_{OL}	$I_{OL} = 1.6\text{mA}$ ($V_{CC} = 2.7$ to 5.5V)			0.45		
Output low current (P7)	I_{OL7}	$V_{OL} = 1.0\text{V}$	($V_{CC} = 5\text{V} \pm 10\%$) ($V_{CC} = 3\text{V} \pm 10\%$)	16 7		mA	
Output high voltage	V_{OH1}	$I_{OH} = -400\ \mu\text{A}$ ($V_{CC} = 3\text{V} \pm 10\%$)		2.4		V	
	V_{OH2}	$I_{OH} = -400\ \mu\text{A}$ ($V_{CC} = 5\text{V} \pm 10\%$)		4.2			

Note: Typical values are for $T_a = 25^\circ\text{C}$ and $V_{CC} = 5\text{V}$ unless otherwise noted.

DC Characteristics (2/2)

Parameter	Symbol	Condition	Min	Typ.(Note 1)	Max	Unit	
Darlington drive current (8 output pins max)	I_{DAR} (Note 2)	$V_{EXT} = 1.5\text{ V}$ $R_{EXT} = 1.1\text{ k}\Omega$ ($V_{CC} = 5\text{ V} \pm 10\%$ only)	-1.0		-3.5	mA	
Input leakage current	I_{LI}	$0.0 \leq V_{IN} \leq V_{CC}$		0.02	± 5	μA	
Output leakage current	I_{LO}	$0.2 \leq V_{IN} \leq V_{CC} - 0.2$		0.05	± 10	μA	
Power down voltage (at STOP, RAM backup)	V_{STOP}	$V_{IL2} = 0.2V_{CC}$, $V_{IH2} = 0.8V_{CC}$	2.0		6.0	V	
$\overline{\text{RESET}}$ pull-up resistance	R_{RST}	$V_{CC} = 5.5\text{ V}$	45		130	k Ω	
		$V_{CC} = 4.5\text{ V}$	50		160		
		$V_{CC} = 3.3\text{ V}$	70		280		
		$V_{CC} = 2.7\text{ V}$	90		400		
Pin capacitance	C_{IO}	$f_c = 1\text{ MHz}$			10	pF	
Schmitt width RESET, NMI, INTO	V_{TH}		0.4	1.0		V	
Programmable pull-up resistance	R_{KH}	$V_{CC} = 5.5\text{ V}$	45		130	k Ω	
		$V_{CC} = 4.5\text{ V}$	50		160		
		$V_{CC} = 3.3\text{ V}$	70		280		
		$V_{CC} = 2.7\text{ V}$	90		400		
NORMAL (Note 3)	I_{CC}	$V_{CC} = 5\text{ V} \pm 10\%$ $f_c = 20\text{ MHz}$		19	25	mA	
RUN				17	25		
IDLE2				12	17		
IDLE1				3.5	5		
NORMAL (Note 3)				6.5	10		
RUN				5.0	9		
IDLE2		$V_{CC} = 3\text{ V} \pm 10\%$ $f_c = 12.5\text{ MHz}$ (Typ.: $V_{CC} = 3.0\text{ V}$)		4.5	6.5		
IDLE1				0.8	1.5		
SLOW (Note 3)			$V_{CC} = 3\text{ V} \pm 10\%$ $f_s = 32.768\text{ kHz}$ (Typ.: $V_{CC} = 3.0\text{ V}$)		20	35	μA
RUN					16	30	
IDLE2					15	25	
IDLE1					5	15	
STOP		$T_a \leq 50^\circ\text{C}$	$V_{CC} = 2.7\text{ V}$ to 5.5 V		10	μA	
		$T_a \leq 70^\circ\text{C}$			20		
		$T_a \leq 85^\circ\text{C}$			50		

Note 1: Typical values are for $T_a = 25^\circ\text{C}$ and $V_{CC} = 5\text{ V}$ unless otherwise noted.

Note 2: I_{DAR} is guaranteed for total of up to 8 ports.

Note 3: I_{CC} measurement conditions (NORMAL, SLOW):

Only CPU is operational; output pins are open and input pins are fixed.

(Reference) Definition of I_{DAR}

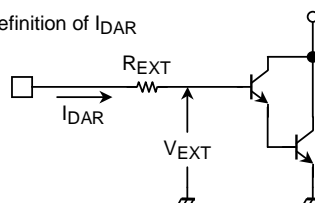

4.3 AC Electrical Characteristics

(1) $V_{CC} = 5\text{ V} \pm 10\%$

No.	Parameter	Symbol	Variable		16 MHz		20 MHz		Unit
			Min	Max	Min	Max	Min	Max	
1	Osc. period (= X)	t _{OSC}	50	31250	62.5		50		ns
2	CLK pulse width	t _{CLK}	2X – 40		85		60		ns
3	A0 to A23 valid → CLK hold	t _{AK}	0.5X – 20		11		5		ns
4	CLK valid → A0 to A23 hold	t _{KA}	1.5X – 70		24		5		ns
5	A0 to A15 valid → ALE fall	t _{AL}	0.5X – 15		16		10		ns
6	ALE fall → A0 to A15 hold	t _{LA}	0.5X – 20		11		5		ns
7	ALE high pulse width	t _{LL}	X – 40		23		10		ns
8	ALE fall → $\overline{\text{RD}}$ / $\overline{\text{WR}}$ fall	t _{LC}	0.5X – 25		6		0		ns
9	$\overline{\text{RD}}$ / $\overline{\text{WR}}$ rise → ALE rise	t _{CL}	0.5X – 20		11		5		ns
10	A0 to A15 valid → $\overline{\text{RD}}$ / $\overline{\text{WR}}$ fall	t _{ACL}	X – 25		38		25		ns
11	A0 to A23 valid → $\overline{\text{RD}}$ / $\overline{\text{WR}}$ fall	t _{ACH}	1.5X – 50		44		25		ns
12	$\overline{\text{RD}}$ / $\overline{\text{WR}}$ rise → A0 to A23 hold	t _{CA}	0.5X – 25		6		0		ns
13	A0 to A15 valid → D0 to D15 input	t _{ADL}		3.0X – 55		133		95	ns
14	A0 to A23 valid → D0 to D15 input	t _{ADH}		3.5X – 65		154		110	ns
15	$\overline{\text{RD}}$ fall → D0 to D15 input	t _{RD}		2.0X – 60		65		40	ns
16	$\overline{\text{RD}}$ low pulse width	t _{RR}	2.0X – 40		85		60		ns
17	$\overline{\text{RD}}$ rise → D0 to D15 hold	t _{HR}	0		0		0		ns
18	$\overline{\text{RD}}$ rise → A0 to A15 output	t _{RAE}	X – 15		48		35		ns
19	$\overline{\text{WR}}$ low pulse width	t _{WW}	2.0X – 40		85		60		ns
20	D0 to D15 valid → $\overline{\text{WR}}$ rise	t _{DW}	2.0X – 55		70		45		ns
21	$\overline{\text{WR}}$ rise → D0 to D15 hold	t _{WD}	0.5X – 15		16		10		ns
22	A0 to A23 valid → $\overline{\text{WAIT}}$ input	t _{AWH}		3.5X – 90		129		85	ns
23	A0 to A15 valid → $\overline{\text{WAIT}}$ input	t _{AWL}		3.0X – 80		108		70	ns
24	$\overline{\text{RD}}$ / $\overline{\text{WR}}$ fall → $\overline{\text{WAIT}}$ hold	t _{CW}	2.0X + 0		125		100		ns
25	A0 to A23 valid → Port input	t _{APH}		2.5X – 120		36		5	ns
26	A0 to A23 valid → Port hold	t _{APH2}	2.5X + 50		206		175		ns
27	$\overline{\text{WR}}$ rise → Port valid	t _{CP}		200		200		200	ns

AC measuring conditions

- Output level: High 2.2 V/Low 0.8 V, CL = 50 pF
(However CL = 100 pF for AD0 to AD15, A0 to A23, ALE, $\overline{\text{RD}}$, $\overline{\text{WR}}$, $\overline{\text{HWR}}$, CLK)
- Input level: High 2.4 V/Low 0.45 V (AD0 to AD15)
High $0.8 \times V_{CC}$ /Low $0.2 \times V_{CC}$ (except for AD0 to AD15)

(2) $V_{CC} = 3 V \pm 10\%$

No.	Parameter	Symbol	Variable		12.5 MHz		Unit
			Min	Max	Min	Max	
1	Osc. period (= X)	t_{OSC}	80	31250	80		ns
2	CLK pulse width	t_{CLK}	2X - 40		120		ns
3	A0 to A23 valid → CLK hold	t_{AK}	0.5X - 30		10		ns
4	CLK valid → A0 to A23 hold	t_{KA}	1.5X - 80		40		ns
5	A0 to A15 valid → ALE fall	t_{AL}	0.5X - 35		5		ns
6	ALE fall → A0 to A15 hold	t_{LA}	0.5X - 35		5		ns
7	ALE high pulse width	t_{LL}	X - 60		20		ns
8	ALE fall → \overline{RD} / \overline{WR} fall	t_{LC}	0.5X - 35		5		ns
9	\overline{RD} / \overline{WR} rise → ALE rise	t_{CL}	0.5X - 40		0		ns
10	A0 to A15 valid → \overline{RD} / \overline{WR} fall	t_{ACL}	X - 50		30		ns
11	A0 to A23 valid → \overline{RD} / \overline{WR} fall	t_{ACH}	1.5X - 50		70		ns
12	\overline{RD} / \overline{WR} rise → A0 to A23 hold	t_{CA}	0.5X - 40		0		ns
13	A0 to A15 valid → D0 to D15 input	t_{ADL}		3.0X - 110		130	ns
14	A0 to A23 valid → D0 to D15 input	t_{ADH}		3.5X - 125		155	ns
15	\overline{RD} fall → D0 to D15 input	t_{RD}		2.0X - 115		45	ns
16	\overline{RD} low pulse width	t_{RR}	2.0X - 40		120		ns
17	\overline{RD} rise → D0 to D15 hold	t_{HR}	0		0		ns
18	\overline{RD} rise → A0 to A15 output	t_{RAE}	X - 25		55		ns
19	\overline{WR} low pulse width	t_{WW}	2.0X - 40		120		ns
20	D0 to D15 valid → \overline{WR} rise	t_{DW}	2.0X - 120		40		ns
21	\overline{WR} rise → D0 to D15 hold	t_{WD}	0.5X - 40		0		ns
22	A0 to A23 valid → \overline{WAIT} input	t_{AWH}		3.5X - 130		150	ns
23	A0 to A15 valid → \overline{WAIT} input	t_{AWL}		3.0X - 100		140	ns
24	\overline{RD} / \overline{WR} fall → \overline{WAIT} hold	t_{CW}	2.0X + 0		160		ns
25	A0 to A23 valid → Port input	t_{APH}		2.5X - 195		5	ns
26	A0 to A23 valid → Port hold	t_{APH2}	2.5X + 50		250		ns
27	\overline{WR} rise → Port valid	t_{CP}		200		200	ns

AC measuring conditions

- Output level: High $0.7 \times V_{CC}$ / Low $0.3 \times V_{CC}$, $CL = 50$ pF
- Input level: High $0.9 \times V_{CC}$ / Low $0.1 \times V_{CC}$

(3) Read cycle

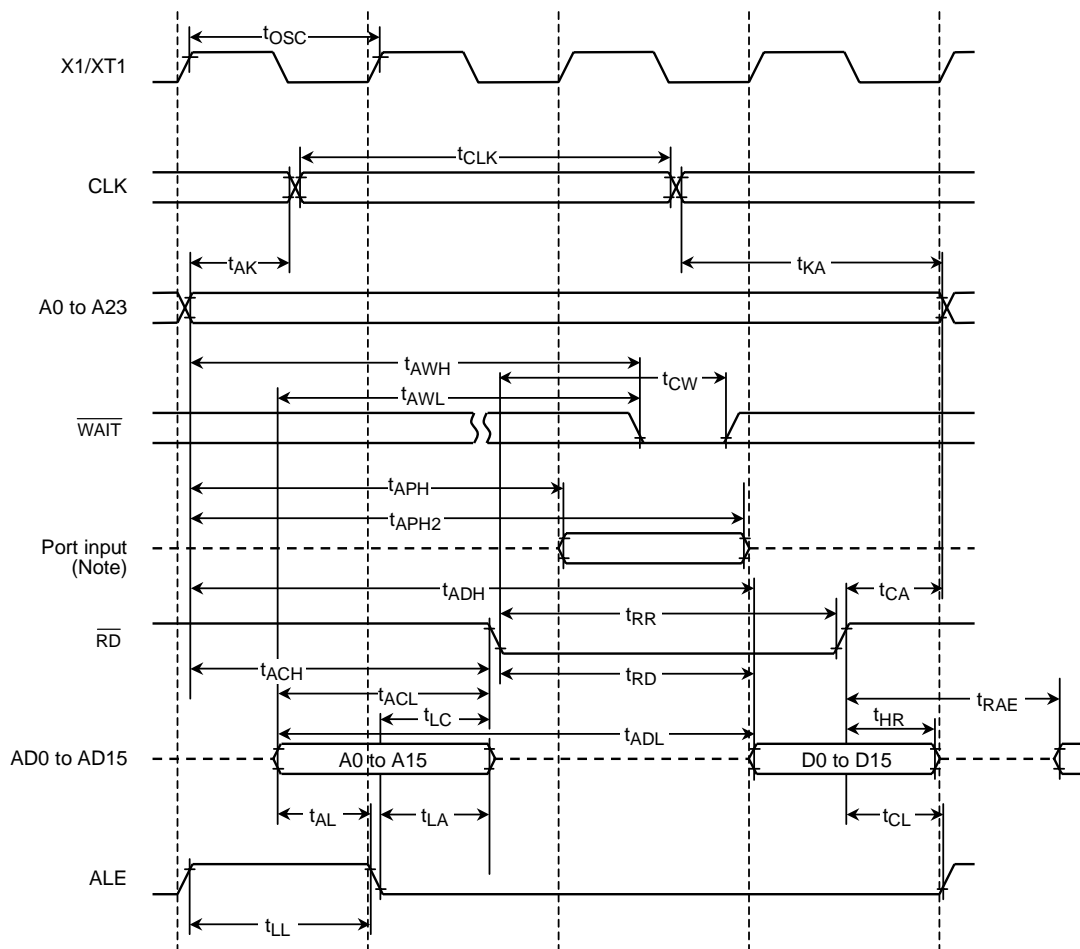

Note: Since the CPU accesses the internal area to read data from a port, the control signals of external pins such as \overline{RD} and \overline{CS} are not enabled. Therefore, the above waveform diagram should be regarded as depicting internal operation. Please also note that the timing and AC characteristics of port input/output shown above are typical representation. For details, contact your local Toshiba sales representative.

(4) Write cycle

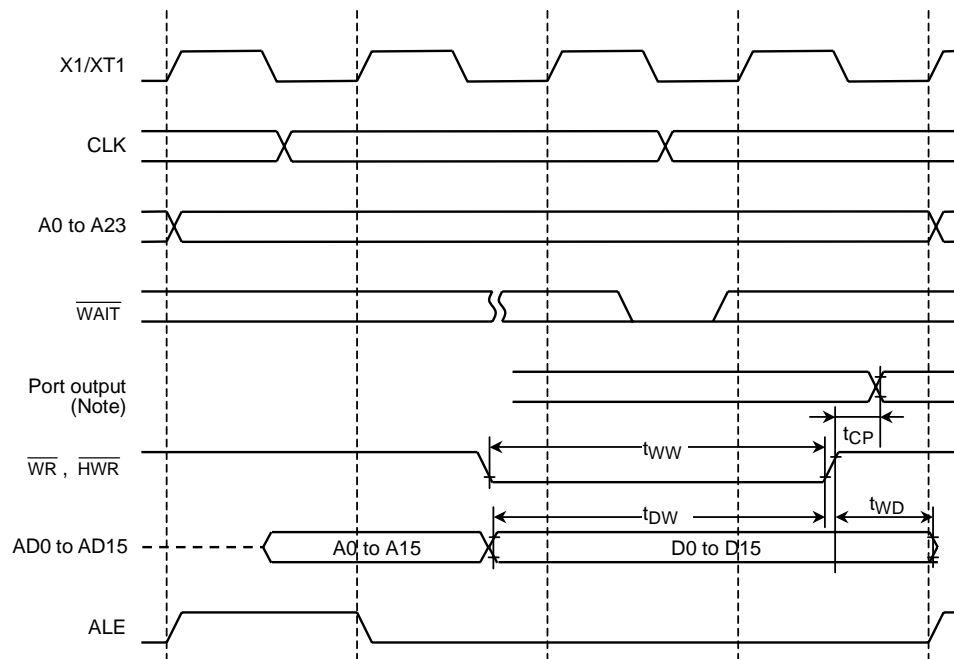

Note: Since the CPU accesses the internal area to write data to a port, the control signals of external pins such as \overline{WR} and \overline{CS} are not enabled. Therefore, the above waveform diagram should be regarded as depicting internal operation. Please also note that the timing and AC characteristics of port input/output shown above are typical representation. For details, contact your local Toshiba sales representative.

4.4 Serial Channel Timing

(1) I/O interface mode

1. SCLK input mode

Parameter	Symbol	Variable		32.768 MHz (Note)		12.5 MHz		20 MHz		Unit
		Min	Max	Min	Max	Min	Max	Min	Max	
SCLK cycle	t _{SCY}	16X		488 μs		1.28 μs		0.8 μs		ns
Output data → Falling edge of SCLK	t _{OSS}	t _{SCY} /2 - 5X - 50		91.5 μs		190		100		ns
SCLK rising/falling edge → Output data hold	t _{OHS}	5X - 100		152 μs		300		150		ns
SCLK rising/falling edge → Input data hold	t _{HSR}	0		0		0		0		ns
SCLK rising/falling edge → Effective data input	t _{SRD}		t _{SCY} - 5X - 100		336 μs		780		450	ns

Note 1: When fs is used as system clock or fs divided by 4 is used as input clock to prescaler.

Note 2: SCLK rising/falling timing; SCLK rising in the rising mode of SCLK, SCLK falling in the falling mode of SCLK.

2. SCLK output mode

Parameter	Symbol	Variable		32.768 MHz (Note)		12.5 MHz		20 MHz		Unit
		Min	Max	Min	Max	Min	Max	Min	Max	
SCLK cycle (Programmable)	t _{SCY}	16X	8192X	488 μs	250 ms	1.28 μs	655.36 μs	0.8 μs	409.6 μs	ns
Output data → SCLK rising edge	t _{OSS}	t _{SCY} - 2X - 150		427 μs		970		550		ns
SCLK rising edge → Output data hold	t _{OHS}	2X - 80		60 μs		80		20		ns
SCLK rising edge → Input data hold	t _{HSR}	0		0		0		0		ns
SCLK rising edge → Effective data input	t _{SRD}		t _{SCY} - 2X - 150		428 μs		970		550	ns

Note: When fs is used as system clock or fs divided by 4 is used as input clock to prescaler.

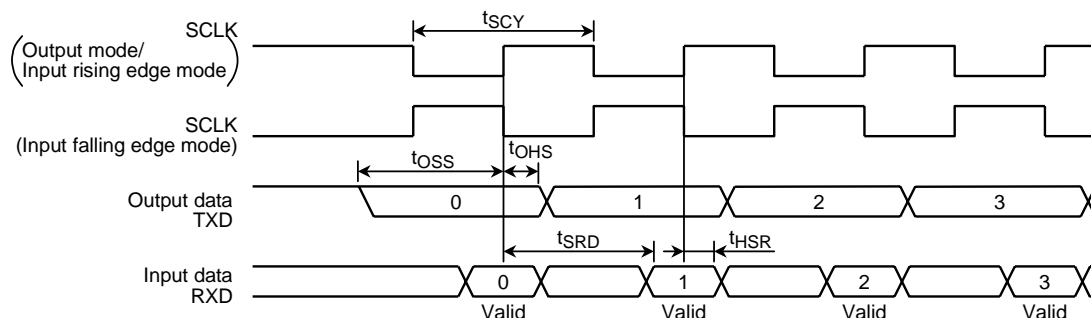

(2) UART mode (SCLK0 and SCLK1 are external input)

Parameter	Symbol	Variable		32.768 MHz (Note)		12.5 MHz		20 MHz		Unit
		Min	Max	Min	Max	Min	Max	Min	Max	
SCLK cycle	t _{SCY}	4X + 20		122 μs		340		220		ns
SCLK Low level pulse width	t _{SCYL}	2X + 5		6 μs		165		105		ns
SCLK High level pulse width	t _{SCYH}	2X + 5		6 μs		165		105		ns

Note: When fs is used as system clock or fs divided by 4 is used as input clock to prescaler.

4.5 AD Conversion Characteristics

$$AV_{CC} = V_{CC}, AV_{SS} = V_{SS}$$

Parameter	Symbol	Power Supply	Min	Typ.	Max	Unit
Analog reference voltage (+)	V _{REFH}	V _{CC} = 5 V ± 10%	V _{CC} - 0.2 V	V _{CC}	V _{CC}	V
		V _{CC} = 3 V ± 10%	V _{CC} - 0.2 V	V _{CC}	V _{CC}	
Analog reference voltage (-)	V _{REFL}	V _{CC} = 5 V ± 10%	V _{SS}	V _{SS}	V _{SS} + 0.2 V	
		V _{CC} = 3 V ± 10%	V _{SS}	V _{SS}	V _{SS} + 0.2 V	
Analog input voltage range	V _{AIN}		V _{REFL}		V _{REFH}	
Analog current for analog reference voltage <V _{REFON} > = 1	I _{REF} (V _{REFL} = 0 V)	V _{CC} = 5 V ± 10%		0.5	1.5	mA
		V _{CC} = 3 V ± 10%		0.3	0.9	
<V _{REFON} > = 0		V _{CC} = 2.7 to 5.5 V		0.02	5.0	μA
Error (except quantization errors)	-	V _{CC} = 5 V ± 10%		±1.0	±3.0	LSB
		V _{CC} = 3 V ± 10%		±1.0	±5.0	

Note 1: 1LSB = (V_{REFH} - V_{REFL})/2¹⁰ [V]

Note 2: The operation above is guaranteed for f_{FPH} ≥ 4 MHz.

Note 3: The value I_{CC} includes the current which flows through the AV_{CC} pin.

4.6 Event Counter Input Clock (external input clock: TI0, TI4, TI5, TI6, TI7)

Parameter	Symbol	Variable		12.5 MHz		20 MHz		Unit
		Min	Max	Min	Max	Min	Max	
Clock cycle	t _{VCK}	8X + 100		740		500		ns
Low level clock pulse width	t _{VCKL}	4X + 40		360		240		ns
High level clock pulse width	t _{VCKH}	4X + 40		360		240		ns

4.7 Interrupt and Capture Operation

(1) \overline{NMI} , INT0 interrupts

Parameter	Symbol	Variable		12.5 MHz		20 MHz		Unit
		Min	Max	Min	Max	Min	Max	
\overline{NMI} , INT0 low level pulse width	t _{INTAL}	4X		320		200		ns
\overline{NMI} , INT0 high level pulse width	t _{INTAH}	4X		320		200		ns

(2) INT1, INT4 to INT7 interrupts and capture

Parameter	Symbol	Variable		12.5 MHz		20 MHz		Unit
		Min	Max	Min	Max	Min	Max	
INT1, INT4 to INT7 low level pulse width	t _{INTBL}	4X + 100		420		300		ns
INT1, INT4 to INT7 high level pulse width	t _{INTBH}	4X + 100		420		300		ns

4.8 Serial Bus Interface Timing

(1) I²C bus mode

Parameter	Symbol	Variable			Unit
		Min	Typ.	Max	
START command → SDA fall	t _{GSTA}	3X			ns
Hold time START condition	t _{HD:STA}	2 ⁿ X			ns
SCL low level pulse width	t _{LOW}	2 ⁿ X			ns
SCL high level pulse width	t _{HIGH}	2 ⁿ X + 12X			ns
Data hold time (Input)	t _{HD:IDAT}	0			ns
Data setup time (Input)	t _{SU:IDAT}	250			ns
Data hold time (Output)	t _{HD:ODAT}	7X		11X	ns
Data output → SCL rising edge	t _{ODAT}		2 ⁿ X - t _{HD:ODAT}		ns
STOP command → SDA fall	t _{FSDA}	3X			ns
SDA falling edge → SCL rising edge	t _{FDRC}	2 ⁿ X			ns
Setup time STOP condition	t _{SU:STO}	2 ⁿ X + 16X			ns

Note: "n" value is set by SBICR1<SCK2:0>

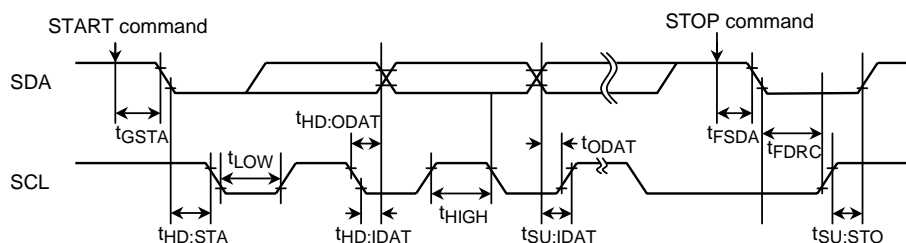

(2) Clocked-synchronous 8-bit SIO mode

1. SCK input mode

Parameter	Symbol	Variable		Unit
		Min	Max	
SCK cycle	t_{SCY2}	2^5X		ns
SCK falling edge → Output data hold	t_{OHS2}	$6X$		ns
Output data → SCK rising edge	t_{OSS2}	$t_{SCY2} - 6X$		ns
SCK rising edge → Input data hold	t_{HSR2}	$6X$		ns
Input data → SCK rising edge	t_{ISS2}	0		ns

2. SCK output mode

Parameter	Symbol	Variable		Unit
		Min	Max	
SCK cycle	t_{SCY2}	2^5X	$2^{11}X$	ns
SCK falling edge → Output data hold	t_{OHS2}	$2X$		ns
Output data → SCK rising edge	t_{OSS2}	$t_{SCY2} - 2X$		ns
SCK rising edge → Input data hold	t_{HSR2}	$2X$		ns
Input data → SCK rising edge	t_{ISS2}	0		ns

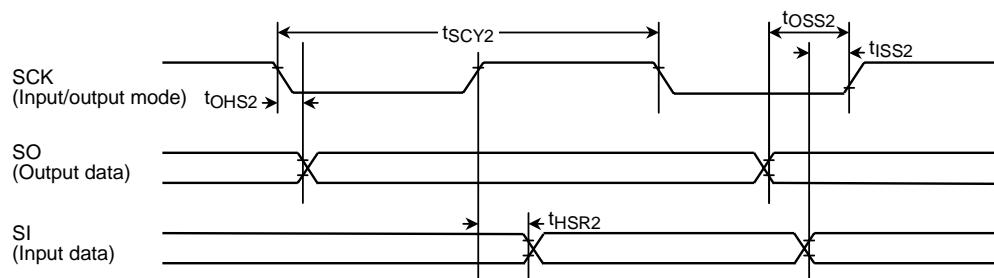

4.9 Read Operation in PROM Mode

DC/AC characteristics

$T_a = 25 \pm 5^\circ\text{C}$ $V_{CC} = 5\text{ V} \pm 10\%$

Parameter	Symbol	Condition	Min	Max	Unit
V_{PP} read voltage	V_{PP}	–	4.5	5.5	V
Input high voltage (A0 to A16, \overline{CE} , \overline{OE} , PGM)	V_{IH1}	–	2.2	$V_{CC} + 0.3$	
Input low voltage (A0 to A16, \overline{CE} , \overline{OE} , PGM)	V_{IL1}	–	-0.3	0.8	
Address to output delay	t_{ACC}	$C_L = 50\text{ pF}$	–	$2.25T_{CYC} + \alpha$	ns

$T_{CYC} = 400\text{ ns}$ (10 MHz Clock)

$\alpha = 200\text{ ns}$

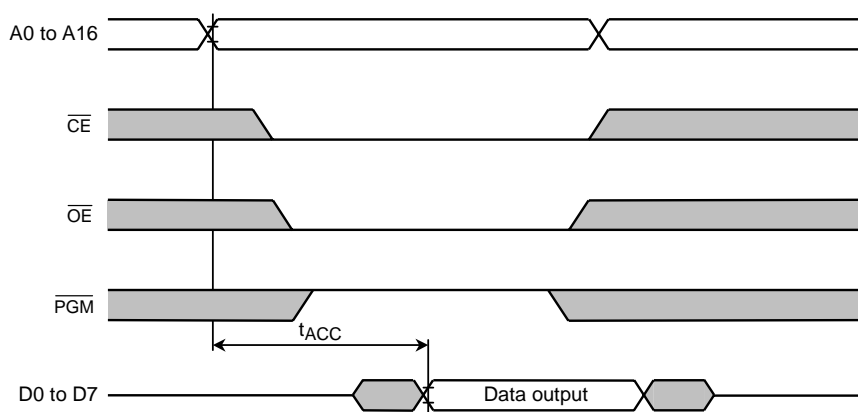

4.10 Program Operation in PROM Mode

DC/AC characteristics

 $T_a = 25 \pm 5^\circ\text{C}$ $V_{CC} = 6.25 \text{ V} \pm 0.25 \text{ V}$

Parameter	Symbol	Condition	Min	Typ.	Max	Unit
Programming supply voltage	V_{PP}	–	12.50	12.75	13.00	V
Input high voltage (D0 to D7, A0 to A16, \overline{CE} , \overline{OE} , \overline{PGM})	V_{IH}	–	2.6		$V_{CC} + 0.3$	
Input low voltage (D0 to D7, A0 to A16, \overline{CE} , \overline{OE} , \overline{PGM})	V_{IL}	–	–0.3		0.8	
V_{CC} supply current	I_{CC}	$f_c = 10 \text{ MHz}$	–		50	mA
V_{PP} supply current	I_{PP}	$V_{PP} = 13.00 \text{ V}$	–		50	
\overline{PGM} program pulse width	t_{PW}	$C_L = 50 \text{ pF}$	0.095	0.1	0.105	ms

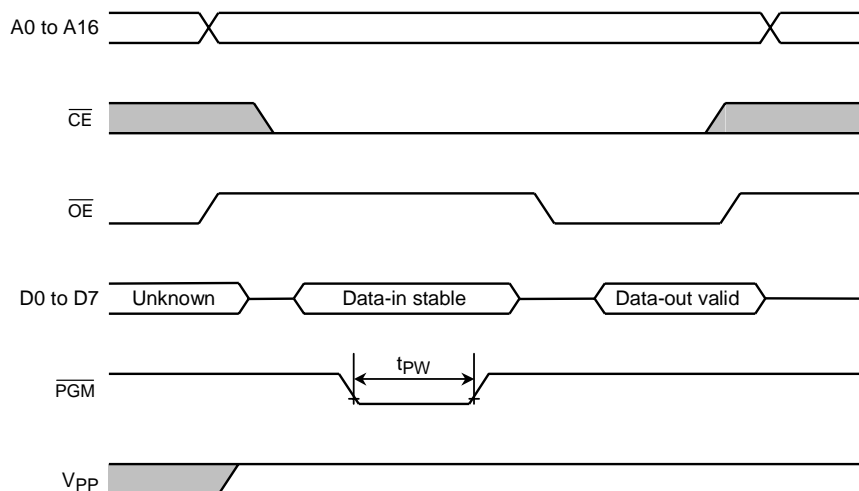

Note 1: The power supply of V_{PP} (12.75 V) must be set power-on at the same time or the later time for a power supply of V_{CC} and must be clear power-on at the same time or early time for a power supply of V_{CC} .

Note 2: The pulling up/down device on condition of $V_{PP} = 12.75 \text{ V}$ suffers a damage for the device.

Note 3: The maximum spec of V_{PP} pin is 14.0 V. Be carefull a overshoot at the programming.

5. Package Dimensions

P-LQFP80-1212-0.50E

Unit: mm

