



**Sil 1151**  
**PanelLink Receiver**

**Data Sheet**

Document # Sil-DS-0023-C

## Silicon Image, Inc.

SiI-DS-0023-C  
June 2005

### Application Information

To obtain the most updated Application Notes and other useful information for your design, please visit the Silicon Image web site at [www.siimage.com](http://www.siimage.com), or contact your local Silicon Image sales office.

### Copyright Notice

This manual is copyrighted by Silicon Image, Inc. Do not reproduce, transform to any other format, or send/transmit any part of this documentation without the expressed written permission of Silicon Image, Inc.

### Trademark Acknowledgment

Silicon Image, the Silicon Image logo, PanelLink<sup>®</sup> and the PanelLink<sup>®</sup> Digital logo are registered trademarks of Silicon Image, Inc. TMDS<sup>™</sup> is a trademark of Silicon Image, Inc. VESA<sup>®</sup> is a registered trademark of the Video Electronics Standards Association. All other trademarks are the property of their respective holders.

### Disclaimer

This document provides technical information for the user. Silicon Image, Inc. reserves the right to modify the information in this document as necessary. The customer should make sure that they have the most recent data sheet version. Silicon Image, Inc. holds no responsibility for any errors that may appear in this document. Customers should take appropriate action to ensure their use of the products does not infringe upon any patents. Silicon Image, Inc. respects valid patent rights of third parties and does not infringe upon or assist others to infringe upon such rights.

**All information contained herein is subject to change without notice.**

### Revision History

Revision	Date	Comment
SiI-DS-0023-A	10/2003	Data Sheet
SiI-DS-0023-B	1/2004	Part Marking Spec Updated
SiI-DS-0023-C	6/2005	Figure 3, 15, 17, 19, 21, 22, 24, 30 add/update; I <sup>2</sup> C Reset recommendations, T <sub>RESET</sub> timing added;

© 2001, 2002, 2003, 2004, 2005 Silicon Image, Inc.

## TABLE OF CONTENTS

<b>Sil 1151 Pin Diagram</b> .....	<b>1</b>
<b>Functional Description</b> .....	<b>2</b>
<b>Electrical Specifications</b> .....	<b>3</b>
Absolute Maximum Conditions .....	3
Normal Operating Conditions .....	3
Digital I/O Specifications .....	3
General DC Specifications .....	4
General AC Specifications .....	5
<b>Compatibility Mode Selection Specifications</b> .....	<b>6</b>
Sil 151B (Compatible) Mode DC Specifications .....	6
Sil 151B (Compatible) Mode AC Specifications .....	8
Sil 1151 (Programmable) Mode DC Specifications .....	9
Sil 1151 (Programmable) Mode AC Specifications .....	11
<b>Timing Diagrams</b> .....	<b>15</b>
<b>Pin Descriptions</b> .....	<b>19</b>
Output Pins .....	19
Differential Signal Data Pins .....	19
Configuration Pins.....	20
Power Management Pins.....	20
Power and Ground Pins.....	21
<b>Feature Information</b> .....	<b>22</b>
HSYNC De-jitter Function .....	22
Clock Detect Function.....	22
OCK_INV Function .....	22
I <sup>2</sup> C Slave Interface .....	23
TFT Panel Data Mapping.....	24
<b>Design Recommendations</b> .....	<b>31</b>
Differences Between Sil 151B and Sil 1151 .....	31
Using Sil 1151 in Multiple-Input Applications .....	32
Using Sil 1151 to Replace TI TFP401 .....	32
Adjusting Equalizer and Bandwidth .....	33
Voltage Ripple Regulation.....	34
Decoupling Capacitors.....	35
Series Damping Resistors on Outputs.....	36
Receiver Layout .....	37
PCB Ground Planes.....	38
Staggered Outputs and Two Pixels per Clock .....	38
Adjusting Output Timings for Loading.....	38
<b>Packaging</b> .....	<b>39</b>
Dimensions and Marking .....	39
<b>Ordering Information</b> .....	<b>39</b>

## LIST OF TABLES

Table 1. DC Parametric Specifications .....	4
Table 2. General AC Specifications .....	5
Table 3. SiI 151B Mode DC Specifications .....	7
Table 4. SiI 151B Mode AC Specifications .....	8
Table 5. SiI 1151 Mode DC Specifications.....	10
Table 6. SiI 1151 Mode AC Specifications .....	11
Table 7. Sample Calculation of Data Output Setup and Hold Times – OCK_INV=0.....	13
Table 8. Sample Calculation of Data Output Setup and Hold Times – OCK_INV=1.....	14
Table 9. One Pixel per Clock Mode Data Mapping.....	24
Table 10. Two Pixel per Clock Mode Data Mapping.....	24
Table 11. One Pixel per Clock Input/Output TFT Mode – VESA P&D and FPD1-2™ Compliant.....	25
Table 12. Two Pixels per Clock Input/Output TFT Mode.....	26
Table 13. 24-bit One Pixel per Clock Input with 24-bit Two Pixels per Clock Output TFT Mode .....	27
Table 14. 18-bit One Pixel per Clock Input with 18-bit Two Pixels per Clock Output TFT Mode .....	28
Table 15. Two Pixels per Clock Input with One Pixel per Clock Output TFT Mode .....	29
Table 16. Output Clock Configuration by Typical TFT Panel Application .....	30
Table 17. New Pin Functions for SiI 1151 in Programmable Mode.....	31
Table 18. Internal I <sup>2</sup> C Registers.....	33
Table 19: I <sup>2</sup> C Register Field Definitions.....	34
Table 20. Recommended Components for 1-2MHz Noise Suppression.....	36
Table 21. Recommended Components for 100-200kHz Noise Suppression on PVCC .....	36

## LIST OF FIGURES

Figure 1. Functional Block Diagram .....	2
Figure 2. SiI 151B Mode Control of Output Pin Drive Strength .....	6
Figure 3. Output Loading in SiI 151B Mode .....	9
Figure 4. SiI 1151 Mode Control of Output Pin Drive Strength.....	9
Figure 5. Receiver Output Setup and Hold Times – OCK_INV=0.....	12
Figure 6. Receiver Output Setup and Hold Times – OCK_INV=1.....	13
Figure 7. Digital Output Transition Times .....	15
Figure 8. Receiver Clock Cycle/High/Low Times .....	15
Figure 9. Channel-to-Channel Skew Timing .....	15
Figure 10. Receiver Clock-to-Output Delay and Duty Cycle Limits .....	16
Figure 11. Output Signals Disabled Timing from Clock Inactive .....	16
Figure 12. Wake-Up on Clock Detect .....	16
Figure 13. Output Signals Disabled Timing from PD# Active .....	17
Figure 14. SCDDT Timing from DE Inactive or Active .....	17
Figure 15. Two Pixels per Clock Staggered Output Timing Diagram .....	17
Figure 16. I <sup>2</sup> C Data Valid Delay (driving Read Cycle data).....	18
Figure 17. I <sup>2</sup> C Reset Timing at Power-Up or Prior to first I <sup>2</sup> C Access.....	18
Figure 18. Block Diagram for OCK_INV.....	22
Figure 19. I <sup>2</sup> C Byte Read.....	23
Figure 20. I <sup>2</sup> C Byte Write .....	23
Figure 21. RESET Generation Delay .....	31
Figure 22. Recommended RESET Circuit.....	32
Figure 23. Voltage Regulation using TL431 .....	34
Figure 24. Voltage Regulation using LM317 .....	35
Figure 25. Decoupling and Bypass Capacitor Placement.....	35
Figure 26. Decoupling and Bypass Schematic.....	36
Figure 27. Receiver Output Series Damping Resistors .....	36
Figure 28. General Signal Routing Recommendations.....	37
Figure 29. Signal Trace Routing Example.....	37
Figure 30. Package Diagram.....	39

### General Description

The Sil 1151 receiver uses PanelLink Digital technology to support high-resolution displays up to SXGA (25-112MHz). This receiver supports up to true color panels (24 bits per pixel, 16M colors) with both one and two pixels per clock.

All PanelLink products are designed on a scaleable CMOS architecture, ensuring support for future performance enhancements while maintaining the same logical interface. System designers can be assured that the interface will be stable through a number of technology and performance generations.

PanelLink Digital technology simplifies PC and display interface design by resolving many of the system level issues associated with high-speed mixed signal design, providing the system designer with a digital interface solution that is quicker to market and lower in cost.

### Features

- Supports 10 meter cables at SXGA speed
- I<sup>2</sup>C port for dynamic optimization of settings to compensate for long cables and/or poor quality transmitters
- Flexible output drive controls to optimize timings for all possible configurations
- 3.3V operation
- Time staggered data output for reduced ground bounce and lower EMI
- Sync Detect feature for DVI “Hot Plugging”
- ESD tolerant to 5kV (HBM) on all pins
- Compliant with DVI 1.0
- Guaranteed interoperability with DVI-compliant transmitters
- Low power standby mode; automatic entry into standby mode with clock detect circuitry
- Lead-free universal packaging (see page 39).

### Sil 1151 Pin Diagram

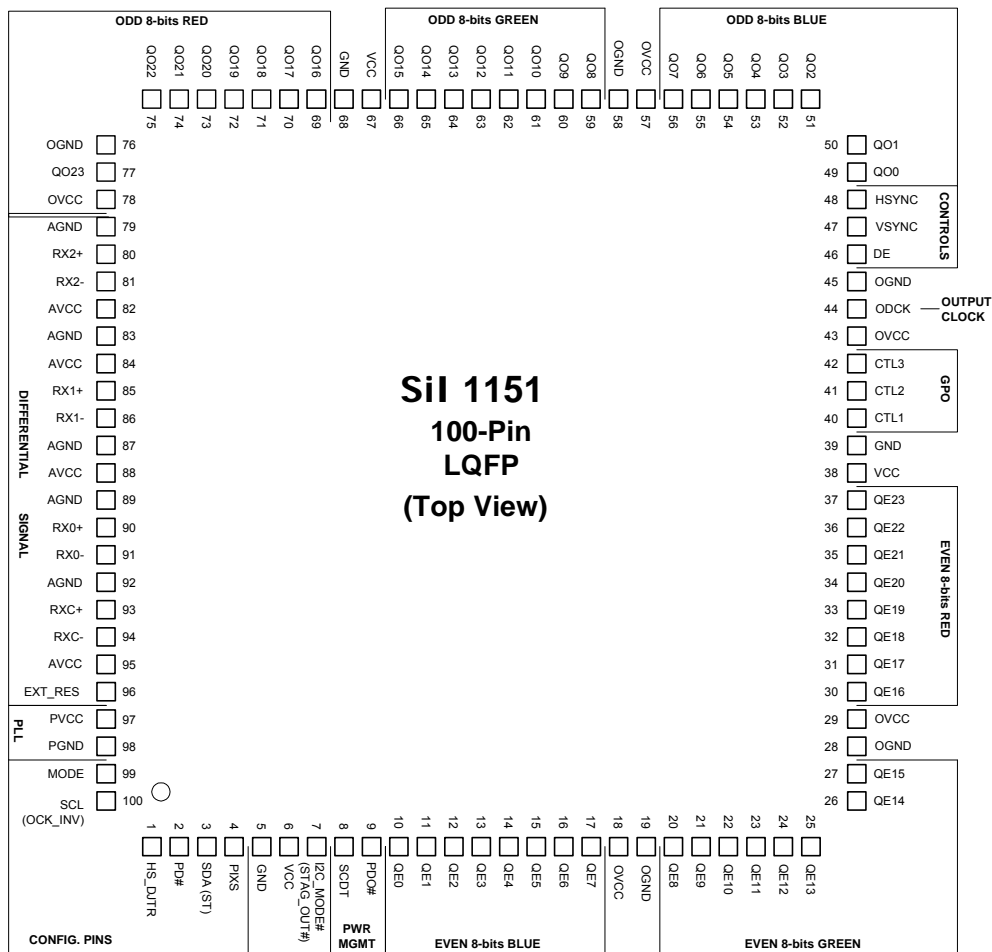

## Functional Description

The SiI 1151 is a DVI 1.0 compliant Panellink receiver in a compact package. It provides 24 or 48 bits for data output, and allows for panel support up to SXGA. Figure 1 shows the functional blocks of the chip.

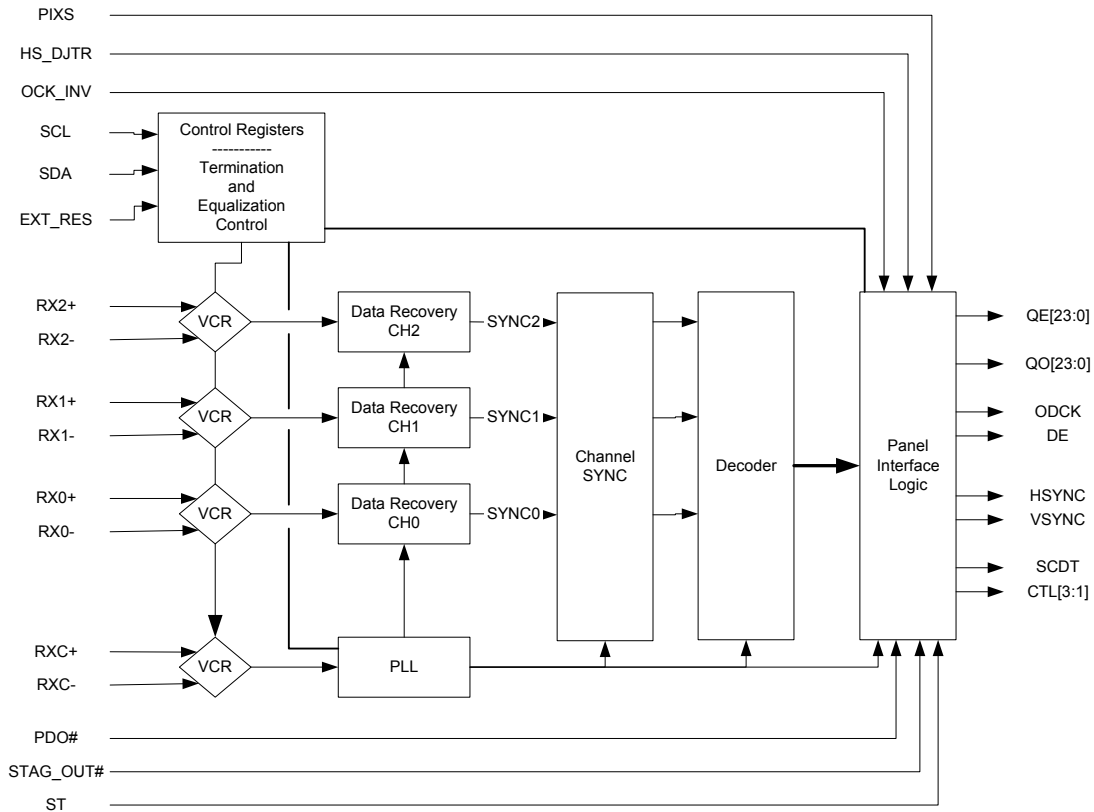

**Figure 1. Functional Block Diagram**

The Panellink TMDs core accepts as inputs the three TMDs differential data lines and the differential clock. The core senses the signals on the link and properly decodes them providing accurate pixel data. The core outputs the necessary sync signals (HSYNC, VSYNC), clock (ODCK), and a DE signal that goes high when the active region of the video is present.

The SCDT signal is output when there is active video on the DVI link and the PLL in the TMDs has locked on to the video. SCDT can be used to trigger external circuitry, indicating that an active video signal is present or used to place the device in power down when no signal is present (by tying it to PDO#). The EXT\_RES component is used for impedance matching.

## Electrical Specifications

### Absolute Maximum Conditions

Symbol	Parameter	Min	Typ	Max	Units	Notes
V <sub>CC</sub>	Supply Voltage 3.3V	-0.3		4.0	V	1
V <sub>I</sub>	Input Voltage	-0.3		V <sub>CC</sub> + 0.3	V	
V <sub>O</sub>	Output Voltage	-0.3		V <sub>CC</sub> + 0.3	V	2
T <sub>J</sub>	Junction Temperature			125	°C	
T <sub>STG</sub>	Storage Temperature	-65		150	°C	

#### Notes

1. Permanent device damage may occur if absolute maximum conditions are exceeded.
2. Functional operation should be restricted to the conditions described under Normal Operating Conditions.

### Normal Operating Conditions

Symbol	Parameter	Min	Typ	Max	Units	Notes
V <sub>CC</sub>	Supply Voltage	3.0	3.3	3.6	V	
V <sub>CCN</sub>	VCC, OVCC Supply Voltage Noise			200	mV <sub>P-P</sub>	
AV <sub>CCN</sub>	AVCC Supply Voltage Noise			100	mV <sub>P-P</sub>	
PV <sub>CCN</sub>	PVCC Supply Voltage Noise			75	mV <sub>P-P</sub>	
T <sub>A</sub>	Ambient Temperature (with power applied)	0	25	70	°C	
θ <sub>JA</sub>	Thermal Resistance (Junction to Ambient)			49	°C/W	

### Digital I/O Specifications

Under normal operating conditions unless otherwise specified.

Symbol	Parameter	Conditions	Min	Typ	Max	Units	Notes
V <sub>IH</sub>	High-level Input Voltage		2			V	
V <sub>IL</sub>	Low-level Input Voltage				0.8	V	
V <sub>OH</sub>	High-level Output Voltage		2.4			V	
V <sub>OL</sub>	Low-level Output Voltage				0.4	V	
V <sub>OL(SDA)</sub>	Low-level Output Voltage on SDA	I <sub>OL(SDA)</sub> = 3mA			0.4	V	
V <sub>CINL</sub>	Input Clamp Voltage	I <sub>CL</sub> = -18mA			GND -0.8	V	1, 2
V <sub>CIPL</sub>	Input Clamp Voltage	I <sub>CL</sub> = 18mA			IVCC + 0.8	V	1, 2
V <sub>CONL</sub>	Output Clamp Voltage	I <sub>CL</sub> = -18mA			GND -0.8	V	1
V <sub>COPL</sub>	Output Clamp Voltage	I <sub>CL</sub> = 18mA			OVCC + 0.8	V	1
I <sub>OL</sub>	Output Leakage Current	High Impedance	-10		10	μA	

#### Note

1. Guaranteed by design. Voltage undershoot or overshoot cannot exceed absolute maximum conditions for a pulse of greater than 3 ns or one third of the clock cycle.
2. Applies to toggling inputs only. Strap selected options are fixed at power-up time.

## General DC Specifications

Under normal operating conditions unless otherwise specified.

**Table 1. DC Parametric Specifications**

Symbol	Parameter	Conditions	Min	Typ	Max	Units	Notes
V <sub>ID</sub>	Differential Input Voltage Single Ended Amplitude		75		1000	mV	
I <sub>PD</sub>	Power-down Current	PD#=LOW, no RXC <sub>±</sub> input			5	mA	3
I <sub>PDO</sub>	Receiver Supply Current with Outputs Powered Down	ODCK=112MHz, 1 pixel per clock mode PDO# = LOW			220	mA	3, 4
I <sub>CCR</sub>	Receiver Supply Current for Active Device	ODCK=112MHz, 0°C 1 pixel per clock mode PDO#=HIGH Typ: Typical Pattern Max: Worst Case Pattern		220	330	mA	1, 2, 4

### Notes

1. The Typical Pattern contains a gray scale area, checkerboard area, and text.
2. The Worst Case Pattern consists of a black and white checkerboard pattern; each checker is two pixels wide.
3. Asserting PD# to LOW disables all internal logic and outputs, including SCDT and clock detect functions. The inactive input clock accounts for most of the power reduction.
4. Specified with capacitive load (C<sub>LOAD</sub>) of 10pF on each output pin, and a worst-case TMDS signal swing of 600mV.



## General AC Specifications

Table 2. General AC Specifications

Symbol	Parameter	Conditions	Min	Typ	Max	Units	Notes
T <sub>DPS</sub>	Intra-Pair (+ to -) Differential Input Skew	112MHz			355	ps	1
T <sub>CCS</sub>	Channel to Channel Differential Input Skew	112MHz			7	ns	1
T <sub>IJIT</sub>	Worst Case Differential Input Clock Jitter tolerance	65 MHz			465	ps	2,3
		112 MHz			270	ps	
R <sub>CIP</sub>	ODCK Cycle Time (one pixel per clock)	one pixel per clock	8		40	ns	1
F <sub>CIP</sub>	ODCK Frequency (one pixel per clock)		25		112	MHz	1
R <sub>CIP</sub>	ODCK Cycle Time (two pixels per clock)	two pixels per clock	17		80	ns	1
F <sub>CIP</sub>	ODCK Frequency (two pixels per clock)		12.5		56	MHz	1
T <sub>DUTY</sub>	Output Clock Duty Cycle		40%		60%		7
T <sub>PDL</sub>	Delay PD# / PDO# Low to high-Z outputs				10	ns	1
T <sub>HSC</sub>	Link disabled (DE inactive) to SCDT low				50	ms	1
T <sub>FSC</sub>	Link enabled (DE active) to SCDT high		4		10	DEedges	1
T <sub>CLKPD</sub>	Delay from RXC+ Inactive to high-Z outputs				10	μs	
T <sub>CLKPU</sub>	Delay from RXC+ active to data active				100	μs	
T <sub>ST</sub>	ODCK high to even data output			0.25		R <sub>CIP</sub>	1
T <sub>I2CDVD</sub>	SDA Data Valid Delay from SCL high to low transition	C <sub>L</sub> = 400pf			700	ns	5
T <sub>CTLW</sub>	Control Pulse Width		2			R <sub>CIP</sub>	6
T <sub>RESET</sub>	PD# Signal Low Time required for a valid I <sup>2</sup> C reset		10			μs	1

### Notes

1. Guaranteed by design.
2. Jitter defined per DVI 1.0 Specification, Section 4.6 – Jitter Specification.
3. Jitter measured with Clock Recovery Unit per DVI 1.0 Specification, Section 4.7 – Electrical Measurement Procedures.
4. Measured with transmitter powered down.
5. All Standard Mode I<sup>2</sup>C (100kHz and 400kHz) timing requirements are guaranteed by design.
6. Control pulses include HSYNC, VSYNC, CTL1, CTL2 and CTL3. Pulses narrower than this minimum width specification are filtered out in the receiver and will not be seen at the output pins.
7. ODCK duty cycle is independent of the differential input clock duty cycle and the transmitter IDCK duty cycle.

DC and AC parameters specific to the operating mode of the SiI 1151 are listed on the following pages.

The output pin timing specifications are dependent on the selection of output drive capability. Specifications are listed for two modes: SiI 151B mode, which requires no I<sup>2</sup>C initialization; and SiI 1151 mode, which allows for optimization of input data recovery and output drive using I<sup>2</sup>C programming. Designers should choose the mode most suited to their board-level requirements.

## Compatibility Mode Selection Specifications

The SiI 1151 design provides new features that were not available on previous TMDS receiver series. To utilize the new features and ensure backwards compatibility, two mode selections have been defined.

**SiI 151B (Compatible) Mode:** This mode allows drop-in replacement of SiI 151B and other pin-compatible receivers, and provides improved performance over other solutions. Strapping MODE (pin 99) = HIGH selects Compatible Mode.

**SiI 1151 (Programmable) Mode.** Superior link recovery performance is possible, along with additional output drive timing margin, when this mode is selected. Strapping MODE (pin 99) = LOW and I2C\_MODE# (pin 7) = LOW selects Programmable Mode.

## SiI 151B (Compatible) Mode DC Specifications

The output drive strength is controlled with the ST pin as indicated in Figure 2.

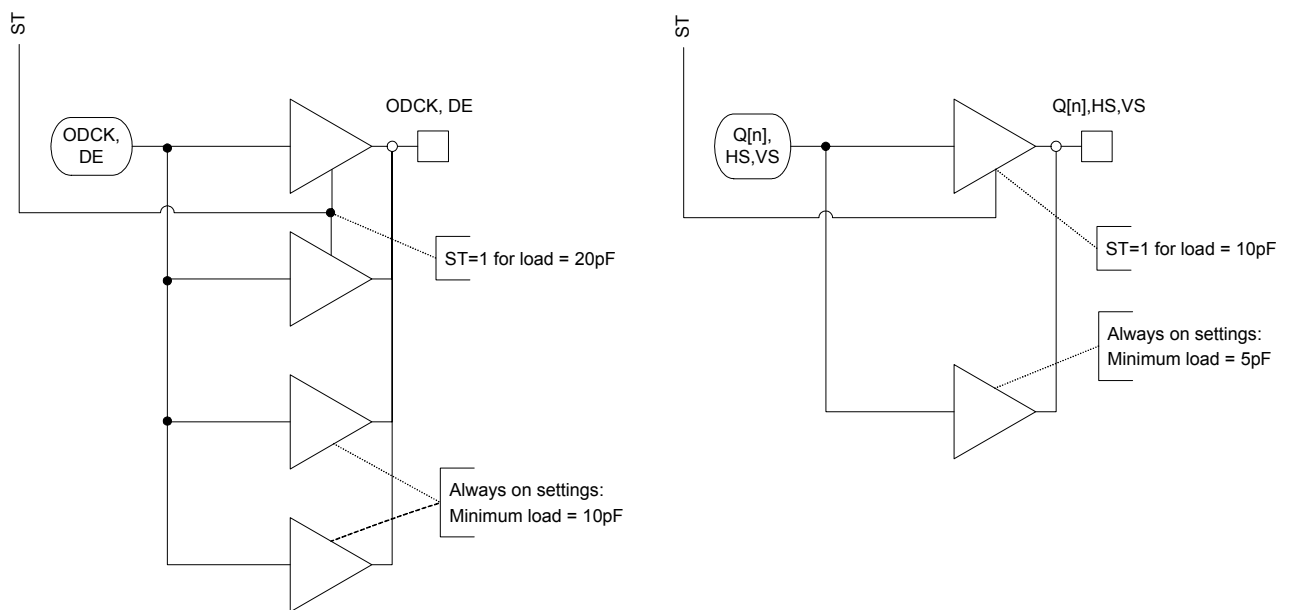

**Figure 2. SiI 151B Mode Control of Output Pin Drive Strength**

The output drive specifications in the Compatible mode are equivalent to the drive on the SiI 151B part.

**Table 3. SiI 151B Mode DC Specifications**

**Strap option: ST=0 (Low Drive Strength)**

Parameter		Conditions			Limits (mA)			Notes
		ST	V <sub>OUT</sub>	C <sub>L</sub>	Min	Typ	Max	
<b>Data and Controls</b>								
I <sub>OHD</sub>	Output High Drive	0	2.4V	5pF	3.8			1
I <sub>OLD</sub>	Output Low Drive	0	0.8V	5pF	5.5			2
		0	0.4V	5pF	3.2			3
<b>ODCK and DE</b>								
I <sub>OHC</sub>	Output High Drive	0	2.4V	10pF	7.5			4
I <sub>OLC</sub>	Output Low Drive	0	0.8V	10pF	11.1			
		0	0.4V	10pF	6.2			

**Strap option: ST=1 (High Drive Strength)**

Parameter		Conditions			Limits (mA)			Notes
		ST	V <sub>OUT</sub>	C <sub>L</sub>	Min	Typ	Max	
<b>Data and Controls</b>								
I <sub>OHD</sub>	Output High Drive	1	2.4V	10pF	7.4			1
I <sub>OLD</sub>	Output Low Drive	1	0.8V	10pF	11.1			2
		1	0.4V	10pF	6.3			3
<b>ODCK and DE</b>								
I <sub>OHC</sub>	Output High Drive	1	2.4V	20pF	14.7			4
I <sub>OLC</sub>	Output Low Drive	1	0.8V	20pF	21.2			
		1	0.4V	20pF	12.3			

**Notes**

1. Output loading is equivalent to one or two CMOS input loads.
2. 0.8V corresponds to LVTTTL V<sub>IN</sub>(max).
3. 0.4V corresponds to LVCMOS V<sub>IN</sub>(max).
4. Output loading is equivalent to two or four CMOS input loads.

## SiI 151B (Compatible) Mode AC Specifications

AC timings are provided here in setup/hold format at 112MHz for ease of direct comparison to the SiI 151B part. Timing specifications in Table 4 apply to worst-case one pixel per clock mode. For other modes and frequencies use the SiI 1151 Mode timings and calculation methodology, "Calculating Setup and Hold Times" on Page 12.

**Table 4. SiI 151B Mode AC Specifications**

Strap option: ST=0 (Low Drive Strength)

Parameter		Conditions	Limits (ns)	
<b>Data, HSYNC, VSYNC</b>				<b>Max</b>
D <sub>HLT</sub>	1-to-0 Transition	C <sub>L</sub> =5pF		2.5
D <sub>LHT</sub>	0-to-1 Transition	C <sub>L</sub> =5pF		2.0
<b>ODCK, DE</b>				<b>Max</b>
D <sub>HLT</sub>	1-to-0 Transition	C <sub>L</sub> =5pF		1.5
D <sub>LHT</sub>	0-to-1 Transition	C <sub>L</sub> =5pF		1.7
<b>Timing @ 112MHz</b>			<b>Min OCK_INV=0</b>	<b>Min OCK_INV=1</b>
T <sub>SETUP</sub>	Data	C <sub>L</sub> =5pF	2.1	2.4
	DE, HSYNC, VSYNC	C <sub>L</sub> =5pF	1.4	1.6
T <sub>HOLD</sub>	Data	C <sub>L</sub> =5pF	4.0	3.6
	DE, HSYNC, VSYNC	C <sub>L</sub> =5pF	4.8	3.8

Strap option: ST=1 (High Drive Strength)

Parameter		Conditions	Limits (ns)	
<b>Data, HSYNC, VSYNC</b>				<b>Max</b>
D <sub>HLT</sub>	1-to-0 Transition	C <sub>L</sub> =10pF		2.5
D <sub>LHT</sub>	0-to-1 Transition	C <sub>L</sub> =10pF		2.0
<b>ODCK, DE</b>				<b>Max</b>
D <sub>HLT</sub>	1-to-0 Transition	C <sub>L</sub> =10pF		1.2
D <sub>LHT</sub>	0-to-1 Transition	C <sub>L</sub> =10pF		1.4
<b>Timing @ 112MHz</b>			<b>Min OCK_INV=0</b>	<b>Min OCK_INV=1</b>
T <sub>SETUP</sub>	Data	C <sub>L</sub> =10pF	2.1	2.4
	DE, HSYNC, VSYNC	C <sub>L</sub> =10pF	1.8	2.3
T <sub>HOLD</sub>	Data	C <sub>L</sub> =10pF	4.0	3.4
	DE, HSYNC, VSYNC	C <sub>L</sub> =10pF	4.3	3.3

### Notes

1. All transitions are specified at worst case of 70°C with minimum VCC.
2. ODCK and DE output pins should be loaded with 10pF when ST=0 and 20pF when ST=1. If layout requires only a point-to-point, one load net, a discrete 10pF capacitor should be added to the net to create these loads. See Figure 3.

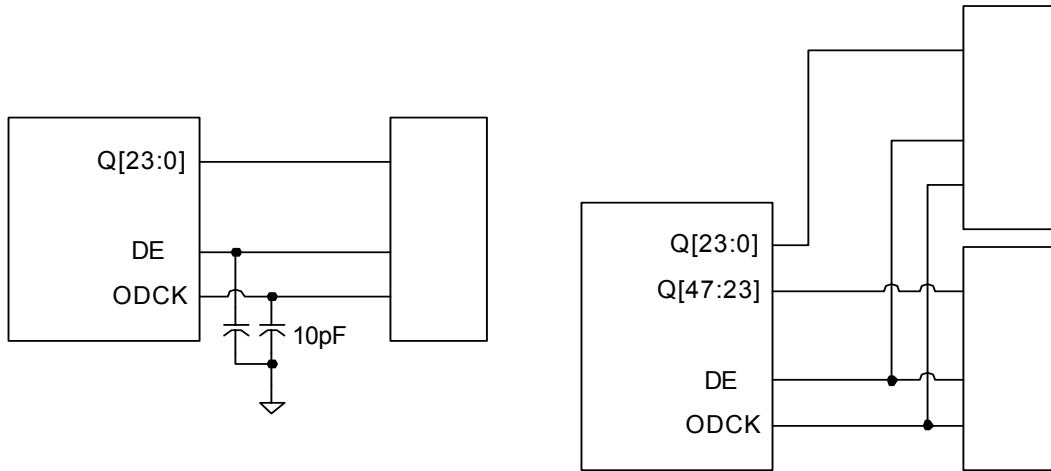

Figure 3. Output Loading in SiI 151B Mode

### SiI 1151 (Programmable) Mode DC Specifications

The SiI 1151 provides an internal register, accessible via I<sup>2</sup>C, to match the drive strengths of the output data, control and ODCK pins. This arrangement allows more flexibility in driving diverse loading configurations as shown in Figure 4.

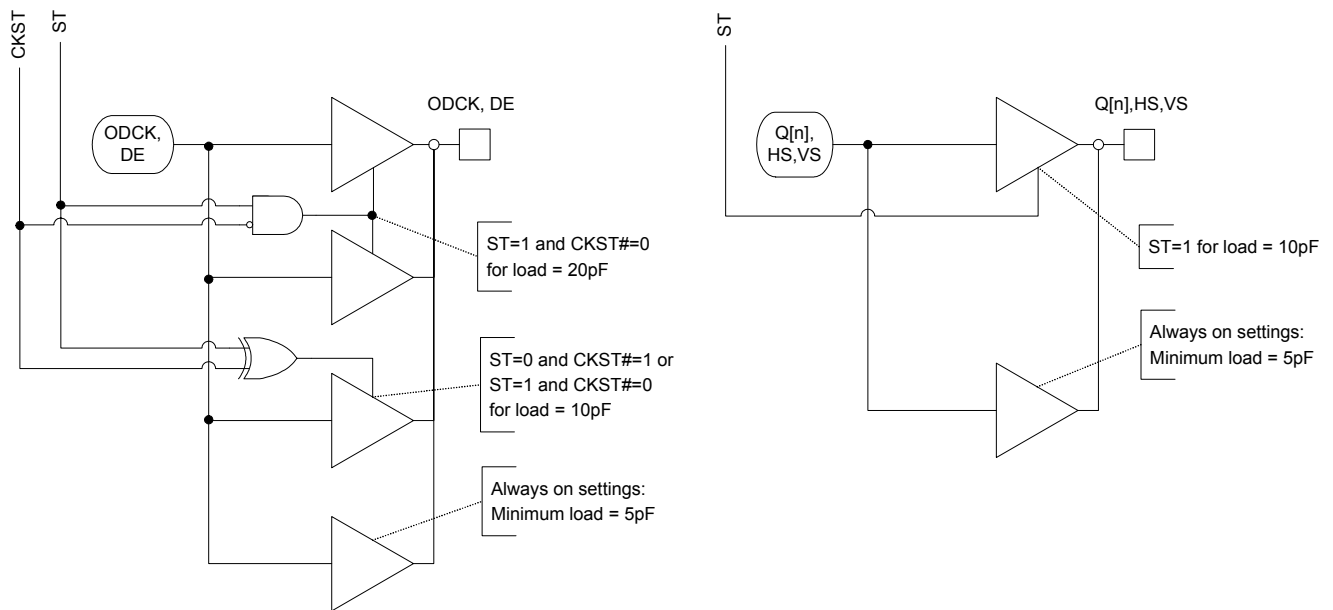

Figure 4. SiI 1151 Mode Control of Output Pin Drive Strength

**Table 5. SiI 1151 Mode DC Specifications**
**Program Option: ST=0<sup>1</sup> (Low Drive Strength)**

Parameter		Conditions		Limits (mA)	Notes
		CKST <sup>1</sup>	V <sub>OUT</sub>	Min	
<b>Data and Controls</b>					
I <sub>OHD</sub>	Output High Drive	X	2.4V	3.8	
I <sub>OLD</sub>	Output Low Drive	X	0.8V	5.5	3
		X	0.4V	3.2	4
<b>ODCK and DE</b>					
I <sub>OHC</sub>	Output High Drive	1	2.4V	3.6	
		0	2.4V	7.5	
I <sub>OLC</sub>	Output Low Drive	1	0.8V	5.4	3
		0	0.8V	11.1	3
		1	0.4V	2.9	4
		0	0.4V	6.2	4

**Program Option: ST=1<sup>1</sup> (High Drive Strength)**

Parameter		Conditions		Limits (mA)	Notes
		CKST <sup>1</sup>	V <sub>OUT</sub>	Min	
<b>Data and Controls</b>					
I <sub>OHD</sub>	Output High Drive	X	2.4V	7.4	
I <sub>OLD</sub>	Output Low Drive	X	0.8V	11.1	3
		X	0.4V	6.3	4
<b>ODCK and DE</b>					
I <sub>OHC</sub>	Output High Drive	1	2.4V	7.2	
		0	2.4V	14.7	
I <sub>OLC</sub>	Output Low Drive	1	0.8V	10.4	3
		0	0.8V	21.2	3
		1	0.4V	6.0	4
		0	0.4V	12.3	4

**Notes**

1. CKST and ST are controlled with bits in an I<sup>2</sup>C register, not from pins, in Programmable Mode.
2. Output loading is equivalent to one, two or four CMOS input loads.
3. 0.8V corresponds to LVTTTL V<sub>IN</sub>(max).
4. 0.4V corresponds to LVCMOS V<sub>IN</sub>(max).

### SiI 1151 (Programmable) Mode AC Specifications

SiI 1151 Mode AC timings are based on “Clock to Output” (CK2OUT) timing measurements. This methodology provides a precise means of calculating setup and hold at any frequency and in any chip operating mode.  $C_L$  indicates the load on the ODCK line. The load on the data/control line involved depends on CKST: for CKST=1, the control/data pin load is  $C_L$ ; for CKST=0, the load is  $2x C_L$ .

**Table 6. SiI 1151 Mode AC Specifications**

**Program Option: ST=0 (Low Drive Strength)**

Parameter		Conditions			Limits (ns)			
Data, HSYNC, VSYNC		CKST	ST	$C_L$				Max
$D_{HLT}$	1-to-0 Transition	X	0	5pF				2.5
$D_{LHT}$	0-to-1 Transition	X	0	5pF				2.0
ODCK, DE		CKST	ST	$C_L$				Max
$D_{HLT}$	1-to-0 Transition	1	0	5pF	1X clock drive			2.5
		0	0	10pF	2X clock drive			1.5
$D_{LHT}$	0-to-1 Transition	1	0	5pF	1X clock drive			2.7
		0	0	10pF	2X clock drive			1.7
Clock-to-Output Timing		CKST	ST	$C_L$	Min		Max	
					OCK_INV Setting →			
					0	1	0	1
$T_{CK2OUT}$	ODCK to Data	1	0	5pF	0.4	0.0	1.5	1.2
		0	0	10pF	0.4	-0.1	1.5	1.0
$T_{CK2OUT}$	ODCK to DE, HSYNC, VSYNC	1	0	5pF	1.2	0.2	2.2	2.0
		0	0	10pF	0.8	0.1	2.2	1.7

**Program Option: ST=1 (High Drive Strength)**

Parameter		Conditions			Limits (ns)			
Data, HSYNC, VSYNC		CKST	ST	$C_L$				Max
$D_{HLT}$	1-to-0 Transition	X	1	10pF				2.5
$D_{LHT}$	0-to-1 Transition	X	1	10pF				2.0
ODCK, DE		CKST	ST	$C_L$				Max
$D_{HLT}$	1-to-0 Transition	1	1	10pF	2X clock drive			1.9
		0	1	20pF	4X clock drive			1.2
$D_{LHT}$	0-to-1 Transition	1	1	10pF	2X clock drive			1.7
		0	1	20pF	4X clock drive			1.4
Clock-to-Output Timing		CKST	ST	$C_L$	Min		Max	
					OCK_INV Setting →			
					0	1	0	1
$T_{CK2OUT}$	ODCK to Data	1	1	10pF	0.4	-0.2	1.5	1.2
		0	1	20pF	0.0	-0.8	1.4	1.0
$T_{CK2OUT}$	ODCK to DE, HSYNC, VSYNC	1	1	10pF	0.7	-0.3	1.8	1.3
		0	1	20pF	0.1	-0.3	1.9	1.0

**Notes**

1. Output loading is equivalent to one (5pF), two (10pF) or four (20pF) CMOS input loads.
2. All transition time specifications at 70°C, minimum VCC.
3. Timing specifications in Table 6 apply to both one pixel per clock and two pixel per clock modes.

## Calculating Setup and Hold Times

Output setup and hold times between video output clock (ODCK) and video data (including HSYNC, VSYNC and DE) are functions of the worst case duty cycle specification for ODCK and the worst case clock to output delay. For the SiI 1151 output pins, only the minimum output setup and hold times are critical.

The SiI 1151 provides the OCK\_INV feature, described on page 22, to allow external logic to decode data with either a rising or falling clock edge.

### OCK\_INV=0 Case

For OCK\_INV=0, the worst-case setup time occurs when the clock to output delay is at a maximum (latest data) and the ODCK duty cycle is at a minimum (earliest falling edge). Conversely, the worst case hold time occurs when the clock to output delay is at a minimum (earliest next data) and the ODCK duty cycle is at a maximum (latest falling edge). This is shown in Figure 5. The falling active ODCK edge is shown with an arrowhead.

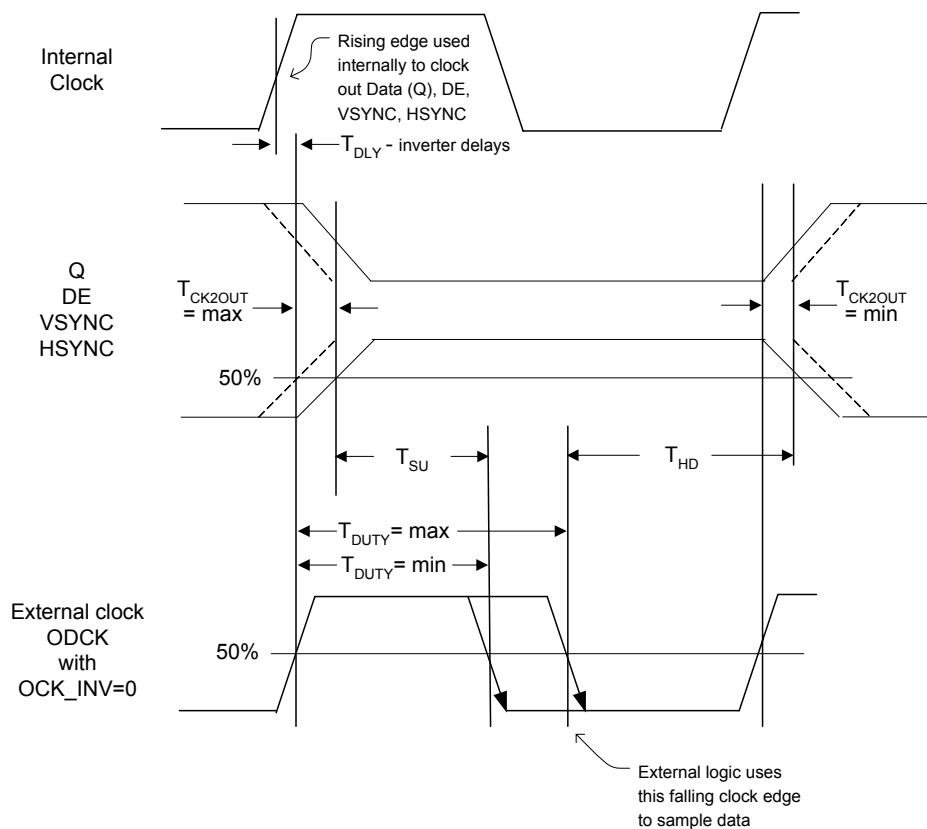

**Figure 5. Receiver Output Setup and Hold Times – OCK\_INV=0**

**Note:** For Staggered Output timing in 2Pix/clk mode, refer to Figure 15.

Actual setup and hold times can be derived from the clock period at the operating frequency of interest. Clock duty cycle must also be taken into account when calculating setup and hold times.

$$\text{Setup Time to ODCK: } T_{\text{ODCK}} * T_{\text{DUTY}\{\text{min}\}} - T_{\text{CK2OUT}\{\text{max}\}}$$

$$\text{Hold Time from ODCK: } T_{\text{ODCK}} * (1 - T_{\text{DUTY}\{\text{max}\}}) + T_{\text{CK2OUT}\{\text{min}\}}$$



Table 7 shows the calculations required for determining setup and hold timings using the clock period  $T_{ODCK}$  specific to the clock frequency, also bringing in the clock duty cycle as required when  $OCK\_INV=0$ . The setup and hold times apply to DE, VSYNC, HSYNC and Data output pins, as long as the appropriate  $T_{CK2OUT}$  value is used for the calculation in each case. The table also shows calculated setup and hold times for commonly used ODCK frequencies.

**Table 7. Sample Calculation of Data Output Setup and Hold Times –  $OCK\_INV=0$**

Symbol	Parameter	Frequency	$T_{ODCK}$	$T_{CK2OUT}$ (data)	Result
$T_{SU}$	<b>Data Setup Time to ODCK</b> = $T_{ODCK} * T_{DUTY}\{min\}$ - $T_{CK2OUT}\{max\}$	25 MHz	40 ns	Max	= $40 * 40\% - 1.5 = 14.5ns$
		82.5 MHz	12 ns	=1.5	= $12 * 40\% - 1.5 = 3.3ns$
		112 MHz	9 ns		= $9 * 40\% - 1.5 = 2.1ns$
$T_{HD}$	<b>Data Hold Time from ODCK</b> = $T_{ODCK} * (1 - T_{DUTY}\{max\})$ + $T_{CK2OUT}\{min\}$	25 MHz	40 ns	Min	= $40 * 40\% + 0.4 = 16.4ns$
		82.5 MHz	12 ns	=0.4	= $12 * 40\% + 0.4 = 5.2ns$
		112 MHz	9 ns		= $9 * 40\% + 0.4 = 4.0ns$

**$OCK\_INV=1$  Case**

For  $OCK\_INV=1$ , the timing is similar to that previously discussed. The worst-case setup time occurs when the clock to output delay is at a maximum (latest data) and the ODCK duty cycle is at a minimum (earliest falling edge). Conversely, the worst case hold time occurs when the clock to output delay is at a minimum (earliest next data) and the ODCK duty cycle is at a maximum (latest falling edge). This timing relationship is shown in Figure 6. The rising active ODCK edge is shown with an arrowhead.

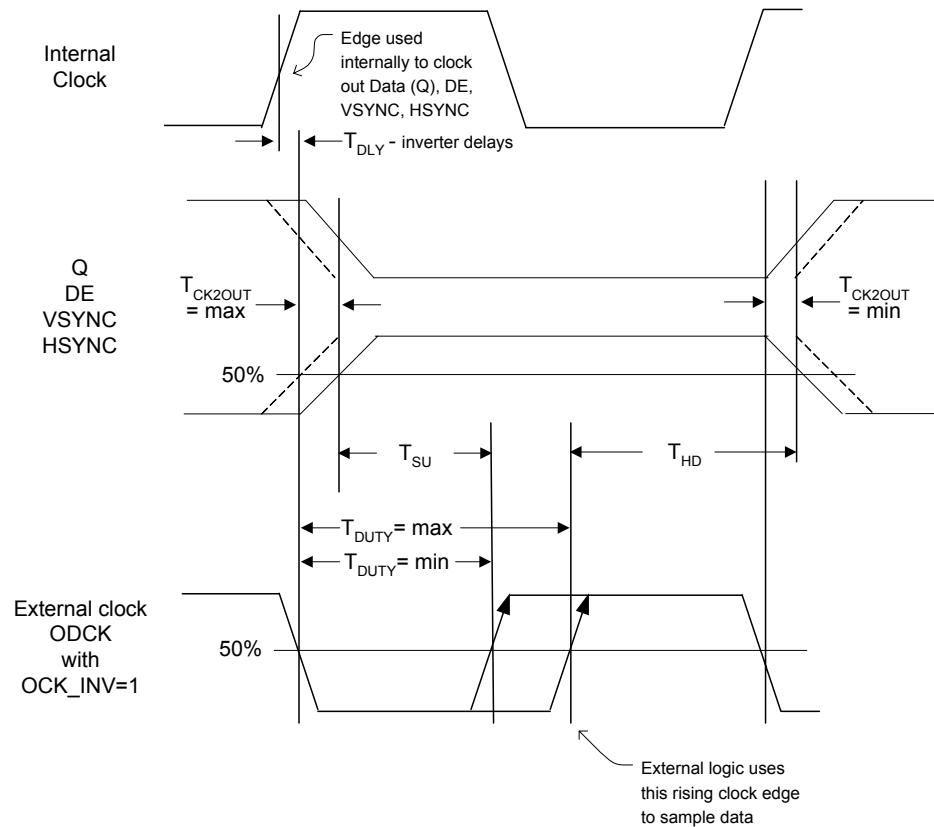

**Figure 6. Receiver Output Setup and Hold Times –  $OCK\_INV=1$**   
**Note:** For Staggered Output timing in 2Pix/clock mode, refer to Figure 15.

Actual setup and hold times can be derived from the clock period at the operating frequency of interest. Clock duty cycle must also be taken into account when calculating setup and hold times.

$$\text{Setup Time to ODCK: } T_{\text{ODCK}} * T_{\text{DUTY}\{\text{min}\}} - T_{\text{CK2OUT}\{\text{max}\}}$$

$$\text{Hold Time from ODCK: } T_{\text{ODCK}} * (1 - T_{\text{DUTY}\{\text{max}\}}) + T_{\text{CK2OUT}\{\text{min}\}}$$

Table 8 shows the calculations required for determining setup and hold timings using the clock period  $T_{\text{ODCK}}$  specific to the clock frequency when  $\text{OCK\_INV}=1$ . The setup and hold times apply to DE, VSYNC, HSYNC and Data output pins, as long as the appropriate  $T_{\text{CK2OUT}}$  value is used for the calculation in each case. The table also shows calculated setup and hold times for commonly used ODCK frequencies.

**Table 8. Sample Calculation of Data Output Setup and Hold Times – OCK\_INV=1**

Symbol	Parameter	Frequency	$T_{\text{ODCK}}$	$T_{\text{CK2OUT}}$ (data)	Result
$T_{\text{SU}}$	<b>Data Setup Time to ODCK</b> = $T_{\text{ODCK}} * T_{\text{DUTY}\{\text{min}\}} - T_{\text{CK2OUT}\{\text{max}\}}$	25 MHz	40 ns	Max	= $40 * 40\% - 1.2 = 14.8\text{ns}$
		82.5 MHz	12 ns	=1.2	= $12 * 40\% - 1.2 = 3.6\text{ns}$
		112 MHz	9 ns		= $9 * 40\% - 1.2 = 2.4\text{ns}$
$T_{\text{HD}}$	<b>Data Hold Time from ODCK</b> = $T_{\text{ODCK}} * (1 - T_{\text{DUTY}\{\text{max}\}}) + T_{\text{CK2OUT}\{\text{min}\}}$	25 MHz	40 ns	Min	= $40 * 40\% - 0.0 = 16.0\text{ns}$
		82.5 MHz	12 ns	=0.0	= $12 * 40\% - 0.0 = 4.8\text{ns}$
		112 MHz	9 ns		= $9 * 40\% - 0.0 = 3.6\text{ns}$

## Timing Diagrams

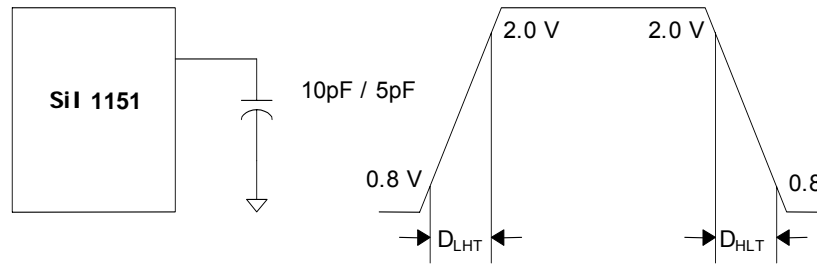

Figure 7. Digital Output Transition Times

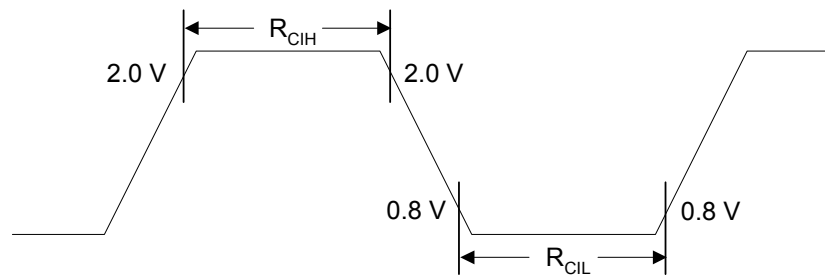

Figure 8. Receiver Clock Cycle/High/Low Times

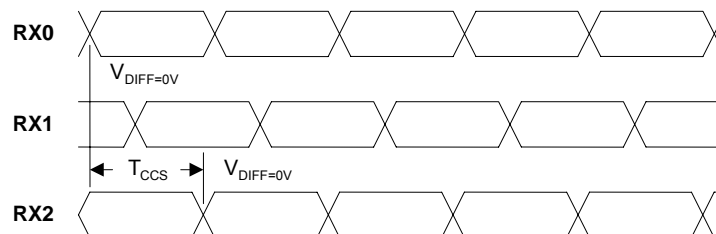

Figure 9. Channel-to-Channel Skew Timing

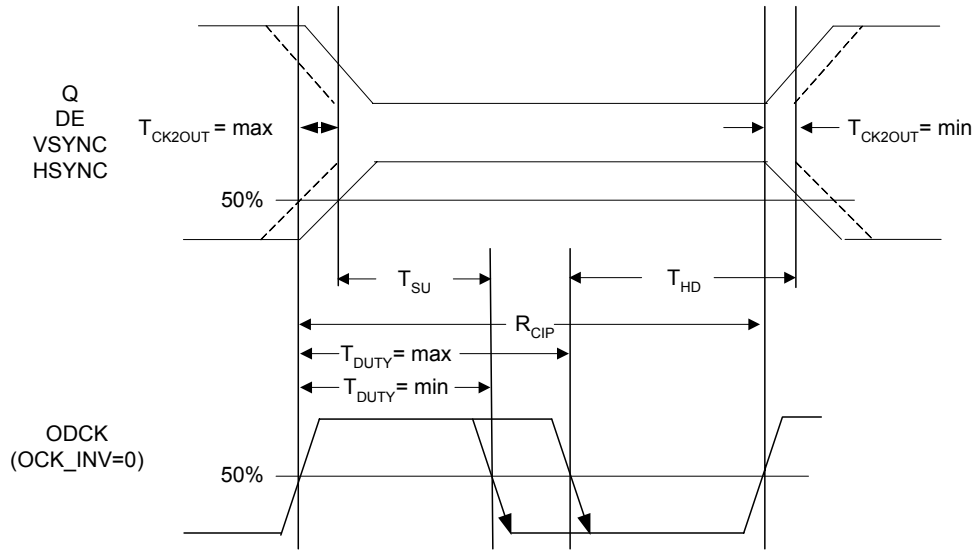

Figure 10. Receiver Clock-to-Output Delay and Duty Cycle Limits

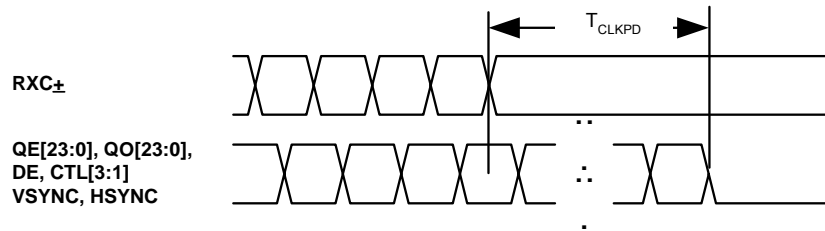

Figure 11. Output Signals Disabled Timing from Clock Inactive

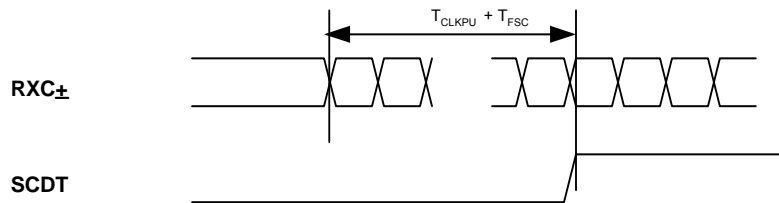

Figure 12. Wake-Up on Clock Detect

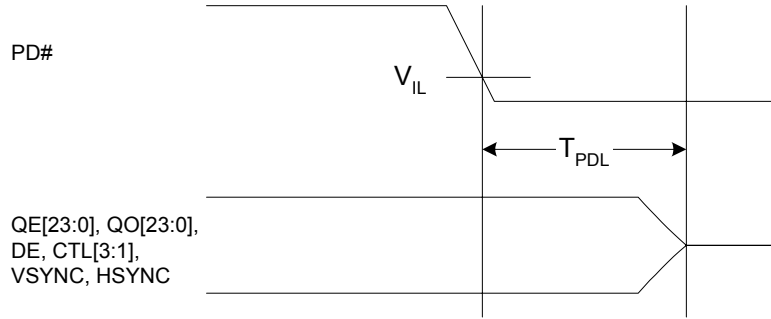

Figure 13. Output Signals Disabled Timing from PD# Active

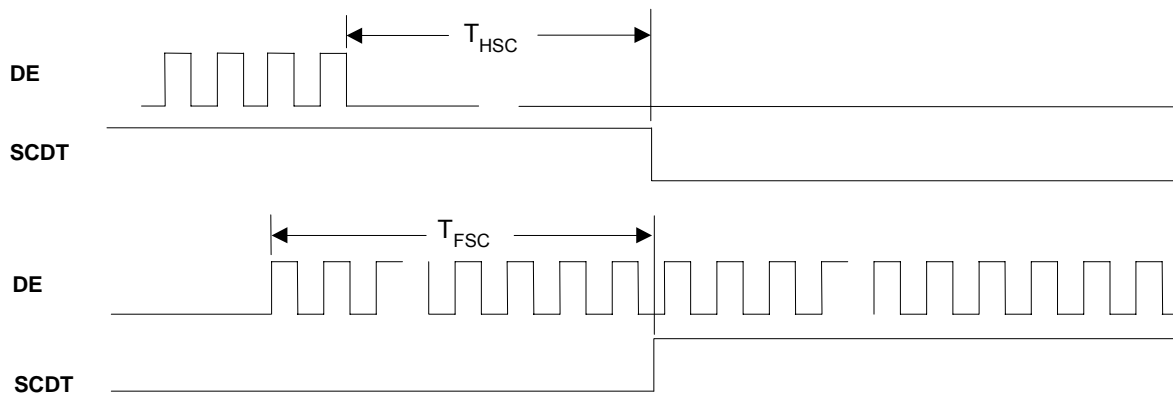

Figure 14. SCDT Timing from DE Inactive or Active

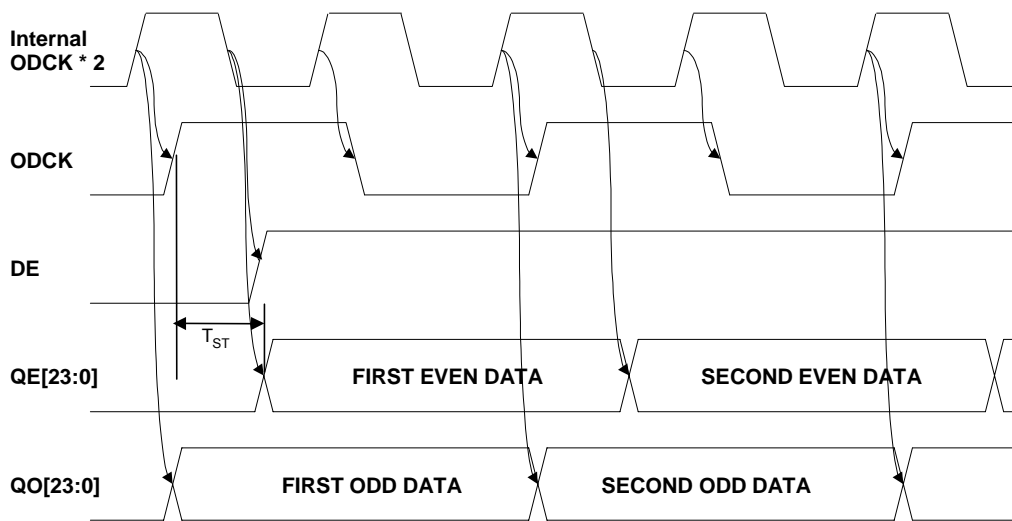
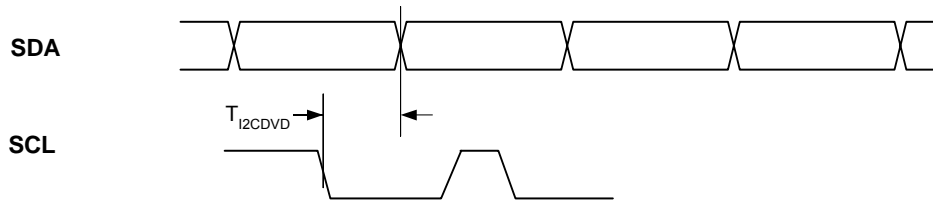
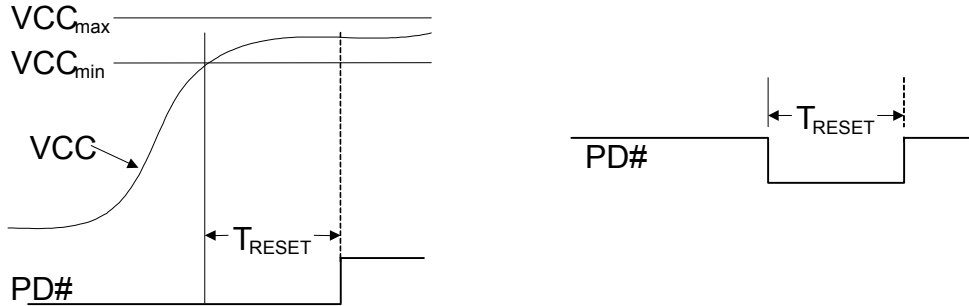

Figure 15. Two Pixels per Clock Staggered Output Timing Diagram



**Figure 16. I<sup>2</sup>C Data Valid Delay (driving Read Cycle data)**



**Figure 17. I<sup>2</sup>C Reset Timing at Power-Up or Prior to first I<sup>2</sup>C Access**

## Pin Descriptions

### Output Pins

Pin Name	Pin #	Type	Description
QE23- QE0	See SiI 1151 Pin Diagram	Out	Output Even Data[23:0] corresponds to 24-bit pixel data for one pixel per clock input mode and to the first 24-bit pixel data for two pixels per clock mode. Output data is synchronized with output data clock (ODCK). Refer to the TFT Panel Data Mapping section, which tabulates the relationship between the input data to the transmitter and output data from the receiver. A low level on PD# or PDO# will put the output drivers into a high impedance (tri-state) mode. A weak internal pull-down device brings each output to ground.
QO23- QO0	See SiI 1151 Pin Diagram	Out	Output Odd Data[23:0] corresponds to the second 24-bit pixel data for two pixels per clock mode. During one pixel per clock mode, these outputs are driven low. Output data is synchronized with output data clock (ODCK). Refer to the TFT Panel Data Mapping section, which tabulates the relationship between the input data to the transmitter and output data from the receiver. A low level on PD# or PDO# will put the output drivers into a high impedance (tri-state) mode. A weak internal pull-down device brings each output to ground.
ODCK	44	Out	Output Data Clock. This output can be inverted using the OCK_INV pin. A low level on PD# or PDO# will put the output driver into a high impedance (tri-state) mode. A weak internal pull-down device brings the output to ground.
DE	46	Out	Output Data Enable. This signal qualifies the active data area. A HIGH level signifies active display time and a LOW level signifies blanking time. This output signal is synchronized with the output data. A low level on PD# or PDO# will put the output driver into a high impedance (tri-state) mode. A weak internal pull-down device brings the output to ground.
HSYNC VSYNC CTL1 CTL2 CTL3	48 47 40 41 42	Out	Horizontal Sync output control signal. Vertical Sync output control signal. General output control signal 1. This output is <b>not</b> powered down by PDO#. General output control signal 2. General output control signal 3. A low level on PD# or PDO# will put the output drivers (except CTL1 by PDO#) into a high impedance (tri-state) mode. A weak internal pull-down device brings each output to ground.

### Differential Signal Data Pins

Pin Name	Pin #	Type	Description
RX0+ RX0- RX1+ RX1- RX2+ RX2-	90 91 85 86 80 81	Analog	Receiver Differential Data Pins. TMDS Low Voltage Differential Signal input data pairs.
RXC+ RXC-	93 94	Analog	Receiver Differential Clock Pins. TMDS Low Voltage Differential Signal input clock pair.
EXT_RES	96	Analog	Impedance Matching Control. An external 390Ω resistor must be connected between AVCC and this pin.

## Configuration Pins

Pin Name	Pin #	Type	Description
MODE	99	In	Mode Select Pin. Used to select between drop-in strap-selected operation, or register-programmable operation. To activate register-programmable operation, tie both pin 99 and pin 7 LOW. Refer to Selecting SiI 1151 (Programmable) Mode on page 31 for more details. HIGH=151B (Compatible) Mode – strap selections are used to set part operation. Internal registers controlling non strap-selectable functions are reset to their default values. LOW= SiI 1151 (Programmable) Mode – I <sup>2</sup> C registers are used to program part operation.
OOCK_INV	100	In	ODCK Polarity. A LOW level selects normal ODCK output. A HIGH level selects inverted ODCK output. All other output signals are unaffected by this pin. They will maintain the same timing no matter the setting of OOCK_INV pin
SCL			I <sup>2</sup> C Port Clock. When pins 99 and 7 are tied LOW, pin 100 functions as an I <sup>2</sup> C port input clock. The slave I <sup>2</sup> C function does not ever try to extend cycles by pulling this pin low, so the pin remains input-only at all times. Refer to Selecting SiI 1151 (Programmable) Mode on page 31 for more details. This pin accepts 3.3V signaling only; it is not 5V-tolerant.
PIXS	4	In	Pixel Select. A LOW level indicates one pixel (up to 24-bits) per clock mode using QE[23:0]. A HIGH level indicates two pixels (up to 48-bits) per clock mode using QE[23:0] for first pixel and QO[23:0] for second pixel.
STAG_OUT#	7	In	Staggered Output. A HIGH level selects normal simultaneous outputs on all odd and even data lines. A LOW level selects staggered output drive. This function is only available in two pixels per clock mode.
I2C_MODE#			This pin must be tied LOW to put the receiver into I <sup>2</sup> C mode. Refer to Selecting SiI 1151 (Programmable) Mode on page 31 for more details.
ST	3	In/ Out	Output Drive. A HIGH level selects HIGH output drive strength. A LOW level selects LOW output drive strength.
SDA			I <sup>2</sup> C Port Data. When pins 99 and 7 are tied LOW, pin 3 functions as an I <sup>2</sup> C port data I/O signal. Refer to Selecting SiI 1151 (Programmable) Mode on page 31 for more details. This pin accepts 3.3V signaling only; it is not 5V-tolerant. The I <sup>2</sup> C address of the SiI 1151 is 0x76
HS_DJTR	1	In	HSYNC De-jitter. This pin enables/disables the HSYNC de-jitter function. To enable the HSYNC de-jitter function this pin should be HIGH. To disable the HSYNC de-jitter function this pin should be LOW.

## Power Management Pins

Pin Name	Pin #	Type	Description
SCDT	8	Out	Sync Detect. A HIGH level is outputted when DE is actively toggling indicating that the link is alive. A LOW level is outputted when DE is inactive, indicating the link is down. Can be connected to PDO# to power down the outputs when DE is not detected. The SCDT output itself, however, remains in the active mode at all times.
PDO#	9	In	Output Driver Power Down (active LOW). A HIGH level indicates normal operation. A LOW level puts all the output drivers only (except SCDT and CTL1) into a high impedance (tri-state) mode. A weak internal pull-down device brings each output to ground. PDO# is a sub-set of the PD# description. The chip is not in power-down mode with this pin. SCDT and CTL1 are not tri-stated by this pin. I <sup>2</sup> C access to the registers is available when PDO#=0.
PD#	2	In	Power Down (active LOW). A HIGH level indicates normal operation. A LOW level indicates power down mode. During power down mode, all the output drivers are put into a high impedance (tri-state) mode. A weak internal pull-down device brings each output to ground. Additionally, all analog logic is powered down, and all inputs are disabled. Driving PD# LOW disables all internal logic and outputs, including SCDT and clock detect functions; it also resets all internal programmable registers to their default states. I <sup>2</sup> C access to the registers is disabled when PD#=0.



## Power and Ground Pins

Pin Name	Pin #	Type	Description
VCC	6,38,67	Power	Digital Core VCC, must be set to 3.3V.
GND	5,39,68	Ground	Digital Core GND.
OVCC	18,29,43,57,78	Power	Output VCC, must be set to 3.3V.
OGND	19,28,45,58,76	Ground	Output GND.
AVCC	82,84,88,95	Power	Analog VCC must be set to 3.3V.
AGND	79,83,87,89,92	Ground	Analog GND.
PVCC	97	Power	PLL Analog VCC must be set to 3.3V.
PGND	98	Ground	PLL Analog GND.

## Feature Information

### HSYNC De-jitter Function

HSYNC de-jitter enables the SiI 1151 to operate properly even when the HSYNC signal contains jitter. Pin 1 is used to enable or disable this circuit. Tying this pin high enables the HSYNC de-jitter circuitry while tying it low disables the circuitry. The HSYNC de-jitter circuitry operates normally with most VESA standard timings. In most modes, HSYNC and VSYNC total times and front and back porch times are multiples of four pixel times. If the timings are not a multiple of four, operation is not guaranteed and the HSYNC de-jitter circuitry should be turned off. When HSYNC de-jitter is enabled, the circuitry will introduce anywhere from 1 to 4 CLK delays in the HSYNC signal relative to the output data.

### Clock Detect Function

The SiI 1151 includes a power saving feature: power down with clock detect circuit. The SiI 1151 will go into a low power mode when there is no video clock coming from the transmitter. In this mode, the entire chip is powered down except the clock detect circuitry. During this mode, digital I/O are set to a high impedance (tri-state) mode. The SCDT pin is driven LOW. A weak internal pull-down device brings each output to ground. The device power down and wake-up times are shown in Figure 11 and Figure 12.

### OCK\_INV Function

OCK\_INV affects the phase of the clock output as indicated in Figure 18. The setting of OCK\_INV is selected by a strap pin when in SiI 151B (Compatible) mode, and by a register bit when in SiI 1151 (Programmable) mode.

OCK\_INV does not change the timing for the internal data latching. As shown in the figure, the clock normally passes through two inverters, each with delay  $T_{INV}$ . However, when OCK\_INV is set to 1, the output clock only passes through a single inverter.

This timing is described in the Calculating Setup and Hold Times section.

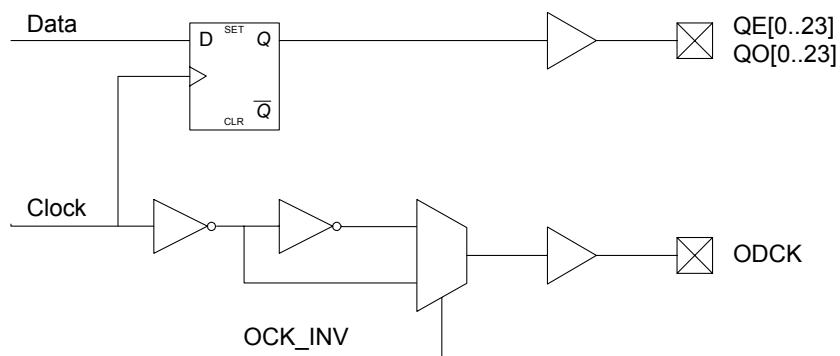

Figure 18. Block Diagram for OCK\_INV

## I<sup>2</sup>C Slave Interface

The SiI 1151 slave state machine supports only byte read and write. Page mode is not supported. The 7-bit binary address of the I<sup>2</sup>C machine is 0x76. Please see Figure 19 for a byte read operation and Figure 20 for a byte write operation. For more detailed information on I<sup>2</sup>C protocols please refer to I<sup>2</sup>C Bus Specification version 2.1 available from Philips Semiconductors Inc.

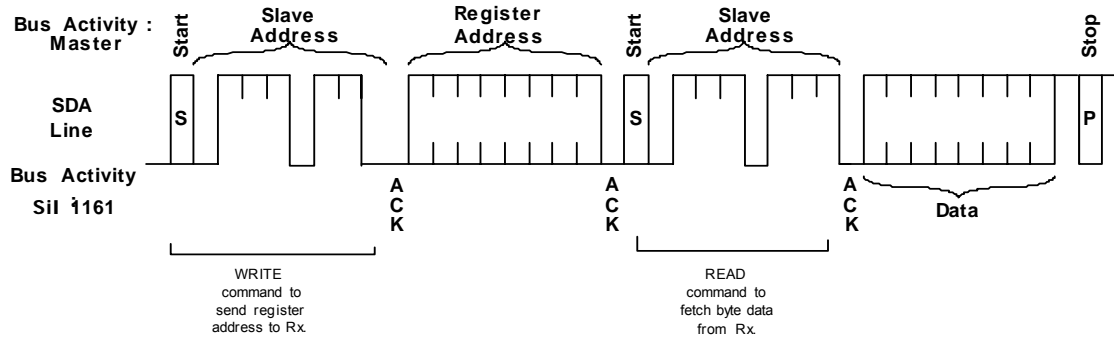

Figure 19. I<sup>2</sup>C Byte Read

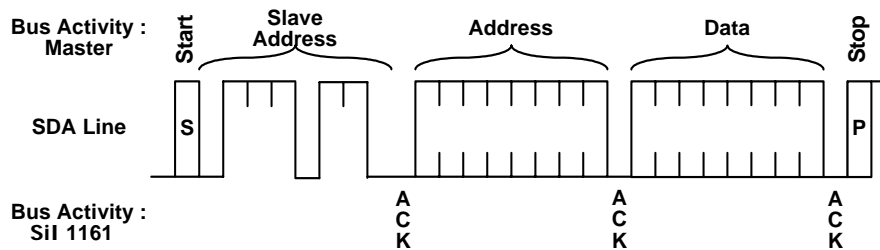

Figure 20. I<sup>2</sup>C Byte Write

**NOTE:**The I<sup>2</sup>C registers can be accessed even when there is no incoming video.

## TFT Panel Data Mapping

Table 9 summarizes the output data mapping in one pixel per clock mode for the SiI 1151. This output data mapping is dependent upon the PanelLink transmitters having the exact same type of input data mappings.

Table 10 summarizes the output data mapping in two pixels per clock mode. More detailed mapping information is found on the following pages. Refer to application note SiI-AN-0007 for DSTN applications.

Note that the data configuration of the receiver is independent of the configuration of the transmitter. The data is always transmitted across the link in the same format, regardless of the selection of 12, 24 or 48 bit input format. Therefore, display-side designers do not need to know how the transmitter is configured. Receiver configuration is for compatibility with the display, not the transmitter.

**Table 9. One Pixel per Clock Mode Data Mapping**

DATA	SiI 1151	
	One Pixel per Clock Output	
	18bpp	24bpp
BLUE[7:0]	QE[7:2]	QE[7:0]
GREEN[7:0]	QE[15:10]	QE[15:8]
RED[7:0]	QE[23:18]	QE[23:16]

**Table 10. Two Pixel per Clock Mode Data Mapping**

DATA	SiI 1151	
	Two Pixel per Clock Output	
	18bpp	24bpp
BLUE[7:0] – 0	QE[7:2]	QE[7:0]
GREEN[7:0] – 0	QE[15:10]	QE[15:8]
RED[7:0] – 0	QE[23:18]	QE[23:16]
BLUE[7:0] – 1	QO[7:2]	QO[7:0]
GREEN[7:0] – 1	QO[15:10]	QO[15:8]
RED[7:0] – 1	QO[23:18]	QO[23:16]

**Note:** Sil143B, Sil 151B, Sil 153B and Sil 1151 all have the same pinout. The pin assignments shown in the following tables should also be used for these other receivers.

**Table 11. One Pixel per Clock Input/Output TFT Mode – VESA P&D and FPGI-2™ Compliant**

TFT VGA Output		Tx Input Data		Rx Output Data		TFT Panel Input	
24-bpp	18-bpp	160	164	1151	141B	24-bpp	18-bpp
B0		DIE0	D0	QE0	Q0	B0	
B1		DIE1	D1	QE1	Q1	B1	
B2	B0	DIE2	D2	QE2	Q2	B2	B0
B3	B1	DIE3	D3	QE3	Q3	B3	B1
B4	B2	DIE4	D4	QE4	Q4	B4	B2
B5	B3	DIE5	D5	QE5	Q5	B5	B3
B6	B4	DIE6	D6	QE6	Q6	B6	B4
B7	B5	DIE7	D7	QE7	Q7	B7	B5
G0		DIE8	D8	QE8	Q8	G0	
G1		DIE9	D9	QE9	Q9	G1	
G2	G0	DIE10	D10	QE10	Q10	G2	G0
G3	G1	DIE11	D11	QE11	Q11	G3	G1
G4	G2	DIE12	D12	QE12	Q12	G4	G2
G5	G3	DIE13	D13	QE13	Q13	G5	G3
G6	G4	DIE14	D14	QE14	Q14	G6	G4
G7	G5	DIE15	D15	QE15	Q15	G7	G5
R0		DIE16	D16	QE16	Q16	R0	
R1		DIE17	D17	QE17	Q17	R1	
R2	R0	DIE18	D18	QE18	Q18	R2	R0
R3	R1	DIE19	D19	QE19	Q19	R3	R1
R4	R2	DIE20	D20	QE20	Q20	R4	R2
R5	R3	DIE21	D21	QE21	Q21	R5	R3
R6	R4	DIE22	D22	QE22	Q22	R6	R4
R7	R5	DIE23	D23	QE23	Q23	R7	R5
Shift CLK	Shift CLK	IDCK	IDCK	ODCK	ODCK	Shift CLK	Shift CLK
VSYNC	VSYNC	VSYNC	VSYNC	VSYNC	VSYNC	VSYNC	VSYNC
HSYNC	HSYNC	HSYNC	HSYNC	HSYNC	HSYNC	HSYNC	HSYNC
DE	DE	DE	DE	DE	DE	DE	DE

For 18-bit mode, the Flat Panel Graphics Controller interfaces to the Transmitter exactly the same as in the 24-bit mode; however, 6 bits per channel (color) are used instead of 8. It is recommended that unused data bits be tied low. As can be seen from the above table, the data mapping for less than 24-bit per pixel interfaces are MSB justified. The data is sent during active display time while the control signals are sent during blank time. Note that the three data channels (CH0, CH1, CH2) are mapped to Blue, Green and Red data respectively.

**Table 12. Two Pixels per Clock Input/Output TFT Mode**

TFT VGA Output		Tx Input Data	Rx Output Data	TFT Panel Input	
24-bpp	18-bpp	160	1151	24-bpp	18-bpp
B0 – 0		DIE0	QE0	B0 – 0	
B1 – 0		DIE1	QE1	B1 – 0	
B2 – 0	B0 – 0	DIE2	QE2	B2 – 0	B0 – 0
B3 – 0	B1 – 0	DIE3	QE3	B3 – 0	B1 – 0
B4 – 0	B2 – 0	DIE4	QE4	B4 – 0	B2 – 0
B5 – 0	B3 – 0	DIE5	QE5	B5 – 0	B3 – 0
B6 – 0	B4 – 0	DIE6	QE6	B6 – 0	B4 – 0
B7 – 0	B5 – 0	DIE7	QE7	B7 – 0	B5 – 0
G0 – 0		DIE8	QE8	G0 – 0	
G1 – 0		DIE9	QE9	G1 – 0	
G2 – 0	G0 – 0	DIE10	QE10	G2 – 0	G0 – 0
G3 – 0	G1 – 0	DIE11	QE11	G3 – 0	G1 – 0
G4 – 0	G2 – 0	DIE12	QE12	G4 – 0	G2 – 0
G5 – 0	G3 – 0	DIE13	QE13	G5 – 0	G3 – 0
G6 – 0	G4 – 0	DIE14	QE14	G6 – 0	G4 – 0
G7 – 0	G5 – 0	DIE15	QE15	G7 – 0	G5 – 0
R0 – 0		DIE16	QE16	R0 – 0	
R1 – 0		DIE17	QE17	R1 – 0	
R2 – 0	R0 – 0	DIE18	QE18	R2 – 0	R0 – 0
R3 – 0	R1 – 0	DIE19	QE19	R3 – 0	R1 – 0
R4 – 0	R2 – 0	DIE20	QE20	R4 – 0	R2 – 0
R5 – 0	R3 – 0	DIE21	QE21	R5 – 0	R3 – 0
R6 – 0	R4 – 0	DIE22	QE22	R6 – 0	R4 – 0
R7 – 0	R5 – 0	DIE23	QE23	R7 – 0	R5 – 0
B0 – 1		DIO0	QO0	B0 – 1	
B1 – 1		DIO1	QO1	B1 – 1	
B2 – 1	B0 – 1	DIO2	QO2	B2 – 1	B0 – 1
B3 – 1	B1 – 1	DIO3	QO3	B3 – 1	B1 – 1
B4 – 1	B2 – 1	DIO4	QO4	B4 – 1	B2 – 1
B5 – 1	B3 – 1	DIO5	QO5	B5 – 1	B3 – 1
B6 – 1	B4 – 1	DIO6	QO6	B6 – 1	B4 – 1
B7 – 1	B5 – 1	DIO7	QO7	B7 – 1	B5 – 1
G0 – 1		DIO8	QO8	G0 – 1	
G1 – 1		DIO9	QO9	G1 – 1	
G2 – 1	G0 – 1	DIO10	QO10	G2 – 1	G0 – 1
G3 – 1	G1 – 1	DIO11	QO11	G3 – 1	G1 – 1
G4 – 1	G2 – 1	DIO12	QO12	G4 – 1	G2 – 1
G5 – 1	G3 – 1	DIO13	QO13	G5 – 1	G3 – 1
G6 – 1	G4 – 1	DIO14	QO14	G6 – 1	G4 – 1
G7 – 1	G5 – 1	DIO15	QO15	G7 – 1	G5 – 1
R0 – 1		DIO16	QO16	R0 – 1	
R1 – 1		DIO17	QO17	R1 – 1	
R2 – 1	R0 – 1	DIO18	QO18	R2 – 1	R0 – 1
R3 – 1	R1 – 1	DIO19	QO19	R3 – 1	R1 – 1
R4 – 1	R2 – 1	DIO20	QO20	R4 – 1	R2 – 1
R5 – 1	R3 – 1	DIO21	QO21	R5 – 1	R3 – 1
R6 – 1	R4 – 1	DIO22	QO22	R6 – 1	R4 – 1
R7 – 1	R5 – 1	DIO23	QO23	R7 – 1	R5 – 1
ShiftClk/2	ShiftClk/2	IDCK	ODCK	Shift CLK	Shift CLK
VSYNC	VSYNC	VSYNC	VSYNC	VSYNC	VSYNC
HSYNC	HSYNC	HSYNC	HSYNC	HSYNC	HSYNC
DE	DE	DE	DE	DE	DE

**Table 13. 24-bit One Pixel per Clock Input with 24-bit Two Pixels per Clock Output TFT Mode**

TFT VGA Output 24-bpp	Tx Input Data		Rx Output Data	TFT Panel Input
	160	164	1151	24-bpp
B0	DIE0	D0	QE0	B0 – 0
B1	DIE1	D1	QE1	B1 – 0
B2	DIE2	D2	QE2	B2 – 0
B3	DIE3	D3	QE3	B3 – 0
B4	DIE4	D4	QE4	B4 – 0
B5	DIE5	D5	QE5	B5 – 0
B6	DIE6	D6	QE6	B6 – 0
B7	DIE7	D7	QE7	B7 – 0
G0	DIE8	D8	QE8	G0 – 0
G1	DIE9	D9	QE9	G1 – 0
G2	DIE10	D10	QE10	G2 – 0
G3	DIE11	D11	QE11	G3 – 0
G4	DIE12	D12	QE12	G4 – 0
G5	DIE13	D13	QE13	G5 – 0
G6	DIE14	D14	QE14	G6 – 0
G7	DIE15	D15	QE15	G7 – 0
R0	DIE16	D16	QE16	R0 – 0
R1	DIE17	D17	QE17	R1 – 0
R2	DIE18	D18	QE18	R2 – 0
R3	DIE19	D19	QE19	R3 – 0
R4	DIE20	D20	QE20	R4 – 0
R5	DIE21	D21	QE21	R5 – 0
R6	DIE22	D22	QE22	R6 – 0
R7	DIE23	D23	QE23	R7 – 0
			QO0	B0 – 1
			QO1	B1 – 1
			QO2	B2 – 1
			QO3	B3 – 1
			QO4	B4 – 1
			QO5	B5 – 1
			QO6	B6 – 1
			QO7	B7 – 1
			QO8	G0 – 1
			QO9	G1 – 1
			QO10	G2 – 1
			QO11	G3 – 1
			QO12	G4 – 1
			QO13	G5 – 1
			QO14	G6 – 1
			QO15	G7 – 1
			QO16	R0 – 1
			QO17	R1 – 1
			QO18	R2 – 1
			QO19	R3 – 1
			QO20	R4 – 1
			QO21	R5 – 1
			QO22	R6 – 1
			QO23	R7 – 1
Shift CLK	IDCK	IDCK	ODCK	Shift CLK/2
VSYNC	VSYNC	VSYNC	VSYNC	VSYNC
HSYNC	HSYNC	HSYNC	HSYNC	HSYNC
DE	DE	DE	DE	DE

**Table 14. 18-bit One Pixel per Clock Input with 18-bit Two Pixels per Clock Output TFT Mode**

TFT VGA Output 18-bpp	Tx Input Data		Tx Output Data		TFT Panel Input 18-bpp
	160	164	1151	141B	
	DIE0	D0	QE0		
	DIE1	D1	QE1		
B0	DIE2	D2	QE2	Q0	B0 – 0
B1	DIE3	D3	QE3	Q1	B1 – 0
B2	DIE4	D4	QE4	Q2	B2 – 0
B3	DIE5	D5	QE5	Q3	B3 – 0
B4	DIE6	D6	QE6	Q4	B4 – 0
B5	DIE7	D7	QE7	Q5	B5 – 0
	DIE8	D8	QE8		
	DIE9	D9	QE9		
G0	DIE10	D10	QE10	Q6	G0 – 0
G1	DIE11	D11	QE11	Q7	G1 – 0
G2	DIE12	D12	QE12	Q8	G2 – 0
G3	DIE13	D13	QE13	Q9	G3 – 0
G4	DIE14	D14	QE14	Q10	G4 – 0
G5	DIE15	D15	QE15	Q11	G5 – 0
	DIE16	D16	QE16		
	DIE17	D17	QE17		
R0	DIE18	D18	QE18	Q12	R0 – 0
R1	DIE19	D19	QE19	Q13	R1 – 0
R2	DIE20	D20	QE20	Q14	R2 – 0
R3	DIE21	D21	QE21	Q15	R3 – 0
R4	DIE22	D22	QE22	Q16	R4 – 0
R5	DIE23	D23	QE23	Q17	R5 – 0
			Q00		
			Q01		
			Q02	Q18	B0 – 1
			Q03	Q19	B1 – 1
			Q04	Q20	B2 – 1
			Q05	Q21	B3 – 1
			Q06	Q22	B4 – 1
			Q07	Q23	B5 – 1
			Q08		
			Q09		
			Q010	Q24	G0 – 1
			Q011	Q25	G1 – 1
			Q012	Q26	G2 – 1
			Q013	Q27	G3 – 1
			Q014	Q28	G4 – 1
			Q015	Q29	G5 – 1
			Q016		
			Q017		
			Q018	Q30	R0 – 1
			Q019	Q31	R1 – 1
			Q020	Q32	R2 – 1
			Q021	Q33	R3 – 1
			Q022	Q34	R4 – 1
			Q023	Q35	R5 – 1
Shift CLK	IDCK	IDCK	ODCK	Shift CLK/2	Shift CLK/2
VSYNC	VSYNC	VSYNC	VSYNC	VSYNC	VSYNC
HSYNC	HSYNC	HSYNC	HSYNC	HSYNC	HSYNC
DE	DE	DE	DE	DE	DE



**Table 15. Two Pixels per Clock Input with One Pixel per Clock Output TFT Mode**

TFT VGA Output		Tx Input Data	Rx Output Data		TFT Panel Input	
24-bpp	18-bpp	160	1151	141B	24-bpp	18-bpp
B0 – 0		DIE0	QE0	Q0	B0	
B1 – 0		DIE1	QE1	Q1	B1	
B2 – 0	B0 – 0	DIE2	QE2	Q2	B2	B0
B3 – 0	B1 – 0	DIE3	QE3	Q3	B3	B1
B4 – 0	B2 – 0	DIE4	QE4	Q4	B4	B2
B5 – 0	B3 – 0	DIE5	QE5	Q5	B5	B3
B6 – 0	B4 – 0	DIE6	QE6	Q6	B6	B4
B7 – 0	B5 – 0	DIE7	QE7	Q7	B7	B5
G0 – 0		DIE8	QE8	Q8	G0	
G1 – 0		DIE9	QE9	Q9	G1	
G2 – 0	G0 – 0	DIE10	QE10	Q10	G2	G0
G3 – 0	G1 – 0	DIE11	QE11	Q11	G3	G1
G4 – 0	G2 – 0	DIE12	QE12	Q12	G4	G2
G5 – 0	G3 – 0	DIE13	QE13	Q13	G5	G3
G6 – 0	G4 – 0	DIE14	QE14	Q14	G6	G4
G7 – 0	G5 – 0	DIE15	QE15	Q15	G7	G5
R0 – 0		DIE16	QE16	Q16	R0	
R1 – 0		DIE17	QE17	Q17	R1	
R2 – 0	R0 – 0	DIE18	QE18	Q18	R2	R0
R3 – 0	R1 – 0	DIE19	QE19	Q19	R3	R1
R4 – 0	R2 – 0	DIE20	QE20	Q20	R4	R2
R5 – 0	R3 – 0	DIE21	QE21	Q21	R5	R3
R6 – 0	R4 – 0	DIE22	QE22	Q22	R6	R4
R7 – 0	R5 – 0	DIE23	QE23	Q23	R7	R5
B0 – 1		DIO0				
B1 – 1		DIO1				
B2 – 1	B0 – 1	DIO2				
B3 – 1	B1 – 1	DIO3				
B4 – 1	B2 – 1	DIO4				
B5 – 1	B3 – 1	DIO5				
B6 – 1	B4 – 1	DIO6				
B7 – 1	B5 – 1	DIO7				
G0 – 1		DIO8				
G1 – 1		DIO9				
G2 – 1	G0 – 1	DIO10				
G3 – 1	G1 – 1	DIO11				
G4 – 1	G2 – 1	DIO12				
G5 – 1	G3 – 1	DIO13				
G6 – 1	G4 – 1	DIO14				
G7 – 1	G5 – 1	DIO15				
R0 – 1		DIO16				
R1 – 1		DIO17				
R2 – 1	R0 – 1	DIO18				
R3 – 1	R1 – 1	DIO19				
R4 – 1	R2 – 1	DIO20				
R5 – 1	R3 – 1	DIO21				
R6 – 1	R4 – 1	DIO22				
R7 – 1	R5 – 1	DIO23				
ShiftClk/2	ShiftClk/2	IDCK	ODCK	ODCK	ShiftClk	ShiftClk
VSYNC	VSYNC	VSYNC	VSYNC	VSYNC	VSYNC	VSYNC
HSYNC	HSYNC	HSYNC	HSYNC	HSYNC	HSYNC	HSYNC
DE	DE	DE	DE	DE	DE	DE

**Table 16. Output Clock Configuration by Typical TFT Panel Application**

PIX	OCK_INV	ODCK (frequency/data latch edge)
0	0	divide by 1 / negative
0	1	divide by 1 / positive
1	0	divide by 2 / negative
1	1	divide by 2 /positive

## Design Recommendations

The following sections describe recommendations for robust board design with this PanelLink receiver. Designers should include provision for these circuits in their design, and adjust the specific passive component values according to the characterization results.

### Differences Between SiI 151B and SiI 1151

The RESERVED pin (pin 99) on the SiI 151B is required to be tied HIGH for normal operation. On the SiI 1151 part, pin 99 is defined so that tying it HIGH maintains pin compatibility with the SiI 151B. In this mode, the SiI 1611 chip meets all operational and timing specifications of the SiI 151B with these exceptions.

- Active mode power consumption is higher on the SiI 1151 part due to the new equalizer circuitry. Refer to Table 1 for actual values.
- $T_{FSC}$  is shorter and more predictable due to improved logic implementation.

### Selecting SiI 1151 (Programmable) Mode

To use the programmable features of the SiI 1151 part:

- Tie pin 99 (the MODE signal) LOW
- Tie pin 7 (the I2C\_MODE# signal) LOW

The chipset registers are now accessible through standard I<sup>2</sup>C signaling up to 400kHz through pins 3 (SDA) and 100 (SCL). Note that these pins must be connected through pullups (2k $\Omega$  recommended) to 3.3V for correct operation. In this mode, several pins change their functionality from the SiI 151B standard as shown in Table 17.

**Table 17. New Pin Functions for SiI 1151 in Programmable Mode**

Pin	MODE tied HIGH	MODE tied LOW
99	Chip is in SiI 151B Compatible Mode	Chip is in SiI 1151 I <sup>2</sup> C Programmable Mode
7	STAG_OUT#	I2C_MODE# HIGH: Not Supported LOW: Chip is in I <sup>2</sup> C Programmable Mode
3	ST	SDA
100	OCK_INV	SCL

### Programmable Mode Reset Recommendations

For programmable mode operation, the SiI 1151 I<sup>2</sup>C logic **must be reset at least once**, at power-up time, for reliable operation.

The reset is triggered whenever PD# (pin 2) transitions from LOW to HIGH after VCC has reached its nominal operating voltage.

If the host controls PD#, this reset occurs automatically whenever the chip is brought from power-down mode to active mode. However, if the host is not controlling PD# and the pin is simply tied to VCC, there will not be sufficient time during initial voltage ramp to reset the logic. Figure 21 illustrates the timing requirement.

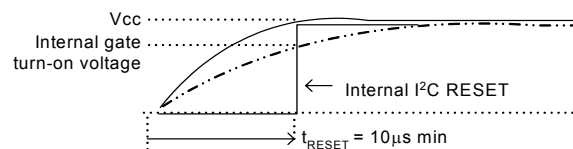

**Figure 21. RESET Generation Delay**

Recommendation: Putting a 1000pF capacitor and a 10kΩ resistor on the PD# pin is sufficient to provide the needed reset delay. If the PD# is already controlled by external logic, that logic should be used to perform the reset function instead.

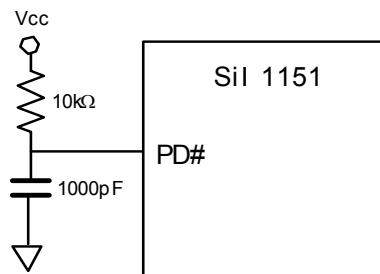

**Figure 22. Recommended RESET Circuit**

For existing circuit designs where these methods are impractical to implement, other solutions may be possible. Contact your Silicon Image technical representative for information.

## Using SiI 1151 in Multiple-Input Applications

Two SiI 1151 parts can be connected with their outputs in parallel to permit video from either of two independent DVI inputs to be recovered and sent to a single image processing device (such as a scaler). As an example of another application, one SiI 1151 part can be used with its outputs in parallel with an ADC to support a dual mode monitor.

These applications may require the following considerations.

- Use the PDO# pin to disable the outputs from the SiI 1151 when it is not in use. The outputs will be tri-stated so that other devices can drive the lines. The chip engages internal pull-down resistors to prevent the outputs from floating, but these are very weak and will not adversely affect other devices driving the bus.
- Use the MODE pin to enable or disable the I<sup>2</sup>C interface from responding. All SiI 1151 parts in the system will use the same I<sup>2</sup>C address, so only one can be enabled for I<sup>2</sup>C access at a time.

The PD# pin can be used in place of both PDO# and MODE. Its assertion will: disable the outputs from the SiI 1151; power down the internal SiI 1151 logic; and disable I<sup>2</sup>C access.

**Note:** Asserting the PD# pin or toggling the MODE pin will reset the state of the registers to their default settings, so upon deassertion all special register settings will need to be rewritten.

## Using SiI 1151 to Replace TI TFP401

The SiI 1151 device pinout is very similar to that of the TI TFP401 receiver. Applications can immediately benefit from improved performance over the TI part, even if the programmability feature of the SiI 1151 device is not used. However, there are some areas that require attention when replacing the TI TFP401 part.

- When the staggered output mode is used, the TI TFP401 part times its DE signal to coincide with the first (ODD) data pixel. The SiI 1151 device times its DE signal to coincide with the first (EVEN) data pixel, one quarter clock period later. The SiI 1151 staggered output timing is provided on page.17.
- If the system has been designed to match the TI TFP401 timing noted above, it is often possible to adapt the SiI 1151 by using the OCK\_INV, ST, and CKST selections to meet system timing requirements. This is possible because the SiI 1151 part has better timing characteristics in most applications.

Contact your Silicon Image representative for additional application-specific suggestions.

## Adjusting Equalizer and Bandwidth

The Sil 1151 provides access to several internal registers that can be set to optimize the connection to a variety of source devices and accommodate a range of cable lengths.

The Sil 1151 provides access to several internal registers that can be set to optimize the connection to a variety of source devices and accommodate a range of cable lengths. Pins must be set in Programmable Mode according to the details shown in Table 17 on page 31. The rules for setting the registers for best operation are flexible; the only goal is to achieve best visual performance on the display. In general these guidelines apply.

- The EQ\_DATA bits correspond to the cable length, with 0000 applying to the longest cables, and 1111 applying to the shortest cables. Cable quality and DVI signal source quality also factor into this setting, so there is no exact correspondence of settings to cable length. With good cable quality and a fully DVI-compliant source, cable lengths in excess of 20m are achievable at SXGA.
- The LBW bits correspond to the clock recovery PLL bandwidth. DVI-compliant transmitters are best accommodated by a setting of 4MHz as dictated by the DVI 1.0 spec. Recovery of data from non DVI-compliant transmitters is often better when the bandwidth is set to a higher value. Refer to Table 19 for setting information.

## Programmable Mode I<sup>2</sup>C Registers

The internal registers are used as shown in Table 18. The I<sup>2</sup>C Device Address for Sil 1151 is 0x76.

- The registers are set to their default values when the PD# pin is driven LOW (as well as when the MODE pin is set to HIGH). If the design does not provide a means of explicitly controlling the PD# signal, an RC circuit should be attached to the PD# pin to ensure that the I2C logic is reset properly at powerup. Refer to “Programmable Mode Reset Recommendations” on Page 31 for information.

**Table 18. Internal I<sup>2</sup>C Registers**

Addr.	Bit 7	Bit 6	Bit 5	Bit 4	Bit 3	Bit 2	Bit 1	Bit 0
0x0	VND_IDL (RO)							
0x1	VND_IDH (RO)							
0x2	DEV_IDL (RO)							
0x3	DEV_IDH (RO)							
0x4	DEV_REV (RO)							
0x5-0x8	RSVD							
0x9	RSVD				EQ_DATA[3:0]			
0xA	RSVD	STAG_OUT#	OCK_INV	CKST	ST	RSVD	RSVD	
0xB	RSVD			ZONEO (RO)	RSVD	LBW[1:0]		
0xC-0xF	RSVD							

### Notes

1. All values are Bit 7 [msb] and Bit 0 [lsb].
2. RW (or unmarked) indicates a read/write field. RO indicates a read-only field.
3. RSVD registers must not be accessed. RSVD bits or fields should be written as 0 when writing other bits in the register.

**Table 19: I<sup>2</sup>C Register Field Definitions**

Register Name	Access	Default	Description
VND_IDL	RO	0x01	Vendor ID Low Byte
VND_IDH	RO	0x00	Vendor ID High Byte
DEV_IDL	RO	0x00	Device ID Low Byte
DEV_IDH	RO	0x00	Device ID High Byte
DEV_REV	RO	0x00	Device Revision Byte
EQ_DATA	RW	0xD	Equalization Setting. All settings are valid. For non DVI-compliant transmitters, stronger equalization may be necessary even for shorter cables. 0000 = Most equalization (long cables) : 1101 = Moderate equalization (default) : 1111 = Least equalization (short cables)
ST	RW	1	Data and Sync Output Drive Strength 0 = Low-Drive 1 = High-Drive (default)
CKST	RW	0	Clock and DE Output Drive Strength 0 = High-Drive (strength is 2X that of Data and Sync -default) 1 = Low-Drive (strength is equal to that of Data and Sync)
OCLK_INV	RW	0	ODCK Polarity 0 = Normal polarity (default) 1 = Inverted polarity
STAG_OUT #	RW	1	Staggered Data Bus Outputs 0 = Staggered 1 = Non-staggered (default)
LBW	RW	00	Bandwidth of the PLL: 00 = 4MHz (default) 01 = 3MHz 10 = 6MHz (often the best setting for non DVI-compliant transmitters) 11 = 5MHz
ZONEO	RO	0	Zone Output – indicates current operating zone 0 = Operating in zone optimized for lower frequencies 1 = Operating in zone optimized for higher frequencies

## Voltage Ripple Regulation

The power supply to VCC pins is very important to the proper operation of the receiver chips. Two examples of regulators are shown in Figure 23 and Figure 24.

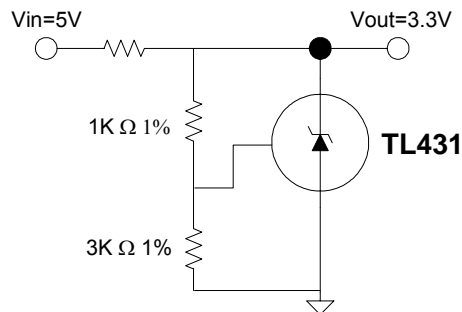
**Figure 23. Voltage Regulation using TL431**

Decoupling and bypass capacitors are also involved with power supply connections, as described in detail in Figure 26.

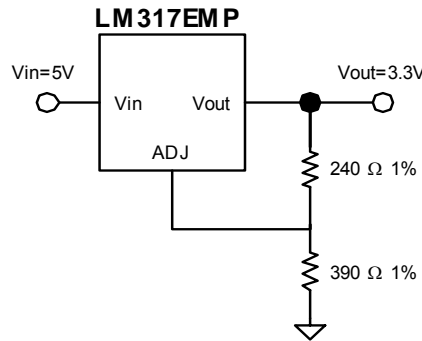

**Figure 24. Voltage Regulation using LM317**

For the purposes of efficient power supply design, the relative power consumption of each of the power planes can be estimated as follows as a percentage of total chip power consumption.

- AVCC: 30-35%
- DVCC: 30-40%
- PVCC: 10-15%
- OVCC: 20-40%

The power consumed by the OVCC power plane shows greater range than the others because of the variety of loading possibilities. PVCC is the power plane that is most sensitive to excessive noise, but noise on this plane can be controlled relatively easily due to the limited power consumed.

### Decoupling Capacitors

Designers should include decoupling and bypass capacitors at each power pin in the layout. These are shown schematically in Figure 26. Place these components as closely as possible to the Panellink device pins, and avoid routing through vias if possible, as shown in Figure 25, which is representative of the various types of power pins on the receiver.

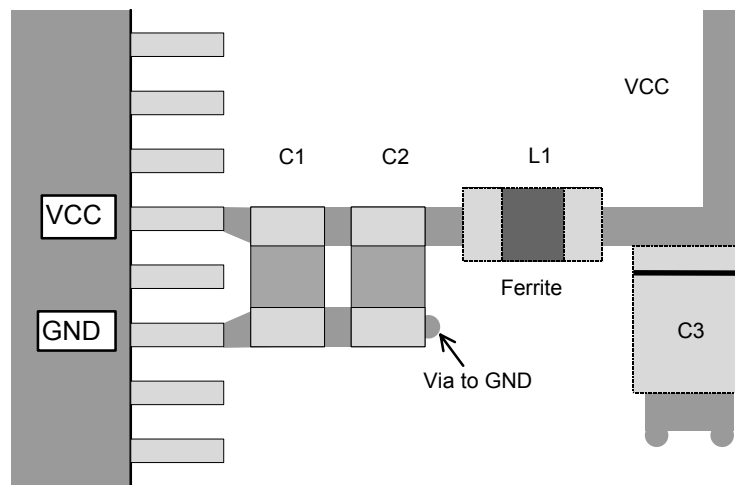

**Figure 25. Decoupling and Bypass Capacitor Placement**

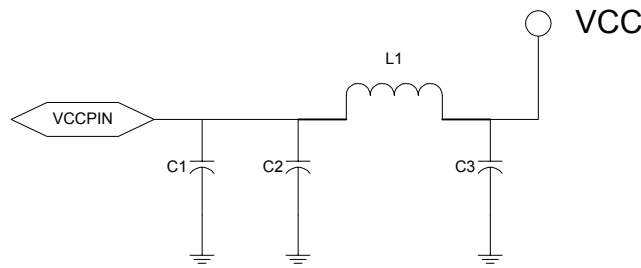

**Figure 26. Decoupling and Bypass Schematic**

The values shown in Table 20 are recommendations for noise suppression in the 1-2MHz range that should be adjusted according to the noise characteristics of the specific board-level design. Pins in one group (such as OVCC) may share L1 and C3, each pin having C1 and C2 placed as close to the pin as possible. This filter circuit should be placed on planes where power supply ripple could exceed the VCC noise specification.

**Table 20. Recommended Components for 1-2MHz Noise Suppression**

C1	C2	C3	L1
100 – 300 pF	0.1 $\mu$ F	10 $\mu$ F	Ferrite, 200+ $\Omega$ @ 100MHz

The PLL circuit that is powered from PVCC is more sensitive to noise in the 100-200kHz range. If the power supply is prone to generation of noise in this range in excess of the  $PV_{CCN}$  specification, the component values shown in Table 21 should be used on the PVCC plane.

**Table 21. Recommended Components for 100-200kHz Noise Suppression on PVCC**

C1	C2	C3	L1
not used	6.8 $\mu$ F	10 $\mu$ F	10 $\mu$ H inductor

### Series Damping Resistors on Outputs

Small (~22ohms) series resistors are effective in lowering the data-related emissions and reducing reflections. Series resistors should be placed close to the output pins on the receiver chip, as shown in Figure 27.

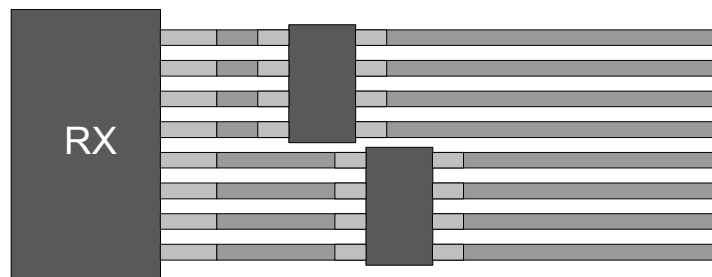

**Figure 27. Receiver Output Series Damping Resistors**



## Receiver Layout

The receiver chip should be placed as close as possible to the input connector that carries the TMDS signals. For a system using the industry-standard DVI connector (see <http://www.ddwg.org>), the differential lines should be routed as directly as possible from connector to receiver. Differential pair length is not critical but ideally should be less than 10cm.

PanelLink devices are tolerant of skews between differential pairs, so spiral skew compensation for path length differences is not required. However, each conductor of the differential pair should be routed together with equal trace lengths. Vias should be avoided, but if used they should be placed on both signal lines of the differential pair in a way that gives both lines equivalent reflection characteristics. Figure 28 illustrates acceptable routing practices for TMDS signals from a DVI connector, while Figure 29 shows an example of actual trace routing.

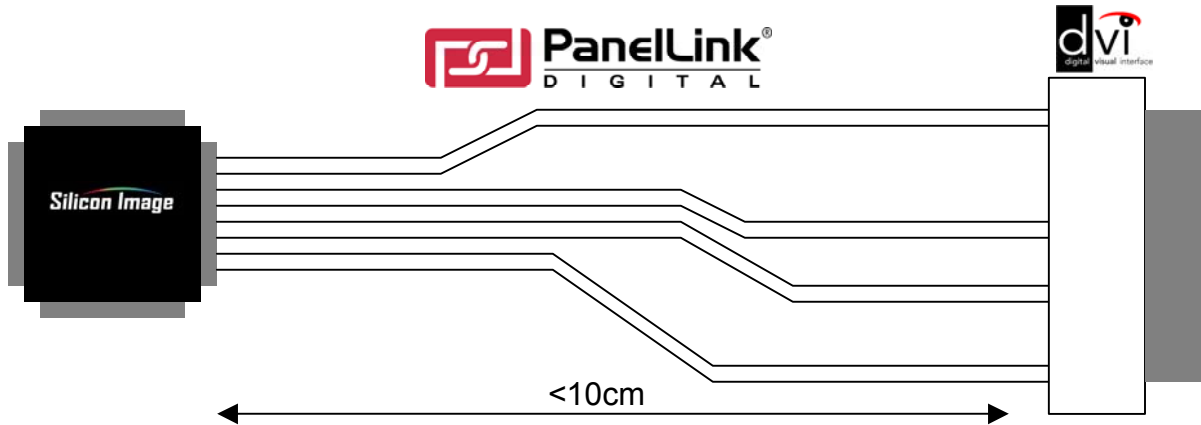

Figure 28. General Signal Routing Recommendations

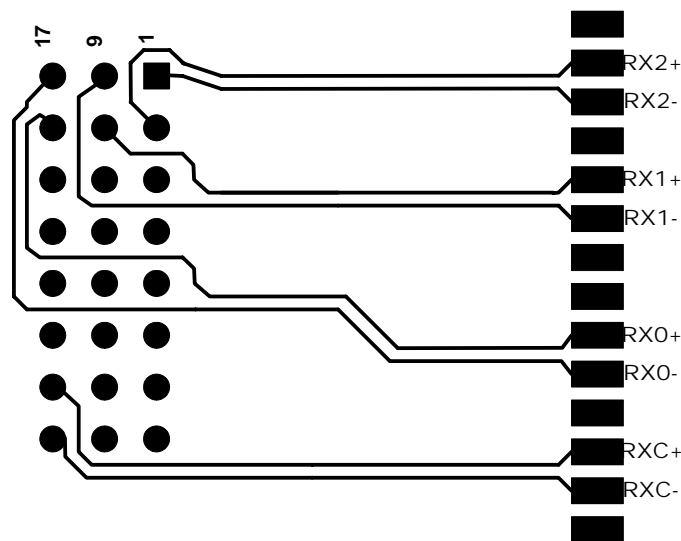

Figure 29. Signal Trace Routing Example

## PCB Ground Planes

All ground pins on the device should be connected to the same, contiguous ground plane in the PCB. This helps to avoid ground loops and inductances from one ground plane segment to another. Such low-inductance ground paths are critical for return currents, which affect EMI performance. The entire ground plane surrounding the PanelLink receiver should be one piece, and include the ground vias for the DVI connector.

As defined in the DVI 1.0 Specification, the impedance of the traces between the connector and the receiver should be  $100\Omega$  differentially, and close to  $50\Omega$  single-ended. The  $100\Omega$  requirement is to best match the differential impedance of the cable and connectors, to prevent reflections. The common mode currents are very small on the TMDS interface, so differential impedance is more important than single-ended.

## Staggered Outputs and Two Pixels per Clock

PanelLink receivers offer two features that can minimize the switching effects of the high-speed output data bus: two pixels per clock mode and staggered outputs.

The receiver can output one or two pixels in each output clock cycle. By widening the bus to two pixels per clock whenever possible, the clock speed is halved and the switching period of the data signals themselves is twice as long as in one pixel per clock mode. Typically, SXGA-resolution and above LCD panels expect to be connected with a 36-bit or 48-bit bus, two pixels per clock. Most XGA-resolution and below LCD panels use an 18- to 24-bit one pixel per clock interface.

When in two pixel per clock mode, the STAG\_OUT# pin on receivers provides an additional means of reducing simultaneous switching activity. When enabled (STAG\_OUT# = Low), only half of the output data pins switch together. The other half are switched one quarter clock cycle later. Note that both pixel buses use the same clock. Therefore, the staggered bus will have one quarter clock cycle less setup time to the clock, and one quarter clock cycle more hold time. Board designers driving into another clocked chip should take this into account in their timing analysis.

Silicon Image recommends the use of STAG\_OUT# and the two pixels per clock mode whenever possible.

## Adjusting Output Timings for Loading

If not using the I<sup>2</sup>C drive strength programmability, the SiI 1151 can be made to accommodate different output loads by adding external capacitance. Refer to Figure 3 for an illustration of the loading requirements on DE and ODCK.

## Packaging

### Dimensions and Marking

100-pin LQFP Package Dimensions and Marking Specification

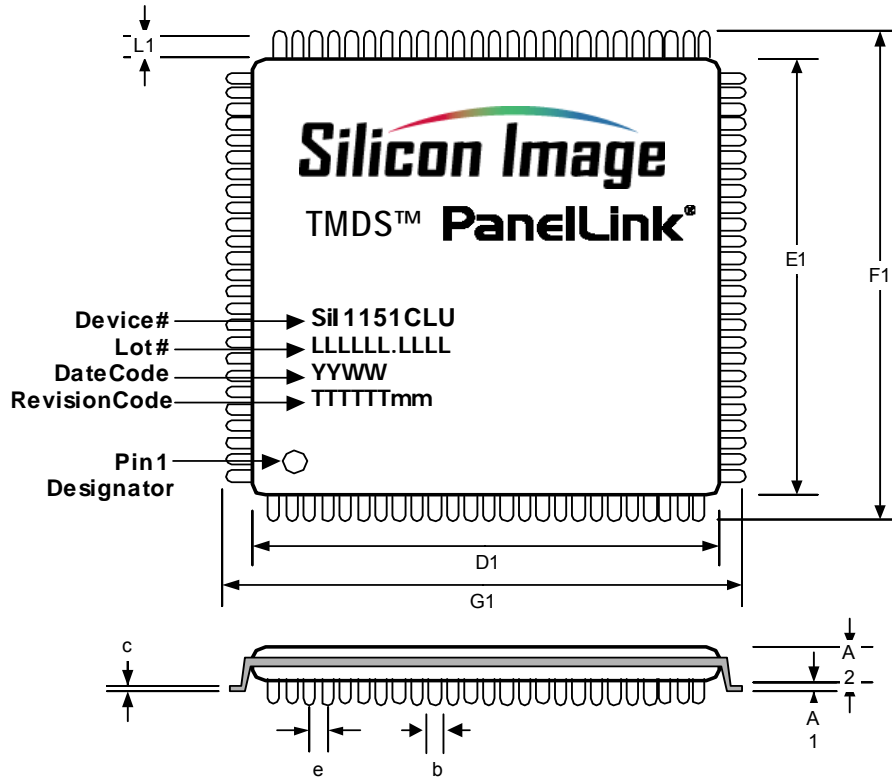

#### JEDEC Package Code MS026-AED

		typ	max
A	Thickness		1.60
A1	Stand-off	0.10	0.15
A2	Body Thickness	1.40	1.45
D1	Body Size	14.00	
E1	Body Size	14.00	
F1	Footprint	16.00	
G1	Footprint	16.00	
L1	Lead Length	1.00	
b	Lead Width	0.20	
c	Lead Thickness		0.20
e	Lead Pitch	0.50	

Dimensions in millimeters.  
Overall thickness  $A = A1 + A2$ .

#### Universal Package: Sil1151CLU

Legend	Description
LLLLLL.LLLL	Lot Number
YY	Year of Mfr
WW	Week of Mfr
TTTTTmm	Trace Code
mm	Maturity Code 0: engineering samples =1: pre-production >1: production

Figure 30. Package Diagram

Note: The marking specification for the Sil-1151 was updated January 1, 2004. Please refer to Product Change Notice (Sil-PC-0044) "Marking Standard for 1161 and 1151", for information on Sil-1151 parts manufactured prior to December 31, 2003. Sil-PC-0044 covers parts with Date Codes of 0301 through 0352.

### Ordering Information

Part Number of Universal package for both Standard and Pb-Free applications: Sil1151CLU

Note: All Silicon Image Pb-Free (Universal) packages are also rated for the standard Sn/Pb reflow process. Please refer to the document (Sil-CM-0058) "Reflow Temperature Profile of Standard Leaded and Lead-free or Green Packages", for more details.

© 2004, 2005 Silicon Image, Inc.



**Silicon Image, Inc.**  
1060 E. Arques Avenue  
Sunnyvale, CA 94085  
USA

Tel:(408) 616-4000  
Fax:(408) 830-9530  
E-mail:[salesupport@siimage.com](mailto:salesupport@siimage.com)  
Web:[www.siliconimage.com](http://www.siliconimage.com)